

SURVEY PLAT

TO ALL PARTIES INTERESTED IN THE PREMISES SURVEYED:
THIS IS TO CERTIFY THAT I HAVE THIS DATE MADE A CAREFUL AND ACCURATE SURVEY ON THE GROUND OF
PROPERTY LOCATED AT 3304 GLENWOOD DRIVE, IN THE CITY OF WYLIE, TEXAS, HEREIN DESCRIBED AS FOLLOWS:

LOT 4, BLOCK K OF CREEKSIDE ESTATES PHASE 2, AN ADDITION TO THE CITY OF WYLIE,
COLLIN COUNTY, TEXAS, ACCORDING TO THE PLAT THEREOF RECORDED IN VOLUME P,
PAGE 211 MAP RECORDS, COLLIN COUNTY, TEXAS.

EDWARD RAY DONIHOO
VOLUME 549, PAGE 461, DRCCT.



NORTH
SCALE 1"=20'

**ATTACHED PATIO
COVER**

**SETBACKS
REAR - 16'
LEFT - 33'
RIGHT - 22'**

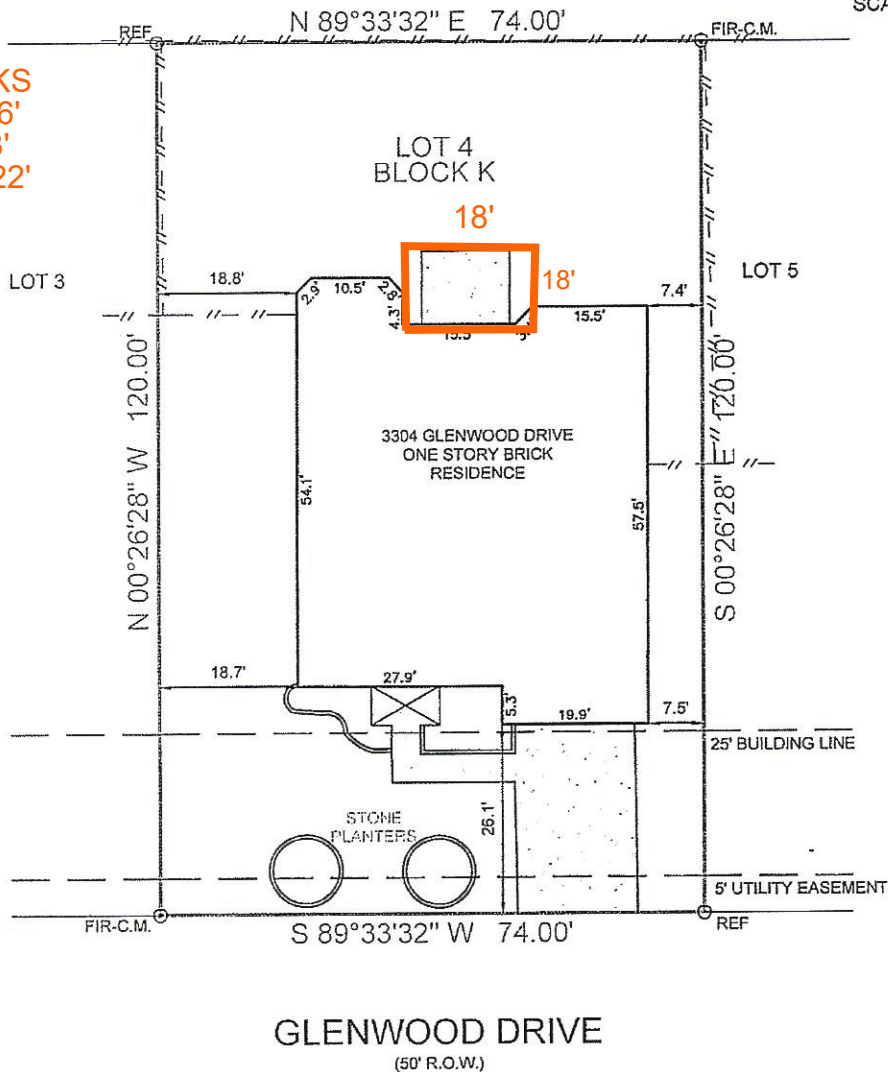

LEGEND: --- WOOD FENCE --- CHAIN LINK FENCE --- GENERAL FENCE	FIP FOUND IRON PIPE FIR FOUND IRON ROD C.M. CONTROL MONUMENT B/L BUILDING SETBACK LINE	NOTES: THIS LOT IS SUBJECT TO VOLUME 5194, PAGE 455, VOLUME 5198, PAGE 1199, AND VOLUME 5298, PAGE 3563, DRCCT. VOLUME 507, PAGE 221, AND VOLUME 4825, PAGE 2742, DRCCT. DO NOT AFFECT THIS LOT.
---	---	--

TO LSI TITLE AGENCY, INC.
THE PLAT HEREON IS A TRUE, CORRECT AND ACCURATE PRESENTATION OF THE PROPERTY AS
DETERMINED BY SURVEY, THE LINE AND DIMENSIONS OF SAID PROPERTY BEING, AS INDICATED
BY THE PLAT; THE SIZE, LOCATION AND TYPE OF BUILDING, AND IMPROVEMENTS, ARE SHOWN, ALL
IMPROVEMENTS BEING WITHIN THE BOUNDARIES OF THE PROPERTY SETBACK FROM THE
PROPERTY LINES THE DISTANCES INDICATED, AS SHOWN ON SAID PLAT. THERE ARE NO VISIBLE
PROTRUSIONS EXCEPT AS SHOWN.



PROPOSED BORROWER
MELISSA FLORES

PROPOSED INSURED
WELLS FARGO HOME MORTGAGE

DATE 08.06.2008
GF. NO. 08-0010757
JOB NO. 280882V

THIS PROPERTY IS LOCATED IN AN AREA WITHIN ZONE X,
OUTSIDE THE 100-YEAR FLOOD PLAIN ACCORDING TO THE
FLOOD INSURANCE RATE MAP FOR THE CITY OF WYLIE.

© COPYRIGHT 2008

MARANOT
Xavier Chapa Engineering/Surveying
A MARANOT SUBSIDIARY
P.O. Box 153311 Irving, Texas 75015

6913 K Ave #307
Plano, TX 75074

Phone: 972-881-4244
Email: office@texasbackyardliving.com

CONTACT	
Name:	JASON NYE
Phone:	8064456007
Email:	

CUSTOMER	
Name:	Brent Garen
Phone:	
Address:	3304 West Glenwood Dri

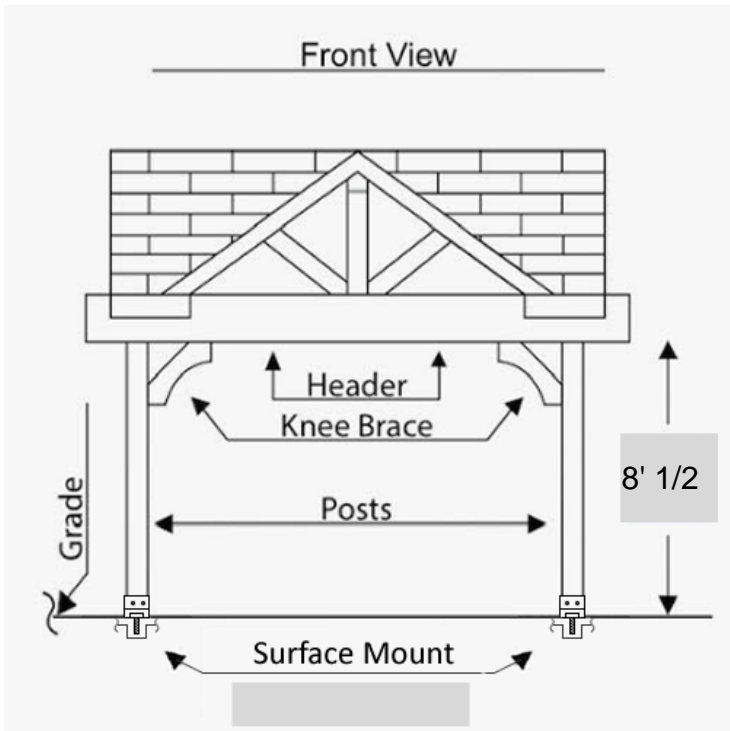
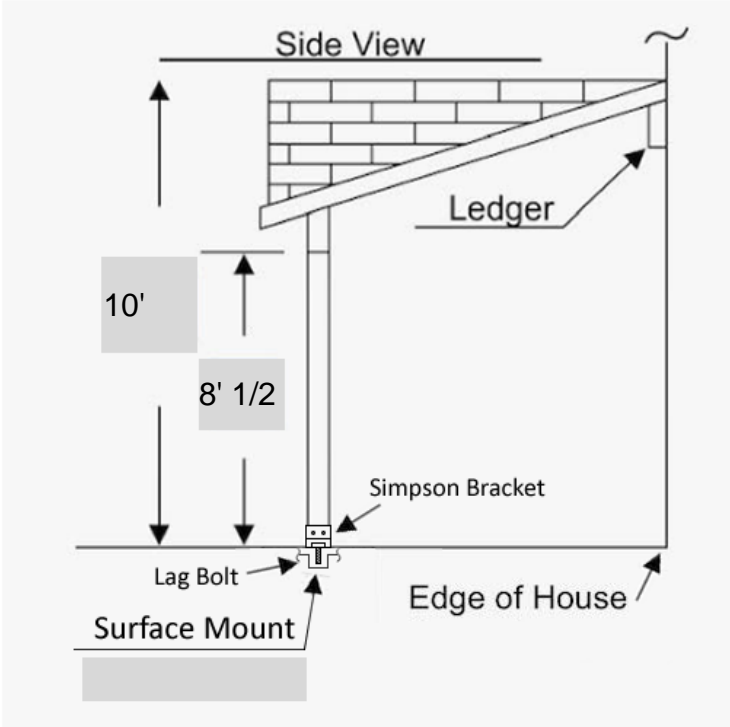
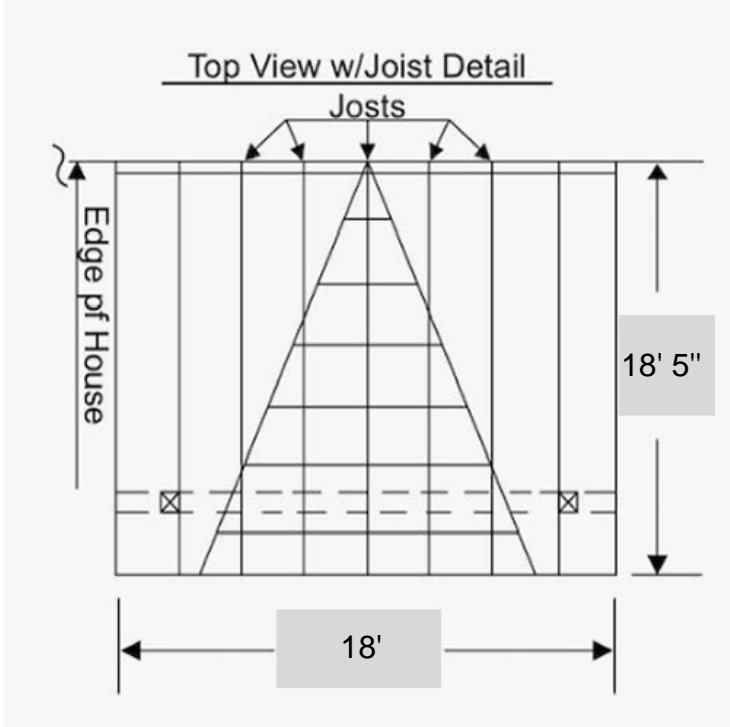

Posts	8"X8"
Header	4"X12"
Joists	2"X8"
Joist Space	24"
Knee Brace	4"X6"
Shingles	MATCH HOUSE
Sunburst	CEDAR
Lag Screws	TIMBERLOCK 10"
Stain	OIL MEDIUM BROWN
Notes	
ATTACHED TO ROOF USING LEDGE BOARD AND 10" BOLTS INTO HOUSE RAFTERS	