

VICINITY MAP
NOT TO SCALE

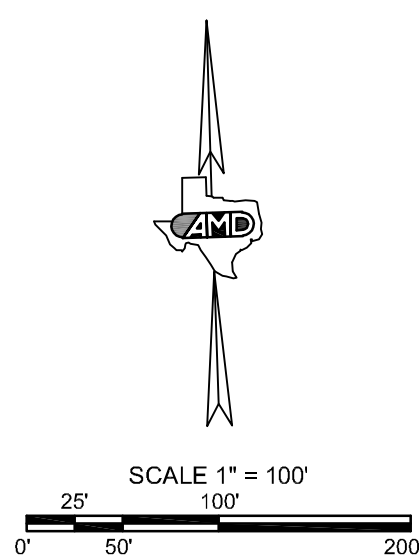

THE OVERLOOK, LOTS 342-A THROUGH 389-A,

A REPLAT OF LOTS 342 THROUGH 390
OF THE OVERLOOK, LOTS 179 THROUGH 390,

AN ADDITION TO THE CITY OF WOLFFORTH, LUBBOCK COUNTY, TEXAS

(ORIGINAL PLAT PREVIOUSLY RECORDED IN COUNTY CLERK'S PLAT AND DEDICATION NUMBER 2023033089 OF
THE OFFICIAL PUBLIC RECORDS OF LUBBOCK COUNTY, TEXAS)

PLAT CURVE TABLE					
CURVE	RADIUS	ARC LENGTH	DELTA ANGLE	CHORD LENGTH	CHORD BEARING
C1	40.00'	26.06'	37°19'40"	25.60'	S. 20°30'49" W.
C2	43.00'	191.12'	254°39'19"	68.39'	S. 88°09'00" E.
C3	40.00'	26.06'	37°19'40"	25.60'	N. 16°48'50" W.

LOT CURVE TABLE					
CURVE	RADIUS	ARC LENGTH	DELTA ANGLE	CHORD LENGTH	CHORD BEARING
C4	40.00'	21.31'	30°31'42"	21.06'	N. 13°24'51" W.
C5	40.00'	4.75'	6°47'58"	4.74'	N. 32°04'41" W.
C6	43.00'	43.33'	57°43'45"	41.52'	N. 06°36'47" W.
C7	43.00'	52.23'	69°35'54"	49.08'	N. 57°03'02" E.
C8	43.00'	52.23'	69°35'59"	49.08'	S. 53°21'01" E.
C9	43.00'	43.32'	57°43'41"	41.51'	S. 10°18'49" W.
C10	40.00'	4.75'	6°48'02"	4.74'	S. 35°46'38" W.
C11	40.00'	21.31'	30°31'37"	21.06'	S. 17°06'48" W.
C12	40.00'	21.30'	30°30'59"	21.05'	S. 13°24'30" E.
C13	40.00'	4.76'	6°48'41"	4.75'	N. 32°04'20" W.
C14	43.00'	43.32'	57°43'09"	41.51'	N. 06°37'06" W.
C15	43.00'	52.24'	69°36'31"	49.09'	N. 57°02'44" E.
C16	43.00'	52.24'	69°36'35"	49.09'	S. 53°20'43" E.
C17	43.00'	43.32'	57°43'04"	41.51'	S. 10°19'07" W.
C18	40.00'	4.76'	6°48'45"	4.75'	S. 35°46'17" W.
C19	40.00'	21.30'	30°30'55"	21.05'	S. 17°06'27" W.

PLAT LINE TABLE		
LINE	BEARING	DISTANCE
L1	S. 43°08'59" E.	14.14'
L2	S. 46°51'00" W.	21.21'
L3	N. 43°09'00" W.	21.21'
L4	N. 01°51'00" E.	203.01'
L5	N. 46°51'01" E.	14.14'
L6	S. 43°08'59" E.	21.21'
L7	S. 01°51'00" W.	99.68'
L8	N. 01°51'00" E.	99.68'
L9	N. 46°51'01" E.	21.21'
L10	S. 01°51'00" W.	203.01'
L11	N. 43°09'00" W.	14.14'
L12	S. 46°51'00" W.	14.14'
L13	N. 01°51'00" E.	203.02'
L14	S. 01°51'00" W.	99.69'
L15	N. 01°51'00" E.	99.69'
L16	S. 01°51'00" W.	203.02'

LOT LINE TABLE		
LINE	BEARING	DISTANCE
L17	N. 01°51'00" E.	20.00'

NOTE

ALL TPE'S WERE PREVIOUSLY DEDICATED WITH THE ORIGINAL PLAT RECORDED IN COUNTY CLERK'S PLAT AND DEDICATION NUMBER 2023033089:

- TPE 1 = SOUTH LINE OF TPE 1 IS 19.00' NORTH OF THE SOUTH LINE OF LOT 351-A
- TPE 2 = NORTH LINE OF TPE 2 IS 12.00' SOUTH OF THE NORTH LINE OF LOT 353-A
- TPE 3 = SOUTH LINE OF TPE 3 IS 10.00' NORTH OF THE SOUTH LINE OF LOT 365-A
- TPE 4 = NORTH LINE OF TPE 4 IS ON THE NORTH LINE OF LOT 367-A
- TPE 5 = SOUTH LINE OF TPE 5 IS 19.00' NORTH OF THE SOUTH LINE OF LOT 379-A
- TPE 6 = NORTH LINE OF TPE 6 IS 12.00' SOUTH OF THE NORTH LINE OF LOT 381-A

NOTES:

- HEAVY LINES INDICATE PLAT LIMITS.
- ALL STREETS, ALLEYS, AND EASEMENTS WITHIN PLAT LIMITS ARE HEREIN DEDICATED, UNLESS NOTED OTHERWISE.
- NO BUILDING PERMIT SHALL BE ISSUED ON ANY SURVEY CERTIFICATE THAT IS NOT IN ACCORDANCE WITH THIS FINAL PLAT.
- ANY RELOCATION OR REVISION OF EXISTING FACILITIES SHALL BE THE SUBDIVIDER'S EXPENSE. COMPENSATION SHALL BE MADE PRIOR TO RECORDING OF THIS FINAL PLAT.
- ALL EXISTING OR PROPOSED UTILITY SERVICES TO AND ON TRACTS INDICATED BY THIS PLAT SHALL BE CONTAINED IN THE PUBLIC RIGHT-OF-WAY AND PUBLIC OR PRIVATE UTILITY EASEMENTS. UTILITY SERVICE INSTALLATION REQUESTED AT A FUTURE DATE AND NOT WITHIN AN EASEMENT INDICATED BY THIS PLAT, SHALL BE WITHIN A PROPER UTILITY EASEMENT GRANTED BY THE OWNER OF SAID PROPERTY BY SEPARATE RECORDED INSTRUMENT PRIOR TO THE PROVISION OF SUCH SERVICE. SUCH EASEMENTS SHALL BE AT THE EXPENSE OF THE ENTITY REQUESTING SUCH INSTALLATION.
- ALL EASEMENTS HEREIN GRANTED SHALL ENTITLE THE CITY OR THE UTILITY COMPANY USING SUCH EASEMENTS TO THE RIGHT TO REMOVE, REPAIR OR REPLACE ANY LINES, PIPES, CONDUITS, OR POLES WITHIN SUCH EASEMENTS AS MAY BE DETERMINED BY THE CITY OR UTILITY COMPANY WITHOUT THE CITY OR UTILITY COMPANY BEING RESPONSIBLE OR LIABLE FOR THE REPLACEMENT OF IMPROVEMENTS, PAVING OR SURFACING OF THE EASEMENT NECESSITATED BY SUCH REPAIR, REMOVAL, OR REPLACEMENT. EASEMENTS DESIGNATED OR INTENDED FOR VEHICULAR PASSAGE (UTILITY AND EMERGENCY) OR PEDESTRIAN ACCESS SHALL NOT BE FENCED OR OTHERWISE OBSTRUCTED.
- ANY EASEMENTS OR RIGHTS-OF-WAY SHOWN AS "TO BE DEDICATED BY SEPARATE INSTRUMENT" ARE SHOWN ON THE PLAT FOR INFORMATION PURPOSES ONLY. THIS PLAT DOES NOT DEDICATE SAID EASEMENTS.
- IN ORDER TO PREVENT DAMAGE TO PUBLIC AND PRIVATE UTILITIES AND TO MINIMIZE AND OR ELIMINATE INTERRUPTION OF UTILITY SERVICES, THE CITY OF WOLFFORTH REQUESTS THAT NO UTILITY RISERS, METER BASES, PEDESTALS, ETC., PUBLIC OR PRIVATE, BE PLACED IN THE CHAMFERED CORNERS OF ALLEY WAYS.

- CCFN = COUNTY CLERK'S FILE NUMBER
- P&D = COUNTY CLERK'S PLAT AND DEDICATION NUMBER
- R-O-W = RIGHT-OF-WAY
- TPE = 4' X 6' (MINIMUM) TRANSFORMER PAD EASEMENT (SPEC), INDICATED BY SYMBOL ☒
- USE = UNDERGROUND STREETLIGHT CABLE EASEMENT
- SPEC = SOUTH PLAINS ELECTRIC COOPERATIVE

ALL CORNERS ARE MONUMENTED WITH 1/2" IRON RODS WITH CAPS MARKED "AMD ENGINEERING", EITHER FOUND OR SET, UNLESS OTHERWISE NOTED.
BEARINGS AND COORDINATES SHOWN HEREON ARE RELATIVE TO THE TEXAS COORDINATE SYSTEM OF 1983 (2011), TEXAS NORTH CENTRAL ZONE, AS DETERMINED BY A POINT OF ORIGIN LOCATED AT NORTHING: 7,245,217.570 AND EASTING: 899,519.772. THE CONVERGENCE ANGLE TO TRUE NORTH IS (-)01° 54' 46.24" AND THE COMBINED SCALE FACTOR IS 0.99974921.
DISTANCES SHOWN HEREON ARE AT SURFACE, IN U.S. SURVEY FEET.
THESE PLAT LIMITS CONTAIN A TOTAL OF 4.693 ACRES OF LAND IN AGGREGATE OF FIVE PARCELS. DESCRIPTION OF THESE PLAT LIMITS ARE ON A SEPARATE DOCUMENT, OF SAME DATE HEREWITH.

KNOW ALL MEN BY THESE PRESENTS:
THAT I, LONDON MERRITT, REGISTERED PROFESSIONAL LAND SURVEYOR, DO HEREBY CERTIFY THAT I PREPARED THIS PLAT FROM AN ACCURATE AND CORRECT SURVEY OF THE LAND AND THAT THE CORNER MONUMENTS AND/OR OTHER CONTROL SHOWN THEREON WERE PROPERLY PLACED UNDER MY PERSONAL SUPERVISION, IN ACCORDANCE WITH THE SUBDIVISION REGULATIONS OF THE CITY OF WOLFFORTH, TEXAS.

REGISTERED PROFESSIONAL LAND SURVEYOR # 6466
LUBBOCK, TEXAS
SURVEYED: AUGUST 8, 2023

**PLAT FOR REVIEW,
DO NOT RECORD
05/20/2024 @**

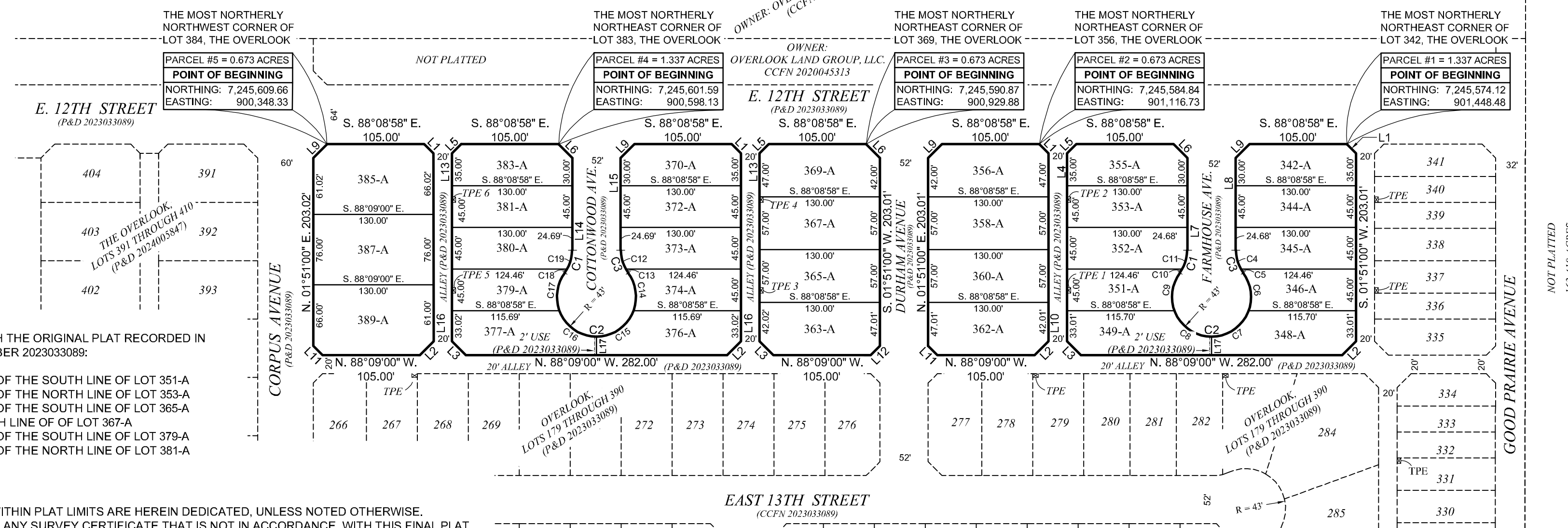

APPROVED THIS _____ DAY OF _____, 20____,
BY THE CITY COUNCIL OF THE CITY OF WOLFFORTH, TEXAS.

APPROVED:

MAYOR

ATTEST:

CITY SECRETARY

SECTION 24, BLOCK AK, HE & WT RR. Co., ABSTRACT No. 885



CIVIL ENGINEERING
LAND SURVEYING

AMD Engineering, LLC
6515 68th Street, Suite 300
Lubbock, TX 79424

Phone: 806-771-5976
Fax: 806-771-7625
TBPELS Reg. # 10178500

Accuracy - Efficiency - Integrity

PROPERTY OWNER: OVERLOOK LAND DEVELOPMENT GROUP, LLC.
ADDRESS: P.O. BOX 53417, LUBBOCK, TEXAS 79453
PHONE: 806-781-7928
JOB NUMBER: 240233

©2024 ALL RIGHTS RESERVED