



PLANNING COMMISSION

WEDNESDAY, DECEMBER 13, 2023

PUBLIC HEARING

2. Wastewater Treatment Plant Master Plan (Nacrelli) (30 minutes)

**PLANNING COMMISSION
RESOLUTION NO. LP22-0001**

**A RESOLUTION OF THE CITY OF WILSONVILLE PLANNING COMMISSION
RECOMMENDING THE WILSONVILLE CITY COUNCIL ADOPT AN UPDATE TO THE
WASTEWATER TREATMENT PLANT MASTER PLAN.**

WHEREAS, the City of Wilsonville Wastewater Treatment Plant was last upgraded in 2014, pursuant to Resolution No. 2131; and

WHEREAS, the Capital Improvement Program identified the completion of a Wastewater Treatment Plant Master Plan (“Plan”) for FY 2023-24; and

WHEREAS, the Plan provides a detailed framework for expanding treatment process capacity to accommodate future development, comply with environmental regulations, and replace aging assets; and

WHEREAS, the concepts and information contained in the proposed update to the Wastewater Treatment Plant Master Plan were presented at a virtual public meeting on September 28, 2022; and

WHEREAS, the Planning Commission of the City has the authority to review and make recommendations to the City Council regarding the Capital Improvement Program pursuant to Wilsonville Code Sections 2.322 and 4.032; and

WHEREAS, the Planning Commission conducted work sessions on the draft Plan at their regular meetings of July 13 and September 14, 2022 and October 11, 2023; and

WHEREAS, the Planning Commission, after Public Hearing Notices were mailed to property owners within the City limits and a list of interested citizens and agencies, and were posted in three locations throughout the City and on the City website, held a Public Hearing on December 13, 2023, to review the Plan and to gather additional testimony and evidence regarding the proposed Master Plan update in accordance with the public hearing and notice procedures that are set forth in Sections 4.008, 4.010, 4.011 and 4.012 of the Wilsonville Code (WC); and

WHEREAS, the Planning Commission has afforded all interested parties an opportunity to be heard on this subject and has entered all available evidence and testimony into the public record of their proceeding; and

WHEREAS, the Planning Commission has duly considered the subject, including the staff recommendations and all the exhibits and testimony introduced and offered by all interested parties.

NOW, THEREFORE, THE CITY OF WILSONVILLE PLANNING COMMISSION RESOLVES AS FOLLOWS:

Section 1. The Wilsonville Planning Commission does hereby adopt the Planning Staff Report (attached hereto as Exhibit A) and Attachments, as presented at the December 13, 2023, public hearing, including the conclusionary findings and recommendations contained therein.

Section 2. The Planning Commission does hereby recommend that the Wilsonville City Council adopt the proposed Wastewater Treatment Plant Master Plan, attached as Exhibit B.

Section 3. Effective Date. This Resolution is effective upon adoption.

ADOPTED by the Wilsonville Planning Commission at a regular meeting thereof this 13th day of December, 2023, and filed with the Planning Administrative Assistant on this date.

Wilsonville Planning Commission

ATTEST:

Mandi Simmons, Administrative Assistant III

SUMMARY OF VOTES:

Ronald Heberlein, Chair _____
Jennifer Willard, Vice-Chair _____
Nicole Hendrix _____
Andrew Karr _____
Kamran Mesbah _____
Kathryn Neil _____

EXHIBITS:

A. Staff Report and Attachments



**PLANNING COMMISSION
STAFF REPORT**

Meeting Date: December 13, 2023		Subject: Wastewater Treatment Plant Master Plan	
		Staff Member: Mike Nacrelli, Senior Civil Engineer	
		Department: Community Development	
Action Required		Advisory Board/Commission Recommendation	
<input checked="" type="checkbox"/> Motion <input checked="" type="checkbox"/> Public Hearing Date: 12/13/2023 <input type="checkbox"/> Ordinance 1 st Reading Date: <input type="checkbox"/> Ordinance 2 nd Reading Date: <input checked="" type="checkbox"/> Resolution <input type="checkbox"/> Information or Direction <input type="checkbox"/> Information Only <input type="checkbox"/> Council Direction <input type="checkbox"/> Consent Agenda		<input type="checkbox"/> Approval <input type="checkbox"/> Denial <input type="checkbox"/> None Forwarded <input checked="" type="checkbox"/> Not Applicable	
		Comments: N/A	
Staff Recommendation: A motion to approve a recommendation to the City Council adopting the Wastewater Treatment Plant Master Plan			
Recommended Language for Motion: I move to approve Resolution LP22-0001 recommending approval of the Wastewater Treatment Plant Master Plan			
Project / Issue Relates To:			
<input checked="" type="checkbox"/> Council Goals/Priorities: Strategy 1. Develop an Infrastructure resilience plan and reprioritize / fund recommended projects.	<input type="checkbox"/> Adopted Master Plan(s):	<input type="checkbox"/> Not Applicable	

ISSUE BEFORE PLANNING COMMISSION:

The City of Wilsonville is completing a Wastewater Treatment Plant Master Plan to accommodate anticipated development within the City, replace aging assets, and comply with regulatory requirements. The Plan requires a formal adoption process that includes a hearing

before the Planning Commission, a recommendation from the Planning Commission to the City Council, and adoption by the City Council.

EXECUTIVE SUMMARY:

This new City of Wilsonville (City) Wastewater Treatment Plant (WWTP) Master Plan (the Plan) has been developed to satisfy requirements associated with the State of Oregon Department of Environmental Quality (DEQ) guidance document entitled “Preparing Wastewater Planning Documents and Environmental Reports for Public Utilities.” To accommodate future Wilsonville flows and loads, projections were developed based on population projections and referencing WWTP historical data and DEQ wet weather project methodologies. Similarly, to accommodate future water quality regulations, the Plan is adaptive and considers potential future regulatory changes.

The City prepared the Plan with the goal of developing a capital plan that identifies improvements required through the planning period (today through 2045) to comply with requirements of the WWTP National Pollutant Discharge Elimination System (NPDES) permit and potential future regulatory requirements, while accommodating growth identified in the City of Wilsonville Comprehensive Plan (October 2018, updated June 2020 - the 2018 Comprehensive Plan). These improvements are designed to provide the best value to the City’s ratepayers by maximizing the use of existing infrastructure and improving system operation while continuing to protect water quality and human health and supporting economic development, consistent with goals and policies contained in the 2018 Comprehensive Plan and 2021-2023 City Council Goals.

The City’s WWTP was originally built in 1971 and discharges treated effluent to the Willamette River. The WWTP underwent major upgrades in 2014 to expand the average dry weather capacity to four million gallons per day (mgd) to accommodate the City’s continued growth. The WWTP processes include headworks screening and grit removal facilities, aeration basins, stabilization basins, secondary clarifiers, biosolids processing, cloth filtration, and disinfection processes. Additionally, the City contracts with Jacobs for operation of the wastewater treatment plant, located at 9275 Southwest Tauchman Road.

This Plan identifies needed capital improvements within the planning period, taking into consideration:

- The age and condition of existing process equipment and structures,
- Growth in demand for sewer service due to increased population and economic development over the planning period,
- Potential changes to water quality regulations impacting process needs in order to meet effluent limitations and discharge prohibitions imposed by the DEQ, and
- Consistency with the 2018 Comprehensive Plan and City Council 2023-2025 Strategy 1.

WWTP Condition Assessment

Carollo reviewed prior condition assessments performed by others, conducted geotechnical investigations and performed seismic assessments at the WWTP in the course of Plan development.

In 2019, Jacobs Engineering Group Inc. (Jacobs) and Brown and Caldwell both completed condition assessments at the City's WWTP. A total of 322 major assets (per Jacobs' report), including process and mechanical equipment, motors and drives, control panels, generators, instrumentation, and structures, were examined for a variety of conditions that may signify their need for maintenance or replacement.

Seismic Analysis

In 2021, Carollo performed a seismic evaluation and analysis of the City's WWTP as part of the overall plant condition assessment. Because the WWTP was substantially upgraded and expanded in 2014, most of its infrastructure is designed in accordance with the 2010 Oregon Structural Specialty Code (OSSC) and follows modern seismic design and detailing. During Tier 1 evaluations, Carollo identified potential deficiencies and areas for additional investigation. A Tier 1 seismic analysis is an initial evaluation performed to identify any potential deficiencies, whether structural or non-structural, in a building based on the performance of other similar buildings in past earthquakes. Subsequent to the Tier 1 analysis, a more detailed seismic evaluation of five older and potentially seismically vulnerable structures on the WWTP site was conducted. Those structures receiving a more detailed evaluation included the following:

- Operations Building
- Process Gallery
- Workshop
- Aeration Basins and Stabilization Basins
- Sludge Storage Basins and Biofilter

The five potentially vulnerable structures were compared against an S-4 Limited Safety structural performance level and N-B Position Retention non-structural performance level for an M9.0 Cascadia Seismic Zone (CSZ) earthquake. The M9.0 CSZ is reflective of a catastrophic natural disaster event that has an estimated 35 percent likelihood of occurring within the next 50 years. Following the Tier 1 evaluation, Carollo began Tier 2 evaluations for a select number of identified deficiencies. Although none of the structures showed significant irregularities, the team did identify seismic deficiencies. The recommended seismic retrofits are included in the CIP for the Plan.

Prior to the 2021 seismic evaluation, Carollo's subconsultant, Northwest Geotech, Inc. (NGI), completed a seismic response and geologic hazards assessment of the City's WWTP. Through past and present site investigations and engineering analyses, NGI determined that the native soils beneath the site's granular pit backfill have low risk of liquefaction and its slopes do not pose undue risk. NGI concluded that the WWTP's primary site hazard is the differential settlement that may be caused by soil piping (development of subsurface air-filled voids), which raises the risk of sinkholes forming beneath structures and pipelines. Soil piping usually develops in unsaturated soils when a water source percolates into the ground. While the site is mostly paved and stormwater is being collected, there may be areas where infiltration is occurring next to structures or below pipelines. Recommended actions from NGI to mitigate the risk of soil piping are presented in the Plan.

Wastewater Flow and Load Projections

The Plan evaluates the historical and projected wastewater flows and loads generated in the City of Wilsonville’s service area. The load projections include total suspended solids (TSS), biochemical oxygen demand (BOD5), ammonia (NH3), and total phosphorous (TP) loads.

Service area, residential population, industrial contribution, and rainfall records were all considered in the flow and load projection analyses.

Capacity Analysis

Summaries of plant process area capacity assessments and conclusions are presented in the Plan. These assessments focus on the need for improvements or upgrades to existing facilities to address capacity deficiencies identified in the course of Master Plan evaluations.

Regulatory Considerations and Strategy

Several possible regulatory actions by the Oregon DEQ could drive investments in future improvements at the City’s WWTP. The plant discharges to the Willamette River and existing and future effluent limitations contained in the NPDES permit dictate, in large part, the necessary treatment processes and configuration at the WWTP necessary to maintain compliance. The existing permit limits for the Wilsonville WWTP are effective September 1, 2020 through July 30, 2025.

Alternative Development and Evaluation

The Plan presents the methodology and findings of a process improvements alternatives evaluation. The plant’s treatment process needs were defined by comparing the plant’s existing condition, capacity and reliability, with the projected flows, loads, and regulatory constraints for the recommended alternatives. Where capacity deficiencies were predicted, at least two alternatives were analyzed for each corresponding unit process.

Project Description	Timeframe	Cost*
Dewatering Performance Optimization	2025	\$150,000
Fiber Optic Conduit Addition	2025	\$60,000
UV System Improvement	2026	\$1,705,000
Seismic Improvements	2026	\$1,082,000
Geotechnical Foundation Mitigation	2026	\$2,000,000
New Aeration Basin and Blower	2025 – 2027	\$10,222,000
Replace Secondary Clarifier Mechanisms	2026 - 2027	\$1,775,000
Membrane Bioreactor (MBR) Phase 1 (includes new blower, fine screens, electrical and hydraulic upgrades)	2028 – 2031	\$69,727,000
New Solids Dryer	2031 – 2033	\$17,130,000
Thickening and Dewatering Improvements	2031 – 2033	\$3,701,000
New Cooling Tower	2035 – 2036	\$642,000
MBR Phase 2 (includes new blower)	2037 – 2039	\$2,330,000
UV Equipment Replacement and Outfall Upsizing	2039 – 2040	\$2,571,000
UV Equipment Replacement and Outfall Upsizing	2039 – 2040	\$1,244,000
MBR Phase 3 (includes 2 new blowers)	2042 – 2044	\$8,117,000
Total		\$122,456,000

*Costs are shown in 2023 dollars and include 25% for engineering, legal, and administration.

The most significant impact to the required level of capital investment is the need for membrane bioreactor (MBR) facilities. These are state-of-the-art, compact facilities that provide a high level of treatment. Due to the limited amount of space available at the existing WWTP site, MBR facilities are the only feasible means of providing the necessary treatment to accommodate build out of the Wilsonville urban reserve areas.

EXPECTED RESULTS:

The Plan includes a list of recommended capital improvements, along with an anticipated schedule for completion and preliminary cost estimates. The total estimated amount of capital investment over the planning period is approximately \$122 million, of which \$17 million is anticipated in the next 5 years. The recommended capital improvements will provide the basis for an analysis of sewer rates and system development charges (SDCs) that are necessary to adequately fund the upgrades needed to meet the projected growth.

TIMELINE:

A public hearing before City Council for the Plan adoption is anticipated in January 4, 2024, with a second reading on January 18, 2024.

CURRENT YEAR BUDGET IMPACTS:

The amended FY24 Budget for CIP #2104, Wastewater Treatment Plant Master Plan, includes \$130,000 in sewer operations and system development charge funds. The remaining budget is sufficient to complete the remaining work to update and adopt the Plan.

COMMUNITY INVOLVEMENT PROCESS:

A virtual town hall meeting to present the findings of the Plan and solicit public input was held in September 2022 and posted on the City’s online calendar and Let’s Talk Wilsonville page, where a project overview and periodic updates to the Executive Summary have also been posted. In addition, draft versions of the Executive Summary have been sent to the ten largest industrial customers for review and comment. The public hearings listed above will provide further opportunity for public input. The forthcoming Sewer System Rate Study and SDC Update will also include a public engagement process with outreach to utility customers and the development community.

POTENTIAL IMPACTS or BENEFIT TO THE COMMUNITY:

A technically and financially sound plan for providing reliable wastewater treatment, capacity to accommodate future development, and compliance with environmental regulations.

ALTERNATIVES:

The project team considered and evaluated numerous technologies and alternatives to provide the needed wastewater treatment plant capacity to meet future demands and recommend a capital improvement program that implements the needed improvements in a way that is efficient and cost effective.

ATTACHMENTS:

1. Wastewater Treatment Plant Master Plan (dated December 2023)
2. Wastewater Treatment Plant Master Plan Appendices (dated December 2023)
3. Conclusionary Findings
4. Master Plan Record (electronic only)



City of Wilsonville

WASTEWATER TREATMENT PLANT MASTER PLAN

FINAL | December 2023





City of Wilsonville

WASTEWATER TREATMENT PLANT MASTER PLAN

FINAL | December 2023

Contents

Executive Summary

ES.1 Planning Area Characteristics	ES-2
ES.2 WWTP Condition Assessment	ES-5
ES.3 Seismic Analysis	ES-6
ES.4 Wastewater Flow and Load Projections	ES-7
ES.5 Capacity Analysis	ES-10
ES.6 Regulatory Considerations and Strategy	ES-16
ES.7 Alternative Development and Evaluation	ES-17
ES.8 Recommended Alternative	ES-20

Chapter 1 - Planning Area Characteristics

1.1 Introduction	1-1
1.1.1 Background	1-1
1.1.2 Scope	1-2
1.1.3 Reference Studies and Sources	1-2
1.2 Plan Requirements	1-3
1.2.1 Oregon DEQ Wastewater Facility Planning Guide, July 2019	1-3
1.2.2 Oregon's Integrated Water Resources Strategy, 2017 Update	1-3
1.2.3 Statewide Land Use Goal 11, 2005 Update	1-3
1.3 Project Planning Area	1-3
1.3.1 Service Area Definition	1-3
1.3.2 Existing Conveyance and Treatment Facilities	1-4
1.4 Land Use	1-9
1.4.1 Locally Adopted Comprehensive Plans	1-9
1.5 Physical Characteristics	1-10
1.5.1 Climate	1-10
1.5.2 Topography	1-10
1.5.3 Geology and Soils	1-15
1.5.4 Environmentally Sensitive Areas and Species	1-16
1.5.5 Cultural Resources	1-18

1.5.6 Regional Hazards	1-18
1.5.7 WWTP Surrounding Area	1-21
1.6 Water Resources	1-21
1.7 Population and Employment	1-25
1.7.1 Local Industry and Significant Non-Residential Dischargers	1-25
1.7.2 Socio-Economic Trends	1-25
1.7.3 Current Service Area Populations	1-27
1.7.4 Population Projections	1-27
Chapter 2 - Condition Assessment and Tier 1 Seismic Analysis Summary	
2.1 Summary of Condition Assessment	2-1
2.2 Summary of Seismic Evaluation and Analysis	2-4
2.3 Summary of Geologic Hazards Assessment	2-8
Chapter 3 - Wastewater Flow and Load Projections	
3.1 Planning Basis	3-1
3.1.1 Current and Future Population	3-1
3.1.2 Precipitation	3-3
3.2 Historical and Existing Flows	3-5
3.2.1 Flow Parameters	3-6
3.2.2 Industrial Contribution	3-7
3.2.3 Average Flows	3-8
3.2.4 Maximum Month Flows	3-13
3.2.5 Maximum Weekly Flows	3-17
3.2.6 Peak Day Flows	3-19
3.2.7 Peak Hour Flow	3-22
3.2.8 Existing Flow Summary	3-24
3.3 Flow Projections	3-24
3.3.1 Industrial Flow Projection	3-24
3.3.2 Total Influent Flow Projection	3-27
3.4 Historical and Existing Loads	3-29
3.4.1 Total Suspended Solids	3-30
3.4.2 Biochemical Oxygen Demand	3-35

3.4.3 Ammonia	3-39
3.4.4 Phosphorous	3-45
3.5 Load Projections	3-45
3.5.1 Industrial Load Projection	3-45
3.5.2 Total Influent Load Projection	3-50
Chapter 4 - Capacity Analysis	
4.1 Introduction	4-1
4.2 Design Criteria	4-1
4.3 Unit Process Capacity	4-5
4.3.1 Preliminary Treatment	4-5
4.3.2 Secondary Treatment	4-7
4.3.3 Tertiary Treatment and Disinfection	4-19
4.3.4 Solids Handling	4-24
4.3.5 Plant Hydraulics	4-28
4.4 Summary of Key Capacity Issues	4-29
Chapter 5 - Regulatory Considerations and Strategy	
5.1 Willamette River Flow	5-1
5.2 Regulatory Framework	5-3
5.3 Beneficial Uses	5-4
5.4 Oregon Administrative Rules for Wastewater Treatment	5-4
5.5 Total Maximum Daily Loads	5-5
5.6 Cold Water Refuge	5-5
5.7 Clean Water Act 303 (d) Listing	5-6
5.8 Permit Limits	5-7
5.9 Outfall	5-8
5.10 Toxicity	5-8
5.11 Temperature	5-9
5.12 Future treatment requirements	5-11
5.13 Mass Load	5-11
5.14 Dissolved Oxygen	5-12
5.15 Nutrients	5-12

5.16 Triennial Review	5-12
5.17 Pre-Treatment Limit Evaluation	5-13
Chapter 6 - Alternatives Development and Evaluation	
6.1 Introduction	6-1
6.2 Secondary Treatment	6-2
6.2.1 Conventional Secondary Expansion	6-2
6.2.2 Intensification	6-6
6.2.3 Secondary Expansion Phasing	6-14
6.3 Tertiary Treatment	6-16
6.4 Effluent Cooling – Cooling Towers and Other Considerations	6-16
6.5 Solids Handling	6-19
6.5.1 Dewatering	6-19
6.5.2 Solids Dryer	6-21
6.5.3 Solids Drying Alternatives Comparison	6-30
6.6 Fiber Optic Cable Addition	6-31
Chapter 7 - Recommended Alternative	
7.1 Introduction	7-1
7.2 Summary	7-2
7.3 Recommended Improvements	7-3
7.3.1 Liquid Treatment System Improvements	7-4
7.3.2 Solids Treatment System Improvements	7-5
7.3.3 Seismic and Geologic Hazard Recommendations	7-9
7.3.4 Fiber Optic Cable Addition	7-10
7.4 Site Plan	7-10
7.5 Planning Level Opinion of Probable Cost and Phasing	7-10
7.6 Project Schedule and Phasing	7-13
7.7 Financial Analysis – Capital Improvement Plan	7-15
Appendices	
Appendix A	Jacobs Condition Assessment 2019
Appendix B	Brown and Caldwell Condition Assessment 2019
Appendix C	Ovivo Field Service Report
Appendix D	Seismic Evaluation

Appendix E	Sesimic Response and Geologic Hazards Assessment
Appendix F	Geotechnical Assessment TM 2023
Appendix G	WASTEWATER TREATMENT PLANT SCHEMATICS
Appendix H	Jacobs Hydraulic Analysis TM 2023
Appendix I	Penny Carolo Considerations for Next Pretreatment Local Limits Evaluation
Appendix J	Class 5 Cost Estimates
Appendix K	Backup UV Replacement and Dewatering Equipment Replacement Cost Estimates

Tables

Table ES.1	CIP Condition Driven Replacement Projects	ES-6
Table ES.2	Unit Process Capacity Assessment	ES-13
Table ES.3	Unit Process Capacity Year Summary	ES-15
Table ES.4	Current Effluent Permit Limits	ES-16
Table ES.5	Summary of Alternatives	ES-19
Table ES.6	WWTP CIP - Recommended Alternative Opinion of Probable Cost and Phasing	ES-21
Table 1.1	Hydrologic Soil Groups	1-15
Table 1.2	Aquatic Species Status	1-16
Table 1.3	Key Conservation Issues of Concern in Willamette Valley Ecoregion	1-17
Table 1.4	Strategy Habitats in the Willamette Valley Ecoregion	1-17
Table 1.5	IWRS Recommended Actions for Wastewater Planning	1-21
Table 1.6	City of Wilsonville Socio-Economic Trends(1)	1-26
Table 1.7	Historical Population Estimates(1)	1-27
Table 1.8	Summary of Build-out Population Projections(1)	1-27
Table 2.1	Assets Excluded from the 2019 Condition Assessments	2-1
Table 2.2	Assets Recently Replaced or Refurbished	2-2
Table 2.3	Critical Assets Needing Short-term Rehabilitation or Replacement	2-3
Table 2.4	Less Critical Assets for Short-term Improvement	2-4
Table 2.5	List of Structures Included in Tier 2 Seismic Analysis	2-5
Table 2.6	List of Seismic Deficiencies at the City WWTP	2-6
Table 2.7	Summary of Estimated Retrofit Cost	2-7
Table 3.1	Annual Historical Rainfall Stats	3-5

Table 3.2	Annual Average and Maximum Monthly Industrial Contributions	3-8
Table 3.3	Average Base Flow	3-9
Table 3.4	Average Annual Flow	3-10
Table 3.5	Average Dry Weather Flow	3-11
Table 3.6	Average Wet Weather Flow	3-13
Table 3.7	Direct MMDWF Calculations	3-14
Table 3.8	Maximum Month Dry Weather Flows and Peaking Factors	3-15
Table 3.9	Direct MMWWF Calculations	3-16
Table 3.10	Maximum Month Wet Weather Flows and Peaking Factors	3-17
Table 3.11	Maximum Week Dry Weather Flows and Peaking Factors	3-18
Table 3.12	Maximum Week Wet Weather Flows and Peaking Factors	3-19
Table 3.13	Peak Day Dry Weather Flows and Peaking Factors	3-20
Table 3.14	Peak Day Wet Weather Flows and Peaking Factors	3-21
Table 3.15	Peak Hour R/C Flows Peaking Factors	3-23
Table 3.16	Existing (2020) Flow Summary	3-24
Table 3.17	Industrial Flow Projections for the Current Industrial Area	3-26
Table 3.18	Industrial Flow Projections	3-27
Table 3.19	2045 Flow Projections	3-27
Table 3.20	Comparison of 2045 CSMP Flow Projections to the Current Plan's Projections	3-28
Table 3.21	Annual Average and Maximum Monthly Industrial TSS Contributions	3-31
Table 3.22	Average Annual TSS Load	3-32
Table 3.23	Maximum Month TSS Loads and Peaking Factors	3-33
Table 3.24	Maximum Week TSS Loads and Peaking Factors	3-34
Table 3.25	Peak Day TSS Loads and Peaking Factors	3-35
Table 3.26	TSS Existing Loads Summary	3-35
Table 3.27	Annual Average and Maximum Monthly Industrial BOD ₅ Contributions	3-36
Table 3.28	Average Annual BOD ₅ Load	3-36
Table 3.29	Maximum Month BOD ₅ Loads and Peaking Factors	3-37
Table 3.30	Maximum Week BOD ₅ Loads and Peaking Factors	3-38
Table 3.31	Peak Day BOD ₅ Loads and Peaking Factors	3-39
Table 3.32	BOD ₅ Existing Loads Summary	3-39

Table 3.33	Estimated Annual Average and Maximum Monthly Industrial Ammonia Contributions	3-40
Table 3.34	Average Annual Ammonia Load	3-41
Table 3.35	Maximum Month Ammonia Loads and Peaking Factors	3-42
Table 3.36	Maximum Week Ammonia Loads and Peaking Factors	3-43
Table 3.37	Peak Day Ammonia Loads and Peaking Factors	3-44
Table 3.38	Ammonia Existing Loads Summary	3-44
Table 3.39	Estimate of Existing Total Phosphorous Loads	3-45
Table 3.40	Industrial TSS Load Projections for Permitted Industrial Users within the Current Industrial Area	3-47
Table 3.41	Industrial BOD ₅ Load Projections for Permitted Industrial Users within the Current Industrial Area	3-47
Table 3.42	Industrial TSS Load Projections	3-48
Table 3.43	Industrial BOD ₅ Load Projections	3-48
Table 3.44	2045 Industrial Load Summary	3-49
Table 3.45	Load Projections for the year 2045	3-50
Table 4.1	Unit Process Capacity Summary	4-3
Table 4.2	BioWin Model Wastewater Characteristics	4-14
Table 4.3	BioWin Model Calibration Summary	4-15
Table 4.4	Unit Process Capacity Year Summary	4-29
Table 5.1	Willamette River Flow Data from the USGS Station in Newberg	5-1
Table 5.2	Willamette River Statistical Flows	5-2
Table 5.3	Dilution Factors from Mixing Zone Study	5-3
Table 5.4	Designated Beneficial Uses for the Willamette River from the Willamette Falls to Newberg	5-4
Table 5.5	Temperature TMDL Allocations	5-5
Table 5.6	Effluent Permit Limits	5-7
Table 5.7	Permitted Mass Load Limits Impact on Allowable Concentrations	5-11
Table 5.8	Initial List of POCs for the Local Limits Evaluation	5-14
Table 6.1	New Aeration Basin Opinion of Probable Cost	6-5
Table 6.2	Suppliers of IFAS Systems Nitrogen Removal Alternative Evaluation, City of Porterville	6-8
Table 6.3	Comparison of Intensification Technologies	6-10
Table 6.4	MBR Opinion of Probable Cost	6-14

Table 6.5	New Cooling Tower Opinion of Probable Cost	6-19
Table 6.6	Opinion of Probable Costs for Alternatives 2a, 2b, and 2c	6-28
Table 6.7	Opinion of Probable Cost for Alternative 3	6-30
Table 6.8	Fiber Optic Cable Addition Opinion of Probable Cost	6-31
Table 7.1	Recommended Plan Through the Year 2045	7-2
Table 7.2	Summary of Estimated Retrofit Opinion of Probable Cost	7-9
Table 7.3	WWTP Recommended Alternative Opinion of Probable Cost and	7-12
Table 7.4	Phasing Cash Flow Summary	7-17

Figures

Figure ES.1	Planning Area	ES-3
Figure ES.2	Historical Population and Expected Growth for the City of Wilsonville	ES-5
Figure ES.3	Flow Projection Summary	ES-9
Figure ES.4	Load Projection Summary	ES-10
Figure ES.5	Existing Wilsonville WWTP	ES-11
Figure ES.6	Proposed WWTP Improvements Site Plan	ES-23
Figure ES.7	Projected 20-Year CIP Expenditures	ES-24
Figure ES.8	Capacity Trigger Graph	ES-25
Figure 1.1	Planning Area	1-5
Figure 1.2	Conveyance Infrastructure and Treatment Facility	1-7
Figure 1.3	City Land Use Designations	1-11
Figure 1.4	Topography	1-13
Figure 1.5	Landslide Hazards	1-19
Figure 1.6	WWTP Vicinity Map	1-23
Figure 3.1	Historical Population and Expected Growth for the City of Wilsonville	3-3
Figure 3.2	City of Wilsonville UGB	3-4
Figure 3.3	Average Monthly Rainfall at the Aurora Airport	3-5
Figure 3.4	Average Wet Weather Flow DEQ Methodology	3-12
Figure 3.5	Maximum Month Dry Weather Flow DEQ Methodology	3-15
Figure 3.6	Maximum Month Wet Weather Flow DEQ Methodology	3-16
Figure 3.7	Peak Day Wet Weather Flow DEQ Methodology	3-21
Figure 3.8	Peak Hour Flow DEQ Methodology	3-22
Figure 4.1	Mechanical Screening Capacity	4-6

Figure 4.2	Grit Removal Capacity	4-7
Figure 4.3	Historical Solids Retention Time	4-9
Figure 4.4	Historical Aeration Basin Mixed Liquor Suspended Solids	4-10
Figure 4.5	Historical Final Effluent Ammonia Concentration	4-11
Figure 4.6	Historical Final Effluent TSS Loading	4-12
Figure 4.7	Historical Sludge Volume Index	4-13
Figure 4.8	SPA for 2045 Max Week MLSS at Peak Day Flow	4-17
Figure 4.9	Secondary Treatment Capacity	4-18
Figure 4.10	Secondary Clarifier Capacity (Surface Overflow Rate)	4-18
Figure 4.11	Disc Filter Hydraulic Capacity	4-20
Figure 4.12	Cooling Tower Capacity	4-22
Figure 4.13	UV Disinfection Capacity	4-23
Figure 4.14	Outfall Hydraulic Capacity	4-24
Figure 4.15	Historical Gravity Belt Thickener Performance	4-25
Figure 4.16	Gravity Belt Thickener Capacity	4-26
Figure 4.17	Dewatering Centrifuge Solids Loading Capacity	4-27
Figure 4.18	Biosolids Dryer Capacity	4-28
Figure 5.1	Historical Flow of the Willamette River at Newberg	5-2
Figure 5.2	Effluent temperatures from 2015 through 2019	5-9
Figure 5.3	DMR-Reported ETL Discharged Compared to the NPDES Permit of 39 million kCal/day	5-9
Figure 5.4	2018 Thermal Load versus Option A and Option B limits	5-10
Figure 6.1	Proposed Fourth Aeration Basin Site Plan	6-3
Figure 6.2	Proposed Mixed Liquor Splitter Box Modification (Section)	6-4
Figure 6.3	Proposed Retaining Wall Dimension	6-5
Figure 6.4	Sample BioMag® System Schematic	6-7
Figure 6.5	Examples of “Wagon Wheel” and Sponge Media Used in an IFAS Technology	6-8
Figure 6.6	MBR Schematic	6-9
Figure 6.7	Potential MBR and Fine Screen Facility Site Plan	6-12
Figure 6.8	Proposed Modifications to Blower Canopy	6-13
Figure 6.9	Proposed Cooling Tower Layout	6-18

Figure 6.10	Andritz Solids Paddle Dryer Layout in Existing Dewatering and Dryer Building	6-23
Figure 6.11	Dewatering and Dryer Building Expansion for Redundant Solids Paddle Dryer	6-25
Figure 6.12	Dewatering and Dryer Building Modification for Drum Dryer System	6-27
Figure 6.13	Proposed New Solids Dryer Site Plan	6-29
Figure 6.14	Proposed Fiber Optic Cable Addition	6-31
Figure 7.1	Capacity Trigger Graph	7-3
Figure 7.2	Simplified Liquid Stream Process Flow Diagram	7-7
Figure 7.3	Proposed WWTP Improvements Site Plan	7-11
Figure 7.4	Recommended Project Phasing Schedule	7-14
Figure 7.5	Projected 20-Year CIP Expenditures	7-16

Abbreviations

°C	degrees Celsius
°F	degrees Fahrenheit
AA	average annual
AACEI	Association for the Advancement of Cost Engineering's
AAF	average annual flow
ABF	average base flow
ACCU	air cooled condensing unit
ACI	American Concrete Institute
ACS	American Community Survey
ADW	average dry weather
ADWF	average dry-weather flow
ASCE	American Society of Civil Engineers
aSRT	aerobic solids retention time
AWWF	average wet weather flow
BCPA	Basalt Creek Planning Area
BCR	biochemical reactor
BFP	belt filter press
BOD	biochemical oxygen demand
BOD5	biochemical oxygen demand
BSE	basic safety earthquakes
Carollo	Carollo Engineers, Inc.
CBOD	carbonaceous biochemical oxygen demand
CBOD5	five-day carbonaceous biochemical oxygen demand
CCCCF	Coffee Creek Correctional Facility
cfs	cubic feet per second
CIP	capital improvement plan
City	City of Wilsonville
CMU	concrete masonry
COD	chemical oxygen demand
CRB	Columbia River Basalts
CSMP	Collection System Master Plan
CSZ	Cascadia Seismic Zone
CWR	cold water refuge
cy	cubic yard(s)
DBO	Design-Build-Operate
DDT	dichlorodiphenyltrichloroethane
DEQ	Department of Environmental Quality

DMA	designated management agencies
DMR	Discharge Monitoring Reports
DOGAMI	Department of Geology and Mineral Industries
EDI	electronic data interchange
ELA	engineering, legal and administration fees
EPA	Environmental Protection Agency
ETL	excess thermal load
FEMA	Federal Emergency Management Agency
ft/hr	feet per hour
GBT	gravity belt thickener
Goal 11	Land Use Goal 11
gpad	gallon(s) per acre per day
gpcd	gallons(s) per capita per day
gpd	gallons per day
gpd/sf	gallons per day per square foot
gpm	gallons per minute
gpm	gallons per minute
Guide	Wastewater Facility Planning Guide
HMI	human-machine interface
hr	hour(s)
HSD	Historic Sites Database
I-5	Interstate-5
IFAS	integrated fixed film active sludge
IWRS	Integrated Water Resources Strategy
Jacobs	Jacobs Engineering Group Inc.
kcal/day	kilocalories per day
kg/year	kilogram(s) per year
L/g	liters per gram
lbs	pounds
M9.0	magnitude 9.0
MBR	membrane bioreactor
Metro	Oregon Metro
MFD	Missoula flood deposit
mg/L	milligrams per liter
mgd	million gallons per day
Middle Willamette	Coffee Lake Creek-Willamette River Watershed
ml	milliliter
mL/g	milliliters per gram
MLR	mixed liquor recycle

MLSS	mixed liquor suspended solids
MLVSS	mixed liquor volatile suspended solids
mm	millimeter
MM	maximum month
MMF	maximum month flows
MMWWF	maximum month wet weather flow
MW	maximum week
MWDWF	maximum week dry weather flow
MWWWF	maximum week wet weather flow
N/A	not applicable
NGI	Northwest Geotech, Inc.
NH3	ammonia
NH3-N	Ammonia (as Nitrogen)
No.	number
NOAA	National Oceanic and Atmospheric Administration
NPDES	National Pollutant Discharge Elimination System
NRCS	Natural Resources Conservation Service
O&M	operation and maintenance
OAR	Oregon Administrative Rule
ODFW	Oregon Department of Fish and Wildlife
ODOC	Oregon Department of Corrections
ODOT	Oregon Department of Transportation
OSSC	Oregon Structural Specialty Code
PD	peak day
PDDWF	peak day dry weather flow
PDF	peak day flow
PHF	peak hour flow
Plan	Wastewater Treatment Plant Master Plan
ppcd	pounds per capita day
ppd	pounds per day
psi	pound(s) per square inch
PSU PRC	Portland State University Population Research Center
R/C	residential/commercial
RAS	return activated sludge
RM	river mile
RMZ	regulatory mixing zone
RPA	Reasonable Potential Analysis
s/cm2	square centimeter per second
scfm	standard cubic foot/feet per minute

SERP	State Environmental Review Process
sf	square feet
SIU	significant impact user
SNAP	Supplemental Nutrition Assistance Program
SOR	surface overflow rate
SPA	state point analysis
SRF	State Revolving Fund
SROZ	Significant Resource Overland Zone
SRT	solids residence time
SVI	sludge volume index
TAZ	Transportation Analysis Zone
TDH	total dynamic head
TKN	total kjeldahl nitrogen
TMDL	total maximum daily loads
TP	total phosphorous
TS	total solids
TSS	total suspended solids
TWAS	thickened waste activated sludge
UGB	urban growth boundary
URA	Urban reserve area
USGS	U.S. Geological Survey
UV	ultraviolet
UVT	ultraviolet transmissivity
VFA	volatile fatty acids
VFD	variable frequency drive
VSS	volatile suspended solids
WAS	waste activated sludge
WSMP	Water System Master Plan
WWTP	wastewater treatment plant
ZID	zone of initial dilution

EXECUTIVE SUMMARY

This new City of Wilsonville (City) Wastewater Treatment Plant (WWTP) Master Plan (the Plan) has been developed to satisfy requirements associated with the State of Oregon Department of Environmental Quality (DEQ) guidance document entitled “Preparing Wastewater Planning Documents and Environmental Reports for Public Utilities.” To accommodate future flows and loads, projections were developed based on population projections and referencing WWTP historical data and DEQ wet weather projection methodologies. Similarly, to accommodate future water quality regulations, the Plan is adaptive and considers potential future regulatory changes.

The City prepared the Plan with the goal of developing a capital plan that identifies improvements required through the planning period (today through 2045) to comply with requirements of the WWTP National Pollutant Discharge Elimination System (NPDES) permit and potential future regulatory requirements, while accommodating growth identified in the City of Wilsonville Comprehensive Plan (October 2018, updated June 2020 - the 2018 Comprehensive Plan). These improvements are designed to provide the best value to the City’s ratepayers by maximizing the use of existing infrastructure and improving system operation while continuing to protect water quality and human health and supporting economic development, consistent with goals and policies contained in the 2018 Comprehensive Plan and 2021-2023 City Council Goals.

The City’s WWTP was originally built in the early 1970’s and discharges treated effluent to the Willamette River. The WWTP underwent major upgrades in 2014 to expand the average dry weather capacity to four million gallons per day (mgd) to accommodate the City’s continued growth. The WWTP processes include headworks screening and grit removal facilities, aeration basins, stabilization basins, secondary clarifiers, biosolids processing, cloth filtration, and disinfection processes. Additionally, the City contracts with Jacobs for operation of the WWTP, located at 9275 Southwest Tauchman Road.

This Plan identifies improvements taking into consideration:

- The age and condition of existing process equipment and structures,
- Growth in demand for sewer service due to increased population and economic development over the planning period,
- Potential changes to water quality regulations impacting process needs in order to meet effluent limitations and discharge prohibitions imposed by DEQ,
- City of Wilsonville Wastewater Collection System Master Plan (2014, MSA), and
- Consistency with the 2018 Comprehensive Plan and City Council 2023-2025 Strategy 1.

ES.1 Planning Area Characteristics

Chapter 1 summarizes the City's wastewater service area characteristics relevant to assessing WWTP facility needs. The planning area considered by this Plan is consistent with the City's 2014 Collection System Master Plan and 2018 Comprehensive Plan including the urban growth boundary (UGB). The Basalt Creek Concept Plan, adopted in 2018, resulted in a modification of the future boundary between the cities of Tualatin and Wilsonville relative to the 2014 Wastewater Collection System Master Plan (CSMP). This decision is reflected in Figure ES.1, which shows the Study Area Boundary as analyzed in the 2014 CSMP, with the portion likely to annex to Tualatin now shown outside the current Study Area Boundary.

The northern portion of the City of Wilsonville is located within Washington County, and the majority of the City lies in the southwestern part of Clackamas County.

The City sits within the jurisdictional boundaries of Metro, the regional government for the Portland metropolitan area. By state law, Metro is responsible for establishing the Portland metropolitan area's UGB, which includes Wilsonville. Land uses and densities inside the UGB require urban services such as police and fire protection, roads, schools, and water and sewer systems. A figure of the City's existing land use is presented in Chapter 1.

Also presented in Chapter 1 are the City's physical characteristics, water resources, and population and employment information, which are all significant factors in planning for wastewater conveyance and treatment facilities.

EXECUTIVE SUMMARY | WASTEWATER TREATMENT PLANT MASTER PLAN | CITY OF WILSONVILLE

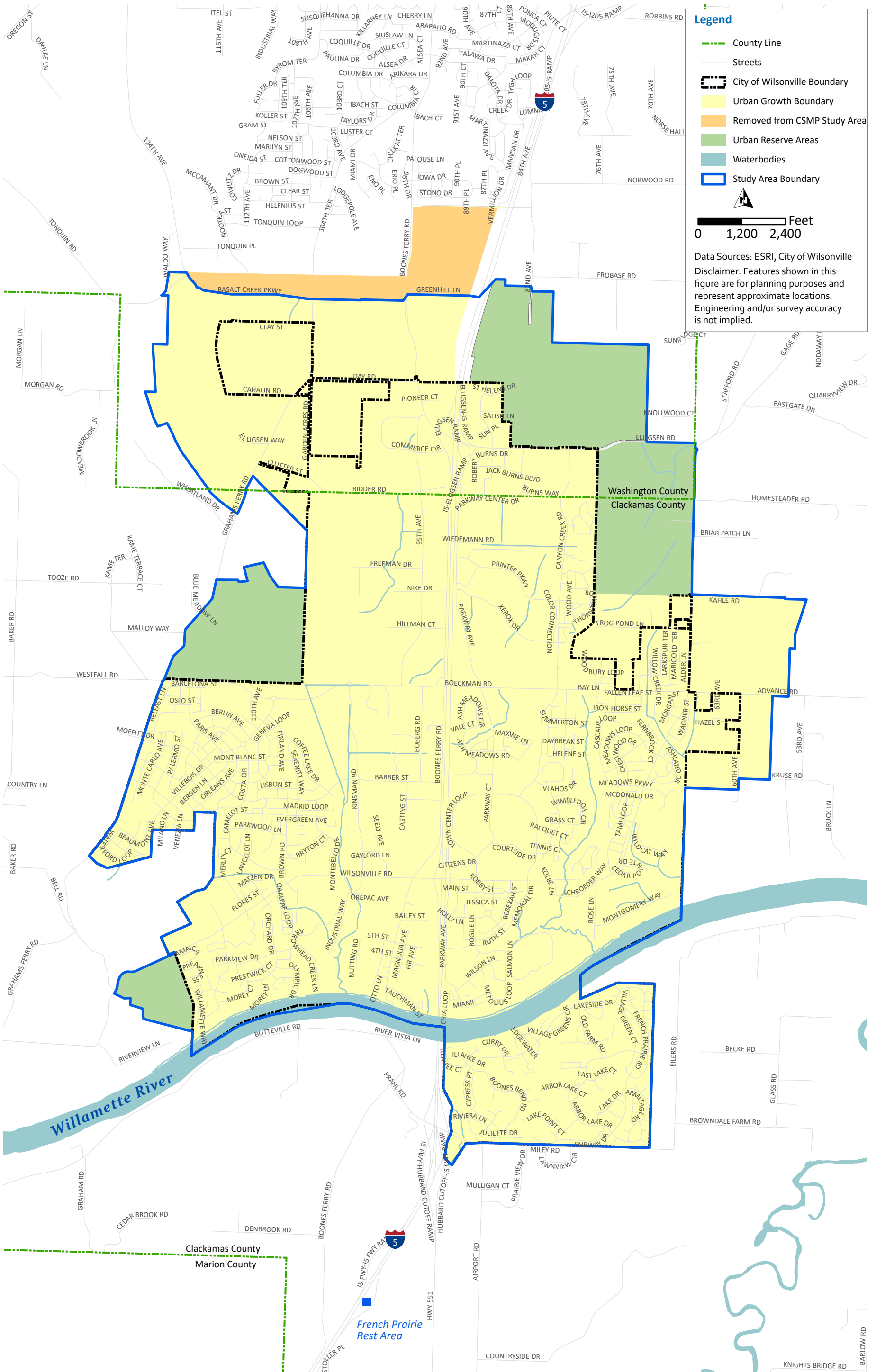

The Portland State University Population Research Center (PSU PRC) publishes annual estimates of populations for the previous year for cities in Oregon while Metro develops population projections for the future within the Portland metropolitan area, including Wilsonville. The PSU PRC estimated the City's population as 27,414 in 2022.

The historical per capita flow and loads presented in this master plan are based on the PSU PRC certified population estimates while future flow and load projections are based on the CSMP estimates to maintain consistency with prior water and sewer enterprise planning (with the slight modification to exclude the portion of the Basalt Creek Planning Area (BCPA) mentioned above). Figure ES.2 details the current population along with the historical population and growth expected for the City using the CSMP projections. As is shown in Figure ES.2, the WSMP (2003) assumption of a 2.9 percent growth rate lines up well with the PSU PRC and US census data for the years 2010 through 2022. Current and future population are described in greater detail in Chapter 3.

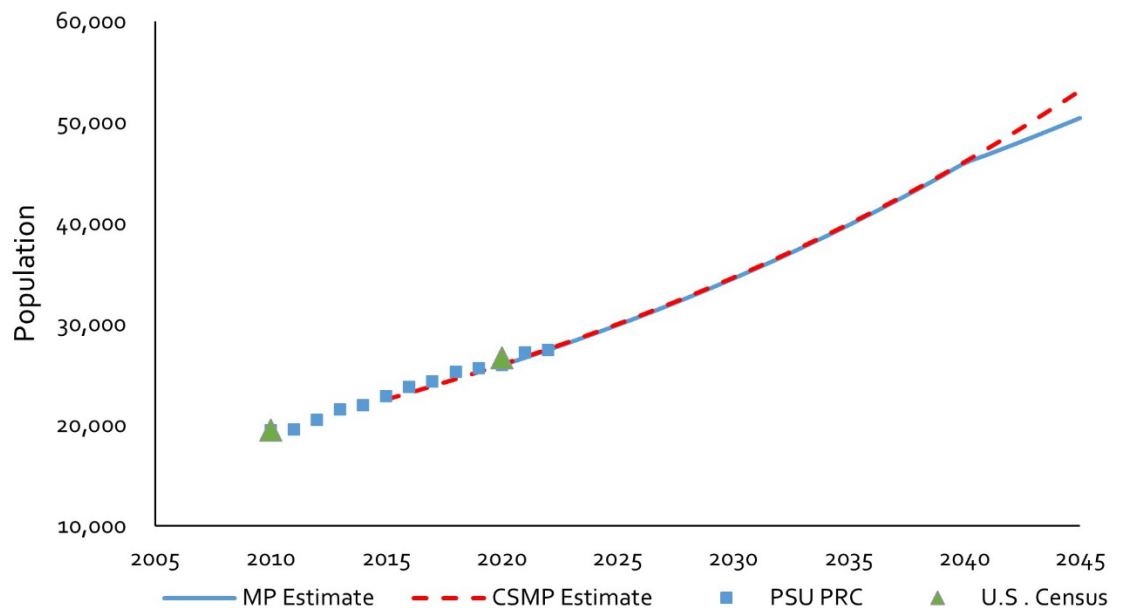

Figure ES.2 Historical Population and Expected Growth for the City of Wilsonville

ES.2 WWTP Condition Assessment

Carollo Engineers, Inc. (Carollo) reviewed prior condition assessments performed by others, conducted geotechnical investigations and performed seismic assessments at the WWTP in the course of Plan development.

In 2019, Jacobs Engineering Group Inc. (Jacobs) and Brown and Caldwell both completed condition assessments at the City’s WWTP. A total of 322 major assets (per Jacobs’ report), including process and mechanical equipment, motors and drives, control panels, generators, instrumentation, and structures, were examined for a variety of conditions that may signify their need for maintenance or replacement. Chapter 2 presents a summary of critical assets that require short term rehabilitation or replacement, as well as a list of assets that are less critical to operations, or have minor condition issues, but may be included in a short-term improvements project or a task order for Jacobs operations personnel. Table ES.1 displays the condition driven rehabilitation or replacement projects from Chapter 2 that were included in the recommended Capital Improvement Plan (CIP) in Chapter 7. The City undertook an updated assessment of WWTP condition in the summer of 2023. The 2023 assessment did not identify additional issues requiring significant capital outlays compared to the 2019 assessments.

Table ES.1 CIP Condition Driven Replacement Projects

Asset	Description
Trojan UV 4000 System	While only used as a backup to the Suez UV system, the Trojan system’s HMI has errors that prevent it from showing the status of the lamps in module 3. Since it is used infrequently, the system’s condition is largely unknown. After review of the 2019 condition assessment reports and discussion with the City and Jacobs staff, it was concluded that the UV 4000 unit must be replaced.
Secondary Clarifiers No. 1 and No. 2	Ovivo completed a field review of the plant’s secondary clarifiers No. 1 and No. 2 in April 2022. Although both units were operational, repairs were identified to improve the operation of the clarifiers. The recommended repairs include drive controls for both units, new skimmers for both units, squeegees for both tanks rake arms, EDI chains, one motor and reducer assembly, one skimmer arm assembly, and new secondary clarifier mechanisms.

Notes:

Abbreviations: EDI - electronic data interchange; HMI - human-machine interface; No. - number; UV - ultraviolet.

ES.3 Seismic Analysis

In 2021, Carollo performed a seismic evaluation and analysis of the City’s WWTP as part of the overall plant condition assessment. Because the WWTP was substantially upgraded and expanded in 2014, most of its infrastructure is designed in accordance with the 2010 Oregon Structural Specialty Code (OSSC) and follows modern seismic design and detailing. During Tier 1 evaluations, Carollo identified potential deficiencies and areas for additional investigation. A Tier 1 seismic analysis is an initial evaluation performed to identify any potential deficiencies, whether structural or non-structural, in a building based on the performance of other similar buildings in past earthquakes. Subsequent to the Tier 1 analysis, a more detailed seismic evaluation of five older and potentially seismically vulnerable structures on the WWTP site was conducted. Those structures receiving a more detailed evaluation included the following:

- Operations Building.
- Process Gallery.
- Workshop.
- Aeration Basins and Stabilization Basins.
- Sludge Storage Basins and Biofilter.

The five potentially vulnerable structures were compared against an S-4 Limited Safety structural performance level and N-B Position Retention non-structural performance level for an M9.0 Cascadia Seismic Zone (CSZ) earthquake. The M9.0 CSZ is reflective of a catastrophic natural disaster event that has an estimated 35 percent likelihood of occurring within the next 50 years. Following the Tier 1 evaluation, Carollo began Tier 2 evaluations for a select number of identified deficiencies. Although none of the structures showed significant irregularities, the team did identify seismic deficiencies. The recommended seismic retrofits are included in the CIP for this Plan.

Prior to the 2021 seismic evaluation, Carollo's subconsultant, Northwest Geotech, Inc. (NGI), completed a seismic response and geologic hazards assessment of the City's WWTP. Through past and present site investigations and engineering analyses, NGI determined that the native soils beneath the site's granular pit backfill have low risk of liquefaction and its slopes do not pose undue risk. NGI concluded that the WWTP's primary site hazard is the differential settlement that may be caused by soil piping (development of subsurface air-filled voids), which raises the risk of sinkholes forming beneath structures and pipelines. Soil piping usually develops in unsaturated soils when a water source percolates into the ground. While the site is mostly paved and stormwater is being collected, there may be areas where infiltration is occurring next to structures or below pipelines. In spring 2023, NGI performed a visual crack survey and mapped existing cracks at accessible structure floor and foundation stem wall locations. In addition, NGI completed a 50-foot boring utilizing a sonic drilling technique to assist in determining grouting conditions, prior maximum excavation depths, and fill materials present in the vicinity of secondary clarifier 3. Recommended actions from NGI to mitigate the risk of soil piping and considerations for new structure foundations are presented in Chapter 2. The City intends to evaluate the need and extent of ground improvement for WWTP structures during preliminary design of seismic upgrades. Accordingly, an allowance for future foundation mitigation measures of \$2 million is included in the City's CIP.

ES.4 Wastewater Flow and Load Projections

Chapter 3 of the Plan evaluates the historical and projected wastewater flows and loads generated in the City of Wilsonville's service area. The load projections include total suspended solids (TSS), biochemical oxygen demand (BOD₅), ammonia (NH₃), and total phosphorous (TP) loads.

Service area, residential population, industrial contribution, and rainfall records were all considered in the flow and load projection analyses. Facility planning involves estimating rates of growth in wastewater generation within the service area which are unlikely to align precisely with the actual growth observed. During the planning period, City staff will need to assess service area growth at regular intervals and revisit the analysis presented in this Plan.

The City previously estimated population for build-out of their service area. These estimates were taken from the City's Collection System Master Plan (2014, MSA) and as assumed in that document, projected the UGB reaches build-out in 2045. Figure ES.2 details the historical population and growth expected for the City. In addition, the City service area boundary upon which 2045 UGB build-out projections were based on the 2014 CSMP, has been altered slightly to account for a portion of the Basalt Creek Planning Area (BCPA) which is now expected to annex to the City of Tualatin and therefore will not receive wastewater service from the City of

Wilsonville. Figure ES.2 illustrates the 2014 UGB build-out population projections from the CSMP compared to those based on the modified service area boundary.

The flow and load projections presented in Chapter 3 are based on the Collection System Master Plan projections (with the slight modification to exclude the portion of the BCPA mentioned above).

A determination will need to be made whether projected flows and loads (which drive assessments of unit process capacity) are aligned with calendar projections presented in this plan and consider if conclusions presented regarding capacity and timing of recommended improvements remain valid. If not, adjustments to the plan will need to be undertaken to ensure sufficient capacity remains available to serve anticipated growth. As actual future wastewater generation rates may also be slightly different than the unit factors considered in this Plan, operations staff at the plant will need to be familiar with the flow and load triggers for planning and design of logical increments of treatment capacity presented in this plan. If growth rates are higher, the schedule for improvements in this plan will need to align with calendar dates presented herein. If growth occurs more slowly, the City will be able to phase WWTP improvements on a less aggressive schedule.

Analysis of flow projections were completed through two different methods: (1) analysis of historical plant records and (2) DEQ Guidelines for Making Wet-Weather and Peak Flow Projections for Sewage Treatment in Western Oregon, which is referred to as the DEQ methodology in this Plan. Since there is no DEQ methodology for load analysis, all projections were developed based on historical plant records. Figure ES.3 summarizes the measured and projected maximum month, peak day and peak hour flows. The projections for the remaining flow elements can be found in Chapter 3. As is shown in Figure ES.3, the peak hour flow is projected to exceed the peak hour flow of 16 mgd listed on the 2014 Improvements Drawings close to the year 2040. The projected 2045 peak hour flow is based on a 10-year (rather than a 5-year) design storm and does not account for storage or flow attenuation in the collection system. In 2023 the City undertook a hydraulic analysis of the WWTP concluding that certain elements will be deficient as the service area develops. This is discussed in greater detail in Chapter 4. This has important implications for facility improvement costs recommended in this Master Plan, which are based on estimates and projections of flows and loads which may not align with the timelines presented in this Master Plan. As such it is recommended the City perform additional evaluation of the WWTP and collection system, along with monitoring actual flows, to further evaluate whether future flow equalization can be achieved and whether recommended improvements at the WWTP will all be triggered within the planning period.

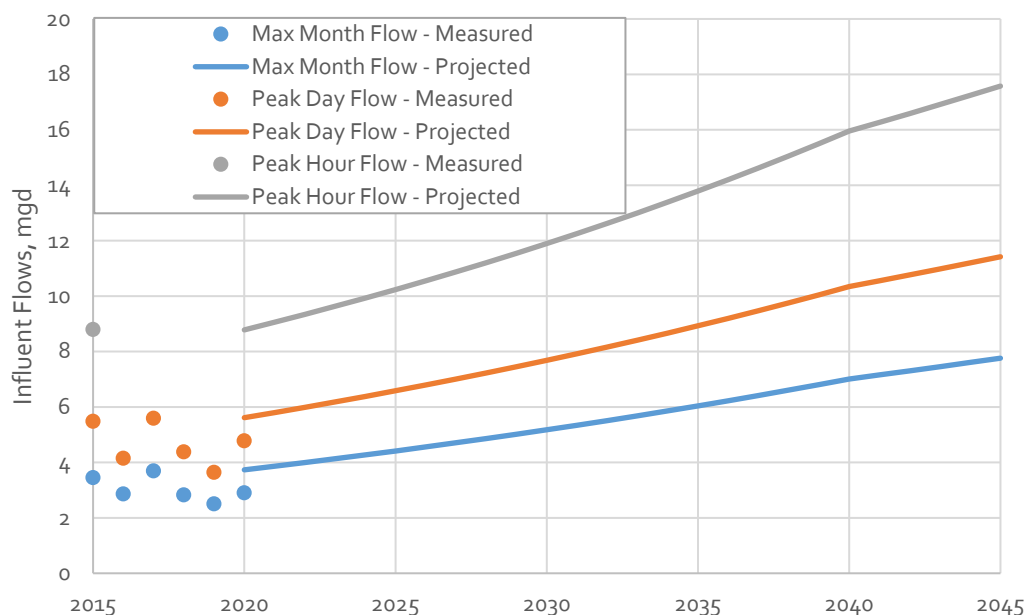

Figure ES.3 Flow Projection Summary

Load projections were calculated for influent TSS, BOD₅, NH₃, and TP. Figure ES.4 summarizes the measured and projected influent maximum month BOD and TSS loads. The projections for the remaining load elements can be found in Chapter 3.

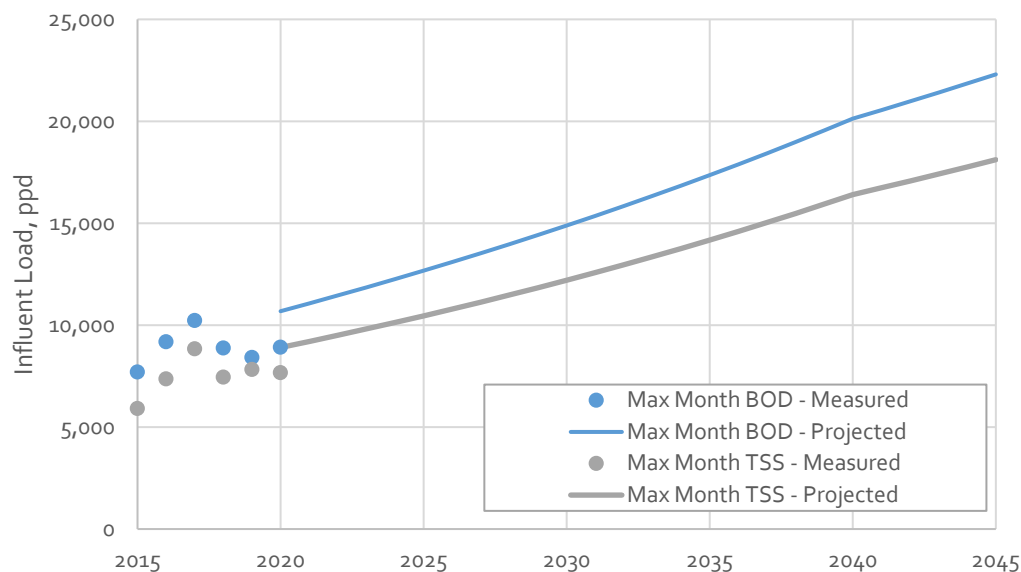

Figure ES.4 Load Projection Summary

The projected flows and loads developed in Chapter 3 were compared against the rated capacity for each of the WWTP's unit processes to determine whether expansion would be required within the planning period. The findings of this capacity analysis are discussed in the next section.

ES.5 Capacity Analysis

Summaries of plant process area capacity assessments and conclusions are presented in this Plan. These assessments focus on the need for improvements or upgrades to existing facilities to address capacity deficiencies identified in the course of Master Plan evaluations. A site plan of the City's existing WWTP is presented in Figure ES.5.

Chapter 4 identifies existing capacity ratings and deficiencies for the liquid and solids stream treatment processes at the City's WWTP. Analyses are based on operational practices in place at the time and existing effluent limits established by the WWTP's NPDES permit. Biological process modeling was performed using BioWin version 6.2 to predict plant performance under current and future flow and loading conditions to assess when unit process capacities may be exceeded within the planning period (present through 2045).

A summary of the capacity assessment completed using growth projections described in Section ES.1 is detailed below in Table ES.2. Chapter 4 presents the methodology and findings in greater detail.



LEGEND:

- 1 - DEWATERING & DRYING BUILDING
- 2 - PROCESS GALLERY
- 3 - SECONDARY CLARIFIER NO. 1
- 4 - SECONDARY CLARIFIER NO. 2
- 5 - UV DISINFECTION SYSTEM
- 6 - WORKSHOP
- 7 - SECONDARY PROCESS FACILITY
- 8 - STABILIZATION BASIN
- 9 - SLUDGE STORAGE BASINS AND BIOFILTERS
- 10 - HEADWORKS
- 11 - DISK FILTERS
- 12 - COOLING TOWERS
- 13 - W3 REUSE PUMP STATION
- 14 - OPERATIONS BUILDING
- 15 - SITE ENTRANCE

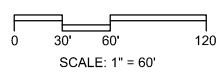

Figure ES.5
EXISTING WILSONVILLE WWTP
 CITY OF WILSONVILLE



Table ES.2 Unit Process Capacity Assessment

Unit Process	Capacity Assessment
Preliminary Treatment	
Screening	There is sufficient hydraulic capacity with both mechanical screens operational to accommodate a PHF of 17.6 mgd. Hydraulic modeling conducted by Jacobs in 2023 indicates that hydraulically the influent screening can pass the projected PHF.
Grit Removal	The 2012 WWTP Improvement documents indicate a design capacity of 16 mgd for the vortex grit basin. However, Hydraulic modeling conducted by Jacobs in 2023 indicates that hydraulically, the grit removal system can pass a PHF of 17.6 mgd. At this flow rate the anticipated performance would be poor.
Secondary Treatment	
Secondary Treatment	Based on maximum week MLSS predicted from BioWin modeling at peak day flow with all clarifiers in service (and assuming a 5-day SRT), there is only sufficient capacity through 2027. Upsized process piping is expected to be necessary to convey flow from the headworks to the secondary process and to return activated sludge within the secondary process under future flow conditions
Aeration Blowers	The air demands of the secondary treatment process are projected to exceed the firm capacity of the aeration blowers under peak conditions by 2027.
Tertiary Treatment and Disinfection	
Disk Filters	The existing disk filter capacity is expected to be exceeded by 2032 with one unit out of service or in backwash mode based on effluent limitations included in the City's DBO Contract with Jacobs. At this time the City expects to relax these contract limitations rather than invest in additional capacity.
Secondary Effluent Cooling Towers	The projected peak day flow during the months of June through September is expected to exceed the capacity of the cooling tower by the year 2036.
UV Disinfection	The existing UV channels do not have adequate capacity to disinfect the 2045 PHF with all units in service. However, the firm capacity of the UV system is sufficient to treat the PDDWF through the year 2045 with one channel out of service. The City currently has an older UV unit in place as an emergency backup to the primary system. That backup unit is aging and the City plans replacement during the planning period. By the year 2040, the UV channels are expected to exceed their hydraulic capacity.
Outfall	Even with the Willamette River at its 100-year flood elevation, it is expected that the outfall pipeline can accommodate approximately 19 mgd before the UV channel effluent weirs are at risk of submergence upstream. Since this flow is well above the hydraulic capacity of the rest of the plant, no expansion will be needed until after 2045. ⁽¹⁾ Jacobs found that under projected 2045 PHF conditions certain process and effluent piping, including piping just upstream of the Willamette River outfall and diffuser system, may be hydraulically deficient. At PHF 17.6 mgd and assuming a 0.8 mgd recycle scenario the headworks screens and grit removal systems are expected to be unsubmerged. However, upsized outfall piping between MH-B and MH-D2 is expected to be necessary to convey flow from the headworks to the secondary process under these conditions
Solids Handling	
Gravity Belt Thickener	Assuming continuous operation, the capacity analysis results indicate adequate capacity for thickening the current and projected maximum week WAS loads with one unit out of service. These units are aging and the City plans replacement during the planning period.
TWAS Storage	The TWAS storage volume is sufficient to accommodate the expected maximum week solids loads for two days (assuming TWAS is thickened to 4 percent).
Dewatering Centrifuges	The rated capacity of the current centrifuges is sufficient to process the maximum week load with one unit out of service through 2042 assuming operating times of 24 hours per day for 7 days per week, per the criteria detailed in Chapter 4. ⁽²⁾ These units will reach the end of useful life during the planning period and the City plans replacement accordingly.
Biosolids Dryer and Solids Disposal	The capacity of the biosolids dryer is adequate for handling the current and projected max week solids loads (in year 2045) on the basis of its design evaporation rate, assuming dewatered cake is dried from 20 percent TS to 92 percent TS and the dryer is operated for 24 hour per day for 7 days per week. ⁽³⁾ This unit is aging, has had recent performance issues and the City plans replacement during the planning period.

Notes:

(1) The existing outfall was recently modified and equipped with five parallel diffuser pipes equipped with duckbill check valves to improve the mixing zone characteristics in the Willamette River.

(2) The centrifuges have exhibited inconsistent performance. The City recently refurbished these units and expects they will provide sufficient capacity through 2045.

(3) The existing solids dryer has sufficient capacity through 2045 but has exhibited inconsistent performance. See Alternative 2B, Chapter 6.

Abbreviations: DBO - Design-Build-Operate; gpd/sf - gallons per day per square foot; MLSS - mixed liquor suspended solids, SPA - State Point Analysis; SRT - solids residence time; TS - total solids; TWAS - thickened waste activated sludge.

Table ES.3 further summarizes the capacity assessment by listing each unit process, associated design parameters and year of possible capacity exceedance.

Table ES.3 Unit Process Capacity Year Summary

Unit Process	Design Parameter	Redundancy Criteria	Year of Capacity Exceedance
Influent Screening	PHF	Bypass channel with manual bar rack in service and one mechanical screen out of service	>2045
Grit Chamber	PHF	All units in service	2045 ⁽¹⁾
Secondary Treatment	MW MLSS Inventory at PDF	All units in service	2027
Secondary Effluent Cooling Towers	June 1 - Sept 30 PDF	All units in service	2036
Disk Filters	MWDWF	One unit in backwash	2032 ⁽²⁾
UV Disinfection Channels	PHF	All units in service	2040 ⁽¹⁾
Outfall	PHF	-	>2045
Gravity Belt Thickening	MW Load	One unit out of service	2042
Dewatering Centrifuges	MW Load	One unit out of service	>2045 ⁽³⁾
Biosolids Dryer	MW Load	All units in service	>2045 ⁽³⁾

Notes:

- (1) The plant hydraulic modeling done as a part of the 2012 WWTP Improvements Project only evaluated plant flows as high as 16 mgd. The projected peak hour flows presented in Chapter 3 exceed this flow by the year 2045. There are some unit processes including the grit removal system, secondary clarification and UV disinfection that have a peak hydraulic capacity of 16 mgd. The hydraulic analysis conducted by Jacobs in 2023 found that under projected 2045 PHF conditions certain process and effluent piping may be hydraulically deficient. At PHF 17.6 mgd and assuming a 0.8 mgd recycle scenario the headworks screens and grit removal systems are expected to be unsubmerged. However, upsized piping is expected to be necessary to convey flow from the headworks to the secondary process under these conditions.
- (2) Existing Disk Filters are predicted to exceed reliable capacity (one unit out of service) in 2028 based on vendor provided design criteria. This conclusion assumes limitations for effluent total suspended solids contained in the WWTP DBO contract, which are far more stringent than the City's NPDES permit. At this time the City expects to relax these contract limitations rather than invest in additional capacity. Following startup of secondary treatment membrane bioreactors in 2030, the tertiary filters will be required less to meet the effluent requirements of the NPDES permit. It is anticipated the City will maintain these facilities to allow flexibility in operation to account for servicing and membrane facility downtime.
- (3) As noted previously, the existing centrifuges and biosolids dryer appear to have sufficient capacity through the planning year 2045, however condition and age are likely to require replacement during the planning period. It is recommended the City reassess available replacement technologies prior to replacement and consider loading appropriate to the planning horizon of any new units selected.

Abbreviations: MW - maximum week

ES.6 Regulatory Considerations and Strategy

It is the responsibility of the Oregon DEQ to establish and enforce water quality standards that ensure the Willamette River's beneficial uses are preserved. Discharges from wastewater treatment plants are regulated through the (NPDES. All discharges of treated wastewater to a receiving stream must comply with the conditions of an NPDES permit. The Wilsonville WWTP discharges to the Willamette River at River Mile 38.5 just upstream of the Interstate 5 bridge. The existing permit limits for the Wilsonville WWTP are shown in Table ES.4. This permit became effective on September 1, 2020 and expires July 30, 2025.

Table ES.4 Current Effluent Permit Limits

Parameter	Average Effluent Concentrations		Monthly Average, (ppd)	Weekly Average, (ppd)	Daily Maximum, (lbs)
	Monthly	Weekly			
May 1 - October 31					
CBOD ₅	10 mg/L	15 mg/L	190	280	380
TSS	10 mg/L	15 mg/L	190	280	380
November 1 - April 30					
BOD ₅	30 mg/L	45 mg/L	560	840	1100
TSS	30 mg/L	45 mg/L	560	840	1100
Other Parameters Limitations					
E. coli Bacteria	<ul style="list-style-type: none"> Shall not exceed 126 organisms per 100 ml monthly geometric mean. No single sample shall exceed 406 organisms per 100 ml. 				
pH	<ul style="list-style-type: none"> Instantaneous limit between a daily minimum of 6.0 and a daily maximum of 9.0 				
BOD ₅ Removal Efficiency	<ul style="list-style-type: none"> Shall not be less than 85% monthly average 				
TSS Removal Efficiency	<ul style="list-style-type: none"> Shall not be less than 85% monthly average 				
ETL June 1 through September 30	<ul style="list-style-type: none"> Option A: 39 million kcal/day 7-day rolling average Option B: Calculate the daily ETL limit 				

Notes:

Abbreviations: CBOD₅ - five-day carbonaceous biochemical oxygen demand; ETL - excess thermal load; kcal/day - kilocalories per day; lbs - pounds, mg/L - milligrams per liter; ml - milliliter.

The WWTP has been compliant with NPDES permit limits, generally. However due to construction issues that required that aeration basins be offline, equipment failure and issues with solids processing, the WWTP did violate their NPDES permit over eight months between 2015 and 2020 (December 2015, February 2017, April 2017, January 2018, August 2018, May 2020, June 2020 and July 2020). Most of these violations were due to the daily effluent TSS load exceeding the maximum daily load limit in the NPDES permit. It is anticipated that once the issues with solids processing are addressed, the City's current treatment process will be able to meet permit limits.

Chapter 5 details potential regulatory issues the City will need to take into consideration in coming years. Several possible regulatory actions by the Oregon DEQ could drive investments in future improvements at the City's WWTP. The plant discharges to the Willamette River and existing and future effluent limitations contained in the NPDES permit dictate, in large part, the necessary treatment processes and configuration at the WWTP necessary to maintain compliance.

Future treatment upgrades may be required when DEQ establishes total maximum daily loads (TMDL) for the lower Willamette River. Dissolved oxygen and nutrient limits, such as phosphorus limitations, are possible. The dissolved oxygen in the lower part of the river does not always meet water quality standards, and indications of excessive nutrients, such as chlorophyll-a, aquatic weeds, and harmful algal blooms, are present in the lower Willamette River. DEQ has begun its triennial review of Oregon's water quality criteria. The review could result in more stringent or new discharge requirements, but this process will take several years. For planning purposes, providing plant footprint to accommodate future treatment to remove phosphorus and address dry weather seasonal limits on dissolved oxygen should be anticipated. In addition, the City should continue to engage with DEQ regarding any proposed receiving water temperature regulatory actions keeping in mind potential limitations on effluent cooling capability provided by current cooling tower technology in operation at the WWTP.

ES.7 Alternative Development and Evaluation

Chapter 6 presents the methodology and findings of a process improvements alternatives evaluation. The plant's treatment process needs were defined by comparing the plant's existing condition, capacity and reliability, with the projected flows, loads, and regulatory constraints for the recommended alternatives. Where capacity deficiencies were predicted, at least two alternatives were analyzed for each corresponding unit process. Process modifications associated with each alternative were modeled in BioWin to evaluate the overall impact on plant operations.

As identified in Chapter 4, the secondary treatment process is expected to require additional capacity during the planning horizon (2045). Chapter 6 details two alternatives to address these capacity limitations. The two alternatives considered to increase secondary capacity are:

1. Expansion of the existing conventional activated sludge process; and
2. Intensification of the existing treatment process using membrane bioreactor (MBR) technology.

Due to the higher capital and operating costs of intensification, construction of a new conventional aeration basin is recommended as the first phase to increase secondary capacity. As flows and loads increase, or regulatory requirements become more stringent, it is expected to become necessary to intensify treatment. It is recommended the City revisit this evaluation as the need for 1) additional capacity to accommodate growth nears or 2) more stringent effluent limitations are considered. This offers the opportunity to take advantage of potential advances in technology as well as confirming the predicted time frame of capacity exceedance. A new aeration basin project is included in the Capital Improvement Plan in Chapter 7. As loads continue to increase, this plan includes the gradual conversion of the existing conventional activated sludge process to a membrane bioreactor process.

The existing aeration blower system firm capacity is expected to be deficient by 2027. An additional aeration blower (with approximately double the capacity of the current blowers) would provide for the first phase of capacity expansion. As loads continue to increase, the plan includes the gradual upsizing of the existing blowers.

The projected peak day flow between June through September is expected to exceed the capacity of the existing cooling tower. Since the existing cooling tower system was designed to be expanded with the addition of one more tower, the plan assumes the expansion of the existing cooling tower process by the year 2036 to meet the projected summer peak day flows.

Additional tertiary filtration capacity is predicted to be needed by 2032 to provide full treatment of the MWDWF with one disc filter out of service or in backwash mode. As the City has selected an intensification technology utilizing membranes, this is likely to eliminate tertiary filtration capacity concerns as the membranes replace the filtration process for TSS removal in plant effluent.

While the capacity assessment findings presented in Chapter 4 determined existing gravity belt thickeners and dewatering centrifuges have sufficient capacity assuming continuous operation, the remaining equipment service life may require replacement within the planning horizon. The centrifuges, installed in 2014, were recently refurbished, but by 2045, will have been in service for over 30 years. In addition, the gravity belt thickeners (GBT) which thicken the sludge prior to delivery to the centrifuges for dewatering, have been in service even longer. The City should plan for their replacement within the planning horizon and consider whether a capacity increase is needed at the time of replacement based on projections of solids production and processing needs. Additionally, the secondary process was modified in 2020 and has experienced extended periods where mixed liquor concentrations have been elevated above typical ranges for conventional activated sludge or extended aeration processes. Due to the complications with secondary process operation and performance issues with the centrifuges, it is recommended the City study the secondary treatment and dewatering processes to confirm that the assumptions and conclusions regarding centrifuge capacity in Chapter 4 may be relied upon. A dewatering performance optimization study is recommended so the City can collect and analyze secondary treatment and solids processing performance data. For budgeting purposes, an opinion of probable cost for replacing the existing centrifuges is presented in Chapter 7. Timing of that equipment replacement will depend on performance of the existing units, future loading assumptions, and observed condition.

The existing solids dryer has experienced operational issues in recent years, including a fire that caused extensive damage to the equipment in April 2019 and a leaking rotary joint and damaged seal in 2021. As of February 25, 2022, the dryer has been repaired and is operating. Because of the City's commitment to solids drying as the preferred process to achieve Class A biosolids, the alternatives evaluation presented in this Plan for future dryer replacement was conducted with a focus on thermal drying options only.

Chapter 6 details an analysis of the following alternatives to improve the drying system:

1. Alternative 1 - Continue operating the existing biochemical reactor (BCR) paddle dryer and defer replacement.
2. Alternative 2 - Modify the existing Dewatering and Drying Building to accommodate a different solids dryer technology or a redundant dryer.
3. Alternative 3 - Construct a new dryer building with a different solids dryer technology.

While it is anticipated the existing dryer has useful life through at least 2026 (current DBO contract expiration), by 2031 the dryer will have been in operation for over 15 years. It is recommended the planning and design of upgrades to provide reliable dryer capacity begin in 2031, or sooner if further operational concerns arise. The City has indicated a preference for a variation of Alternative 2 which involves expanding the existing Dewatering and Drying Building to accommodate a second solids paddle dryer. This alternative provides backup capacity to allow the City to continue delivering Class A solids during periods of downtime if a mechanical failure occurs or to accommodate regular maintenance of one dryer train. As mentioned previously, this Plan recommends the City complete a study of the secondary sludge quality, performance of that process, chemical addition types and locations, and solids handling process performance overall prior to making a final selection of the preferred dryer alternative from the alternatives detailed in Chapter 6. For purposes of capital planning, this Plan assumes the City will implement Alternative 2b (modification of Dewatering and Drying Building to accommodate a second paddle dryer) with a study and confirmation of this selection beginning in 2031.

Lastly, the City wants to establish a direct connection between the City's fiber optics network and the WWTP. This addition consists of routing two new conduits (one spare) and fiber optic cabling from the WWTP's Operations Building to the site entrance, where the conduits will be tied into the City's fiber optics network. Chapter 6 details one potential routing from the Operations Building to the site entrance that would minimize impact to existing yard utilities. The fiber optic cable addition is included in Chapter 7 and the City's 5-year CIP.

Table ES.5 below summarizes the alternatives evaluated in Chapter 6 including recommendations for future WWTP improvements.

Table ES.5 Summary of Alternatives

Unit Process	Alternatives Considered	Selected Alternative
Secondary Treatment	<ul style="list-style-type: none"> • Expansion of the existing conventional activated sludge process. • Intensification of the existing treatment process. 	<ul style="list-style-type: none"> • Expansion of the existing conventional activated sludge process through the addition of another aeration basin. Further phased expansion of capacity through addition of membrane bioreactor (MBR) and fine screening facilities.
Solids Dryer	<ul style="list-style-type: none"> • Continue operating the existing BCR paddle dryer and defer replacements. • Modify the existing Dewatering and Drying Building to accommodate a different solids dryer technology or a redundant dryer. • Construct a new dryer building with a different solids dryer technology. 	<ul style="list-style-type: none"> • Modify the existing Dewatering and Drying Building to accommodate a different solids dryer technology or a redundant dryer by expanding the Dewatering and Drying Building to accommodate a second solids paddle dryer.

ES.8 Recommended Alternative

Figure ES.6 presents a WWTP site plan identifying locations of recommended improvements resulting from condition and capacity assessments, including evaluation of alternatives, as described.

Summaries of opinions of probable costs and anticipated phasing for the improvements recommended for inclusion in the City's WWTP CIP are provided in Table ES.6.

The expected cash flow for the planning period was determined for the recommended improvements summarized in Table ES.6. The cash flow through 2045 includes an escalation rate of three percent, and the estimated peak expenditure for any fiscal year is approximately \$55,434,000 in fiscal year 2030. The projected CIP expenditures are presented in Figure ES.7. Capital costs estimated in the Plan will be considered as the City assesses the need to adjust sewer enterprise rates and charges in coming months. It will be important to distinguish capacity and condition (repair and replacement) driven improvements in assigning costs to existing rate payers and future users.

Table ES.6 WWTP CIP - Recommended Alternative Opinion of Probable Cost and Phasing

Plant Area	Project ⁽¹⁾	Opinion of Probable Cost ⁽²⁾	Approximate Year Online
Solids Handling	Dewatering Performance Optimization	\$150,000	2025
Communications/IT	Fiber Optic Cable Addition	\$60,000	2025
UV System	Backup UV System Improvement	\$1,705,000	2026
Support Buildings	Seismic Improvements	\$1,082,000	2026
Support Buildings	Geotechnical Foundation Mitigation	\$2,000,000	2026
Secondary Treatment	New Conventional Aeration Basin and Blower	\$10,222,000	2027 ⁽³⁾
Secondary Treatment	New Secondary Clarifier Mechanisms	\$1,775,000	2027
Secondary Treatment	New MBR, Blowers and Fine Screens (Phase 1)	\$69,727,000	2031
Solids Handling	Solids Dryer Improvement	\$17,130,000 ⁽⁷⁾	2033
Solids Handling	Existing Centrifuge and GBT Replacement	\$3,701,000 ^(4,6)	2033 ⁽⁵⁾
Cooling Towers	New Effluent Cooling Tower	\$642,000	2036
Secondary Treatment	Additional MBR and Blower Capacity (Phase 2)	\$2,330,000	2039
UV System	UV Equipment Replacement	\$2,571,000	2040
Outfall	Outfall Improvements	\$1,244,000	2040
Secondary Treatment	Additional MBR and Blower Capacity (Phase 3)	\$8,117,000	2044
TOTAL		\$122,456,000	

Notes:

White rows indicate projects that are in the City's 5-year CIP and blue rows indicate projects that are outside the 5-year CIP window.

- (1) Details of each project can be found in Chapter 2 or Chapter 6 of this Master Plan.
- (2) The estimated opinion of probable costs include the construction costs plus ELA (or soft costs). Details on the estimated project costs can be found in Chapter 2 or Chapter 6 of the plan, with the exception of costs for the backup UV system and centrifuges which are presented earlier in Chapter 7. All costs presented are based on an August 2023 ENR index of 13473.
- (3) As identified in Chapter 4, the secondary treatment process at the Wilsonville WWTP is expected to require additional capacity by the year 2027. Since design and construction of a new aeration basin may take longer than the year 2027, the City will likely need to operate at SRTs lower than 5 days during the maximum week condition if growth occurs as predicted in Chapter 3.
- (4) For budgeting purposes, the Option B centrifuge cost from Table H-2 in Appendix K is used for the project cost summary and the CIP.
- (5) Replacement timing dependent upon satisfactory equipment performance.
- (6) The centrifuges installed with the City's 2014 upgrade project have exhibited inconsistent performance in recent months. The City recently refurbished these units and expects they will provide sufficient capacity through 2042. However, by that time, the units will have been in service for over 30 years. It is recommended the City plan for replacement of these units during the planning horizon of this Master Plan. Assuming replacement occurs in the mid-2030's the City should reassess capacity needs of those units beyond the 2045 horizon, consistent with the expected service life of the new equipment.
- (7) The existing solids dryer has sufficient capacity through 2045. As with the dewatering centrifuges, the dryer equipment will soon have been in operation for a decade. It is recommended the City plan for replacement of the dryer during the planning horizon of this Master Plan. The City plans to replace the existing dryer with a new piece of equipment using similar technology and potentially rehabilitate the existing unit to serve as a backup. See Alternative 2B, Chapter 6.

The years in which key processes are projected to exceed capacity are presented in Figure ES.8. The green line illustrates projected MM BOD triggers for existing and proposed new secondary treatment facilities. Projected PHF is shown in blue indicating capacity exceedance of the cooling tower and certain elements of plant hydraulics. Prior to the year of projected exceedance, planning, design, and construction activities will be required to allow upgrades to be commissioned to prevent capacity exceedances. It is important to note that the timing of improvements should be driven by the rate of growth in influent flow and load. Dates indicated in Figure ES.8 and elsewhere in this document should be considered best, conservative estimates based on projections presented herein and professional judgement.

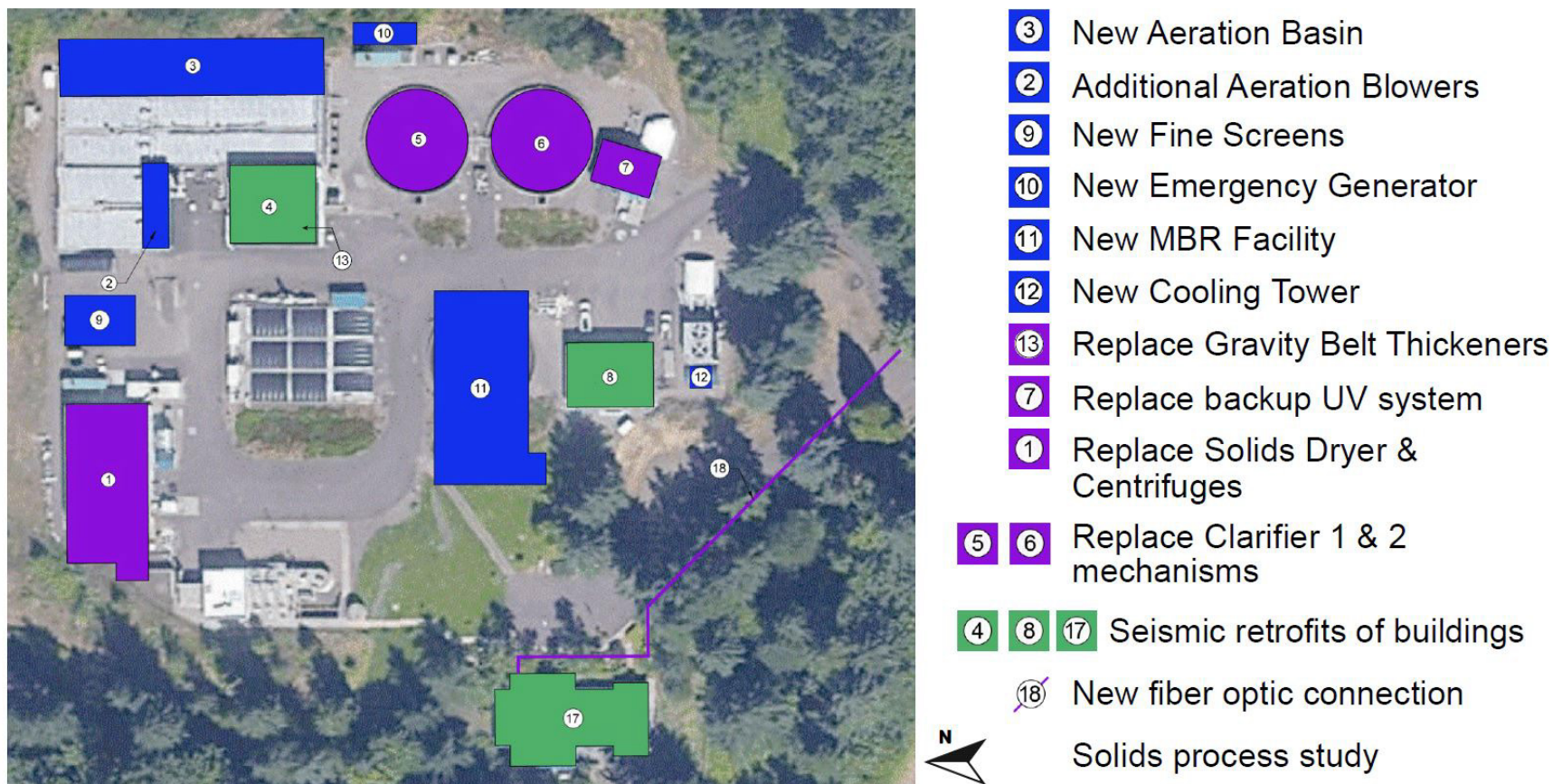

Figure ES.6 Proposed WWTP Improvements Site Plan

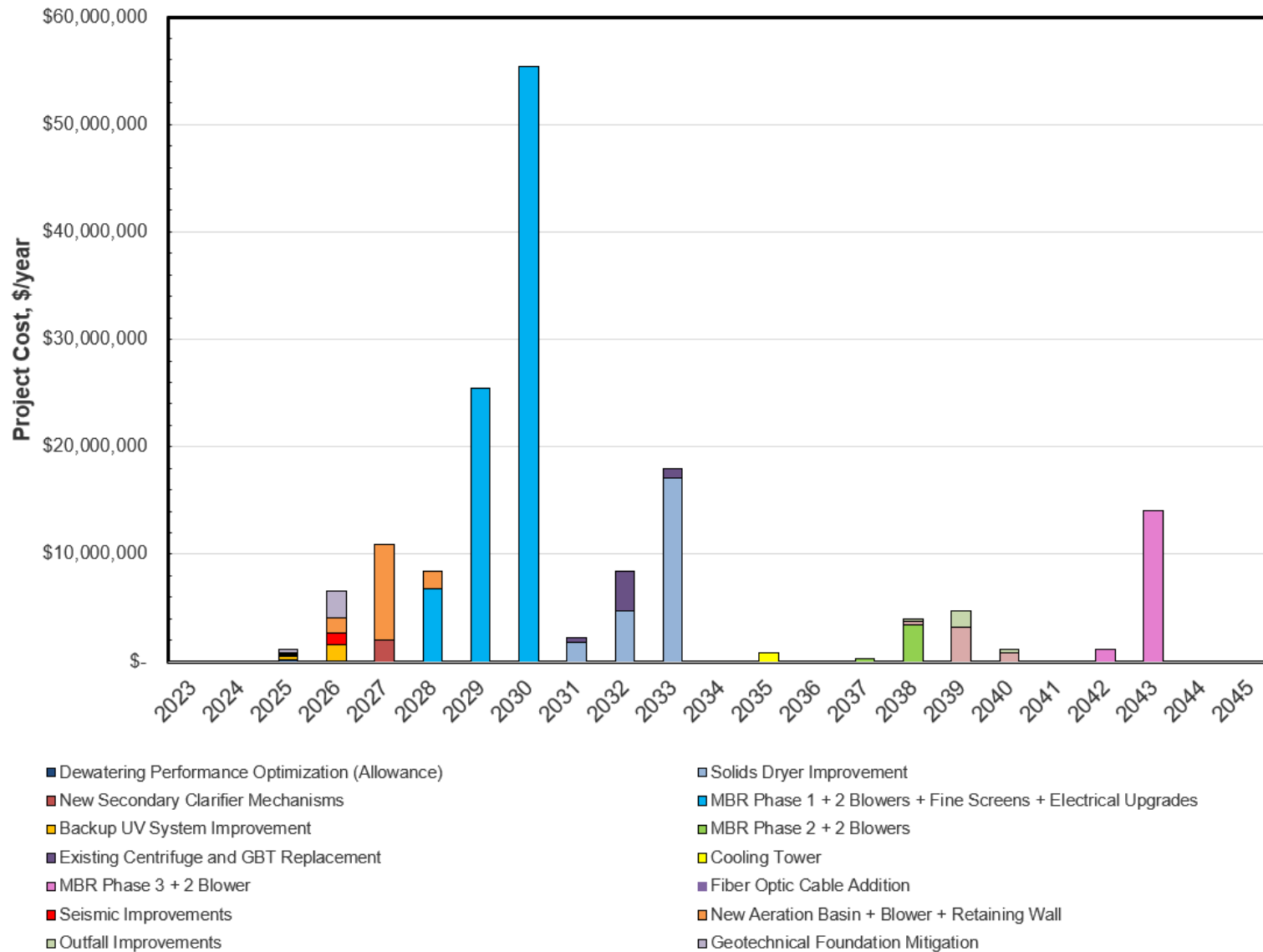

Figure ES.7 Projected 20-Year CIP Expenditures

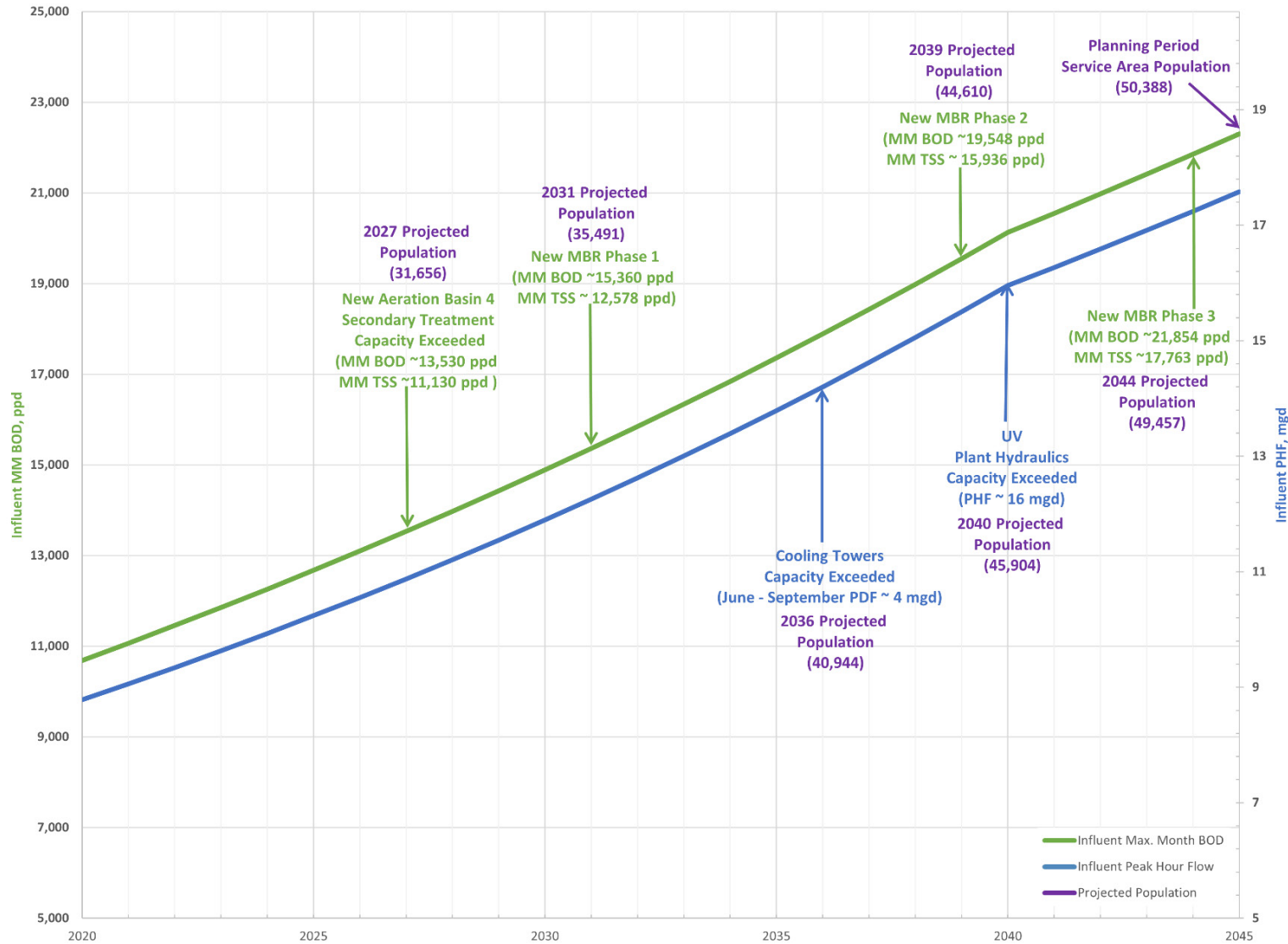

Figure ES.8 Capacity Trigger Graph



Chapter 1

PLANNING AREA CHARACTERISTICS

1.1 Introduction

The City of Wilsonville (City) is preparing a master plan (Plan) for its Wastewater Treatment Plant (WWTP). The goal of this Plan is to develop a 20-year capital plan that identifies improvements to the City's WWTP. These recommended improvements were selected to provide the best value to the City's ratepayers by maximizing the use of existing infrastructure and optimizing system operation while protecting water quality and human health and supporting economic development.

This chapter documents City wastewater service area characteristics relevant to planning facility improvements. These characteristics are summarized in a manner consistent with the City's approach to planning and operating its conveyance and treatment facilities, and in accordance with requirements for wastewater planning documents set forth by the Oregon Department of Environmental Quality (DEQ) that support financing through the Clean Water State Revolving Fund (SRF). The chapter also demonstrates the City's compatibility with the local governmental comprehensive plan and Statewide Land Use Goal 11 (Goal 11) and describes how Oregon's Integrated Water Resources Strategy (IWRs) were considered as part of the overall planning strategy.

1.1.1 Background

The City's existing system collects wastewater from residences, businesses, industries, and public facilities and conveys the flow to the City's WWTP. The most recent master plan, Wastewater Collection System Master Plan (Murray, Smith & Associates, Inc., 2014) considered areas within the existing City Limits, the Oregon Metro (Metro) identified Urban Growth Boundary and the Urban Reserve Areas to develop wastewater flow projections. These flows inform the collection system capacity needed to effectively convey flow to the WWTP as well as capacity required at the plant to properly treat and discharge wastewater in accordance with permit limitations.

The City's existing WWTP was constructed in the early 1970s, with upgrades completed in the 80s and 90s. To accommodate growth and effluent water quality requirements, the City completed a major upgrade in 2014. The current WWTP includes a headworks unit with screening and grit removal, three aeration basins, two stabilization basins, three circular secondary clarifiers, two disk filters, two ultraviolet (UV) disinfection channels, two centrifuges, one dryer, and five sludge storage basins. Treated and disinfected effluent is discharged to the Willamette River. Waste sludge is conditioned with polymer and thickened with gravity belt thickeners. Thickened waste sludge is dewatered in centrifuge units and dried to a Class A product. An odor control biofilter and fans draw and treat odorous air from the treatment plant.

1.1.2 Scope

This Plan identifies a 20-year schedule of capital improvements to the City's WWTP expected to accommodate growth in the area, address changing regulatory requirements, maintain existing facilities, and mitigate life safety and seismic deficiencies. Specific objectives of the Plan are addressed by individual chapters and include the following:

- Chapter 1 - Planning Area Characteristics: Defines locally adopted comprehensive land use plans, urban growth boundaries, City boundary, and sewer service plans.
- Chapter 2 - Condition Assessment and Tier 1 Seismic Analysis Summary: Reviews and summarizes recently collected condition assessment data and performs a life safety/seismic evaluation.
- Chapter 3 - Wastewater Flow and Load Projections: Develops projected flows and loads to be treated at the WWTP.
- Chapter 4 - Capacity Analysis: Determines the capacity of the existing treatment plant under current NPDES conditions.
- Chapter 5 - Regulatory Considerations and Strategy: Assesses and documents regulatory considerations for the Plan and develops an overall regulatory strategy.
- Chapter 6 - Alternative Development and Evaluation: Identifies, develops, and evaluates alternatives by process area that will maximize the use of existing assets at the WWTP and provide flexibility to meet potential future regulatory requirements.
- Chapter 7 - Recommended Alternative: Finalizes the recommended alternatives to be adopted in the Plan.

1.1.3 Reference Studies and Sources

The following sources were used to develop this Chapter:

- Portland State University Population Research Center.
- US Census Bureau American Community Surveys, City of Wilsonville, 2010-2018.
- The Oregon Conservation Strategy, Oregon Department of Fish and Wildlife, 2016.
- Metro Land Use Documentation.
- Mero Population Projections.
- Oregon DEQ Wastewater Facility Planning Guide.
- Oregon's Integrated Water Resources Strategy.
- Statewide Land Use Goal 11, 2005 Update.
- Natural Resources Conservation Service (NRCS).
- Oregon State Historic Preservation Historic Sites Database (HSD).
- Oregon Department of Geology and Mineral Industries (DOGAMI).
- Federal Emergency Management Agency (FEMA).

The following City reports, and plans were also referenced:

- City of Wilsonville Wastewater Collection System Master Plan, November 2014, Murray, Smith & Associates, Inc.
- City of Wilsonville Comprehensive Plan, October 2018.

1.2 Plan Requirements

This Plan was prepared, in part, to meet the requirements of three Oregon planning guidance documents, which are briefly described in this section.

1.2.1 Oregon DEQ Wastewater Facility Planning Guide, July 2019

The Oregon DEQ developed a Wastewater Facility Planning Guide (Guide) to help communities develop and evaluate wastewater alternatives to meet their long-term needs. The Oregon DEQ administers the SRF, which provides below-market rate loans to public agencies for preparation of planning and environmental review documents, designing and constructing wastewater facilities, and completing other water quality improvement design and construction projects.

The Guidelines for Preparing Wastewater Planning Documents and Environmental Reports for Public Utilities, last revised in July 2019, outline the required contents of a wastewater planning document.

1.2.2 Oregon's Integrated Water Resources Strategy, 2017 Update

The IWRS provides a blueprint for the state to better understand and meet its instream and out-of-stream water needs relative to water quantity, water quality, and ecosystem needs. The IWRS also recommends actions applicable to wastewater planning.

1.2.3 Statewide Land Use Goal 11, 2005 Update

In Oregon, the foundation for the statewide program for planning is a set of 19 statewide planning goals. The objective of Goal 11 is to plan and develop a timely, orderly, and efficient arrangement of public facilities and services to serve as a framework for urban and rural development. This goal requires cities with more than 2,500 people to adopt public facility plans to guide development, specifically for sewer and water systems.

Associated planning documents must describe the boundary and show compliance with Goal 11 and consistency with the local comprehensive plan. Wastewater planning documents must also include an affirmative land use compatibility statement from the local government to demonstrate compatibility with the comprehensive plan.

1.3 Project Planning Area

This section describes the project planning area and summarizes the City's key wastewater conveyance and treatment infrastructure.

1.3.1 Service Area Definition

The planning area is consistent with the City's 2014 Collection System Master Plan and 2018 Comprehensive Plan and includes the UGB, as well as the area where the City currently provides wastewater collection service (largely defined by the City Limits) as shown in Figure 1.1.

The planning area extends to the City of Tualatin to the north and is bounded by the Willamette River to the south, apart from the Charbonneau District south of the Willamette River.

The planning area also includes portions of the urban reserve areas (URA), which have been identified by Metro and are also shown in Figure 1.1.

The City's current wastewater service area follows the City boundary, but also includes a small area just outside the City boundary at the Coffee Creek Correctional Facility. The City also provides wastewater service to the French Prairie Rest Area south of the City on I-5, as shown in Figure 1.1.

The Basalt Creek Concept Plan, adopted in 2018, resulted in a refinement of the City service area compared to assumptions applied at the time of the 2014 Wastewater Collection System Master Plan (CSMP). The Basalt Creek Concept Plan establishes the northern Wilsonville service area boundary as the future Basalt Creek Parkway roadway alignment. This decision is reflected in Figure 1.1, which shows the Study Area Boundary as analyzed in the 2014 CSMP, incorporating the Basalt Creek Concept Plan service area refinements described above. The resulting boundary shown in Figure 1.1 defines the service area for this WWTP Master Plan.

1.3.2 Existing Conveyance and Treatment Facilities

The City operates and maintains approximately 70 miles of sewer pipe, which consists of gravity pipes between 4.0- and 36 inches in diameter and 1,700 manholes. The collection system also includes nine pump stations, not including private pump stations that discharge into the City's system. The system conveys residential and non-residential wastewater to the WWTP, located at the southern end of the City adjacent to the Willamette River. The City's sanitary sewer system consists of seven primary basins that cover nearly 12 square miles in the service area. Figure 1.2 illustrates the City's existing sanitary sewer conveyance infrastructure and the location of the WWTP.

1.3.2.1 Wastewater Treatment Plant

The City's WWTP was originally commissioned in 1972 and discharges treated effluent to the Willamette River. The WWTP was upgraded in 2014 to expand the average dry weather capacity to 4.0 million gallons per day (mgd) to accommodate growth. The WWTP processes include screening and grit removal facilities, aeration basins, contact stabilization basins, secondary clarifiers, tertiary filters, effluent cooling towers, UV disinfection channels, and biosolids thickening, dewatering, and drying processes. Recent improvements include changes to the odor control system, addition of cooling towers to meet temperature regulations, and changes to biosolids handling processes. During the initial stages of developing this Plan (summer/fall 2020) the WWTP secondary treatment process was modified to allow mixed liquor recycle pumping from the final aerated zone to the first zone in each basin.

The City contracts with Jacobs for operation of the WWTP under a Design-Build-Operate (DBO) agreement.

CHAPTER 1 | WASTEWATER TREATMENT PLANT MASTER PLAN | CITY OF WILSONVILLE

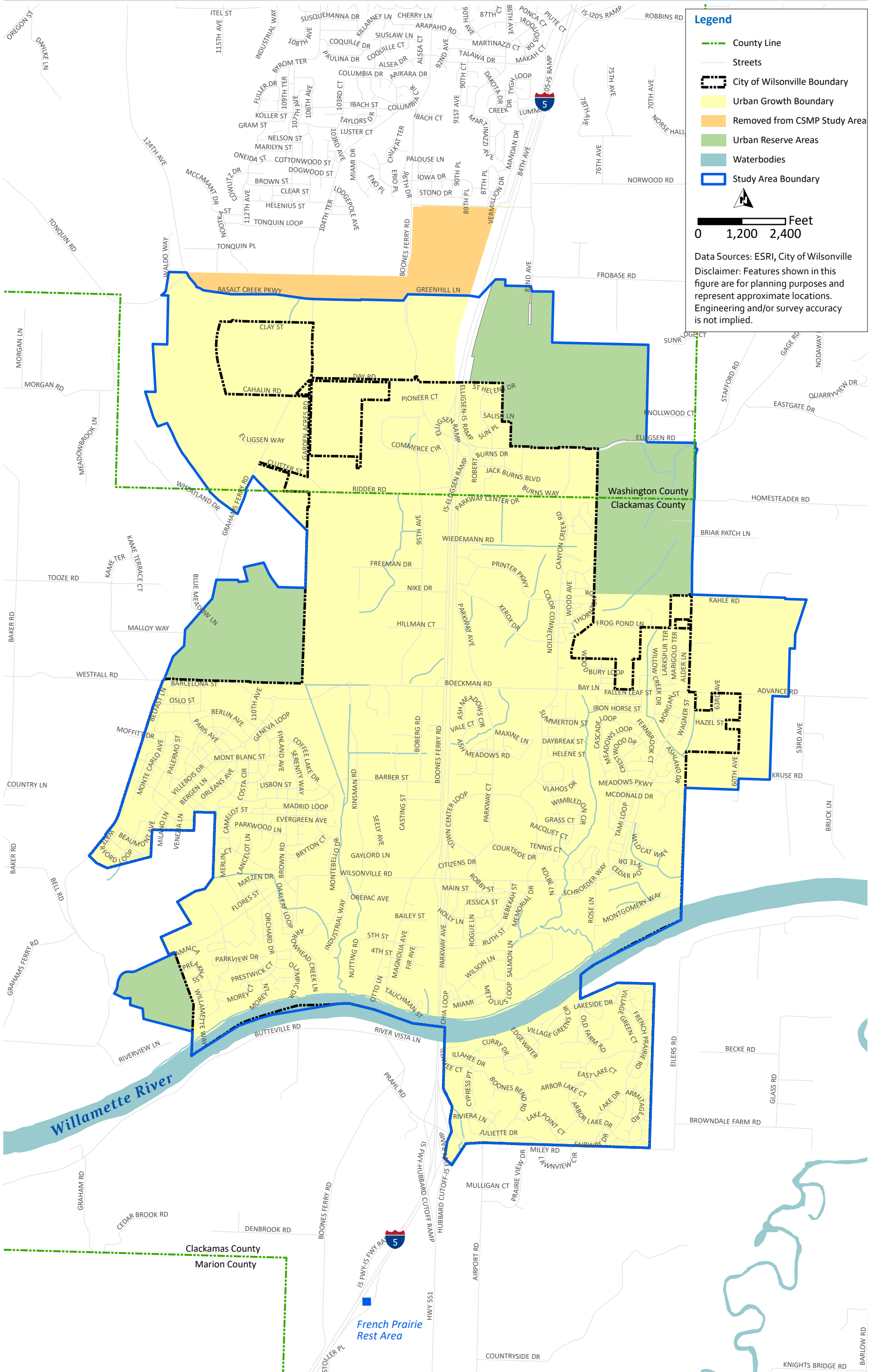

Figure 1.1 Planning Area

CHAPTER 1 | WASTEWATER TREATMENT PLANT MASTER PLAN | CITY OF WILSONVILLE

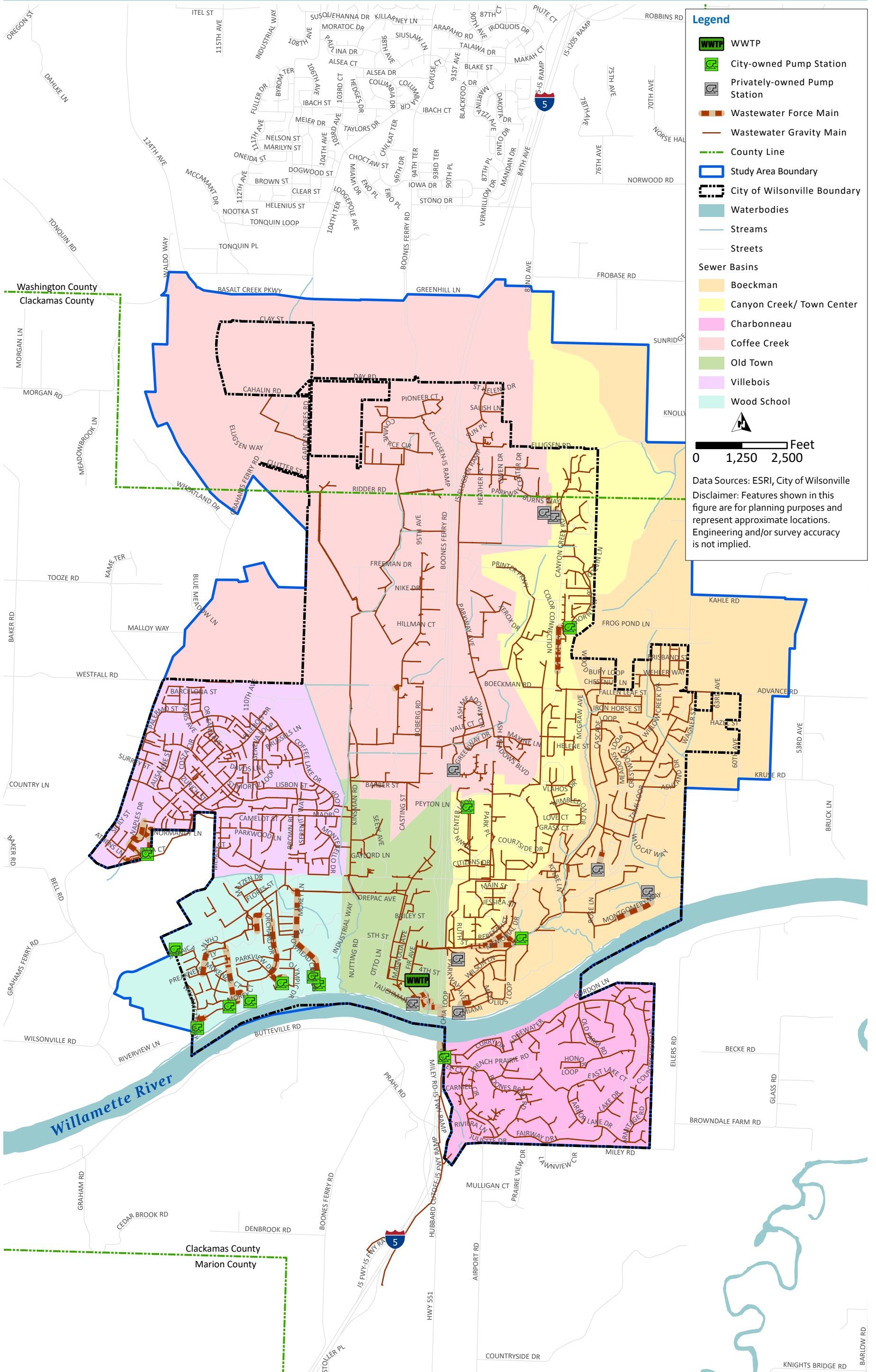

Figure 1.2 Conveyance Infrastructure and Treatment Facility

1.4 Land Use

The Statewide Goal 11: Public Facilities, Oregon Statue 197, and Oregon Administrative Rule (OAR) 660 require the following information to be included in facilities planning documents:

- An inventory and general condition assessment of all significant public facility systems supporting the land uses designed in the acknowledged comprehensive plan.
- A list of significant public facility projects that will support the land uses designated in the acknowledged comprehensive plan.
- Planning level cost estimate for each public facility project.
- A map and written description of each public facility project's general location or service area.
- Policy statements or urban growth management agreements identifying the provider of each public facility system.
- An estimate of when each facility project will be needed.
- An assessment of the provider's existing funding mechanism, their ability to fund the development of each public facility project or system, and possible new funding mechanism.

1.4.1 Locally Adopted Comprehensive Plans

The City of Wilsonville is within Metro jurisdiction. Metro serves more than 1.5 million people in Clackamas, Multnomah, and Washington counties with a boundary that encompasses Portland, Oregon and 23 other cities.

In 1992, the region's voters adopted a Charter for Metro which gave Metro jurisdiction over matters of metropolitan concern and required the adoption of a Regional Framework Plan. The Regional Framework Plan unites all of Metro's adopted land use planning policies and requirements. Under the Metro Charter and state law, cities and counties within Metro's boundaries are required to comply and be consistent with Metro's adopted Urban Growth Management Functional Plans and the Regional Framework Plan.

By state law, Metro is responsible for establishing the Portland metropolitan area's UGB, which includes Wilsonville. Land uses and densities inside the UGB are selected to support urban services such as police and fire protection, roads, schools, and water and sewer systems.

The City's Comprehensive Plan, updated most recently in 2020, reflects the land uses and UGB established by Metro. All parcels within the City have been assigned a land use designation, which includes various categories of commercial, industrial, institutional, and residential land uses. The City then assigns specific zoning within the broader land use designations.

Consistent with these requirements, Figure 1.3 shows the City's land use designations within the Plan Study Area Boundary.

1.5 Physical Characteristics

The natural environment is an important determinant of growth within a region; it contains resources which must be protected or avoided making it a key consideration in the Plan.

The northern section of the City is within Washington County, but the majority of the City is located in the northwestern part of Clackamas County. The Willamette River separates the majority of the City from the Charbonneau District, a neighborhood within the city limits south of the Willamette River.

The main thoroughfares are the Interstate-5 (I-5) freeway, which runs north-south through the City, and Boeckman Road and SW Wilsonville Road, which both run east-west through the City.

1.5.1 Climate

The City's climate has warm, dry summers, and cool, moist winters. During the wet winter season, rainfall is generally light with periods of more intense rainfall. The wettest period of the year is from November through March with the most rainfall occurring in December with an average of 6.61 inches of precipitation. July and August are the warmest months, with an average high temperature of 81-degrees Fahrenheit, and December is the coldest month, with an average low temperature of 34-degrees Fahrenheit (Source: The Weather Channel).

1.5.2 Topography

The planning area is relatively flat, except for steep slopes surrounding the natural drainage channels through the region, such as Boeckman Creek and Coffee Lake Creek. Topography ranges from 375 feet above sea level at the northern end of the study area to 60 feet above sea level at the Willamette River near the I-5 crossing. Generally, the region slopes downward towards the Willamette River. Figure 1.4 shows the topography in the planning area.

CHAPTER 1 | WASTEWATER TREATMENT PLANT MASTER PLAN | CITY OF WILSONVILLE

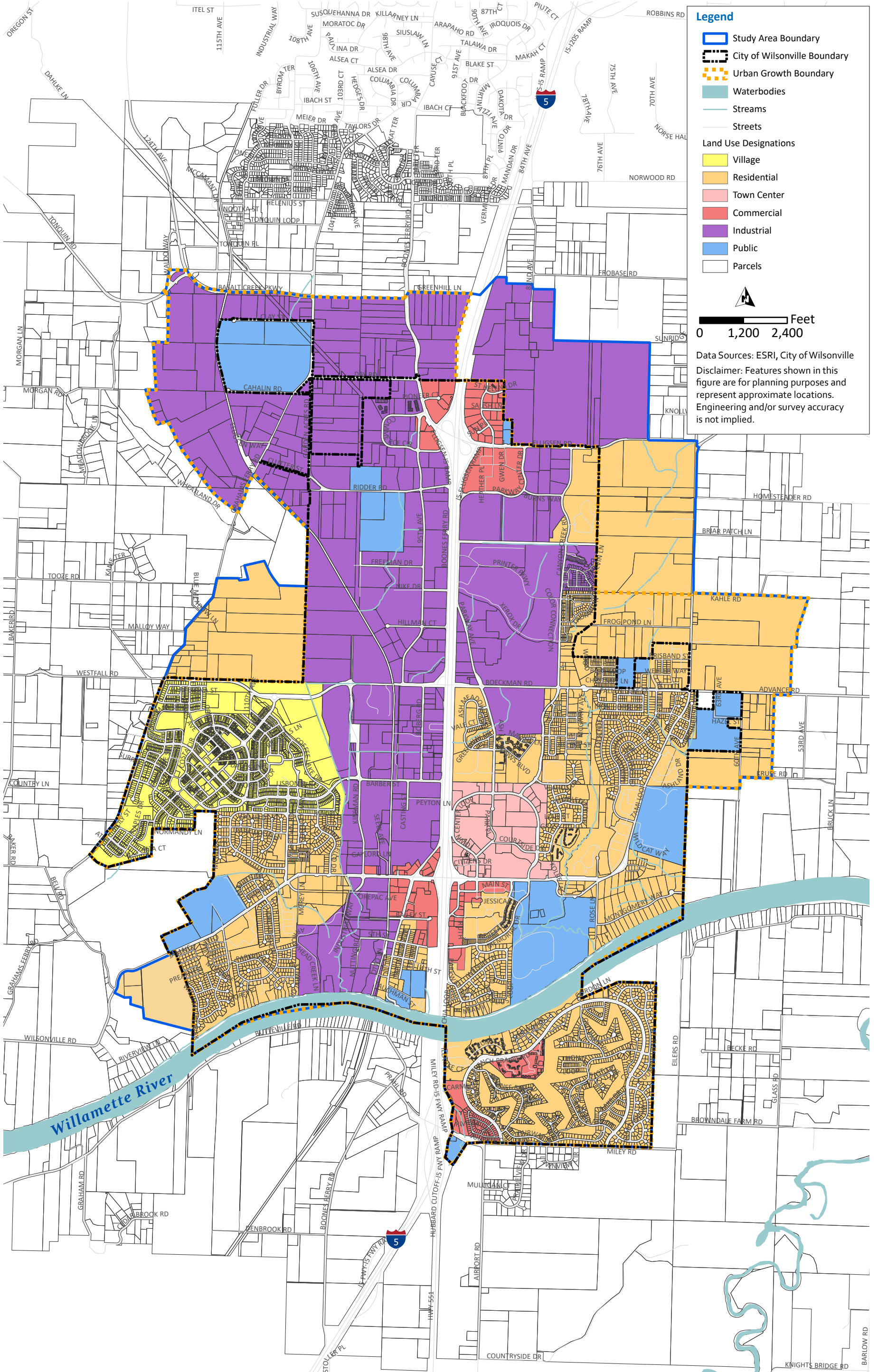

Figure 1.3 City Land Use Designations

CHAPTER 1 | WASTEWATER TREATMENT PLANT MASTER PLAN | CITY OF WILSONVILLE

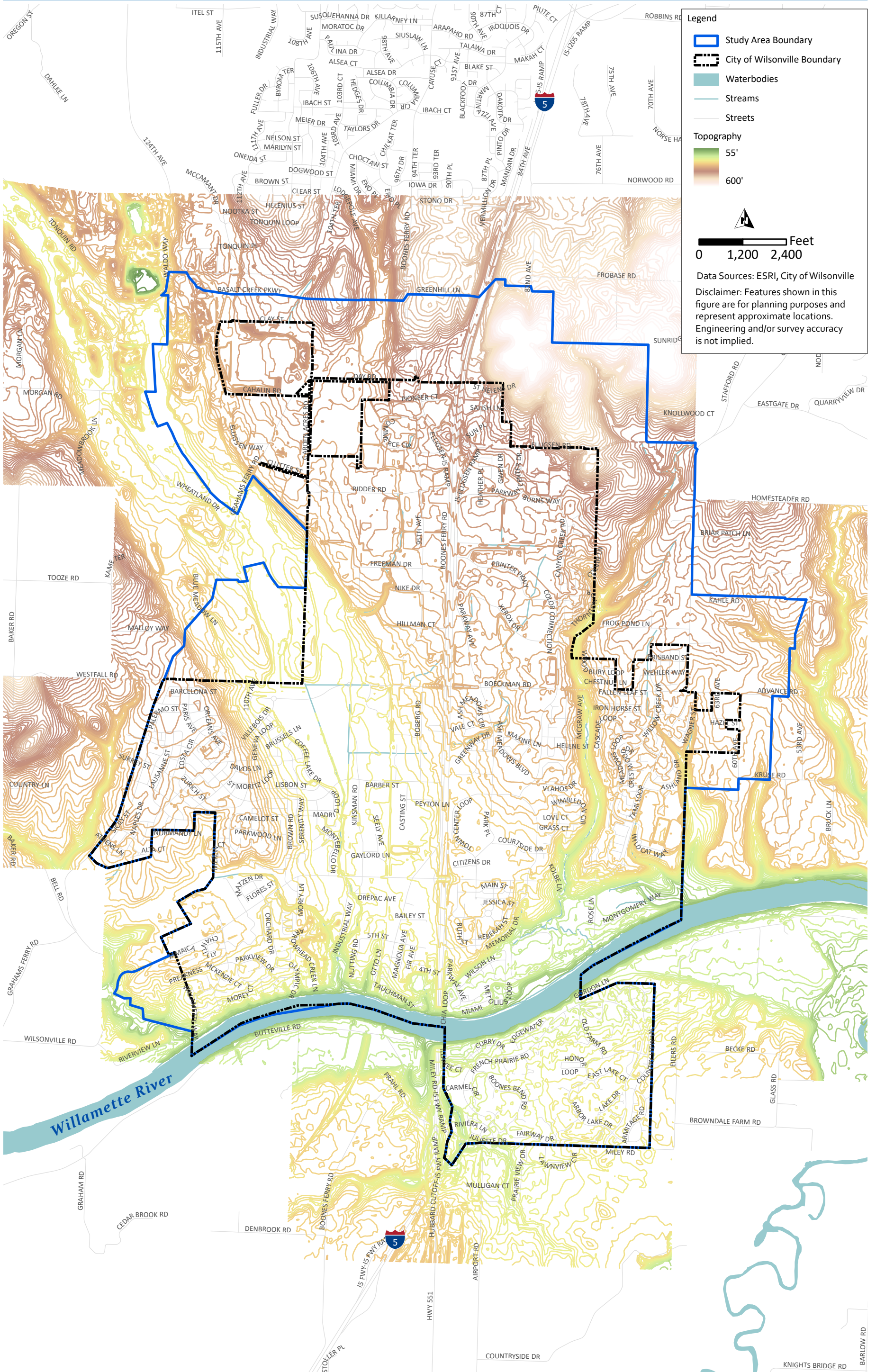

Figure 1.4 Topography

1.5.3 Geology and Soils

The geology of the City's service area is dominated by Quaternary deposits consisting of backwater deposits from the Missoula Floods as well as glaciofluvial, lacustrine, and fluvial sedimentary deposits. Higher elevations in the area are dominated by basalts from the Columbia River deposits.

The region's geologic history begins with the formation of the Columbia River Basalts (CRB) groups, which formed from millions of years of lava flows. The ancestral Columbia River and local streams carved through the CRB flows and began depositing fluvial sediments.

Over thousands of years, the Catastrophic Missoula Floods left layers of flood deposits. Local streams reestablished their courses through the flood deposits, and widespread landslide failure, many of which are still active, started occurring in canyons.

The planning area's morphology and soils were influenced significantly by the historical catastrophic flood events on the Columbia River known as the Missoula Floods. The NRCS classifies soils based on many characteristics, including hydrologic soil group, which are based on estimates of runoff potential. Table 1.1 summarizes the hydrologic soil groups, and the percentages of each soil group within the City's service area.

Table 1.1 Hydrologic Soil Groups

Group	Description	Percent of Soil in City's Service Area
Group A	Soils having a high infiltration rate (low runoff potential) when thoroughly wet. These consist mainly of deep, well drained to excessively drained sands of gravelly sands. These soils have a high rate of water transmission	1%
Group B	Soils having a moderate infiltration rate when thoroughly wet. These consist chiefly of moderately deep or deep, moderately well drained or well drained soils that have moderately fine texture to moderately coarse texture. These soils have a moderate rate of water transmission.	29%
Group C	Soils having a slow infiltration rate when thoroughly wet. These consist chiefly of soils having a layer that impedes the downward movement of water or soils of moderately fine texture of fine texture. These soils have a slow rate of water transmission.	30%
Group D	Soils having a very slow infiltration rate (high runoff potential) when thoroughly wet. These consist chiefly of clays that have a high shrink-swell potential, soils that have a high-water table, soils that have a claypan or clay later at or near the surface, and soils that are shallow over nearly impervious material. These soils have a very slow rate of water transmission.	2%

Group	Description	Percent of Soil in City's Service Area
Group C/D Dual Group ⁽¹⁾	The first letter of this grouping refers to drained condition and the second to undrained condition. The drained condition for this Dual Group is characterized by Group C soil (see description above), and the undrained condition for this Dual Group is characterized by Group D soil (see description above).	38%

Notes:

- (1) Certain wet soils are placed in Group D basely solely on the presence of a water table within 24 inches of the surface even though the saturated hydraulic conductivity may be favorable for water transmission. If these soils can be adequately drained, then they are assigned to dual hydrologic soul groups based on their saturated hydraulic conductivity and the water table depth when drained.

(Reference: <https://directives.sc.egov.usda.gov/OpenNonWebContent.aspx?content=17757.wba>)

1.5.4 Environmentally Sensitive Areas and Species

The planning area extends across the Coffee Lake Creek-Willamette River watershed (Middle Willamette). According to the Oregon Department of Fish and Wildlife (ODFW), the rivers and streams in the planning area serve as a habitat for endangered, threatened, or vulnerable native fish. Table 1.2 summarizes these species and the federal and state status of planning efforts for them.

Table 1.2 Aquatic Species Status

Species	Federal Status	State Status
Fall and spring chinook	Listed threatened	Sensitive vulnerable
Coho	Listed threatened	Sensitive vulnerable
Pacific lamprey	Species of concern	Sensitive vulnerable
Summer and winter steelhead	Listed threatened	Sensitive critical
White sturgeon	--	Data gap
Coastal cutthroat trout	Species of concern	Sensitive vulnerable

The City has identified significant natural resource areas that warrant special use management consideration to preserve water quality, visual quality, and sensitive wildlife habitats. The management and protection of these natural resource areas is implemented through the provisions of the Significant Resource Overland Zone (SROZ) ordinance.

In 2016, ODFW produced the Oregon Conservation Strategy, which serves as an overarching state strategy for conserving fish and wildlife. The Conservation Strategy identified key conservation issues that are landscape-scale threats affecting species and habitats throughout the state.

Table 1.3 summarizes the key conservation issues for the Willamette Valley Ecoregion, of which the City is a part.

Table 1.3 Key Conservation Issues of Concern in Willamette Valley Ecoregion

Conservation Issue	Description
Land Use Conversion and Urbanization	Habitat continues to be lost through conversion to other uses.
Altered Fire Regimes	Maintaining open-structured strategy habitats, such as grasslands, oak savannas, and wet prairies, partly depends on periodic burning. Fire exclusion has allowed succession to more forested habitats.
Altered Floodplain	The floodplain dynamics of the Willamette River have been significantly altered. Multiple braided channels dispersed floodwaters, deposited fertile soil, moderated water flow and temperatures, and provided a variety of slow-water habitats, such as sloughs and oxbow lakes. The Willamette River has largely been confined to a single channel and disconnected from its floodplain.
Habitat Fragmentation	Habitats for at-risk native plant and animal species are largely confined to small and often isolated fragments, such as roadsides and sloughs.
Invasive Species	Invasive plants and animals disrupt native plant and animal communities and affect populations of at-risk native species.
Wildlife Hazards	Urban landscapes can present a variety of hazards for wildlife, such as bird collisions with windows, impacts due to light pollution, predation and pet disturbance, collisions with vehicles and power lines, exposure to pesticides and contaminants, and harassment and illegal take of wildlife.

The Conservation Strategy identifies habitats of conservation concern in Oregon that provide important benefits to strategy species. These species are defined as Oregon's "species of greatest conservation need." Table 1.4 summarizes strategy habitats in the Willamette Valley Ecoregion.

Table 1.4 Strategy Habitats in the Willamette Valley Ecoregion

Type	Name
Flowing River and Riparian Habitats	Flowing water and riparian habitats include all naturally occurring flowing freshwater streams and rivers as well as the adjacent riparian habitat.
Grasslands	Grasslands in the Willamette Valley, also called upland prairies, are dominated by grasses, forbs, and wildflowers.
Natural Lakes	Natural lakes are relatively large bodies of freshwater surrounded by land. For the Conservation Strategy, they are defined as standing water bodies larger than 20 acres.
Oak Woodlands	Oak woodlands are characterized by an open canopy dominated by Oregon white oak.
Wetlands	Wetlands are covered with water for all or part of the year. Permanently wet habitats include backwater sloughs, oxbow lakes, and marshes, while seasonally wet habitats include seasonal ponds, vernal pools, and wet prairies.

1.5.5 Cultural Resources

This section lists the potential types and numbers of resources that may be encountered during construction of projects identified in this Plan. If during formal Oregon State Environmental Review Process (SERP) review further built environment resources, archaeological, or other historic resources are observed, they will be documented at a level appropriate for assessing them as potential historic properties. An inadvertent discovery plan should be established prior to implementing projects that have the potential to impact cultural resources.

Cultural Resource review includes assessing direct effects to any potential archaeological resources related to project activities, as well as assessing any indirect impacts to historic properties listed in, or eligible for, inclusion in the NRHP that would result from the project and that are within a 0.5-mile radius study area.

Review of Oregon State HSD shows there are historic districts, buildings, and structures within the City of Wilsonville. Based on the review of the HSD, there are no historic objects or sites within the City of Wilsonville.

1.5.6 Regional Hazards

Natural hazards that may occur in the planning area include earthquakes, floods, and landslides. The City is within the active area of the Cascadia Seismic Zone (CSZ), which can cause a magnitude 9.0+ earthquake. According to the Oregon Department of Geology and Mineral Industries (DOGAMI), a CSZ earthquake could produce very strong to severe shaking in the City.

Flood hazards exist along the Willamette River in the City's service area. If flooding occurs in the Willamette River, as well as Coffee Lake Creek or Boeckman Creek, extensive damage could be caused. Metro documented areas along these rivers and creeks that the FEMA designated as 100-year floodplains.

Landslide hazards exist on steeper slopes within the City. According to DOGAMI, landslide hazards in the City range from low (landsliding unlikely) to very high (existing landslide) as shown in Figure 1.5.

CHAPTER 1 | WASTEWATER TREATMENT PLANT MASTER PLAN | CITY OF WILSONVILLE

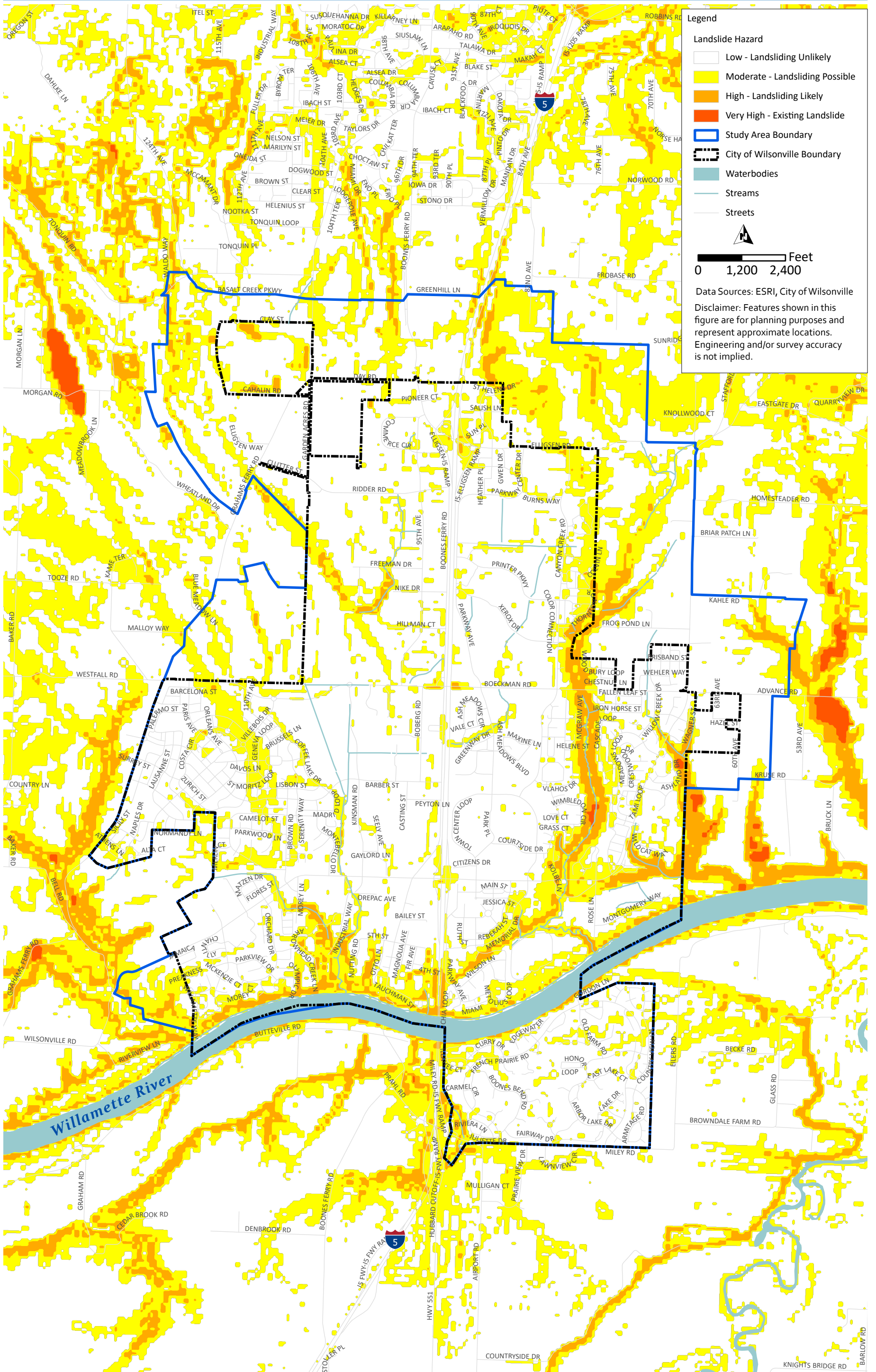

Figure 1.5 Landslide Hazards

1.5.7 WWTP Surrounding Area

As shown in Figure 1.6, the City's WWTP is located in Wilsonville north of the Willamette River just west of the I-5 crossing of that water body. The facility is bounded by I-5 to the east, residential areas to the north and west, and Boones Ferry Park to the south. The site is approximately 110 to 135 feet above sea level.

Portions of the WWTP property are within the City's SROZ, which incorporates Metro's Title 13 Habitat Conservation Areas and Habitat-Friendly Development Practices. Improvements and operations at the WWTP are consistent with the City's SROZ and Metro standards.

The dominant soils at the site include Quaternary surficial deposits, alluvial deposits, and mixed- and coarse-grained sediments. According to DOGAMI, a CSZ earthquake could produce very strong shaking at the WWTP site, and the potential landslide hazard is moderate with landsliding possible. Areas surrounding the site have a high landslide hazard with landsliding likely. Chapter 2 of this Plan presents a summary of a seismic analysis of the WWTP. The full report is included in Appendix D. A seismic response and geologic hazards assessment of the WWTP is included in Appendix E.

1.6 Water Resources

In 2012, the State of Oregon's Water Resources Commission adopted the IWRS. The goal was to bring various sectors and interests together to work toward the common goal of maintaining healthy water resources for Oregonians and the environment for generations to come.

The IWRS provides a blueprint to help the state focus its efforts on two key goals: improving the understanding of Oregon's water resources and meeting Oregon's water resources needs. The document discusses critical issues facing the state and recommends actions to address the issues. In 2017, the IWRS was updated and introduced nine new recommended actions.

Table 1.5 summarizes the IWRS-recommended actions applicable to wastewater planning.

Table 1.5 IWRS Recommended Actions for Wastewater Planning

Number	Recommended Action Description
7A	Develop and upgrade water and wastewater infrastructure.
7B	Encourage regional (sub-basin) approaches to water and wastewater systems.
9A	Undertake place-based integrated, water resources planning.
10C	Encourage additional water reuse projects.
10D	Reach environmental outcomes with non-regulatory alternatives.
12B	Reduce the use of and exposure to toxics and other pollutants.
12C	Implement water quality pollution control plans.
13C	Fund communities needing feasibility studies for water conservation, storage and reuse projects.



Figure 1.6 WWTP Vicinity Map

1.7 Population and Employment

Population and employment trends are significant factors in the planning for wastewater conveyance and treatment facilities. This section describes the trends and summarizes the projections used to determine future flows and loads as part of this Plan. Chapter 3 includes a detailed analysis of the population projections.

1.7.1 Local Industry and Significant Non-Residential Dischargers

The key industries in the City are as follows:

- Advanced manufacturing.
- Clean technology.
- Food manufacturing and distribution.
- General warehousing, distribution, and logistics.
- Medical product manufacturing and distribution.
- Software and technology.

In addition to the industries identified above, the City provides wastewater service to the Coffee Creek Correctional Facility as well.

1.7.2 Socio-Economic Trends

The US Census Bureau conducts an annual American Community Survey (ACS) to help local officials and businesses understand changes in their communities. The ACS provides data on jobs and occupations, educational attainment, and homeownership, in addition to other population trends. Table 1.6 summarizes socio-economic statistics and trends from 2010 to 2018 for the City.

According to Table 1.6, the economic trend for the City was generally positive from 2013 to 2018, with the unemployment rate steadily decreasing from 2013 to 2018. The median household income, median family income, and median nonfamily income all generally trended upwards from 2010 to 2018. The percent of people with food stamps/SNAP benefits increased between 2010 and 2016 but then began to decrease in 2017 and 2018. The percent of people without health insurance coverage steadily decreased between 2012 and 2018.

As of 2018, 96.2 percent of the population 25 years of age or older were high school graduates or had completed some education beyond high school, and 44.8 percent had received a bachelor's degree or higher.

Table 1.6 City of Wilsonville Socio-Economic Trends⁽¹⁾

Clackamas County	2010	2011	2012	2013	2014	2015	2016	2017	2018
Unemployed	4.4 %	5.5%	6.0%	6.3%	5.6%	4.5%	4.3%	3.4%	2.6%
Unemployment Rate	7.0%	8.7%	9.5%	10.0%	8.9%	7.1%	6.8%	5.3%	4.1%
Median Household Income	\$55,881	\$55,316	\$55,443	\$56,430	\$58,757	\$60,672	\$63,097	\$67,694	\$69,043
Median Family Income	\$75,027	\$76,597	\$77,757	\$75,904	\$80,955	\$76,802	\$76,201	\$79,238	\$83,935
Median Nonfamily Income	\$34,862	\$35,593	\$36,215	\$37,939	\$39,583	\$42,756	\$42,938	\$46,332	\$52,079
With Food Stamp/SNAP Benefits in Past 12 Months	7.2%	6.8%	7.9%	9.5%	9.4%	9.5%	10.4%	10.0%	8.3%
No Health Insurance Coverage (Civilian Noninstitutionalized Population)	No data	No data	16.2%	16.2%	14.6%	11.9%	9.5%	7.3%	6.5%

Notes:

(1) Source: U.S. Census Bureau American Community Surveys (<https://www.census.gov/acs/www/data/data-tables-and-tools/data-profiles/>).

Abbreviations: SNAP - Supplemental Nutrition Assistance Program.

1.7.3 Current Service Area Populations

The Portland State University Population Research Center publishes annual estimates for populations of cities, towns, and counties in Oregon. Table 1.7 summarizes recent historical population estimates for the City.

Table 1.7 Historical Population Estimates⁽¹⁾

	2016	2017	2018	2019	2020	2021	2022
City of Wilsonville	23,740	24,315	25,250	25,625	25,915	27,186	27,414

Notes:

(1) Source: Portland State University Population Research Center (Certified Estimated Populations from 2015 through 2022).

1.7.4 Population Projections

Population projections for the City are estimated by Metro. In addition to Metro population projections, the City also identifies a build-out population estimate of over 52,400 presented in their prior Water System (Keller and Assoc., 2012) and Wastewater Collection System Master Plans. An applied growth rate of 2.9 percent, along with the land use and densities outlined in the WSMP anticipate that build-out conditions may be reached in the year 2045 with a population for the study area of approximately 52,400 residents. For purposes of assessing potential demand for treatment within the City's wastewater service area (as described in section 1.3.1) and to maintain consistency with these prior plans, population projections were generated assuming a 2.9 percent rate of growth and achieving build-out conditions during the planning period (present to 2045). Note, the Water System and Wastewater Collection System Master Plan study area boundaries differ from that applied to the analysis for this WWTP Master Plan due to the 2018 Basalt Creek Concept Plan refinements discussed in section 1.3.1. As a result, the build-out population of the WWTP Master Plan Study Area is estimated to be slightly lower than projections presented in those previous plans. To align the expected build-out of the wastewater service area in 2045 with those presented in the WSMP and CSMP, along with the slight service area reduction resulting from the Basalt Creek Concept Plan, a revised growth rate of 1.9 percent was applied from 2040 to 2045. Table 1.8 summarizes the population projections for build-out of the City's wastewater service area.

Table 1.8 Summary of Build-out Population Projections⁽¹⁾

	2020	2030	2040	2045
City of Wilsonville	25,915 ⁽²⁾	34,491	45,904	50,388

Notes:

(1) A growth rate of 2.9% is applied from 2020-2040 for population projections. A revised growth rate of 1.9% is applied from 2040-2045 to accommodate the 2018 Basalt Creek Concept Plan refinements to the service area.

(2) Actual PRC data for 2020.

The build-out population is used in conjunction with assumptions about development of non-residential land uses within the service area during the planning period to project possible future flows and loads considered in this Plan. Further details are provided in Chapter 3.

Chapter 2

CONDITION ASSESSMENT AND TIER 1 SEISMIC ANALYSIS SUMMARY

2.1 Summary of Condition Assessment

In 2019, Jacobs Engineering Group Inc. (Jacobs) and Brown & Caldwell each conducted condition assessments at the City WWTP. Appendix A includes Jacobs' complete report, submitted to the City in April 2019. Brown & Caldwell's condition assessment is included in Appendix B, submitted to the City in June 2019. The City undertook an updated assessment of WWTP condition in the summer of 2023. This assessment did not identify additional condition related issues requiring significant capital outlays during the Master Plan planning period.

A total of 322 major assets (per Jacobs' report), including process and mechanical equipment (e.g., valves, gates, fans, pumps), motors and drives, control panels, generators, instrumentation, and structures, were examined for a variety of conditions that may indicate their need for maintenance or replacement. Some examples of common asset characteristics examined include corrosion; leaks; excessive vibration; unusual noise, heat, or smell during operations; and safety concerns.

For accessibility and convenience, the results of this condition assessment are summarized in a series of tables. To begin, Table 2.1 presents notable plant assets that were excluded from this condition assessment.

Table 2.1 Assets Excluded from the 2019 Condition Assessments

Asset	Description
Dryer Condensate Cooling Tower and Associated Equipment	These assets are disused since the condensate contains too much grease that fouls the cooling tower. ⁽¹⁾
Secondary Effluent Cooling Towers and Associated Equipment	These assets were not in operation at the time of the inspection. Operations staff report no issues with these assets when in use.
GBT and Associated Equipment	These assets were not in operation at the time of the inspection. ⁽²⁾
Control Panels for the Blowers	Aside from the unit that serves blower No. 4, the control panels were not fully evaluated since they were not in operation at the time of inspection. Given that they are critical to the WWTP's ability to meet its NPDES permit requirements and effectively manage biosolids, these assets must be reassessed while in operation.
Secondary Clarifier No. 3 - Spray Pump	This unit was not in operation at the time of the inspection.

Notes:

- (1) The 2020 Refurbishment project included redesign of the condensate system. Jacobs reports this is a small side stream with little influence on overall effluent temperature, and with refurbishment much cooler and not in need of cooling.
- (2) GBTs are typically used but were not in operation during the 2019 condition assessment.

Abbreviations: GBT - gravity belt thickener.

Table 2.2 presents assets that had been recently replaced or refurbished at the time of the 2019 condition assessments and, thus, currently exhibit excellent condition and performance.

Table 2.2 Assets Recently Replaced or Refurbished

Asset	Description
Aeration Basin Anaerobic Zone Mixers	These mixers were evaluated after they'd already failed and were subsequently replaced with a new large bubble mixing system as part of secondary treatment upgrades completed with the 2020 Refurbishment project. These elements (metal plates that capture and release large bubbles) are assumed to be in excellent condition.
Centrifuges	These assets were recently refurbished and observed to be in excellent condition at the time of inspection. While centrifuge performance is suboptimal at the time of this writing, this is not believed to be a condition issue.
Effluent Composite Sampler No. 1	This asset has been repaired since the completion of the condition assessment.
Biosolids Dryer, Dryer Discharge Conveyor, and Dryer Product Cooling Conveyor	All these assets were previously identified as being in extremely poor condition and requiring immediate replacement. As a result, they were all replaced, and the dryer was completely refurbished in 2020 as part of the larger WWTP Refurbishment project. However, despite this recent rehabilitation, critical components of the dryer are still subject to sudden failure, as evidenced by the recent failure of the unit rotary joint and seal, which took the unit out of service from October 2021 until early 2022.
Vactor Sump Pump	This asset's poor performance led to its recent replacement. As a result, this pump is assumed to be in current excellent condition.

Table 2.3 summarizes critical assets that require short-term rehabilitation or replacement.

Table 2.3 Critical Assets Needing Short-term Rehabilitation or Replacement

Asset	Description
Plant Drain Pumps	Pump No. 1's seal fail light was lit on at the time of inspection. Both pumps had poor insulation resistance and high amperage draw, and the pump rails showed mild deterioration.
W-3 Pumps	At the time of inspection, these pumps and their motors were running at higher-than-normal temperatures, and all had some degree of coating failure, corrosion, and leakage. Similarly, the W-3 strainer was somewhat deteriorated and corroded.
Trojan UV 4000 System	While only used as a backup to the Ozonia UV system, the Trojan system's HMI has errors that prevent it from showing the status of the lamps in module 3. Since it is used infrequently, the system's condition is largely unknown. After review of the 2019 condition assessment reports and discussion with the City and Jacobs staff, it was concluded that the UV 4000 unit must be replaced.
Secondary Clarifier No. 1 ⁽¹⁾	This clarifier's drive was excessively noisy during the inspection, and the structure showed some minor staining, corrosion, and wear. The oil seal showed moderate wear, and the weir washers were not operable at the time of inspection. Operations staff has identified replacement of the clarifier mechanism as a near-term priority. Subsequent to review of the 2019 condition assessment reports, after discussion at Recommended Plan Workshop for this Master Plan, City and Jacobs staff concluded the secondary clarifier mechanisms should be replaced within the next three years.
Secondary Clarifier No. 2 ⁽¹⁾	This clarifier structure was in similar condition as secondary clarifier No. 1, though it did not have issues with excessive drive noise. One of the weir washers was not operable at the time of inspection. The clarifier structure itself showed some concrete spalling. Operations staff has identified replacement of the clarifier mechanism as a near-term priority. Subsequent to review of the 2019 condition assessment reports, after discussion at Recommended Plan Workshop for this Master Plan, City and Jacobs staff concluded the secondary clarifier mechanisms should be replaced within the next three years.

Notes:

- (1) Ovivo completed a field review of the secondary clarifiers in April 2022. Although both units were operational, repairs were identified to improve the operation of the clarifiers. The detailed Ovivo Field Service Report is included in Appendix C.

Finally, Table 2.4 shows assets that are less critical to operations, or which reflect more minor condition issues, but which may be included in a short-term improvements project or a task order for Jacobs operations personnel.

Table 2.4 Less Critical Assets for Short-term Improvement

Asset	Description
Retractable Loadout Chute No. 3 (Biosolids Loadout Area)	This chute has failed and been left in the “up” position to facilitate trailer movement.
Odor Control Filters 20001 and 20002	These filters’ structural concrete showed minor corrosion.
Level Element 10-12100 (Headworks)	Although it functions properly, the display for this instrument does not indicate the water level.
Influent Screens No. 2 and No. 3 (Mechanical Screens)	The bar screen rake had several bent teeth in the rake assembly, preventing the rake from meshing with the bar screen.
Screenings Washer and Compactors No. 1 and No. 2	These assets show slight staining and small holes and chips in the coating. The hoses and belts were in moderate condition. Washer compactor No. 2 required maintenance at the time of evaluation.
Aeration Basin Emergency Bypass Fan 30502	The fan and motor were found to vibrate excessively, requiring extra maintenance.
Biosolids Storage Blower No. 1	This asset showed moderate belt wear and vibration issues, and some minor coating issues and bearing wear.
Centrifuge Polyblend Units	These units were leaking at the metering pump’s packing.
Plant Air Compressor No. 2	This unit shows minor seepage, wear, and corrosion.

2.2 Summary of Seismic Evaluation and Analysis

In 2021, Carollo Engineers, Inc. (Carollo) performed a seismic evaluation and analysis of the City’s WWTP. Appendix D includes Carollo’s complete report, submitted to the City in September 2021. The assessment completed prior to submittal of the November 2021 report included a desktop analysis of plant seismic and life safety risk coupled with a site visit conducted in summer 2021 by Carollo personnel. Following the site visit, Carollo presented the analysis and site visit findings to City staff in a workshop conducted in August 2021. Based on the findings shared, the City directed Carollo to perform a more detailed seismic evaluation of specific structures on the WWTP site.

Because this plant was largely upgraded and expanded in 2014, much of its infrastructure was designed in accordance with the 2010 OSSC which required design and detailing similar to current code requirements. As such, the more detailed seismic evaluation only encompassed the five older and potentially seismically vulnerable structures identified in Table 2.5. The elements of these five structures consist of reinforced concrete masonry (CMU) shear walls, cast-in-place concrete shear walls, or wood-framed shear walls with wood or metal deck roof diaphragms.

Table 2.5 List of Structures Included in Tier 2 Seismic Analysis

Structure Name	Type	Approximate Date Built
Operations Building	Building	1995
Process Gallery	Building	1995
Workshop	Building	1979
Aeration Basins and Stabilization Basins	Water-Bearing Basin	1993
Sludge Storage Basins and Biofilter	Water-Bearing Basin	1979

Performed using procedures established by American Society of Civil Engineers Standard, Seismic Evaluation and Retrofit of Existing Buildings 41-17 (ASCE 41-17), this seismic evaluation was comprised of data collection and review, a site visit, and analyses focused on ASCE 41-17's Tier 1 (Screening) and Tier 2 (Deficiency-based evaluation and retrofit) levels. Additionally, the seismic evaluation included a visual assessment of non-structural elements throughout the plant. Non-structural elements evaluated include pipe supports, light supports, and equipment anchorages to name a few.

Meanwhile, non-building structures with structural systems and load paths dissimilar to buildings (e.g., concrete tanks) were evaluated per American Concrete Institute (ACI) 350.3-06: Seismic Design of Liquid-Containing Concrete Structures and Commentary and ACI 350-06: Code Requirements for Environmental Engineering Concrete Structures.

During Tier 1 evaluations, Carollo identified potential deficiencies and needs for additional investigation. The WWTP's structures were classified as Risk Category III since they serve an important public function but their performance requirements after a seismic event are less stringent than those of a Risk Category IV structure.

Though a structure's performance level is typically evaluated against two seismic hazards, both basic safety earthquakes defined by ASCE 41-17 have lower seismic ground motions than those estimated for a magnitude 9.0 (M9.0) CSZ earthquake. Much of Oregon is currently preparing for this catastrophic natural disaster, since it is estimated there is a 35 percent likelihood of this event occurring in the Pacific Northwest within the next 50 years.

The WWTP's five structures were thus evaluated against an S-4 Limited Safety structural performance level and N-B Position Retention non-structural performance level for an M9.0 CSZ earthquake.

Following the Tier 1 evaluation and a workshop held in August 2021, Carollo moved onto Tier 2 evaluations for a select number of identified deficiencies associated with the buildings identified in Table 2.5. Though none of the structures showed significant irregularities, the team did identify the seismic deficiencies noted in Table 2.6.

Table 2.6 List of Seismic Deficiencies at the City WWTP

No.	Deficiency	Description
Operations Building		
S1	Load Path / Transfer to Shear Walls	No drag connections to transfer diaphragm forces into the shear walls where those walls are discontinuous within the plan of the building.
S2	Plan Irregularities	No diaphragm ties in the N-S direction to transfer diaphragm forces into the shear walls.
NS1	Edge Clearance	The ceiling edges lack a sufficient gap between the enclosing walls, which could cause damage via restraint.
NS2	Lens Covers	The lens covers over the lights lack safety devices.
NS3	Overhead Glazing	The windows above the entrance appear to lack proper restraint in their frame if cracked or damaged.
NS4	Tall Narrow Contents	The storage racks lack restraint to the structure. Also, the refrigerator in the laboratory appears to lack restraint if the wheels are locked.
NS5	Fall-Prone Contents / Suspended Equipment	Team could not determine if adequate lateral bracing is attached to the back of the laboratory hoods. Also, the air handler unit lacks anchorage to the structure.
Process Gallery		
S1	Load Path / Transfer To Shear Walls	The roof beam aligned with the interior shear wall lacks the ability to transfer seismic loads into the shear wall.
NS1	In-Line Equipment	The air-handling unit lacks anchorage along the channel support. Also, the aeration blower pumps in the basement lack proper anchorage to the equipment pad.
NS2	Fluid And Gas Piping	Multiple pipes lack restraint to the Unistrut support below. In addition, the compression struts for the RAS piping lack diagonal bracing back to the structure.
Workshop		
S1	Narrow Wood Shear Walls	The shear wall segments along the east elevation cannot develop overturning forces due to a lack of hold downs at the ends of each shear wall segment.
S2	Narrow Wood Shear Walls	The shear wall segments along the east elevation lack sufficient shear capacity to resist in-plane seismic loads.
S3	Narrow Wood Shear Walls	The shear wall segments along the east elevation lack adequate sill bolt anchorage to resist in-plane seismic loads.
NS1	Tall Narrow Contents	The storage racks within the building lack restraint back to the structure. In addition, the shelving unit along the south elevation lacks anchorage across the entire length.

No.	Deficiency	Description
Stabilization Basins		
S1	Freeboard	The longitudinal sloshing direction results in a freeboard deficit of approximately 1.2 feet. The aluminum covers can be damaged by sloshing water.
Sludge Storage Basins		
S1	Freeboard	The longitudinal sloshing direction results in a freeboard deficit of approximately 1.6 feet. The membrane covers can be damaged by sloshing water.
Overall Plant Structures		
NS1	Tall Narrow Contents	The storage racks within the headworks building lack anchorage back to the structure.
NS2	In-Line Equipment	The recirculation pump at the disk filters lacks restraint against overturning.
NS3	Heavy Equipment	The ACCU units near the aeration basins lack anchorage to the structural pads.

Notes:

Abbreviations: ACCU - air cooled condensing unit; RAS - return activated sludge.

These seismic deficiencies can be mitigated by performing reasonable retrofits and strengthening the existing buildings. Details of proposed mitigation measures to address seismic deficiencies identified during the Tier 2 evaluation can be found in Appendix D. Per standards established for the Association for the Advancement of Cost Engineering's (AACEI) Class 5 estimate, Carollo's recommended mitigation measures are estimated to cost \$865,100 in total construction costs with a breakdown by building presented in Table 2.7.

Table 2.7 Summary of Estimated Retrofit Cost

Description	Class 5 Estimate (2023) Accuracy Range: -50% to + 100%
Operations Building	\$688,200
Process Gallery	\$48,100
Workshop	\$122,700
Overall Plant (Non-Structural)	\$6,100
Total Estimated Construction Cost	\$865,100
Total Estimated Project Cost ⁽¹⁾	\$1,082,000

Notes:

(1) Assumes 25% Engineering, Legal, and Administrative Fees and ENR Construction Cost Index = 13473 (August 2023).

2.3 Summary of Geologic Hazards Assessment

Prior to the spring/summer 2021 seismic evaluation Carollo's subconsultant, NGI, completed a seismic response and geologic hazards assessment of the City's WWTP. Appendix E includes NGI's complete technical memorandum, which Carollo received on behalf of the City on June 25, 2021.

The City's WWTP sits on a former gravel pit located approximately 600 feet from the Willamette River. A pit-mining operation in 1953 removed a portion of the site's Missoula flood deposit (MFD) formation. Today, the plant site has the following notable geological features:

- The pit base rests at elevations of 91 feet in the north to 85 feet in the south. Gravel and pavement surfacing throughout the site ranges from elevations of 113 feet in the north to 107 feet in the south.
- Land adjacent to the pit's west side slopes north to south from 160 feet down to 135 feet. Land to the east of the site is currently being used by the Oregon Department of Transportation (ODOT) as a stockpile site for soil spoils.
- The plant site's pit backfill consists primarily of loose-to-medium-density granular soils with cobbles and boulders. Native soils below the backfill consist of the MFD composed of medium-dense sandy gravel with cobbles and boulders. The Troutdale formation rests beneath the MFD and is composed of stratified, over-consolidated hard clay and cohesive silts with inter-beds of weathered sands and gravels.

To estimate the WWTP's structural response to a full-rupture along the CSZ, NGI developed deterministic acceleration response spectra of ground motions and assessed geologic hazards and risks that may influence the City's master-planning efforts. To this end, NGI performed three geophysical survey lines across the plant site utilizing micro-tremor array measurements and multichannel analysis of surface waves.

Through past and present site investigations and engineering analyses, NGI determined that the native soils below the site's granular pit backfill pose low risks of liquefaction and its slopes revealed no obvious areas of concern. As for ODOT's spoil site, site managers were confirmed to be making concerted efforts to maintain a top-of-slope offset approximately 25 to 30 feet wide, and to incorporate an erosion containment berm so heavy rainfall does not cause the spoils to negatively affect the plant.

Additionally, NGI performed a variety of published methods to assess the potential risk of seismically induced settlement of the pit backfill. They recommended assuming one inch of seismic settlement for every 15 feet of fill anticipated to be present beneath the site and one inch of differential settlement for every 30 lateral feet.

NGI ultimately determined that the WWTP's primary site hazard is the differential settlement that may be caused by soil piping, which raises the risk of sinkholes forming beneath structures and pipelines. Soil piping typically occurs in unsaturated soils when a water source percolates into the ground. While the site is mostly paved and stormwater is actively collected, there may be numerous areas where infiltration is occurring adjacent to structures or beneath pipelines.

To mitigate the risk of soil piping, NGI recommended that the City take the following actions:

- Incorporate a stormwater evaluation and control process into the master plan program.
- Continue to capture and meter stormwater or release it off-site.
- Pave right up to structures' exterior walls.
- Include low-viscosity, cement pressure-grouting beneath key structures that have significant thicknesses of fill beneath them or foundation types more susceptible to differential settlement and loss of support.
- Retrofit pipeline entrances and exits to and from structures with a flexible section or joint to reduce the risk of pipeline failure caused by differential ground movement.
- Periodically perform drone topographic surveys of the site's eastern slope and ODOT's spoil area to monitor for spoil pile growth and potential encroachment.

Since the potential for soil piping and sinkhole development beneath structures and pipelines requires water or other fluids (including wastewater) to move soils vertically or horizontally, the control of surface water or any leakage is paramount. Paving up to structure exterior walls is intended to reduce the opportunity for infiltration of surface water or plant process overflows/leaks to cause soil piping and compromise support of portions of those structures. To further reduce risk to structural support, pressure-grouting beneath key structures located on significant depths of fill should be considered. Fill on the site is known to include significant boulders which contributes to the risk of soil piping. Flex couplings at underground pipe penetrations of structures, or flexible pipe materials in these locations may further reduce the risk of pipe failure due to differential ground movement, but also risk of liquid leakage contributing to potential soil piping.

In spring 2023, NGI performed a visual crack survey and mapped existing cracks at accessible structure floor and foundation stem wall locations. Cracking was categorized as open or tight. In addition, general locations of prior sinkholes or repaired differential settlement were identified on a facility site map. It is anticipated this information will be used to prioritize locations where mitigation may be applied to reduce risk of soil piping.

In addition, NGI completed a 50-foot boring utilizing a sonic drilling technique near the center of the former aggregate mine to assist in determining grouting conditions, prior maximum pit depth, and fill materials present in the vicinity of secondary clarifier 3.

The NGI report summarizing the findings of this spring 2023 study is provided in Appendix F. NGI recommends new structure planning include ground improvement or deep foundation systems and structural slabs. Existing structures planned for seismic upgrade investments should also include ground improvement in the form of grouting to limit the risk of excessive settlement/loss of use of key facilities. . The City intends to further evaluate the need and extent of ground improvement for WWTP structures during preliminary design of seismic upgrades identified in this Chapter. Accordingly, an allowance for future foundation mitigation measures of \$2 million is included in the City's CIP. The City will also consider ground improvement on future projects involving new or existing structures, as appropriate.

Chapter 3

WASTEWATER FLOW AND LOAD PROJECTIONS

This chapter presents an evaluation of historical wastewater flows and loads generated in the City service area along with flow and load projections through buildout.

3.1 Planning Basis

This section summarizes the service area, residential population, non-residential contribution, and rainfall records used in the analysis.

The following definitions are used throughout the memorandum:

- **Wet Season:** November 1 through April 30.
- **Dry Season:** May 1 through October 31.
- **Base Season:** July and August, when precipitation and groundwater levels are at annual lows.
- **1-in-5 year 24-hour Storm:** a 24-hour storm event that has a 20 percent probability of occurring in any given year.
- **1-in-10 year 24-hour Storm:** a 24-hour storm event that has a 10 percent probability of occurring in any given year.

This section summarizes the current and future population used throughout this chapter and the precipitation data used in estimating flows.

3.1.1 Current and Future Population

Current and future population information for the City of Wilsonville was pulled from four different sources:

- **United States Census:** US census population estimates are typically viewed as the most accurate source of current population and are available in 10-year increments. The US Census population estimates for Wilsonville for 2010 and 2020 are 19,509 and 26,664, respectively which represents a 3.2 percent compounded growth rate over these 10 years.
- **Portland State University Population Research Center (PSU PRC):** PSU PRC provides certified population for the years between the US Census estimates. After each census is complete, PSU PRC revises their estimated populations to bring them in line with the US Census values. PSU PRC revised population data for 2010 through 2020 was not available at the time this document was prepared. Because of this, the original PSU PRC population data from 2015 to 2020 was used to estimate per capita flows and loads. The PSU PRC population estimate for 2020 is 25,915 which is 3 percent less than the US Census value for 2020.
- **Metro:** Metro is the regional government for the Portland Metropolitan area and provides population projections for the City of Wilsonville. Metro produces projections of households by Transportation Analysis Zone (TAZ). The City overlaid those TAZs

onto the City's wastewater service area and found those projections to be consistent with population projections that serve as the basis for recent water system and wastewater collection system master planning documents. Those prior planning efforts are described in the bullet which follows.

- **Collection System Master Plan (CSMP) (2014, MSA) / Water System Mater Plan (WSMP) (2003, Keller Associates)**: The 2003 WSMP estimated the buildout population to be 52,400 based on anticipated land use, dwelling units per acre and people per household. They also assumed a 2.9 percent compounded growth rate which was in line with the growth in households between 2000 and 2010 based on the US Census data. (Page 2-4, WSMP). The CSMP used this same buildout population assumption along with the assumed growth rate (Page 5-2, CSMP) and estimated that buildout would occur between the years 2044 and 2045.

Since the 2014 CSMP was published, the City service area boundary upon which 2045 Urban Growth Boundary (UGB) build-out projections were based, has been altered slightly to account for Wilsonville service area refinements resulting from the Basalt Creek Conceptual Plan, as discussed in Chapter 1 of this Plan. The population for this portion of the UGB that will no longer be served by the City was estimated applying the following methodology:

- Area of the UGB expected to be annexed to the City of Tualatin = 180.1 acres.
 - Estimated area removed from residential growth = 83.2 acres.
 - Estimated area removed from commercial growth = 43.7 acres.
 - Estimated area removed from industrial growth = 53.2 acres.
- Buildable area reduction for undeveloped parcels = 65 percent (Page 5-13, CSMP 2014).
- Dwelling units per acre = 15 (Table 5-10 – "High Density", CSMP 2014).
- People per household = 2.48 (Page 5-1 and 5-13, CSMP 2014).
- Population estimated within the Basalt Creek area = 83.2 acres x 0.65 x 15 dwelling units/acre x 2.48 people dwelling unit = 2012.
- Revised 2045 population for Wilsonville: 52,400 – 2012 = 50,388.
- Population growth rate (2020-2040): 2.9 percent (Page 5-2. CSMP, 2014).
- Revised population growth rate (2040-2045): A lower revised population growth rate of 1.9 percent was assumed for the years 2040 through 2045. This growth rate was selected so that the buildout projected population would occur in the year 2045 consistent with the assumptions for the buildout year with the CSMP.

The historical per capita flow and loads presented later in this Chapter are based on the PSU PRC certified population estimates while future flow and load projections are based on the CSMP estimates to maintain consistency with prior water and sewer enterprise planning (with the slight modification to exclude the portion of the Basalt Creek Planning Area (BCPA) mentioned above). Figure 3.1 details the current population along with the historical population and growth expected for the City using the CSMP projections along with the modification to the CSMP projection discussed above. As is shown in Figure 3.1, the WSMP (2003) assumption of a 2.9 percent growth rate lines up well with the PSU PRC and US census data for the years 2010 through 2022.

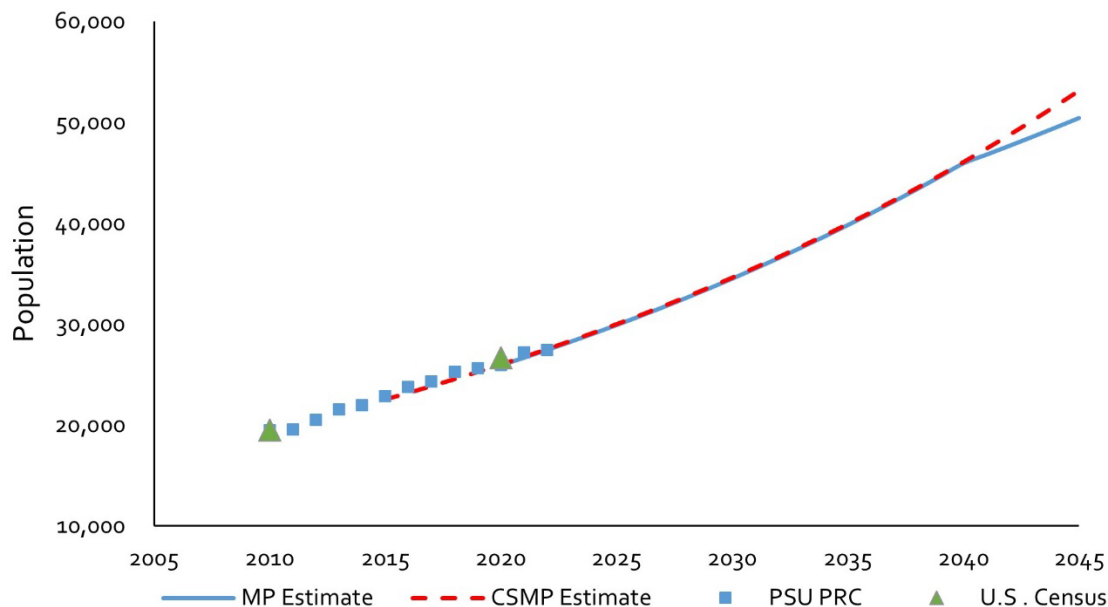

Figure 3.1 Historical Population and Expected Growth for the City of Wilsonville

3.1.2 Precipitation

The City is classified as a Marine west coast climate, which sees most of its precipitation in the winter months. During the early winter months, groundwater levels begin to elevate as precipitation increases (typically November and December). As precipitation continues from January through May, the treatment plant will experience increased influent flows as infiltration occurs throughout the collection system. Precipitation measurements are used by the Oregon DEQ methodology to predict wet weather flows. Precipitation does not typically affect biochemical oxygen demand (BOD₅) and total suspended solids (TSS) loads, though the first large storm event of the wet season will often cause high TSS loads due to the flushing of the collection system.

The National Oceanic and Atmospheric Administration (NOAA) provides daily precipitation records which can be used to determine statistical storms. For the City, the nearest gage with adequate historical data and data coverage is located at the Aurora airport (station USW00094281), approximately three miles south of the treatment facility. Figure 3.2 shows the location of the gage relative to the City's treatment facility and UGB.

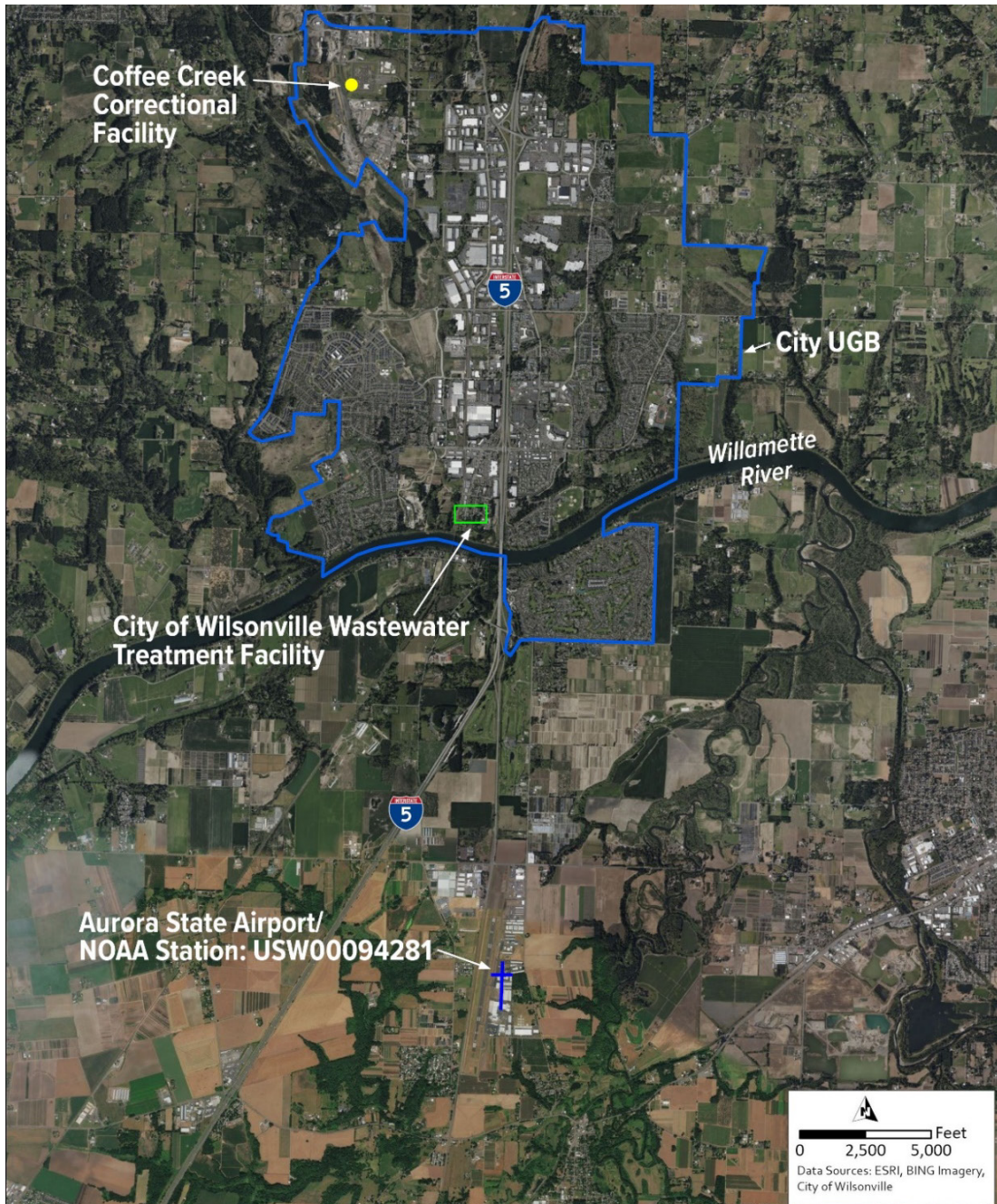

Figure 3.2 City of Wilsonville UGB

Data from January 1, 1999, through December 31, 2020, was used to create the statistical storm features found in Table 3.1. In addition to direct precipitation records, NOAA also provides isopluvial maps for these statistical storms. The NOAA maps yielded higher 1-in-5-year and 1-in-10-year 24-hour precipitation values than the direct analysis, so the larger isopluvial values were used for the DEQ flow analysis as a conservative measure.

Table 3.1 Annual Historical Rainfall Stats

Item	Value (inches)	Source
Average Annual	38.0	Aurora Airport NOAA data
Average Wet Season	28.3	Aurora Airport NOAA data
Average Dry Season	9.7	Aurora Airport NOAA data
1-in-5 year 24-hour storm	2.9	NOAA isopluvial maps
1-in-10 year 24-hour storm	3.3	NOAA isopluvial maps

Figure 3.3 below shows the average rainfall distribution by month from 1999-2020.

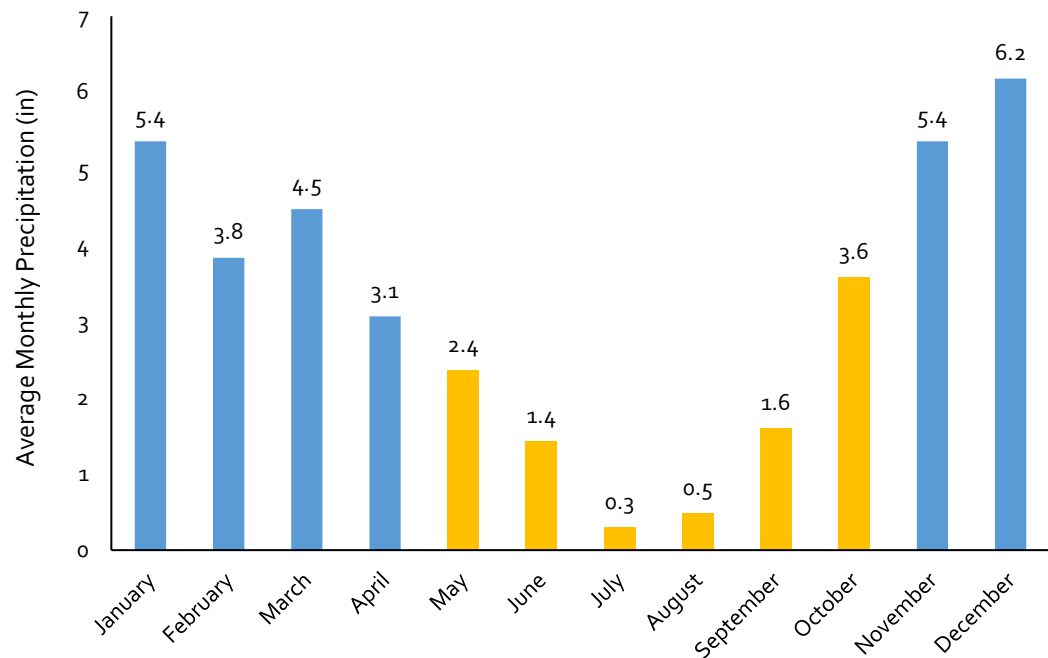

Figure 3.3 Average Monthly Rainfall at the Aurora Airport

3.2 Historical and Existing Flows

Daily monitoring reports (DMR) for the period of January 2015 – December 2020 were provided by the City. Two sets of flows will be reported in the following sections: 1) the total influent flow measured at the facility representative of all contributors in the service area and, 2) the residential/commercial (R/C) flows which represent the total influent flow less the industrial contribution.

This section summarizes the flow parameters used throughout this section, the historic industrial flow data along with the facility influent and R/C flows.

3.2.1 Flow Parameters

The flow parameters of primary interest for planning purposes are defined below. Analysis was performed considering two methods: 1) analysis of historical plant records; and 2) DEQ Guidelines for Making Wet-Weather and Peak Flow Projections for Sewage Treatment in Western Oregon, herein described as the DEQ methodology. The average dry weather flow (ADWF), average base flow (ABF), maximum week dry weather flow (MWDWF), maximum week wet weather flow (MWWWF), and peak day dry weather flow (PDDWF) were determined through the direct analysis of historical plant records as there is no defined DEQ methodology for these parameters:

- **ABF:**
 - **Direct:** The average daily flow in the months of July and August where antecedent conditions have minimal effect on influent flows. ABF flows are indicative of population contribution and used to establish peak factors.
 - **DEQ:** not applicable (N/A).
- **ADWF:**
 - **Direct:** The average of daily flows over the six-month dry weather season, May 1 through October 31.
 - **DEQ:** N/A.
- **Average Wet Weather Flow (AWWF):**
 - **Direct:** The average of daily flows over the six-month wet weather season, November 1 through April 30.
 - **DEQ:** The average flow experienced during an average wet weather precipitation period from November 1 through April 30.
- **Maximum Month Dry Weather Flow (MMDWF):**
 - **Direct:** The maximum 30-day running average flow occurring during the months of May through October.
 - **DEQ:** The monthly average flow in the rainiest dry weather month of high groundwater, typically always May, during a 1-in-10-year precipitation month.
- **Maximum Month Wet Weather Flow (MMWWF):**
 - **Direct:** The maximum 30-day running average flow occurring during the months of May through October.
 - **DEQ:** The monthly average flow in the rainiest wet weather month of high groundwater during a 1-in-5-year precipitation month.
- **MWDWF:**
 - **Direct:** The maximum 7-day running average flow occurring during the months of May through October.
 - **DEQ:** N/A.
- **MWWWF:**
 - **Direct:** The maximum 7-day running average flow occurring during the months of November through April.
 - **DEQ:** N/A.
- **PDDWF:**
 - **Direct:** The maximum daily flow from May 1 through October 31.
 - **DEQ:** N/A.

- Peak Day Wet Weather Flow (PDWWF):
 - **Direct:** The maximum daily flow from November 1 through April 30.
 - **DEQ:** The daily flow that corresponds to a 24-hour 5-year storm event. This flow will typically occur in January-April when groundwater levels are high.
- Peak Hour Flow (PHF):
 - **Direct:** The peak flow sustained for one hour.
 - **DEQ:** The peak flow determined by the following probabilities of exceedance. An underlying assumption is that all the below flow parameters occur in the same wet year:
 - The average annual flow (AAF) is exceeded 50 percent of the time.
 - The MMWWF is exceeded 8.3 percent of the time.
 - The MWWWF is exceeded 1.9 percent of the time.
 - The PDWWF is exceeded 0.27 percent of the time.
 - The PHF is exceeded 0.011 percent of the time.

3.2.2 Industrial Contribution

The City's system receives a significant contribution from permitted industrial sources. These sources are considered significant industrial users (SIU) and are regulated through the City's pre-treatment program. Data was obtained from the City's pre-treatment coordinator on the following permitted contributors:

1. **Fujimi:** Manufacturer of a variety of lapping and polishing products.
2. **Xerox:** Manufacturer of printers and other technology supplies.
3. **Swire Pacific:** Bottling plant for Coca-Cola™ products.
4. **Flir:** Tech manufacturer of thermal imaging and night vision cameras.
5. **Oregon Department of Corrections (ODOC):** Prison with a capacity of approximately 1,684 people, specifically the Coffee Creek Correctional Facility (CCCF). This prison is the only female prison in the state and is the on-boarding facility for all male prisoners.
6. **Leadtek:** Metal plating shop which, as of 2019, uses an evaporator to discharge water and no longer discharges to the City's system.
7. **Sysco:** Supplier of kitchen goods. Elevated TSS was previously measured here when truck washing occurred on site, however that operation ceased in 2019.
8. **Curran Coil Spring:** Spring manufacturer which no longer discharges to the City's system. Process water is held in a holding tank and hauled off-site.
9. **Photo Solutions:** Newly permitted user as of 2020 and a manufacturer of optical encoders.

Data was provided on a monthly-average basis, with peak values within the respective months for some users. Table 3.2 summarizes the average flows (ABF, AAF, ADWF and AWWF) and maximum month flows (MMF) for the City's SIUs between the years 2015 and 2020. For the purposes of planning, the long-term average annual flow of 0.17 mgd was selected for average flows (ABF, AAF, ADWF and AWWF). To reflect the lower maximum month flow observed in recent years, the maximum month flow over the last three years of 0.19 was selected for the MMDWF and MMWWF. Since industrial data was provided with only a monthly resolution, no data is available for the maximum weekly flows or the combined peak daily flows. The maximum month industrial flow of 0.19 was assumed to be representative of these higher peak flows as well (MWDW, MWWW, PDDW, PDWW and PHF). In addition to the permitted industrial sources, the City's collection system also includes non-permitted industrial sources. Since the flow and load from these sources is not tracked, the non-permitted industrial flow is part of the calculated residential / commercial (R/C) flow and load.

Table 3.2 Annual Average and Maximum Monthly Industrial Contributions

Year	ABF (mgd)	AAF (mgd)	ADWF (mgd)	AWWF (mgd)	MMF (mgd)
2015	0.20	0.18	0.18	0.18	0.20
2016	0.21	0.19	0.19	0.19	0.21
2017	0.18	0.18	0.18	0.18	0.18
2018	0.19	0.16	0.16	0.16	0.19
2019	0.17	0.15	0.15	0.15	0.17
2020	0.16	0.15	0.15	0.15	0.16
Average	0.19	0.17	0.17	0.17	0.20
Selected		0.17⁽¹⁾			0.19⁽²⁾

Notes:

(1) The average annual flow over the last five years was selected as the average industrial flow for all average flow conditions (ABF, AAF, ADWF and AWWF conditions).

(2) For the purposes of planning, the maximum month flow of the last three years was selected.

3.2.3 Average Flows

This section documents the current average flows (ABF, AAF, ADWF and AWWF) along with the historic and selected ABF per capita flow and the AAF, ADWF and AWWF. The selected per capita flows and peaking factors will be utilized in Section 3.3 to project future flows. The methodology used to select the ABF per capita flows, AAF, ADWF and AWWF flow peaking factors and current flows is as follows:

- **R/C ABF per capita flow:** R/C ABF per capita flows were calculated for each year between 2015 and 2020 by dividing the R/C ABF flow by the estimated population for that year. Since the City has seen a decrease in the ABF per capita flow between 2015 and 2020, the average per capita flow from the three most recent years was selected as the basis of the R/C ABF flow projections. This value was selected as it more accurately represents the City's current base flows. The selected R/C ABF was then calculated by multiplying the selected ABF per capita flow by the estimated 2020 population.
- **R/C AAF, ADWF and AWWF peaking factors:** The R/C AAF, ADWF and AWWF peaking factors were calculated for each year between 2015 and 2020 by dividing the R/C AAF, ADWF and AWWFs by the R/C ABF for that year. The average peaking factors from 2015

through 2020 were used as the basis of the R/C AAF, R/C ADWF and R/C AWWF projections. The selected R/C AAF, ADWF and AWWF were then calculated by multiplying the selected peaking factor by the selected R/C ABF discussed in the previous bullet.

- **Average industrial flows:** The average permitted industrial flow from 2015 – 2020 was selected to represent the permitted industrial contribution to the current ABF, AAF, ADWF and AWWFs. As discussed above, the non-permitted industrial contribution is part of the calculated R/C flow and load.
- **ABF, AAF, ADWF and AWWF:** The selected current facility influent ABF, AAF, ADWF and AWWFs were calculated by adding the selected industrial flow to the selected R/C flow.

3.2.3.1 Average Base Flow

The ABF was calculated to establish peak factors. From Figure 3.3, the ABF was determined to occur in July and August. These months have the lowest average precipitation and are in the middle of the dry season, when groundwater levels are not elevated, and flows are not readily influenced by storm events.

Table 3.3 summarizes the measured ABF for the years 2015 through 2020 along with the industrial and R/C components of these average flows. Between 2015 and 2020, the per capita flow ranged from 69 to 64 gallons per capita per day (gpcd). The average per capita flow for the last six years was 67 gpcd, while the average per capita flow for the last three years was 65 gpcd. To reflect the lower per capita flows observed in recent years, the average per capita flow for the last three years was selected as the basis of planning. By multiplying this per capita rate by the 2020 population, the selected R/C ABF was determined to be 1.68 mgd, which agrees well with the R/C ABFs calculated for the last three years. By adding the average industrial flow of 0.17 mgd to the selected R/C ABF, the selected ABF is calculated to be 1.85 mgd.

Table 3.3 Average Base Flow

Data Source	Population ⁽¹⁾	ABF (mgd)	Industrial (mgd)	R/C ABF ⁽²⁾ (mgd)	Per Capita (gpcd) ⁽³⁾
2015 DMRs	22,870	1.77	0.20	1.57	69
2016 DMRs	23,740	1.82	0.21	1.61	68
2017 DMRs	24,315	1.86	0.18	1.68	69
2018 DMRs	25,250	1.87	0.19	1.68	67
2019 DMRs	25,635	1.87	0.17	1.69	66
2020 DMRs	25,915	1.81	0.16 ⁽⁴⁾	1.65	64
Average Value (2015 – 2020)		1.83	0.19	1.65	67
Selected Value	25,915⁽⁵⁾	1.85⁽⁶⁾	0.17⁽⁷⁾	1.68⁽⁸⁾	65⁽⁹⁾

Notes:

- (1) Certified PSU PRC estimates.
- (2) R/C contribution = ABF - Industrial.
- (3) Calculated by dividing the R/C ABF by the population.
- (4) Data was only available through June of 2020.
- (5) 2020 population.
- (6) Selected value equals the sum of the selected industrial flow and the selected R/C ABF.
- (7) Selected average value from Table 3.2.
- (8) Calculated by multiplying the selected per capita by the selected population.
- (9) Selected equals the average value from 2018 through 2020.

3.2.3.2 Average Annual Flow

The AAF is determined as the average daily flow throughout the calendar year. Table 3.4 details the measured AAFs between the years 2015 and 2020 along with the industrial and R/C breakdown of these averages. The average R/C AAF peaking factor between 2015 and 2020 was 1.22, which was selected as the basis of projecting the AAF. By multiplying this peaking factor by the selected R/C ABF of 1.68 mgd, the selected R/C AAF is calculated to be 2.05 mgd, which agrees well with the measured historic data. By adding the average industrial flow of 0.17 mgd to the selected R/C AAF, the selected AAF is calculated to be 2.22 mgd.

Table 3.4 Average Annual Flow

Data Source	AAF (mgd)	Industrial (mgd)	R/C AAF ⁽¹⁾ (mgd)	R/C Peaking Factor ⁽²⁾
2015 DMRs	2.07	0.18	1.89	1.20
2016 DMRs	2.27	0.19	2.08	1.30
2017 DMRs	2.39	0.18	2.21	1.32
2018 DMRs	2.14	0.16	1.98	1.18
2019 DMRs	2.07	0.15	1.92	1.13
2020 DMRs	2.09	0.15 ⁽³⁾	1.95	1.18
Average Value (2015 -2020)	2.17	0.17	2.00	1.22
Selected Value	2.22⁽⁴⁾	0.17	2.05⁽⁵⁾	1.22

Notes:

- (1) R/C contribution = AAF - Industrial.
- (2) Calculated by dividing the R/C AAF by the R/C ABF from Table 3.3.
- (3) Data was only available through June of 2020. Calculated the average from January through June.
- (4) Calculated by adding the selected Industrial flow (Table 3.2) to the selected R/C AAF.
- (5) Calculated by multiplying the selected peaking factor by the selected R/C ABF from Table 3.3.

3.2.3.3 Average Dry Weather Flow

The ADWF is determined as the average daily flow during the dry season, (May through October). Table 3.5 details the measured ADWFs between the years 2015 and 2020 along with the industrial and R/C breakdown of these averages. The average R/C ADWF peaking factor between 2015 and 2020 was 1.03, which was selected as the basis for projecting the ADWF. By multiplying this peaking factor by the selected R/C ABF of 1.68 mgd, the selected R/C ADWF is calculated to be 1.74 mgd, which agrees well with the measured historic data. By adding the average industrial flow of 0.17 mgd to the selected R/C ADWF, the selected ADWF is calculated to be 1.91 mgd.

Table 3.5 Average Dry Weather Flow

Data Source	ADWF (mgd)	Industrial (mgd)	R/C ADWF ⁽¹⁾ (mgd)	R/C Peaking Factor ⁽²⁾
2015 DMRs	1.76	0.18	1.57	1.00
2016 DMRs	1.93	0.19	1.72	1.07
2017 DMRs	1.96	0.18	1.77	1.06
2018 DMRs	1.88	0.16	1.70	1.01
2019 DMRs	1.92	0.15	1.75	1.04
2020 DMRs	1.86	0.15 ⁽³⁾	1.71	1.04
Average Value (2015 – 2020)	1.88	0.17	1.70	1.03
Selected Value	1.91⁽⁴⁾	0.17	1.74⁽⁵⁾	1.03

Notes:

- (1) R/C contribution = ADWF - Industrial.
- (2) Calculated by dividing the R/C ADWF by the R/C ABF from Table 3.3.
- (3) Data was only available through June of 2020. Used the average of May through June.
- (4) Calculated by adding the selected Industrial flow (Table 3.2) to the selected R/C ADWF.
- (5) Calculated by multiplying the selected peaking factor by the selected R/C ABF from Table 3.3.

3.2.3.4 Average Wet Weather Flow

The AWWF is based on the period November through April. The AWWF was determined by both direct calculations and using DEQ methodology.

The DEQ methodology for AWWF correlates the average rainfall for each wet season with that season's precipitation. The average wet weather precipitation (28.3 inches) is fit to the trendline to calculate the DEQ AWWF, which yields an AWWF of 2.47 mgd. Figure 3.4 below illustrates the DEQ methodology applied to the City.

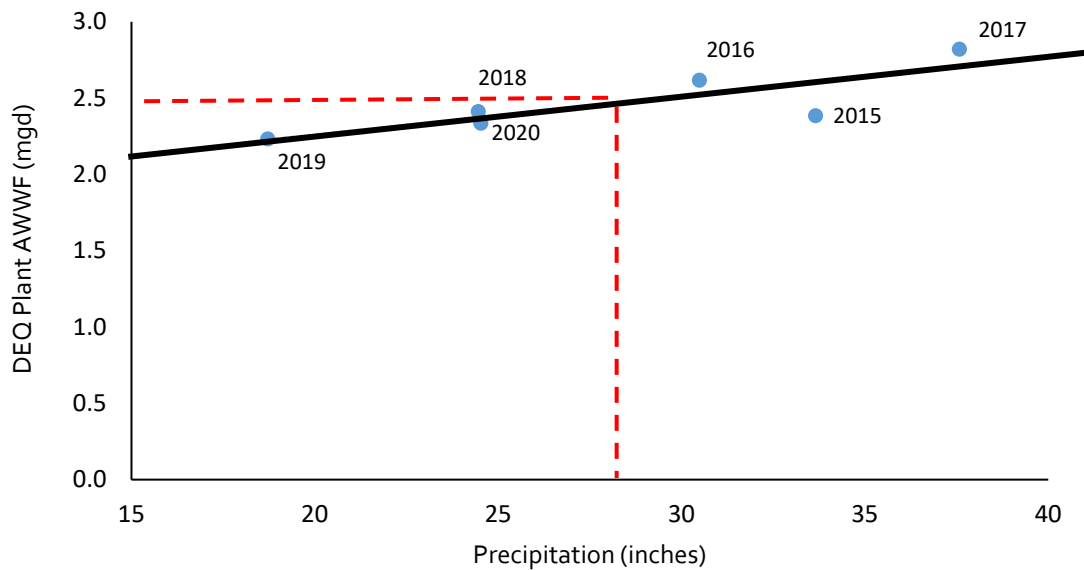

Figure 3.4 Average Wet Weather Flow DEQ Methodology

Table 3.6 details the AWWF measured for the years 2015 through 2020 along with the industrial and R/C components of these averages. The average R/C AWWF peaking factor between 2015 and 2020 was 1.40, which was selected as the basis of projecting the AWWF. By multiplying this peaking factor by the selected R/C ABF of 1.68 mgd, the selected R/C AWWF is calculated to be 2.36 mgd, which agrees well with the measured historic data. By adding the average industrial flow of 0.17 mgd to the selected R/C AWWF, the selected AWWF is calculated to be 2.53 mgd, which is slightly more conservative than the value calculated using the DEQ methodology.

Table 3.6 Average Wet Weather Flow

Data Source	AWWF (mgd)	Industrial (mgd)	R/C AWWF ⁽¹⁾ (mgd)	R/C Peaking ⁽²⁾ Factor
2015 DMRs	2.38	0.18	2.22	1.41
2016 DMRs	2.62	0.19	2.44	1.52
2017 DMRs	2.82	0.18	2.66	1.59
2018 DMRs	2.41	0.16	2.27	1.35
2019 DMRs	2.23	0.15	2.09	1.23
2020 DMRs	2.33	0.15 ⁽³⁾	2.19	1.33
DEQ Method	2.47	0.17 ⁽⁴⁾	2.30 ⁽⁵⁾	1.35 ⁽⁶⁾
Average Value (2015 – 2020)	2.47	0.17	2.31	1.40
Selected Value	2.53⁽⁷⁾	0.17	2.36⁽⁸⁾	1.40

Notes:

- (1) R/C contribution = AWWF - Industrial.
- (2) Calculated by dividing the R/C AWWF by the R/C ABF from Table 3.3.
- (3) Data was only available through June of 2020. AWWF calculated as the average of January through April.
- (4) The average industrial flow from Table 3.2 was assumed.
- (5) The R/C AWWF for the DEQ methodology was calculated by subtracting the assumed industrial flow from the DEQ methodology AWWF.
- (6) The DEQ R/C AWWF peaking factor was determined by dividing the resultant DEQ methodology R/C AWWF by the selected R/C ABF from Table 3.3.
- (7) Calculated by adding the selected Industrial flow to the selected R/C AWWF.
- (8) Calculated by multiplying the selected peaking factor by the selected R/C ABF from Table 3.3.

3.2.4 Maximum Month Flows

This section documents the historic MMDWF and MMWWF along with the historic MMDWF and MMWWF peaking factors. The selected peaking factors will be utilized in Section 3.3 to project future flows. The methodology used to calculate the current flows and peaking factors is as follows:

- **R/C MMDWF and MMWWF peaking factors:** The R/C MMDWF and MMWWF peaking factors were calculated for each year between 2015 and 2020 by dividing the R/C MMDWF and MMWWFs by the R/C ABF for that year. Additionally, R/C MMDWF and MMWWF peaking factors were calculated from the estimated MMDWF and MMWWFs utilizing the DEQ methodology by subtracting the selected industrial flows from these calculated values. DEQ methodology R/C peaking factors were then calculated by dividing the DEQ methodology R/C flows by the selected ABF. The peaking factors calculated using the DEQ methodology and the direct calculation method were compared, and the largest value was selected as basis of the R/C MMDWF and R/C MMWWF projections. The selected R/C MMDWF and R/C MMWWF were then calculated by multiplying the selected peaking factor by the selected R/C ABF discussed in the previous section.

- **MM industrial flows:** The average MM industrial flow from 2015 – 2020 was selected to represent the industrial contribution to the current MMDWF and MMWWF.
- **MMDWF and MMWWF:** The selected current facility influent MMDWF and MMWWFs were calculated by adding the selected industrial flow to the selected R/C flow.

3.2.4.1 Maximum Month Dry Weather Flow

The MMDWF was calculated by both direct and DEQ methodology. The MMDWF typically occurs in May, when groundwater levels are highest and precipitation is moderate (during the dry season), though it may occur during an exceptionally wet October as was seen in 2016 where 9.7 inches of precipitation occurred that month. Table 3.7 shows the maximum dry weather month flow for each year on record and lists the precipitation that occurred in the respective month.

Table 3.7 Direct MMDWF Calculations

Year	MMDWF (mgd)	Month	Precipitation (inches)
2015	1.8	May	1.2
2016	2.4	October	9.7
2017	2.2	May	1.8
2018	1.9	May	0.5
2019	2.0	May	1.3
2020	2.0	June	3.3

October 2016 was an exceptionally wet month. Rainfall data from 1999-2020 show that the 1-in-10-year October precipitation is 6.8 inches. Groundwater levels are typically low in October so precipitation does not have as large of an influence on flows as it would have if the large storm were to occur in May, where groundwater levels are elevated from the wet season. DEQ methodology was also employed to calculate the MMDWF and give perspective to the large flow from October 2016.

The DEQ methodology for MMDWF assumes that the precipitation from November and December serve to elevate the groundwater and saturate the soils. These soils are saturated from January through May and each storm event in that window creates a predictable response on the influent flows. A plot is created comparing the average precipitation and flows for January through May and a trendline is created. Since May is the only dry weather month where the soils can be assumed to be saturated and the groundwater elevated, the 1-in-10-year May precipitation (4.1 inches) is fit to the data to determine the MMDWF of 2.47 mgd. Figure 3.5 shows the DEQ plot to determine MMDWF.

Table 3.8 details the measured MMDWFs between the years 2015 and 2020 along with the industrial and R/C components of these values. The maximum R/C MMDWF peaking factor between 2015 and 2020 was 1.38, which was selected as the basis of planning. By multiplying this peaking factor by the selected R/C ABF of 1.68 mgd, the selected R/C MMDWF is calculated to be 2.32 mgd. The selected MMDWF of 2.51 mgd is then calculated by adding the selected maximum month industrial flow of 0.19 mgd to the selected R/C MMDWF. The selected MMDWF is approximately two percent greater than the MMDWF calculated using the DEQ methodology.

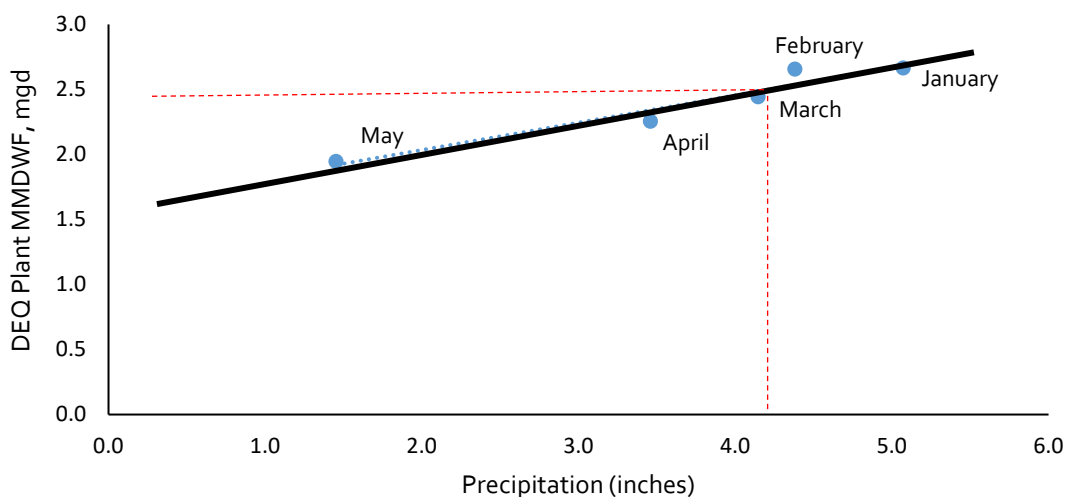

Figure 3.5 Maximum Month Dry Weather Flow DEQ Methodology

Table 3.8 Maximum Month Dry Weather Flows and Peaking Factors

Data Source	MMDWF (mgd)	Industrial ⁽¹⁾ (mgd)	R/C MMDWF ⁽²⁾ (mgd)	R/C Peaking ⁽³⁾ Factor
2015 DMRs	1.80	0.17	1.62	1.03
2016 DMRs	2.40	0.19	2.22	1.38
2017 DMRs	2.16	0.21	1.96	1.17
2018 DMRs	1.94	0.16	1.77	1.05
2019 DMRs	2.00	0.17	1.83	1.08
2020 DMRs	1.97	0.16	1.81	1.10
DEQ Method	2.47	0.19 ⁽⁴⁾	2.28 ⁽⁵⁾	1.35 ⁽⁶⁾
Maximum Value (2015 – 2020)	2.47	0.21	2.28	1.38
Selected Value	2.51⁽⁸⁾	0.19⁽⁴⁾	2.32⁽⁷⁾	1.38

Notes:

- (1) Average monthly industrial flow that occurred in the month corresponding to the influent MMDWF.
- (2) R/C = MMDWF - Industrial.
- (3) Calculated by dividing the R/C MMDWF by the R/C ABF from Table 3.3.
- (4) The maximum combined SIU MMF flow from the last three years was assumed (Table 3.2).
- (5) The R/C MMDWF for the DEQ methodology was calculated by subtracting the assumed industrial flow from the DEQ methodology MMDWF.
- (6) The DEQ R/C MMDWF peaking factor was determined by dividing the resultant DEQ methodology R/C MMDWF by the selected R/C ABF from Table 3.3.
- (7) Calculated by multiplying the selected peaking factor by the selected R/C ABF from Table 3.3.
- (8) Calculated by adding the selected Industrial flow to the selected R/C MMDWF.

3.2.4.2 Maximum Month Wet Weather Flow

The MMWWF was calculated by both direct and DEQ methodology. The MMWWF is typically expected to occur in the wettest month between January and April, where groundwater levels are highest. Table 3.9 shows the MMWWF for each year on record and lists the precipitation that occurred during the respective month.

Table 3.9 Direct MMWWF Calculations

Year	MMWWF (mgd)	Month	Precipitation (inches)
2015	3.5	December	13.7
2016	2.9	November	7.0
2017	3.7	February	10.4
2018	2.8	January	5.6
2019	2.5	February	4.0
2020	2.9	January	7.1

December of 2015 was an exceptionally wet month. Rainfall data from 1999-2020 show that the 1-in-10-year December precipitation is expected to be 10 inches. The November precipitation for 2016 is near the 1-in-5-year November from historical rainfall data, but the preceding October was very wet (9.7 inches). For both 2016 and 2015, the groundwater was likely elevated prior to January, causing the MMWWF to occur in November and December.

The DEQ methodology for MMWWF assumes that the precipitation from November and December serve to elevate the groundwater and saturate the soils. These soils are assumed to be saturated from January through May and the cumulative precipitation in that window creates a predictable response on the influent flows. A plot is created comparing the average precipitation and flows for January through May. The 1-in-5-year monthly precipitation totals for each month in January through May are fit to the data; the highest resulting flow is determined to be the MMWWF. January had the highest 1-in-5-year precipitation at 7.7 inches, resulting in a DEQ MMWWF of 3.2 mgd. Figure 3.6 shows the DEQ plot to determine MMWWF.

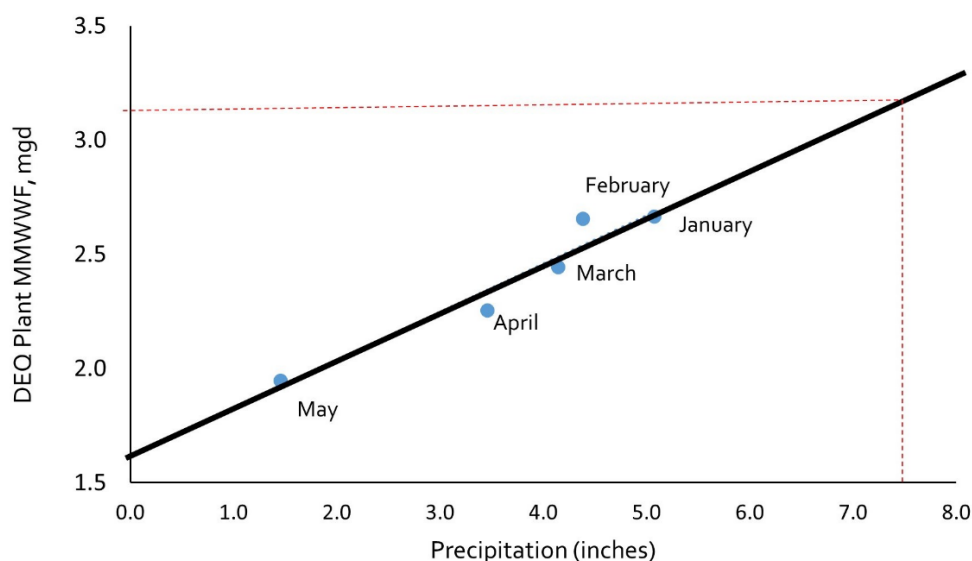

Figure 3.6 Maximum Month Wet Weather Flow DEQ Methodology

Table 3.10 shows the measured MMWWFs between the years 2015 and 2020 along with the industrial and R/C components of these numbers. The maximum R/C MMWWF peaking factor between 2015 and 2020, was 2.10 which was selected as the basis of planning. By multiplying this peaking factor by the selected R/C ABF of 1.68 mgd, the selected R/C MMWWF is calculated to be 3.54 mgd. The selected MMWWF of 3.73 mgd is then calculated by adding the maximum industrial flow of 0.19 mgd to the selected R/C MMWWF. The selected MMWWF is approximately 2 percent greater than the maximum measured historical MMWWF and is also greater than the MMWWF calculated using the DEQ methodology.

Table 3.10 Maximum Month Wet Weather Flows and Peaking Factors

Data Source	MMWWF ⁽¹⁾ (mgd)	Industrial ⁽¹⁾ (mgd)	R/C MMWWF ⁽²⁾ (mgd)	R/C Peaking Factor ⁽³⁾
2015 DMRs	3.45	0.16	3.29	2.10
2016 DMRs	2.86	0.16	2.70	1.68
2017 DMRs	3.69	0.17	3.53	2.10
2018 DMRs	2.83	0.14	2.68	1.59
2019 DMRs	2.50	0.14	2.37	1.40
2020 DMRs	2.90	0.14	2.76	1.67
DEQ Method	3.24	0.19 ⁽⁴⁾	3.05 ⁽⁵⁾	1.80 ⁽⁶⁾
Maximum Value (2015 – 2020)	3.69	0.17	3.53	2.10
Selected Value	3.73⁽⁸⁾	0.19⁽⁴⁾	3.54⁽⁷⁾	2.10

Notes:

- (1) Average monthly industrial flow that occurred in the month corresponding to the influent MMWWF.
- (2) R/C = MMWWF - Industrial.
- (3) Calculated by dividing the R/C MMWWF by the R/C ABF from Table 3.3.
- (4) The maximum combined SIU MMF flow from the last three years was assumed (Table 3.2).
- (5) The R/C MMWWF for the DEQ methodology was calculated by subtracting the assumed industrial flow from the DEQ methodology MMDWF.
- (6) The DEQ R/C MMDWF peaking factor was determined by dividing the resultant DEQ methodology R/C MMWWF by the selected R/C ABF from Table 3.3.
- (7) Calculated by multiplying the selected peaking factor by the selected R/C ABF from Table 3.3.
- (8) Calculated by adding the selected Industrial flow to the selected R/C MMWWF.

3.2.5 Maximum Weekly Flows

There is no DEQ guidance to calculate weekly flows; both the MWDWF and MWWWF were calculated using direct methodology based on 7-day running averages. The selected peaking factors will be utilized in Section 3.3 to project future flows. The methodology used to calculate the current flows and peaking factors is as follows:

- **R/C MWDWF and MWWWF peaking factors:** The R/C MWDWF and MWWWF peaking factors were calculated for each year between 2015 and 2020 by dividing the R/C MWDWF and MWWWFs by the R/C ABF for that year. Since selecting the largest peaking factor from 2015 through 2020 resulted in facility influent flows that were greater than five percent above the maximum observed facility influent flows, slightly lower peaking factors were selected. These peaking factors were selected by dividing the maximum observed R/C MWDWF and R/C MWWWF by the selected ABF.

- **Maximum week industrial flows:** Since weekly industrial flow data is not available, the average MM industrial flow from 2015 – 2020 was selected to represent the industrial contribution to the current MWDWF and MWWWF.
- **MWDWF and MWWF:** The selected current facility influent MWDWF and MWWWFs were calculated by adding the selected industrial flow to the selected R/C flow.

3.2.5.1 Maximum Week Dry Weather Flow

Table 3.11 details the measured MWDWF for the years 2015 through 2020 along with the industrial and R/C components of these numbers. The maximum R/C MWDWF peaking factor between 2015 and 2020 was 1.72, which occurred in the year 2016. If this peaking factor were used as the basis of planning, the selected MWDWF would be more than 5 percent greater than the maximum MWDWF measured in the last six years. To account for the lower MWDWF peaking factors observed in more recent years, a slightly lower MWDWF peaking factor of 1.64 was selected as the basis of planning. This peaking factor was selected as it yielded the maximum observed historic R/C MWDWF of 2.76 mgd. The selected MWDWF of 2.95 mgd is then calculated by adding the maximum industrial flow of 0.19 mgd to the selected R/C MWDWF.

Table 3.11 Maximum Week Dry Weather Flows and Peaking Factors

Data Source	MWDWF (mgd)	Industrial ⁽¹⁾ (mgd)	R/C MWDWF ⁽²⁾ (mgd)	R/C Peaking Factor ⁽³⁾
2015 DMRs	2.20	0.16	2.04	1.30
2016 DMRs	2.94	0.19	2.76	1.72
2017 DMRs	2.52	0.17	2.35	1.40
2018 DMRs	2.08	0.17	1.91	1.13
2019 DMRs	2.23	0.16	2.08	1.23
2020 DMRs	2.13	0.16	1.97	1.19
Maximum Value (2015 – 2020)	2.94	0.19	2.76	1.72
Selected Value	2.95⁽⁷⁾	0.19⁽⁴⁾	2.76⁽⁵⁾	1.64⁽⁶⁾

Notes:

- (1) No weekly industrial flow data is available. Used average monthly industrial flow that occurred in the month corresponding to the influent MWDWF.
- (2) R/C = MWDWF - Industrial.
- (3) Calculated by dividing the R/C MWDWF by the R/C ABF from Table 3.3.
- (4) No weekly industrial flow data is available. Used the maximum month industrial flow from the last three years (Table 3.2).
- (5) Highest calculate R/C MWDWF between 2015 and 2020 was selected as the current R/C MWDWF.
- (6) Calculated by dividing the selected R/C MWDWF by the selected ABF (Table 3.3).
- (7) Calculated by adding the selected Industrial flow to the selected R/C MWDWF.

3.2.5.2 Maximum Week Wet Weather Flow

Table 3.12 details the measured MWWWF for the years 2015 through 2020 along with the industrial and R/C components of these numbers. The maximum R/C MWWWF peaking factor between 2015 and 2020 was 2.78, which occurred in the year 2015. If this peaking factor were used as the basis of planning, the selected MWWWF would be more than 5 percent greater than the maximum MWWWF measured in the last six years. To account for the lower MWWWF peaking factors observed in more recent years, a slightly lower MWWWF peaking factor of 2.59 was selected as the basis of planning. This peaking factor was selected as it yielded a R/C MWWWF of 4.37 mgd, a value equal to the maximum observed historic R/C MWWWF. The selected MWWWF of 4.56 mgd is then calculated by adding the maximum industrial flow of 0.19 mgd to the selected R/C MWWWF.

Table 3.12 Maximum Week Wet Weather Flows and Peaking Factors

Data Source	MWWWF (mgd)	Industrial ⁽¹⁾ (mgd)	R/C MWWWF ⁽²⁾ (mgd)	R/C Peaking Factor ⁽³⁾
2015 DMRs	4.53	0.16	4.37	2.78
2016 DMRs	3.52	0.17	3.36	2.09
2017 DMRs	4.39	0.17	4.22	2.52
2018 DMRs	3.38	0.14	3.21	1.91
2019 DMRs	3.11	0.17	2.94	1.74
2020 DMRs	3.48	0.14	3.32	2.02
Maximum Value (2015 – 2020)	4.53	0.17	4.37	2.78
Selected Value	4.56⁽⁷⁾	0.19⁽⁴⁾	4.37⁽⁵⁾	2.59⁽⁶⁾

Notes:

- (1) No weekly industrial flow data is available. Used average monthly industrial flow that occurred in the month corresponding to the influent MWWWF.
- (2) R/C = MWWWF - Industrial.
- (3) Calculated by dividing the R/C MWWWF by the R/C ABF from Table 3.3.
- (4) No weekly industrial flow data is available. Used the maximum month industrial flow from the last three years (Table 3.2).
- (5) Highest calculate R/C MWWWF between 2015 and 2020 was selected as the current R/C MWWWF.
- (6) Calculated by dividing the selected R/C MWWWF by the selected ABF (Table 3.3).
- (7) Calculated by adding the selected Industrial flow to the selected R/C MWWWF.

3.2.6 Peak Day Flows

This section documents the historic PDDWF and PDWWF along with the historic PDDWF and PDWWF peaking factors. The selected peaking factors will be utilized in Section 3.3 to project future flows. The methodology used to calculate the current flows and peaking factors is as follows:

- **R/C PDDWF and PDWWF peaking factors:** The R/C PDDWF and PDWWF peaking factors were calculated for each year between 2015 and 2020 by dividing the R/C PDDWF and PDWWFs by the R/C ABF for that year. Additionally R/C PDDWF and PDWWF peaking factors were calculated from the estimated PDDWF and PDWWFs utilizing the DEQ methodology by subtracting the selected industrial flows from these calculated values. DEQ methodology R/C peaking factors were then calculated by dividing the DEQ methodology R/C flows by the selected ABF. Since selecting the largest peaking factor from 2015 through 2020 (including the peaking factor estimated utilizing the DEQ methodology) resulted in facility influent flows that were greater than five percent

above the maximum observed facility influent flows, slightly lower peaking factors were selected. These peaking factors were selected by dividing the maximum calculated R/C PDDWF and R/C PDWWF by the selected ABF.

- **Peak day industrial flows:** The average MM industrial flow from 2015 – 2020 was selected to represent the industrial contribution to the current PDDWF and PDWWF.
- **PDDWF and PDWWF:** The selected current facility influent PDDWF and PDWWFs were calculated by adding the selected industrial flow to the selected R/C flow.

3.2.6.1 Peak Day Dry Weather Flow

There is no DEQ methodology for PDDWF. Table 3.13 details the measured PDDWFs between the years 2015 and 2020 along with the industrial and R/C components of these numbers. The maximum R/C PDDWF peaking factor between 2015 and 2020 was 2.12, which occurred in the year 2016. If this peaking factor were used as the basis of planning, the selected PDDWF would be more than 5 percent greater than the maximum PDDWF measured in the last six years. To account for the lower PDDWF peaking factors observed in more recent years, a slightly lower PDDWF peaking factor of 2.04 was selected as the basis of planning. This peaking factor was selected as it yielded the maximum observed historic R/C PDDWF of 3.44 mgd. The selected PDDWF of 3.63 mgd is then calculated by adding the selected maximum industrial flow of 0.19 mgd to the selected R/C PDDWF.

Table 3.13 Peak Day Dry Weather Flows and Peaking Factors

Data Source	PDDWF (mgd)	Industrial ⁽¹⁾ (mgd)	R/C PDDWF ⁽²⁾ (mgd)	R/C Peaking Factor ⁽³⁾
2015 DMRs	2.63	0.16	2.46	1.57
2016 DMRs	3.63	0.19	3.44	2.14
2017 DMRs	3.19	0.17	3.02	1.80
2018 DMRs	2.25	0.17	2.08	1.23
2019 DMRs	3.06	0.17	2.89	1.70
2020 DMRs	2.29	0.16	2.13	1.29
Maximum Value (2015 – 2020)	3.63	0.19	3.44	2.14
Selected Value	3.63⁽⁷⁾	0.19⁽⁴⁾	3.44⁽⁵⁾	2.04⁽⁶⁾

Notes:

- (1) No daily industrial flow data is available. Used average monthly industrial flow that occurred in the month corresponding to the influent PDDWF.
- (2) R/C = PDDWF - Industrial.
- (3) Calculated by dividing the R/C PDDWF by the R/C ABF from Table 3.3.
- (4) No daily industrial flow data is available. Used the maximum month industrial flow from the last three years (Table 3.2).
- (5) Highest calculate R/C PDDWF between 2015 and 2020 was selected as the current R/C PDDWF.
- (6) Calculated by dividing the selected R/C PDDWF by the selected ABF (Table 3.3).
- (7) Calculated by adding the selected Industrial flow to the selected R/C PDDWF.

3.2.6.2 Peak Day Wet Weather Flow

DEQ recommends plotting the ten largest daily flows on record against the measured precipitation on that day. The 1-in-5-year 24-hour storm (2.9 inches) is then fit to the data to determine the PDWWF of 5.5 mgd. Figure 3.7 displays the DEQ methodology for determining PDWWF.

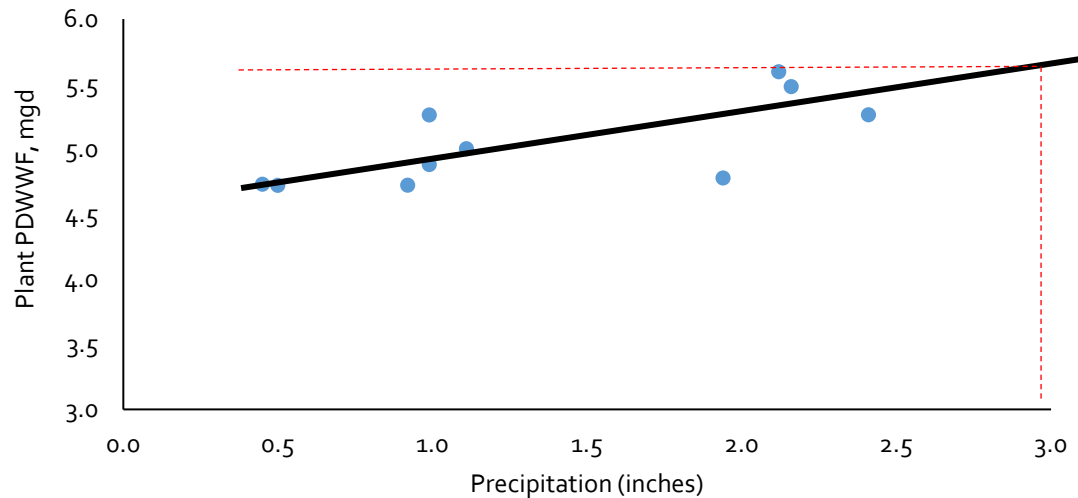

Figure 3.7 Peak Day Wet Weather Flow DEQ Methodology

Table 3.14 Peak Day Wet Weather Flows and Peaking Factors

Data Source	PDWWF (mgd)	Industrial ⁽²⁾ (mgd)	R/C PDWWF ⁽²⁾ (mgd)	R/C Peaking Factor ⁽³⁾
2015 DMRs	5.48	0.16	5.32	3.39
2016 DMRs	4.15	0.17	3.98	2.48
2017 DMRs	5.59	0.17	5.43	3.24
2018 DMRs	4.38	0.14	4.24	2.52
2019 DMRs	3.64	0.17	3.47	2.05
2020 DMRs	4.78	0.13 ⁽⁴⁾	4.65	2.82
DEQ Method	5.54	0.19 ⁽⁵⁾	5.35 ⁽⁶⁾	3.18 ⁽⁷⁾
Maximum Value (2015 – 2020)	5.59	0.17	5.43	3.39
Selected Value	5.62⁽⁸⁾	0.19⁽⁵⁾	5.43⁽⁹⁾	3.22⁽¹⁰⁾

Notes:

- (1) No daily industrial flow data is available. Used average monthly industrial flow that occurred in the month corresponding to the influent PDDWF.
- (2) R/C = PDWWF - Industrial.
- (3) Calculated by dividing the R/C PDWWF by the R/C ABF from Table 3.3.
- (4) Data is only available through June 2020. Since the PDWWF in 2020 occurred in December, the measured industrial flow for December of 2019 was assumed for this year.
- (5) No daily industrial flow data is available. Used the maximum month industrial flow from the last three years (Table 3.2).
- (6) The R/C PDWWF for the DEQ methodology was calculated by subtracting the assumed industrial flow from the DEQ methodology PDWWF.
- (7) The DEQ R/C PDWWF peaking factor was determined by dividing the resultant DEQ methodology R/C PDWWF by the selected R/C ABF from Table 3.3.
- (8) Calculated by adding the selected Industrial flow to the selected R/C PDWWF.
- (9) Highest calculate R/C PDWWF between 2015 and 2020 was selected as the current R/C PDDWF.
- (10) Calculated by dividing the selected R/C PDWWF by the selected ABF (Table 3.3).

3.2.7 Peak Hour Flow

The DEQ methodology for estimating PHF involves assigning probability of exceedances to determined design flows. The major assumption in the DEQ method is that all design flows are exceeded in a 1-in-5 probability precipitation year. The flows are plotted on a log-normal plot against the probability of exceedances, which are as follows:

- AAF: 50 percent.
- MMWWF: 8.3 percent (or one month in year).
- Peak Weekly Flow: 1.9 percent (or one week in a year).
- PDWWF: 0.27 percent (or one day in a year).
- PHF 0.011 percent (or one hour in a year).

Using this methodology, the estimated PHF is estimated to be 7.78 mgd as is shown in Figure 3.8. The DEQ methodology R/C PHF was estimated by subtracting the selected MM industrial flow (Table 3.2) from the PHF generated using the DEQ methodology. A R/C DEQ PHF peak factor equal to 4.51 was then calculated by dividing this flow by the selected R/C ABF from Table 3.3.

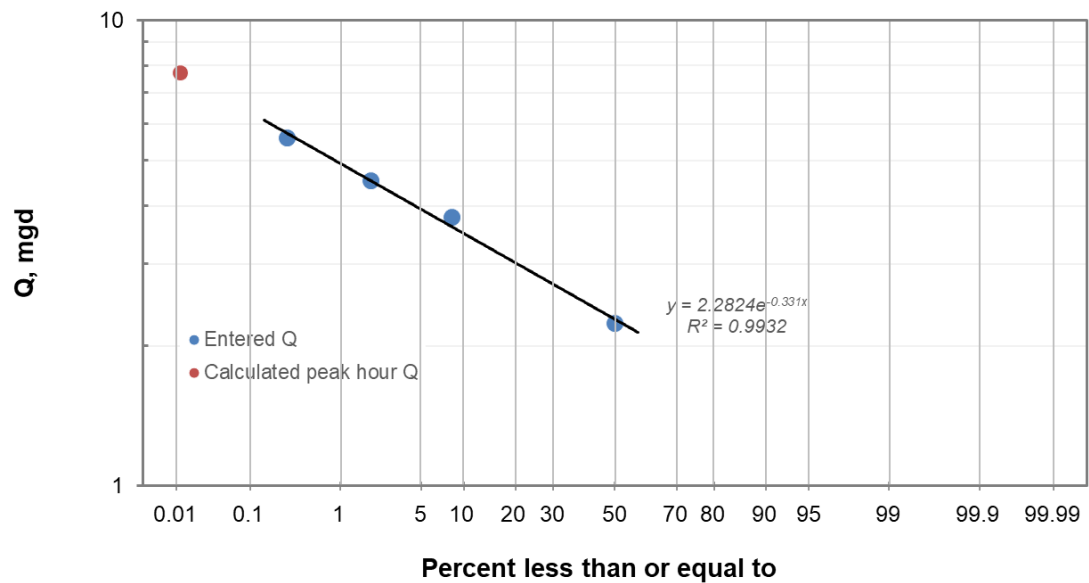

Figure 3.8 Peak Hour Flow DEQ Methodology

Instantaneous plant data from 2015-2020 was provided by the City and gives measurements every 15 minutes. A running average was performed to determine the hourly flows. These measured PHFs for the years 2015 through 2020 are summarized in Table 3.15. The highest hourly flow recorded was 8.79 mgd on December 7, 2015, which saw 2.2 inches of rain. This event also produced the greatest R/C peaking factor of 5.50 which also exceeded the R/C DEQ PHF peaking factor. If this peaking factor were used as the basis of planning, the selected PHF would be more than 5 percent greater than the maximum PHF measured in the last six years. To account for the lower peaking factors observed in more recent years, a slightly lower PHF peaking factor of 5.10 was selected as the basis of planning. This peaking factor was selected as it yielded the maximum observed historic PHF of 8.79 mgd.

Table 3.15 Peak Hour R/C Flows Peaking Factors

Data Source	PHF (mgd)	Industrial ⁽¹⁾ (mgd)	R/C PHF ⁽²⁾ (mgd)	R/C Peaking Factor ⁽³⁾
2015 Plant Data	8.79	0.16	8.63	5.50
2016 Plant Data	5.64	0.17	5.47	3.40
2017 Plant Data	6.95	0.17	6.78	4.04
2018 Plant Data	5.78	0.14	5.64	3.35
2019 Plant Data	4.54	0.15	4.39	2.59
2020 Plant Data	5.15	0.14	5.01	3.04
DEQ Method	7.78	0.19 ⁽⁴⁾	7.59 ⁽⁵⁾	4.51 ⁽⁶⁾
Maximum Value (2015 – 2020)	8.79	0.19	8.63	5.50
Selected Value	8.79⁽⁷⁾	0.19⁽⁴⁾	8.60⁽⁸⁾	5.10⁽⁹⁾

Notes:

- (1) No hourly industrial flow data is available. Used average monthly industrial flow that occurred in the month corresponding to the influent PHF.
- (2) R/C PHF = PHF - Industrial.
- (3) Calculated by dividing the R/C PHF by the R/C ABF from Table 3.3.
- (4) No hourly industrial flow data is available. Used the maximum month industrial flow from the last three years (Table 3.2).
- (5) The R/C PHF for the DEQ methodology was calculated by subtracting the assumed industrial flow from the DEQ methodology PHF.
- (6) The DEQ R/C PHF peaking factor was determined by dividing the resultant DEQ methodology R/C PHF by the selected R/C ABF from Table 3.4.
- (7) Highest PHF between 2015 and 2020 was selected as the current PHF.
- (8) Calculated by subtracting the selected industrial flow from the selected current PHF.
- (9) Calculated by dividing the selected R/C PHF by the selected ABF (Table 3.3).

3.2.8 Existing Flow Summary

Table 3.16 below details the existing flows calculated and explained in this section. The R/C peaking factor will serve as the basis for flow projections.

Table 3.16 Existing (2020) Flow Summary

Item	Selected Flow (mgd)	Industrial Flow (mgd)	R/C Flow (mgd)	R/C Peaking Factor
ABF	1.85	0.17	1.68	1.00
AAF	2.17	0.17	2.00	1.19
ADWF	1.91	0.17	1.74	1.03
AWWF	2.53	0.17	2.36	1.40
MMDWF	2.51	0.19	2.32	1.38
MMWWF	3.73	0.19	3.54	2.10
MWDWF	2.95	0.19	2.76	1.64
MWWWF	4.56	0.19	4.37	2.59
PDDWF	3.63	0.19	3.44	2.04
PDWWF	5.62	0.19	5.43	3.22
PHF	8.79	0.19	8.60	5.10

3.3 Flow Projections

Flow projections were developed by adding the projected industrial flow to the projected R/C flows. This section documents the industrial flow projections along with the projections for the R/C and combined flows.

3.3.1 Industrial Flow Projection

Certain SIUs within the City's existing service area have permitted flow (and in one case load) limits established by the City. Industrial flows for these permitted SIUs was to equal the maximum permitted flow by the year 2045. Since weekly, daily and hourly data are not available for industrial flows, this permitted maximum flows was assumed to equal the MMDWF, MMWWF, MWDWF, MWWWF, PDDWF, PDWWF and PHF for each SIU. This assumption results in a projected 2045 maximum flow from the SIUs within the current industrial areas of 0.58 mgd. The projected average flows from the SIUs (ABF, AAF, ADWF and AWWF) were calculated by multiplying the selected 2045 MMF by the ratio of the current selected average SIU flow (0.17 mgd) to the current selected maximum month SIU flow (0.19 mgd). With this assumption, the City's current largest industrial sources (Swire and CCF) would increase their maximum effluent flow up to the limits currently set by the City which represents an approximately 250 and 150 percent growth over current flow generation, respectively while the smaller SIUs would see much larger growth percentages. Table 3.17 summarizes the methodology used to project the 2045 industrial AAF and MMFs from the City's current SIUs.

In addition to the current SIUs, the CSMP (2014) projects that 1,220 acres within the UGB could be zoned for industrial use by the year 2045. The projected 2045 AAF and MMF from these new areas was projected using the following methodology:

- **New total industrial area:**
 - 1,220 acres (The sum of the “Future Development UGB” industrial designed category and the “Future Development UGB” industrial re-zone from Table 2-2 from the CSMP, 2014).
 - 53.2 acres of that lies within the BCPA and is planned to be served by others.
 - 1,166.8 acres thus represents the planned new industrial area for 2045.
- **New buildable industrial area:** 65 percent of 1,166.8 acres or 758 acres. This reduction accounts for the net buildable area (Page 5-13, CSMP 2014).
- **New industrial area AAF:** 350 gallons per acre per day (gpad) flow factor multiplied by 758 acres. This flow factor is from Table 5-10 in the CSMP (2014) and represents a “low density” flow for industrial areas. This flow factor was selected because it is more similar to the current industrial flow of about 170 gpad than the “medium density” flow factor of 500 gpad or the “high density” flow factors of 1,000 gpad presented in the CSMP. This results in a projected industrial AAF of 0.27 mgd. This flow applies to all the average flows (AAF, ADWF, AWWF and ABF).
- **New industrial area MMF:** The new industrial area MMF was calculated by multiplying the new industrial area AAF by the ratio of the current industrial MMF to AAF and equals 0.30 mgd.

The projected 2045 permitted industrial flows are the sum of the flows projected for the current industrial area and the areas within the UGB that could be zoned for industrial uses in the future. These flows are summarized in Table 3.18. By using this methodology, the industrial flow is projected to grow by 460 percent through the year 2045 and results in a per acre AAF of 414 gpad. While this represents a 240 percent increase in the industrial flow factor, it is about half of the “high density” industrial flow factor assumed in the CSMP.

Since the flows associated with the non-permitted industrial sources is not tracked, this flow is part of the calculated R/C flow and is assumed to grow with the residential population.

Table 3.17 Industrial Flow Projections for the Current Industrial Area

Item	Current AAF (mgd)	Percent of Current AAF	Calculated Current MMF (mgd) ⁽¹⁾	Permitted Maximum Flow (mgd)	Growth Potential ⁽²⁾	Selected 2045 AAF (mgd) ⁽³⁾	Selected 2045 MMF (mgd) ⁽⁴⁾
Swire	0.06	33%	0.06	0.16	254%	0.14	0.16
ODOC	0.09	55%	0.10	0.16	153%	0.14	0.16
Fujimi	0.01	8%	0.02	0.12	776%	0.11	0.12
Xerox	0.00	1%	0.00	0.025	1095%	0.02	0.03
Flir	0.00	0%	0.00	0.006	4527%	0.01	0.01
SIUs with no permitted maximum ⁽⁵⁾	0.00	3%	0.01	NA	NA	0.00	0.01
SIUs with no monitoring data	NA			0.106	NA	0.09	0.11
Total	0.17		0.19	0.577	334%	0.52	0.58

Notes:

- (1) Since the MMFs of each SIU do not necessarily occur at the same time, the MMF for each SIU was calculated by multiplying each SIUs percent of current AAF by the selected current SIU MMF from Table 3.2.
- (2) Calculated by dividing the permitted maximum flow by the calculated MMF.
- (3) Calculated by multiplying the selected MMF for each SIU by the ratio of the current total SIU AAF to MMF from Table 3.2.
- (4) Selected MMF for each SIU equals the permitted maximum flow if available or the current MMF if no permitted flows are available.
- (5) SIUs with no permitted maximum flow include: Sysco and Leadteck.
- (6) SIUs with no monitoring data include: Photo Solutions, Old Castle, Twist Bioscience, DAS North Valley Complex, PW Building and Marten Transport.

Table 3.18 Industrial Flow Projections

	Current Industrial Area	New Industrial Area	Combined Industry
2020			
Area, acres	1,000 ⁽¹⁾	0	1,000
AAF, gpad	170	NA	170
AAF, mgd	0.17	NA	0.17
MMF, mgd	0.19	NA	0.19
2045			
Area, acres	1,000	758 ⁽²⁾	1,758
AAF, gpad	516	350	444
AAF, mgd	0.52	0.27	0.78
MMF, mgd	0.58	0.30	0.87

Notes:

(1) From Table 2-2 of the CSMP (2014).

(2) $0.65 \times (1220 \text{ acres [Table 2-2 CSMP 2014]} - 53.2 \text{ acres [BCPA]})$.

3.3.2 Total Influent Flow Projection

To produce a total influent (combined industrial and R/C) flow projection for the planning period, the R/C ABF was first projected by multiplying the selected R/C per capita flow of 65 gpcd (Table 3.3) by the projected 2045 population of 50,388 (Section 3.1.1). The remaining R/C flows were developed by multiplying the selected peaking factors (Section 3.3) by the projected R/C ABF. The total influent flow was then projected by adding the projected industrial flows (Table 3.18) to the projected R/C flows. Total influent flow projections for the year 2045 are summarized in Table 3.19.

Table 3.19 2045 Flow Projections

Item	Existing R/C Flow (mgd)	R/C Peaking Factor	2045 R/C Flow	2045 Industrial Flow (mgd)	Projected 2045 Plant Flow (mgd)
ABF	1.7	1.0	3.3	0.78	4.1
AAF	2.1	1.2	4.0	0.78	4.8
ADWF	1.7	1.0	3.4	0.78	4.2
AWWF	2.4	1.4	4.6	0.78	5.4
MMDWF	2.3	1.4	4.5	0.87	5.4
MMWWF	3.5	2.1	6.9	0.87	7.8
MWDWF	2.8	1.6	5.4	0.87	6.2
MWWWF	4.4	2.6	8.5	0.87	9.4
PDDWF	3.4	2.0	6.7	0.87	7.6
PDWWF	5.4	3.2	10.5	0.87	11.4
PHF	8.6	5.1	16.7	0.87	17.6

As is shown in Table 3.20, the 2045 PHF developed for this Plan of 17.6 mgd is approximately 5.9 mgd less than the 2045 PHF developed during the CSMP (2014). This difference is primarily due to the different assumptions applied to estimate industrial flow. The CSMP assumed that the industrial flow would grow from a current base flow (un-peaked) of 0.2 mgd (CSMP Table 5-3) to a future base flow of around 2.6 mgd (future gross area zoned for industrial use (CSMP Table 2-2) multiplied by a 65 percent factor to convert the gross acreage to net acreage (CSMP Page 5-13), multiplied by 1000 gpad for the designated industrial areas and 2,492 gpad for the re-zone industrial areas (CSMP Table 5-13). This represents a 13 fold increase in the base industrial flow. The CSMP also assumed that the maximum recorded DWF peaking factor for Canyon Creek applied to all flows including the industrial flows (CSMP Page 5-14 and Table 6-1). Between these two assumptions (13-fold increase in base flow and a peaking factor of 2.3 on the base industrial flow), the CSMP projected that the peak industrial flow would increase from about 0.3 mgd to 5.9 mgd by the year 2045, which represents a 17 fold increase in peak industrial flow. Additionally, by the year 2045, the CSMP is projecting that 41 percent of the flow coming to the treatment plant will be from industrial sources.

The growth in industrial flows projected as part of the CSMP is in contrast to the industrial flow growth projected as part of this plan. This plan projects that the peak industrial flow will increase from 0.19 mgd to 0.87 mgd by the year 2045, which represents a 4.6 fold increase in industrial flows. Over this same period, the R/C flows are expected to almost double and thus this Plan is projecting that the growth in industrial flow will outpace the R/C growth by more than a factor of two.

These different industrial flow assumptions were discussed with the City on April 20, 2023 and the group decided that the lower industrial flows projected in this plan are in line with the assumption that future industrial growth will be similar in nature to the City's current industries. The group felt that the industrial flow assumptions from the CSMP were conservative and appropriate for sizing collection system assets but that the approach outlined in this Plan provides a more realistic approach to planning for future expansions at the WWTP where overly conservative assumptions can yield inefficient and difficult to operate processes. The group discussed that the City should closely monitor industrial flow and growth and revise this planning document if necessary to accommodate future changes in industrial flows not accounted for by this Plan.

Table 3.20 Comparison of 2045 CSMP Flow Projections to the Current Plan's Projections

	CSMP	Current Plan	Difference (CSMP – Current Plan)
Industrial DWF	5.88 ⁽¹⁾	0.87 ⁽²⁾	5.01
R/C DWF	8.32 ⁽³⁾	6.70 ⁽²⁾	1.62
WWF	9.26 ⁽⁴⁾	10.00 ⁽⁵⁾	-0.74
PHF	23.46 ⁽⁶⁾	17.57 ⁽⁷⁾	5.89

Notes:

- (1) Calculated as follows: sum of (1) existing industrial flow = 0.2 (CSMP Table 5-3) x 1.7 peaking factor (CSMP Table 5-5 used value for the WWTP); (2) future industrial flow = future gross area zoned for industrial use (CSMP Table 2-2) * 0.65 conversion from gross area to net area (CSMP page 5-13) * 1000 gpad for designated industrial areas and 2,492 gpad for the re-zone industrial areas (CSMP Table 5-13) * 2.3 peaking factor (CSMP Page 5-14 and Table 6-1).
- (2) Table 3.19 PDDWF.
- (3) Sum of Existing DWF, Future UGB DWF and Future URA DWF from CSMP Table 5-15 less the CSMP Industrial DWF.
- (4) Sum of the Existing WWF, Future UGB WWF and Future URA WWF from CSMP Table 5-15.
- (5) PHF – PDDWF from Table 3-19.
- (6) CSMP Table 5-15.
- (7) Table 3-19 PHF.

3.4 Historical and Existing Loads

Historical loading was gathered from the DMRs for the years 2015 through 2020. The DMRs displayed data for twice-weekly sampling events for BOD₅ and TSS. Nitrogen measurements were available from 2017 through 2019. Influent total phosphorous (TP) concentrations were not available on the DMRs, so their loading was estimated using standard published ratios.

The following parameters were defined for BOD₅, TSS, ammonia (NH₃), and TP loads. There is no DEQ methodology for load analysis, so all measurements were from direct calculation:

- **Average Annual (AA):** The average load over a calendar year.
- **Maximum Month (MM):** The maximum 30-day running average load.
- **Maximum Week (MW):** The maximum 7-day running average load.
- **Peak Day (PD):** The maximum daily load.

This section develops the per capita loads, industrial contributions and peaking factors used as the basis of future load projections. The methodology used to calculate the current loads and peaking factors is as follows:

- **Industrial loads:**
 - **BOD₅ and TSS:** Since flows and loads are only available from the permitted industrial sources, this section discusses the methodology used to estimate the current permitted industrial loads. The non-permitted industrial loads are part of the calculated R/C loads. Monthly industrial data was used to calculate the AA and MM industrial loads for the years 2015 through 2020. The average of AA and MM values was selected for the current AA and MM industrial contribution. Since no weekly or daily industrial data is available, the MM industrial contribution was also assumed for the MW and PD industrial contribution.
 - **Ammonia:** Since no industrial data is available for ammonia, the industrial load was assumed to have the same concentration as the influent. Using this methodology, AA and MM industrial ammonia loads were estimated for the years 2015 through 2020. The average of AA and MM values was selected for the current AA and MM industrial contribution. Additionally, the estimated industrial MM ammonia load was assumed for the MW and PD industrial contribution.
 - **TP:** Since no data is for either the industrial TP concentration or the facility influent TP concentration, TP concentrations can be estimated as a fraction of BOD₅ concentration. Table 3.18 of Metcalf & Eddy Fifth Edition lists TP concentrations as three percent of BOD₅ concentrations in typical domestic wastewater. This percentage was assumed for the industrial loads as well and was used to estimate industrial TP loads.
- **R/C AA per capita loads:** R/C AA loads were calculated for each year by subtracting the selected AA industrial load from the measured influent loads. The R/C AA per capita loads were calculated by dividing the load by the estimated population for that year. The average per capita load between 2015 and 2020 was selected to represent the current condition.
- **R/C MM, MW and PD peaking factors:** The R/C MM, MW and PD loads were calculated by subtracting the measured industrial load during the month that the peak load occurred from the measured influent load. The R/C peaking factors were calculated for each year by dividing that peak load by the AA load. A "current" load was then

calculated by adding the selected MM industrial load to the multiplication of the maximum peak factor between 2015 and 2020 by the selected R/C AA load. If this load was less than 5 percent greater than the maximum observed facility influent load, this peaking factor was selected to represent the R/C peak condition. If this calculated load was greater than 5 percent above the maximum observed facility influent load, a lower peak factor was selected that corresponded to the maximum observed R/C load.

- **MM, MW and PD loads:** R/C MM, MW and PD loads were calculated by multiplying the selected peak factors by the selected AA load. The facility influent MM, MW and PD loads were then calculated by adding the selected MM industrial load to the calculated R/C MM, MW and PD loads.
- **R/C AA, MM, MW and PD TP loads:** Since not data is available on the influent TP concentration, the AA, MM, MW, PD loads as well as the R/C AA, MM, MW and PD TP loads were estimated by assuming that the influent TP concentrations are 3 percent of the influent BOD concentrations (Table 3.18 from Metcalf and Eddy 5th Edition).

3.4.1 Total Suspended Solids

This section summarizes the historical data for industrial TSS loads along with the facility influent and R/C TSS loads.

3.4.1.1 Industrial TSS Loads

The City's system receives a significant contribution from permitted industrial sources. These sources are considered SIUs and are regulated through the City's pre-treatment program. TSS data was obtained from the City's pre-treatment coordinator for the following permitted contributors:

1. **Fujimi:** Manufacturer of a variety of lapping and polishing products.
2. **Xerox:** Manufacturer of printers and other technology supplies.
3. **Swire Pacific:** Bottling plant for Coca-Cola™ products.
4. **Flir:** Tech manufacturer of thermal imaging and night vision cameras.
5. **Oregon Department of Corrections (ODOC):** Prison with a capacity of approximately 1,684 people, specifically the Coffee Creek Correctional Facility (CCCF). This prison is the only female prison in the state and is the on-boarding facility for all male prisoners.
6. **Sysco:** Supplier of kitchen goods. Elevated TSS was previously measured here when truck washing occurred on site, however that operation reportedly ceased in 2019.

The City's pre-treatment program primarily monitors metal concentrations, so comprehensive coverage of BOD₅ and TSS were not always available. TSS data was provided on a monthly-average basis. If average concentrations of BOD₅ and/or TSS were not available, the peak concentration for that month was used as a conservative basis. Typically, when this assumption was used, flows were low and/or the peak concentrations were low, and the resulting mass load was still very small relative to total plant loads with combined industrial loads accounting for approximately 6 percent of the influent TSS loads. For TSS loads, ODOC's contribution accounts for 89 percent of the Industrial TSS. Table 3.21 summarizes the combined AA and MM industrial loads. The average of the AA and MM industrial TSS loads were assumed when estimating the current facility influent TSS loads. Since weekly and daily industrial flows and TSS concentrations were not available, the MM industrial TSS load was also assumed for the MW and PD conditions.

Table 3.21 Annual Average and Maximum Monthly Industrial TSS Contributions

Year	AA TSS load (ppd)	MM TSS load (ppd)
2015	427	672
2016	470	655
2017	449	636
2018	412	655
2019	435	846
2020	293	389
Average	414	642

3.4.1.2 Average Annual TSS Loads

Average Annual TSS loads from 2015 through 2020 are reported in Table 3.22 and indicate increased loading primarily from the R/C contributors. As mentioned previously, industrial TSS comes primarily from the prison. Between the years 2015 and 2020, the average per capita TSS load was 0.23 pounds per capita day (ppcd) which is within the expected range. The selected R/C AA load was calculated by multiplying the selected per capita load by the 2020 PSU PRC population estimates. The selected AA load was calculated by adding the average annual industrial load of 414 ppcd to the calculated R/C AA load.

Table 3.22 Average Annual TSS Load

Data Source	Population ⁽¹⁾	Facility ⁽²⁾ (ppd)	Industrial (ppd)	R/C ⁽³⁾ (ppd)	R/C Per Capita (ppd) ⁽⁴⁾
2015 DMRs	22,870	5,201	426	4,775	0.21
2016 DMRs	23,740	5,600	470	5,130	0.22
2017 DMRs	24,315	6,904	450	6,454	0.27
2018 DMRs	25,250	6,275	413	5,863	0.23
2019 DMRs	25,635	6,635	435	6,201	0.24
2020 DMRs	25,915	6,471 ⁽⁵⁾	296	6,175	0.24
Average Value (2015 – 2020)	–	6,181	415	5,766	0.23
Selected Value	25,915⁽⁶⁾	6,472⁽⁷⁾	414⁽⁸⁾	6,058⁽⁹⁾	0.23

Notes:

- (1) Certified PSU PRC estimates.
- (2) Direct average from influent readings on DMRs for the water year (November 1st of the previous calendar year through October 31st).
- (3) R/C = Facility – Industrial.
- (4) Calculated by dividing the R/C load by the population.
- (5) Industrial data only available through June of 2020.
- (6) 2020 population.
- (7) Calculated by adding the selected industrial load to the selected R/C load.
- (8) Average of the AA values from Table 3.21.
- (9) Calculated by multiplying the selected per capita load by the selected population.

3.4.1.3 Maximum Month TSS Loads

The MM TSS loads are reported in Table 3.23 for the years 2015 through 2020. Between the years 2015 and 2020, the maximum MM peaking factor was 1.36 which occurred in the year 2016. This peaking factor was used as the basis of planning and was multiplied by the selected R/C AA TSS load to calculate the selected R/C MM TSS load of 8,242 ppd. The selected MM TSS load of 8,884 ppd was calculated by adding the maximum industrial TSS load to the selected R/C maximum month TSS load. This selected load is within 5 percent of the MM TSS load of 8,835 ppd measured in the year 2017.

Table 3.23 Maximum Month TSS Loads and Peaking Factors

Data Source	Facility ⁽¹⁾ (ppd)	Industrial ⁽²⁾ (ppd)	R/C ⁽³⁾ (ppd)	R/C Peaking Factor ⁽⁴⁾
2015 DMRs	5,906	454	5,452	1.14
2016 DMRs	7,358	361	6,997	1.36
2017 DMRs	8,835	481	8,354	1.29
2018 DMRs	7,445	489	6,956	1.19
2019 DMRs	7,820	466	7,353	1.19
2020 DMRs	7,662	234	7,428	1.20
Maximum Value (2015 – 2020)	8,835	489	8,354	1.36
Selected Value	8,906⁽⁵⁾	642⁽⁶⁾	8,264⁽⁷⁾	1.36

Notes:

- (1) Maximum 30-day running average.
- (2) Equal to the 30-day average industrial load occurring at the same time as the maximum 30-day average of the facility influent. Since maximum month industrial loads may not occur at the same time as the maximum month of the facility influent loads, the loads shown here, may be different than the loads summarized in Table 3.21.
- (3) Facility Influent – Industrial.
- (4) Calculated by dividing the R/C maximum month load by the R/C average annual load from Table 3.22.
- (5) Calculated by adding the selected industrial load to the selected R/C load.
- (6) Average of the MM values in Table 3.21.
- (7) Calculated by multiplying the selected R/C AA load from Table 3.22 by the selected peaking factor.

3.4.1.4 Maximum Week TSS Loads

The MW TSS loads are reported in Table 3.24 for the years 2015 through 2020. During this time, the peaking factors ranged from 1.45 to 1.92, with the maximum peaking factor occurring in the year 2016. If this peaking factor is used as the basis of calculating MW loads, the selected loads would exceed the maximum measured values by around 9 percent. Given the fact that considerably lower peaking factors were recorded in recent years, a lower peaking factor of 1.74 was selected. This value corresponds to the maximum calculated R/C load of 10,531 ppd. The selected MW TSS load was calculated by adding the maximum industrial load of 642 ppd to the selected MW R/C load.

Table 3.24 Maximum Week TSS Loads and Peaking Factors

Data Source	Facility ⁽¹⁾ (ppd)	Industrial ⁽²⁾ (ppd)	R/C ⁽³⁾ (ppd)	R/C Peaking Factor ⁽⁴⁾
2015 DMRs	8,390	260	8,130	1.70
2016 DMRs	10,280	383	9,897	1.93
2017 DMRs	10,953	422	10,531	1.63
2018 DMRs	8,700	174	8,525	1.45
2019 DMRs	10,959	481	10,478	1.69
2020 DMRs	9,208	234	8,974	1.45
Maximum Value (2015 – 2020)	10,959	481	10,531	1.93
Selected Value	11,173⁽⁵⁾	642⁽⁶⁾	10,531⁽⁷⁾	1.74⁽⁸⁾

Notes:

- (1) Maximum 7-day average.
- (2) Monthly average industrial load that occurred in the month containing the maximum weekly facility influent load. Since the maximum facility influent and industrial loads may not occur at the same time, the industrial loads listed here may differ from those summarized in Table 3.21.
- (3) Facility influent – industrial.
- (4) Calculated by dividing the R/C maximum week load by the R/C average annual load from Table 3.22.
- (5) Calculated by adding the selected industrial load to the selected R/C load.
- (6) Since weekly data is not available for industrial loads, used the average of the MM values in Table 3.21.
- (7) Selected the largest R/C load from 2015 – 2020.
- (8) Calculated by dividing the maximum R/C load by the selected AA R/C load from Table 3.22.

3.4.1.5 Peak Day TSS Loads

The PD TSS loads are reported in Table 3.25 for the years 2015 through 2020. During this time, the peaking factors ranged from 1.70 to 2.69, with the maximum peaking factor occurring in the year 2016. If this peaking factor is used as the basis of calculating peak day loads, the selected loads would exceed the maximum measured values by around 16 percent. Given the fact that considerably lower peaking factors were recorded in recent years, a lower peaking factor of 2.28 was selected. This value corresponds to the maximum calculated R/C load of 13,800 ppd. The selected PD TSS load was calculated by adding the maximum industrial load of 642 ppd to the selected PD R/C load.

Table 3.25 Peak Day TSS Loads and Peaking Factors

Data Source	Facility (ppd)	Industrial ⁽¹⁾ (ppd)	R/C ⁽²⁾ (ppd)	R/C Peaking Factor ⁽³⁾
2015 DMRs	9,386	324	9,062	1.90
2016 DMRs	14,184	383	13,800	2.69
2017 DMRs	14,020	462	13,558	2.10
2018 DMRs	12,629	283	12,346	2.11
2019 DMRs	12,230	380	11,850	1.91
2020 DMRs	10,753	234	10,519	1.70
Maximum Value (2015 – 2020)	14,184	462	13,800	2.69
Selected Value	14,442⁽⁴⁾	642⁽⁵⁾	13,800⁽⁶⁾	2.28⁽⁷⁾

Notes:

- (1) Monthly average industrial load that occurred in the month containing the maximum day facility influent load. Since the maximum facility influent and industrial loads may not occur at the same time, the industrial loads listed here may differ from those summarized in Table 3.21.
- (2) Facility influent – industrial.
- (3) Calculated by dividing the R/C peak day load by the R/C average annual load from Table 3.22.
- (4) Calculated by adding the selected industrial load to the selected R/C load.
- (5) Since daily data is not available for industrial loads, used the average of the MM values in Table 3.21.
- (6) Selected the largest R/C load from 2015 – 2020.
- (7) Calculated by dividing the maximum R/C load by the selected AA R/C load from Table 3.22.

The summary of TSS loads is found in Table 3.26.

Table 3.26 TSS Existing Loads Summary

Data Source	Facility (ppd)	Industrial (ppd)	R/C (ppd)	R/C Peaking Factor
Annual Average	6,472	414	6,058	1.00
Maximum Month	8,906	642	8,264	1.36
Maximum Week	11,173	642	10,531	1.74
Peak Day	14,442	642	13,800	2.28

3.4.2 Biochemical Oxygen Demand

This section summarizes the historical data for industrial BOD₅ loads along with the facility influent and R/C BOD₅ loads.

3.4.2.1 Industrial BOD₅ Loads

The City's system receives a significant contribution from permitted industrial sources. BOD₅ data was obtained from the City's pre-treatment coordinator on the following permitted contributors: Fujimi, Xerox, Swire Pacific, Flir, ODOC and Sysco.

BOD₅ data was provided on a monthly-average basis and accounts for approximately 10 percent of the influent BOD₅ loads. For BOD₅ loads, the sum of the Swire and ODOC's loads accounts for 97 percent of the Industrial BOD₅ loads. Table 3.27 summarizes the combined AA and MM industrial loads. The average of the AA and MM industrial BOD₅ loads were assumed when estimating the current facility influent BOD₅ loads. Since weekly and daily industrial flows and BOD₅ concentrations were not available, the MM industrial BOD₅ load was also assumed for the MW and PD conditions.

Table 3.27 Annual Average and Maximum Monthly Industrial BOD₅ Contributions

Year	AA BOD ₅ load (ppd)	MM BOD ₅ load (ppd)
2015	786	1,271
2016	829	1,681
2017	714	1,039
2018	605	778
2019	642	906
2020	874	1,621
Average	742	1,216

3.4.2.2 Average BOD₅ Loads

Average Annual BOD₅ loads are reported in Table 3.28. Between the years 2015 and 2020, the average per capita BOD₅ load was 0.26 ppcd, which is on the high side of the expected range. The selected R/C AA load was calculated by multiplying the selected per capita load by the 2020 population. The selected AA load was calculated by adding the AA industrial load of 742 ppd to the calculated R/C AA load.

Table 3.28 Average Annual BOD₅ Load

Data Source	Population ⁽¹⁾	Facility ⁽²⁾ (ppd)	Industrial (ppd)	R/C ⁽³⁾ (ppd)	R/C Per Capita (ppd) ⁽⁴⁾
2015 DMRs	22,870	6,741	787	5,954	0.26
2016 DMRs	23,740	7,226	827	6,399	0.27
2017 DMRs	24,315	7,348	716	6,632	0.27
2018 DMRs	25,250	6,941	604	6,336	0.25
2019 DMRs	25,635	7,237	643	6,594	0.26
2020 DMRs	25,915	7,563	890 ⁽⁵⁾	6,673	0.26
Average Value (2015 – 2020)		7,176	744	6,431	0.26
Selected Value	25,915⁽⁶⁾	7,516⁽⁷⁾	742⁽⁸⁾	6,774⁽⁹⁾	0.26

Notes:

- (1) Certified PSU PRC estimates.
- (2) Direct average from influent readings on DMRs for the water year (November 1st of the previous calendar year through October 31st).
- (3) R/C = Facility – Industrial.
- (4) Calculated by dividing the R/C load by the population.
- (5) Industrial data only available through June of 2020.
- (6) 2020 population.
- (7) Calculated by adding the selected industrial load to the selected R/C load.
- (8) Average of the AA values from Table 3.27.
- (9) Calculated by multiplying the selected per capita load by the selected population.

3.4.2.3 Maximum Month BOD₅ Loads

The MM BOD₅ loads are reported in Table 3.29. Between the years 2015 and 2020, the maximum month peaking factor ranged from 1.12 to 1.43, with the maximum peak factor of 1.43 occurring in the year 2017. To account for the lower peak factors observed in recent years, a slightly lower peak factor of 1.40 was selected as the basis of planning. This peak factor corresponds to the maximum calculated R/C load of 9,469 ppd. The selected MM load of 10,685 ppd was calculated by adding the maximum industrial BOD₅ load to the selected R/C MM BOD₅ load. This selected load is approximately 5 percent greater than the maximum measured MM BOD₅ load of 10,220 ppd measured in the year 2017.

Table 3.29 Maximum Month BOD₅ Loads and Peaking Factors

Data Source	Facility ⁽¹⁾ (ppd)	Industrial ⁽²⁾ (ppd)	R/C ⁽³⁾ (ppd)	R/C Peaking Factor ⁽⁴⁾
2015 DMRs	7,692	1026	6,666	1.12
2016 DMRs	9,177	1270	7,907	1.24
2017 DMRs	10,220	751	9,469	1.43
2018 DMRs	8,876	592	8,284	1.31
2019 DMRs	8,409	541	7,868	1.19
2020 DMRs	8,914	657	8,257	1.24
Maximum Value (2015 – 2020)	10,220	1,270	9,469	1.43
Selected Value	10,685⁽⁵⁾	1,216⁽⁶⁾	9,469⁽⁷⁾	1.40⁽⁸⁾

Notes:

- (1) Maximum 30-day running average.
- (2) Equal to the 30-day average industrial load occurring at the same time as the maximum 30-day average of the facility influent. Since maximum month industrial loads may not occur at the same time as the maximum month of the facility influent loads, the loads shown here, may be different than the loads summarized in Table 3.27.
- (3) Facility Influent – Industrial.
- (4) Calculated by dividing the R/C maximum month load by the R/C average annual load from Table 3.28.
- (5) Calculated by adding the selected industrial load to the selected R/C load.
- (6) Average of the MM values in Table 3.27.
- (7) Greatest R/C load between 2015 and 2020.
- (8) Calculated by dividing the selected R/C load by the selected AA R/C load from table 3.28.

3.4.2.4 Maximum Week BOD₅ Loads

The MW BOD₅ loads are reported in Table 3.30. Between the years 2015 and 2020, the MW peaking factor ranged from 1.42 to 1.80, with the maximum peak factor occurring in the year 2017. To account for the lower peak factors observed in recent years, a slightly lower peak factor of 1.77 was selected as the basis of planning. This peak factor corresponds to the maximum calculated R/C load of 11,970 ppd. The selected MW BOD₅ load of 13,186 ppd was calculated by adding the maximum industrial BOD₅ load to the selected R/C MW BOD₅ load. This selected load is approximately 5 percent greater than the maximum measured MW BOD₅ load of 12,529 ppd measured in the year 2017.

Table 3.30 Maximum Week BOD₅ Loads and Peaking Factors

Data Source	Facility ⁽¹⁾ (ppd)	Industrial ⁽²⁾ (ppd)	R/C ⁽³⁾ (ppd)	R/C Peaking Factor ⁽⁴⁾
2015 DMRs	10,264	1271	8,993	1.51
2016 DMRs	12,141	969	11,172	1.75
2017 DMRs	12,529	559	11,970	1.80
2018 DMRs	10,686	567	10,119	1.60
2019 DMRs	10,105	526	9,579	1.45
2020 DMRs	10,321	852	9,469	1.42
Maximum Value (2015 – 2020)	12,529	1,271	11,970	1.81
Selected Value	13,186⁽⁵⁾	1,216⁽⁶⁾	11,970⁽⁷⁾	1.77⁽⁸⁾

Notes:

- (1) Maximum 7-day running average.
- (2) Equal to 30-day average industrial load occurring at the same time as the maximum 7-day average of the facility influent. Since maximum month industrial loads may not occur at the same time as the maximum week of the facility influent loads, the loads shown here, may be different than the loads summarized in Table 3.27.
- (3) Facility Influent – Industrial.
- (4) Calculated by dividing the R/C maximum week load by the R/C average annual load from Table 3.28.
- (5) Calculated by adding the selected industrial load to the selected R/C load.
- (6) Average of the MM values in Table 3.27.
- (7) Greatest R/C load between 2015 and 2020.
- (8) Calculated by dividing the selected R/C load by the selected AA R/C load from table 3.28.

3.4.2.5 Peak Day BOD₅ Loads

The PD BOD₅ loads are reported in Table 3.31. Between the years 2015 and 2020, the PD peaking factor ranged from 1.51 to 2.73, with the maximum peaking factor occurring in the year 2017. To account for the lower peak factors observed in recent years, a slightly lower peak factor of 2.67 was selected as the basis of planning. This peak factor corresponds to the maximum calculated R/C load of 18,078 ppd. The selected PD BOD₅ load of 19,294 ppd was calculated by adding the maximum industrial BOD₅ load to the selected R/C PD BOD₅ load. This selected load is within 5 percent of the maximum measured PD BOD₅ load of 18,588 ppd measured in the year 2017.

Table 3.31 Peak Day BOD₅ Loads and Peaking Factors

Data Source	Facility ⁽¹⁾ (ppd)	Industrial ⁽²⁾ (ppd)	R/C ⁽³⁾ ppd	R/C Peaking Factor ⁽⁴⁾
2015 DMRs	10,264	1271	8,993	1.51
2016 DMRs	14,389	955	13,434	2.10
2017 DMRs	18,588	510	18,078	2.73
2018 DMRs	12,711	567	12,144	1.92
2019 DMRs	11,483	854	10,629	1.61
2020 DMRs	12,030	613	11,417	1.71
Maximum Value (2015 – 2020)	18,588	1,271	18,078	2.73
Selected Value	19,294⁽⁵⁾	1,216⁽⁶⁾	18,078⁽⁷⁾	2.67⁽⁸⁾

Notes:

- (1) Maximum daily value.
- (2) Equal to 30-day average industrial load occurring at the same time as the maximum day for the facility influent. Since maximum month industrial loads may not occur at the same time as the maximum day facility influent loads, the loads shown here, may be different than the loads summarized in Table 3.27.
- (3) Facility Influent – Industrial.
- (4) Calculated by dividing the R/C maximum daily load by the R/C average annual load from Table 3.28.
- (5) Calculated by adding the selected industrial load to the selected R/C load.
- (6) Average of the MM values in Table 3.27.
- (7) Greatest R/C load between 2015 and 2020.
- (8) Calculated by dividing the selected R/C load by the selected AA R/C load from table 3.28.

3.4.2.6 Summary of BOD₅ Loads

The summary of existing BOD₅ loads is found in Table 3.32.

Table 3.32 BOD₅ Existing Loads Summary

Data Source	Facility (ppd)	Industrial (ppd)	R/C (ppd)	R/C Peaking Factor
Annual Average	7,516	742	6,774	1.00
Maximum Month	10,685	1,216	9,469	1.40
Maximum Week	13,186	1,216	11,970	1.77
Peak Day	19,294	1,216	18,078	2.67

3.4.3 Ammonia

Limited data was available to characterize the ammonia loading at the WWTP. Influent ammonia concentrations were measured from January 2017 through October of 2019 and no data was available on the industrial ammonia concentrations.

This section summarizes the methodology for estimating the industrial ammonia contribution, characterizing historical facility influent ammonia data and R/C ammonia loads. Note that all loads presented in this chapter are presented as pounds of ammonia as nitrogen.

3.4.3.1 Industrial Ammonia Loads

Since no data is available on ammonia contributions from industrial sources, the industrial ammonia loads were assumed to have the same ammonia concentration as was measured at the facility influent. The industrial ammonia loads were estimated on a daily basis between 2017 and 2019 based on the daily measured combined industrial flow and the measured facility influent ammonia concentration. Table 3.33 summarizes the average annual and maximum monthly estimated ammonia loads for these years. The average of the estimated AA and MM industrial ammonia loads were assumed when estimating the current facility influent ammonia loads. Since weekly and daily industrial flows were not available, the estimated MM industrial ammonia load was also assumed for the MW and PD conditions.

Table 3.33 Estimated Annual Average and Maximum Monthly Industrial Ammonia Contributions

Year	AA ammonia load (ppd) ⁽¹⁾	MM ammonia load (ppd) ⁽¹⁾
2015		
2016		
2017	49	79
2018	48	64
2019 ⁽²⁾	46	63
2020		
Average	48	69

Notes:

- (1) Since no data is available on ammonia contributions from industrial sources, the industrial ammonia loads were assumed to have the same ammonia concentration as was measured at the facility influent. Daily industrial ammonia loads were estimated based on the measured influent ammonia concentration and the measured combined industrial load. Loads are presented for the water year (November 1st of the previous calendar year through October 31st).
- (2) Data only available through October of 2019.

3.4.3.2 Average Ammonia Loads

Average annual ammonia loads were reported for the years 2017 through 2019 and are summarized in Table 3.34. Between the years 2017 and 2019, the R/C per capita ammonia load was 0.02 ppd. The selected R/C AA ammonia load was calculated by multiplying the selected per capita load by the 2020 population. The selected AA load was calculated by adding the average industrial load of 48 ppd to the selected R/C AA load.

Table 3.34 Average Annual Ammonia Load

Data Source	Population ⁽¹⁾	Facility ⁽²⁾ (ppd)	Industrial ⁽³⁾ (ppd)	R/C ⁽⁴⁾ (ppd)	R/C Per Capita (ppd) ⁽⁵⁾
2015 DMRs	22,870	–	–	–	–
2016 DMRs	23,740	–	–	–	–
2017 DMRs	24,315	624	49	574	0.02
2018 DMRs	25,250	627	48	579	0.02
2019 DMRs	25,635	603	46	558	0.02
2020 DMRs	25,915	--	--	--	–
Average Value (2017 – 2019)		618	48	570	0.02
Selected Value	25,915⁽⁶⁾	638⁽⁷⁾	48	590⁽⁸⁾	0.02

Notes:

- (1) Certified PSU PRC estimates.
- (2) Direct average loads from influent readings on DMRs, as nitrogen.
- (3) Since no information is available on the ammonia load from the industrial sources, the industrial flow was assumed to have the same ammonia concentration as the influent flow.
- (4) R/C = Facility - Industrial.
- (5) Calculated by dividing the R/C load by the population.
- (6) 2020 population
- (7) Calculated by adding the selected industrial load to the selected R/C load.
- (8) Calculated by multiplying the selected R/C per capita load by the 2020 population.

3.4.3.3 Maximum Month Ammonia Loads

The MM ammonia loads are reported in Table 3.35 and indicate relatively consistent loading. Between the years 2017 and 2019, the MM peaking factor ranged from 1.09 to 1.13, with the maximum peak factor of 1.13 occurring in the years 2018 and 2019. This peaking factor was used as the basis of planning and was multiplied by the selected R/C AA ammonia load to calculate the selected R/C MM ammonia load of 668 ppd. The selected MM load of 728 ppd was calculated by adding the maximum industrial ammonia load to the selected R/C MM ammonia load. This selected load is within five percent of the maximum measured MM ammonia load of 688 ppd measured in the year 2018.

Table 3.35 Maximum Month Ammonia Loads and Peaking Factors

Data Source	Facility ⁽¹⁾ (ppd)	Industrial ⁽²⁾ (ppd)	R/C ⁽³⁾ (ppd)	R/C Peaking Factor ⁽⁴⁾
2015 DMRs	--	--	--	--
2016 DMRs	--	--	--	--
2017 DMRs	685	60	625	1.09
2018 DMRs	695	39	656	1.13
2019 DMRs	688	60	627	1.13
2020 DMRs	--	--	--	--
Maximum Value (2017 – 2019)	695	60	656	1.13
Selected Value	725⁽⁵⁾	69⁽⁶⁾	656	1.11⁽⁷⁾

Notes:

- (1) Maximum 30-day average loads from influent readings on DMRs, as nitrogen.
- (2) Since no information is available on the ammonia load from the industrial sources, the industrial flow was assumed to have the same ammonia concentration as the influent flow. Estimated industrial load for the month corresponding to the facility influent maximum month.
- (3) R/C = Facility - Industrial.
- (4) Calculated by dividing the maximum month R/C load by the average annual R/C load from Table 3.34.
- (5) Calculated by adding the selected industrial load to the selected R/C load.
- (6) Selected value equals the average estimated MM industrial load from Table 3.33.
- (7) Calculated by dividing the selected R/C MM ammonia load by the selected R/C AA ammonia load from Table 3.34.

3.4.3.4 Maximum Week Ammonia Loads

The MW ammonia loads are reported in Table 3.36. Between the years 2017 and 2019, the MW peaking factor ranged from 1.22 to 1.46, with the maximum peak factor of 1.46 occurring in the year 2017. If this peaking factor were used as the basis of planning, the resultant facility influent MW ammonia load would be approximately 7 percent higher than the maximum measured MW load. So as to not have an overly conservative projected maximum week ammonia load, a slightly lower MW peaking factor of 1.42 was selected. This peak factor correlates to the maximum calculated R/C load of 839 ppd. The selected MW load of 919 ppd was calculated by adding the maximum industrial ammonia load to the selected R/C MW ammonia load. This selected load is approximately five percent greater than the measured MW ammonia load of 875 ppd measured in the year 2019.

Table 3.36 Maximum Week Ammonia Loads and Peaking Factors

Data Source	Facility ⁽¹⁾ (ppd)	Industrial ⁽²⁾ (ppd)	R/C ⁽³⁾ (ppd)	R/C Peaking Factor ⁽⁴⁾
2015 DMRs	–	–	–	–
2016 DMRs	–	–	–	–
2017 DMRs	874	35	839	1.46
2018 DMRs	788	79	708	1.22
2019 DMRs	875	81	794	1.42
2020 DMRs	–	--	--	--
Maximum Value (2017 – 2019)	875	81	839	1.46
Selected Value	919⁽⁵⁾	81	839	1.42⁽⁶⁾

Notes:

- (1) Maximum 7-day average loads from influent readings on DMRs, as nitrogen.
- (2) Since no information is available on the ammonia load from the industrial sources, the industrial flow was assumed to have the same ammonia concentration as the influent flow. Estimated industrial load for the week corresponding to the facility influent maximum week.
- (3) R/C = Facility - Industrial.
- (4) Calculated by dividing the maximum week R/C load by the average annual R/C load from Table 3.33.
- (5) Calculated by adding the selected industrial load to the selected R/C load.
- (6) Calculated by dividing the selected R/C MW ammonia load by the selected R/C AA ammonia load from Table 3.33.

3.4.3.5 Peak Day Ammonia Loads

The PD ammonia loads are reported in Table 3.37. Between the years 2017 and 2019, the PD peaking factor ranged from 1.33 to 2.10, with the maximum peak factor of 2.10 occurring in the year 2017. If this peaking factor were used as the basis of planning, the resultant facility influent PD ammonia load would be approximately 7 percent higher than the maximum measured PD load. So as to not have an overly conservative projected peak day ammonia load, a slightly lower PD peaking factor of 2.04 was selected. This peak factor correlates to the maximum calculated R/C load of 1,202 ppd. The selected PD load of 1,289 ppd was calculated by adding the maximum industrial ammonia load to the selected R/C PD ammonia load. This selected load is within 5 percent of the maximum measured PD ammonia load of 1,244 ppd measured in the year 2017.

Table 3.37 Peak Day Ammonia Loads and Peaking Factors

Data Source	Facility ⁽¹⁾ (ppd)	Industrial ⁽²⁾ (ppd)	R/C ⁽³⁾ (ppd)	R/C Peaking Factor
2015 DMRs	–	–	–	–
2016 DMRs	–	–	–	–
2017 DMRs	1,244	42	1,202	2.10
2018 DMRs	805	33	772	1.33
2019 DMRs	963	87	892	1.60
2020 DMRs	--	--	--	--
Maximum Value (2017 – 2020)	1,244	87	1,202	2.10
Selected Value	1,289	87	1,202	2.04

Notes:

- (1) Maximum daily average loads from influent readings on DMRs, as nitrogen.
- (2) Since no information is available on the ammonia load from the industrial sources, the industrial flow was assumed to have the same ammonia concentration as the influent flow. Estimated industrial load for the day corresponding to the facility influent maximum day.
- (3) R/C = Facility - Industrial.
- (4) Calculated by dividing the peak daily R/C load by the average annual R/C load from Table 3.33.
- (5) Calculated by adding the selected industrial load to the selected R/C load.
- (6) Calculated by dividing the selected R/C PD ammonia load by the selected R/C AA ammonia load from Table 3.33.

3.4.3.6 Summary of Ammonia Loads

The summary of existing ammonia loads is found in Table 3.38.

Table 3.38 Ammonia Existing Loads Summary

Data Source	Facility (ppd)	Industrial (ppd)	R/C (ppd)	R/C Peaking Factor
Annual Average	638	48	590	1.00
Maximum Month	725	69	656	1.11
Maximum Week	907	69	839	1.42
Peak Day	1,302	69	1,233	2.09

3.4.4 Phosphorous

Influent TP concentrations were not available on the supplied DMRs. TP concentrations can be estimated as a fraction of BOD₅ concentration. Table 3.18 of Metcalf & Eddy Fifth Edition lists TP concentrations as 2.8 percent of BOD₅ concentrations in typical domestic wastewater. This fraction was used to prepare the following estimated TP (Table 3.39) loading.

Table 3.39 Estimate of Existing Total Phosphorous Loads

Data Source	Facility (ppd)	Industrial (ppd)	R/C (ppd)	R/C Peaking Factor
Annual Average	209	21	188	1.00
Maximum Month	297	34	263	1.40
Maximum Week	366	34	332	1.77
Peak Day	536	34	502	2.67

3.5 Load Projections

Load projections were developed by adding the projected industrial load to the projected R/C loads. This section documents the industrial load projections along with the projections for the R/C and combined loads.

3.5.1 Industrial Load Projection

As was discussed in Section 3.3.1, industrial flows for the City's current SIUs are assumed to grow to the current permitted maximum flow capacity by the year 2045. Year 2045 loads were calculated for each industry assuming that they stay at their current strength, and thus loads were assumed to increase proportional to the projected flow increase. The following describes how TSS and BOD₅ loads were projected for each of the current SIUs.

- **Current AA loads for each SIU:** Current AA industrial loads from each SIU were calculated from the reported monthly data.
- **Current MM loads for each SIU:** Since the MM for each industry typically does not occur at the same time, current MM loads for each SIU were calculated by multiplying each SIUs proportion of the current AA load by the selected current MM industrial load (Table 3.20 for TSS and 3.26 for BOD₅).
- **2045 AA and MM loads for each of the current SIUs:** Since only one industry has a permitted maximum load, the AA TSS and BOD₅ concentrations for each SIU were assumed to remain at current concentrations. The projected increase 2045 AA and MM loads for each SIU was then assumed to be proportional to the expected increase in flow for each SIU (Table 3.17). These projected loads were then checked against permitted loads and held at the permitted loads if the projection exceeded the permitted value.

The methodology used to project the TSS and BOD₅ loads from the current SIUs is shown in more detail in Tables 3.40 and 3.41 for TSS and BOD₅, respectively. As is shown in Table 3.39, the majority of the current industrial TSS load comes from ODOC which has the smallest potential for growth. Due to this limitation, the industrial TSS load from the current SIUs is only projected to increase by 163 percent. Both ODOC and Swire split the current industrial BOD₅ load. While Swire has a greater growth potential for flow, this SIUs growth potential for BOD₅ is limited by

the permit issued by the City. For this reason, the overall industrial BOD₅ load growth is expected to be very similar to the potential growth in industrial TSS load.

In addition to the current areas zones for industrial use, the CSMP (2014) projects that 1,220 acres within the UGB could be zoned for industrial areas by the year 2045. The projected 2045 BOD₅ and TSS AA and MM loads from these new areas was projected assuming that the new industries have the same AA and MM concentration as the current SIUs.

The projected 2045 permitted industrial TSS and BOD₅ loads are the sum of the loads projected for the current industrial area and the areas within the UGB that could be zoned for industrial uses in the future. These loads are summarized in Tables 3.42 and 3.43 for TSS and BOD₅, respectively. By using this methodology, the industrial TSS and BOD₅ load is projected to grow by 319 percent through the year 2045 which is slightly less than the projected increase in industrial flow of 460 percent.

Since the loads associated with the non-permitted industrial sources are not tracked, this load is part of the calculated R/C load and is assumed to grow with the residential population.

Table 3.40 Industrial TSS Load Projections for Permitted Industrial Users within the Current Industrial Area

Item	Current AA TSS (ppd)	Percent of Current AA Load	Calculated Current MM TSS (ppd) ⁽¹⁾	Permitted maximum load (ppd)	Growth Potential ⁽²⁾	Selected 2045 AA TSS (ppd) ⁽³⁾	Selected 2045 MM TSS (ppd) ⁽⁴⁾
Swire	24	6%	37	NA	254%	60	93
ODOC	370	89%	573	NA	153%	566	878
Fujimi	4	1%	6	NA	776%	29	45
Xerox	0	0%	0	NA	1095%	2	3
Flir	0	0%	0	NA	4527%	1	2
Sysco	17	4%	26	NA	NA	17	26
Total	414		642		163%	675	1,046

Notes:

- (1) Since the MMs of each SIU do not necessarily occur at the same time, the MM load for each SIU was calculated by multiplying each SIUs percent of current AA load by the selected current SIU MM load from Table 3.20.
- (2) Growth potential was set equal to the calculated growth potential for flow as shown in Table 3.17.
- (3) Calculated by multiplying the selected MM load for each SIU by the ratio of the current total SIU AAF to MMF from Table 3.20.
- (4) Selected MM load for each SIU equals the calculated current MM load multiplied by the growth potential.

Table 3.41 Industrial BOD₅ Load Projections for Permitted Industrial Users within the Current Industrial Area

Item	Current AA BOD ₅ (ppd)	Percent of Current AA Load	Calculated Current MM BOD ₅ (ppd) ⁽¹⁾	Permitted maximum load (ppd)	Growth Potential ⁽²⁾	Selected 2045 AA BOD ₅ (ppd) ⁽³⁾	Selected 2045 MM BOD ₅ (ppd) ⁽⁴⁾
Swire	367	49%	602	1,000	254%	932	1,000
ODOC	353	48%	579	NA	153%	540	886
Fujimi	6	1%	9	NA	776%	45	73
Xerox	0	0%	0	NA	1095%	2	3
Flir	0	0%	0	NA	4527%	2	3
Sysco	16	2%	26	NA	NA	16	26
Total	742		1,216		164%⁽⁵⁾	1,536	1,991

Notes:

- (1) Since the MMs of each SIU do not necessarily occur at the same time, the MM load for each SIU was calculated by multiplying each SIUs percent of current AA load by the selected current SIU MM load from Table 3.26.
- (2) Growth potential was set equal to the calculated growth potential for flow as shown in Table 3.17. Permitted maximum loads may reduce this potential.
- (3) Calculated by multiplying the selected MM load for each SIU by the ratio of the current total SIU AAF to MMF from Table 3.26.
- (4) Selected MM load for each SIU equals the calculated current MM load multiplied by the growth potential.
- (5) Calculated by dividing the total selected 2045 MM BOD₅ load by the total calculated current MM BOD₅ load.

Table 3.42 Industrial TSS Load Projections

	Current Industrial Area	New Industrial Area	Combined Industry
2020			
AA TSS, ppd	414 ⁽¹⁾		414
AA TSS, mg/L	292 ⁽²⁾		292
MM TSS, ppd	642 ⁽¹⁾		642
MM TSS, mg/L	405 ⁽²⁾		405
2045			
AA TSS, ppd	675 ⁽¹⁾	646 ⁽³⁾	1,322 ⁽⁴⁾
AA TSS, mg/L	157 ⁽⁵⁾	292 ⁽⁶⁾	203 ⁽⁷⁾
MM TSS, ppd	1,046 ⁽¹⁾	1,002 ⁽³⁾	2,049 ⁽⁴⁾
MM TSS, mg/L	218 ⁽⁵⁾	405 ⁽⁶⁾	281 ⁽⁷⁾

Notes:

- (1) From Table 3.39.
- (2) Calculated by dividing the current load by the selected current industrial flow from Table 3.2.
- (3) Calculated by multiplying the selected TSS concentration for the new industrial areas by the selected flow for the new industrial areas (Table 3.18).
- (4) Calculated as the sum of the load from the current industrial area and the new industrial area.
- (5) Calculated by dividing the projected 2045 load by the selected 2045 flow for the current industries (Table 3.17).
- (6) Conservatively assumed to equal the calculated 2020 concentration for the current industrial area.
- (7) Calculated by dividing the combined industrial load by the combined industrial flow from Table 3.18.

Table 3.43 Industrial BOD₅ Load Projections

	Current Industrial Area	New Industrial Area	Combined Industry
2020			
AA BOD ₅ , ppd	742 ⁽¹⁾		742
AA BOD ₅ , mg/L	523 ⁽²⁾		523
MM BOD ₅ , ppd	1,216 ⁽¹⁾		1,216
MM BOD ₅ , mg/L	767 ⁽²⁾		767
2045			
AA BOD ₅ , ppd	1,536 ⁽¹⁾	1,159 ⁽³⁾	2,695 ⁽⁴⁾
AA BOD ₅ , mg/L	357 ⁽⁵⁾	523 ⁽⁶⁾	413 ⁽⁷⁾
MM BOD ₅ , ppd	1,991 ⁽¹⁾	1,899 ⁽³⁾	3,890 ⁽⁴⁾
MM BOD ₅ , mg/L	414 ⁽⁵⁾	767 ⁽⁶⁾	534 ⁽⁷⁾

Notes:

- (1) From Table 3.40.
- (2) Calculated by dividing the current load by the selected current industrial flow from Table 3.2.
- (3) Calculated by multiplying the selected BOD₅ concentration for the new industrial areas by the selected flow for the new industrial areas (Table 3.18).
- (4) Calculated as the sum of the load from the current industrial area and the new industrial area.
- (5) Calculated by dividing the projected 2045 load by the selected 2045 flow for the current industries (Table 3.17).
- (6) Conservatively assumed to equal the calculated 2020 concentration for the current industrial area.
- (7) Calculated by dividing the combined industrial load by the combined industrial flow from Table 3.18.

Since no data is available for industrial ammonia or TP concentrations, these parameters were projected using a different methodology from TSS and BOD₅. The 2045 AA industrial ammonia concentration was assumed to be equal to the current influent ammonia concentration. The projected 2045 MM ammonia load was then calculated by multiplying the projected AA ammonia load by the ratio of the selected current MM industrial ammonia load to the current AA industrial ammonia load (Table 3.32). Since no data is available for either the industrial or the facility influent TP concentration, the industrial TP load was assumed to equal 2.8 percent of the industrial BOD load. This percentage was selected because it represents a typical ratio of TP to BOD₅ for domestic wastewater (Table 3.18 from Metcalf and Eddy 5th Edition).

Table 3.44 summarizes the projected 2045 industrial loads.

Table 3.44 2045 Industrial Load Summary

Data Source	TSS (ppd)	BOD ₅ (ppd)	Ammonia (ppd)	TP (ppd)
Annual Average	1,322 ⁽¹⁾	2,695 ⁽²⁾	224 ⁽³⁾	75 ⁽⁴⁾
Maximum Month	2,049 ⁽¹⁾	3,890 ⁽²⁾	323 ⁽⁵⁾	108 ⁽⁴⁾
Maximum Week ⁽⁶⁾	2,049	3,890	323	108
Peak Day ⁽⁶⁾	2,049	3,890	323	108

Notes:

- (1) From Table 3.42.
- (2) From Table 3.43.
- (3) Calculated by multiplying the selected 2045 AA industrial flow by the current AA facility influent ammonia concentration. The current AA facility influent ammonia concentration was calculated by dividing the selected current AA ammonia load (Table 3.34) by the selected current facility influent AAF (Table 3.4).
- (4) Calculated by multiplying the industrial loads by 2.8% (from Table 3.18 of Metcalf and Eddy 5th edition).
- (5) Calculated by multiplying the 2045 AA industrial ammonia load by the ratio of the selected current MM industrial ammonia load (Table 3.33) to the selected current AA industrial ammonia load (Table 3.33).
- (6) Assumed equal to the maximum month industrial loads.

3.5.2 Total Influent Load Projection

Influent loads were developed by adding the projected 2045 industrial loads to the projected R/C loads. The AA R/C loads for TSS, BOD₅ and ammonia were developed by multiplying the selected per capita load (Tables 3.22, 3.28 and 3.34 for TSS, BOD₅, and ammonia respectively) by the projected 2045 population. The MM, MW and PD R/C loads for TSS, BOD₅ and ammonia were developed by multiplying the selected peaking factors (Tables 3.26, 3.32 and 3.38 for TSS, BOD and ammonia respectively) by the projected AA load. TP loads were assumed to equal 2.8 percent of the projected BOD₅ loads as discussed above. These loads are summarized in Table 3.45.

Table 3.45 Load Projections for the year 2045

Load Parameters	2045 R/C (ppd)	2045 Industrial (ppd)	2045 Facility (ppd)
AA BOD ₅	13,171	2695	15,865
MM BOD ₅	18,411	3890	22,301
MW BOD ₅	23,274	3890	27,163
PD BOD ₅	35,151	3890	39,041
AA TSS	11,780	1,322	13,101
MM TSS	16,068	2,049	18,116
MW TSS	20,475	2,049	22,524
PD TSS	26,833	2,049	28,882
AA ammonia	1,147	224	1,372
MM ammonia	1,275	323	1,598
MW ammonia	1,631	323	1,953
PD ammonia	2,398	323	2,721
AA TP	366	75	441
MM TP	511	108	619
MW TP	646	108	754
PD TP	976	108	1,084

Chapter 4

CAPACITY ANALYSIS

4.1 Introduction

This chapter identifies existing capacity ratings and deficiencies for the liquid and solids stream treatment processes at the City WWTP. Analyses are based on current operational practices and effluent limits required by the WWTP's National Pollutant Discharge Elimination System (NPDES) permit. Biological process modeling was performed using BioWin 6.2 to predict plant performance under current and future flows and loads and evaluate the timing of unit process capacity exceedance within the planning period (present through 2045). Alternatives to address identified capacity limitations and achieve compliance with potential future effluent limits are evaluated in Chapter 6. Recommendations for improving systems that support major unit processes (e.g., aeration blowers, solids pumps, chemical systems) are also included in the discussion of alternatives evaluation (Chapter 6).

4.2 Design Criteria

Design criteria recommended for the Wilsonville WWTP are summarized in Table 4.1 and elaborated upon for each unit process in Section 4.3. The design criteria were established from the following sources:

- 2015-2020 WWTP operations data.
- 1971 Phase 1 WWTP Record Drawings.
- 1979 Phase 3 WWTP Expansion Record Drawings.
- 2012 WWTP Improvements Project Documents.
- 2018 Outfall Replacement Record Drawings.
- 2019 Aeration Basin Improvements Record Drawings.
- NPDES Permit.
- Discussion with City and WWTP operations staff.
- *Preparing Wastewater Planning Documents and Environmental Reports for Public Utilities* by Oregon Department of Environmental Quality et al., rev. 2019.

Table 4.1 Unit Process Capacity Summary

Unit Process	Design Parameter	Redundancy Criteria	Design Criteria	Plant Loadings		Year of Capacity Exceedance	Notes
				Current (2020)	Future (2045)		
Influent Screening	<ul style="list-style-type: none"> PHF 	<ul style="list-style-type: none"> One mechanical screen out of service 	<ul style="list-style-type: none"> 2 x 8 mgd (mechanical) 1 x 16 mgd (manual) 	8.8 mgd	17.6 mgd	>2045	<ul style="list-style-type: none"> 3/8-inch bar spacing. 1-inch bar spacing.
Grit Chamber	<ul style="list-style-type: none"> PHF 	<ul style="list-style-type: none"> All units in service 	<ul style="list-style-type: none"> Hydraulically pass flow (17.6 mgd) 	8.8 mgd	17.6 mgd	2045	<ul style="list-style-type: none"> 12 ft diameter vortex grit removal process Performance is anticipated to be poor when the flow exceeds 8 mgd.
Aeration / Stabilization Basins	<ul style="list-style-type: none"> MW MLSS inventory at PDF MM MLSS inventory at PDF ADW MLSS inventory at PDDWF ADW MLSS inventory at PDDWF ADW MLSS inventory at PDDWF 	<ul style="list-style-type: none"> All units in service All units in service One AB unit out of service One stabilization basin out of service One clarifier out of service 	<ul style="list-style-type: none"> 5-day total SRT 6-day total SRT 6-day total SRT 6-day total SRT 6-day total SRT 	5.6 days	1.8 days	2027	<ul style="list-style-type: none"> Aeration Basin Anoxic Volume = 78,550 gallons, each. Aeration Basin Aerobic Volume = 314,150 gallons, each. Stabilization Basin Aerobic Volume = 168,300 gallons, each.
Secondary Clarifiers	<ul style="list-style-type: none"> PHF SOR MMDWF SOR 	<ul style="list-style-type: none"> All units in service Largest unit out of service 	<ul style="list-style-type: none"> 1386 gpd/sf 1386 gpd/sf 	761 gpd/sf	1,484 gpd/sf	2041	<ul style="list-style-type: none"> Based on an SVI of 150 mL/g; Vo of 21.31 ft/hr; k of 0.403 L/g.-
Secondary Effluent Cooling Towers	<ul style="list-style-type: none"> June 1 - Sept 30 PDF 	<ul style="list-style-type: none"> All units in service 	4.0 mgd	2.3 mgd	4.9 mgd	2036	<ul style="list-style-type: none"> Design ambient wet bulb temperature = 68 °F. Heat Transfer Capacity = 300 tons of refrigerant each.
Disk Filters	<ul style="list-style-type: none"> PDDWF MMDWF 	<ul style="list-style-type: none"> All units in service One unit out of service 	<ul style="list-style-type: none"> 7.5 mgd 3.75 mgd 	3.6 mgd	7.6 mgd	2044	<ul style="list-style-type: none"> Net Effective Filtration Area = 808 sf each.
UV Disinfection Channels	<ul style="list-style-type: none"> PHF PDDWF 	<ul style="list-style-type: none"> All units in service One unit out of service 	<ul style="list-style-type: none"> 16 mgd 8 mgd 	8.8 mgd	17.6 mgd	2041	<ul style="list-style-type: none"> Avg. UVT = 65%, Peak Flow UVT = 55%. Channel 1 = 25 MW-s/cm², Channel 2 = 30 MW-s/cm².
Outfall	<ul style="list-style-type: none"> PHF 	-	19.3 mgd	8.8 mgd	17.6 mgd	>2045	
Gravity Belt Thickening	<ul style="list-style-type: none"> MW Load 	<ul style="list-style-type: none"> One unit out of service 	<ul style="list-style-type: none"> 300 gpm 900 lb/hr 	140 gpm	174 gpm	>2045	<ul style="list-style-type: none"> 24 hours per day, 7 days per week. Assume TWAS at 4% TS, 95% solids capture.
Dewatering Centrifuges	<ul style="list-style-type: none"> MW Load 	<ul style="list-style-type: none"> One unit out of service 	<ul style="list-style-type: none"> 50 gpm 1,000 lb/hr 	20 gpm	45 gpm	>2045	<ul style="list-style-type: none"> 24 hours per day, 7 days per week. Assume dewatered cake at 20% TS, 90% solids capture.
Biosolids Dryer	<ul style="list-style-type: none"> MW Load 	<ul style="list-style-type: none"> All units in service 	<ul style="list-style-type: none"> 3,600 lb/hr 17 dry cy/day 	1,510 lb/hr	3,190 lb/hr	>2045	<ul style="list-style-type: none"> 24 hours per day, 7 days per week. Assume dried solids at 92% TS.

Notes:

Abbreviations: °F – degree(s) Fahrenheit; ADW – average dry weather; BOD – biochemical oxygen demand; cy – cubic yards; ft/hr - feet per hour; gpd – gallons per day; gpm – gallons per minute; hr – hour; lb – pound(s); L/g - liters per gram; mg/L – milligram(s) per liter; MLR – mixed liquor recycle; MLSS – mixed liquor suspended solids; PDF – peak hour flow; psi – pound(s) per square inch; s/cm² – square centimeter per second; scfm – standard cubic foot/feet per minute; sf – square feet; SOR – surface overflow rate; SRT – solids retention time; TDH – total dynamic head; TWAS – thickened waste activated sludge; UVT - ultraviolet transmissivity.

4.3 Unit Process Capacity

This section describes each unit process and its design criteria to establish the unit process capacity. For reference, process schematics and simplified design criteria for each unit process are shown in Appendix G. Each unit process capacity described is compared to the current and projected flows and loads as obtained from Chapter 3 – Wastewater Flow and Loads Projections, as well as the associated BioWin model output (where appropriate). Generally, except where noted otherwise, when the current and projected loads exceed the capacity criteria for each unit process, expansion or modification of that process may be needed, providing the framework for identifying process upgrade alternatives to be described in Chapter 6 - Alternatives Development and Evaluation.

4.3.1 Preliminary Treatment

Sewage enters the WWTP through gravity influent lines into the headworks structure, constructed as part of the 2012 WWTP Improvements project. The onsite septage receiving station also discharges to the headworks using a sump pump. Preliminary treatment consists of screening and grit removal. A schematic illustrating the preliminary treatment process, including ancillary processes not evaluated as part of this Chapter, is shown in Figure G.1 of Appendix G.

4.3.1.1 Screening

Raw sewage is split between two mechanically raked bar screens, each with 3/8-inch openings between the bars. The design criteria for the screens are as follows:

- Each screen is rated to accommodate 8 mgd, per the design criteria provided in the 2012 WWTP Improvements project documents.
- If one of these screens is out of service and additional screening capacity is necessary, the raw sewage can flow through a bypass channel containing a manual bar rack with one-inch openings between the bars.
- The bypass channel is rated for 16 mgd, per the design criteria provided in the 2012 WWTP Improvements project documents.

As illustrated in Figure 4.1, the projected PHF is 17.6 mgd by the year 2045. If both mechanical screens were in operation at this time, an additional 1.6 mgd would need to be routed through the bypass channel and the manual bar rack. If one of the mechanical screens were out of service during this PHF, 8 mgd could pass through the mechanical bar screens and 9.6 mgd would need to be routed through the bypass channel and the manual bar rack. Based on this continued use of the mechanical bar screens and bypass channel with the manual bar rack, there is sufficient process capacity for the bar screens to accommodate the projected 2045 PHF. Hydraulic modeling conducted by Jacobs (*Hydraulic Analysis* TM, August 31, 2023) (Appendix H) indicates that hydraulically the influent screening can pass the projected PHF of 17.6 mgd.

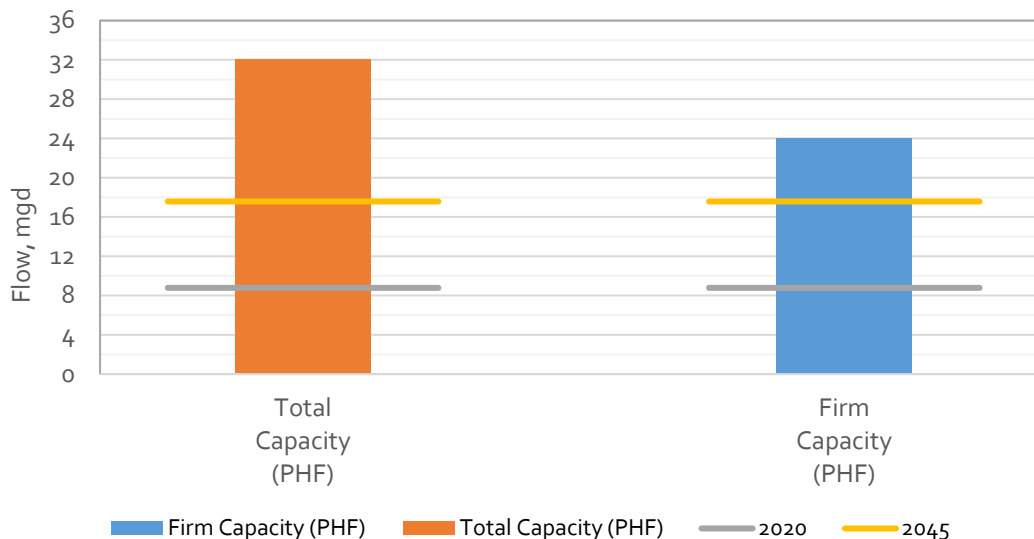

Figure 4.1 Mechanical Screening Capacity

Note: With either mechanical screen out of service, the remaining unit does not have sufficient (firm) capacity to handle projected peak hour flows. In these instances, the manual bar rack provides necessary capacity.

Grit Removal

Downstream of the influent screens, grit is removed from the sewage via a vortex grit removal process that can be bypassed for maintenance purposes. The 2012 WWTP Improvement documents indicate a design capacity of 16 mgd for the vortex grit basin. Although this capacity is consistent with the design criteria of the 2012 WWTP Improvement documents, the drawings show a 12-foot diameter grit removal process. For a 12-foot diameter vortex grit removal process, the manufacturers rated capacity would typically be 12 mgd. Carollo's experience with these types of vortex grit removal systems suggests that they have a better chance of meeting the manufacturer targeted removals when peak flows decrease by 30 to 40 percent below the rated capacity. For a 12-foot diameter grit removal process, this would equate to a flow of approximately 8 mgd. However, the actual performance of the grit removal process will depend on the particle size distribution of the grit. If the influent has a high percentage of large size grit particles, the current grit removal process will perform better than anticipated. Hydraulic modeling conducted by Jacobs (*Hydraulic Analysis* TM, August 31, 2023) (Appendix H) indicates that hydraulically, the grit removal system can pass a PHF of 17.6 mgd. At this flow rate the anticipated performance would be poor.

The plant has seen PHFs above 8 mgd and PHFs are projected to more than double by the year 2045. Additionally, the PHF is anticipated to increase above a typical manufacturer rated capacity for a 12 foot diameter unit by the year 2030. Based on discussions with the City, poor performance under PHF conditions is acceptable as long as the system can hydraulically pass the flow. As is shown in Figure 4.2, purely based on the hydraulic capacity, the grit removal system should have sufficient capacity through the year 2045.

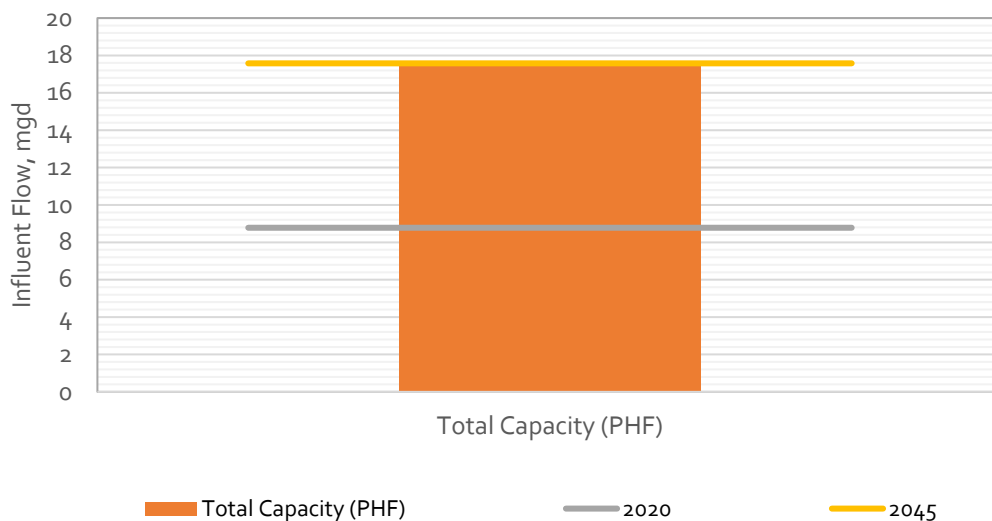

Figure 4.2 Grit Removal Capacity

4.3.2 Secondary Treatment

4.3.2.1 Background

Following preliminary treatment, screened and dewatered wastewater flows to the secondary treatment process. A schematic illustrating the secondary treatment process is shown in Figure G.2 of Appendix G.

The WWTP has three similarly sized aeration basins. The first two were constructed in the 1970s, while the third was constructed in 2012 as an expansion to the existing process. Each tank is 175 feet long, 20 feet wide, and 15 feet deep. Each basin is divided into four zones by baffle walls, with the first zone being unaerated. Although the final sections of the aeration basins contain two distinct diffuser grids, referred to on the drawings as “Zone 4” and “Zone 5”, there is no baffle wall separating the two zones. The unaerated zones are mixed via large bubble forming plates that agitate the mixed liquor with minimal oxygen transfer. These bubbles are generated from dedicated air compressors and do not require supplemental aeration blower capacity to provide mixing.

The basins were modified in 2020 to provide MLR pumping from the final aerated zone to the first zone in each basin, allowing for the operation of a Modified Ludzack-Ettinger process. Each basin is equipped with its own dedicated submersible, axial-flow MLR pump and variable frequency drive (VFD) to allow for modulation of the MLR flow rate based on maintaining an operator set point ratio of MLR flow to influent flow. These modifications also reduced the unaerated volume in the aeration basins by approximately 50 percent to 79,000 gallons each, with the remaining aerated volume representing approximately 314,000 gallons per basin.

Mixed liquor from the end of the aeration basins recombines in an effluent channel and is then split between three 70-foot diameter secondary clarifiers. Each clarifier has a sidewater depth of 16 feet. RAS is withdrawn from the underside of each secondary clarifier to one of four RAS pumps. Each of the RAS pumps is equipped with a 20-horsepower motor and a VFD, and the pump speed is modulated to control the sludge blanket depth. These pumps return activated sludge to the stabilization basin.

The stabilization basins contain RAS that has not yet been returned to the aeration basins. This operating configuration, called contact stabilization, allows for the accumulation of the aeration basin inventory at the front end of the basin. Since the stabilization basin is aerated, this mode of operation increases the aerobic solids retention time (aSRT), which provides stable nitrification at a reduced basin volume. (Note that the WWTP operations staff uses total SRT instead of aSRT, so total SRT is presented throughout this chapter except when describing calibration of the BioWin model). There is also capacity to divert a portion of the influent flow to the stabilization basins, allowing for step feed operation. Step feed operation was most recently used during the aeration basin modification project's construction.

Lastly, air for the aeration and stabilization basins is provided by six 1,700 scfm blowers. Three of these are older, constant speed multistage centrifugal blowers, while the other three are single stage high-speed turbo blowers with adjustable speed, installed as part of the 2012 plant upgrades.

4.3.2.2 Historical Performance

Historical SRT is presented in Figure 4.3. Operations staff has historically run the secondary treatment process at a long SRT, typically 10-15 days. This was done to minimize the solids load to the dryer and address poor BOD removal when the SRT was reduced. However, the recent modifications to the aeration basins have allowed operations staff to reduce SRT significantly, with stable secondary treatment performance observed at an SRT of only six days.

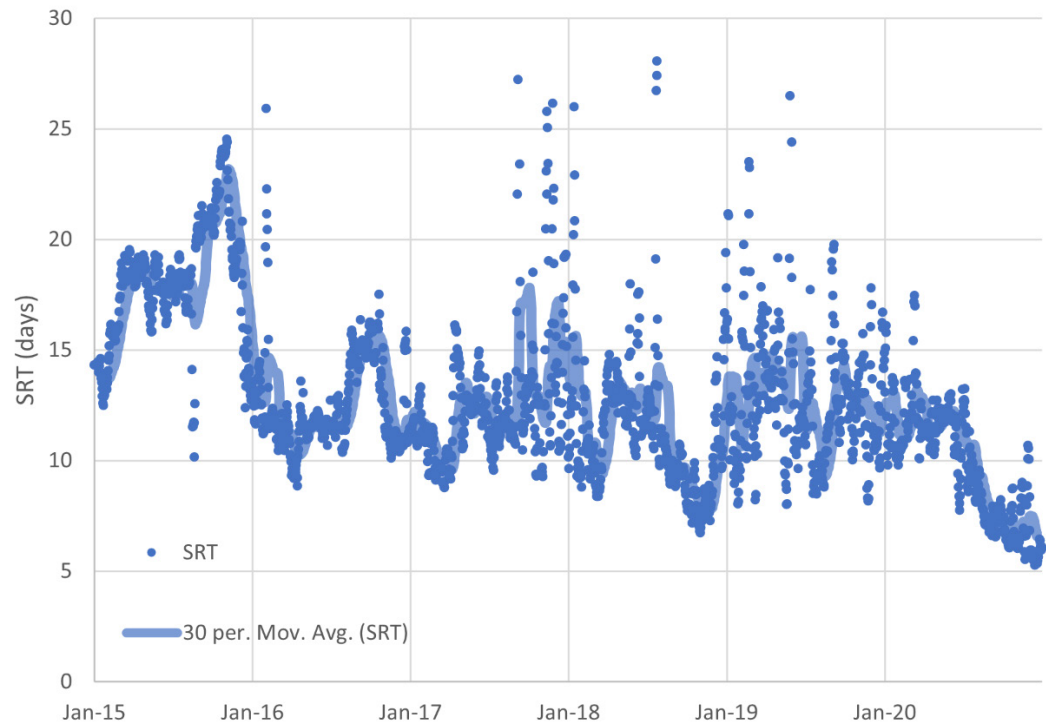

Figure 4.3 Historical Solids Retention Time

The historical MLSS concentration in the aeration basins is shown in Figure 4.4. In general, SRT and MLSS concentration trend in the same direction except for in 2020, when aeration basins were shut down in sequence as part of the installation of the 2019 Aeration Basin Improvements Project. This modification resulted in a significant increase in MLSS without any corresponding increase in SRT.

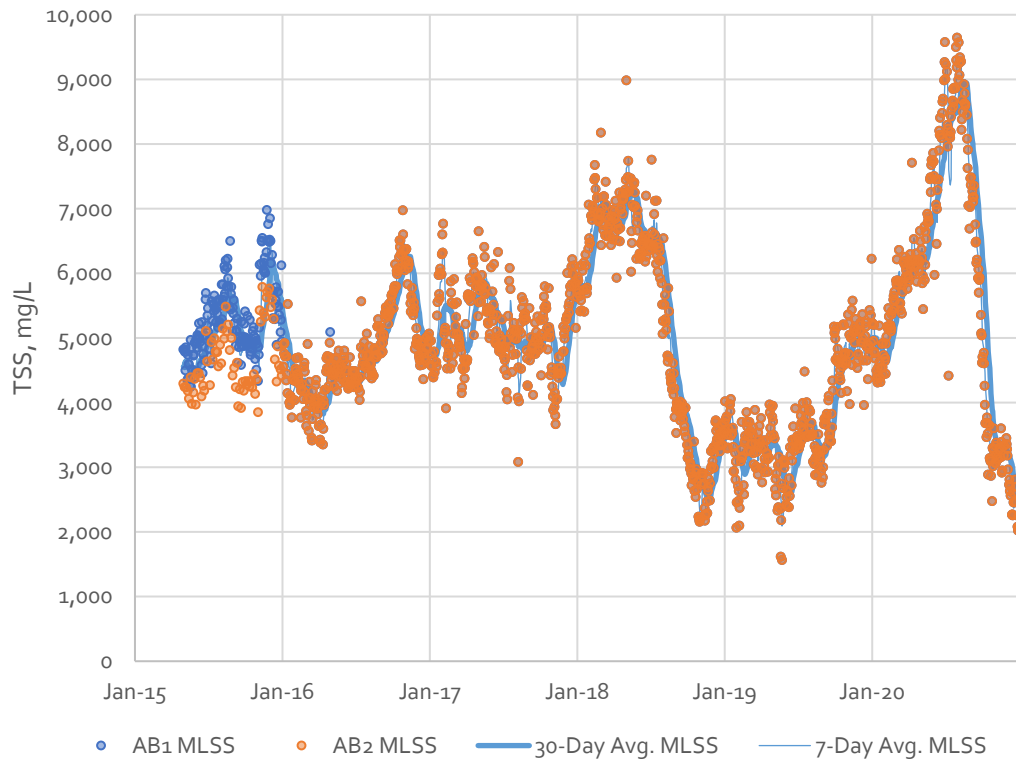

Figure 4.4 Historical Aeration Basin Mixed Liquor Suspended Solids

Effluent ammonia concentrations are typically low, as shown in Figure 4.5, indicating that the plant is fully nitrifying and has created conditions favorable for the growth of nitrifying organisms. This is typical for plants operating at long SRTs. Nitrification significantly increases the oxygen consumed in the secondary treatment process. Since there are currently no permit limits associated with effluent ammonia, nor are there expected to be any new limits imposed during the planning period as described in Chapter 5 - Regulatory Considerations and Strategy, nitrification is not necessary to meet the NPDES permit requirements.

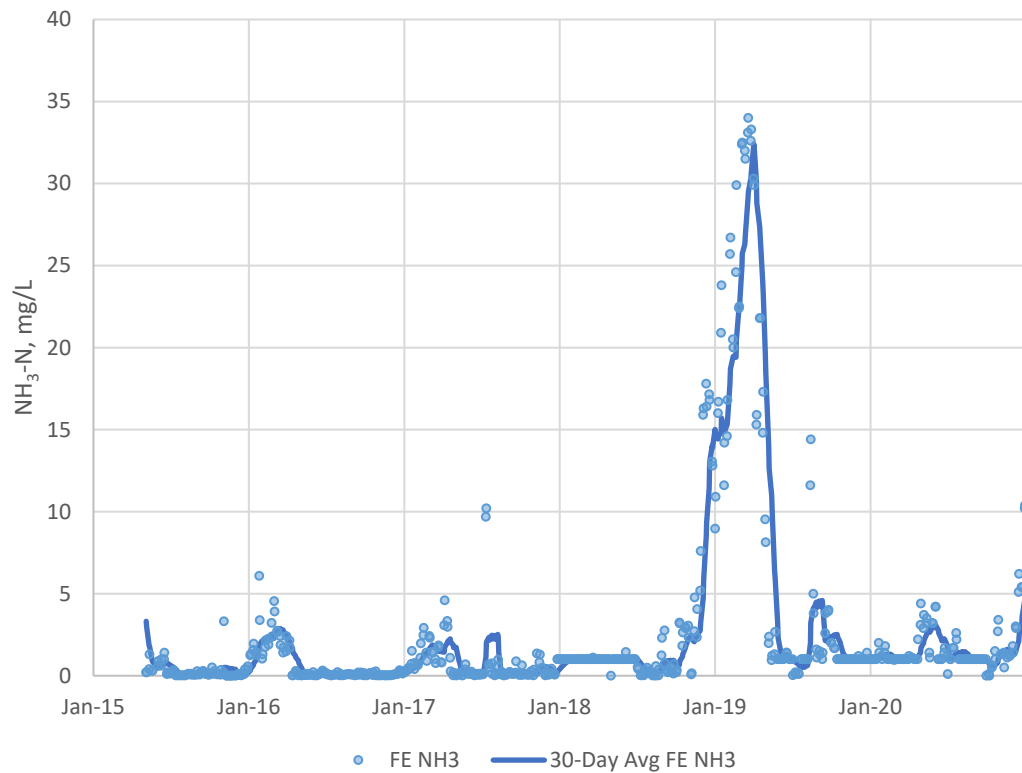

Figure 4.5 Historical Final Effluent Ammonia Concentration

Historical final effluent TSS loads are shown in Figure 4.6. As indicated in this figure, there have been several events in which the NPDES permit was violated due to an overwhelming effluent solids load. These events correspond to peak flow events and, in mid-2020, to the installation of aeration basin improvements, which required shutting down part of the secondary treatment system. Since the effluent filters should reduce the effluent TSS load to well below the NPDES permit criteria, these events indicate that the effluent filters became overwhelmed with solids during these periods, which suggests clarifier blanket failure occurred.

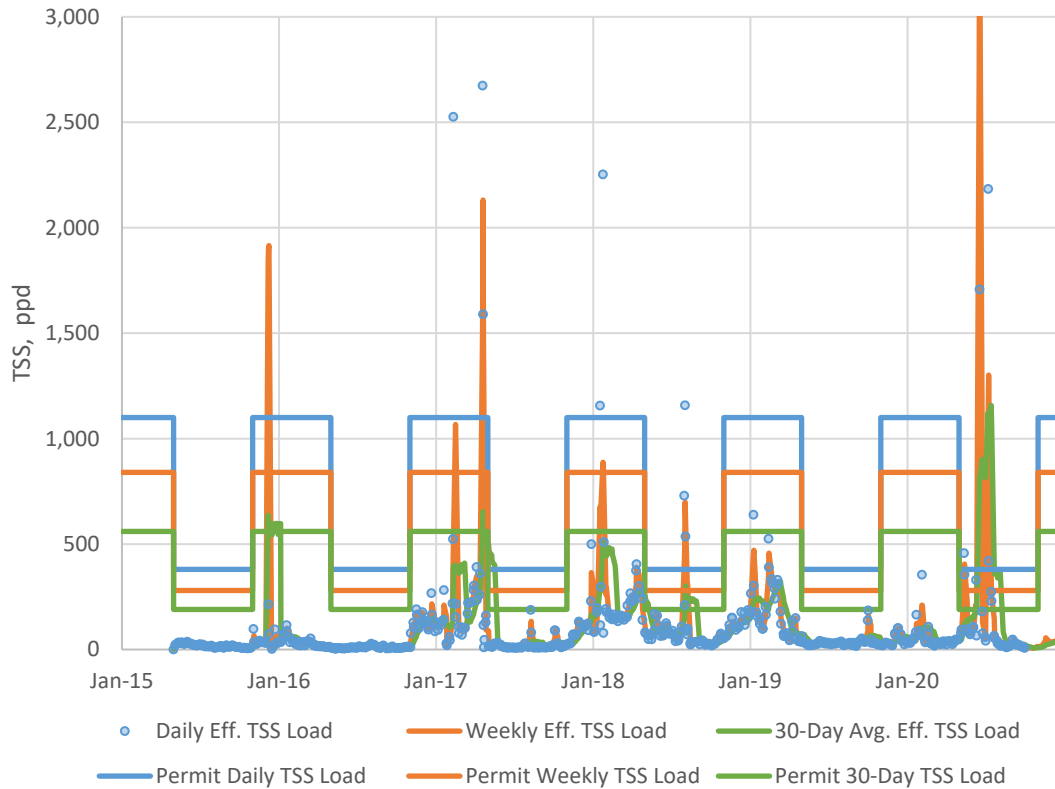

Figure 4.6 Historical Final Effluent TSS Loading

The maximum allowable maximum month MLSS concentration in the aeration basins is defined by the ability for MLSS to settle in the secondary clarifiers, quantified by measurement of the sludge volume index (SVI). Figure 4.7 shows the historical SVI in the secondary process alongside a 30-day running average value. During the period of record, the average 30-day SVI ranged from approximately 70 to 160 milliliters per gram (mL/g) and averaged approximately 100 mL/g. Subsequent analysis of secondary clarifier assumes a design SVI value of 150 mL/g, which is a typical maximum for well-settling sludge.

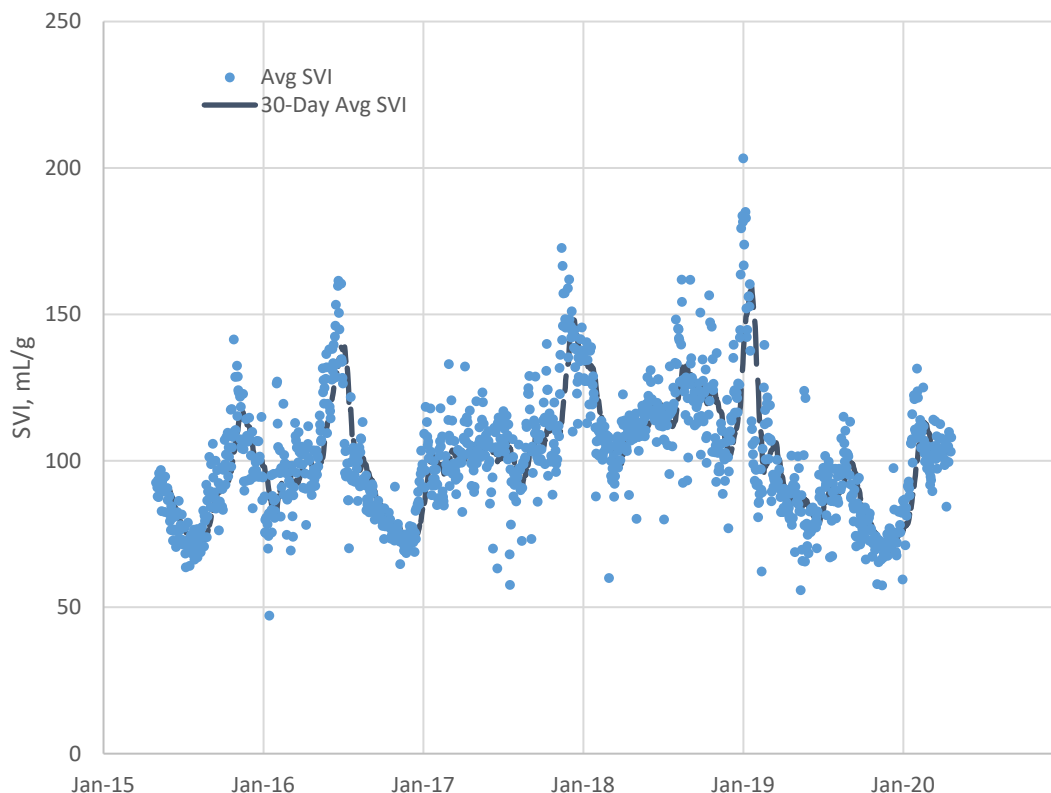

Figure 4.7 Historical Sludge Volume Index

4.3.2.3 BioWin Model Calibration

A steady state process model was used to determine the capacity of the secondary process and develop solids projections. The process model was developed in BioWin 6.2 and calibrated to the most recent data available which included the period when the new MLR pumps were operational – October 6, 2020 through December 31, 2020. During this period, the plant operated with all three aeration basins, all three secondary clarifiers, and both stabilization basins online. Table 4.2 shows the selected wastewater characteristics for the calibration period, and Table 4.3 summarizes the calibration results.

Table 4.2 BioWin Model Wastewater Characteristics

Influent COD Fraction	Selected Value	BioWin Default Value
F_{bs} (fraction of total COD which is readily biodegradable)	0.160	0.160
F_{ac} (fraction of readily biodegradable COD which is VFAs)	0.150	0.150
F_{xsp} (fraction of slowly biodegradable COD which is particulate)	0.693 ⁽¹⁾	0.750
F_{us} (fraction of total COD which is soluble unbiodegradable)	0.050	0.050
F_{up} (fraction of total COD which is non-colloidal particulate unbiodegradable)	0.130	0.130
F_{cel} (fraction of unbiodegradable particulate COD which is cellulose)	0.500	0.500
F_{na} (fraction of TKN which is ammonia)	0.660	0.660
F_{nox} (fraction of nitrogen which is particulate organic nitrogen)	0.500	0.500
F_{nus} (fraction of TKN which is soluble unbiodegradable)	0.020	0.020
F_{upN} (ratio of nitrogen to COD for unbiodegradable particulate COD)	0.035	0.035
F_{zbh} (fraction of total COD which is ordinary heterotrophic organisms)	0.020	0.020
COD/VSS ratio for slowly degradable COD	1.6327	1.6327
COD/VSS ratio of F_{zbh}	1.420	1.420
COD/VSS ratio of F_{up}	1.600	1.600

Notes:

(1) Decreased from default to match measured influent BOD/TSS ratio.

Abbreviations: COD-- chemical oxygen demand, TKN-- total kjeldahl nitrogen; VFA – volatile fatty acids; VSS – volatile suspended solids.

Table 4.3 BioWin Model Calibration Summary

Characteristic	Measured Value	Modeled Value	% Error
Influent			
Flow, mgd	2.19	2.19	0.0%
BOD load, ppd	7,530	7,540	0.1%
TSS load, ppd	6,080	6,080	0.1%
NH ₃ -N load, ppd	580	580	-0.1%
Secondary Treatment			
MLSS, mg/L	3,060	3,170	3.7%
MLVSS, mg/L	2,740	2,880	4.8%
RAS, mg/L	6,040	6,060	0.4%
RAS flow, % of Influent	141%	120%	-14%
aSRT, days	7.3	7.3	0.1%
Yield, lb TSS / lb BOD	0.81	0.83	2.3%
Secondary Effluent			
cBOD load, ppd	6.2	3.0	-51%
TSS load, ppd	110	120	8.2%
Final Effluent			
BOD load, ppd	68	35	-48%
TSS load, ppd	44	48	10%
NH ₃ -N load, ppd	53	2.7	-95%
Solids			
WAS load, ppd	5,880	6,060	3.1%
TWAS load, ppd			
Cake load, ppd	4,380	4,280	-2.3%

Notes:

Abbreviations: cBOD – Carbonaceous Biochemical Oxygen Demand; NH₃-N – ammonia (as Nitrogen); MLVSS – mixed liquor volatile suspended solids; WAS – waste activated sludge.

During this calibration period, the dewatering centrifuge solids capture was poor (approximately 72 percent). Operations staff reliably achieve 90 percent solids capture under normal operating conditions. Since these centrifuges are currently being refurbished, it is assumed for subsequent model runs that the solids capture on the dewatering centrifuges is 90 percent.

Key differences between the calibrated model and the measured values include that the calibrated model indicates somewhat higher BOD removal and significantly higher NH₃ removal. The latter difference, commonly observed in steady-state modeling, is likely due to the nature of steady-state models, which does not subject the activated sludge process to diurnal variations. Since the NPDES permit for the WWTP does not include effluent nitrogen limits, this difference between modeled and actual performance was disregarded.

Lastly, Chapter 3 – Wastewater Flow and Loads Projections indicates that the fraction of influent load from industrial sources is expected to increase in the future. To maintain the projected ratio of influent BOD to TSS expected under future loads, F_{bs} was increased to 0.1648 from the default of 0.1600, and F_{xsp} was decreased from 0.6930 to 0.6722 accordingly. These changes reflect an increase in the ratio of soluble COD to particulate COD entering the plant with higher industrial.

4.3.2.4 Design Criteria

The design criteria for the secondary treatment system are as follows:

- The aeration and stabilizations basins should provide a total SRT of six days under average dry weather and maximum month conditions, per the design criteria provided in the 2019 Aeration Basin Improvements project record drawings. The total SRT is reduced to five days under maximum week conditions, per discussion with operations staff.
- The hydraulic model results from the 2012 WWTP Improvements project indicates the three secondary clarifiers can pass a peak hour flow of 16 mgd (or 1,386 gpd/sf).
- The secondary clarifiers must be capable of settling sludge under peak day flow conditions at a maximum week solids inventory in the secondary treatment process, with sludge settling at a design SVI of 150 mL/g. The selection of this design SVI is described below. The maximum week inventory was determined by running a BioWin model starting at the steady state maximum month condition and then running a seven-day dynamic model using the maximum week flows and loads.
- Under average dry weather conditions, the secondary treatment system should be able to operate normally with either a single stabilization basin, a single aeration basin, or a single secondary clarifier out of service to allow for maintenance in the dry weather season. Under maximum month and maximum week conditions, it is assumed that all basins and clarifiers are in service.
- The overall RAS pumping rate must be sufficient for removing solids from the secondary clarifiers under all conditions with a single pump out of service to allow for pump maintenance as needed. This value is either the flow percentage required to avoid blanket failure in state point analysis under peak hour flow conditions, 50 percent of the peak hour flow, or 100 percent of the maximum month flow, whichever is largest.
- The blowers must provide sufficient air under maximum week and peak (modeled as 1.3 multiplied by the maximum month oxygen transfer rate) flow and load conditions with the largest unit out of service to allow for blower maintenance as needed. In this case, modeled peak conditions resulted in more conservative air demands, so only peak conditions are presented throughout the rest of this Chapter.

4.3.2.5 Unit Process Capacities

State point analysis (SPA) was used to evaluate the ability of secondary clarifiers to settle sludge under various conditions. The design SVI was used to generate the state point diagram, shown in Figure 4.8. The solids flux curve describes the capacity for a secondary clarifier to settle sludge. The overflow line is defined by the surface overflow rate at the design flow, and the underflow line is defined by the RAS flow rate and concentration. The point at which the underflow line and the overflow line intersect is the state point. If the state point is above solids flux curve, then settling failure will occur in the clarifier. Additionally, sludge blanket failure may occur if the maximum RAS rate generates an underflow line which intersects the solids flux curve to the right

of the state point. This indicates that the solids removed from the clarifier via RAS is insufficient to prevent the sludge blanket from rising.

Figure 4.8 shows the 2027 SPA using the max week MLSS predicted from the BioWin modeling using a design total SRT of five days at peak day flow with all secondary clarifiers in service. Since the state point falls under the solids flux curve, the state point analysis indicates that secondary system capacity is sufficient to handle the maximum week inventory through approximately the year 2027. This same analysis was done with the maximum month inventory coupled with the peak day flow and indicates the secondary system has sufficient capacity through approximately the year 2028. When receiving average dry weather loads, the system has sufficient capacity to take either an aeration basin or a secondary clarifier out of service for maintenance through approximately the year 2035 when coupled with the peak day dry weather flow. The current system has capacity through approximately the year 2033 if a stabilization basin needs to be taken out of service during the average dry weather loads coupled with the peak day dry weather flow. These capacities are represented in Figure 4.9, presented in terms of the influent BOD load corresponding to the design year in which the state point analysis indicates clarifier failure may occur.

Note that the plant has historically operated at significantly longer SRTs than are used as the basis for this capacity evaluation, as illustrated in Figure 4.3. This is largely due to the limited solids handling capacity of the plant forcing operations staff to minimize solids wasting to the extent possible. Following the completion of the 2019 Aeration Basin Improvements project, operations staff have significantly reduced the SRT in the secondary treatment system and indicate that they can operate the secondary treatment system at a six-day SRT year-round.

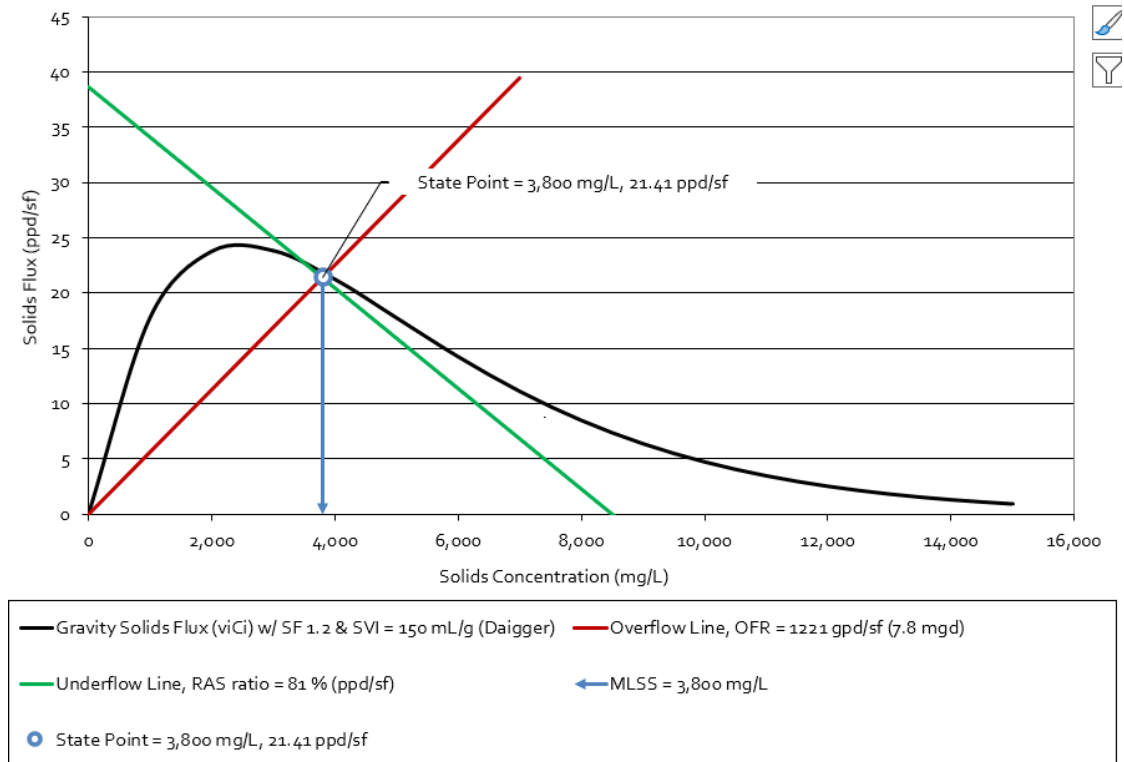

Figure 4.8 SPA for 2045 Max Week MLSS at Peak Day Flow

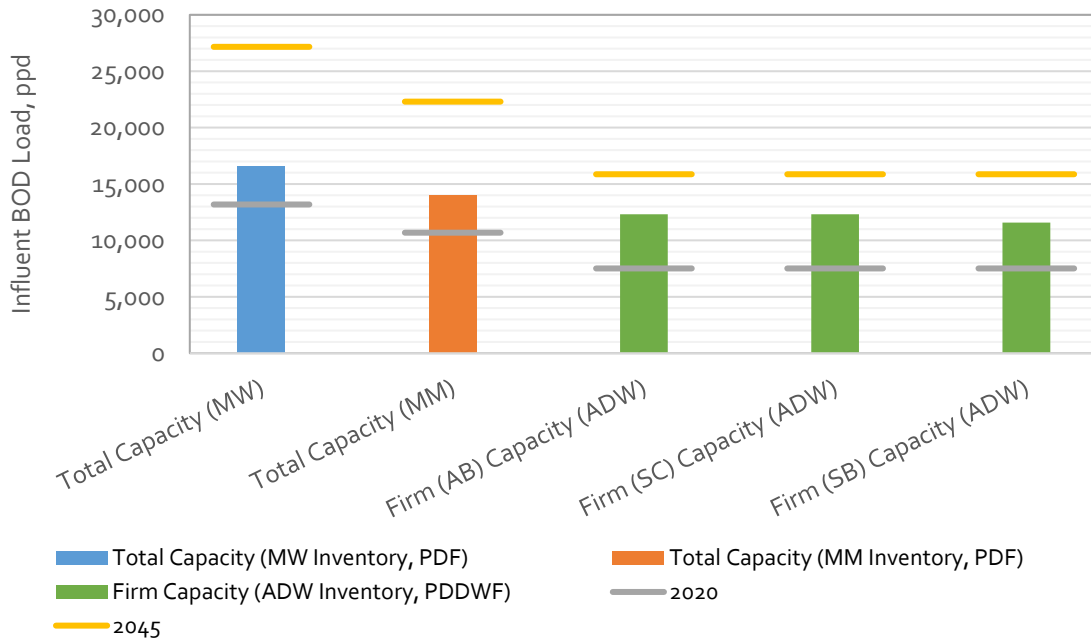

Figure 4.9 Secondary Treatment Capacity

As shown in Figure 4.10, the secondary clarifiers are expected to exceed the maximum hydraulic capacity of 16 mgd with all units in service by 2045. However, with one secondary clarifier out of service, the firm hydraulic capacity of the secondary clarification has sufficient capacity to treat the max month dry weather flows for the entirety of the planning period.

The secondary treatment process analysis indicates that the existing secondary treatment process does not provide sufficient capacity through the planning period. Additional aeration basin capacity is required by approximately the year 2027 to treat the projected maximum week load and additional clarification capacity is required by approximately the year 2040.

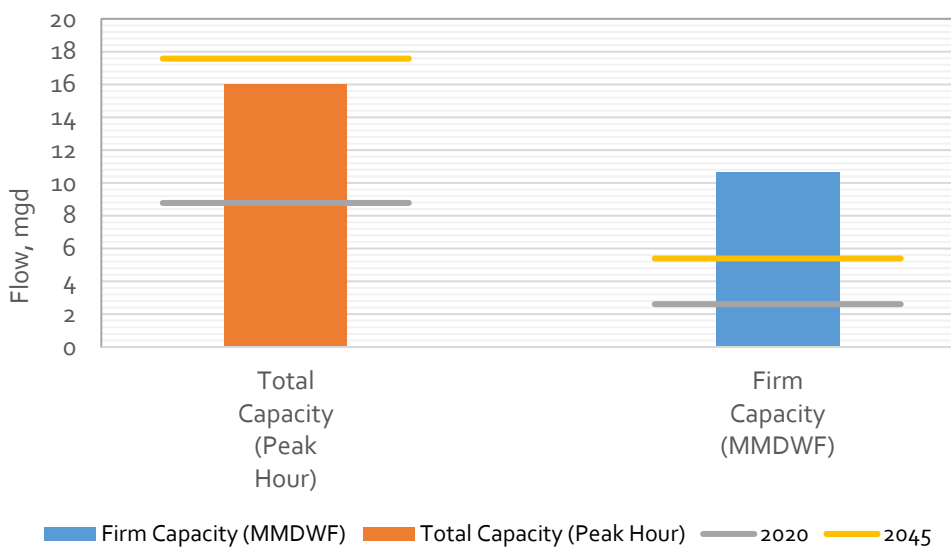

Figure 4.10 Secondary Clarifier Capacity (Surface Overflow Rate)

4.3.3 Tertiary Treatment and Disinfection

Following secondary treatment, secondary effluent is filtered, cooled, and disinfected. Tertiary filtration is used year-round, but only treats a portion of the total secondary effluent flow. Likewise, the cooling towers only treat a portion of the secondary effluent flow, but they are only used when required to meet excess thermal load (ETL) permit limits. All the treated wastewater is disinfected by the UV system prior to discharge. A schematic illustrating the tertiary treatment and disinfection processes is provided in Figure G.3 of Appendix G.

The secondary effluent pump station lifts secondary effluent to the level required to flow by gravity through the disc filters and subsequent disinfection. These pumps also lift flow to the secondary effluent cooling towers. Since the plant operates the filters year-round, irrespective of effluent quality, and since the firm capacity of the filters is greater than the cooling towers, it is assumed that all flow through the cooling towers is also sent through the filters. Thus, the secondary effluent pump station needs to only lift the amount of flow required for filtration.

4.3.3.1 Disc Filters

Two sets of Siemens 40-X Disc Filters were installed downstream of the secondary clarifiers as part of the 2012 WWTP Improvements project. Disc filters reduce the TSS of the plant's secondary effluent and aids with the efficacy of UV disinfection by increasing the UVT. While the strict TSS limits during the dry weather season drove the installation of these tertiary filters, operators run secondary effluent through these filters year-round, as they improve effluent quality and do not require significant additional energy or maintenance to run them continuously.

The design criteria for the disc filters are as follows:

- Each disc filter treats up to 3.75 mgd, per the manufacturer's data sheet.
- The net effective filtration area for each filter is 808 sf, per the manufacturer's data sheet.
- The maximum solids loading rate on the filters is 1 lb/day/sf, per the 2012 WWTP Improvements Project Documents. Thus, the overall maximum solids loading rate to each filter is 808 lb/day.
- The disc filters needs to be able to accommodate the PDDWF with all units in service and the MMDWF with a single unit out of service.

As seen in Figure 4.11, the existing disc filters will not have adequate capacity to handle MMDWF in 2045 with one unit out of service. The hydraulic capacity of the filters is expected to be exceeded by 2032.

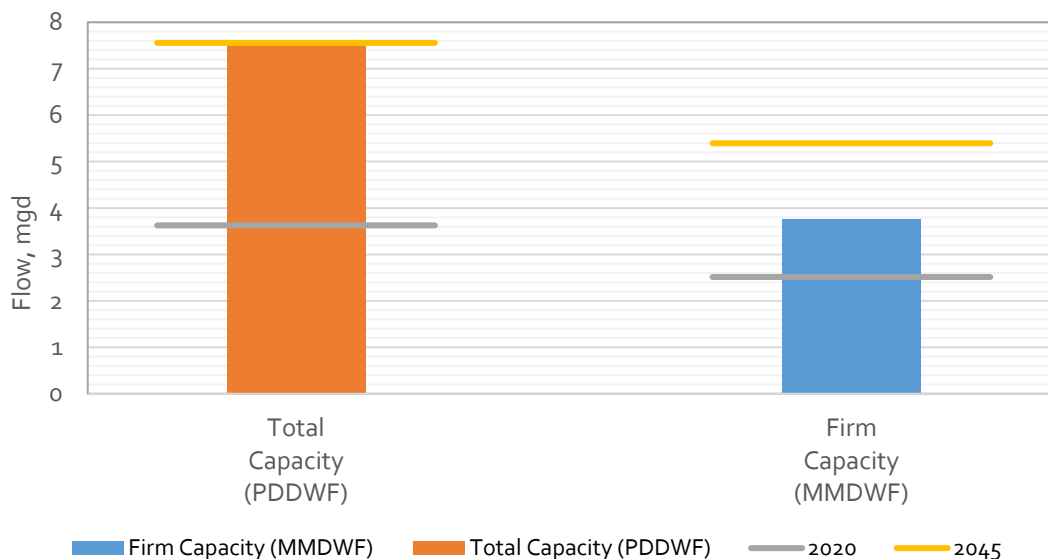

Figure 4.11 Disc Filter Hydraulic Capacity

The filter capacity is limited by the maximum solids loading rate. Therefore, effective secondary clarification upstream of the filters is critical to limit the solids loading rate to the filters to maintain filter capacity. The disc filters can only filter effectively when the influent TSS concentration is less than 35 mg/L based on the manufacturer’s data sheet, but as the flow to a single disc filter increases above 2.8 mgd, the influent TSS concentration must be reduced even further to prevent exceedance of the solids loading rate criterion. At the hydraulic loading rate limit of 3.75 mgd, a single filter can only operate effectively when the influent TSS is less than 26 mg/L. Thus, maintaining effective secondary clarification and maintaining a low secondary effluent TSS is essential to realizing the full capacity of the disc filters. Historical plant data was analyzed to determine the frequency with which the secondary effluent TSS exceeded 26 mg/L. Excluding 2020 when process upsets associated with the Aeration Basin Improvements Project construction resulted in high secondary effluent TSS events, the 92nd percentile secondary effluent TSS concentration was only 23 mg/L.

4.3.3.2 Secondary Effluent Cooling Towers

From June 1 to September 30, secondary effluent must be cooled in one of two cooling towers to comply with the ETL limits in the NPDES permit. Option A of the City’s NPDES permit limits the ETL to 39 million kilocalories per day. This option assumes that the temperature of the river is 20 degrees Celsius (°C) and does not consider actual river temperatures. The permit also indicates that the 39 million kilocalories per day limit be compared to a seven-day average effluent thermal load calculated based on the maximum daily temperature and the average daily flow. Cooling tower feed pumps must lift flow through the cooling towers from the pumped

secondary effluent flow stream. The design criteria for the secondary effluent cooling towers are as follows:

- The design wet bulb temperature for the cooling towers is 68°F, per the 2012 WWTP Improvements project documents.
- The design approach temperature for the cooling towers is 5°F, per the 2012 WWTP Improvements project documents. This indicates that at the design wet bulb temperature, the secondary effluent can be cooled to 73°F.
- The design flow rate through the cooling towers is two mgd each, per the 2012 WWTP Improvements project documents.
- The cooling towers should be capable of reducing the secondary effluent temperature such that the ETL to the Willamette River is less than 39 million kilocalories per day with both towers in service. It is assumed that both units are available for duty service from June 1 to September 30, and that any necessary maintenance is completed outside of this period.

The capacity of the cooling towers to remove the necessary ETL is, in practice, limited by the ambient conditions in which it operates. When the wet bulb temperature equals 68°F, the maximum weekly flow that can be discharged while staying under the ETL of 39 million kilocalories per day is 3.7 mgd. During the low flow periods of July and August, this flow is expected to be exceeded by the year 2040. The 2021 ASHRAE Handbook - Fundamentals documents the July wet bulb temperatures for the Aurora State Airport located approximately three miles south of the WWTP as less than 67.7°F 95 percent of the time in July and August. This means that about 37 hours during each of these summer months may be expected to exceed the design wet bulb temperature for the cooling towers potentially contributing to exceedances of the effluent ETL, depending on the plant daily flow rate.

During periods where the wet bulb temperature exceeds 68°F, the secondary effluent can only be reduced to a temperature 5°F higher than the wet bulb temperature. Hot, humid days reduce the efficacy of the cooling towers. The 2021 ASHRAE Handbook - Fundamentals documents that the July wet bulb temperature is expected to be less than 73.1°F, 99.6 percent of the time at the Aurora State Airport. This means that 3 hours of the month are expected to exceed this design wet bulb temperature. At a design wet bulb temperature of 73.1°F, the maximum seven-day average flow that can be discharged is approximately 1.8 mgd which is close to the current maximum weekly flows during the low flow periods of July and August. Given the impact of the actual wet bulb temperature on the maximum allowable weekly flows, careful attention should be paid to the flows and actual wet bulb temperatures during these months.

In addition to the ambient temperature considerations impacting evaporative cooling effectiveness described above, the existing cooling towers must also be assessed in light of their rated hydraulic capacity. On a flow basis, there were several days in the dry weather period from 2015-2020 in which the ETL prior to cooling exceeded 39 million kilocalories per day, and the effluent flow rate exceeded 2 mgd. It is assumed that, on these days, 100 percent of the secondary effluent flow must be cooled to meet the ETL limit, and operation of both cooling towers would be required to meet the permitted ETL. For 2045 conditions, it was assumed that the influent wastewater temperature would be the same as current conditions, but that the daily flow rates on days when the cooling towers are needed to meet the ETL limit would increase by the ratio of the 2045 base wastewater flow rate to the 2021 base wastewater flow rate established in Chapter– 3 - Wastewater Flows and Load Projections.

The cooling towers are designed for a maximum combined hydraulic flow rate of 4 mgd. As illustrated in Figure 4.12, while the total hydraulic capacity of the cooling towers is sufficient currently, it will not be sufficient in 2045. The hydraulic capacity of the cooling towers is predicted to be exceeded in 2036.

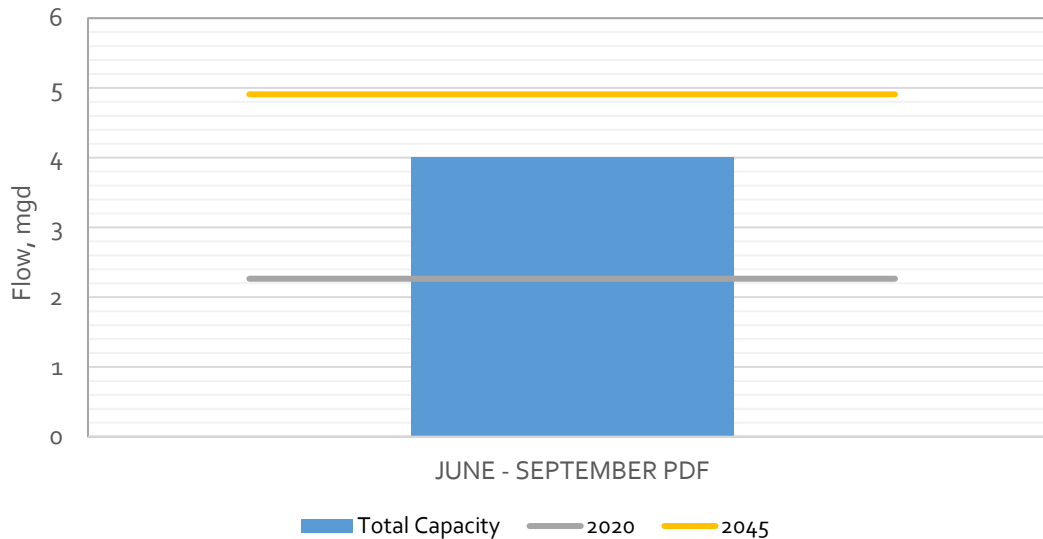

Figure 4.12 Cooling Tower Capacity

4.3.3.3 UV Disinfection

Filtered and/or cooled effluent is combined with the remaining secondary effluent and flows through one of two UV disinfection channels. The design criteria for the UV system is as follows:

- Each channel and UV system is rated for eight mgd. Critically, the UV systems are only rated for this flow when the UVT is 65 percent or higher on average, or 55 percent or higher under peak conditions, per the 2012 WWTP Improvements Project.
- Per the *Wastewater Planning Design Guide*, the plant must be capable of disinfecting the PDDWF with one unit out of service, and the PHF with all units in service.

As seen in Figure 4.13, the existing UV channels do not have adequate capacity to disinfect the 2045 PHF with all units in service. However, the firm capacity of the UV system is sufficient to treat the PDDWF through the year 2045 with one channel out of service.

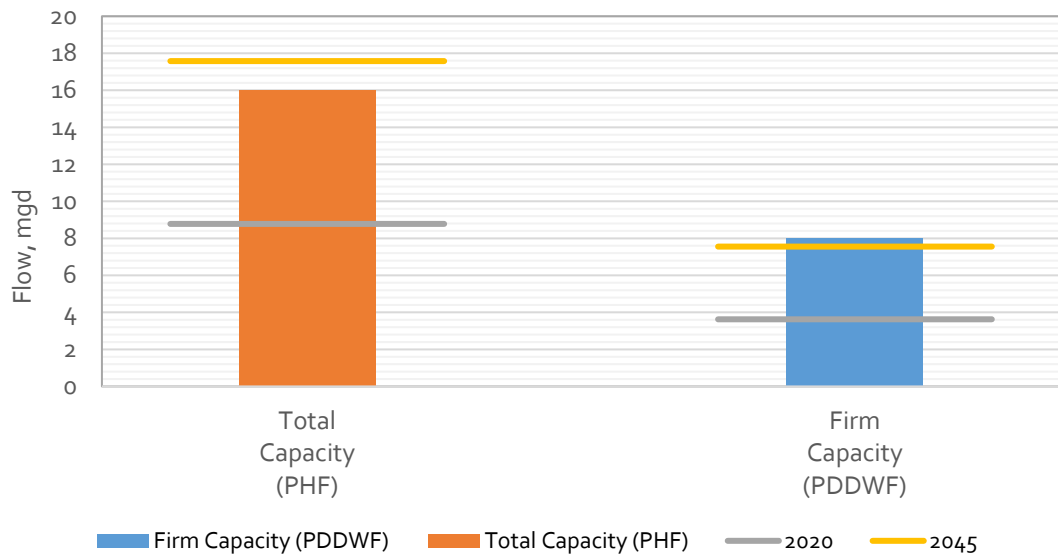

Figure 4.13 UV Disinfection Capacity

4.3.3.4 Outfall

Carollo Hydraulix® hydraulic modeling software was used to establish the hydraulic capacity of the outfall and water surface elevations for current and future flows. The model provides both energy and hydraulic grade lines according to each hydraulic element's head loss and velocity using Darcy-Weisbach equation for friction losses. The model was built using pipe and facility information taken from record drawings. The outfall capacity was defined in this case as the amount of flow that could pass through the outfall pipeline while still providing a six-inch drop over the UV channel effluent weir. This hydraulic break between the UV system and the outfall pipe ensures that the outfall has no hydraulic impact on the upstream processes.

The existing outfall was recently modified with five parallel diffuser pipes equipped with duckbill check valves to improve the mixing zone characteristics in the Willamette River. This analysis assumed that the Willamette River was at its 100-year flood elevation. Even at this maximum river level, it is expected that the outfall can discharge approximately 19 mgd before the UV channel effluent weirs are at risk of submergence. This is well above the hydraulic capacity of the rest of the plant, as shown in Figure 4.14, and thus no expansion will be needed during the planning period.

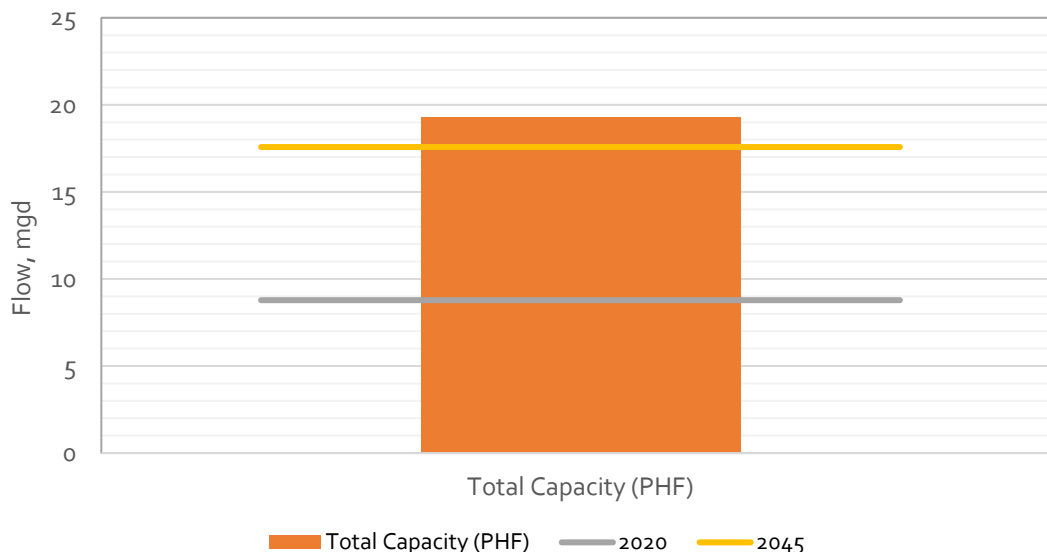

Figure 4.14 Outfall Hydraulic Capacity

4.3.4 Solids Handling

The solids handling process consists of WAS storage, WAS thickening, TWAS storage, centrifuge dewatering, and biosolids drying. A schematic illustrating the solids handling process at the plant is provided in Figure G.4 in Appendix G.

4.3.4.1 WAS Storage

WAS is diverted from the main RAS pump discharge header at a target rate using a flow control valve into a pair of 49,500 gallon WAS storage tanks to allow for intermittent operation of the GBTs. The typical storage time in these tanks is 10 - 23 hours. However, the GBT can operate continuously if needed, so the WAS storage capacity is not a capacity-limiting criterion, as WAS storage is only needed when the GBTs are not in use.

4.3.4.2 WAS Thickening

WAS is pumped from the WAS storage tanks and thickened in one of two 1.5-meter GBTs. As seen in Figure 4.15, from mid-2015 to mid-2017, the typical TWAS concentration ranged from approximately 3 to 6.5 percent TS and averaged approximately four percent TS. Operations staff prefer to maintain a TWAS concentration of four percent or less to maintain centrifuge performance, which does not perform as well at higher feed TS concentrations.

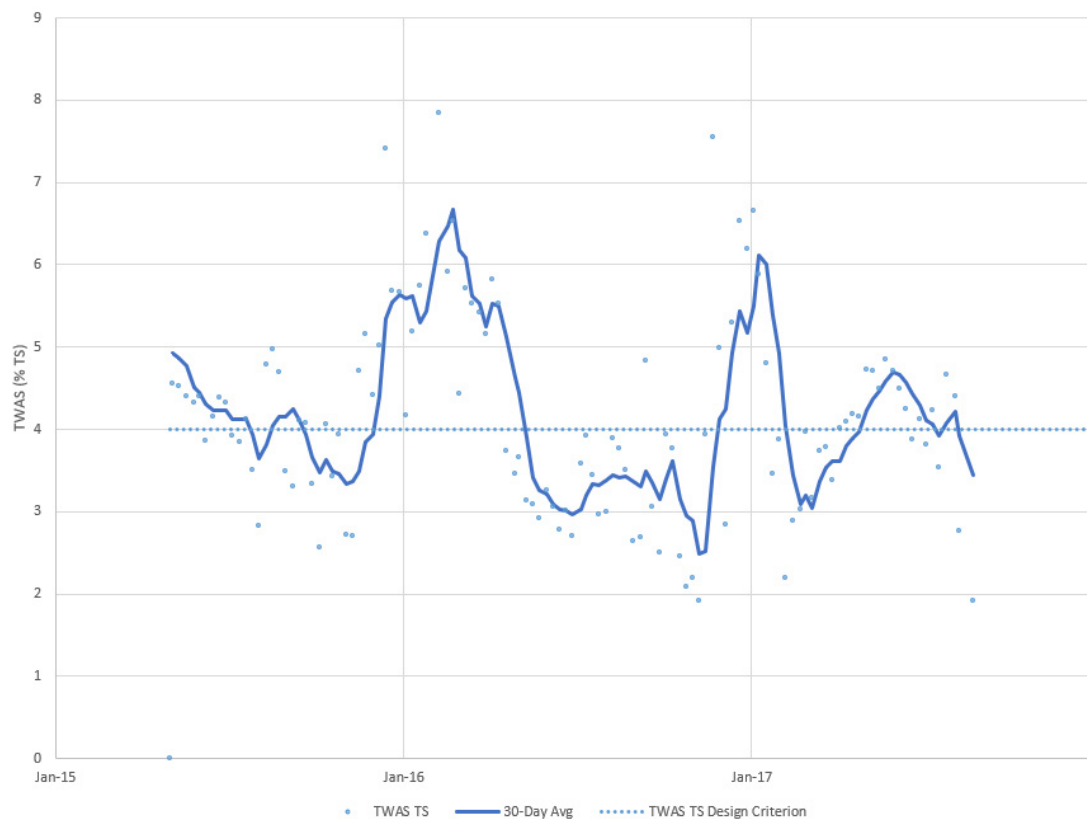

Figure 4.15 Historical Gravity Belt Thickener Performance

The design criteria for the gravity belt thickeners are as follows:

- Each GBT can thicken up to 300 gpm of feed sludge, or 200 gpm per meter of belt width, based on the record drawings from the 1993 upgrade.
- Each GBT is limited to a maximum solids loading rate of 900 lb/hr, or 600 lb/hr per meter of belt width, based on Carollo's experience with similar sized equipment of approximately the same age.
- The GBTs can be operated 24 hours per day, seven days per week, per discussion with operations staff.
- To allow for efficient dewatering operation and maintenance, the GBTs must be capable of thickening WAS to 4 percent under maximum week conditions with one unit out of service.

The capacity analysis results indicate that based on these operational parameters, there is sufficient capacity through approximately the year 2042 to thicken the projected maximum week WAS loads with one unit out of service as shown in Figure 4.16.

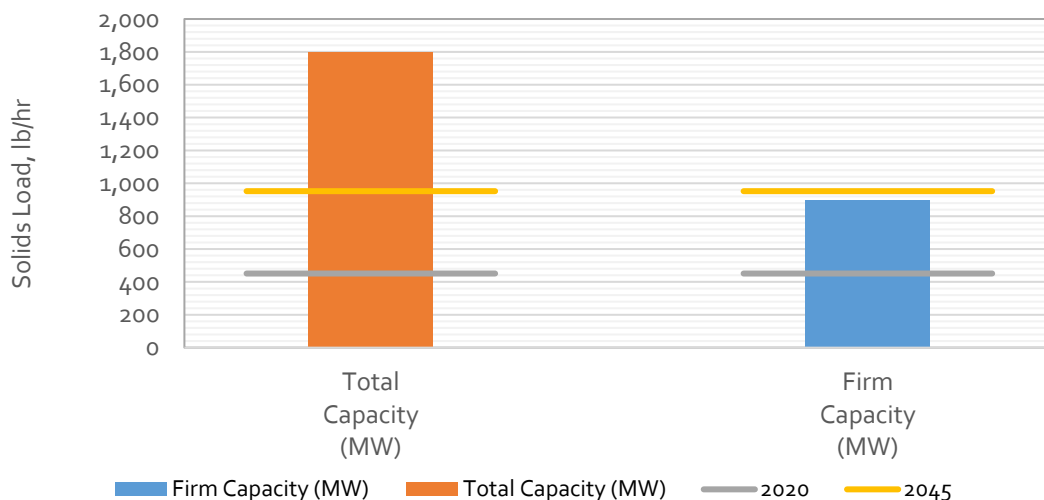

Figure 4.16 Gravity Belt Thickener Capacity

4.3.4.3 TWAS Storage

After thickening on the GBTs, TWAS is pumped to the TWAS storage tanks adjacent to the WAS storage tanks with progressive cavity pumps. The TWAS storage tanks provide the ability to store TWAS if the dewatering or drying processes are out of service. TWAS is stored in two 67,000 aerated holding tanks that allow for intermittent operation of the dewatering centrifuges. This volume provides sufficient capacity for approximately two days of storage of the projected maximum week TWAS loads with both tanks in service and about two days of storage of the projected average annual TWAS loads with one tank out of service. The City and contract operations staff indicated that this capacity is sufficient.

4.3.4.4 Dewatering Centrifuges

Two centrifuges dewater WAS and TWAS to approximately 20 percent TS. As described in section 4.3, the centrifuges typically achieve a solids capture percentage of approximately 90 percent, and have recently undergone major refurbishment to improve the low solids capture observed during the model calibration period.

The design criteria for the dewatering centrifuges are as follows:

- The maximum solids loading rate to a single centrifuge is 1,000 lb TS/hr, per the manufacturer's design criteria.
- The maximum hydraulic loading rate to a single centrifuge is 50 gpm, based on discussions with the City.
- The centrifuges are run 24 hours per day, 7 days per week.
- The centrifuges must be capable of dewatering the maximum week solids load with one unit out of service.

Based on these criteria, the current centrifuges have sufficient capacity to dewater the maximum week load with one unit out of service as is shown in Figure 4.17. Recently the City has not been able to operate their dewatering process at its rated capacity. If this issue can't be resolved, larger units will need to be installed to increase capacity.

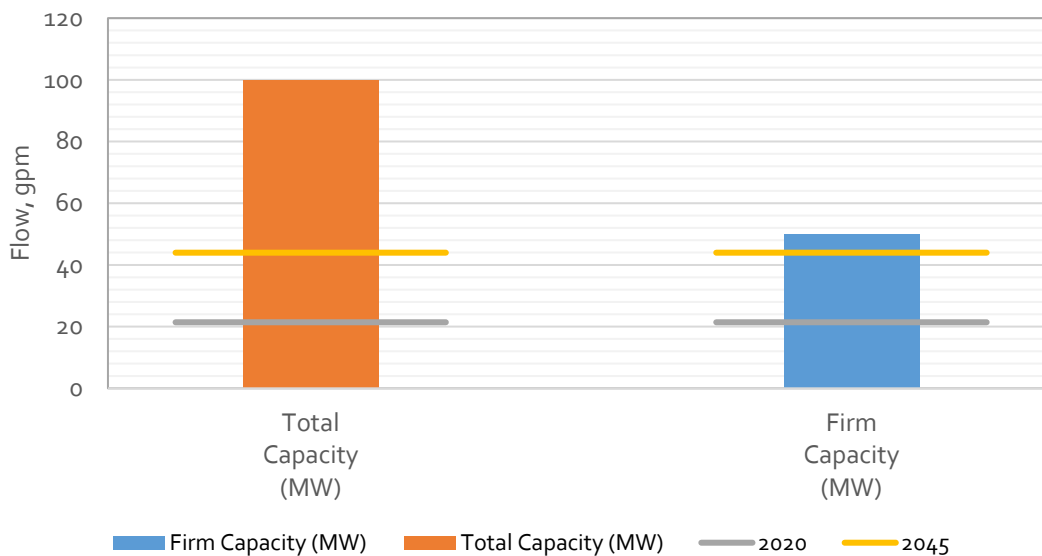

Figure 4.17 Dewatering Centrifuge Solids Loading Capacity

4.3.4.5 Biosolids Dryer and Solids Disposal

The biosolids dryer is currently operated five days per week, 24 hours per day. The operations staff have had difficulty with reliable operation of the dryer. At the beginning of the project the operations staff reported that the dryer began to experience problems after approximately four to six hours of running at its design temperature. Since that time, repairs were made to the dryer and now the dryer can operate continuously. This lack of redundancy and reliability have created issues for solids disposal. If the dewatered cake is not dried, the weight and volume is significantly higher and must be disposed of at the landfill.

The design criteria for the biosolids dryer are as follows:

- The evaporation rate in the dryer is limited to 3,600 lb/hr of water, per the 2012 WWTP Improvements Project Documents.
- Dewatered cake is fed to the dryer at 20 percent TS and dried to 92 percent TS, reflecting typical performance based on analysis of WWTP operations data.
- The dryer is operated 24 hours per day, seven days per week.
- Since there is no dryer redundancy, dryer maintenance necessitates that un-dried, dewatered solids are disposed of at the landfill.

As shown in Figure 4.18, the capacity of the biosolids dryer is adequate for the current and projected max week solids loads based on the above design criteria. However, as discussed above, dryer reliability concerns may lead the City to investigate replacement options within the planning period.

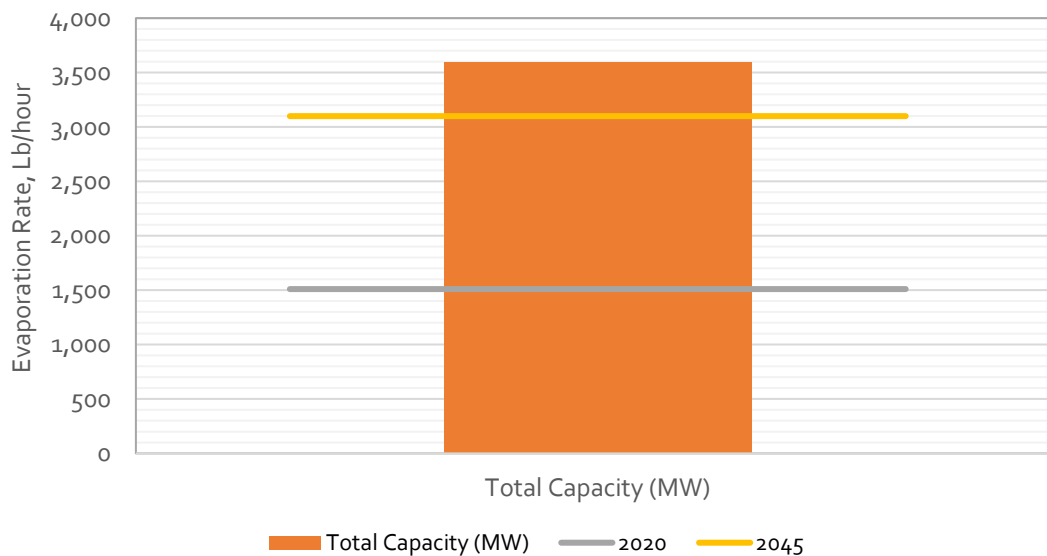

Figure 4.18 Biosolids Dryer Capacity

4.3.5 Plant Hydraulics

As mentioned in Section 4.3.1, the City engaged Jacobs in the summer of 2023 to evaluate plant hydraulics based on predicted 2045 influent PHF. That document (*Hydraulic Analysis TM*, August 31, 2023) is provided for reference in Appendix H. Jacobs found that under projected 2045 PHF conditions certain process and effluent piping may be hydraulically deficient.

At PHF 17.6 mgd and assuming a 0.8 mgd recycle scenario the headworks screens and grit removal systems are expected to be unsubmerged. However, upsized piping is expected to be necessary to convey flow from the headworks to the secondary process under these conditions

The 24-inch piping between MH-B (downstream of the UV disinfection process) and the 42-inch outfall downstream of MH-D2 is a hydraulic restriction for the PHF 17.6 mgd and 0.8 mgd recycle scenario. There are several options that could relieve the restriction. These are discussed further in Chapter 6.

4.4 Summary of Key Capacity Issues

The years in which key processes are expected to be exceeded within the planning period are summarized in Table 4.4. Prior to the year of capacity exceedance, the necessary planning, design, and construction activities will be required to be completed. Alternatives for addressing these capacity shortcomings are included in Chapter 6 - Alternatives Development and Evaluation. In addition, concerns with performance of the solids dryer unit led City staff to request evaluation of alternatives for replacement of that equipment. As such, additional discussion of the solids unit processes is presented in Chapter 6.

Table 4.4 Unit Process Capacity Year Summary

Unit Process	Design Parameter	Redundancy Criteria	Year of Capacity Exceedance
Influent Screening	PHF	Bypass channel with manual bar rack in service and one mechanical screen out of service	>2045
Grit Chamber	PHF	All units in service	2045
Secondary Treatment	MW MLSS Inventory at PDF	All units in service	2027
Secondary Effluent Cooling Towers	June 1 - Sept 30 PDF	All units in service	2036
Disk Filters	MWDWF	One unit in backwash	2032
UV Disinfection Channels	PHF	All units in service	2040
Outfall	PHF	-	>2045
Gravity Belt Thickening	MW Load	One unit out of service	2042
Dewatering Centrifuges	MW Load	One unit out of service	>2045
Biosolids Dryer	MW Load	All units in service	>2045

Chapter 5

REGULATORY CONSIDERATIONS AND
STRATEGY

5.1 Willamette River Flow

Flow data for the Willamette River is available from the U.S. Geological Survey (USGS) Water Data Reports at Newberg (USGS Station 14197900). Flow data are available from October 19, 2001 through July 30, 2020. Table 5.1 summarizes the monthly mean, maximum, and minimum river flows for the Newberg station between the dates available.

Table 5.1 Willamette River Flow Data from the USGS Station in Newberg

Month	Average Flow (cfs)	Maximum Flow (cfs)	Minimum Flow (cfs)
January	51,726	164,000	11,500
February	36,496	120,000	9,440
March	34,505	107,000	6,460
April	32,107	148,000	11,100
May	21,571	54,500	8,090
June	15,604	89,900	5,830
July	8,020	16,700	4,860
August	7,161	10,500	4,700
September	8,594	36,300	5,170
October	13,345	60,600	5,970
November	26,398	104,000	6,910
December	44,973	137,000	5,920

Notes:

Abbreviations: cfs - cubic feet per second.

River flow varies seasonally; Figure 5.1 shows the discharge curve from the USGS Station 14197900.

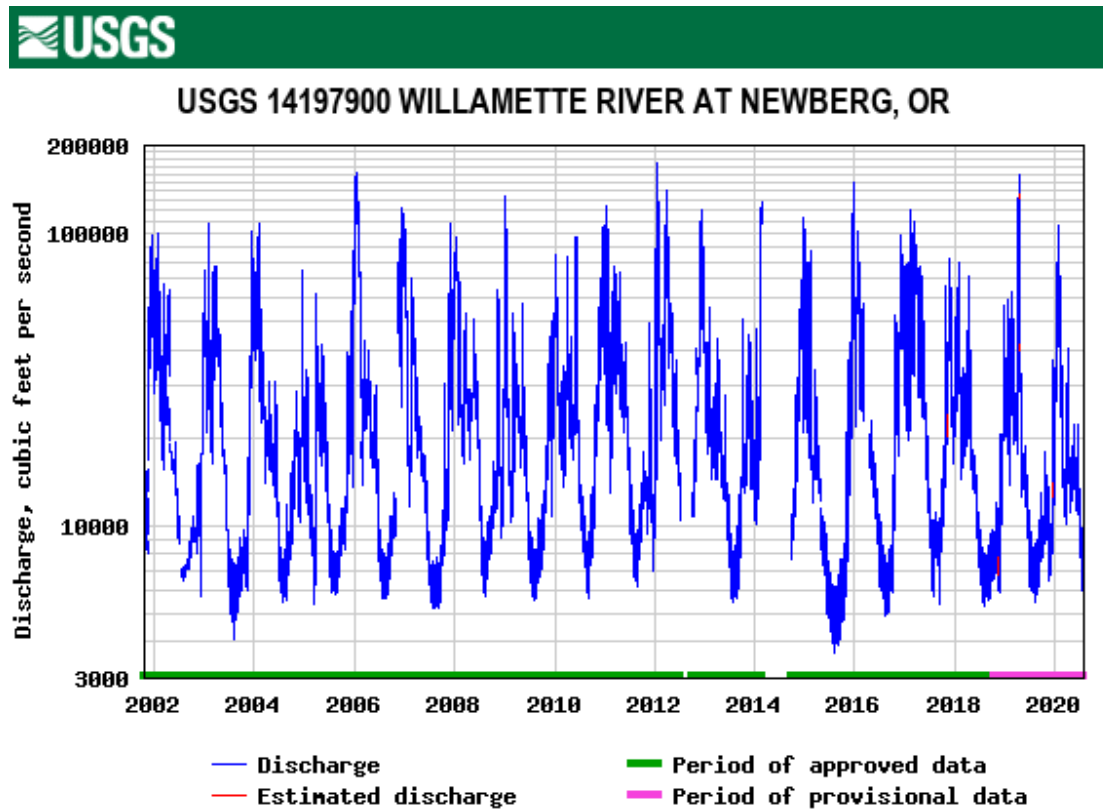

Figure 5.1 Historical Flow of the Willamette River at Newberg

A mixing zone study was published in February 2019 by Jacobs which evaluated the change in the mixing zone characteristics following the outfall replacement in 2018.

The study detailed the statistical flows for the Willamette River found in Table 5.2.

Table 5.2 Willamette River Statistical Flows

Item	Flow (cfs)
Dry Season 1Q10	5,646
Dry Season 7Q10	5,752
30Q5	6,315
Harmonic mean flow	13,966
Wet Season 7Q10	7,136
Wet season 50th percentile	25,970

The mixing zone study also listed the dilution factors associated with the statistical flows in Table 5.2. These dilution factors are based off 2018 WWTP flows and are found in Table 5.3. The NPDES permit defines the regulatory mixing zone (RMZ), also known as the chronic mixing zone and Zone of Initial Dilution (ZID), also known as the acute mixing zone, as:

“That portion of the Willamette River within 150 feet downstream of the outfall diffuser. The ZID is that portion of the allowable mixing zone that is within 15 feet downstream of each outfall diffuser port.”

Table 5.3 Dilution Factors from Mixing Zone Study

Item	Centerline Dilution at 15-foot ZID	Existing Flux-average Dilution at 150-foot RMZ	2025 Flux-average Dilution at 150-foot RMZ
Dry Season 1Q10	24	N/A	N/A
Dry Season 7Q10	N/A	192	107
30Q5	N/A	191	116
Harmonic mean flow	N/A	247	193
Wet season 50th percentile	N/A	198	88

5.2 Regulatory Framework

It is the responsibility of the Oregon DEQ to establish and enforce water quality standards that ensure the Willamette River’s beneficial uses are preserved. The DEQ’s general policy is one of antidegradation of surface water quality. Discharges from wastewater treatment plants are regulated through the NPDES. All discharges of treated wastewater to a receiving stream must comply with the conditions of an NPDES permit. The Environmental Protection Agency (EPA) oversees state regulatory agencies and can intervene if the state agencies do not successfully protect water quality.

The Wilsonville WWTP discharges to the Willamette River at River Mile 38.5 just upstream of the Interstate 5 bridge. A new multi-port diffuser was installed by the City in 2018 which improved the mixing available for the plant discharge.

5.3 Beneficial Uses

To assist in the development of water quality standards, a list of beneficial uses is established for each water body in the state. OAR 340-041-0340 lists the beneficial uses for the Willamette River in the vicinity of the City's treatment plants (Table 5.4).

The Willamette River at Wilsonville is designated for rearing and migration of all species of Salmon and Trout.

Table 5.4 Designated Beneficial Uses for the Willamette River from the Willamette Falls to Newberg

Beneficial Uses
Public Domestic Water Supply ⁽¹⁾
Private Domestic Water Supply ⁽¹⁾
Industrial Water Supply
Irrigation
Livestock Watering
Fish and Aquatic Life
Wildlife and Hunting
Fishing
Boating
Water Contact Recreation
Aesthetic Quality
Hydro Power
Commercial Navigation and Transportation

Notes:

- (1) With adequate pretreatment (filtration & disinfection) and natural quality to meet drinking water standards.
Source: OAR 340-041-0340.

5.4 Oregon Administrative Rules for Wastewater Treatment

The state surface water quality and waste treatment standards for the Willamette Basin are detailed in the following sections of the OARs:

- OAR 340-041-0004 lists policies and guidelines applicable to all basins. DEQ's policy of antidegradation of surface waters is set forth in this section.
- OAR 340-041-0007 through 340-041-0036 describes the standards that are applicable to all basins.
- OAR 340-041-0340 through 340-041-0345 contain requirements specific to the Willamette Basin including beneficial uses, approved TMDL in the basin, and water quality standards and policies.

The surface water quality and waste treatment standards in the OARs are viewed as minimum requirements. Additional, more stringent limits developed through the TMDL process would supersede the basin standards.

5.5 Total Maximum Daily Loads

The Clean Water Act requires DEQ to establish TMDLs and corresponding waste load allocations for all water bodies on the 303 (d) list. DEQ prepared a TMDL for mercury in 2006 which is being revised at this time. DEQ issued the revised draft TMDL in June 2019, and this draft was rejected by EPA. On December 30, 2019, EPA established the Willamette Basin Mercury TMDL. Minor changes were made to the TMDL after reviewing comments received during the public comment period, and EPA reissued the TMDL on February 4, 2021. It is anticipated that a waste minimization strategy will be used along with a variance since the mercury targets may not be attainable in the near term. Publicly owned treatment plants contribute 0.01 kilograms per year (kg/year) of the total of 2.23 kg/year.

DEQ also issued the temperature TMDL in 2006 which was initially approved by EPA. However, EPA's approval was challenged in Federal Court which ruled that the TMDL should not have been approved because it included a natural conditions provision that changed the temperature standard without due process. DEQ will need to update the Willamette Basin temperature TMDL. DEQ will present the Willamette Subbasins TMDL to the Environmental Quality Commission for proposed rule adoption in November 2023 to give EPA a minimum of 60 days for their approval or disapproval by Jan. 15, 2024. DEQ allocated the thermal loads to the City's plants as shown in Table 5.5.

Table 5.5 Temperature TMDL Allocations

River Flow Greater than, (cfs)	Allowed Temperature Increase, (degrees Celsius)	Thermal Load, (million Kcal/day)
0	0.0029	39
6,041	0.0027	40
6,367	0.0026	41
6,739	0.0025	41
7,415	0.0024	44
8,556	0.0022	46
13,001	0.0017	54

5.6 Cold Water Refuge

DEQ published the "Lower Willamette River Cold-Water Refuge Narrative Criterion Interpretation Study" in March 2020, which was submitted to the National Marine Fisheries Service. This study identifies six cold-water refuge (CWR) areas in the reach between the Willamette River Falls and Newberg. Just upstream of Wilsonville, the Coffee Lake Creek and Corral Creek confluences are listed CWRs. The closest downstream CWR is the Ryan Creek confluence at River Mile 44.2. The Wilsonville discharge will not influence these CWRs.

Implementation of the cold-water refuge is outlined in the draft report and the three proposed steps are listed below:

1. DEQ will implement existing temperature TMDLs to address temperature reductions in the main stem and cold-water tributaries to maintain and enhance the CWRs identified in this report. For example, implementing the Clackamas Basin TMDL will protect the quality of cold-water refuge provided by the Clackamas River confluence.

2. Designated management agencies (DMA) along the mainstem Willamette River are required to address CWR according to the 5-year Willamette Basin TMDL Implementation Plans. The Implementation Plans require DMAs to evaluate impacts to existing CWR, now identified in this study, identify additional CWR if applicable, and provide options for protecting or enhancing such areas.
3. NPDES permits for discharges are required to evaluate and prohibit thermal impacts to CWR under the authority of OAR 340-041-0053(2)(d). When permits are issued for discharges within the migration corridor, potential for impacts to the CWR identified in this report or by DMAs must be evaluated and thermal plume limitations applied as necessary.

In the recent permit fact sheet, DEQ summarized their analysis of the Wilsonville discharge and concluded that the discharge meets the thermal plume limits in OAR 340-041-0053(2)(d).

5.7 Clean Water Act 303 (d) Listing

The federal Clean Water Act requires that the responsible regulatory agency establish a list of water bodies that do not meet applicable water quality standards. In Oregon, this responsibility falls to the DEQ. This list, known as the 303 (d) list, classifies Category 5 impairments and is updated every two years. In September 2019, DEQ released the draft Oregon 2018-20 Integrated Report and is soliciting comments. The causes of impaired uses for the Assessment Unit from Champoeg Creek to the confluence with the Clackamas River are listed below:

- Aquatic Weeds
- Biocriteria
- Temperature-Year-Round
- Aldrin - Human Health
- Polychlorinated biphenyls - Human Health
- Dichlorodiphenyldichloroethylene 4,4' - Human Health
- Dichlorodiphenyltrichloroethane (DDT) 4,4' - Human Health
- Dieldrin - Human Health

In addition to the listing for this reach, listings of parameters for the downstream assessment units are shown below:

- Cyanide - Aquatic Life
- Ethylbenzene - Human Health
- Chlordane
- Chlorophyll-a
- Harmful Algal Blooms
- Iron (total) - Aquatic Life
- Dissolved Oxygen - Year-Round
- Hexachlorobenzene - Human Health
- Polycyclic Aromatic Hydrocarbons - Human Health

For the listed parameters, aquatic weeds and the biocriteria could all be related to the nutrient loading in the river. Aquatic growth is typically stimulated by nutrients that are available in the water. DEQ has not evaluated the conditions in the river to determine if the river is either nitrogen or phosphorous limited. However, upstream tributaries have been found to be phosphorous limited. A TMDL process will be necessary to establish future treatment requirements. Long-term planning should include provision of footprint at the plant for nutrient removal.

DEQ is required to implement the recent methylmercury standard promulgated by EPA. It is likely that DEQ will implement compliance through source control measures rather than permit limits.

Permit limits are not anticipated for the pesticides and legacy pollutants such as DDT and its derivatives.

5.8 Permit Limits

The existing permit limits for the Wilsonville WWTP are shown in Table 5.6. This permit became effective on September 1, 2020 and expires July 30, 2025.

Table 5.6 Effluent Permit Limits

Parameter	Average Effluent Concentration		Monthly Average (lb/day)	Weekly Average (lb/day)	Daily Maximum (lbs)
	Monthly	Weekly			
May 1 - October 31					
CBOD ₅	10 mg/L	15 mg/L	190	280	380
TSS	10 mg/L	15 mg/L	190	280	380
November 1 - April 30					
BOD ₅	30 mg/L	45 mg/L	560	840	1100
TSS	30 mg/L	45 mg/L	560	840	1100
Other Parameters Limitations					
E. coli Bacteria	<ul style="list-style-type: none"> Shall not exceed 126 organisms per 100 ml monthly geometric mean. No single sample shall exceed 406 organisms per 100 ml. 				
pH	<ul style="list-style-type: none"> Instantaneous limit between a daily minimum of 6.0 and a daily maximum of 9.0. 				
BOD ₅ Removal Efficiency	<ul style="list-style-type: none"> Shall not be less than 85 percent monthly average. 				
TSS Removal Efficiency	<ul style="list-style-type: none"> Shall not be less than 85 percent monthly average. 				
ETL June 1 through September 30	<ul style="list-style-type: none"> Option A: 39 million kcal/day 7-day rolling average. Option B: Calculate the daily ETL limit. 				

For Option B shown in Table 5.6 for the ETL limit, the daily ETL is calculated using the following formula:

- ETL = $((0.00006878 \times Q_R) + .8745) - 0.1 \times 2.94 \times 2.447 \times (24.3 - 20)$.
- Q_R = Rolling 7-day average ambient river flow at USGS Gauge No. 14197900 (Newberg).

The excess thermal load is computed based on the following formula:

- ETL = $3.785 \times Q_e \times \Delta T$.
- ETL = Excess Thermal Load.
- Q_e = Daily average flow (million gallons per day [mgd]).
- ΔT = Daily maximum effluent temperature (°C) minus ambient criterion (20°C).

5.9 Outfall

The Wilsonville WWTP Outfall 001 is located at River Mile (RM) 38.6. The peak wet weather hydraulic capacity of the WWTP is 16 mgd. In 2018, the single-port WWTP outfall was replaced with a new multi-port diffuser outfall that extends farther offshore to provide better dilution that enhances the ability for the discharge to meet water quality criteria. The outfall replacement eliminated the need for ammonia limits for toxicity control on future NPDES permits.

A mixing zone study evaluating the RMZ of the new diffuser outfall was published by Jacobs in 2019. Improved mixing is provided by the new diffusers and the dilution values shown in Table 5.3 are based on the new diffuser.

5.10 Toxicity

DEQ completed the Reasonable Potential Analysis (RPA) for metals and the priority pollutants based on the mixing zone analysis submitted by the City. This analysis is based on the mixing provided by the new outfall as shown in Table 5.3. This analysis included pH, temperature, ammonia, and toxics. The following conclusions were reached by DEQ:

- The RPA confirmed that the basin standards for pH will be met at the edge of the mixing zones.
- The Wilsonville WWTP discharge will not have a reasonable potential to exceed the temperature criteria.
- The discharge has no reasonable potential to exceed the ammonia water quality criteria.
- There is no reasonable potential that the discharge will cause aquatic toxicity at the edge of the mixing zones related to metals or priority pollutants.
- Except for mercury, there is no reasonable potential that human health criteria will be exceeded.

The City received approval from DEQ for the NPDES permit-required mercury minimization plan on May 10, 2022.

5.11 Temperature

The Willamette River temperature standard in the in the Lower Willamette River is 20° C during the dry season. DEQ established TMDLs for temperature and the City installed cooling towers to help meet the thermal load limits. Figure 5.2 shows the effluent temperature for the last five years of record and Figure 5.3 shows the thermal load discharged compared to the limit. In 2018 the WWTP approached the thermal limit.

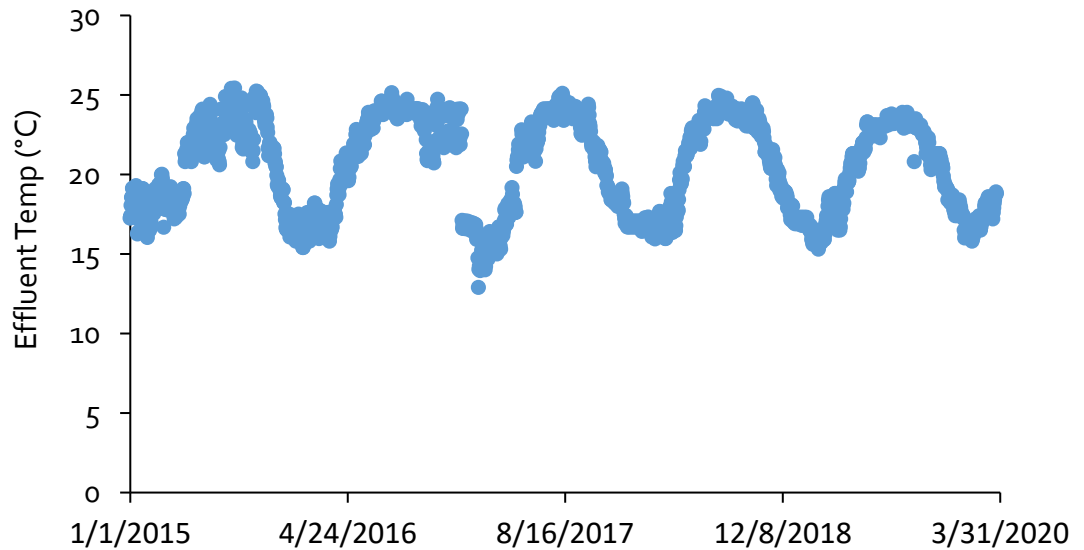

Figure 5.2 Effluent temperatures from 2015 through 2019

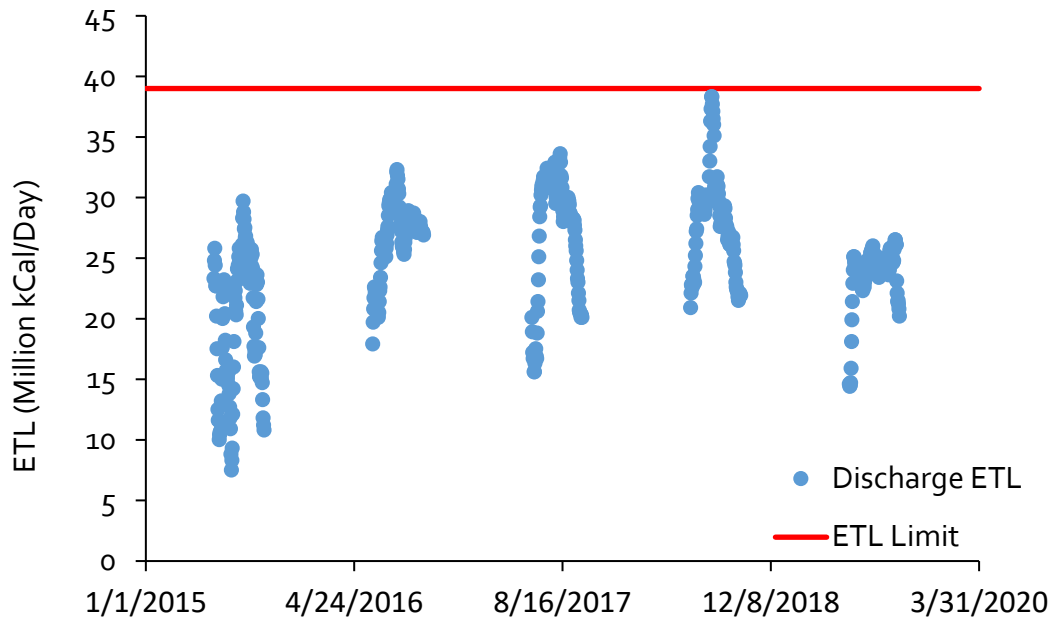

Figure 5.3 DMR-Reported ETL Discharged Compared to the NPDES Permit of 39 million kCal/day

The permit includes a provision for calculating the ETL limit based on river flow. An analysis for 2018 shows that Option B in the permit is not favorable during the peak temperature periods. Figure 5.4 shows the actual load versus both Option A and Option B. The Option B limit is lower than Option A during the critical period.

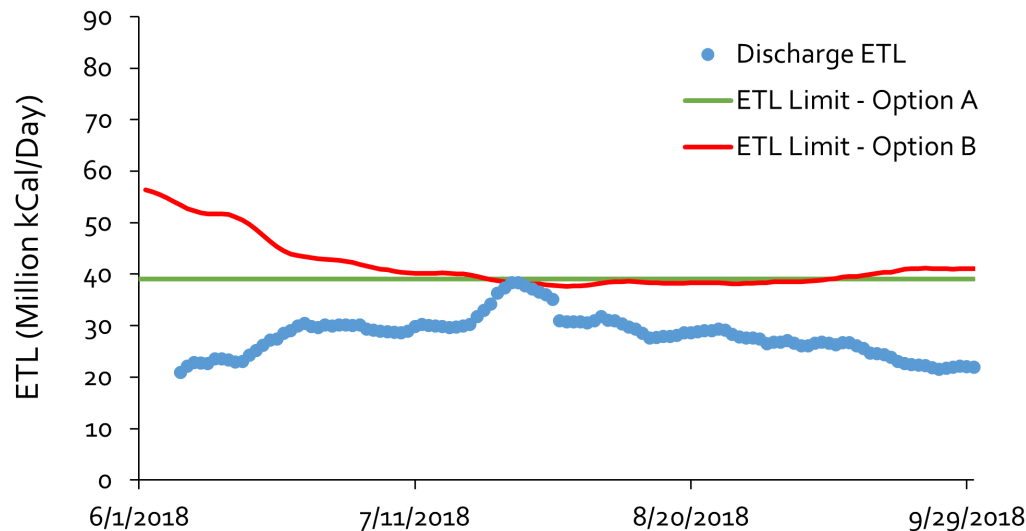

Figure 5.4 2018 Thermal Load versus Option A and Option B limits

The discharge ETL is based on the effluent flow and temperature compared to the river standard of 20° C. As effluent flows increase, the ETL will increase since the difference between the effluent temperature and river standard will not likely change. The cooling towers were designed with a minimum water discharge temperature of 22.8°C based on a wet bulb temperature of 20°C. Based on the current flow projections, this amount of cooling should allow the City to comply with the temperature TMDL through approximately the year 2040. The 2021 ASHRAE Handbook - Fundamentals documents the July wet bulb temperatures for the Aurora State Airport located approximately 3 miles south of the WWTP as less than 67.7°F, 95-percent of the time in July and August. This means that 37 hours of the month are expected to exceed the design wet bulb temperature for the cooling towers and thus, potentially exceed the ETL, depending on the plant daily flow rate.

During periods where the wet bulb temperature exceeds 68°F, the secondary effluent can only be reduced to a temperature 5°F higher than the wet bulb temperature. Hot, humid days reduce the efficacy of the cooling towers. The 2021 ASHRAE Handbook – Fundamentals documents that the July wet bulb temperature is expected to be less than 73.1°F, 99.6-percent of the time at the Aurora State Airport. This means that 3 hours of the month are expected to exceed this design wet bulb temperature. At a design wet bulb temperature of 73.1F, the maximum seven-day average flow that can be discharged is approximately 1.8 mgd which is close to the current maximum weekly flows during the low flow periods of July and August.

Additional strategies will be necessary to comply with the ETL limit once the wet bulb temperature begins to limit the amount of water that can be discharged and still meet ETL. Strategies to meet the ETL could include reducing the volume of water discharged through reuse, purchasing shading credits, or using a chiller to cool the water below temperatures which

the cooling towers can provide due to evaporative cooling limitations at elevated wet bulb temperatures.

5.12 Future treatment requirements

The City of Wilsonville NPDES permit became effective on September 1, 2020. Future treatment requirements will likely be implemented when the DEQ prepares TMDLs for the lower Willamette River.

5.13 Mass Load

Schedule D of the permit includes the following requirement related to mass load:

10. Within 24 months of permit expiration (beginning of the 4th year of the permit), the permittee shall submit either an engineering evaluation which demonstrates the design average wet weather flow, or a request to retain the existing mass load limits at the next permit renewal. The design average wet weather flow is defined as the average flow between November 1 and April 30 when the sewage treatment facility is projected to be at design capacity for that portion of the year. Upon acceptance by DEQ of the design average wet weather flow determination, the permittee may request a permit modification to include higher winter mass loads based on the design average wet weather flow.

Mass load will control the maximum concentration of CBOD and suspended solids that can be discharged as growth increases plant flows. Based on the 2045 flows that are projected for the City, the concentration that can be discharged will be lower than the permitted concentration limits as shown in Table 5.7.

Table 5.7 Permitted Mass Load Limits Impact on Allowable Concentrations

Flow	Projected 2045 Plant Flow (mgd)	Permit Limit (lbs/day)	Concentration, mg/L		
			Mass Limited	NPDES Permit Limits	DBO Limits
MMDWF	5.4	190	4.2	10	5
MMWWF	7.8	560	8.6	30	16
MWDWF	6.3	280	5.3	15	8
MWWWF	9.4	840	10.7	45	25
PDDWF	7.6	380	6.0	NA	NA
PDWWF	11.4	1100	11.6	NA	NA

The wastewater treatment plant is operated by the Design Build Operate (DBO) firm (Jacobs) under a contract that stipulates that the concentration of effluent for both CBOD and suspended solids must be half of the concentration limits in the NPDES permit. As is shown in Table 5.7, impact of the projected flow and loads suggests that by the year 2045 the mass load limited concentrations will be lower than what is currently required in the DBO contract. The City anticipates the approach to managing effluent TSS load could become more challenging as service area growth occurs resulting in mass load exceedances for TSS in the future. As a result, the City submitted a request to DEQ on June 15, 2023 to consider increasing the effluent mass load limit in the WWTP NPDES permit.

5.14 Dissolved Oxygen

Future treatment requirements will depend on water quality assessments of the Lower Willamette River to address the water quality parameters that are not being met. The dissolved oxygen in the lower reaches does not always meet water quality standards. Under existing permitted conditions for wastewater treatment plants that discharge to the river, the dissolved oxygen would drop well below the water quality standard. This is both a function of the BOD₅ and ammonia that is being discharged.

When DEQ completes a TMDL related to dissolved oxygen, it is possible that treatment plants will be required to reduce their discharge ammonia load. This would involve some level of nitrification at the plant. The TMDL process is typically a lengthy process and new requirements will not be forthcoming soon. For planning purposes, providing summer nitrification should be anticipated for future plant footprint requirements. The alternatives considered for addressing capacity needs identified in Chapter 4 are summarized in Chapter 6. For liquid treatment, alternatives were evaluated assuming the need for future summer nitrification. The scope of the dissolved oxygen issue is not defined. For planning purposes, a dry weather seasonal limit could be anticipated, especially for the initial limit.

5.15 Nutrients

Indications of excessive nutrients are present in the Lower Willamette River including exceedances of chlorophyll-a, aquatic weeds and harmful algal blooms. Work completed by USGS and others indicates that the river is likely phosphorous limited which would indicate that future phosphorous limits are possible. The level of chlorophyll-a in the river is currently limited by the lack of light penetration in the water and not the amount of phosphorous in the water. For planning purposes, providing summer phosphorus treatment should be anticipated for future plant footprint requirements. The alternatives considered for addressing capacity needs identified in Chapter 4 are summarized in Chapter 6. For liquid treatment, alternatives were evaluated assuming the need for future summer phosphorous removal. There will likely be a dry weather seasonal limitation.

5.16 Triennial Review

DEQ has initiated the triennial review of Oregon's water quality criteria. One of the highest priorities indicated by the state is to evaluate the potential to more fully use bio criteria to protect aquatic life. Also, the narrative standard related to excessive aquatic plant and algal growth and nuisance phytoplankton growth are high priority areas of review. All of these could result in new or more stringent discharge requirements, but this process will take several years before any clarity on their impact is known. As discussed above, these criteria will primarily influence nutrient requirements.

5.17 Pre-Treatment Limit Evaluation

The City of Wilsonville (City) Wastewater Treatment Plant (WWTP) began a new industrial local limits evaluation in the summer of 2021. It will be the first update since 2004. The City operates a state-approved industrial pretreatment program and must operate the program in compliance with the General Pretreatment Regulations (40 CFR 403). The NPDES permit for the WWTP requires that the City perform a technical evaluation of the local limits and update them if necessary, by February 2022. The new local limits evaluation was conducted to comply with this permit requirement.

The scope of this Wastewater Treatment Master Plan included an evaluation of Pre-Treatment Limits. The purpose of this evaluation was to provide high-level comments and recommendations for consideration in the industrial local limits update. This review is intended to provide continuity with the planning and evaluation of potential WWTP upgrades in the WWTP Master Plan.

Penny Carlo Engineering, LLC (Penny Carlo) was contracted to complete the Pre-Treatment Limit Evaluation for the WWTP Master Plan. Penny Carlo produced a Technical Memorandum titled Wastewater Treatment Facilities Plan 2020 (the Pre-Treatment TM), dated September 13, 2021. That document is provided for ease of reference as Appendix I to this WWTP Master Plan.

The Pre-Treatment TM considered potential pollutants of concern (POC) in the context of:

- the City's local limits in place at the time of the evaluation,
- NPDES permit effluent limits,
- EPA biosolids regulations (40 CFR 503),
- EPA's list of 15 National POCs established by the National Pretreatment Program, and
- the City's design/build/operate agreement with Jacobs Engineering which includes certain limitations on effluent discharged from the City WWTP.

An evaluation was conducted to identify regulatory elements that are the primary drivers for improvements to the WWTP and may trigger the need for industrial source control. Three future POCs for the local limits program were identified:

- Phosphorous.
- Ammonia.
- Methylmercury.

Prior WWTP upsets or problems were also explored. No instances of process interference or pass through of pollutants that would trigger the need for new local limits or updates to current local limits were identified. Influent and effluent metals and priority pollutant data was also reviewed, in addition to biosolids metals results. Results of a program of specialized sampling conducted at the WWTP in July and August 2021 were also evaluated.

Based on this high-level review, the following recommendations were provided:

- The local limits evaluation will need to consider, at a minimum, the list of initial POCs provided in Table 5.8. Other potential POCs may be added during the project, following a more detailed screening of WWTP, industrial, and background (domestic) pollutant data or new data acquired through a sampling program.

- Phosphorous and ammonia are potential future POCs based on anticipation of future TMDLs. A local limit for phosphorous does not need to be considered until a TMDL or effluent limitation is established. A local limit for ammonia does not need to be considered to address the future TMDL, but because it is a national POC (Table 5.8), it must be considered in the local limits evaluation.
- No other new POCs were identified for the local limits evaluation during this review.

Table 5.8 Initial List of POCs for the Local Limits Evaluation

Pollutant	Current Local Limit	NPDES Effluent Limit	Seasonal Ammonia Effluent Limit ⁽¹⁾	EPA National POC	EPA Biosolids Metal ⁽²⁾
Ammonia			✓	✓	
Arsenic	✓			✓	✓
BOD/CBOD		✓		✓	
Cadmium	✓			✓	✓
Chromium				✓	
Copper	✓			✓	✓
Cyanide	✓			✓	
Lead	✓			✓	✓
Mercury	✓			✓	✓
Molybdenum				✓	✓
Nickel	✓			✓	✓
pH	✓	✓			
Selenium				✓	✓
Silver	✓			✓	
TSS		✓		✓	
Zinc	✓			✓	✓

Notes:

(1) City of Wilsonville and Jacobs Engineering DBO contract.

(2) Regulated pollutants for land applied biosolids (40 CFR § 503.13).

Chapter 6

ALTERNATIVES DEVELOPMENT AND EVALUATION

6.1 Introduction

The purpose of this Chapter is to present the methodology and findings of an evaluation of alternatives for wastewater treatment improvements for the City's WWTP. The existing and future needs of the WWTP's processes were defined by comparing the plant's existing condition and capacity, as defined in Chapters 2 and 4, respectively with the projected flows, loads, and regulatory constraints for the recommended alternatives in Chapters 3 and 5, respectively. The Consultant team identified alternatives to be evaluated in collaboration with City staff in a workshop setting and further developed them considering existing and future service flows and loads requiring treatment through 2045. Evaluation of future needs considered operating parameters, space requirements, capital and operation and maintenance (O&M) costs.

Where capacity shortcomings were identified, at least two alternatives were evaluated for each corresponding unit process. Notably alternatives to address gravity thickening and UV disinfection process capacity limitations under future conditions were not considered. The existing backup Trojan UV unit needs urgent replacement due to age and the fact the equipment is no longer supported/serviced by the manufacturer. When this replacement occurs, the capacity of the backup UV unit is expected to increase. Regardless, the capacity of the UV process is predicted to be exceeded after 2040. By that time, both existing (newer) Suez UV equipment and the replacement unit(s) for the backup Trojan system will have exceeded or be approaching their expected service life. Similarly, the GBTs currently operating at the WWTP will exceed their useful life near or before the time capacity of those units is reached. As these technologies are well suited for the existing facility configuration at the WWTP and operations staff are comfortable with these technologies, no alternative evaluation was conducted for these process areas. Necessary facility modifications and equipment costs were considered in developing estimates for replacement of these units. These estimates are presented in Chapter 7 – Recommended Alternative.

Modifications to the existing WWTP evaluated in this Chapter were modeled in BioWin using the calibrated model described in Chapter 4 to evaluate the overall impact of each alternative on WWTP operations. Modifications to the WWTP to meet potential future NPDES permit limitations or prohibitions discussed in Chapter 5 were considered in selecting a preferred alternative, although performance and capacity needs have been based on existing permit conditions.

Chapter 7 presents the combined capacity and condition improvement recommendations, including the timing and estimated cost of improvements.

6.2 Secondary Treatment

As identified in Chapter 4, the secondary treatment process at the WWTP is expected to require additional capacity by approximately the year 2027. This assessment is based on the assumption that the City continues to operate at higher SRTs than necessary to reliably reduce BOD. This higher SRT operational mode was initiated by the operations team to reduce the risk of discharging ammonia at concentrations that could drive reasonable potential, and therefore trigger ammonia limitations in future NPDES permits issued by Oregon DEQ. This analysis has considered the capacity necessary to treat effluent during the planning period (through 2045) assuming that summer ammonia removal (nitrification) and phosphorous removal may be necessary. In the interim before an additional aeration basin is built, the City will likely need to operate at SRTs less than 5 days during the maximum week condition if growth occurs as predicted. Operating at lower SRTs can allow the City to meet current permit limitations and stretch the secondary treatment capacity until upgrades to meet expected demand can be constructed. This section presents alternatives to address these capacity limitations identified in collaboration with City Public Works and operations staff during a September 2021 workshop. The two alternatives considered to increase secondary capacity are:

1. Expansion of the existing conventional activated sludge process.
2. Intensification of the existing treatment process.

6.2.1 Conventional Secondary Expansion

Expansion of the existing secondary treatment process could occur through the addition of an aeration basin or a secondary clarifier. Aeration basin expansion increases capacity by allowing for the same inventory spread over more volume, which results in a lower overall MLSS concentration and lower solids loading rates on the secondary clarifier. Secondary clarifier expansion increases capacity because it spreads the solids loading over more clarifiers, thus decreasing the solids loading rate on each individual clarifier. As described in Chapter 4, by the year 2027 the projected MLSS concentration under MWWWF loading conditions is expected to be approximately 3,900 mg/L which matches the capacity of the existing secondary clarifiers assuming a sludge volume index (SVI) of 150 mL/g.

The construction of a fourth aeration basin would allow for reduction in the MLSS concentration entering the secondary clarifiers, allowing for sludge to settle under future peak flow events. However, the addition of a fourth aeration basin increases the capacity of the secondary process only through approximately the year 2031. At that time, operating conditions in the basins are predicted to result in an MLSS concentration of approximately 3,700 mg/L which matches the capacity of the secondary clarifiers assuming an SVI of 150 mL/g and the higher peak flows associated with the projections for 2031. This predicted MLSS concentration (approaching 4,000 mg/L), suggests adding a fourth secondary clarifier at that time would provide minimal benefit.

A fourth aeration basin may be added immediately adjacent to aeration basin 3, as shown in Figure 6.1. While construction in this area is likely feasible, there are a number of challenges associated with the construction of a new aeration basin in this location. There would only be approximately 15 feet between the outer wall of the new basin and the existing fence line, which is insufficient to accommodate both a sloped cutback and vehicular access. To allow for vehicle access, shoring must be installed near the property boundary to permit excavation and vehicular access around all sides of the new basin. Additionally, the design would need to consider vehicular access around the northeast corner of the new basin to prevent limitations on the

turning radius of vehicles navigating this area. Preliminary assessment indicates that passenger cars and trucks may be accommodated, but larger vehicles may be unable to access the full perimeter of the proposed additional basin. Furthermore, while not located on site, there is a large mound of excavated soil near the property line on the adjacent property (owned by the Oregon Department of Transportation) that must be avoided and protected throughout construction. Lastly, to maintain vehicular access around the basin after backfilling the basin exterior, the surrounding area must be regraded, which will likely require installation of a short retaining wall along the length of the basin at the property boundary.

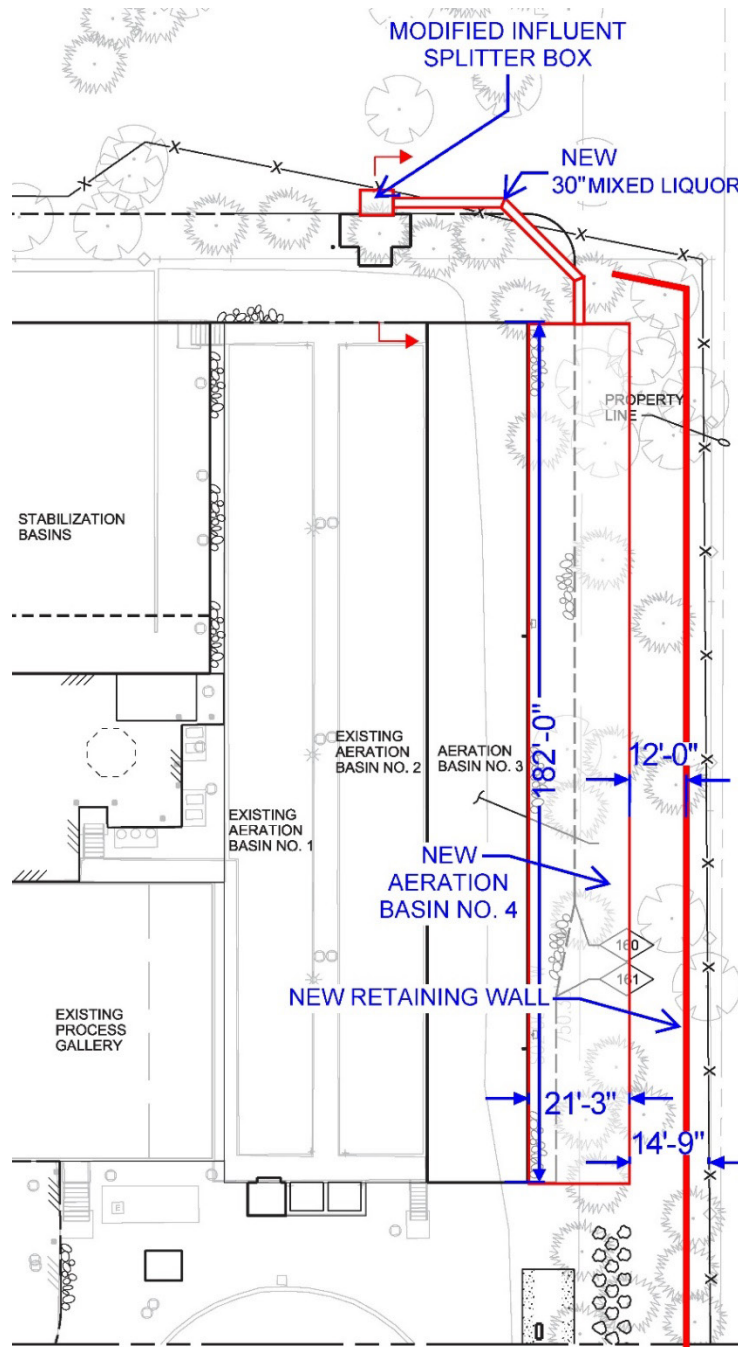

Figure 6.1 Proposed Fourth Aeration Basin Site Plan

In estimating the cost of a new aeration basin, the following assumptions were made:

- The influent splitter box immediately north of the aeration basins can be modified to include a fourth gate to evenly distribute influent between four aeration basins instead of three. A proposed section view of this modification is shown in Figure 6.2.
- The new aeration basin will be constructed identically to the existing aeration basins, with coarse bubble mixing in the anoxic zone, fine bubble aeration diffusers in the aerobic zones, intermediate baffle walls, mixed liquor recycle pumping, basin covers and connections to the odor control system, and identical instrumentation and control systems.
- The retaining wall will be a concrete cantilevered design with a height ranging from 4.5 feet to 12.5 feet. Figure 6.3 depicts the estimated dimensions of the wall and foundation. The wall was assumed to have no additional surge loading except for soil load. If surge is present, the loading and wall design parameters will need to be evaluated by a geotechnical engineer. A 12-foot roadway suitable for small utility trucks is assumed to be constructed around the new aeration basin. These grading and sitework concepts may change based on specific soil conditions, angle of placement, and further geotechnical evaluation during preliminary design.
- The existing blowers will not provide sufficient capacity through the planning period. To meet the 2045 demand, seven 3,000 scfm blowers will be required. This project assumes the addition of one 3,000 scfm blower with the new aeration basin.
- No new stabilization basins will be constructed upstream of the aeration basins.

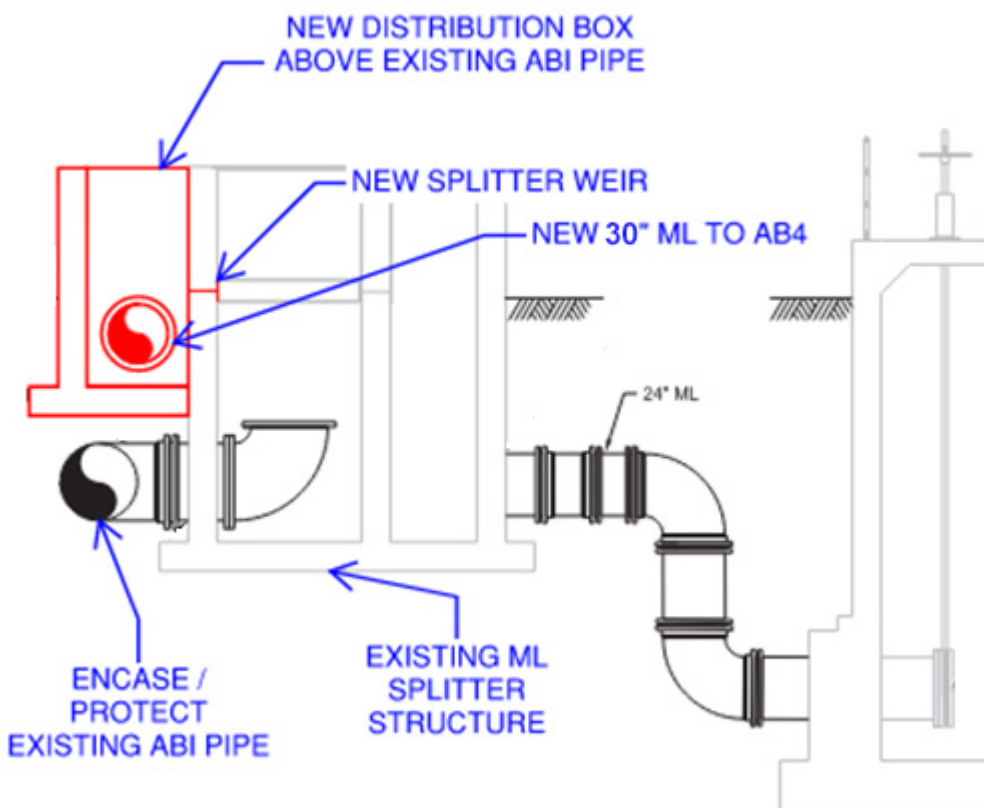

Figure 6.2 Proposed Mixed Liquor Splitter Box Modification (Section)

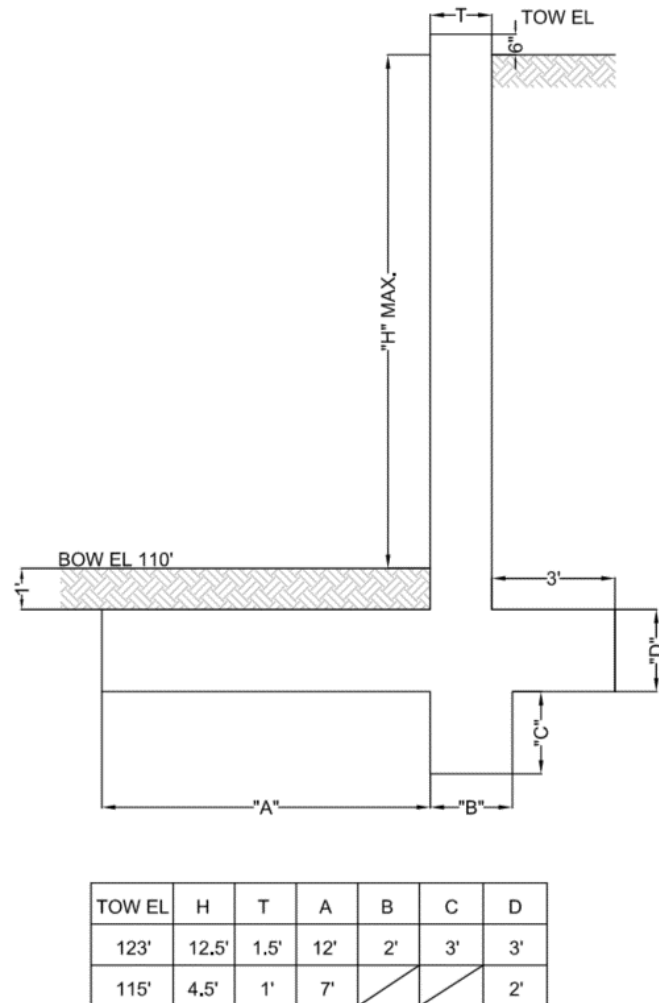

Figure 6.3 Proposed Retaining Wall Dimension

A cost estimate for a new aeration basin is presented in Table 6.1. Additional detail on the cost estimate is provided in Appendix J.

Table 6.1 New Aeration Basin Opinion of Probable Cost

Description	Class 5 Estimate (2023) Accuracy Range: -50% to + 100%
Excavation, Earthwork and Retaining Wall	\$2,317,000
New Concrete Tank and Baffle Walls	\$1,168,000
Blower	\$208,000
Mechanical	\$680,000
Electrical, Instrumentation, and Control Improvements	\$600,000
Total Direct Cost	\$4,973,000
Total Estimated Construction Cost⁽¹⁾	\$8,178,000
Total Estimated Project Cost⁽²⁾	\$10,222,000

Notes:

(1) Assumes 30% Design Contingency, 10% General Conditions, and 15% Contractor Overhead and Profit.

(2) Assumes 25% Engineering, Legal, and Administrative Fees and ENR Construction Cost Index = 13473 (August 2023).

Although building a fourth aeration basin increases the capacity of the secondary process, it does not provide sufficient capacity to meet the projected 2045 loads and does not provide capacity to meet future summer ammonia and phosphorus limits. As mentioned previously, additional secondary clarifiers are not expected to provide more secondary treatment capacity given the high (~4,000 mg/L) MLSS concentrations predicted to be produced even with a fourth aeration basin in operation. Given the site limitations, construction of a fifth aeration basin is not feasible, thus further conventional expansion cannot provide sufficient secondary capacity through the planning period.

6.2.2 Intensification

The second option considered to provide additional secondary capacity is through intensification. Intensification of the existing biological process can be achieved through various means including processes like BioMag or integrated fixed film active sludge (IFAS) that increase inventory through the addition of a ballast or a membrane bioreactor (MBR) which operates at a higher MLSS concentration and replaces secondary clarifiers with membrane separation technology. This section provides an overview of these three different intensification technologies along with more detailed discussion of the selected representative technology.

6.2.2.1 BioMag

BioMag is a process that allows for a higher biomass concentration than conventional suspended growth by physically improving settling velocities with a weighted ballast material. The BioMag® system is patented and offered by Evoqua Water Technologies in the United States.

This process uses very small, dense particles of magnetite introduced into the aeration basins. Magnetite is Fe_3O_4 , an inert form of iron ore with a specific gravity that is five times that of biological sludge. The biomass attaches to the magnetite in the sludge, which drastically improves the settling velocity of the mixed liquor suspended solids. The increase in settling velocity allows the activated sludge process to be designed with higher MLSS concentrations, resulting in the need for much smaller bioreactors and clarifiers volumes. WAS from the secondary process is pumped, screened and then conveyed to a shear mill and a magnetic recovery drum to recover and reuse the magnetite. A sample process schematic is shown in Figure 6.4.

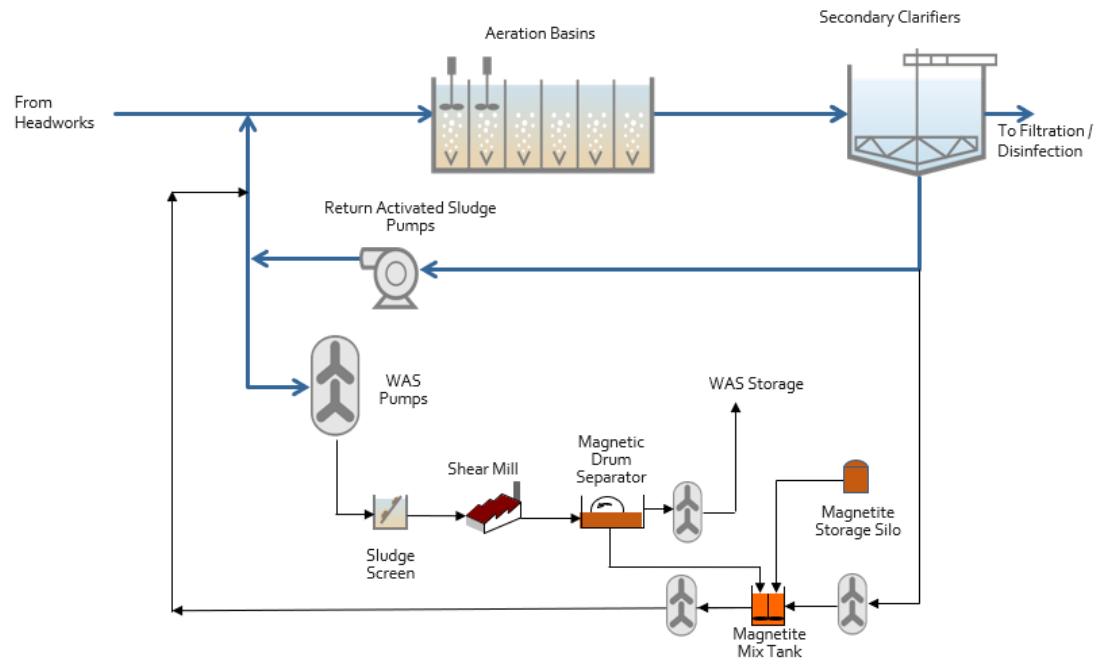

Figure 6.4 Sample BioMag® System Schematic

6.2.2.2 IFAS

The IFAS process is another variation of an intensification process that allows for a higher biomass concentration than a conventional suspended growth culture.

Intensification is accomplished by adding media (e.g., pieces of plastic media, ropes, or sponges) to the aeration tank to provide “fixed film” type surfaces on which bacteria can attach and grow with the intent of increasing the overall biomass inventory in the aeration tank than would typically be sustainable in a conventional activated sludge suspended growth process. Most IFAS media systems are proprietary, but there are many suppliers allowing competitive selection of IFAS illustrated in the examples presented in Table 6.2 and Figure 6.5. To avoid mounding of media at the end of the aeration basins, the design needs to maintain an adequate velocity through the basin. In addition to media screens, further modifications to the basin to allow for longitudinal flow may be required.

Table 6.2 Suppliers of IFAS Systems Nitrogen Removal Alternative Evaluation, City of Porterville

Free (Dynamic) Media		Fixed Media (Ropes, Nets, or Sheets)	
Company	Media	Company	Media
M2T Technologies	Linpor™	Ringlace Products Inc.	Ringlace™
AnoxKaldnes	Kaldnes™	Entex Technologies Inc.	BioWeb™
Siemens/US Filter	Agar™	Brentwood Industries	AccuWeb™
Infilco Degrement Inc.	Hydroxyl™	GLV/Dorr-Oliver/Eimco	Clartec™
Entex Technologies	BioPortz™	BioProcess Technologies Ltd.	Looped Cored Media (LCM™)

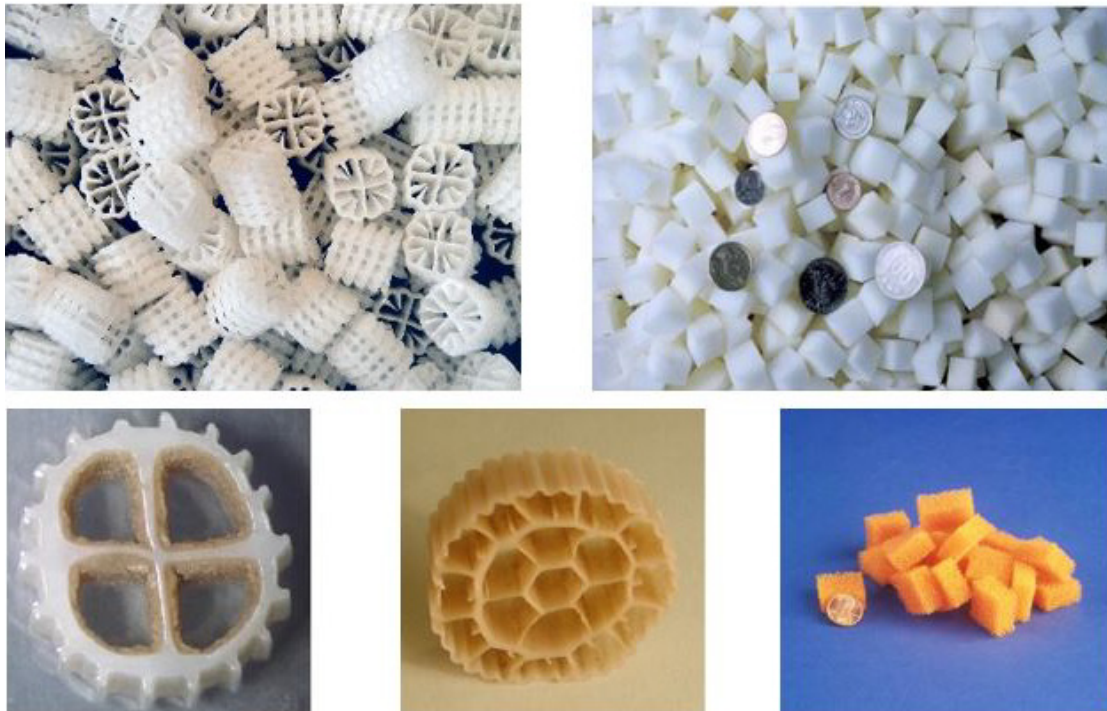

Figure 6.5 Examples of “Wagon Wheel” and Sponge Media Used in an IFAS Technology

6.2.2.3 MBR

MBRs are a combination of activated sludge reactors and membrane facilities. Membrane systems are pressure driven solids separation processes, which use membranes with extremely small pore spaces to remove pollutants. Typically, a vacuum is applied to a header pipe connected to the membranes, which draws the treated effluent through the membranes and into the pump. These systems can be used to replace clarifiers and filtration in the activated sludge process. Without the limitations set by solids flux in secondary clarification, the mixed liquor can be more concentrated (up to 10,000 mg/L) than with conventional activated sludge, which reduces the size of the activated sludge process. MBRs produce a high-quality effluent that is superior to the effluent from both final clarification and tertiary filtration. A sample process schematic is shown in Figure 6.6.

Due to the small pore size of the membrane, the influent will need to pass through fine screens (one millimeter opening) prior to the aeration tanks. Membrane systems typically have a higher operation and maintenance cost than a traditional activated sludge system due to higher power requirements (from the higher aeration and pumping demands), the higher chemical costs (due to the need for periodic membrane cleanings), and the need for periodic membrane replacement (every six to ten years).

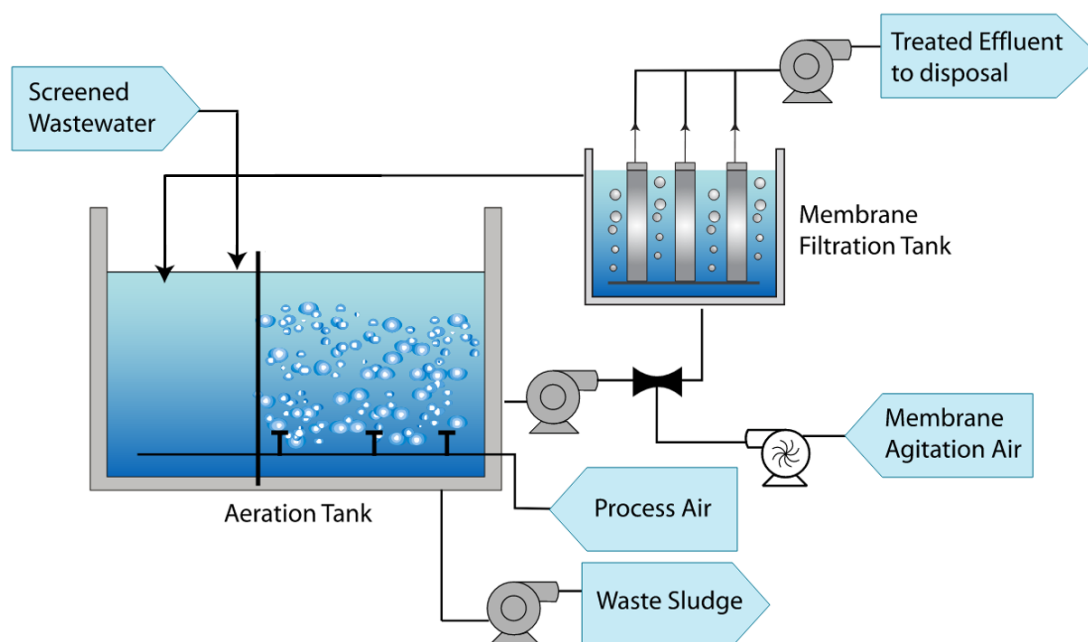

Figure 6.6 MBR Schematic

6.2.2.4 Selected Intensification Alternative

An initial evaluation of these three alternative technologies suggests that even with a fourth aeration basin, and secondary clarifier IFAS and BioMag will not be able to provide sufficient capacity for the design year flows and loads and future permit requirements for summer nitrification and phosphorus removal. With a fourth aeration basin, the MBR process will be able to provide sufficient capacity. Additionally, to produce a filterable floc, the MBR process will need to nitrify year-round and thus can meet the anticipated future requirements for summer

nitrification. Future summer phosphorus limits can be met with the MBR by the addition of coagulants such as alum to the aeration basin.

In addition to capacity considerations, the implications of the intensification technologies on the solids processing were also compared. While the IFAS and MBR technologies are anticipated to have little change on the solids process, the potential for magnetite to be present in the waste activated sludge from a BioMag process needs to be considered. The BioMag vendor was contacted and reports that no BioMag facilities exist that process undigested solids in a thermal dryer, and thus the fate of the iron in the sludge is unclear. For coal processing facility applications, once iron concentrations reach approximately 5 percent in the dried solids, the iron can oxidize, reheat and smolder. Additionally, the presence of iron in the sludge will likely increase the wear on pumps and other mechanical equipment used for processing solids, including the dryer.

Table 6.3 summarizes the comparison of the three considered intensification technologies. Given uncertainty with magnetite solids impacts on the drying process, and since the IFAS and BioMag processes are not anticipated to provide sufficient capacity to treat the projected 2045 flows and loads while providing for summer nitrification and phosphorus removal, the MBR process was selected. Identifying the MBR process in the CIP does not preclude the City from revisiting intensification options (including BioMag) prior to commencing preliminary design.

Table 6.3 Comparison of Intensification Technologies

	BioMag	IFAS	MBR
Additional facilities required.	<ul style="list-style-type: none"> Magnetite separator. 4th aeration basin. 4th secondary clarifier. Additional blower capacity. 	<ul style="list-style-type: none"> Significant basin modifications. 4th aeration basin. 4th secondary clarifier. Additional blower capacity. 	<ul style="list-style-type: none"> Fine screens. 4th aeration basin. Membrane tanks. Additional blower capacity.
Provides sufficient capacity for anticipated 2045 loads with summer nitrification and phosphorus removal.	<ul style="list-style-type: none"> Almost 	<ul style="list-style-type: none"> No 	<ul style="list-style-type: none"> Yes
Anticipated interactions with the solids processing system.	<ul style="list-style-type: none"> Yes: Iron concentrations in the biosolids exceeding 5% could cause smoldering. 	<ul style="list-style-type: none"> No 	<ul style="list-style-type: none"> No

The calibrated BioWin model was used to evaluate how MBRs could expand the capacity of the existing plant. Due to the relatively uniform solids concentration in the aeration basins and the RAS, the MBR basins would operate in a plug flow mode as opposed to the solids contact mode used by the existing aeration basins. The existing solids contact tanks could serve as unaerated selectors for the process, allowing for alkalinity to be recovered through denitrification. With this operational configuration, four aeration basins and five membrane tanks will be required to provide capacity for the 2045 flows and loads. Since the secondary clarifiers will no longer be required, the five new membrane tanks could be constructed over one of the existing secondary clarifiers as is shown in Figure 6.7. New fine screening will be required to protect the membrane units and could be located between the existing Dewatering/Drying Building and the stabilization basins.

In addition, blower capacity will need to be expanded to meet projected 2045 loads. To provide the aeration air required for the 2045 loads, a seventh blower will need to be provided at 3,000 scfm as discussed in section 6.2.1. The expected location of the seventh blower is shown in Figure 6.8. The seventh blower is assumed to be added when the new aeration basin is constructed. The existing six 1,700 scfm blowers would also need to be replaced with 3,500 scfm blowers to provide the predicted aeration capacity required. This is anticipated to occur in a phased manner over the planning period.

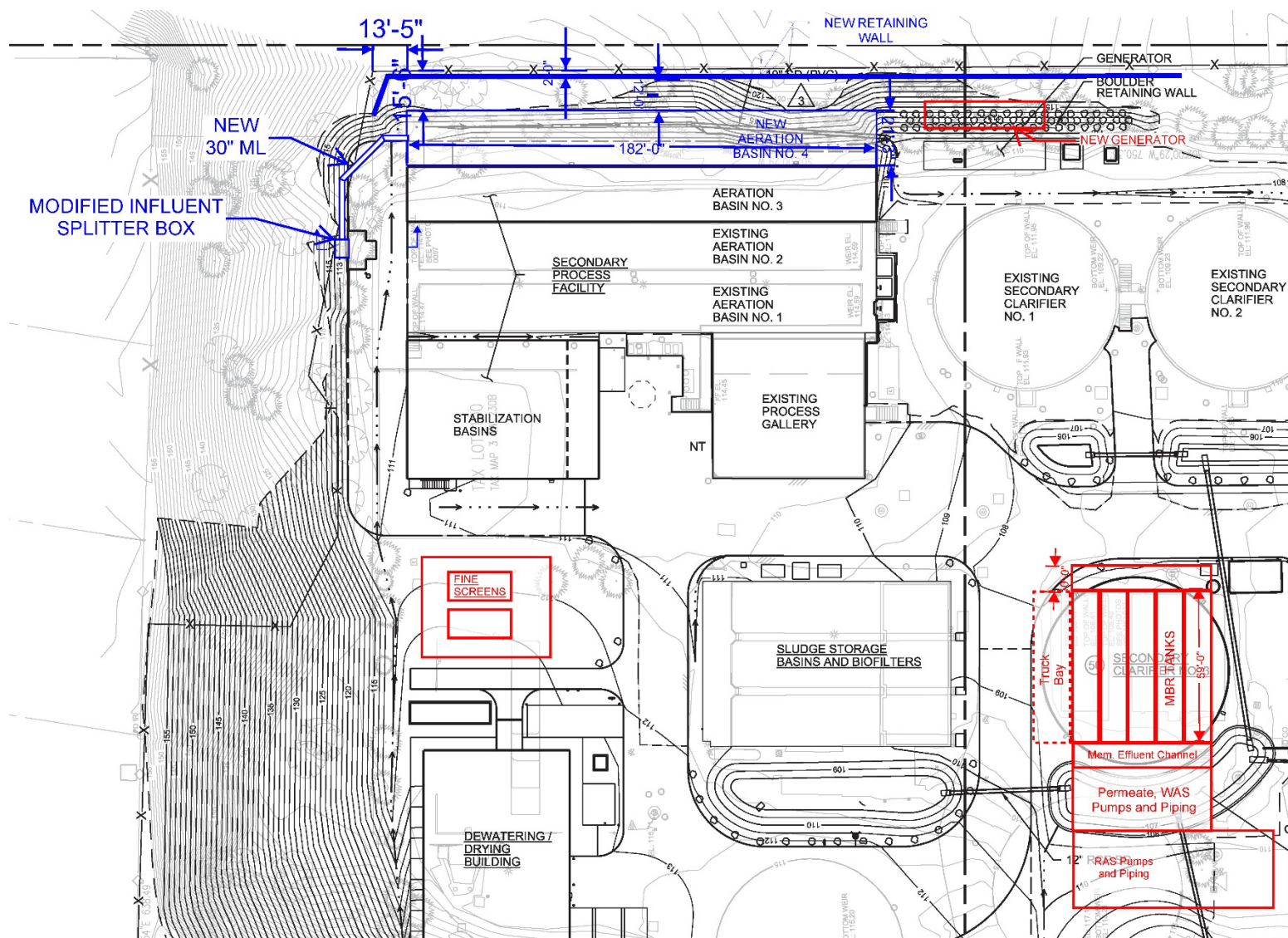

Figure 6.7 Potential MBR and Fine Screen Facility Site Plan

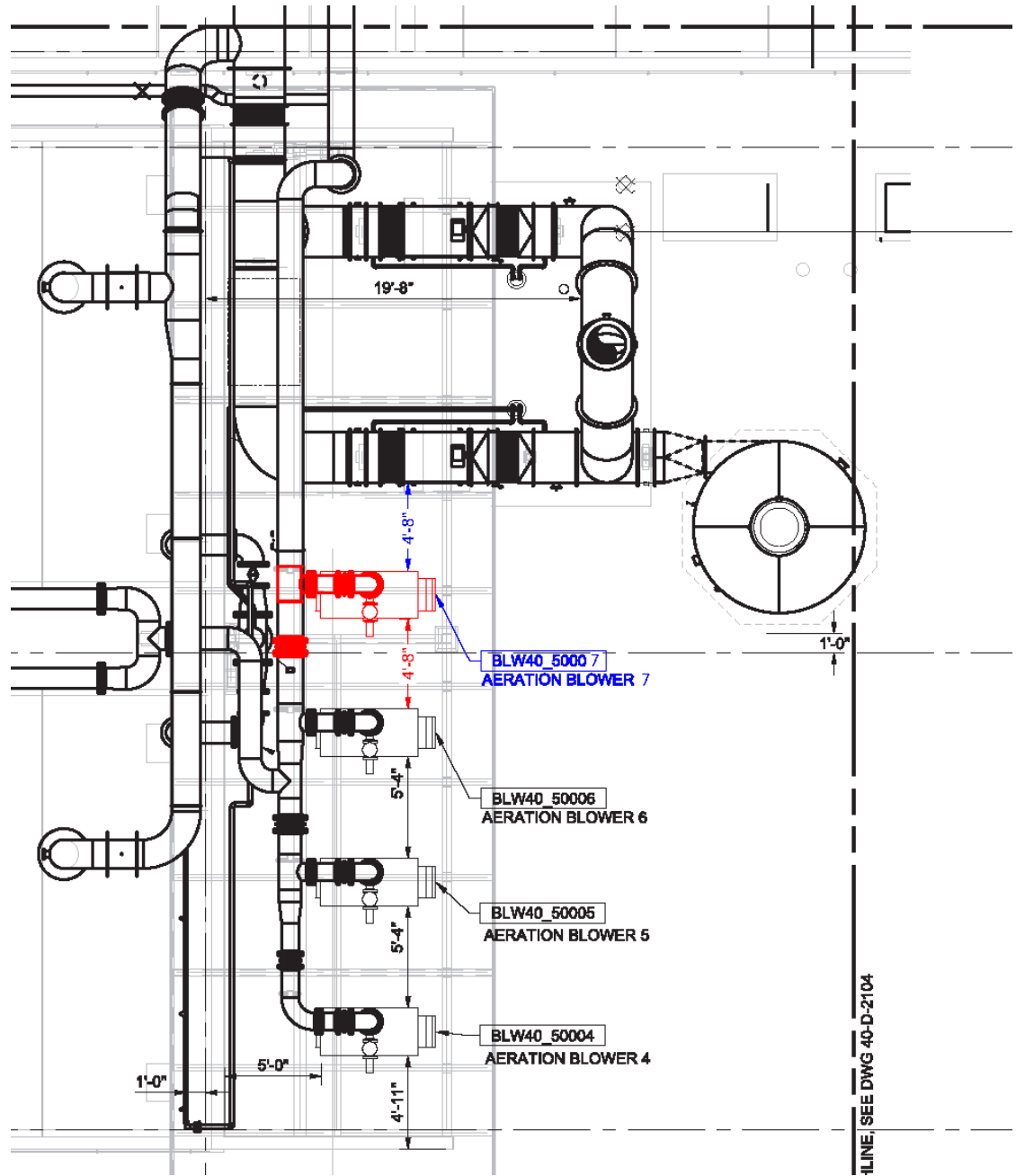

Figure 6.8 Proposed Modifications to Blower Canopy

Planning level costs were developed for this MBR approach as presented in Table 6.4. Additional detail on the cost estimate is provided in Appendix J. Given site limitations and uncertainty with the compatibility of magnetite from the BioMag process with current solids handling practices, the MBR intensification alternative was selected to provide necessary secondary treatment capacity to address predicted loads through the year 2045.

Table 6.4 MBR Opinion of Probable Cost

Description	Class 5 Cost Estimate (2023) Accuracy Range: -50% to + 100%
Site Work + Yard Piping + Stormwater Infrastructure	\$4,095,000
Fine Screens	\$3,339,000
Fourth Aeration Basin + Retaining Wall + Blower ⁽¹⁾	\$4,973,000
6 x 3500 scfm Blowers	\$1,250,000
MBR Tank, RAS/WAS/Permeate Pumping	\$17,492,000
Electrical Upgrade	\$4,950,000
Electrical, Instrumentation, and Control Improvements	\$7,875,499
Total Direct Cost	\$43,975,000
Total Estimated Construction Cost⁽²⁾	\$72,317,000
Total Estimated Project Cost⁽³⁾	\$90,396,000

Notes:

(1) See Table 6.1 for additional details.

(2) Assumes 30% Design Contingency, 10% General Conditions, and 15% Contractor Overhead and Profit.

(3) Assumes 25% Engineering, Legal, and Administrative Fees and ENR Construction Cost Index = 13473 (August 2023).

6.2.3 Secondary Expansion Phasing

MBRs typically have a higher operation and maintenance cost than conventional treatment due to the need to periodically replace the membranes, the chemicals required for the membrane cleaning, the increased pumping requirement for the RAS and permeate, and for the increased aeration energy required to scour the membranes. Due to these higher operation and maintenance costs, it is in the City's best interest to phase intensification of the secondary treatment process. The secondary process capacity expansion could be phased as follows:

- Construct aeration basin 4 (around the year 2027): Build the fourth aeration basin along with the addition of the seventh blower.
- MBR Phase 1 (around the year 2031): Build the RAS, WAS and permeate pumping and blower building along with five MBR tanks in the location of one of the existing secondary clarifiers. For this initial phase, add membranes to only three of the membrane tanks. Build the fine screening and replace three of the existing 1,700 scfm blowers with 3,500 scfm blowers. Two aeration basin and one solids contact tank will initially be operated with three of the MBR tanks. To treat the flow from the two aeration basins directed towards the membrane tanks, five membrane cassettes will be added to three of the membrane tanks (a total of 15 membrane cassettes). The two existing aeration basins and two secondary clarifiers will continue to provide conventional treatment.
- MBR Phase 2 (around the year 2038): Three total aeration basins and one solids contact tank will be operated with three MBR tanks. To treat the flow from the three aeration

basins directed towards the membrane tanks, one additional membrane cassettes will be added to each of the three membrane tanks (three additional membrane cassettes, bringing the total installed to 12). Additionally, two of the existing 1,700 scfm blowers will be replaced with 3,500 scfm blowers. The remaining solids contact tank, one existing aeration basin and two secondary clarifiers will continue to provide conventional treatment.

MBR Phase 3 (around the year 2043): All the aeration basins and solids contact tanks will be operated with five MBR tanks. To treat the flow from the four aeration basins six membrane cassettes will be added to the fourth membrane tank (bringing the total one additional membrane cassette will be added to the three MBR tanks with membranes and seven cassettes will be added to the two new MBR tanks (bringing the total number of installed cassettes to 26). Additionally, the one remaining 1,700 scfm blowers will be replaced with a 3,500 scfm blower.

The phased approach to intensification with MBR technology positions the City to address needs beyond projected 2045 loading, or if limitations on effluent discharges to the Willamette River become more stringent. Both solids contact basins could be operated as external selector zones, and the MLSS from all four of the aeration basins could be routed to the five MBR tanks.

The final phase of the MBR expansion is as large as it is primarily due to the elimination of the CAS side of the process. For MBR Phases 1 and 2, the MBR process is only treating approximately 50 percent of the peak flow with the rest of the peak flow being handled by the CAS side of the process. Once the CAS side is eliminated, additional membrane capacity is required to handle this additional peak flow. In addition, with this alternative, Jacobs identified hydraulic limitations that limit the peak RAS flow to only 26.72 mgd (*Hydraulic Analysis* TM, August 31, 2023, Jacobs). According to the Jacobs *Hydraulic Analysis* TM (Appendix H), this 26.72 mgd RAS flow can be accommodated at the WWTP with “moderate” upgrades to the existing stabilization basin/splitter structure, aeration basins, and yard piping. Jacobs also notes that RAS flow of 70.4 mgd (4 times PHF) can be accommodated at the WWTP with the addition of a lift station, which would require significantly raising the aeration basins and associated stabilization basin/splitter structure, and significantly upsizing yard piping. Additional pumping and upsizing of yard piping is not desirable, thus options for configuring secondary treatment upgrades were assessed that would limit RAS flow to 26.72 mgd.

Even at this “limited” future RAS flow, the projected solids mass flux on the membrane tanks controls capacity requiring even more membrane surface area. If peak flows to the plant could be equalized (or reduced) so that the 2045 PHF would equal the projected 2045 PDF, the solids flux limitations would likely be eliminated and the entire system could be smaller, potentially saving approximately \$10,000,000 in project cost. If the final phase of the MBR process could also be eliminated due to lower growth projections and peak flow reductions, the City could potentially save approximately \$17,000,000 in total project costs for the MBR process as presented in Table 6.3 which includes three phases. These savings could be realized from building fewer membrane tanks, constructing smaller RAS/WAS and blower buildings and installing fewer membranes. It does not include potential savings from smaller yard piping between the existing headworks, future fine screen facilities, stabilization basins, and aeration basins as well as reducing the diameter of required RAS piping.

It is advised the City consider opportunities for attenuation of peak flows within their collection system with the goal of reducing future PHF. This may best be achieved through exercise of the City's collection system hydraulic model. Confirming estimates of wastewater flow contributions from currently undeveloped lands within the service area during the planning period is also advised. As the 2014 Collection System Master Plan established the unit flow factors for future growth within the service area, these have a direct impact on the predicted flow anticipated to be received at the WWTP. It is expected the City will be updating their Collection System Master Plan within the next few years. This offers an opportunity to both confirm expected wastewater generation and consider possible attenuation of peak flows within the collection system.

6.3 Tertiary Treatment

During the dry weather season, the City's NPDES permit limits monthly effluent TSS concentrations to 10 mg/L. The City's agreement with their DBO firm requires that effluent TSS concentrations need to be half of the NPDES permit requirement.

With the installation of stainless-steel media in 2019 to replace the old cloth media in the disc filters, the rated capacity of the filters was reduced from a peak flow of six mgd per filter bank to only 3.75 mgd. However, operations staff has stated that the stainless-steel media is much more resistant to wear and failure, and that identifying points where the media has failed is very easy. Despite this seeming operational and maintenance advantage, additional capacity is expected to be needed around the year 2032 to provide full treatment of the MMDWF with one disc filter out of service or in backwash mode.

As discussed in the previous section, by the year 2031 a portion of the treatment plant flow will be receiving membrane treatment thus alleviating the capacity limitations on the tertiary filtration process. Given the expected timing of the membrane intensification process, expansion of the existing tertiary filtration process is not recommended.

6.4 Effluent Cooling – Cooling Towers and Other Considerations

As summarized in Chapters 4 and 5, the cooling tower technology's ability to cool the water is dependent on the wet bulb temperature. For wet bulb temperatures less than or equal to the design of 68F, the current system can provide cooling sufficient to meet the current thermal load for maximum weekly summertime flows of 3.7 mgd or less. If instead the maximum wet bulb temperatures are more like the maximum predictions from the ASHRAE handbook of 73.1F, the current system can only provide cooling sufficient to meet the current thermal load limit for maximum weekly summertime flows of approximately 1.8 mgd or less.

Since the maximum weekly summer flows between the low flow months of July and August are anticipated to reach 4.1 mgd by the year 2045, additional strategies would be required to comply with this limit by the design year. These strategies could include:

- **Reuse:** The City currently has effluent filters and plans for a future MBR facility which will allow for the production of Class A reclaimed water. For wet bulb temperatures equal to the design wet bulb temperature of 68F, the City would need to provide reuse for approximately 0.4 mgd of maximum weekly summertime flow during the months of July and August under projected 2045 effluent flow conditions. If instead the wet bulb temperature was as high as 73.1F, the City would need to provide approximately 2.3 mgd of reuse to comply with the effluent thermal load limits.

- **Shading:** Several utilities in Oregon, such as Clean Water Services and the City of Medford, have a shade program in place to help them comply with their effluent thermal load limit. Through these programs, the utilities plant trees along rivers to provide natural shading and thermal load credits which can be used to meet their effluent limits.
- **Chillers:** A chiller with a capacity of 700 tons downstream of the existing cooling tower would provide the ability to cool the water below the wet bulb temperature and allow the City to comply with their effluent thermal load limit during all but the most extreme heat conditions under projected 2045 effluent flow conditions.

Given the impact of the actual wet bulb temperature on the maximum allowable weekly flows, careful attention should be paid to the flows and actual wet bulb temperatures during these months. As flows increase, the City can determine if strategies such as reuse and shading can provide sufficient cooling to meet the anticipated effluent thermal load limit or if energy intensive technologies such as chillers would be required.

Chillers are a technology deployed by industries and municipalities throughout North America, including at wastewater treatment plants. They are considered a proven, reliable technology for cooling. Chillers require power input to further cool effluent as compared to a more passive process like evaporative cooling employed by cooling towers. As such operating costs (electricity) are higher. Considering projected 2045 effluent flows, a chiller unit sufficient to provide confidence that the City can avoid exceedances of the ETL limit for all conditions except for the most extreme 1 in 100-year anticipated heat wave, may cost approximately \$3.5-4.5 million to design, procure and install. Given the availability of options including effluent reuse and shading, it is understood the City wishes to avoid installing chillers if at all possible. The City intends to further investigate these potential options and monitor wet bulb temperature. If reuse or shading is not a viable, or more cost-effective option, the City may need to install chillers to address effluent cooling needs.

In addition to the cooling capacity limits dictated by the wet bulb temperature, the existing effluent cooling system is expected to run out of hydraulic capacity by 2036. However, prior planning anticipated this need and space for an additional cooling tower unit (with similar size and design parameters as the existing units) exists on-site and can be added to ensure there is sufficient capacity to cool effluent through the end of the planning period. There is adequate space to install a third unit, including a flanged connection to facilitate installation, as shown in Figure 6.9. Planning level costs for an additional cooling tower are presented in Table 6.5. The City should begin to track wet bulb temperatures and as flows increase determine whether a third cooling tower will provide cost effective cooling. Additional detail on the cost estimate is provided in Appendix J.

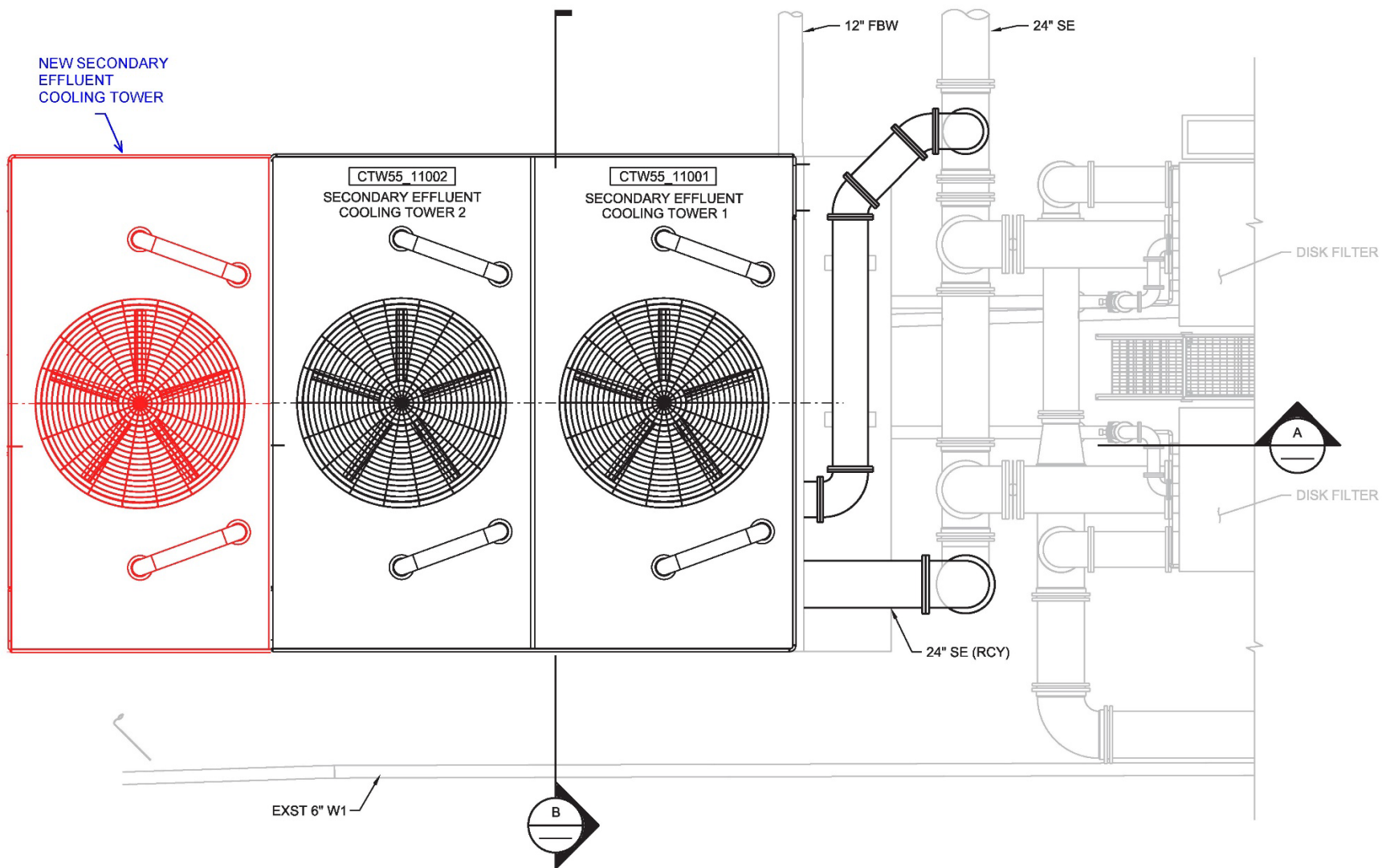

Figure 6.9 Proposed Cooling Tower Layout

Table 6.5 New Cooling Tower Opinion of Probable Cost

Description	Class 5 Cost Estimate (2023) Accuracy Range: -50% to + 100%
Demolition	-
Mechanical	\$250,000
Electrical, Instrumentation, and Control Improvements	\$62,000
Total Direct Cost	\$312,000
Total Estimated Construction Cost⁽¹⁾	\$514,000
Total Estimated Project Cost⁽²⁾	\$642,000

Notes:

(1) Assumes 30% Design Contingency, 10% General Conditions, and 15% Contractor Overhead and Profit

(2) Assumes 25% Engineering, Legal, and Administrative Fees and ENR Construction Cost Index = 13473 (August 2023).

6.5 Solids Handling

The City has committed to producing United States Environmental Protection Agency Class A biosolids at the facility using a wastewater solids dryer. The capacity evaluation of the existing dryer unit presented in Chapter 4 concluded the nameplate capacity of the dryer unit will provide solids drying capacity through 2045 with the following assumptions:

- The secondary treatment process at the City's WWTP consistently produces a sludge of appropriate quality to allow the existing dryer unit to perform optimally (consistent with expected solids loading rates and sludge characteristics stipulated by the manufacturer of the unit).
- The dewatering centrifuges produce a sludge feed to the dryer greater than 18 percent solids.
- Dewatering and drying operate 24 hours per day, 7 days per week, in 2045.

The WWTP secondary treatment and sludge dewatering processes have not been performing consistently since the 2019 thermal event due to several factors detailed further in this section. It is difficult to assess dryer performance if secondary treatment has not been operating to meet the assumptions summarized above. More detail on secondary treatment facilities and capacity is provided in Chapter 4.

6.5.1 Dewatering

Centrifuges dewater thickened WAS prior to solids drying. The capacity assessment findings presented in Chapter 4 concluded that the centrifuges have sufficient capacity with all units in operation performing within stated minimum performance criteria. These criteria include:

- The maximum solids loading rate to a single centrifuge is 1,000 pounds total solids (TS) per hour, per the manufacturer's design criteria.
- The maximum hydraulic loading rate to a single centrifuge is 50 gpm, based on discussions with the City.
- The centrifuges achieve a solids capture of approximately 90 percent and dewater solids to between 18 and 20 percent TS.
- The centrifuges run 24 hours per day, seven days per week.
- The centrifuges must be capable of dewatering the maximum week solids load with one unit out of service.

Based on these criteria, the City has sufficient dewatering capacity through the year 2045, with one unit out of service. Chapter 4 documents the capacity of the existing units but that evaluation did not consider equipment age and expected service life. The centrifuges were refurbished in 2021 but were installed when the plant underwent major upgrades in 2014. In 2045, the existing units will have been in service for at least 30 years. The City should plan for their replacement. At the time of replacement, the City should evaluate the capacity of those units based on updated solids projections.

Further, performance issues with the existing centrifuges may be the primary driver of equipment replacement timing. Since the refurbishment in 2021, the units have struggled to achieve a solids capture rate of 90 percent or achieve consistent performance, which inhibits continuous operation of the dryer. Study of the liquid and solid stream processes is advised to identify opportunities to optimize centrifuge performance. This may allow the City to extend the time before replacement with new (potentially higher capacity) units will be required. Alternatively, the City may need to consider replacement of the units with similar or higher capacity units sooner.

The secondary process was modified in 2020 and has experienced extended periods during which mixed liquor concentrations have been elevated above typical ranges for conventional activated sludge or extended aeration processes. Given these complications with secondary process operation and performance issues with the centrifuges, it is advised the City study the secondary treatment and dewatering processes to confirm that the assumptions and conclusions regarding centrifuge capacity may be relied upon. Without uninterrupted operation of these processes over an extended time to allow analysis of performance data, it is difficult to eliminate variables contributing to performance of the solids handling equipment (both centrifuges and dryer).

Therefore, Carollo recommends the City consider:

- Renting portable dewatering equipment (belt filter press [BFP] or centrifuges) and begin processing WAS from the secondary process to reduce MLSS to more typical concentrations.
- Experimenting with different polymer chemicals or removing polymer addition altogether from the secondary process to evaluate effect on centrifuge performance.
- Undertaking polymer chemical experimentation would be one element of a study of the solids treatment, dewatering and solids drying processes described in Section 6.5.3.

Until the performance of the centrifuge units can be analyzed using data collected over a period of several months of continuous, reliable operation, the limitations of the existing units remains unclear. Therefore, this alternatives analysis does not consider dewatering technology options. A belt filter press or screw press could also be used for solids dewatering. Both of those technologies require significantly more footprint, process fewer solids given a comparable footprint, and would likely not achieve the same cake solids concentrations as the centrifuges. However, they would require less electrical power to operate and may save money on polymer consumption. For budgeting purposes, an opinion of probable cost for replacing the existing centrifuges is provided in Appendix K. Timing of that equipment replacement will be dependent upon performance of the existing units. Replacement sizing will be based on an assessment of capacity needs over the life of the new centrifuge units.

6.5.2 Solids Dryer

The existing sludge dryer, installed as part of the 2014 WWTP improvements project, is a paddle dryer system manufactured by ThermaFlite. Thermaflite filed for Chapter 7 bankruptcy in 2016 and its patents were subsequently sold to BCR, Inc. (BCR). In April 2019, the dryer experienced a fire that caused extensive damage to the equipment. A subsequent condition assessment in 2019 identified the dryer as being in extremely poor condition. Extensive rehabilitation was performed on the unit in 2020 and the dryer was returned to service in February 2021. After approximately 7 months of service, the dryer failed again due to a leaking rotary joint and a damaged seal that allowed air into the dryer. Operations continues to work with BCR to replace parts, revise the design, and troubleshoot operations, but the dryer continues to malfunction. When the dryer was not functional, raw dewatered solids were trucked offsite to Coffin Butte Landfill. The dryer has been repaired and is operating satisfactorily as of February 2023.

A potential ongoing issue with the existing paddle dryer is the nature of the solids produced by the secondary treatment system. Aeration systems without primary treatment tend to create a “sticky” sludge, particularly during winter months when an extended solids retention time may be required resulting in an increased “sludge age”. Wastewater solids generally experience a glue-like plastic phase in the 55 to 75 percent dry solids range, but secondary solids produced in an extended aeration system have a plastic phase through a larger range of solids content. As a result, the mechanical torque required to transfer solids through rotary equipment like a paddle dryer will be higher than other types of sludges and the dryer likely requires a considerable safety factor to achieve the rated capacity.

It was observed that during a plant upgrade in 2020, during which portions of the secondary process were taken offline, and again during periods when the solids dryer was out of service, solids were retained in the secondary process for a longer period than the design intent of the facility. Retaining solids in the aeration basins resulted in MLSS concentrations as high as the 8,000 to 9,000 mg/L range and SRTs greater than six days. These ranges can be compared to the desired operating conditions of maximum MLSS concentrations ranging from 3000 to 4000 mg/L and SRTs ranging from five to six days.

Whether immediate replacement of the dryer unit is preferred, or it retains significant remaining useful life, the City will eventually need to replace the unit.

Given the City’s commitment to solids drying as the preferred process to achieve Class A biosolids, this alternatives evaluation has been prepared focusing on thermal drying options only. The current practice of indirect drying is evaluated as well as direct drying technologies such as belt or drum dryers. Belt and drum dryers have a more robust record of performance at wastewater facilities, thus a switch to either of these technologies would likely result in improved solids drying performance. However, every solids processing technology has pros and cons. Biological, solar, and microwave drying technologies are also available and could be evaluated in the future, although those technologies are less popular at wastewater facilities due to technology maturity and/or footprint considerations.

Solids drying technology has benefits for plants with small footprints and Class A goals, such as the City’s WWTP. Presumably, these were the primary reasons for selecting this technology when the plant was upgraded and the current DBO contract was executed. However, solids drying is labor-intensive, involves significant housekeeping, must address hazardous and odorous air conditions, and (most importantly) carries the risk of thermal events such as fires.

These drawbacks can be managed for a successful drying application, but the risk will always be present.

This report evaluated the following alternatives to revise and improve the drying system:

1. Continue operating the existing BCR paddle dryer and defer replacement.
2. Modify the existing Dewatering and Drying Building to accommodate a different solids dryer technology or a redundant dryer.
3. Construct a new dryer building with a different solids dryer technology.

6.5.2.1 Alternative 1 - Continue Operating Existing BCR Paddle Dryer

It may be possible to continue working with BCR to achieve reliable service with the existing dryer. If this alternative is selected, an updated Solids Management Plan could be beneficial. The revised plan could include agreements with nearby municipal wastewater treatment facilities, compost facilities, or other entity that could receive dewatered cake during dryer downtimes. Continuing the current practice of landfilling may be an acceptable option for the short-term but shifts in the regulatory environment may make solids landfilling illegal, similar to the State of California where solids landfilling is currently illegal.

6.5.2.2 Alternative 2 - Modify Existing Dewatering and Solids Dryer Building to Accommodate a Different Solids Dryer Technology or a Redundant Dryer

While the current dryer is out of service, the City wanted to explore other options to increase the reliability or performance of their solids drying operation. Three options are discussed below to reuse or retrofit the existing Dewatering and Solids Dryer Building to support a different solids dryer technology or a redundant dryer.

Alternative 2a - Replace Existing Solids Dryer with a Similar Unit from a Different Manufacturer

It may be possible to replace the existing BCR solids dryer with an equivalent unit from a different manufacturer. Andritz, Haarslev, Komline-Sanderson, and others manufacturer similar indirect-type dryers. An Andritz paddle dryer was used to develop a potential configuration that would fit within the existing Dewatering and Drying Building as shown in Figure 6.10, but other indirect-type dryer manufacturers may also be considered during preliminary design. The replacement unit is expected to have a similar footprint as the existing dryer, but the roof of the building would likely need to be revised to accommodate the increased height of the new unit.

An alternative solids management protocol would be required during construction of this alternative. Like Alternative 1, an updated Solids Management Plan is recommended to temporarily manage dewatered cake while the existing dryer is being replaced.

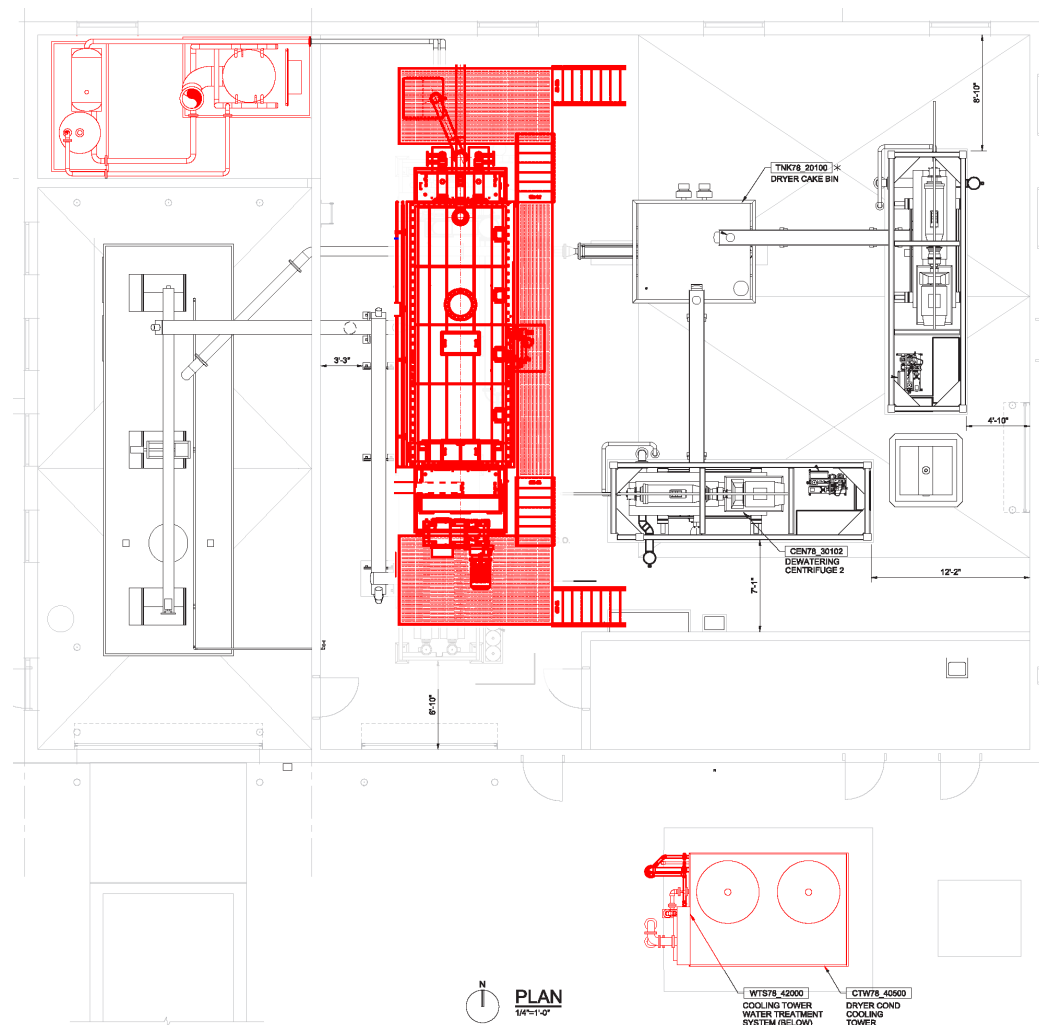

Figure 6.10 Andritz Solids Paddle Dryer Layout in Existing Dewatering and Dryer Building

Alternative 2b - Expand Existing Dewatering and Dryer Building to Accommodate a Second Solids Paddle Dryer

Expanding the existing Dewatering and Dryer Building west would allow a second solids dryer to be installed. The installation of a second solids dryer building would provide redundancy to the drying process, allowing the new unit to act as duty and the current unit to act as standby. Given the relatively small footprint, an indirect-type dryer is likely the best selection for this space, although alternative technologies could also be evaluated.

This alternative would require a retaining wall in the hillside west of the building. The existing Plant Drain Pump Station located southwest of the Dewatering and Dryer Building will also need to be modified or relocated to provide roadway access to the building expansion. However, construction and commissioning of the second solids dryer would not affect current drying operations, which may minimize interruptions to ongoing plant operations if the existing dryer is returned to service before construction of this alternative.

Figure 6.11 shows the approximate building expansion footprint to accommodate the second solids dryer.

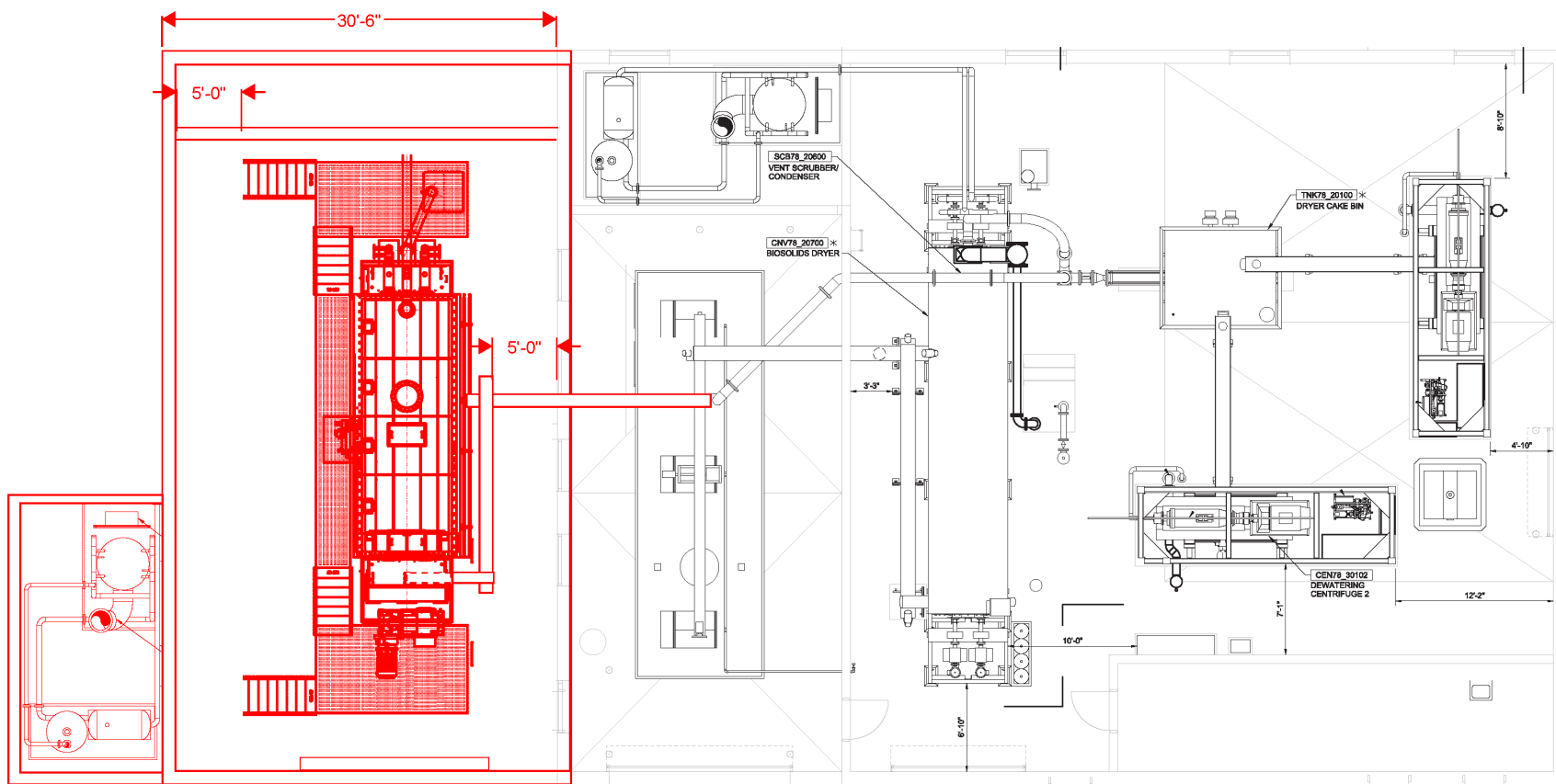

Figure 6.11 Dewatering and Dryer Building Expansion for Redundant Solids Paddle Dryer

Alternative 2c - Replace Existing Solids Paddle Dryer with a Different Solids Dryer Technology in the Existing Dewatering and Dryer Building

Other solids drying technologies have a reliable and proven solids drying track record compared to the current paddle dryer technology, such as drum or belt dryers. Both drum and belt dryers are considered “direct-type” dryers, where evaporation of water occurs by direct contact of solids with a stream of hot air.

For rotary drum dryer systems, the major components are a wet cake bin, recycle bin, mixer, furnace, drying drum, air/solids separator, screen, crusher, cooler, main fan, saturator, and storage silos, although configurations differ depending on the manufacturer. The evaporation process takes place in a horizontally mounted, slowly rotating drying drum. Dried material is conveyed through the drum where the hot air stream comes into direct contact with wet solids, evaporating the water contained in the solids.

For belt dryers, sludge is pumped or otherwise distributed onto a slowly moving horizontal belt enclosed in a housing. Solids move through one or more drying chambers where moisture is evaporated. Significant variations in belt dryer configurations exist, including the use of multiple (stacked) belts, direct or indirect heating, upward or downward airflow, and different distribution systems.

Relative benefits of the different dryer technologies are summarized below:

- Drum Dryer:
 - Produces uniform spherical pellets that can be marketed as a fertilizer. Spherical pellets produced by rotary dryers can be among the most desirable biosolids product achievable.
 - Effective at drying all types of sludges, including sticky sludge that other technologies have trouble drying.
- Belt Dryer:
 - Safest dryer technology due to relative low temperatures used.
 - Capable of using low-temperature waste heat to provide drying, if available.

For both technologies, Andritz was used as the basis for the layouts prepared in this document.

The installation of a different solids dryer system in the existing building will require a major expansion of the building as well as relocation of the existing centrifuge equipment to accommodate the larger footprints of the drum or belt dryer systems. Figure 6.12 shows the required building expansion to accommodate a drum dryer system. A drum dryer was used for this alternative because it has the largest footprint. A belt dryer system has a comparable or slightly smaller footprint. Similar to Alternative 1, it is recommended to develop a Solids Management Plan to temporarily manage dewatered cake while the existing building is being modified.

Carollo recommends additional evaluation before the final selection, design, and installation of replacement dryer equipment. A new dryer unit is expected to be a significant improvement over the current paddle dryer installation. Regardless of the final selection, however, the additional risk/operational effort associated with sludge drying will be present.

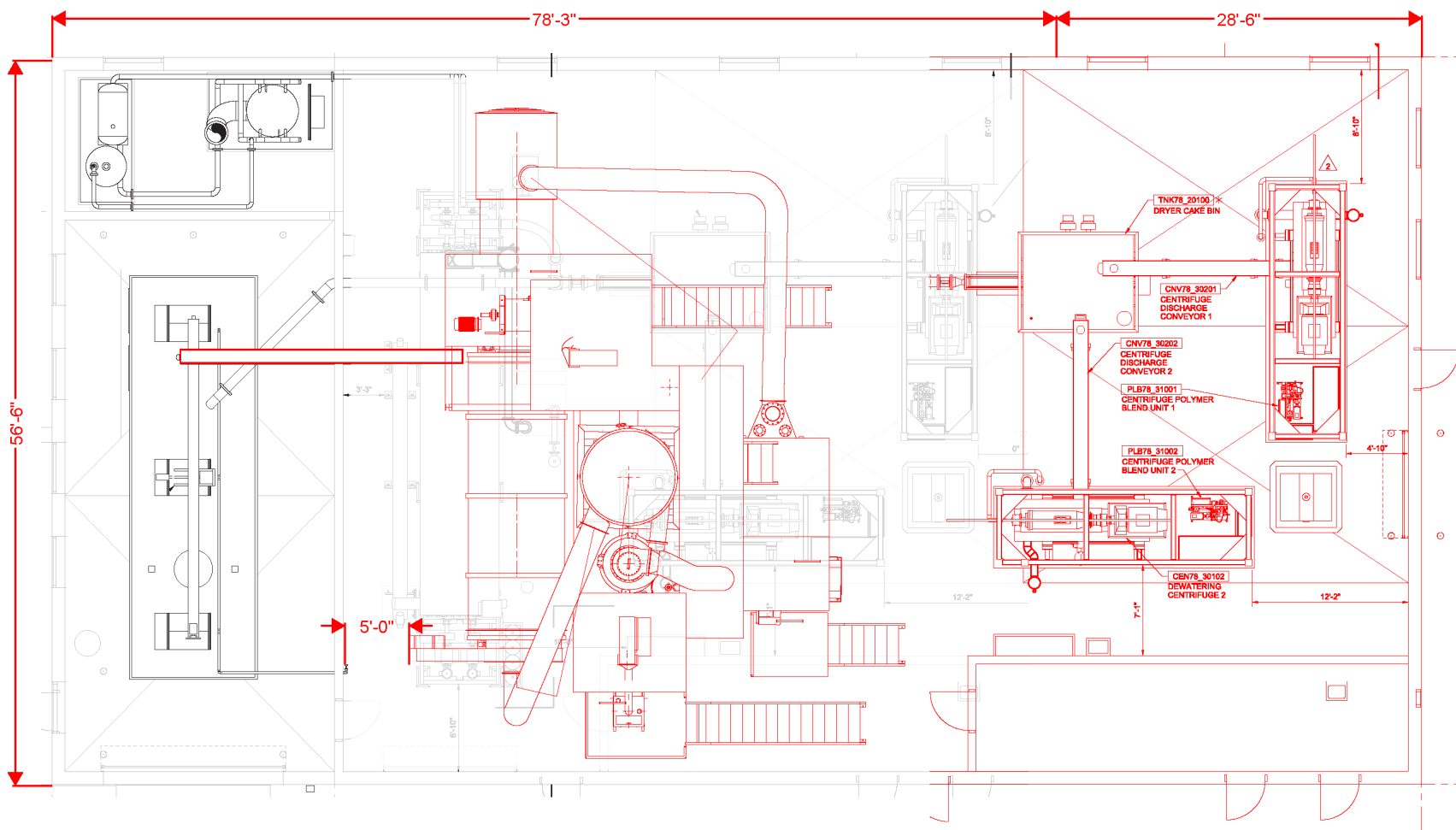

Figure 6.12 Dewatering and Dryer Building Modification for Drum Dryer System

Total Estimated Project Cost for Alternative 2

Cost estimates for all three options in Alternative 2 are shown in Table 6.6.

Table 6.6 Opinion of Probable Costs for Alternatives 2a, 2b, and 2c

Description	Class 5 Cost Estimate (2023) Accuracy Range: -50% to + 100%		
	Alternative 2a	Alternative 2b	Alternative 2c
Demolition	\$53,000	-	\$93,000
Temporary Sludge Dewatering	-	-	\$1,020,000
Civil Site Improvements	-	\$195,000	\$27,000
Process / Mechanical Improvements	\$6,097,000	\$6,625,000	\$8,269,000
Building Improvements	\$149,000	\$845,000	\$2,720,000
Electrical, Instrumentation and Control Improvements	\$218,000	\$669,000	\$603,000
Total Direct Cost	\$6,517,000	\$8,333,000	\$12,731,000
Total Estimated Construction Cost⁽¹⁾	\$10,717,000	\$13,704,000	\$20,936,000
Total Estimated Project Cost⁽²⁾	\$13,396,000	\$17,130,000	\$26,170,000

Notes:

(1) Assumes 30% Design Contingency, 10% General Conditions, and 15% Contractor Overhead and Profit.

(2) Assumes 25% Engineering, Legal, and Administrative Fees and ENR Construction Cost Index = 13473 (August 2023).

Alternative 3 - Construct New Dryer Building with a Different Solids Dryer Technology

This alternative includes constructing a new solids dryer building to accommodate a second solids dryer and truck loadout facility. Figure 6.13 provides one feasible location south of the headworks for the new building. Constructing a new solids dryer building would facilitate installation of a direct-type solids dryer like a drum or belt technology, which may provide operational and performance benefits compared to the existing technology. This alternative would also allow continued use of the existing dryer as a potential standby unit.

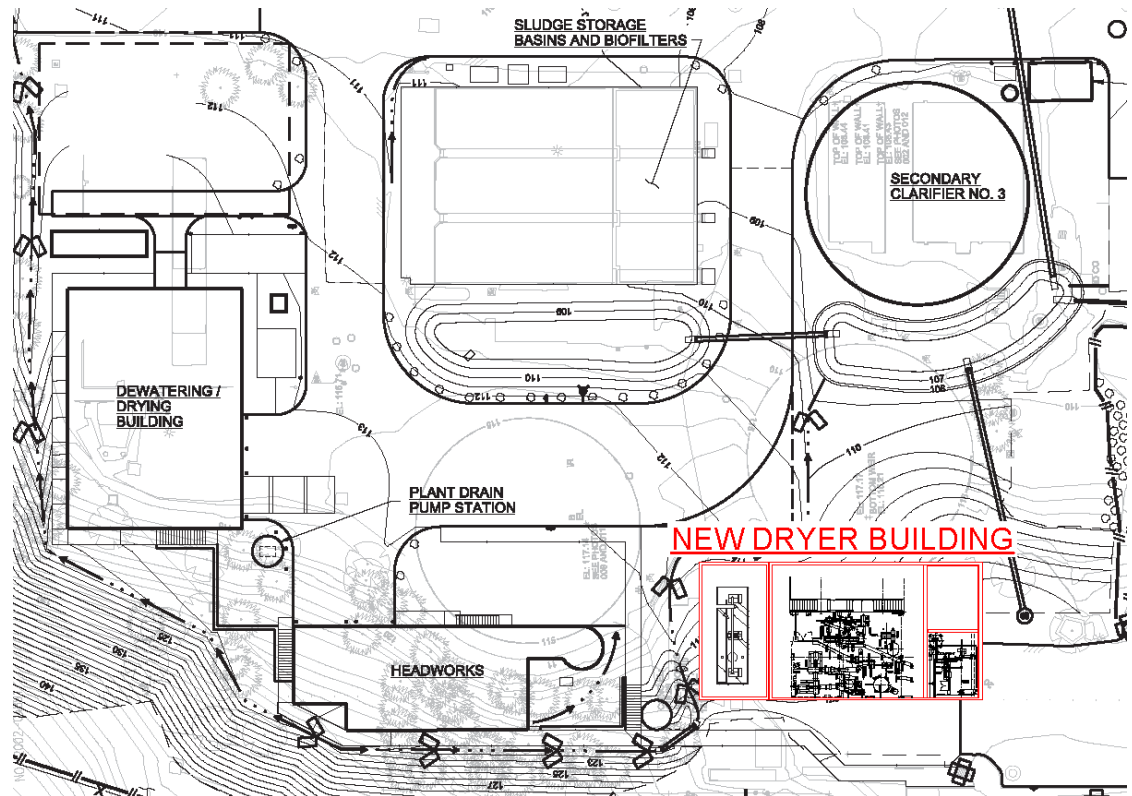

Figure 6.13 Proposed New Solids Dryer Site Plan

The following assumptions were made for this alternative's cost estimate:

- The new dryer building will be smaller than the existing Dewatering and Dryer Building because it does not need to house centrifuges. However, it will need to include a new electrical room and truck loadout facility.
- Addition of a new dryer will not require significant plant electrical infrastructure upgrades.
- Additional cake pumps will be installed in the existing Dewatering and Dryer Building to convey cake to the new dryer building.

The total project cost estimate for a new dryer building and associated cake pumps, conveyors, and truck loadout are shown in Table 6.7. Additional detail on the cost estimate is provided in Appendix J.

Table 6.7 Opinion of Probable Cost for Alternative 3

Description	Class 5 Cost Estimate (2023) Accuracy Range: -50% to + 100%
Demolition	-
Civil Site Improvements	\$398,000
Process / Mechanical Equipment	\$10,622,000
New Building	\$2,463,000
Electrical, Instrumentation, and Control Improvements	\$1,026,000
Total Direct Cost	\$14,509,000
Total Estimated Construction Cost⁽¹⁾	\$23,860,000
Total Estimated Project Cost⁽²⁾	\$29,825,000

Notes:

(1) Assumes 30% Design Contingency, 10% General Conditions, and 15% Contractor Overhead and Profit.

(2) Assumes 25% Engineering, Legal, and Administrative Fees and ENR Construction Cost Index = 13473 (August 2023).

6.5.3 Solids Drying Alternatives Comparison

As described above, recent reliability issues suggest the dryer may have a limited useful remaining service life. However, the agreement the City has with their DBO contractor, Jacobs, includes clauses (Section 8.3 - Managed Asset Valuations) describing the condition of assets which are to be met at the time of contract expiration or termination. Currently the contract is scheduled to expire September 21, 2026. The agreement includes an option to extend for an additional five years (September 2031).

It is anticipated that some useful life will remain in the existing paddle dryer and associated equipment in 2026. However, by 2031 the dryer will have been in place and operational for over fifteen years. Whether the City elects to simply replace the paddle dryer with a unit of similar size and technology or install different drying technology, it is recommended the planning and design of those upgrades begin in 2029, or sooner if operational concerns arise.

The City has indicated a preference for implementing Alternative 2b - Expand Existing Dewatering and Dryer Building to Accommodate a Second Solids Paddle Dryer. This affords some backup capacity to allow the City to continue delivering Class A solids during periods of downtime due to mechanical failure or to accommodate regular maintenance of one dryer train. Considering issues the City has experienced with the current paddle dryer, it is advised that as the anticipated time for dryer replacement approaches, they revisit the decision to plan around this technology. Advancements in technology occur regularly and equipment may be available which would alter these preliminary recommendations.

Carollo recommends the City undertake a detailed study of the secondary sludge quality, secondary process performance, chemical addition types and locations, and overall solids handling process performance prior to making a final selection of the preferred dryer alternative from the various options (1, 2a, 2b, 2c and 3) presented in this section. For purposes of capital planning, it is assumed the City will implement Alternative 2b (installing a redundant paddle dryer), with a study and confirmation of this selection beginning in 2029.

6.6 Fiber Optic Cable Addition

The City desires to establish a direct connection between the City's fiber optics network and the WWTP. This addition consists of routing two new conduits (one spare) and fiber optic cabling from the WWTP's Operations Building to the site entrance, where it will then be picked up outside of the WWTP's boundary and tied into the City's fiber optics network. Figure 6.14 provides one potential routing from the Operations Building to the site entrance that would minimize impact to existing yard utilities.

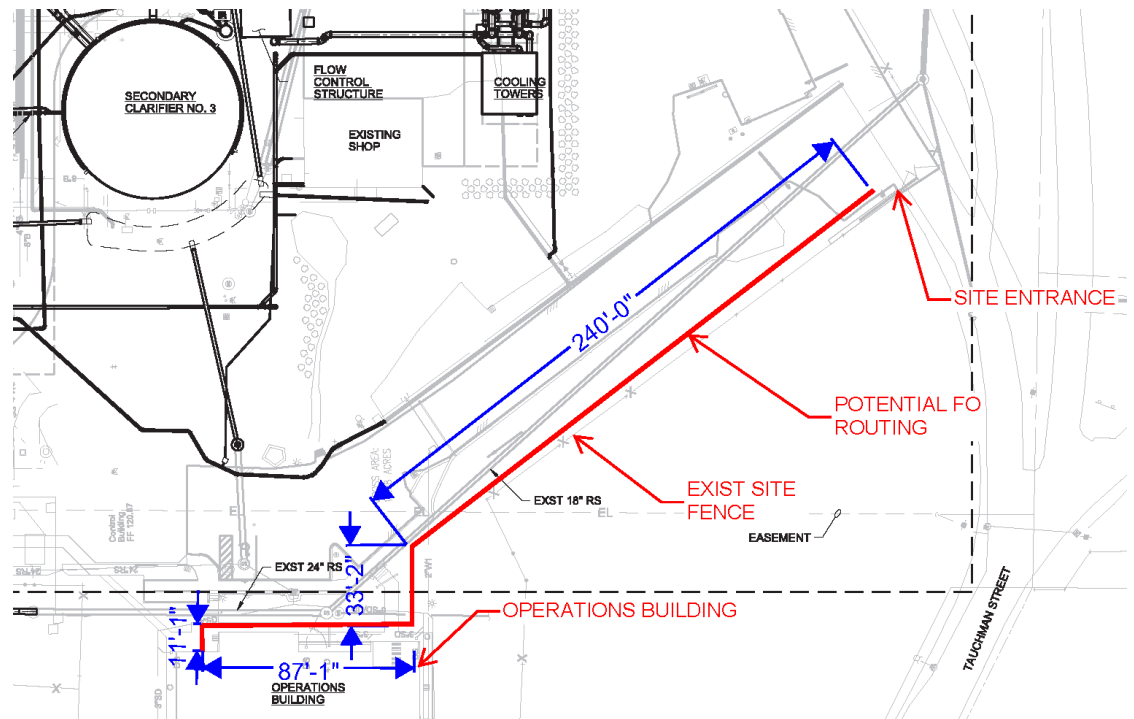

Figure 6.14 Proposed Fiber Optic Cable Addition

A cost estimate for the fiber optics conduit addition and associated costs are shown in Table 6.8. Additional detail on the cost estimate is provided in Appendix J.

Table 6.8 Fiber Optic Cable Addition Opinion of Probable Cost

Description	Class 5 Cost Estimate (2023) Accuracy Range: -50% to + 100%
Trench and Backfill	\$11,900
Two Conduits and One FO Cabling	\$15,800
Total Direct Cost	\$28,000
Total Estimated Construction Cost⁽¹⁾	\$46,000
Total Estimated Project Cost⁽²⁾	\$60,000

Notes:

- (1) Assumes 30% Design Contingency, 10% General Conditions, and 15% Contractor Overhead and Profit.
- (2) Assumes 25% Engineering, Legal, and Administrative Fees and ENR Construction Cost Index = 13473 (August 2023).

Alternatives recommended for implementation are summarized together with additional WWTP needs (rehabilitation and replacement of existing equipment) in Chapter 7.

Chapter 7

RECOMMENDED ALTERNATIVE

7.1 Introduction

This chapter outlines the recommended alternatives for improvements to the City WWTP. The capacities of the liquid and solids processes for the WWTP were assessed in Chapter 4. Detailed information about the methodology and conclusions of condition assessments and alternatives considered can be found in Chapters 2 and 6 respectively.

7.2 Summary

Table 7.1 summarizes the upgrades required through the planning period. As shown in Table 7.1, within the planning period (through 2045) increased capacity will be needed in the secondary treatment process, specifically additional process volume in the form of a new aeration basin as well as aeration blower capacity and intensification utilizing membrane bioreactor technology. Within the next five years, Secondary Clarifiers Number (No.) 1 and No. 2 will require new mechanisms. Table 7.1 also identifies replacement of aging equipment or equipment that has not been performing as desired.

Table 7.1 Recommended Plan Through the Year 2045

Unit Process	Upgrade	Year Upgrade Required	Trigger
Aeration Basins and Blowers	New Aeration Basin and Blower	2027	Capacity
Secondary Clarifiers	New Mechanisms	2027	Condition
Secondary Treatment	New MBR and Support Facilities	2031, 2039, 2044	Capacity
Disinfection	Replace Standby UV Equipment Replace UV System Equipment	2025, 2040	Condition
Outfall	Outfall Improvements	2040	Capacity
Effluent Cooling Tower	New Cooling Tower	2036	Capacity
WAS Thickening/Storage, TWAS Storage, Dewatering Centrifuges	Dewatering Performance Optimization	2025	Condition
Dewatering and Thickening ⁽¹⁾	Replace Centrifuge and GBT Equipment	2033	Condition
Biosolids Drying ⁽²⁾	Replace Dryer Equipment	2031	Condition
Communication/IT	Fiber Optic Cable Addition	2025	Condition
Support Buildings	Seismic Improvements	2026	Condition
Support Buildings	Geotechnical Foundation Mitigation	2026	Condition

Notes:

- (1) The centrifuges installed with the City's 2014 upgrade project have exhibited inconsistent performance in recent months. The City recently refurbished these units and expects they will provide sufficient capacity through 2042. However, by that time, the units will have been in service for over 30 years. It is recommended the City plan for replacement of these units during the planning horizon of this Master Plan. Assuming replacement occurs in the mid-2030's the City should reassess capacity needs of those units beyond the 2045 horizon, consistent with the expected service life of the new equipment.
- (2) Analysis has concluded that the existing solids dryer equipment has sufficient capacity through 2045. As with the dewatering centrifuges, the dryer equipment will soon have been in operation for a decade and is approaching the end of its useful life. It is recommended the City plan for replacement of the dryer during the planning horizon of this Master Plan.

Abbreviations: CIP - capital improvement plan.

Chapter 4 presents a summary of detailed capacity analyses conducted for this Master Plan. The years in which key processes are projected to exceed capacity are presented in Figure 7.1. The green line illustrates projected MM BOD triggers for existing and proposed new secondary treatment facilities. Projected PHF is shown in blue indicating capacity exceedance of the cooling tower and certain elements of plant hydraulics. Prior to the year of projected exceedance, planning, design, and construction activities will be required to allow upgrades to be commissioned to prevent capacity exceedances. It is important to note that the timing of improvements should be driven by the rate of growth in influent flow and load. Dates indicated in Figure 7.1 and elsewhere in this document should be considered best, conservative estimates based on projections presented herein and professional judgement.

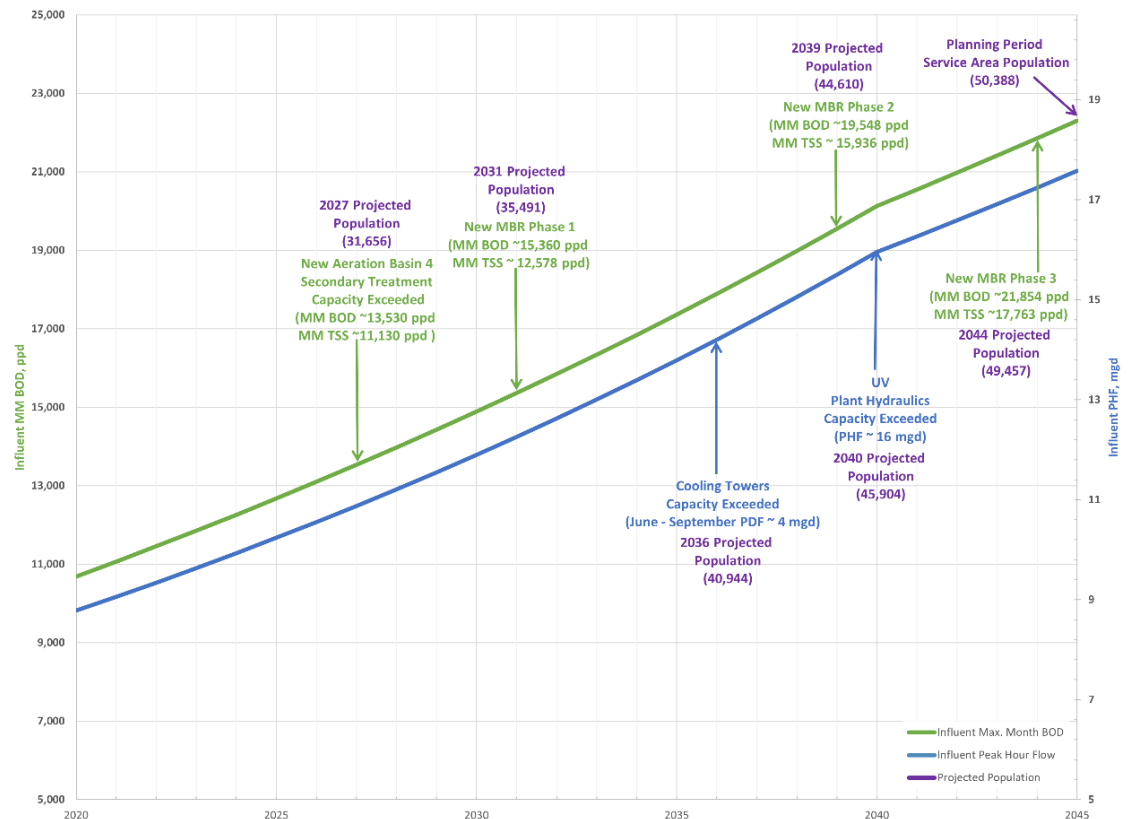

Figure 7.1 Capacity Trigger Graph

7.3 Recommended Improvements

The WWTP improvement recommendations are based on the evaluation and conclusions previously described in Chapter 2 - Condition Assessment and Tier 1 Seismic Analysis Summary, Chapter 4 - Capacity Analysis, and Chapter 6 - Alternative Development and Evaluation. The seismic improvements are also described in Chapter 2, and Appendix D includes Carollo's complete seismic evaluation report.

7.3.1 Liquid Treatment System Improvements

The recommended capacity and condition improvements for the major liquid stream unit processes through 2045 are summarized below:

- **New Aeration Basin:** In the next few years, the MLSS concentration in the aeration basins is projected to exceed 4,000 mg/L, which will require the addition of secondary treatment capacity. An additional aeration basin would increase capacity by providing more volume, which would result in a lower overall MLSS concentration and lower solids loading rates on the secondary clarifiers. The City should begin re-evaluating capacity and planning for expansion when the max month influent biochemical oxygen demand (BOD) reaches approximately 13,500 ppd, which is estimated to occur in 2027. Additional aeration blower capacity will be required to provide sufficient air when a new basin is added. The recommended plan includes addition of a seventh blower and conversion of one of the existing blowers. The new and converted blowers would have a capacity of 3,000 scfm each.
- **New MBR and Support Facilities:** To provide the projected secondary treatment capacity required in 2045, a fourth aeration basin will not be sufficient. In fact, as described in greater detail in Chapters 4 and 6, the City will need to intensify the secondary treatment process. The process selected for this intensification is MBR technology which the City intends to phase in over time as capacity demands dictate. Eventually membrane treatment will eliminate the need for secondary clarification and tertiary filtration altogether. Phasing the MBR improvements over the planning period anticipates reliance on clarifiers and tertiary filters for some time. In addition to the core membrane facility, which will involve construction of a new building and five membrane reactor basins, the City will need to install fine screens to protect the membrane units themselves and additional blower capacity to provide sufficient aeration through 2045. The first phase of the MBR upgrade is anticipated to be in place around 2031, with the third phase of the upgrade for this planning period (through 2045) needed some time around 2044. The phased approach to intensification with MBR technology positions the City to address needs beyond projected 2045 loading, or if limitations on effluent discharges to the Willamette River become more stringent. Plans for the MBR infrastructure buildings and support facilities anticipate these potential needs to minimize significant site work or building/structure construction at that time.
- **New Secondary Clarifier Mechanisms:** From April 19 to April 21, 2022, Ovivo completed a field service report of the plant's secondary clarifiers No. 1 and No. 2. While both units were in operating condition, a couple repairs are needed. The recommended repairs include drive controls for both units, new skimmers for both units, squeegees for both tanks rake arms, energy dissipating inlet chains, one motor and reducer assembly, and one skimmer arm assembly. The detailed Ovivo Field Service Report is included in Appendix C. In addition to requiring repairs, both secondary clarifiers have been in service for 25 years, so new secondary clarifier mechanisms are recommended due to age.
- **Trojan UV 4000 System:** While only used as a backup to the existing Suez UV system, the Trojan system's human-machine interface (HMI) has errors that prevent it from showing the status of the lamps in module 3, and its overall condition is mostly unknown. Additionally, this backup UV system predates the WWTP's 2014 Upgrade, so

the system is no longer supported. The City's contract operations team (Jacobs) have concluded that replacement of this system is recommended and are currently pursuing this course of action. When this replacement occurs, the capacity of the backup UV unit is expected to increase. Regardless the capacity of the UV process is predicted to be exceeded after 2040. By that time, both existing (newer) Suez UV equipment and the replacement unit(s) for the backup Trojan system will have exceeded, or be approaching their expected service life. Although Jacobs is initiating the initial backup system replacement, it is still included in the recommended WWTP CIP for budgeting purposes. Since the replacement of the Trojan 4000 UV system backup equipment is driven by condition needs, costs were not previously presented in Chapter 6 of this Master Plan and are provided in Appendix K.

- Outfall/Plant Hydraulics:** The Jacobs *Hydraulic Analysis TM* (Appendix H) found that under projected 2045 PHF conditions certain process and effluent piping may be hydraulically deficient. At PHF 17.6 mgd and assuming a 0.8 mgd recycle scenario the headworks screens and grit removal systems are expected to be unsubmerged. However, upsized piping is expected to be necessary to convey flow from the headworks to the secondary process under these conditions. These hydraulic deficiencies are expected to be addressed with the phased MBR upgrades described elsewhere. The 24-inch piping between MH-B (downstream of the UV disinfection process) and the 42-inch pipeline downstream of MH-D2, but upstream of the Willamette River outfall/diffuser, is a hydraulic restriction under the PHF 17.6 mgd and 0.8 mgd recycle scenario. This outfall piping improvement is included in the recommended WWTP CIP by the year 2040, once plant hydraulics exceed a PHF of 16 mgd. There are several options that could relieve the restriction and are further discussed in the Jacobs analysis found in Appendix H.
- New Cooling Tower Unit:** The existing effluent cooling system is expected to run out of firm capacity by 2036. However, prior planning anticipated this need and space for an additional cooling tower unit (with similar size and design parameters as the existing units) exists on-site and can be added to ensure there is sufficient capacity to cool effluent through the end of the planning period. There is adequate space to insert a third unit including a flanged connection installed in anticipation of this need.

The recommended liquid stream improvements will provide additional capacity. Addition of MBR facilities and equipment will significantly alter the liquid stream biological treatment process configuration. Figure 7.1 illustrates this future configuration in a simplified process flow diagram. More detailed process flow schematics of current WWTP processes are provided in Appendix G.

7.3.2 Solids Treatment System Improvements

The recommended improvements for the major solids stream unit processes through 2045 are summarized below:

- Dewatering and Thickening:** As detailed in Chapter 6, the dewatering system has sufficient capacity through the year 2042 with one unit out of service. By the year 2042 though, the existing centrifuge and GBT units will have been in service for at least 30 years. Therefore, the City should plan for their replacement before 2045 with the new units sized for updated projected solids loading. Timing of the dewatering equipment replacement will depend upon performance and wear of the existing units. For

budgeting purposes, an opinion of probable cost for replacing the existing centrifuges is provided in Appendix K and included in the WWTP CIP. Current CIP costs assume a slightly larger unit to account for the potential for updated solids loading projections to exceed the capacity of the existing units over the life of the replacement units. Larger units also provide enhanced flexibility to effectively dewater more difficult sludges, reduce operational periods, and provide increased resiliency to plant upsets.

- **Solids Dryer Improvement:** As discussed in Chapter 6, the existing solids dryer capacity appears sufficient through 2045. However, in recent years the equipment has not functioned reliably. Due to the history of operational issues and failures, as well as the fact the unit will have been in operation for over 30 years by 2045, the City has chosen to plan for the replacement of the dryer unit during the planning horizon of this Master Plan. Several alternatives to replace the existing paddle dryer unit were considered and presented in Chapter 6. For the purposes of capital planning, this Master Plan assumes the City will expand the existing Dewatering and Dryer Building to the west to allow installation of a second solids paddle dryer, with the existing dryer remaining available as a redundant unit after refurbishment. The City plans to evaluate the preferred dryer replacement approach beginning in 2031. This future study will likely assess the suitability of an indirect-type dryer given the space constraints. The City will adjust budgetary projections for the dryer replacement as appropriate based on the results of this future study.

A process flow diagram illustrating the solids treatment process is shown in Figure 7.2.

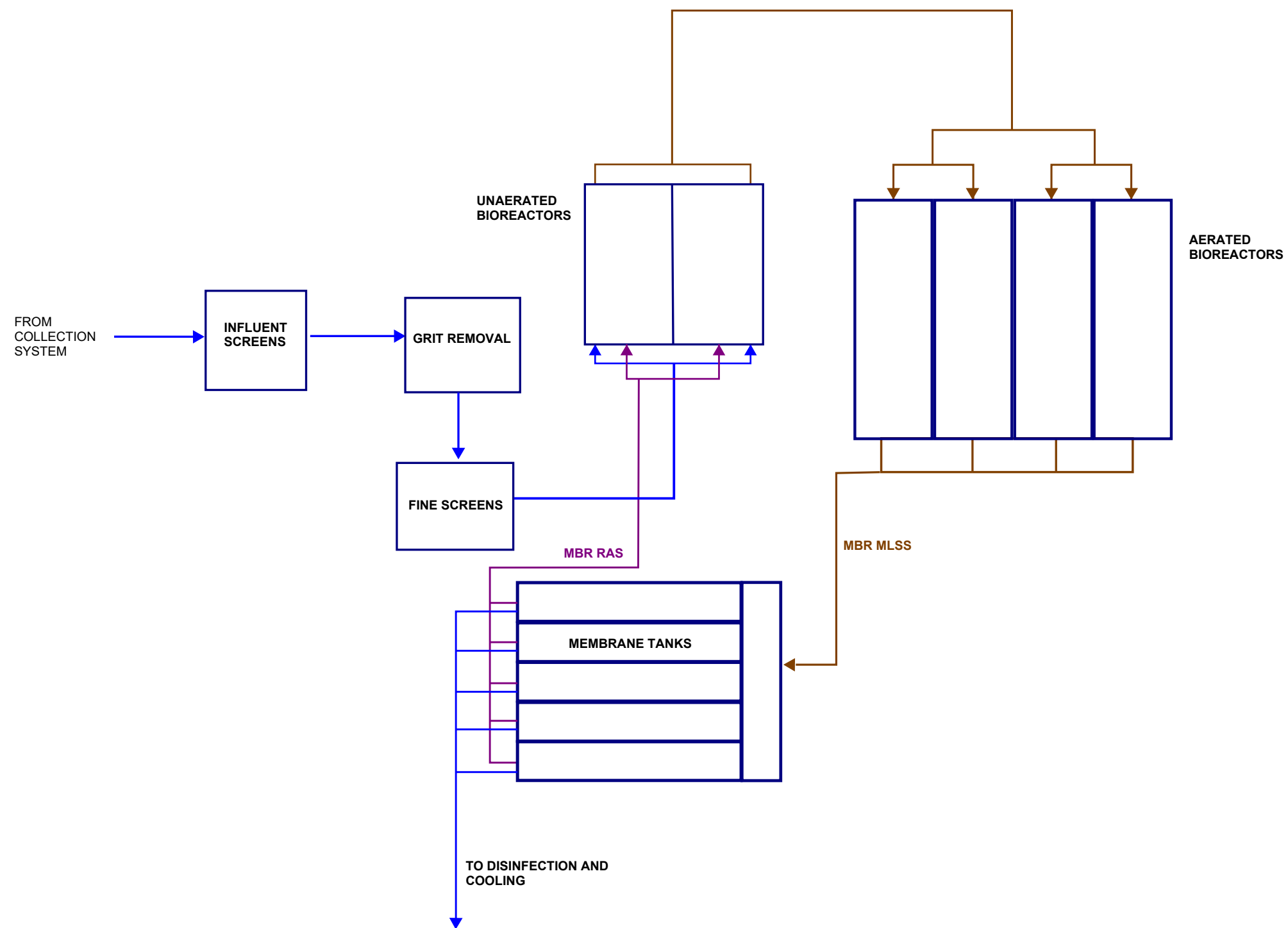

NOTE: Liquid stream biological treatment process under future conditions. Operational split between CAS and MBR processes to remain in place until completion of Phase 3 MBR upgrades, expected by 2044.

Figure 7.2
SIMPLIFIED LIQUID STREAM PROCESS FLOW DIAGRAM
 CITY OF WILSONVILLE

Plot Date: 6/3/2022 1:08:07 PM

FILE NAME: 11962A00_FIGURE_SEED.DWG

LAST SAVED BY: bhaves

7.3.3 Seismic and Geologic Hazard Recommendations

Prior to the seismic evaluation discussed in Chapter 2, Carollo's subconsultant, Northwest Geotech Inc. (NGI), conducted a geologic hazard assessment of the City's WWTP. The assessment determined that the WWTP's primary site hazard is the differential settlement that may be caused by soil piping. In 2023, NGI conducted a survey to map existing cracks in structures and identified previous sinkholes and settlement repairs to help prioritize areas for soil piping risk reduction. The City intends to evaluate the need and extent of ground improvement for WWTP structures during preliminary design of seismic upgrades identified in Chapter 2. Accordingly, an allowance for future foundation mitigation measures of \$2 million is included in the City's CIP. The City will also consider ground improvement on future projects involving new or existing structures, as appropriate. NGI's complete technical memoranda can be found in Appendices E and F, with more details regarding the geologic hazard assessment and survey outlined in Chapter 2.

In 2021 Carollo performed a seismic evaluation and analysis of the City's WWTP, as detailed in Chapter 2. First, a Tier 1 (Screening) seismic evaluation was completed to identify potential deficiencies and needs for additional analysis, which identified five older structures for further investigation. This plant was upgraded in 2014, so much of the infrastructure was designed in accordance with the 2010 Oregon Structural Specialty Code (OSSC) and follows modern seismic design and detailing. The Tier 2 (deficiency-based evaluation and retrofit) seismic evaluation included the five structures identified during the Tier 1 evaluation, which are the:

- Operations building.
- Process gallery.
- Workshop.
- Aeration basins and stabilization basins.
- Sludge storage basins and biofilter.

Table 7.2 below summarizes the number of seismic deficiencies identified for each structure and provides a cost estimate for each structure. No deficiencies were found for the aeration basins and biofilter structures. The only potential deficiency identified for the stabilization and sludge storage basins was a potential freeboard deficit, which is detailed further in Chapter 2 and Appendix D.

Table 7.2 Summary of Estimated Retrofit Opinion of Probable Cost

Structure	No. of Deficiencies Identified	Class 5 Cost Estimate (2023) Accuracy Range: -50% to + 100%
Operations Building	7	\$688,200
Process Gallery	3	\$48,100
Workshop	4	\$122,700
Overall Plant (Non-Structural)	3	\$6,100
Total Estimated Construction Cost		\$865,100
Total Estimated Project Cost⁽¹⁾		\$1,082,000

Notes:

(1) Assumes 25% Engineering, Legal, and Administrative Fees (ELA) and ENR Construction Cost Index = 13473 (August 2023).

7.3.4 Fiber Optic Cable Addition

The City would like to install a direct connection between the City's fiber optics network and the WWTP. As presented in Chapter 6, this addition consists of routing two new conduits (one spare) and fiber optic cabling from the WWTP's Operations Building to the Site Entrance, where it will then be picked up outside of the WWTP's boundary and tied into the City's fiber optics network. The estimated cost for this addition is included in Chapter 6 and the WWTP CIP.

7.4 Site Plan

Detailed site plan layouts are presented for improvement alternatives considered in Chapter 6. A site plan depicting the collective recommended improvements is presented here in Figure 7.3.

7.5 Planning Level Opinion of Probable Cost and Phasing

Summaries of opinions of probable costs and anticipated phasing for the recommended improvements are provided in Table 7.3. Estimates of each of the projects presented within the table with component element breakdown, including contingency and soft costs, are presented elsewhere in this Master Plan. Contingency factors included in cost opinions are considered reasonable for the facility planning stage to account for "known" elements of project scope. This allowance does not anticipate potential project specific risks, such as market conditions at time of implementation, unknown construction conditions (rock, groundwater etc.) that may be revealed during design (detailed field investigations) or construction, or change orders which may arise as a result.

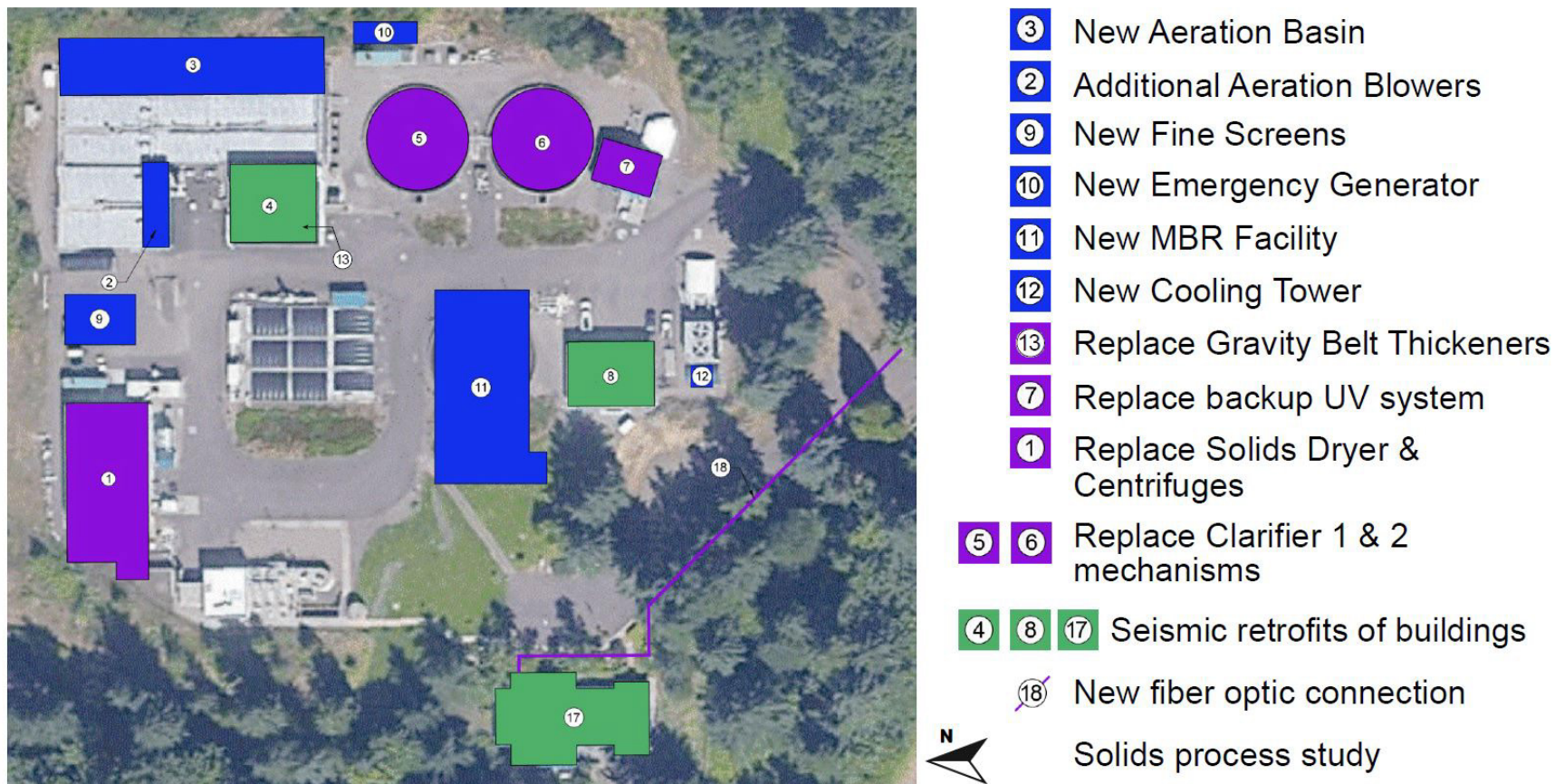

Figure 7.3 Proposed WWTP Improvements Site Plan

Table 7.3 WWTP Recommended Alternative Opinion of Probable Cost and Phasing

Plant Area	Project ⁽¹⁾	Opinion of Probable Cost ⁽²⁾	Approximate Year Online
Solids Handling	Dewatering Performance Optimization	\$150,000	2025
Communications/IT	Fiber Optic Cable Addition	\$60,000	2025
UV System	Backup UV System Improvement	\$1,705,000	2026
Support Buildings	Seismic Improvements	\$1,082,000	2026
Support Buildings	Geotechnical Foundation Mitigation	\$2,000,000	2026
Secondary Treatment	New Conventional Aeration Basin and Blower	\$10,222,000	2027 ⁽³⁾
Secondary Treatment	New Secondary Clarifier Mechanisms	\$1,775,000	2027
Secondary Treatment	New MBR, Blowers and Fine Screens (Phase 1)	\$69,727,000	2031
Solids Handling	Solids Dryer Improvement	\$17,130,000 ⁽⁷⁾	2033
Solids Handling	Existing Centrifuge and GBT Replacement	\$3,701,000 ^(4,6)	2033 ⁽⁵⁾
Cooling Towers	New Effluent Cooling Tower	\$642,000	2036
Secondary Treatment	Additional MBR and Blower Capacity (Phase 2)	\$2,330,000	2039
UV System	UV Equipment Replacement	\$2,571,000	2040
Outfall	Outfall Improvements	\$1,244,000	2040
Secondary Treatment	Additional MBR and Blower Capacity (Phase 3)	\$8,117,000	2044
TOTAL		\$122,456,000	

Notes:

White rows indicate projects that are in the City's 5-year CIP and blue rows indicate projects that are outside the 5-year CIP window.

- (1) Details of each project can be found in Chapter 2 or Chapter 6 of this Master Plan.
- (2) The estimated opinion of probable costs include the construction costs plus ELA (or soft costs). Details on the estimated project costs can be found in Chapter 2 or Chapter 6 of the plan, with the exception of costs for the backup UV system and centrifuges which are presented earlier in Chapter 7. All costs presented are based on an August 2023 ENR index of 13473.
- (3) As identified in Chapter 4, the secondary treatment process at the Wilsonville WWTP is expected to require additional capacity by the year 2027. Since design and construction of a new aeration basin may take longer than the year 2027, the City will likely need to operate at SRTs lower than 5 days during the maximum week condition if growth occurs as predicted in Chapter 3.
- (4) For budgeting purposes, the Option B centrifuge cost from Table H-2 in Appendix K is used for the project cost summary and the CIP.
- (5) Replacement timing dependent upon satisfactory equipment performance.
- (6) The centrifuges installed with the City's 2014 upgrade project have exhibited inconsistent performance in recent months. The City recently refurbished these units and expects they will provide sufficient capacity through 2042. However, by that time, the units will have been in service for over 30 years. It is recommended the City plan for replacement of these units during the planning horizon of this Master Plan. Assuming replacement occurs in the mid-2030's the City should reassess capacity needs of those units beyond the 2045 horizon, consistent with the expected service life of the new equipment.
- (7) The existing solids dryer has sufficient capacity through 2045. As with the dewatering centrifuges, the dryer equipment will soon have been in operation for a decade. It is recommended the City plan for replacement of the dryer during the planning horizon of this Master Plan. The City plans to replace the existing dryer with a new piece of equipment using similar technology and potentially rehabilitate the existing unit to serve as a backup. See Alternative 2B, Chapter 6.

7.6 Project Schedule and Phasing

Figure 7.4 presents a summary of the recommended project phasing for the 20-year CIP. The necessary planning and design phases of work for each project would need to precede the listed dates to allow for these improvements to be operational by the listed date.

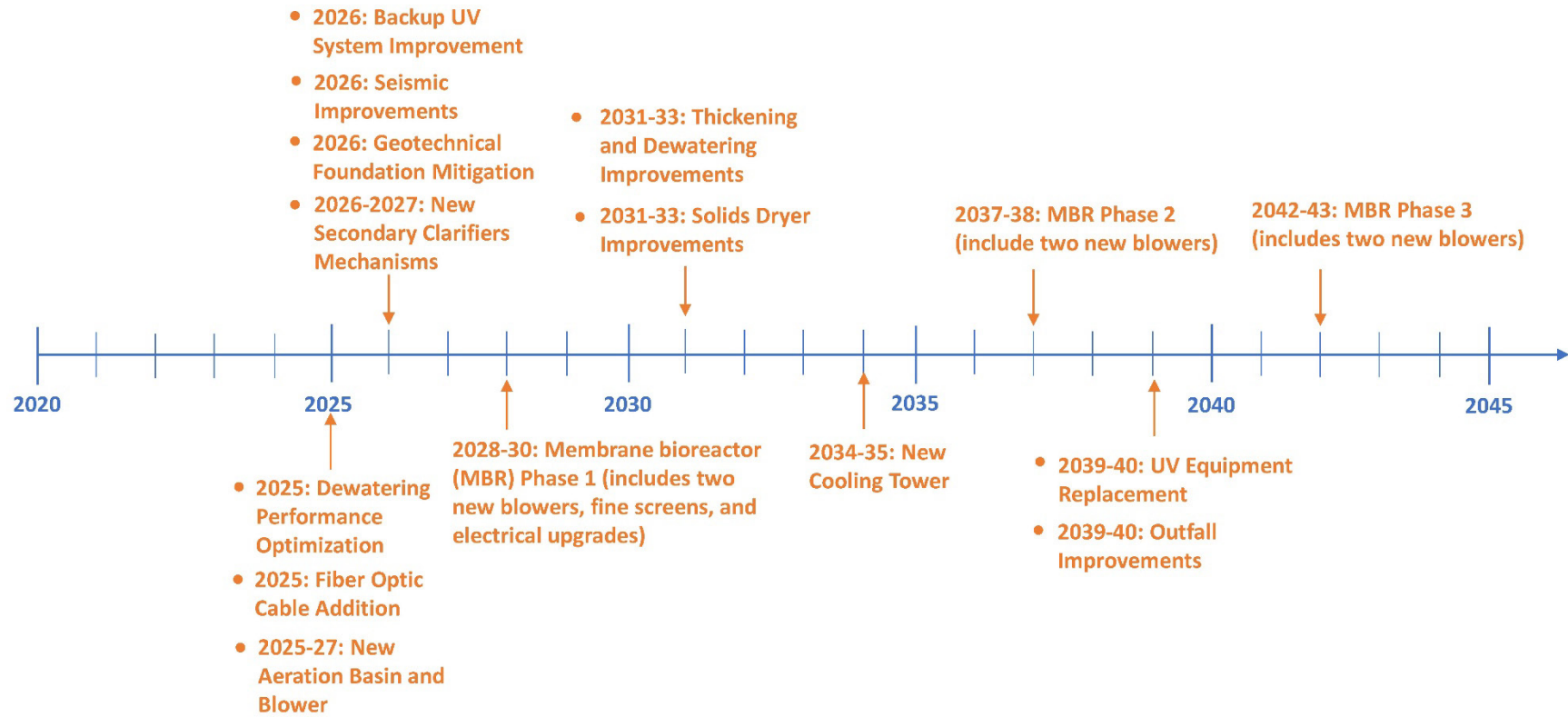

Figure 7.4 Recommended Project Phasing Schedule

7.7 Financial Analysis – Capital Improvement Plan

The expected cash flow for the planning period was determined for the recommended improvements summarized in Table 7.4. The cash flow through 2045 is summarized in Table 7.4, which includes an escalation rate of three percent. The peak expenditure is approximately \$55,434,000 in 2030. The projected CIP expenditures through 2045 are also visually shown in Figure 7.5.

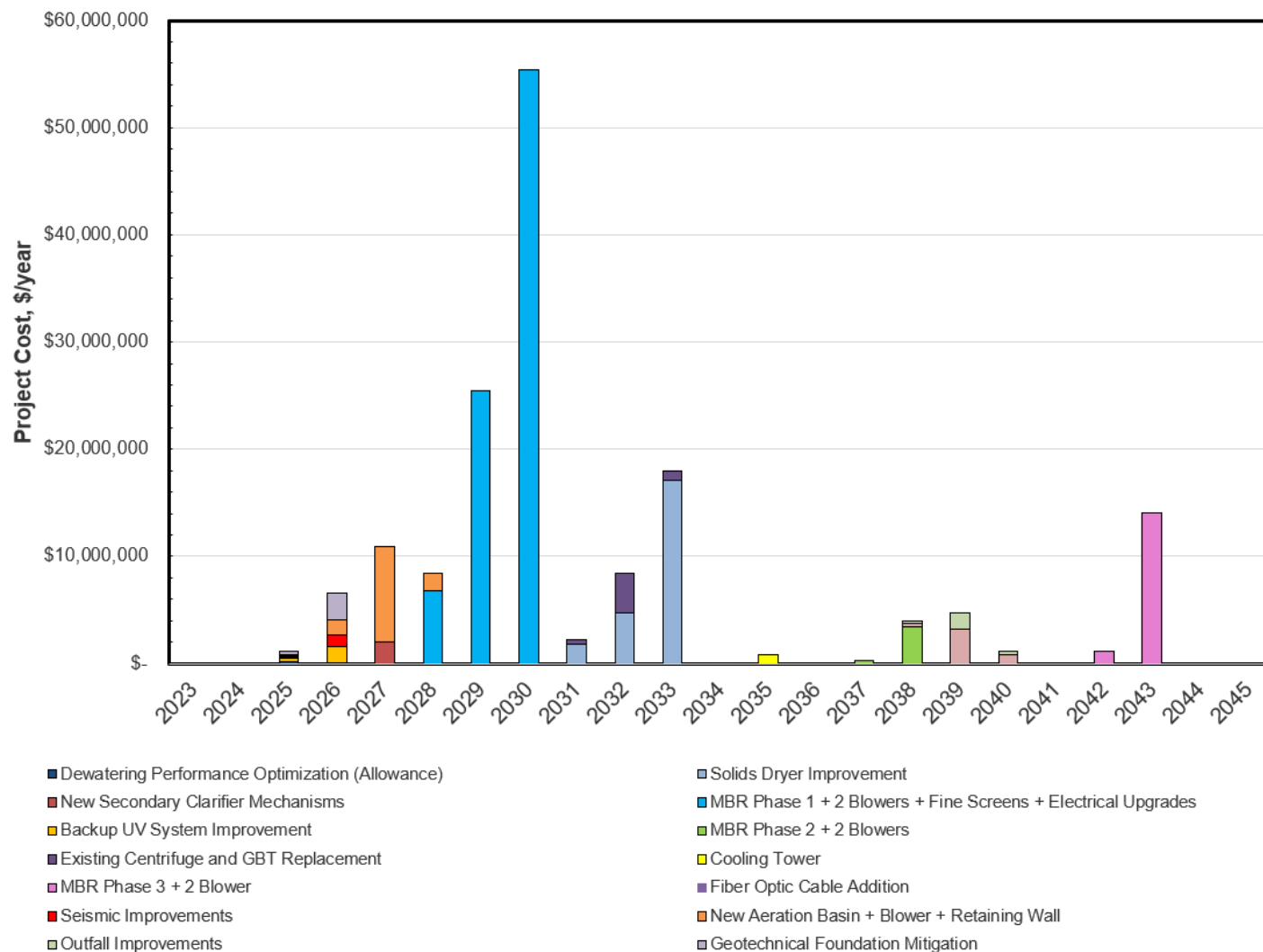

Figure 7.5 Projected 20-Year CIP Expenditures

Table 7.4 Cash Flow Summary⁽¹⁾⁽²⁾

By Project	2025	2026	2027	2028	2029	2030	2031	2032	2033	2034	2035	2037	2038	2039	2040	2042	2043	2044-2045	Project Total
Dewatering Performance Optimization	\$167,000	-	-	-	-	-	-	-	-	-	-	-	-	-	-	-	-	-	\$167,000
Backup UV System Improvement	\$363,000	\$1,565,000	-	-	-	-	-	-	-	-	-	-	-	-	-	-	-	-	\$1,928,000
Fiber Optic Cable Addition	\$63,000	-	-	-	-	-	-	-	-	-	-	-	-	-	-	-	-	-	\$63,000
Seismic Improvements	\$131,000	\$1,094,000	-	-	-	-	-	-	-	-	-	-	-	-	-	-	-	-	\$1,225,000
Geotechnical Foundation Mitigation	\$302,000	\$2,527,000	-	-	-	-	-	-	-	-	-	-	-	-	-	-	-	-	\$2,829,000
New Aeration Basin + Blower + Retaining Wall	\$115,000	\$1,356,000	\$8,819,000	\$1,613,000	-	-	-	-	-	-	-	-	-	-	-	-	-	-	\$11,903,000
New Secondary Clarifier Mechanisms	-	\$21,000	\$2,067,000	-	-	-	-	-	-	-	-	-	-	-	-	-	-	-	\$2,088,000
MBR Phase 1 + 2 Blowers + Fine Screens + Electrical Upgrades	-	-	-	\$6,767,000	\$25,449,000	\$55,434,000	-	-	-	-	-	-	-	-	-	-	-	-	\$87,650,000
Solids Dryer Improvement	-	-	-	-	-	-	\$1,812,000	\$4,716,000	\$17,050,000	-	-	-	-	-	-	-	-	-	\$23,578,000
Existing Centrifuge and GBT Replacement	-	-	-	-	-	-	\$393,000	\$3,746,000	\$912,000	-	-	-	-	-	-	-	-	-	\$5,051,000
Cooling Tower	-	-	-	-	-	-	-	-	-	\$101,000	\$846,000	-	-	-	-	-	-	-	\$947,000
MBR Phase 2 + 2 Blowers	-	-	-	-	-	-	-	-	-	-	-	\$297,000	\$3,468,000	-	-	-	-	-	\$3,765,000
UV Equipment Replacement	-	-	-	-	-	-	-	-	-	-	-	-	\$337,000	\$3,193,000	\$777,000	-	-	-	\$4,307,000
Outfall Improvements	-	-	-	-	-	-	-	-	-	-	-	-	\$163,000	\$1,546,000	\$376,000	-	-	-	\$2,085,000
MBR Phase 3 + 2 Blower	-	-	-	-	-	-	-	-	-	-	-	-	-	-	-	\$1,197,000	\$14,009,000	-	\$15,206,000
Total	\$1,141,000	\$6,563,000	\$10,886,000	\$8,380,000	\$25,449,000	\$55,434,000	\$2,205,000	\$8,462,000	\$17,962,000	\$101,000	\$846,000	\$297,000	\$3,968,000	\$4,739,000	\$1,153,000	\$1,197,000	\$14,009,000	-	\$162,972,000

Notes:

- (1) Costs in this table reflect application of a 3% per year escalation over the planning period. Costs elsewhere in this Chapter are indexed to August 2023.
- (2) No expected cash flow in the years of 2036, and 2041. (Not shown in table).

Appendix A

JACOBS CONDITION ASSESSMENT 2019

Appendix B
BROWN AND CALDWELL CONDITION
ASSESSMENT 2019

Appendix C

OVIVO FIELD SERVICE REPORT

Appendix D

SEISMIC EVALUATION

Appendix E
SEISMIC RESPONSE AND GEOLOGIC HAZARDS
ASSESSMENT

Appendix F

GEOTECHNICAL ASSESSMENT TM 2023

Appendix G

WASTEWATER TREATMENT PLANT SCHEMATICS

Appendix H

JACOBS HYDRAULIC ANALYSIS TM 2023

Appendix I

PENNY CAROLO CONSIDERATIONS FOR NEXT PRETREATMENT LOCAL LIMITS EVALUATION

Appendix J

CLASS 5 COST ESTIMATES

Appendix K

BACKUP UV REPLACEMENT AND DEWATERING EQUIPMENT REPLACEMENT COST ESTIMATES

The Wastewater Treatment Plant Master Plan (LP22-0001) Appendices can be found at this link:

<https://www.ci.wilsonville.or.us/comm-dev/page/wastewater-treatment-plant-master-plan>

CONCLUSIONARY FINDINGS

The updated Wastewater Treatment Plant Master Plan has been found to be consistent with the applicable criteria as follows.

COMPREHENSIVE PLAN COMPLIANCE

Standards for Approval of Plan Amendments

In order to grant a Plan amendment, the City Council shall after considering the recommendation of the Development Review Board (quasi-judicial) or Planning Commission (legislative), find that:

a. Conformance with Other Portions of the Comprehensive Plan

CP1. **Review Criteria:** “The proposed amendment is in conformance with those portions of the Plan that are not being considered for amendment.”

Finding: These criteria are satisfied.

Explanation of Finding: The proposed updated Wastewater Treatment Plant Master Plan has been found to be in conformance with the Comprehensive Plan. See Findings CP2 through CP30 below.

b. Amendment is in the Public Interest

CP2. **Review Criterion:** “The granting of the amendment is in the public interest.”

Finding: This criterion is satisfied.

Explanation of Finding: Development Code Subsection 4.198 (.01) A. implements this standard. It is in the public interest to periodically update the master plans for critical public facilities such as the wastewater treatment plant to ensure the system provides for adequate service for current and future residents and businesses to ensure proper treatment of wastewater.

c. Public Interest and Timing of Amendment

CP3. **Review Criterion:** “The public interest is best served by granting the amendment at this time.”

Finding: This criterion is satisfied.

Explanation of Finding: Facility master plans such as the wastewater treatment plant must be updated periodically to provide updated current condition information and use updated data to forecast future needs. The last update to the Wastewater Treatment Plant Master Plan was in 2004, so the public interest is best served by updating the master plan as soon as possible making the current timing appropriate.

d. Adequately Addressing Specific Factors

CP4. **Review Criteria:** “The following factors have been adequately addressed in the proposed amendment: the suitability of the various areas for particular land uses and improvements; the land uses and improvements in the area; trends in land improvement; density of development; property values; the needs of economic enterprises in the future development of the area; transportation access; natural resources; and the public need for healthful, safe and aesthetic surroundings and conditions.”

Finding: These criteria are satisfied.

Explanation of Finding:

Suitability of the Various Areas for Particular Land Uses and Improvements: The plan only considers serving areas otherwise acknowledged as future growth areas. The plan includes analysis of the current location and how to best expand within the limited footprint.

Land Uses and Improvements in the Area: The updated Wastewater Treatment Plant Master Plan considers the current land uses throughout the city as well as potential land uses in future growth areas.

Trends in Land Improvement: The amended Wastewater Treatment Plant Master Plan supports the trends identified in other master plans and studies.

Density of Development: The updated Wastewater Treatment Plant Master Plan considers planned densities throughout the City and growth areas over the planning horizon.

Property Values: Planning for an adequate wastewater treatment plant helps enable a functional system long term which supports sanitation. Lack of proper sanitation and ability to properly dispose of wastewater would negatively affect property values.

The Needs of Economic Enterprises in the Future Development of the Area: Planning for an adequate wastewater treatment plant helps support economic enterprise in areas planned for business growth by planning adequate capacity and service.

Transportation Access: No transportation access is impacted by the plan.

Natural Resources: The updated Wastewater Treatment Plant Master Plan doesn't specifically address how facility siting will affect natural resources. However, the improvements will be within a confined previously disturbed area and the City has regulations in place to look at conservation of resources during the design and final siting of future improvements.

Public Need for Healthful, Safe and Aesthetic Surroundings and Conditions: Functional and sanitary treatment of wastewater, which is the aim of the updated Wastewater Treatment Plant Master Plan, supports healthful, safe, and aesthetic surroundings by

preventing unsanitary or environmentally detrimental disposal or treatment of wastewater.

e. Conflict with Metro Requirements

- CP5. **Review Criteria:** “Proposed changes or amendments to the Comprehensive Plan do not result in conflicts with applicable Metro requirements.”
Finding: These criteria are satisfied.
Explanation of Finding: No conflicts with Metro requirements have been identified.

Citizen Involvement

Goal 1.1: To encourage and provide means for interested parties to be involved in land use planning processes, on individual cases and City-wide programs and policies.

Policy 1.1.1: Wide Range of Public Involvement

- CP6. **Review Criterion:** “The City of Wilsonville shall provide opportunities for a wide range of public involvement in City planning programs and processes.”
Finding: This criterion is satisfied.
Explanation of Finding: A number of different media and venues have been used to encourage public involvement. Wastewater treatment tends to be a subject in which the community does not express a lot of interest as long as the system is functioning well. While a reasonable effort has been made to notify and solicit community involvement, limited interest has been expressed. Information was published in the Boones Ferry Messenger, a community newsletter mailed to every address within Wilsonville’s 97070 zip code, the Planning Commission held work sessions, and project staff made information about the project available on the City’s website. Required public noticing for the Planning Commission and upcoming City Council public hearings has occurred.

Implementation Measure 1.1.1.a. Early Public Involvement

- CP7. **Review Criterion:** “Provide for early public involvement to address neighborhood or community concerns regarding Comprehensive Plan and Development Code changes. Whenever practical to do so, City staff will provide information for public review while it is still in “draft” form, thereby allowing for community involvement before decisions have been made.”
Finding: This criterion is satisfied.
Explanation of Finding: The City solicited feedback from the Planning Commission and public early in the planning process while the plan was still in draft form. Any feedback has been considered in preparation of the plan.

Goal 1.2: For Wilsonville to have an interested, informed, and involved citizenry.

Policy 1.2.1: User Friendly Information

CP8. **Review Criterion:** “The City of Wilsonville shall provide user-friendly information to assist the public in participating in the City planning programs and processes.”

Finding: This criterion is satisfied.

Explanation of Finding: The City has produced user-friendly notices for the project, as well as provided other information, and opportunities, both in person and online, to examine the materials related to the updated Wastewater Treatment Plant Master Plan.

Implementation Measures 1.2.1.a.-c. Clarification, Publicity, and Procedures for Public Involvement

CP9. **Review Criteria:** These measures address the City’s responsibility to help clarify the public participation process, publicize ways to participate, and establish procedures to allow reasonable access to information.

Finding: These criteria are satisfied.

Explanation of Finding: The City has produced user-friendly notices for the project, as well as provided other information, and opportunities, both in person and online, to examine the materials related to the updated Wastewater Treatment Plant Master Plan.

Policy 1.3.1. Implementation Measures 1.3.1.b. Clarification, Publicity, and Procedures for Public Involvement

CP10. **Review Criteria:** “The City of Wilsonville shall coordinate with other agencies and organizations involved with Wilsonville’s planning programs and policies.” “Where appropriate, the City shall continue to coordinate its planning activities with affected public agencies and private utilities. Draft documents will be distributed to such agencies and utilities and their comments shall be considered and kept on file by the City.”

Finding: These criteria are satisfied.

Explanation of Finding: The appropriate agencies have been notified through the DLCD notice and/or the Public Hearing Notice. Any comments will be entered into the public hearing record and be considered.

Urban Growth Management

Goal 2.1: To allow for urban growth while maintaining community livability, consistent with the economics of development, City administration, and the provision of public facilities and services.

Implementation Measure 2.1.1.d. Establish and Maintain Revenue Sources for Public Services and Facilities

CP11. **Review Criterion:** “Establish and maintain revenue sources to support the City’s policies for urbanization and maintain needed public services and facilities.”

Finding: This criterion is satisfied.

Explanation of Finding: While the scope of the Wastewater Treatment Plant Master Plan includes prioritizing short-term and long-term projects for the Capital Improvement Program and developing budget level cost estimates, the update does not evaluate funding tools. The City is examining and will continue to examine revenue sources to support the CIP.

Implementation Measure 2.1.1.e. Concurrency of Facilities and New Development

CP12. **Review Criterion:** “Allow new development to proceed concurrently with the availability of adequate public services and facilities as specified in Public Facilities and Services Section (Section C) of the Comprehensive Plan.”

Finding: This criterion is satisfied.

Explanation of Finding: The City’s current policies supporting concurrency of public services and facilities with new development are not altered by the proposed update to the Wastewater Treatment Plant Master Plan.

Policy 2.2.1. Plan for Urbanization

CP13. **Review Criterion:** “The City of Wilsonville shall plan for the eventual urbanization of land within the local planning area, beginning with land within the Urban Growth Boundary.”

Finding: This criterion is satisfied.

Explanation of Finding: By updating the plan for wastewater treatment infrastructure, including ensuring adequate capacity and service to land within the Urban Growth Boundary and Urban Reserves around the City, the City is supporting the effort to plan for the eventual urbanization of these areas.

Implementation Measure 2.2.1.b. Fair Share to Increase Development Capacity

CP14. **Review Criterion:** “The City of Wilsonville, to the best of its ability based on infrastructure provided at the local, regional, and state levels, shall do its fair share to increase the development capacity of land within the Metro UGB.”

Finding: This criterion is satisfied.

Explanation of Finding: By updating the plan for wastewater treatment infrastructure, including ensuring adequate capacity and service for planned densities, the City is supporting the effort to provide for its fair share of development within the UGB.

Implementation Measure 2.2.1.g. Urban Services to Not be Extended Outside City Limits

CP15. **Review Criterion:** “Urban sanitary sewer and water service shall not be extended outside the City limits, with the following exceptions:

1. Where an immediate demonstrable threat to the public health exists, as a direct result of the lack of the service in question;
2. Where a Governmental agency is providing a vital service to the City; or

3. Where it is reasonable to assume that the subject area will be annexed to the City within a reasonable period of time.”

Finding: This criterion is satisfied.

Explanation of Finding: The updated Wastewater Treatment Plant Master Plan does not allow for or encourage provision of City services outside City limits.

Public Facilities and Services

Goal 3.1 *To assure that good quality public facilities and services are available with adequate, but not excessive, capacity to meet community needs, while also assuring that growth does not exceed the community’s commitment to provide adequate facilities and services.*

Policy 3.1.1. The City to Provide Public Facilities

- CP16. **Review Criterion:** “The City of Wilsonville shall provide public facilities to enhance the health, safety, educational, and recreational aspects of urban living.”

Finding: This criterion is satisfied.

Explanation of Finding: By updating the plan for wastewater treatment infrastructure, including ensuring adequate capacity for land within the Urban Growth Boundary and Urban Reserves around the City, the City is supporting the effort to continue to provide for all aspects of urban living affected by wastewater treatment.

Implementation Measure 3.1.1.a. City to Prepare and Implement Facility/Services Master Plans

- CP17. **Review Criterion:** “The City will continue to prepare and implement master plans for facilities/services, as sub-elements of the City’s Comprehensive Plan. Facilities/services will be designed and constructed to help implement the City’s Comprehensive Plan.”

Finding: This criterion is satisfied.

Explanation of Finding: The City is continuing the practice to prepare and implement facility/services master plans as sub-elements of the Comprehensive Plan by updating the 19-year-old Wastewater Treatment Plant Master Plan.

Implementation Measure 3.1.1.d. City to Review Development Densities and Facilities/Services Capacity

- CP18. **Review Criterion:** “The City shall periodically review and, where necessary, update its development densities indicated in the land use element of the Plan, based on the capacity of existing or planned services and/or facilities.”

Finding: This criterion is satisfied.

Explanation of Finding: The updated Wastewater Treatment Plant Master Plan incorporates the most up to date growth forecast information to plan enough capacity for the expected growth; it has not identified any areas where planned development densities need to be adjusted based on the capacity to serve with the waste water treatment plant.

Policy 3.1.2. Concurrency

CP19. **Review Criterion:** “The City of Wilsonville shall provide, or coordinate the provision of, facilities and services concurrent with need (created by new development, redevelopment, or upgrades of aging infrastructure).”

Finding: This criterion is satisfied.

Explanation of Finding: By updating the Wastewater Treatment Plant Master Plan the City is coordinating its efforts over the planning horizon to provide wastewater treatment facilities and services concurrent with need, whether it involves new development, redevelopment, or upgrading aging infrastructure.

Implementation Measure 3.1.2.a. Urban Development only in Serviceable Areas

CP20. **Review Criterion:** “Urban development will be allowed only in areas where necessary facilities and services can be provided.”

Finding: This criterion is satisfied.

Explanation of Finding: In addition to analyzing the condition of existing infrastructure the updated Wastewater Treatment Plant Master Plan identifies deficiencies and needed improvements to serve areas expected to develop. The City will continue to follow concurrency policies for public facilities and development and thus allow development only in areas where wastewater treatment services can be provided.

Policy 3.1.3. Payment for and Benefits from Facilities and Services

CP21. **Review Criterion:** “The City of Wilsonville shall take steps to assure that the parties causing a need for expanded facilities and services or those benefiting from such facilities and services, pay for them.”

Finding: This criterion is satisfied.

Explanation of Finding: The City’s current practices to require parties causing a need for expanded facilities pay for them are not changed by the scope of the updated Wastewater Treatment Plant Master Plan.

Implementation Measure 3.1.3.a. Developers and SDC’s

CP22. **Review Criterion:** “Developers will continue to be required to pay for demands placed on public facilities/services that are directly related to their developments. The City may establish and collect systems development charges (SDCs) for any or all public facilities/services, as allowed by law. An individual exception to this standard may be justified, or SDC credits given, when a proposed development is found to result in public benefits that warrant public investment to support the development.”

Finding: This criterion is satisfied.

Explanation of Finding: The City’s current SDC practices are not affected by the updated Wastewater Treatment Plant Master Plan.

Implementation Measure 3.1.3.b. Capital Improvement Program

CP23. **Review Criterion:** “The City will continue to prepare and implement a rolling five- year Capital Improvement Program, with annual funding decisions made as part of the municipal budget process.”

Finding: This criterion is satisfied.

Explanation of Finding: The updated Wastewater Treatment Plant Master Plan is part of the City’s continuing effort to prepare and implement a rolling five-year Capital Improvement Program by prioritizing short-term and long-term wastewater treatment plant projects for the CIP.

Implementation Measure 3.1.3.c. Pay-back Agreements

CP24. **Review Criterion:** “The City shall continue to employ pay-back agreements, development agreements, and other creative solutions for facilities that are over-sized or extended from off-site at the expense of only some of the benefited properties.”

Finding: This criterion is satisfied.

Explanation of Finding: The City’s policies towards and use of pay-back agreements, development agreements, and other creative infrastructure financing solutions are not affected by the updated Wastewater Treatment Plant Master Plan.

Policy 3.1.4. City Operations of Sanitary System to Standards

CP25. **Review Criterion:** “The City of Wilsonville shall continue to operate and maintain the wastewater treatment plant and system in conformance with federal, state, and regional water quality standards.”

Finding: This criterion is satisfied.

Explanation of Finding: The updated Wastewater Treatment Plant Master Plan will continue to allow the wastewater system to operate to applicable standards.

Implementation Measure 3.1.4.a. City to Maintain Sewer Service Monitoring and Expansion Program

CP26. **Review Criterion:** “The City shall continue to maintain a sewer service capacity monitoring and expansion program to assure that adequate treatment and trunk main capacity is available to serve continued development, consistent with the City's urban growth policies and the concurrency standards noted above.”

Finding: This criterion is satisfied.

Explanation of Finding: By updating the plan for wastewater treatment infrastructure, including ensuring adequate capacity and service to land within the Urban Growth Boundary and Urban Reserves around the City, the City is supporting this implementation measure.

Implementation Measures 3.1.4.b. Sanitary Sewer Capacity

CP27. **Review Criteria:** “The City shall continue to manage growth consistent with the capacity of sanitary sewer facilities.”

Finding: These criteria are satisfied.

Explanation of Finding: An updated Wastewater Treatment Plant Master Plan will enable the City to better manage growth consistent with the capacity of the wastewater treatment plant by identifying needed upgrades to current infrastructure as well as infrastructure needed for growth in different planned growth areas.

Implementation Measure 3.1.4.e. All Urban Development Served by Sanitary Sewer

CP28. **Review Criterion:** “The City shall continue to require all urban level development to be served by the City's sanitary sewer system.”

Finding: This criterion is satisfied.

Explanation of Finding: By updating the plan for wastewater treatment infrastructure, including ensuring adequate capacity for land within the Urban Growth Boundary and Urban Reserves around the City, the City is supporting the ability to provide sanitary sewer service to all urban level development. The updated Wastewater Treatment Plant Master Plan does not affect the City’s policy of requiring sanitary sewer system service as part of urban level development approval.

Implementation Measure 3.1.4.f. Cost of Individual Services and Line Extensions

CP29. **Review Criterion:** “The cost of all line extensions and individual services shall be the responsibility of the developer and/or property owners(s) seeking service. When a major line is to be extended, the City may authorize and administer formation of a Local Improvement District (LID). All line extensions shall conform to the City Sanitary Sewer Collection System Master Plan, urbanization policies, and Public Works Standards.”

Finding: This criterion is satisfied.

Explanation of Finding: The City’s current practices regarding LID’s and costs for services are not affected by the updated Wastewater Treatment Plant Master Plan.

Parks/Recreation/Open Space, Environmental Resources and Community Design

Policies 3.1.11., 4.1.5. and Implementation Measures 3.1.11.a. ,4.1.5.d.-g.,aa. . Conservation of Natural, Scenic, and Historic Areas

CP30. **Review Criteria:** These policies and implementation measures require and encourage conservation of natural resources, as well as scenic and historic areas.

Finding: These criteria are satisfied.

Explanation of Finding: The updated Wastewater Treatment Plant Master Plan doesn’t specifically address how facility siting will affect natural resources. However, the improvements will be within a confined previously disturbed area and the City has

regulations in place to look at conservation of resources during the design and final siting of future improvements.

COMPLIANCE WITH PLANNING AND LAND DEVELOPMENT ORDINANCE
--

Section 4.003 Consistency with Plans and Laws

- PL1. **Review Criterion:** “Actions initiated under this Code shall be consistent with the Comprehensive Plan and with applicable State and Federal laws and regulations as these plans, laws and regulations now or hereafter provide.”
Finding: This criterion is satisfied.
Explanation of Finding: Consistency with the Comprehensive Plan and applicable state laws has been reviewed and summarized in this report.

Section 4.008 General Application Procedures

- PL2. **Review Criterion:** “The general application procedures listed in Section 4.008 through 4.024 apply to all land use and development applications governed by Chapter 4 of the Wilsonville Code. These include applications for all of the following types of land use or development approvals:
 H. Changes to the text of the Comprehensive Plan, including adoption of new Plan elements or sub-elements, pursuant to Section 4.198;”
Finding: This criterion is satisfied.
Explanation of Finding: Adoption of the updated Wastewater Treatment Plant Master Plan is being reviewed pursuant to Section 4.198.

Subsection 4.009 (.02) Who Can Initiate Application

- PL3. **Review Criterion:** “Applications involving large areas of the community or proposed amendments to the text of this Chapter or the Comprehensive Plan may be initiated by any property owner, business proprietor, or resident of the City, as well as the City Council, Planning Commission, or Development Review Board acting by motion.”
Finding: This criterion is satisfied.
Explanation of Finding: The application has been initiated by the City as part of its responsibility to periodically update facility master plans.

Subsection 4.032 (.01) B. Authority of Planning Commission

- PL4. **Review Criterion:** This Section states that the Planning Commission has authority to make recommendations to the City Council on “legislative changes to, or adoption of new elements or sub-elements of the Comprehensive Plan.”
Finding: This criterion is satisfied.

Explanation of Finding: The proposed legislative change is being considered by the Planning Commission as a recommendation to the City Council. The issue before the Planning Commission is a legislative review of an amended sub-element of the Comprehensive Plan.

Subsection 4.033 (.01) B. Authority of City Council

PL5. **Review Criterion:** This Section states that the City Council has final decision-making authority on “applications for amendments to, or adoption of new elements or sub-elements to the maps or text of the Comprehensive Plan, as authorized in Section 4.198.”

Finding: This criterion is satisfied.

Explanation of Finding: Final action will be taken by the City Council following a recommendation from the Planning Commission.

Subsection 4.198 (.01) A. Comprehensive Plan Changes: Public Need

PL6. **Review Criterion:** “That the proposed amendment meets a public need that has been identified;”

Finding: This criterion is satisfied.

Explanation of Finding: It is in the public interest to periodically update the master plans for critical public facilities such as the wastewater treatment plant to ensure the system provides for adequate service for current and future residents and businesses to ensure proper sanitation.

Subsection 4.198 (.01) B. Comprehensive Plan Changes: Meets Public Needs As Well As Other Options

PL7. **Review Criterion:** “That the proposed amendment meets the identified public need at least as well as any other amendment or change that could reasonably be made;”

Finding: This criterion is satisfied.

Explanation of Finding: As a sub-element of the Comprehensive Plan the Wastewater Treatment Plant Master Plan aims to provide for the public need of adequate wastewater treatment service. An updated Wastewater Treatment Plant Master Plan better meets the public need than the current plan by using updated information about the condition of existing infrastructure and growth projections.

Subsection 4.198 (.01) C. Comprehensive Plan Changes: Statewide Planning Goals

PL8. **Review Criterion:** “That the proposed amendment supports applicable Statewide Planning Goals or a Goal exception has been found to be appropriate; and;”

Finding: This criterion is satisfied.

Explanation of Finding: Please see compliance with Statewide Planning Goals section below.

Subsection 4.198 (.01) D. Comprehensive Plan Changes: Conflict with Other Portions of the Comprehensive Plan

PL9. **Review Criterion:** “That the proposed change will not result in conflicts with any portion of the Comprehensive Plan that is not being amended.”

Finding: This criterion is satisfied.

Explanation of Finding: No conflicts between the updated Wastewater Treatment Plant Master Plan and other portions of the Comprehensive Plan have been identified.

COMPLIANCE WITH OREGON STATEWIDE PLANNING GOALS
--

Statewide Planning Goals

Goal 1 Citizen Involvement

OR1. **Review Criterion:** “To develop a citizen involvement program that insures the opportunity for citizens to be involved in all phases of the planning process.”

Finding: This criterion is satisfied.

Explanation of Finding: The citizen involvement process defined in Wilsonville’s Comprehensive Plan has been acknowledged to be in conformance with Goal 1. Findings CP6 through CP10 demonstrate compliance with the citizen involvement component of the Comprehensive Plan and thus Goal 1.

Goal 2 Land Use Planning

OR2. **Review Criterion:** “To establish a land use planning process and policy framework as a basis for all decision and actions related to use of land and to assure an adequate factual base for such decisions and actions.”

Finding: This criterion is satisfied.

Explanation of Finding: The City is currently in compliance with Goal 2 because it has an acknowledged Comprehensive Plan and regulations implementing the plan. The Wastewater Treatment Plant Master Plan is a sub-element supporting this plan. A Wastewater Treatment Plant Master Plan will continue to be a sub-element of the Comprehensive Plan and the scope of the update will not change conformance with this goal, but rather provide updated information to better support land use planning in Wilsonville.

Goal 5 Natural Resources, Scenic and Historic Areas, and Open Spaces

OR3. **Review Criterion:** “To protect natural resources and conserve scenic and historic areas and open spaces.”

Finding: This criterion is satisfied.

Explanation of Finding: The updated Wastewater Treatment Plant Master Plan doesn’t specifically address how facility siting will affect natural resources. However, the

improvements will be within a confined previously disturbed area and the City has regulations in place to look at conservation of resources during the design and final siting of future improvements.

Goal 6 Air, Water and Land Resource Quality

OR4. **Review Criteria:** “To maintain and improve the quality of the air, water and land resources of the state.”

Finding: These criteria are satisfied.

Explanation of Finding: The proposed updated Wastewater Treatment Plant Master Plan provides for sanitary disposal of wastewater to prevent the wastewater from polluting and degrading water and land resources. It supports the planning guideline of this rule to only designate residential use where approvable sewage disposal alternatives have been clearly identified.

Goal 7 Areas Prone to Natural Disasters and Hazards

OR5. **Review Criteria:** “To protect life and property from natural disasters and hazards.”

Finding: These criteria are satisfied.

Explanation of Finding: The wastewater Treatment Plant has been evaluated for risks associated with natural disasters and hazards; see Chapter 2.

Goal 11 Public Facilities and Services

OR6. **Review Criteria:** “To plan and develop a timely, orderly and efficient arrangement of public facilities and services to serve as a framework for urban and rural development.”

Finding: These criteria are satisfied.

Explanation of Finding: The updated Wastewater Treatment Plant Master Plan is among the utility plans that are sub-elements of the City’s Comprehensive Plan. Using updated information on the condition of existing infrastructure as well as updated growth forecasts will better enable the timely, orderly and efficient arrangement of wastewater treatment facilities and services.

Oregon Administrative Rules

Division 660 Public Facilities Planning

OAR 660-11-0010 The Public Facility Plan

OR7. **Review Criteria:** This OAR identifies what a Public Facility Plan, such as the updated Wastewater Collection System Master Plan, must contain.

Finding: These criteria are satisfied.

Explanation of Finding: The updated Wastewater Treatment Plant Master Plan inventories and assesses Wilsonville’s wastewater treatment plant in support of current

and planned land uses; and it includes a list of projects and prioritized projects for short-term and long-term improvements, budget-level cost estimates of projects. The master plan also identifies the City as the service provider in City limits and in areas expected to be annexed into the City in the future. A discussion of the City's funding mechanisms is included in the Comprehensive Plan, but is not affected by this update.

OAR 660-11-0015 Responsibility for Public Facility Plan Preparation

OR8. **Review Criteria:** This OAR identifies who is responsible for preparing public facility plans.

Finding: These criteria are satisfied.

Explanation of Finding: The City of Wilsonville has the responsibility to prepare facility plans for public facilities including the wastewater treatment plant. An existing facility plan, which is a sub-element of the City of Wilsonville's Comprehensive Plan, is being updated to ensure an up-to-date facility plan.

OAR 660-11-0020 Public Facility Inventory and Determination of Future Facility Projects

OR9. **Review Criteria:** This OAR identifies components of public facility inventories.

Finding: These criteria are satisfied.

Explanation of Finding: The updated Wastewater Treatment Plant Master Plan includes an inventory of the City's wastewater treatment plant including all the required components listed in this OAR: information on capacity and size, assessment of conditions, identification of projects supportive of the City's Comprehensive Plan land use designations, and acknowledgment of future flexibility based on impact studies, facility design, and further master planning efforts.

OAR 660-11-0025 Timing of Required Public Facilities

OR10. **Review Criteria:** This OAR requires public facility plans include a general estimate of the timing for planned public facility projects.

Finding: These criteria are satisfied.

Explanation of Finding: The updated Wastewater Treatment Plant Master Plan includes information on short-term and long-term projects. See Chapter 7.

OAR 660-11-0030 Location of Public Facility Projects

OR11. **Review Criteria:** This OAR requires public facility plans include a general location of projects

Finding: These criteria are satisfied.

Explanation of Finding: The updated Wastewater Treatment Plant Master Plan includes information on project location.

OAR 660-11-0035 Determination of Rough Cost Estimates

OR12. **Review Criteria:** This OAR requires public facility plans include rough cost estimates for projects.

Finding: These criteria are satisfied.

Explanation of Finding: The scope of the updated Wastewater Treatment Plant Master Plan includes budget level cost estimates for identified projects.

OAR 660-11-0045 Adoption and Amendment Procedures for Public Facility Plans

OR13. **Review Criteria:** This OAR identifies public facility plans as supporting documents to the comprehensive plan and identifies related items to be in the comprehensive plan.

Finding: These criteria are satisfied.

Explanation of Finding: The Wastewater Treatment Plant Master Plan is a sub-element of the City of Wilsonville's Comprehensive Plan and includes a list of projects, a map of projects, and policies on urban growth and the provision public facilities. The updated Master Plan is being considered a land use decision with the appropriate noticing and hearing processes being followed.

LP22-0001
Wastewater Treatment Plant Master Plan
Planning Commission Public Hearing Record Index
DRAFT (December 13, 2023)

PLANNING COMMISSION AND CITY COUNCIL MEETINGS

December 13, 2023 - Planning Commission Public Hearing
Resolution LP22-0001 (*included above, adoption pending*)
Staff Report and Attachments (*included above, adoption pending*)
Presentation (*not included at this time*)
Affidavit of Notice of Hearing

November 6, 2023 - City Council Work Session
Staff Report and Attachments
Presentation
Action Minutes

October 11, 2023 - Planning Commission Work Session
Staff Report and Attachments
Presentation
Minutes Excerpt

October 12, 2022 - Planning Commission Public Hearing - Cancelled
Cancellation Memo
Minutes Excerpt

September 14, 2022 - Planning Commission Work Session
Staff Report and Attachments
Presentation
Minutes Excerpt

August 1, 2022 - City Council Work Session
Staff Report and Attachments
Presentation
Action Minutes

July 13, 2022 - Planning Commission Work Session
Staff Report and Attachments
Presentation
Minutes Excerpt

PUBLIC ENGAGEMENT

Project Website: <https://www.letstalkwilsonville.com/wastewater-treatment-plant-master-plan>

Open House - September 28, 2022: <https://www.ci.wilsonville.or.us/engineering/page/public-open-house-waste-water-treatment-plant-master-plan>

LP22-0001
Wastewater Treatment Plant Master Plan
Planning Commission Public Hearing Record Index
DRAFT (December 13, 2023)

COMMENTS/ARTICLES

Boones Ferry Messenger – September

Spokesman Article for Original Public Hearing notification and cancellation

Emailed Comment 10/2/2022 – Thomas Hooker



PLANNING COMMISSION

WEDNESDAY, DECEMBER 13, 2023

PUBLIC HEARING

2. Wastewater Treatment Plant Master Plan (Nacrelli) (30 minutes)

AFFIDAVIT OF MAILING AND POSTING NOTICE OF PUBLIC HEARING IN THE CITY OF WILSONVILLE

STATE OF OREGON)

COUNTIES OF CLACKAMAS)
AND WASHINGTON)

CITY OF WILSONVILLE)

I, Mandi Simmons, do hereby certify that I am Administrative Assistant for the City of Wilsonville, Counties of Clackamas and Washington, State of Oregon, that the attached copy of Notice of Public Hearing is a true copy of the originals of the following that I did cause to be mailed/displayed copies of said public hearing in the exact form hereto attached:

- Single-paged notice was emailed on November 22, 2023 to the attached list of affected agencies
- Single-paged notice was emailed on November 22, 2023 to the attached list of interested parties
- Single-paged notice was sent to the Wilsonville Spokesman for publication in the November 30, 2023 newspaper issue
- The content of the notice was posted on November 22, 2023 on the City’s website
- Single-paged notice was posted at physical locations listed below on November 22, 2023
 - City Hall, 29799 SW Town Center Loop, East, Wilsonville OR 97070
 - Wilsonville Community Center, 7965 SW Wilsonville Road, Wilsonville, OR 97070
 - Library, 8200 SW Wilsonville Road, Wilsonville OR 97070

Witness my hand this 4th day of December 2023

Mandi Simmons, Administrative Assistant

Acknowledged before me this 4th day of December 2023, in Clackamas County, Oregon

Signature of Oregon Notary

Tamara E. Callaway
Printed Notary Name

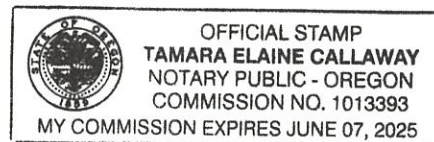

NOTARY PUBLIC

My Commission Expires 6/7/25

NOTICE OF LEGISLATIVE PUBLIC HEARING BEFORE THE PLANNING COMMISSION AND CITY COUNCIL

WASTEWATER TREATMENT PLANT (WWTP) MASTER PLAN LP22-0001

OREGON STATE LAW ORS 227.186. The City has not determined how or if this particular proposal will reduce or otherwise impact either the value or use of properties within Wilsonville. Any changes to permitted land uses may reduce or increase property values, depending on various factors. A written notice has been mailed to potentially impacted property owners as required.

PLANNING COMMISSION

On **Wednesday, December 13, 2023, beginning at 6 pm**, the Planning Commission will hold a public hearing on **the Wastewater Treatment Plant Master Plan**, and will consider whether to recommend to City Council adoption of the Plan.

You will not receive another mailed notice unless you: submit a request in writing or by phone, or submit testimony or sign-in at the hearing.

CITY COUNCIL

On **Thursday, January 4, 2024 beginning at 7 pm**, the City Council will hold a public hearing regarding **the Wastewater Treatment Plant Master Plan** after which it may make the final decision.

The hearings will take place at **Wilsonville City Hall**, 29799 SW Town Center Loop East. A complete copy of the project record, including staff report, findings, and recommendations, will be available online and at City Hall for viewing 7 days prior to each public hearing.

SUMMARY OF PROPOSAL

The City of Wilsonville is updating its Wastewater Treatment Plant Master Plan. The improvements detailed in this Plan are designed to provide optimal value to the City's ratepayers by maximizing the use of existing infrastructure and improving system operation while continuing to protect water quality and human health and supporting economic development.

The City's Wastewater Treatment Plant, along I-5 between the river and Old Town, was originally built in 1971. A major 2014 upgrade expanded the capacity to accommodate population growth. This Plan, which satisfies requirements established by the State of Oregon Department of Environmental Quality (DEQ), considers:

- The age and condition of existing process equipment and structures
- Upgrades to accommodate population growth and new economic development over the planning period (through 2045). Projections are based on land use, historical data, and DEQ wet weather flow methodologies.
- Potential changes to water quality regulations established by the DEQ
- City of Wilsonville Wastewater Collection System Master Plan (2014), and
- Consistency with the 2018 Comprehensive Plan and City Council 2021-2023 Goals 5, 6 and 7

For more details, visit <https://www.letstalkwilsonville.com/wastewater-treatment-plant-master-plan>

HOW TO COMMENT: Oral or written testimony may be presented at the public hearings. Written comment on the proposal is welcome prior to the public hearings. To have your written comments or testimony distributed to the Planning Commission before the meeting, it must be received by 2 pm on December 5, 2023. **Direct written comments to Mandi Simmons, Administrative Assistant** 29799 SW Town Center Loop East, Wilsonville, Oregon, 97070 | msimmons@ci.wilsonville.or.us | (503) 682-4960

Note: Assistive Listening Devices (ALD) are available for persons with impaired hearing and can be scheduled for this meeting. The City will also endeavor to provide qualified sign language interpreters and/or bilingual interpreters, without cost, if requested at least 48 hours prior to the meeting. To obtain such services, please call Mandi Simmons, Administrative Assistant at (503) 682-4960.

Pat McGough
West Linn/Wilsonville School District 3J
2755 SW Borland Road
Tualatin, OR 97062

Andy Back
Wash. County Long Range Planning
155 N. First Avenue
Hillsboro, OR 97124

Steve Koper
City of Tualatin
18880 SW Martinazzi Avenue
Tualatin, OR 97062

Attn: Development Review
ODOT Region 1
123 NW Flanders Street
Portland, OR 97209

Ben Baldwin
Tri-Met Project Planning Dept
4012 SE 17th Avenue
Portland, OR 97202

Bill Ferber, Region Manager
Oregon Water Resources Department
725 Summer Street, NE
Salem, OR 97301

Dr. Kathy Ludwig
West Linn/Wilsonville School District 3J
22210 SW Stafford Road
Tualatin, OR 97062

Tracy Wilder, Department of Corrections
Facilities Services
3601 State Street
Salem, Oregon 97301

Steve Hursh, Service & Design Supervisor
Portland General Electric
2213 SW 153rd Drive
Beaverton, OR 97006

Land Use Contact, Planning Department
Metro
600 NE Grand Ave
Portland, OR 97232

Nina Carlson
NW Natural Gas
250 SW Taylor St.
Portland, OR 97204

John Olivares, Operations Manager
Republic Services of Clackamas &
Washington Counties
10295 SW Ridder Road
Wilsonville, OR 97070

City Planner
City of Canby
P.O. Box 930
Canby, OR 97013

Diane Taniguchi-Dennis
Clean Water Services
2550 SW Hillsboro Hwy.
Hillsboro, OR 97123

Department of Corrections
2575 Center Street NE
Salem, OR 97310

John Lilly
Department of State Lands
775 Summer Street, NE
Salem, OR 97301

Roseann Johnson, Assistant Director of
Government Affairs
Home Builders Associations
15555 SW Bangy Road, Suite 301
Lake Oswego, OR 97035

Sherwood School Dist Admin Office
23295 SW Main Street
Sherwood, OR 97140

Clackamas County Planning Director
150 Beaver Creek Road
Oregon City, OR 97045

Oregon Dept of Environ Quality
700 NE Multnomah Street, Suite 600
Portland, OR 97232

Tualatin Valley Water District
1850 SW 170th Ave.
Beaverton, OR 97005

Planning Director
City of Sherwood
22560 SW Pine Street
Sherwood, OR 97140

James Clark
BPA, Realty Department
2715 Tepper Lane
Keizer, OR 97013

Tualatin Valley Fire and Rescue
29875 SW Kinsman Road
Wilsonville, OR 97070

Tualatin Valley Fire and Rescue
South Division
8445 SW Elligsen Road
Wilsonville, OR 97070

Elizabeth Kenney
12451 Orchard Hill Rd
Lake Oswego, OR 97035

PamplinMediaGroup

-Ad Proof-

This is the proof of your ad, scheduled to run on the dates indicated below. Please proofread carefully, and if changes are needed, please contact Sarah Penn prior to deadline at or spenn@pamplinmedia.com.

<p>Date: 11/22/23 Account #: 108863 Reference #: LP22-0001 WWTP MASTER PLAN Company Name: WILSONVILLE, CITY OF Contact: Address: 29799 SW TOWN CENTER LOOP E WILSONVILLE Telephone: (503) 570-1510 Fax: (503) 682-1015</p>	<p>Ad ID: 308944 Start: 11/29/23 Stop: 11/30/23 Total Cost: \$208.79 Ad Size: 12.069 Column Width: 1 Column Height: 12.069 Ad Class: 1202 Phone # Email: spenn@pamplinmedia.com</p>
--	--

Run Dates:

Wilsonville Spokesman 11/30/23

**NOTICE OF LEGISLATIVE PUBLIC HEARING
BEFORE THE
PLANNING COMMISSION AND CITY COUNCIL:**

**WASTEWATER TREATMENT PLANT (WWTP)
MASTER PLAN LP22-0001**

OREGON STATE LAW ORS 227.186. The City has not determined how or if this particular proposal will reduce or otherwise impact either the value or use of properties within Wilsonville. Any changes to permitted land uses may reduce or increase property values, depending on various factors. A written notice has been mailed to potentially impacted property owners as required.

PLANNING COMMISSION:

On **Wednesday, Dec. 13, 2023, beginning at 6 pm**, the Planning Commission will hold a public hearing on the **Wastewater Treatment Plant Master Plan**, and will consider whether to recommend to City Council adoption of the Plan.

You will not receive another mailed notice unless you: submit a request in writing or by phone, or submit testimony or sign-in at the hearing.

CITY COUNCIL:

On **Thursday, Jan. 4, 2024 beginning at 7 pm**, the City Council will hold a public hearing regarding the **Wastewater Treatment Plant Master Plan** after which it may make the final decision.

The hearings will take place at Wilsonville City Hall, 29799 SW Town Center Loop East. A complete copy of the project record, including staff report, findings, and recommendations, will be available online and at City Hall for viewing 7 days prior to each public hearing.

SUMMARY OF PROPOSAL:

The City of Wilsonville is updating its Wastewater Treatment Plant Master Plan. The improvements detailed in this Plan are designed to provide optimal value to the City's ratepayers by maximizing the use of existing infrastructure and improving system operation while continuing to protect water quality and human health and supporting economic development.

The City's Wastewater Treatment Plant, along I-5 between the river and Old Town, was originally built in 1971. A major 2014 upgrade expanded the capacity to accommodate population growth.

This Plan, which satisfies requirements established by the State of Oregon Department of Environmental Quality (DEQ), considers:

- The age and condition of existing process equipment and structures
- Growth to accommodate population growth and new economic development over the planning period (through 2045). Projections are based on projections, historical data and DEQ wet weather project methodologies.
- Potential changes to water quality regulations established by the DEQ
- City of Wilsonville Wastewater Collection System Master Plan (2014), and
- Consistency with the 2018 Comprehensive Plan and City Council 2021-2023 Goals 5, 6 and 7

For more details, visit <https://www.letstalkwilsonville.com/wastewater-treatment-plant-master-plan>.

HOW TO COMMENT:

Oral or written testimony may be presented at the public hearings. Written comment on the proposal is welcome prior to the public hearings. To have your written comments or testimony distributed to the Planning Commission before the meeting, it must be received by 2 pm on Dec. 5, 2023. Direct written comments to Mandi Simmons, Administrative Assistant 29799 SW Town Center Loop East, Wilsonville, Oregon, 97070 | msimmons@ci.wilsonville.or.us | (503) 682-4960

Note: Assistive Listening Devices (ALD) are available for persons with impaired hearing and can be scheduled for this meeting. The City will endeavor to provide qualified sign language interpreters and/or bilingual interpreters, without cost, if requested at least 48 hours prior to the meeting. To obtain such services, please call Mandi Simmons, Administrative Assistant at (503) 682-4960.

Publish November 30, 2023

WS308944



CITY COUNCIL
MONDAY, NOVEMBER 6, 2023

WORK SESSION

Wastewater Treatment Plant Master Plan (Nacrelli)



CITY COUNCIL MEETING STAFF REPORT

Meeting Date: November 6, 2023		Subject: Wastewater Treatment Plant Master Plan Update	
		Staff Member: Mike Nacrelli, Senior Civil Engineer	
		Department: Community Development	
Action Required		Advisory Board/Commission Recommendation	
<input type="checkbox"/> Motion <input type="checkbox"/> Public Hearing Date: <input type="checkbox"/> Ordinance 1 st Reading Date: <input type="checkbox"/> Ordinance 2 nd Reading Date: <input type="checkbox"/> Resolution <input checked="" type="checkbox"/> Information or Direction <input type="checkbox"/> Information Only <input type="checkbox"/> Council Direction <input type="checkbox"/> Consent Agenda		<input type="checkbox"/> Approval <input type="checkbox"/> Denial <input type="checkbox"/> None Forwarded <input checked="" type="checkbox"/> Not Applicable Comments: N/A	
Staff Recommendation: Review Wastewater Treatment Plant Master Plan updates and provide feedback on the recommended capital improvement plan.			
Recommended Language for Motion: N/A			
Project / Issue Relates To:			
<input checked="" type="checkbox"/> Council Goals/Priorities: Strategy 1. Develop an Infrastructure resilience plan and reprioritize/ fund recommended projects.	<input type="checkbox"/> Adopted Master Plan(s):	<input type="checkbox"/> Not Applicable	

ISSUE BEFORE COUNCIL:

The project team will provide an update on the additional analysis included in the Wastewater Treatment Plant (WWTP) Master Plan and the proposed changes made since the previous Council discussion on August 1, 2022.

EXECUTIVE SUMMARY:

The City of Wilsonville (City) Wastewater Treatment Plant (WWTP) Master Plan (the Plan) has been developed to satisfy requirements associated with the State of Oregon Department of Environmental Quality (DEQ) guidance document entitled “Preparing Wastewater Planning Documents and Environmental Reports for Public Utilities.” To accommodate future flows and loads, projections were developed based on population projections and referencing WWTP historical data and DEQ wet weather project methodologies. Similarly, to accommodate future water quality regulations, the Plan is adaptive and considers potential future regulatory changes.

The City prepared the Plan with the goal of developing a capital plan that identifies improvements required through the planning period (today through 2045) to comply with requirements of the WWTP National Pollutant Discharge Elimination System (NPDES) permit and potential future regulatory requirements, while accommodating growth identified in the City of Wilsonville Comprehensive Plan (October 2018, updated June 2020). These improvements are designed to provide the best value to the City’s ratepayers by maximizing the use of existing infrastructure and improving system operation while continuing to protect water quality and human health and supporting economic development, consistent with goals and policies contained in the Comprehensive Plan and 2023-2025 City Council Goals.

The City’s WWTP was originally built in 1971 and discharges treated effluent to the Willamette River. The WWTP underwent major upgrades in 2014 to expand the average dry weather capacity to four million gallons per day (mgd) to accommodate the City’s continued growth. The WWTP processes include headworks screening and grit removal facilities, aeration basins, stabilization basins, secondary clarifiers, biosolids processing, cloth filtration, and disinfection processes. Additionally, the City contracts with Jacobs for operation of the wastewater treatment plant, located at 9275 Southwest Tauchman Road.

This Plan identifies needed capital improvements within the planning period, taking into consideration:

- The age and condition of existing process equipment and structures,
- Growth in demand for sewer service due to increased population and economic development over the planning period,
- Potential changes to water quality regulations impacting process needs in order to meet effluent limitations and discharge prohibitions imposed by the Oregon Department of Environmental Quality (DEQ), and
- Consistency with the 2018 Comprehensive Plan and City Council 2023-2025 Strategy 1.

Plan Updates

Since the previous Council Work Session on August 1, 2022 growth projections have been updated to an assumed 2.9% annual population increase, consistent with recent planning documents adopted by the City, including the Wastewater Collection System Master Plan (November 2014), the Willamette River Water Treatment Plan Master Plan Update (March 2018), and the Basalt Creek Concept Plan (August 2018). In addition, the wastewater flow and load projections for biochemical oxygen demand (BOD) and total suspended solids (TSS) have been

further updated to account for increases in industrial discharges, as allowed under existing permits. The project team also performed a more in depth seismic and resiliency analysis of the wastewater treatment plant facilities to address the City Council 2023-2025 goal to develop an infrastructure resilience plan and reprioritize/ fund recommended projects. These changes result in a higher level of capital investment over the planning period than previously reported, as reflected in the table below.

Project Description	Timeframe	Cost*
Dewatering Performance Optimization	2025	\$150,000
Fiber Optic Conduit Addition	2025	\$60,000
UV System Improvement	2026	\$1,705,000
Seismic Improvements	2026	\$1,082,000
New Aeration Basin and Blower	2025 – 2027	\$10,222,000
Replace Secondary Clarifier Mechanisms	2026 - 2027	\$1,775,000
Membrane Bioreactor (MBR) Phase 1 (includes new blower, fine screens, electrical and hydraulic upgrades)	2028 – 2030	\$69,727,000
New Solids Dryer	2031 – 2033	\$17,130,000
Thickening and Dewatering Improvements	2031 – 2033	\$3,701,000
New Cooling Tower	2037 – 2038	\$642,000
MBR Phase 2 (includes new blower)	2037 – 2038	\$2,330,000
UV Equipment Replacement	2039 – 2040	\$2,571,000
Outfall Upsizing	2039 – 2040	\$1,244,000
MBR Phase 3 (includes 2 new blowers)	2042 – 2043	\$8,117,000
Total		\$120,456,000
*Costs are shown in 2023 dollars and include 25% for engineering, legal, and administration.		

The most significant impact to the required level of capital investment is the need for membrane bioreactor (MBR) facilities. These are state-of-the-art, compact facilities that provide a high level of treatment. Due to the limited amount of space available at the existing WWTP site, MBR facilities are the most feasible means of providing the necessary treatment to accommodate build out of the Wilsonville urban reserve areas.

EXPECTED RESULTS:

The Plan includes a list of recommended capital improvements, along with an anticipated schedule for completion and preliminary cost estimates. The total estimated amount of capital investment over the planning period is approximately \$120 million, of which \$15 million is anticipated in the next five (5) years. The recommended capital improvements will provide the basis for an analysis of sewer rates and system development charges (SDCs) that are necessary to adequately fund the upgrades needed to meet the projected growth.

TIMELINE:

The project team will incorporate feedback received by both the Planning Commission (October 11, 2023 Work Session) and the City Council (November 6, 2023 Work Session) into the Plan.

Currently, a public hearing for the Plan adoption recommendation by the Planning Commission is scheduled for December 13, 2023. A public hearing before City Council for the Plan adoption is anticipated in January 2024.

CURRENT YEAR BUDGET IMPACTS:

The amended fiscal year 2023 -2024 Budget for capital improvement project (CIP) #2104, Wastewater Treatment Plant Master Plan, includes \$130,000 in sewer operations and system development charge funds. The remaining budget is sufficient to complete the remaining work to update and adopt the Plan.

COMMUNITY INVOLVEMENT PROCESS:

A virtual town hall meeting to present the findings of the Plan and solicit public input was held in September 2022 and posted on the City's online calendar and Let's Talk Wilsonville page, where a project overview and periodic updates to the Executive Summary have also been posted. In addition, draft versions of the Executive Summary have been sent to the ten (10) largest industrial customers for review and comment. The public hearings listed above will provide further opportunity for public input. The forthcoming Sewer System Rate Study and SDC Update will also include a public engagement process with outreach to utility customers and the development community.

POTENTIAL IMPACTS OR BENEFIT TO THE COMMUNITY:

A technically and financially sound plan for providing reliable wastewater treatment, capacity to accommodate future development, and compliance with environmental regulations.

ALTERNATIVES:

The project team considered and evaluated numerous technologies and alternatives to provide the needed wastewater treatment plant capacity to meet future demands and recommend a capital improvement program that implements the needed improvements in a way that is efficient and cost effective.

CITY MANAGER COMMENT:

N/A

ATTACHMENT:

1. Wastewater Treatment Plant Master Plan Draft Executive Summary (dated October 2023)

EXHIBIT A

EXECUTIVE SUMMARY

This new City of Wilsonville (City) Wastewater Treatment Plant (WWTP) Master Plan (the Plan) has been developed to satisfy requirements associated with the State of Oregon Department of Environmental Quality (DEQ) guidance document entitled "Preparing Wastewater Planning Documents and Environmental Reports for Public Utilities." To accommodate future flows and loads, projections were developed based on population projections and referencing WWTP historical data and DEQ wet weather projection methodologies. Similarly, to accommodate future water quality regulations, the Plan is adaptive and considers potential future regulatory changes.

The City prepared the Plan with the goal of developing a capital plan that identifies improvements required through the planning period (today through 2045) to comply with requirements of the WWTP National Pollutant Discharge Elimination System (NPDES) permit and potential future regulatory requirements, while accommodating growth identified in the City of Wilsonville Comprehensive Plan (October 2018, updated June 2020 - the 2018 Comprehensive Plan). These improvements are designed to provide the best value to the City's ratepayers by maximizing the use of existing infrastructure and improving system operation while continuing to protect water quality and human health and supporting economic development, consistent with goals and policies contained in the 2018 Comprehensive Plan and 2021-2023 City Council Goals.

The City's WWTP was originally built in the early 1970's and discharges treated effluent to the Willamette River. The WWTP underwent major upgrades in 2014 to expand the average dry weather capacity to four million gallons per day (mgd) to accommodate the City's continued growth. The WWTP processes include headworks screening and grit removal facilities, aeration basins, stabilization basins, secondary clarifiers, biosolids processing, cloth filtration, and disinfection processes. Additionally, the City contracts with Jacobs for operation of the WWTP, located at 9275 Southwest Tauchman Road.

This Plan identifies improvements taking into consideration:

- The age and condition of existing process equipment and structures,
- Growth in demand for sewer service due to increased population and economic development over the planning period,
- Potential changes to water quality regulations impacting process needs in order to meet effluent limitations and discharge prohibitions imposed by DEQ,
- City of Wilsonville Wastewater Collection System Master Plan (2014, MSA), and
- Consistency with the 2018 Comprehensive Plan and City Council 2023-2025 Strategy 1.

ES.1 Planning Area Characteristics

Chapter 1 summarizes the City's wastewater service area characteristics relevant to assessing WWTP facility needs. The planning area considered by this Plan is consistent with the City's 2014 Collection System Master Plan and 2018 Comprehensive Plan including the urban growth boundary (UGB). The Basalt Creek Concept Plan, adopted in 2018, resulted in a modification of the future boundary between the cities of Tualatin and Wilsonville relative to the 2014 Wastewater Collection System Master Plan (CSMP). This decision is reflected in Figure ES.1, which shows the Study Area Boundary as analyzed in the 2014 CSMP, with the portion likely to annex to Tualatin now shown outside the current Study Area Boundary.

The northern portion of the City of Wilsonville is located within Washington County, and the majority of the City lies in the southwestern part of Clackamas County.

The City sits within the jurisdictional boundaries of Metro, the regional government for the Portland metropolitan area. By state law, Metro is responsible for establishing the Portland metropolitan area's UGB, which includes Wilsonville. Land uses and densities inside the UGB require urban services such as police and fire protection, roads, schools, and water and sewer systems. A figure of the City's existing land use is presented in Chapter 1. Also presented in

Chapter 1 are the City's physical characteristics, water resources, and population and employment information, which are all significant factors in planning for wastewater conveyance and treatment facilities.

EXECUTIVE SUMMARY | WASTEWATER TREATMENT PLANT MASTER PLAN | CITY OF WILSONVILLE

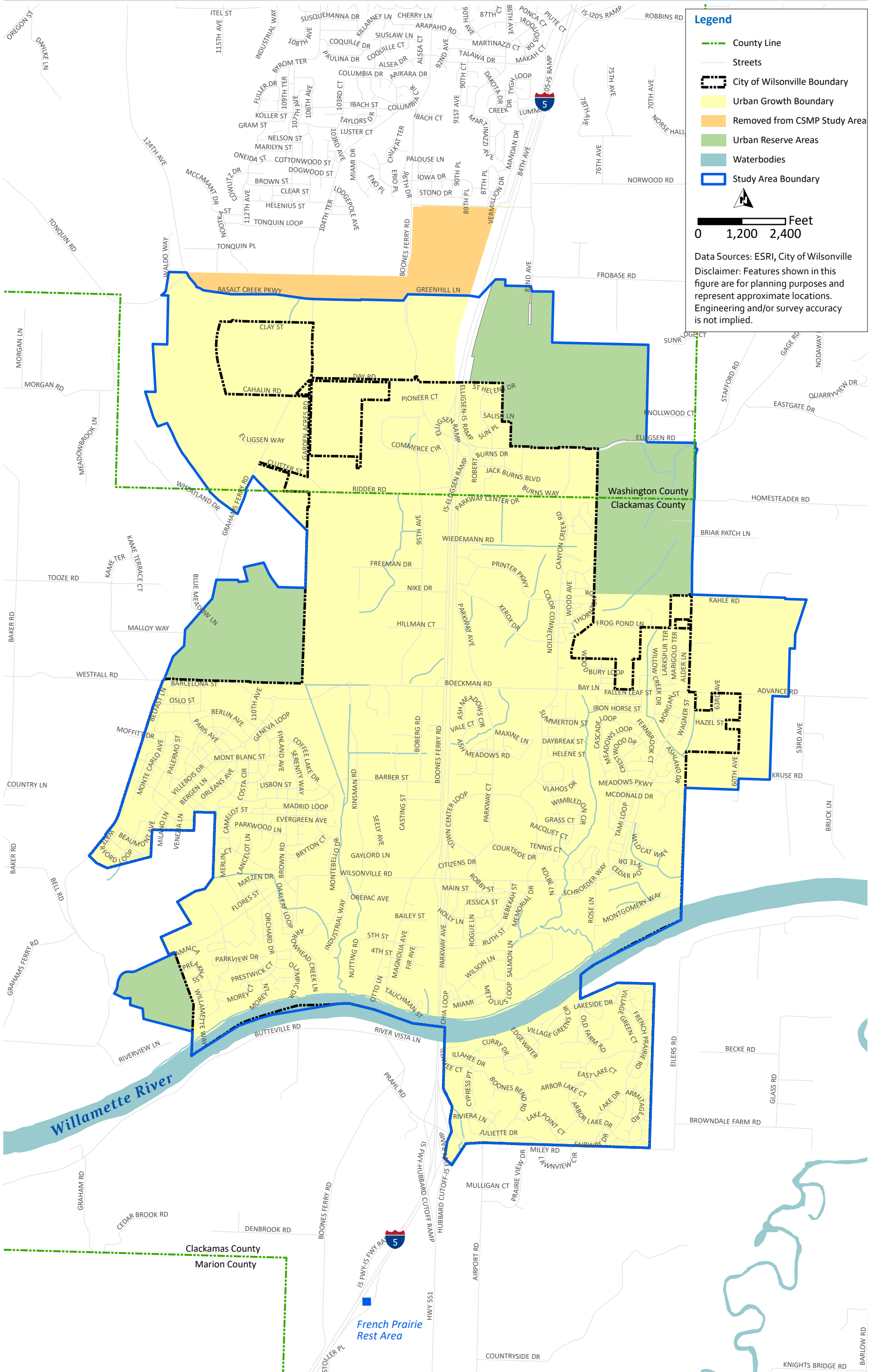

Legend

- County Line
- Streets
- City of Wilsonville Boundary
- Urban Growth Boundary
- Removed from CSMP Study Area
- Urban Reserve Areas
- Waterbodies
- Study Area Boundary

Feet
0 1,200 2,400

Data Sources: ESRI, City of Wilsonville
Disclaimer: Features shown in this figure are for planning purposes and represent approximate locations. Engineering and/or survey accuracy is not implied.

The Portland State University Population Research Center (PSU PRC) publishes annual estimates of populations for the previous year for cities in Oregon while Metro develops population projections for the future within the Portland metropolitan area, including Wilsonville. The PSU PRC estimated the City's population as 27,414 in 2022.

The historical per capita flow and loads presented in this master plan are based on the PSU PRC certified population estimates while future flow and load projections are based on the CSMP estimates to maintain consistency with prior water and sewer enterprise planning (with the slight modification to exclude the portion of the Basalt Creek Planning Area (BCPA) mentioned above). Figure ES.2 details the current population along with the historical population and growth expected for the City using the CSMP projections. As is shown in Figure ES.2, the WSMP (2003) assumption of a 2.9 percent growth rate lines up well with the PSU PRC and US census data for the years 2010 through 2022. Current and future population are described in greater detail in Chapter 3.

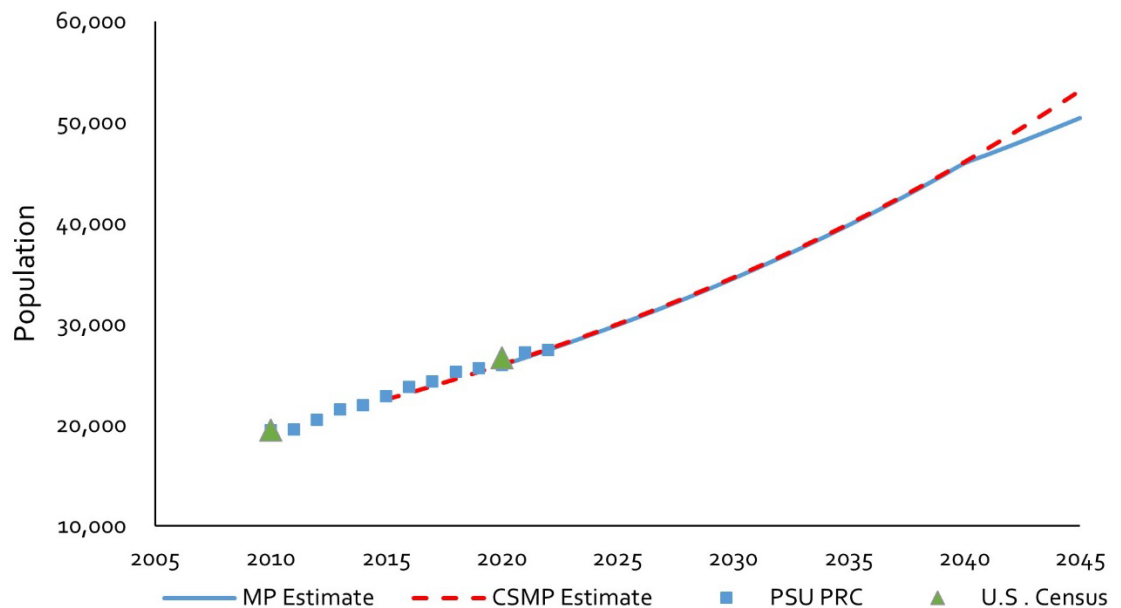

Figure ES.2 Historical Population and Expected Growth for the City of Wilsonville

ES.2 WWTP Condition Assessment

Carollo Engineers, Inc. (Carollo) reviewed prior condition assessments performed by others, conducted geotechnical investigations and performed seismic assessments at the WWTP in the course of Plan development.

In 2019, Jacobs Engineering Group Inc. (Jacobs) and Brown and Caldwell both completed condition assessments at the City's WWTP. A total of 322 major assets (per Jacobs' report), including process and mechanical equipment, motors and drives, control panels, generators, instrumentation, and structures, were examined for a variety of conditions that may signify their need for maintenance or replacement. Chapter 2 presents a summary of critical assets that require short term rehabilitation or replacement, as well as a list of assets that are less critical to operations, or have minor condition issues, but may be included in a short-term improvements project or a task order for Jacobs operations personnel. Table ES.1 displays the condition driven rehabilitation or replacement projects from Chapter 2 that were included in the recommended Capital Improvement Plan (CIP) in Chapter 7. The City undertook an updated assessment of WWTP condition in the summer of 2023. The 2023 assessment did not identify additional issues requiring significant capital outlays compared to the 2019 assessments.

Table ES.1 CIP Condition Driven Replacement Projects

Asset	Description
Trojan UV 4000 System	While only used as a backup to the Suez UV system, the Trojan system's HMI has errors that prevent it from showing the status of the lamps in module 3. Since it is used infrequently, the system's condition is largely unknown. After review of the 2019 condition assessment reports and discussion with the City and Jacobs staff, it was concluded that the UV 4000 unit must be replaced.
Secondary Clarifiers No. 1 and No. 2	Ovivo completed a field review of the plant's secondary clarifiers No. 1 and No. 2 in April 2022. Although both units were operational, repairs were identified to improve the operation of the clarifiers. The recommended repairs include drive controls for both units, new skimmers for both units, squeegees for both tanks rake arms, EDI chains, one motor and reducer assembly, one skimmer arm assembly, and new secondary clarifier mechanisms.

Notes:

Abbreviations: EDI - electronic data interchange; HMI - human-machine interface; No. - number; UV - ultraviolet.

ES.3 Seismic Analysis

In 2021, Carollo performed a seismic evaluation and analysis of the City's WWTP as part of the overall plant condition assessment. Because the WWTP was substantially upgraded and expanded in 2014, most of its infrastructure is designed in accordance with the 2010 Oregon Structural Specialty Code (OSSC) and follows modern seismic design and detailing. During Tier 1 evaluations, Carollo identified potential deficiencies and areas for additional investigation. A Tier 1 seismic analysis is an initial evaluation performed to identify any potential deficiencies, whether structural or non-structural, in a building based on the performance of other similar buildings in past earthquakes. Subsequent to the Tier 1 analysis, a more detailed seismic evaluation of five older and potentially seismically vulnerable structures on the WWTP site was conducted. Those structures receiving a more detailed evaluation included the following:

- Operations Building.
- Process Gallery.
- Workshop.
- Aeration Basins and Stabilization Basins.
- Sludge Storage Basins and Biofilter.

The five potentially vulnerable structures were compared against an S-4 Limited Safety structural performance level and N-B Position Retention non-structural performance level for an M9.0 Cascadia Seismic Zone (CSZ) earthquake. The M9.0 CSZ is reflective of a catastrophic natural disaster event that has an estimated 35 percent likelihood of occurring within the next 50 years. Following the Tier 1 evaluation, Carollo began Tier 2 evaluations for a select number of identified deficiencies. Although none of the structures showed significant irregularities, the team did identify seismic deficiencies. The recommended seismic retrofits are included in the CIP for this Plan.

Prior to the 2021 seismic evaluation, Carollo's subconsultant, Northwest Geotech, Inc. (NGI), completed a seismic response and geologic hazards assessment of the City's WWTP. Through past and present site investigations and engineering analyses, NGI determined that the native soils beneath the site's granular pit backfill have low risk of liquefaction and its slopes do not pose undue risk. NGI concluded that the WWTP's primary site hazard is the differential settlement that may be caused by soil piping (development of subsurface air-filled voids), which raises the risk of sinkholes forming beneath structures and pipelines. Soil piping usually develops in unsaturated soils when a water source percolates into the ground. While the site is mostly paved and stormwater is being collected, there may be areas where infiltration is occurring next to structures or below pipelines. In spring 2023, NGI performed a visual crack survey and mapped existing cracks at accessible structure floor and foundation stem wall locations. In addition, NGI completed a 50-foot boring utilizing a sonic drilling technique to assist in determining grouting conditions, prior maximum excavation depths, and fill materials present in the vicinity of secondary clarifier 3. Recommended actions from NGI to mitigate the risk of soil piping and considerations for new structure foundations are presented in Chapter 2.

ES.4 Wastewater Flow and Load Projections

Chapter 3 of the Plan evaluates the historical and projected wastewater flows and loads generated in the City of Wilsonville's service area. The load projections include total suspended solids (TSS), biochemical oxygen demand (BOD₅), ammonia (NH₃), and total phosphorous (TP) loads.

Service area, residential population, industrial contribution, and rainfall records were all considered in the flow and load projection analyses. Facility planning involves estimating rates of growth in wastewater generation within the service area which are unlikely to align precisely with the actual growth observed. During the planning period, City staff will need to assess service area growth at regular intervals and revisit the analysis presented in this Plan.

The City previously estimated population for build-out of their service area. These estimates were taken from the City's Collection System Master Plan (2014, MSA) and as assumed in that document, projected the UGB reaches build-out in 2045. Figure ES.2 details the historical population and growth expected for the City. In addition, the City service area boundary upon which 2045 UGB build-out projections were based on the 2014 CSMP, has been altered slightly to account for a portion of the Basalt Creek Planning Area (BCPA) which is now expected to annex to the City of Tualatin and therefore will not receive wastewater service from the City of Wilsonville. Figure ES.2 illustrates the 2014 UGB build-out population projections from the CSMP compared to those based on the modified service area boundary.

The flow and load projections presented in Chapter 3 are based on the Collection System Master Plan projections (with the slight modification to exclude the portion of the BCPA mentioned above).

A determination will need to be made whether projected flows and loads (which drive assessments of unit process capacity) are aligned with calendar projections presented in this plan and consider if conclusions presented regarding capacity and timing of recommended improvements remain valid. If not, adjustments to the plan will need to be undertaken to ensure sufficient capacity remains available to serve anticipated growth. As actual future wastewater generation rates may also be slightly different than the unit factors considered in this Plan, operations staff at the plant will need to be familiar with the flow and load triggers for planning and design of logical increments of treatment capacity presented in this plan. If growth rates are higher, the schedule for improvements in this plan will need to align with calendar dates presented herein. If growth occurs more slowly, the City will be able to phase WWTP improvements on a less aggressive schedule.

Analysis of flow projections were completed through two different methods: (1) analysis of historical plant records and (2) DEQ Guidelines for Making Wet-Weather and Peak Flow Projections for Sewage Treatment in Western Oregon, which is referred to as the DEQ methodology in this Plan. Since there is no DEQ methodology for load analysis, all projections were developed based on historical plant records. Figure ES.3 summarizes the measured and projected maximum month, peak day and peak hour flows. The projections for the remaining flow elements can be found in Chapter 3. As is shown in Figure ES.3, the peak hour flow is projected to exceed the peak hour flow of 16 mgd listed on the 2014 Improvements Drawings close to the year 2040. The projected 2045 peak hour flow is based on a 10-year (rather than a 5-year) design storm and does not account for storage or flow attenuation in the collection system. In 2023 the City undertook a hydraulic analysis of the WWTP concluding that certain elements will be deficient as the service area develops. This is discussed in greater detail in Chapter 4. This has important implications for facility improvement costs recommended in this Master Plan, which are based on estimates and projections of flows and loads which may not align with the timelines presented in this Master Plan. As such it is recommended the City perform additional evaluation of the WWTP and collection system, along with monitoring actual flows, to further evaluate whether future flow equalization can be achieved and whether recommended improvements at the WWTP will all be triggered within the planning period.

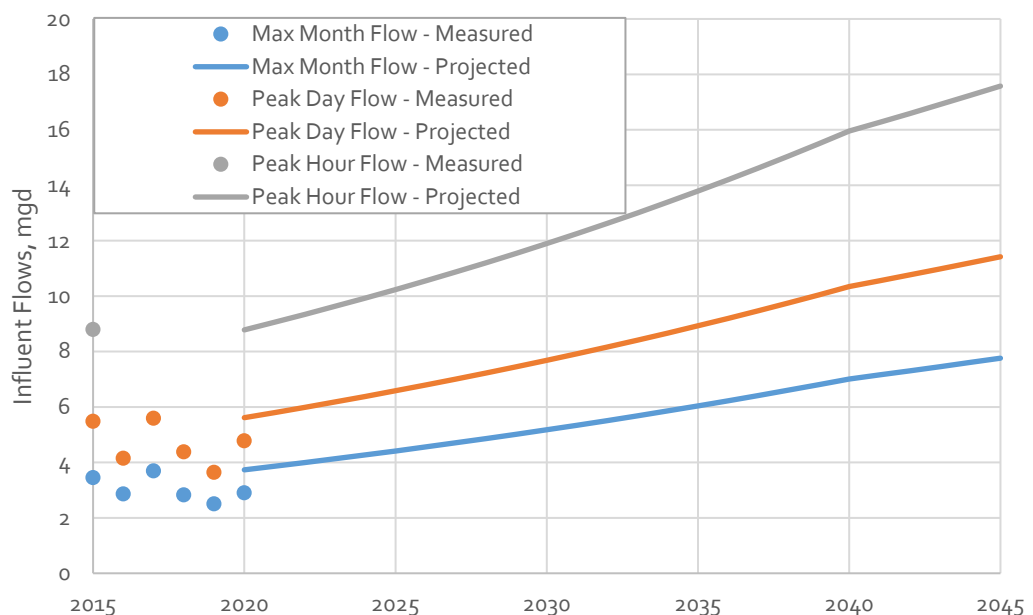

Figure ES.3 Flow Projection Summary

Load projections were calculated for influent TSS, BOD₅, NH₃, and TP. Figure ES.4 summarizes the measured and projected influent maximum month BOD and TSS loads. The projections for the remaining load elements can be found in Chapter 3.

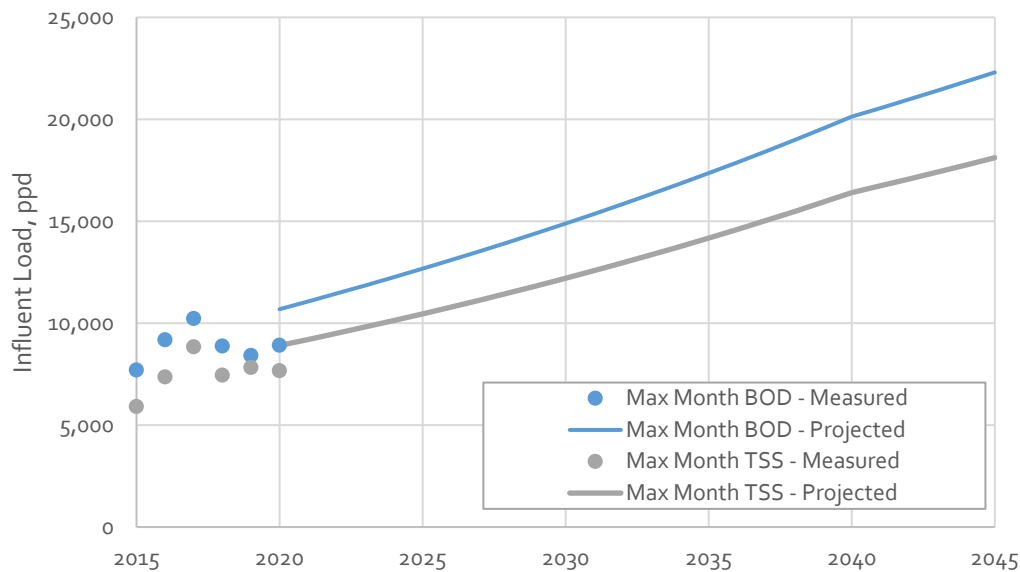

Figure ES.4 Load Projection Summary

The projected flows and loads developed in Chapter 3 were compared against the rated capacity for each of the WWTP's unit processes to determine whether expansion would be required within the planning period. The findings of this capacity analysis are discussed in the next section.

ES.5 Capacity Analysis

Summaries of plant process area capacity assessments and conclusions are presented in this Plan. These assessments focus on the need for improvements or upgrades to existing facilities to address capacity deficiencies identified in the course of Master Plan evaluations. A site plan of the City's existing WWTP is presented in Figure ES.5.

Chapter 4 identifies existing capacity ratings and deficiencies for the liquid and solids stream treatment processes at the City's WWTP. Analyses are based on operational practices in place at the time and existing effluent limits established by the WWTP's NPDES permit. Biological process modeling was performed using BioWin version 6.2 to predict plant performance under current and future flow and loading conditions to assess when unit process capacities may be exceeded within the planning period (present through 2045).

A summary of the capacity assessment completed using growth projections described in Section ES.1 is detailed below in Table ES.2. Chapter 4 presents the methodology and findings in greater detail.



- LEGEND:**
- 1 - DEWATERING & DRYING BUILDING
 - 2 - PROCESS GALLERY
 - 3 - SECONDARY CLARIFIER NO. 1
 - 4 - SECONDARY CLARIFIER NO. 2
 - 5 - UV DISINFECTION SYSTEM
 - 6 - WORKSHOP
 - 7 - SECONDARY PROCESS FACILITY
 - 8 - STABILIZATION BASIN
 - 9 - SLUDGE STORAGE BASINS AND BIOFILTERS
 - 10 - HEADWORKS
 - 11 - DISK FILTERS
 - 12 - COOLING TOWERS
 - 13 - W3 REUSE PUMP STATION
 - 14 - OPERATIONS BUILDING
 - 15 - SITE ENTRANCE

Plot Date: 6/28/2022 9:15:35 AM

FILE NAME: 11962A00_FIGURE_SEED.DWG

LAST SAVED BY: bhawes

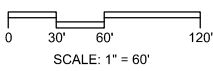

Figure ES.5
EXISTING WILSONVILLE WWTP
 CITY OF WILSONVILLE



Item A.

Table ES.2 Unit Process Capacity Assessment

Unit Process	Capacity Assessment
Preliminary Treatment	
Screening	There is sufficient hydraulic capacity with both mechanical screens operational to accommodate a PHF of 17.6 mgd. Hydraulic modeling conducted by Jacobs in 2023 indicates that hydraulically the influent screening can pass the projected PHF.
Grit Removal	The 2012 WWTP Improvement documents indicate a design capacity of 16 mgd for the vortex grit basin. However, Hydraulic modeling conducted by Jacobs in 2023 indicates that hydraulically, the grit removal system can pass a PHF of 17.6 mgd. At this flow rate the anticipated performance would be poor.
Secondary Treatment	
Secondary Treatment	Based on maximum week MLSS predicted from BioWin modeling at peak day flow with all clarifiers in service (and assuming a 5-day SRT), there is only sufficient capacity through 2027. Upsized process piping is expected to be necessary to convey flow from the headworks to the secondary process and to return activated sludge within the secondary process under future flow conditions
Aeration Blowers	The air demands of the secondary treatment process are projected to exceed the firm capacity of the aeration blowers under peak conditions by 2027.
Tertiary Treatment and Disinfection	
Disk Filters	The existing disk filter capacity is expected to be exceeded by 2032 with one unit out of service or in backwash mode based on effluent limitations included in the City's DBO Contract with Jacobs. At this time the City expects to relax these contract limitations rather than invest in additional capacity.
Secondary Effluent Cooling Towers	The projected peak day flow during the months of June through September is expected to exceed the capacity of the cooling tower by the year 2036.
UV Disinfection	The existing UV channels do not have adequate capacity to disinfect the 2045 PHF with all units in service. However, the firm capacity of the UV system is sufficient to treat the PDDWF through the year 2045 with one channel out of service. The City currently has an older UV unit in place as an emergency backup to the primary system. That backup unit is aging and the City plans replacement during the planning period. By the year 2040, the UV channels are expected to exceed their hydraulic capacity.
Outfall	Even with the Willamette River at its 100-year flood elevation, it is expected that the outfall pipeline can accommodate approximately 19 mgd before the UV channel effluent weirs are at risk of submergence upstream. Since this flow is well above the hydraulic capacity of the rest of the plant, no expansion will be needed until after 2045. ⁽¹⁾ Jacobs found that under projected 2045 PHF conditions certain process and effluent piping, including piping just upstream of the Willamette River outfall and diffuser system, may be hydraulically deficient. At PHF 17.6 mgd and assuming a 0.8 mgd recycle scenario the headworks screens and grit removal systems are expected to be unsubmerged. However, upsized outfall piping between MH-B and MH-D2 is expected to be necessary to convey flow from the headworks to the secondary process under these conditions
Solids Handling	
Gravity Belt Thickener	Assuming continuous operation, the capacity analysis results indicate adequate capacity for thickening the current and projected maximum week WAS loads with one unit out of service. These units are aging and the City plans replacement during the planning period.
TWAS Storage	The TWAS storage volume is sufficient to accommodate the expected maximum week solids loads for two days (assuming TWAS is thickened to 4 percent).
Dewatering Centrifuges	The rated capacity of the current centrifuges is sufficient to process the maximum week load with one unit out of service through 2042 assuming operating times of 24 hours per day for 7 days per week, per the criteria detailed in Chapter 4. ⁽²⁾ These units will reach the end of useful life during the planning period and the City plans replacement accordingly.
Biosolids Dryer and Solids Disposal	The capacity of the biosolids dryer is adequate for handling the current and projected max week solids loads (in year 2045) on the basis of its design evaporation rate, assuming dewatered cake is dried from 20 percent TS to 92 percent TS and the dryer is operated for 24 hour per day for 7 days per week. ⁽³⁾ This unit is aging, has had recent performance issues and the City plans replacement during the planning period.

Notes:

(1) The existing outfall was recently modified and equipped with five parallel diffuser pipes equipped with duckbill check valves to improve the mixing zone characteristics in the Willamette River.

(2) The centrifuges have exhibited inconsistent performance. The City recently refurbished these units and expects they will provide sufficient capacity through 2045.

(3) The existing solids dryer has sufficient capacity through 2045 but has exhibited inconsistent performance.. See Alternative 2B, Chapter 6.

Abbreviations: DBO - Design-Build-Operate; gpd/sf - gallons per day per square foot; MLSS - mixed liquor suspended solids, SPA - State Point Analysis; SRT - solids residence time; TS - total solids; TWAS - thickened waste activated sludge.

Item A.

Table ES.3 further summarizes the capacity assessment by listing each unit process, associated design parameters and year of possible capacity exceedance.

Table ES.3 Unit Process Capacity Year Summary

Unit Process	Design Parameter	Redundancy Criteria	Year of Capacity Exceedance
Influent Screening	PHF	Bypass channel with manual bar rack in service and one mechanical screen out of service	>2045
Grit Chamber	PHF	All units in service	>2045 ⁽¹⁾
Secondary Treatment	MW MLSS Inventory at PDF	All units in service	2027
Secondary Effluent Cooling Towers	June 1 - Sept 30 PDF	All units in service	2036
Disk Filters	MWDWF	One unit in backwash	2032 ⁽²⁾
UV Disinfection Channels	PHF	All units in service	2040 ⁽¹⁾
Outfall	PHF	-	>2045
Gravity Belt Thickening	MW Load	One unit out of service	2042
Dewatering Centrifuges	MW Load	One unit out of service	>2045 ⁽³⁾
Biosolids Dryer	MW Load	All units in service	>2045 ⁽³⁾

Notes:

- (1) The plant hydraulic modeling done as a part of the 2012 WWTP Improvements Project only evaluated plant flows as high as 16 mgd. The projected peak hour flows presented in Chapter 3 exceed this flow by the year 2045. There are some unit processes including the grit removal system, secondary clarification and UV disinfection that have a peak hydraulic capacity of 16 mgd. The hydraulic analysis conducted by Jacobs in 2023 found that under projected 2045 PHF conditions certain process and effluent piping may be hydraulically deficient. At PHF 17.6 mgd and assuming a 0.8 mgd recycle scenario the headworks screens and grit removal systems are expected to be unsubmerged. However, upsized piping is expected to be necessary to convey flow from the headworks to the secondary process under these conditions.
- (2) Existing Disk Filters are predicted to exceed reliable capacity (one unit out of service) in 2028 based on vendor provided design criteria. This conclusion assumes limitations for effluent total suspended solids contained in the WWTP DBO contract, which are far more stringent than the City's NPDES permit. At this time the City expects to relax these contract limitations rather than invest in additional capacity. Following startup of secondary treatment membrane bioreactors in 2030, the tertiary filters will be required less to meet the effluent requirements of the NPDES permit. It is anticipated the City will maintain these facilities to allow flexibility in operation to account for servicing and membrane facility downtime.
- (3) As noted previously, the existing centrifuges and biosolids dryer appear to have sufficient capacity through the planning year 2045, however condition and age are likely to require replacement during the planning period. It is recommended the City reassess available replacement technologies prior to replacement and consider loading appropriate to the planning horizon of any new units selected.

Abbreviations: MW - maximum week

ES.6 Regulatory Considerations and Strategy

It is the responsibility of the Oregon DEQ to establish and enforce water quality standards that ensure the Willamette River's beneficial uses are preserved. Discharges from wastewater treatment plants are regulated through the (NPDES. All discharges of treated wastewater to a receiving stream must comply with the conditions of an NPDES permit. The Wilsonville WWTP discharges to the Willamette River at River Mile 38.5 just upstream of the Interstate 5 bridge. The existing permit limits for the Wilsonville WWTP are shown in Table ES.4. This permit became effective on September 1, 2020 and expires July 30, 2025.

Table ES.4 Current Effluent Permit Limits

Parameter	Average Effluent Concentrations		Monthly Average, (ppd)	Weekly Average, (ppd)	Daily Maximum, (lbs)
	Monthly	Weekly			
May 1 - October 31					
CBOD ₅	10 mg/L	15 mg/L	190	280	380
TSS	10 mg/L	15 mg/L	190	280	380
November 1 - April 30					
BOD ₅	30 mg/L	45 mg/L	560	840	1100
TSS	30 mg/L	45 mg/L	560	840	1100
Other Parameters Limitations					
E. coli Bacteria	<ul style="list-style-type: none"> Shall not exceed 126 organisms per 100 ml monthly geometric mean. No single sample shall exceed 406 organisms per 100 ml. 				
pH	<ul style="list-style-type: none"> Instantaneous limit between a daily minimum of 6.0 and a daily maximum of 9.0 				
BOD ₅ Removal Efficiency	<ul style="list-style-type: none"> Shall not be less than 85% monthly average 				
TSS Removal Efficiency	<ul style="list-style-type: none"> Shall not be less than 85% monthly average 				
ETL June 1 through September 30	<ul style="list-style-type: none"> Option A: 39 million kcal/day 7-day rolling average Option B: Calculate the daily ETL limit 				

Notes:

Abbreviations: CBOD₅ - five-day carbonaceous biochemical oxygen demand; ETL - excess thermal load; kcal/day - kilocalories per day; lbs - pounds, mg/L - milligrams per liter; ml - milliliter.

The WWTP has been compliant with NPDES permit limits, generally. However due to construction issues that required that aeration basins be offline, equipment failure and issues with solids processing, the WWTP did violate their NPDES permit over eight months between 2015 and 2020 (December 2015, February 2017, April 2017, January 2018, August 2018, May 2020, June 2020 and July 2020). Most of these violations were due to the daily effluent TSS load exceeding the maximum daily load limit in the NPDES permit. It is anticipated that once the issues with solids processing are addressed, the City's current treatment process will be able to meet permit limits.

Chapter 5 details potential regulatory issues the City will need to take into consideration in coming years. Several possible regulatory actions by the Oregon DEQ could drive investments in

future improvements at the City's WWTP. The plant discharges to the Willamette River and existing and future effluent limitations contained in the NPDES permit dictate, in large part, the necessary treatment processes and configuration at the WWTP necessary to maintain compliance.

Future treatment upgrades may be required when DEQ establishes total maximum daily loads (TMDL) for the lower Willamette River. Dissolved oxygen and nutrient limits, such as phosphorus limitations, are possible. The dissolved oxygen in the lower part of the river does not always meet water quality standards, and indications of excessive nutrients, such as chlorophyll-a, aquatic weeds, and harmful algal blooms, are present in the lower Willamette River. DEQ has begun its triennial review of Oregon's water quality criteria. The review could result in more stringent or new discharge requirements, but this process will take several years. For planning purposes, providing plant footprint to accommodate future treatment to remove phosphorus and address dry weather seasonal limits on dissolved oxygen should be anticipated. In addition, the City should continue to engage with DEQ regarding any proposed receiving water temperature regulatory actions.

ES.7 Alternative Development and Evaluation

Chapter 6 presents the methodology and findings of a process improvements alternatives evaluation. The plant's treatment process needs were defined by comparing the plant's existing condition, capacity and reliability, with the projected flows, loads, and regulatory constraints for the recommended alternatives. Where capacity deficiencies were predicted, at least two alternatives were analyzed for each corresponding unit process. Process modifications associated with each alternative were modeled in BioWin to evaluate the overall impact on plant operations.

As identified in Chapter 4, the secondary treatment process is expected to require additional capacity during the planning horizon (2045). Chapter 6 details two alternatives to address these capacity limitations. The two alternatives considered to increase secondary capacity are:

1. Expansion of the existing conventional activated sludge process; and
2. Intensification of the existing treatment process using membrane bioreactor (MBR) technology.

Due to the higher capital and operating costs of intensification, construction of a new conventional aeration basin is recommended as the first phase to increase secondary capacity. As flows and loads increase, or regulatory requirements become more stringent, it is expected to become necessary to intensify treatment. It is recommended the City revisit this evaluation as the need for 1) additional capacity to accommodate growth nears or 2) more stringent effluent limitations are considered. This offers the opportunity to take advantage of potential advances in technology as well as confirming the predicted time frame of capacity exceedance. A new aeration basin project is included in the Capital Improvement Plan in Chapter 7. As loads continue to increase, this plan includes the gradual conversion of the existing conventional activated sludge process to a membrane bioreactor process.

The existing aeration blower system firm capacity is expected to be deficient by 2027. An additional aeration blower (with approximately double the capacity of the current blowers) would provide for the first phase of capacity expansion. As loads continue to increase, the plan includes the gradual upsizing of the existing blowers.

The projected peak day flow between June through September is expected to exceed the capacity of the existing cooling tower. Since the existing cooling tower system was designed to be expanded with the addition of one more tower, the plan assumes the expansion of the existing cooling tower process by the year 2036 to meet the projected summer peak day flows.

Additional tertiary filtration capacity is predicted to be needed by 2032 to provide full treatment of the MWDWF with one disc filter out of service or in backwash mode. As the City has selected an intensification technology utilizing membranes, this is likely to eliminate tertiary filtration capacity concerns as the membranes replace the filtration process for TSS removal in plant effluent.

While the capacity assessment findings presented in Chapter 4 determined existing gravity belt thickeners and dewatering centrifuges have sufficient capacity assuming continuous operation, the remaining equipment service life may require replacement within the planning horizon. The centrifuges, installed in 2014, were recently refurbished, but by 2045, will have been in service for over 30 years. In addition, the gravity belt thickeners (GBT) which thicken the sludge prior to delivery to the centrifuges for dewatering, have been in service even longer. The City should plan for their replacement within the planning horizon and consider whether a capacity increase is needed at the time of replacement based on projections of solids production and processing needs. Additionally, the secondary process was modified in 2020 and has experienced extended periods where mixed liquor concentrations have been elevated above typical ranges for conventional activated sludge or extended aeration processes. Due to the complications with secondary process operation and performance issues with the centrifuges, it is recommended the City study the secondary treatment and dewatering processes to confirm that the assumptions and conclusions regarding centrifuge capacity in Chapter 4 may be relied upon. A dewatering performance optimization study is recommended so the City can collect and analyze secondary treatment and solids processing performance data. For budgeting purposes, an opinion of probable cost for replacing the existing centrifuges is presented in Chapter 7. Timing of that equipment replacement will depend on performance of the existing units, future loading assumptions, and observed condition.

The existing solids dryer has experienced operational issues in recent years, including a fire that caused extensive damage to the equipment in April 2019 and a leaking rotary joint and damaged seal in 2021. As of February 25, 2022, the dryer has been repaired and is operating. Because of the City's commitment to solids drying as the preferred process to achieve Class A biosolids, the alternatives evaluation presented in this Plan for future dryer replacement was conducted with a focus on thermal drying options only.

Chapter 6 details an analysis of the following alternatives to improve the drying system:

1. Alternative 1 - Continue operating the existing biochemical reactor (BCR) paddle dryer and defer replacement.
2. Alternative 2 - Modify the existing Dewatering and Drying Building to accommodate a different solids dryer technology or a redundant dryer.
3. Alternative 3 - Construct a new dryer building with a different solids dryer technology.

While it is anticipated the existing dryer has useful life through at least 2026 (current DBO contract expiration), by 2031 the dryer will have been in operation for over 15 years. It is recommended the planning and design of upgrades to provide reliable dryer capacity begin in 2031, or sooner if further operational concerns arise. The City has indicated a preference for a

variation of Alternative 2 which involves expanding the existing Dewatering and Drying Building to accommodate a second solids paddle dryer. This alternative provides backup capacity to allow the City to continue delivering Class A solids during periods of downtime if a mechanical failure occurs or to accommodate regular maintenance of one dryer train. As mentioned previously, this Plan recommends the City complete a study of the secondary sludge quality, performance of that process, chemical addition types and locations, and solids handling process performance overall prior to making a final selection of the preferred dryer alternative from the alternatives detailed in Chapter 6. For purposes of capital planning, this Plan assumes the City will implement Alternative 2b (modification of Dewatering and Drying Building to accommodate a second paddle dryer) with a study and confirmation of this selection beginning in 2031.

Lastly, the City wants to establish a direct connection between the City's fiber optics network and the WWTP. This addition consists of routing two new conduits (one spare) and fiber optic cabling from the WWTP's Operations Building to the site entrance, where the conduits will be tied into the City's fiber optics network. Chapter 6 details one potential routing from the Operations Building to the site entrance that would minimize impact to existing yard utilities. The fiber optic cable addition is included in Chapter 7 and the City's 5-year CIP.

Table ES.5 below summarizes the alternatives evaluated in Chapter 6 including recommendations for future WWTP improvements.

Table ES.5 Summary of Alternatives

Unit Process	Alternatives Considered	Selected Alternative
Secondary Treatment	<ul style="list-style-type: none"> Expansion of the existing conventional activated sludge process. Intensification of the existing treatment process. 	<ul style="list-style-type: none"> Expansion of the existing conventional activated sludge process through the addition of another aeration basin. Further phased expansion of capacity through addition of membrane bioreactor (MBR) and fine screening facilities.
Solids Dryer	<ul style="list-style-type: none"> Continue operating the existing BCR paddle dryer and defer replacements. Modify the existing Dewatering and Drying Building to accommodate a different solids dryer technology or a redundant dryer. Construct a new dryer building with a different solids dryer technology. 	<ul style="list-style-type: none"> Modify the existing Dewatering and Drying Building to accommodate a different solids dryer technology or a redundant dryer by expanding the Dewatering and Drying Building to accommodate a second solids paddle dryer.

ES.8 Recommended Alternative

Figure ES.6 presents a WWTP site plan identifying locations of recommended improvements resulting from condition and capacity assessments, including evaluation of alternatives, as described.

Summaries of opinions of probable costs and anticipated phasing for the improvements recommended for inclusion in the City's WWTP CIP are provided in Table ES.6.

The expected cash flow for the planning period was determined for the recommended improvements summarized in Table ES.6. The cash flow through 2045 includes an escalation rate of three percent, and the estimated peak expenditure for any fiscal year is

approximately \$55,434,000 in fiscal year 2030. The projected CIP expenditures are presented in Figure ES.7. Capital costs estimated in the Plan will be considered as the City assesses the need to adjust sewer enterprise rates and charges in coming months. It will be important to distinguish capacity and condition (repair and replacement) driven improvements in assigning costs to existing rate payers and future users.

Table ES.6 WWTP CIP - Recommended Alternative Opinion of Probable Cost and Phasing

Plant Area	Project ⁽¹⁾	Opinion of Probable Cost ⁽²⁾	Approximate Year Online
Solids Handling	Dewatering Performance Optimization	\$150,000	2025
Communications/IT	Fiber Optic Cable Addition	\$60,000	2025
UV System	Backup UV System Improvement	\$1,705,000	2026
Support Buildings	Seismic Improvements	\$1,082,000	2026
Secondary Treatment	New Conventional Aeration Basin and Blower	\$10,222,000	2027 ⁽³⁾
Secondary Treatment	New Secondary Clarifier Mechanisms	\$1,775,000	2027
Secondary Treatment	New MBR, Blowers and Fine Screens (Phase 1)	\$69,727,000	2031
Solids Handling	Solids Dryer Improvement	\$17,130,000 ⁽⁷⁾	2033
Solids Handling	Existing Centrifuge and GBT Replacement	\$3,701,000 ^(4,6)	2033 ⁽⁵⁾
Cooling Towers	New Effluent Cooling Tower	\$642,000	2036
Secondary Treatment	Additional MBR and Blower Capacity (Phase 2)	\$2,330,000	2039
UV System	UV Equipment Replacement	\$2,571,000	2040
Outfall	Outfall Improvements	\$1,244,000	2040
Secondary Treatment	Additional MBR and Blower Capacity (Phase 3)	\$8,117,000	2044
TOTAL		\$120,456,000	

Notes:

White rows indicate projects that are in the City's 5-year CIP and blue rows indicate projects that are outside the 5-year CIP window.

- (1) Details of each project can be found in Chapter 2 or Chapter 6 of this Master Plan.
- (2) The estimated opinion of probable costs include the construction costs plus ELA (or soft costs). Details on the estimated project costs can be found in Chapter 2 or Chapter 6 of the plan, with the exception of costs for the backup UV system and centrifuges which are presented earlier in Chapter 7. All costs presented are based on an August 2023 ENR index of 13473.
- (3) As identified in Chapter 4, the secondary treatment process at the Wilsonville WWTP is expected to require additional capacity by the year 2027. Since design and construction of a new aeration basin may take longer than the year 2027, the City will likely need to operate at SRTs lower than 5 days during the maximum week condition if growth occurs as predicted in Chapter 3.
- (4) For budgeting purposes, the Option B centrifuge cost from Table H-2 in Appendix H is used for the project cost summary and the CIP.
- (5) Replacement timing dependent upon satisfactory equipment performance.
- (6) The centrifuges installed with the City's 2014 upgrade project have exhibited inconsistent performance in recent months. The City recently refurbished these units and expects they will provide sufficient capacity through 2042. However, by that time, the units will have been in service for over 30 years. It is recommended the City plan for replacement of these units during the planning horizon of this Master Plan. Assuming replacement occurs in the mid-2030's the City should reassess capacity needs of those units beyond the 2045 horizon, consistent with the expected service life of the new equipment.
- (7) The existing solids dryer has sufficient capacity through 2045. As with the dewatering centrifuges, the dryer equipment will soon have been in operation for a decade. It is recommended the City plan for replacement of the dryer during the planning horizon of this Master Plan. The City plans to replace the existing dryer with a new piece of equipment using similar technology and potentially rehabilitate the existing unit to serve as a backup. See Alternative 2B, Chapter 6.

The years in which key processes are projected to exceed capacity are presented in Figure ES.8. The green line illustrates projected MM BOD triggers for existing and proposed new secondary treatment facilities. Projected PHF is shown in blue indicating capacity exceedance of the cooling tower and certain elements of plant hydraulics. Prior to the year of projected exceedance, planning, design, and construction activities will be required to allow upgrades to be commissioned to prevent capacity exceedances. It is important to note that the timing of improvements should be driven by the rate of growth in influent flow and load. Dates indicated in Figure ES.8 and elsewhere in this document should be considered best, conservative estimates based on projections presented herein and professional judgment.

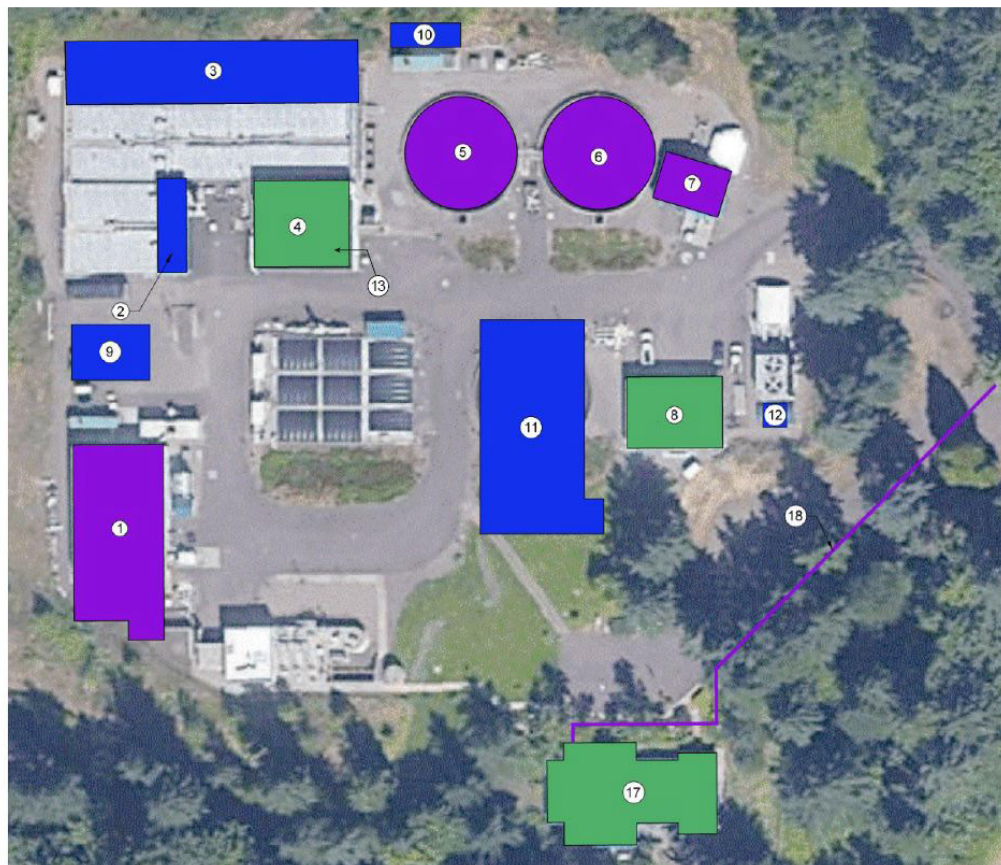

- 3** New Aeration Basin
- 2** Additional Aeration Blowers
- 9** New Fine Screens
- 10** New Emergency Generator
- 11** New MBR Facility
- 12** New Cooling Tower
- 13** Replace Gravity Belt Thickeners
- 7** Replace backup UV system
- 1** Replace Solids Dryer & Centrifuges
- 5** **6** Replace Clarifier 1 & 2 mechanisms
- 4** **8** **17** Seismic retrofits of buildings
- 18** New fiber optic connection
- Solids process study

Figure ES.6 Proposed WWTP Improvements Site Plan

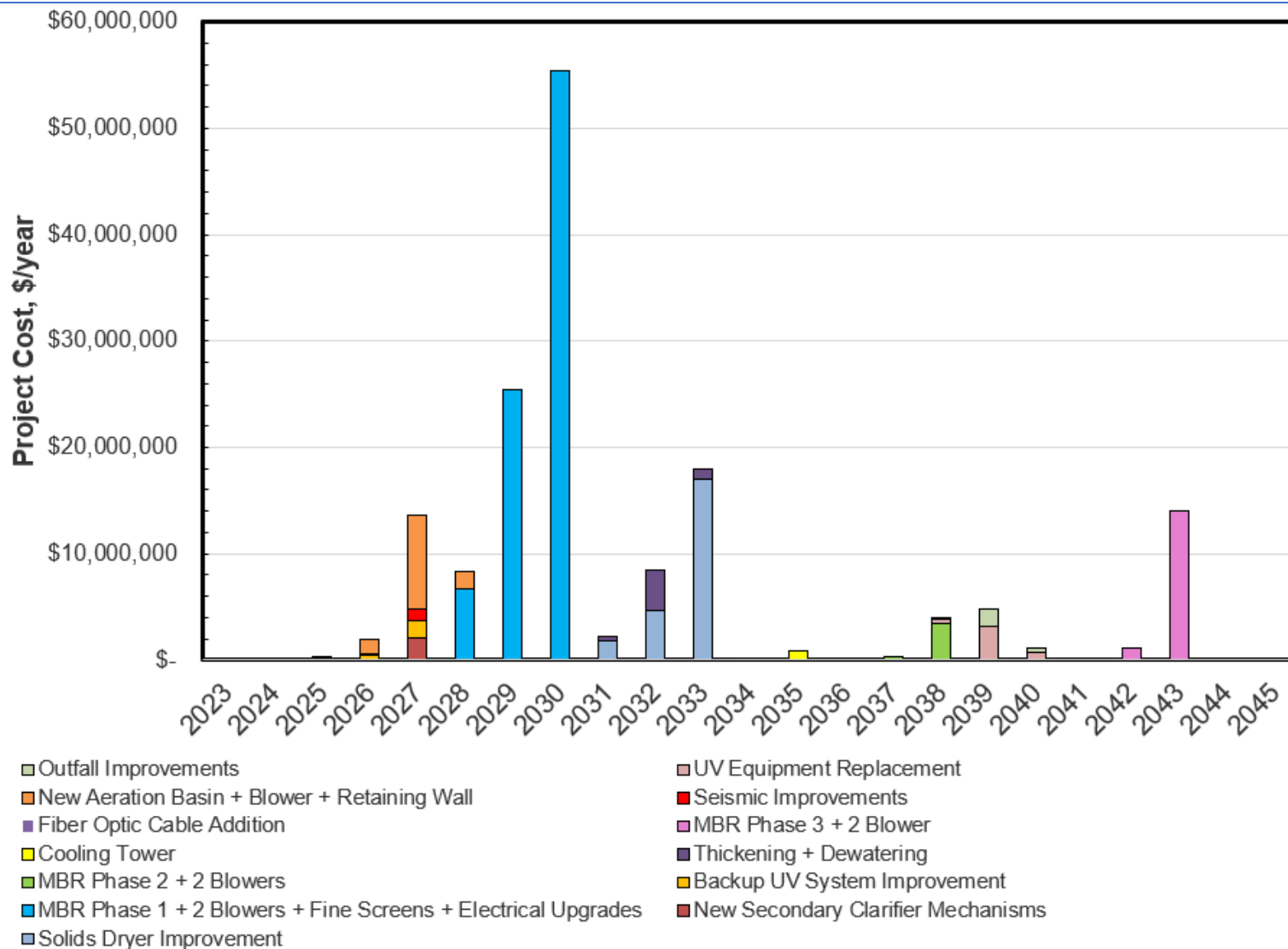

Figure ES.7 Projected 20-Year CIP Expenditures

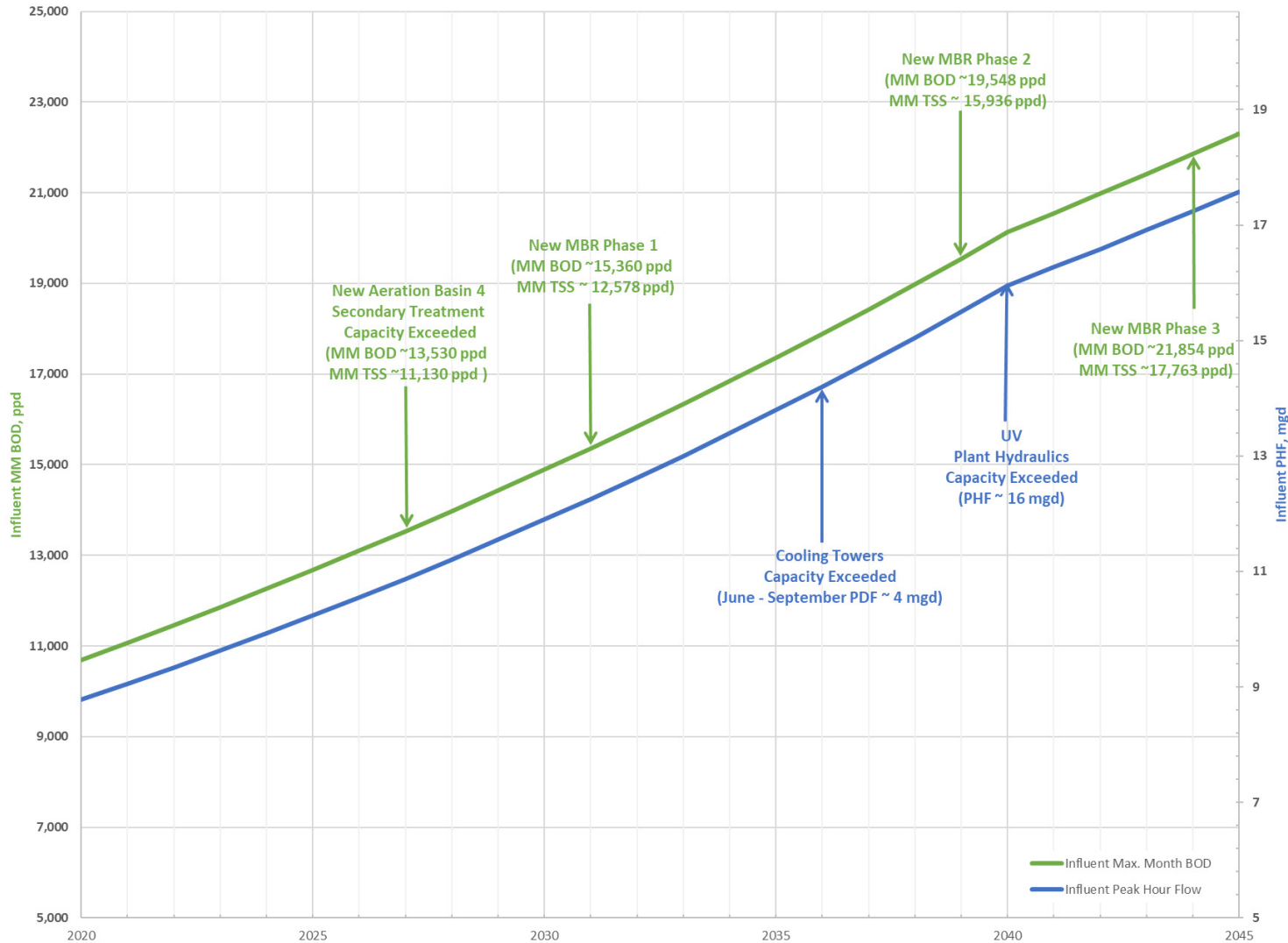

Figure ES.8 Capacity Trigger Graph

City of Wilsonville Wastewater Treatment Plant Master Plan

City Council Work Session

November 6, 2023



Project Overview and Update



- Work Completed Since Last Work Session
 - Updated population growth projections and service area boundary
 - Increased existing industrial discharges to maximum allowed by permit limits
 - Expanded seismic resilience analysis
 - Hydraulic modeling of WWTP
 - Updated capital project list and schedule

Capital Planning and Expected Growth - 2045

- Buildout of Service Area through 2045
 - Adjusted population growth rate, consistent with recent planning efforts
 - Modified service area boundary, per Basalt Creek Concept Plan

Buildout Population Projections (High 2.9%)

2020	2030	2045	2050
25,915	35,163	46,798	50,388

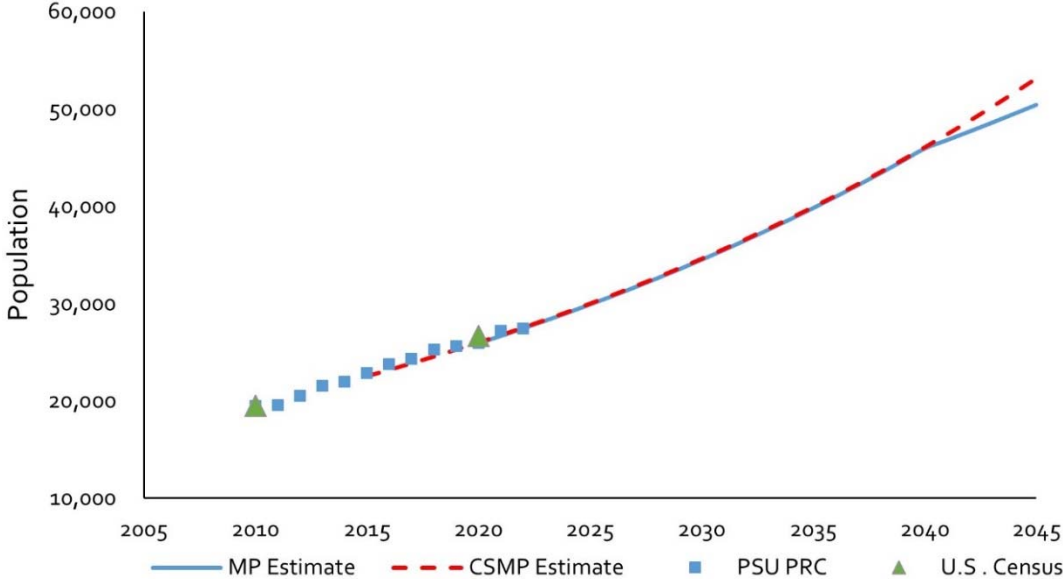

Facility Capacity Assessment



- Flows & Loads Updated to reflect Buildout of Service Area
- Projected 2045 flows and loads exceed design criteria (~2X current)

Item	2022	Rated Capacity	Projected 2045
Average Dry Weather Flow, mgd	2.06	4.00	4.17
Average Annual Flow, mgd	2.39	4.48	4.77
Maximum Month Wet Weather Flow, mgd	4.00	6.68	7.76
Max Month BOD ₅ , ppd	11,456	12,900	22,301
Max Month TSS, ppd	9,504	12,500	18,116

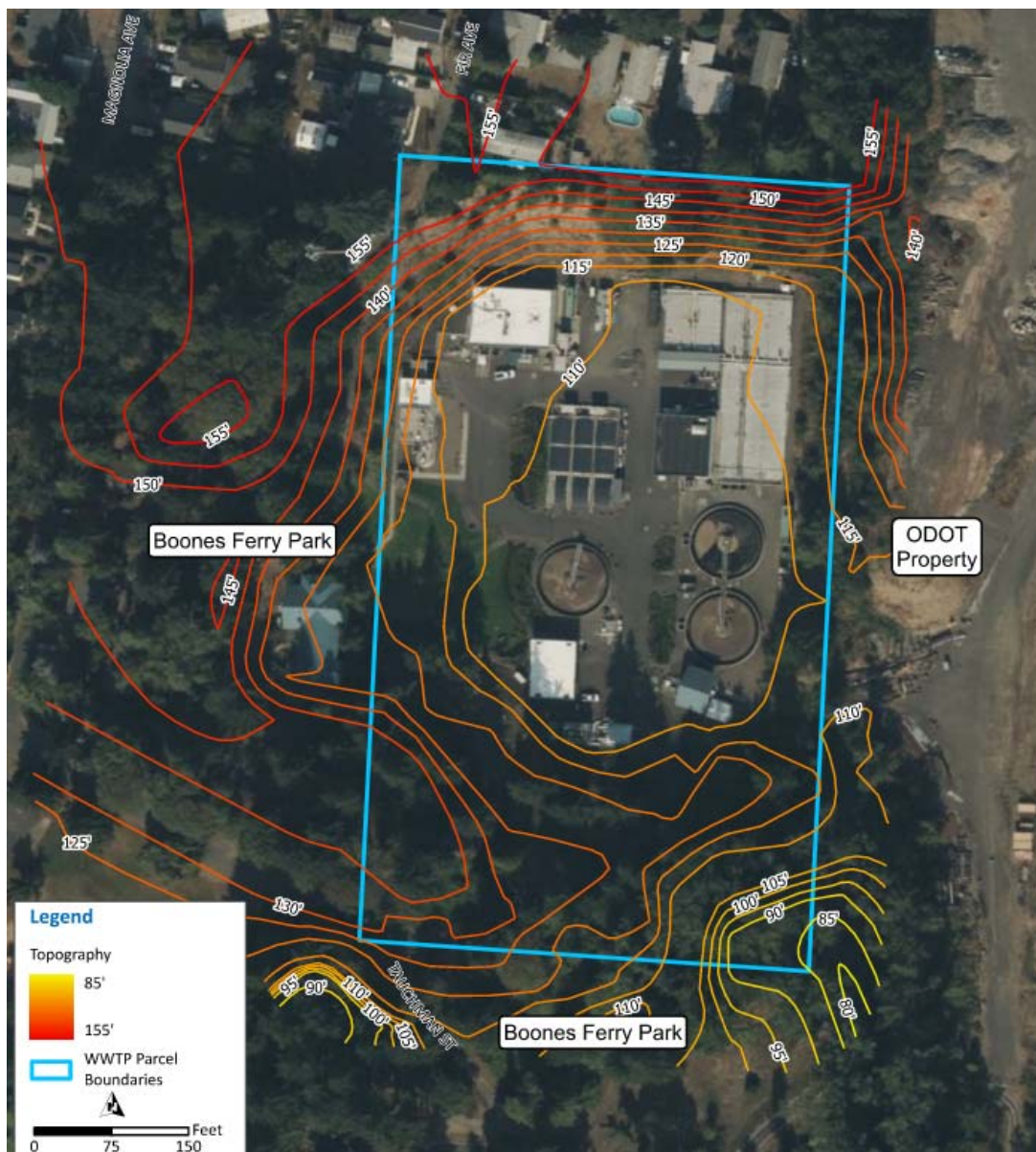

Existing Vicinity Map



Selection of MBR Process

Alternative	Advantages	Challenges
Membranes (Selected)	<ul style="list-style-type: none"> Space-efficient High-quality effluent Provides capacity for reliable full nitrification No need to expand tertiary filtration 	<ul style="list-style-type: none"> Expensive (>2x cost of 4th AB) Requires Fine Screening High O&M Costs (Power, Chemicals, etc.) Highest aeration rate Redundancy requirements
BioMag[®]	<ul style="list-style-type: none"> Space-efficient High-quality effluent Potentially no need to expand tertiary filtration Utilizes secondary clarifier capacity (no stranded assets) 	<ul style="list-style-type: none"> Requires Magnetite Recovery Facility Increased maintenance requirement from the magnetite Reports of solids smoldering, may require inert gas system Will not provide sufficient capacity under projected 2045 F&L
IFAS	<ul style="list-style-type: none"> Space-efficient Utilizes secondary clarifier capacity (no stranded assets) 	<ul style="list-style-type: none"> Will not provide sufficient capacity under projected 2045 F&L Significant basin modifications needed



Recommended Plan

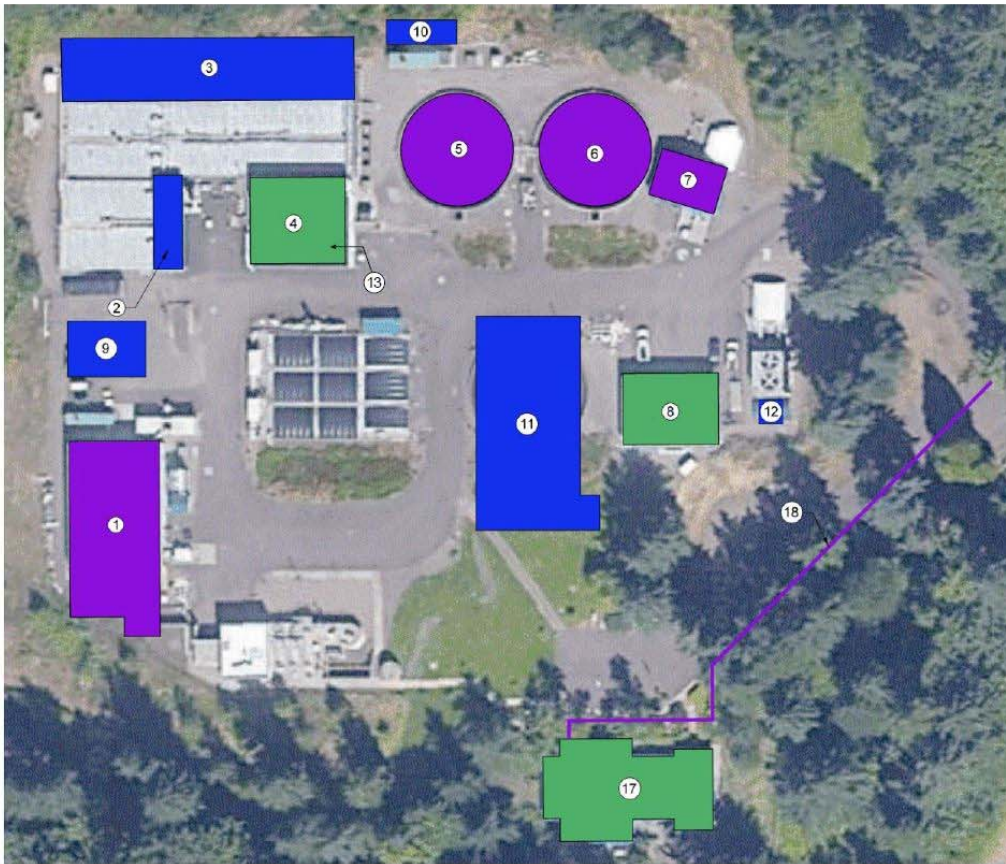

- ③ New Aeration Basin
- ② Additional Aeration Blowers
- ⑨ New Fine Screens
- ⑩ New Emergency Generator
- ⑪ New MBR Facility
- ⑫ New Cooling Tower
- ⑬ Replace Gravity Belt Thickeners
- ⑦ Replace backup UV system
- ① Replace Solids Dryer & Centrifuges
- ⑤ ⑥ Replace Clarifier 1 & 2 mechanisms
- ④ ⑧ ⑰ Seismic retrofits of buildings
- ⑱ New fiber optic connection
- ⑲ Solids process study

Project Cost

DESCRIPTION	ESTIMATED TIMEFRAME	AUGUST 2023 PROJECT COST
Dewatering Performance Optimization	2025	\$150,000
Fiber Optic Cable Addition	2025	\$60,000
Backup UV System Replacement	2026	\$1,705,000
Seismic Improvements	2026	\$1,082,000
New Aeration Basin + Blower + Retaining Wall	2025 – 2027	\$10,222,000
Replace Secondary Clarifier Mechanisms	2026 – 2027	\$1,775,000
MBR Phase 1 + 2 Blowers + Fine Screens + Electrical Upgrades	2028 – 2030	\$69,727,000
Solids Dryer Addition	2031 – 2033	\$17,130,000
Thickening + Dewatering	2031 – 2033	\$3,701,000
Additional Cooling Tower	2034 – 2035	\$642,000
MBR Phase 2 + 2 Blowers	2037 – 2038	\$2,330,000
UV Equipment Replacement	2039 – 2040	\$2,571,000
Outfall Improvements	2039 – 2040	\$1,244,000
MBR Phase 3 + 2 Blowers	2042 – 2043	\$8,117,000
TOTAL		\$120,456,000



Capacity Trigger Plot

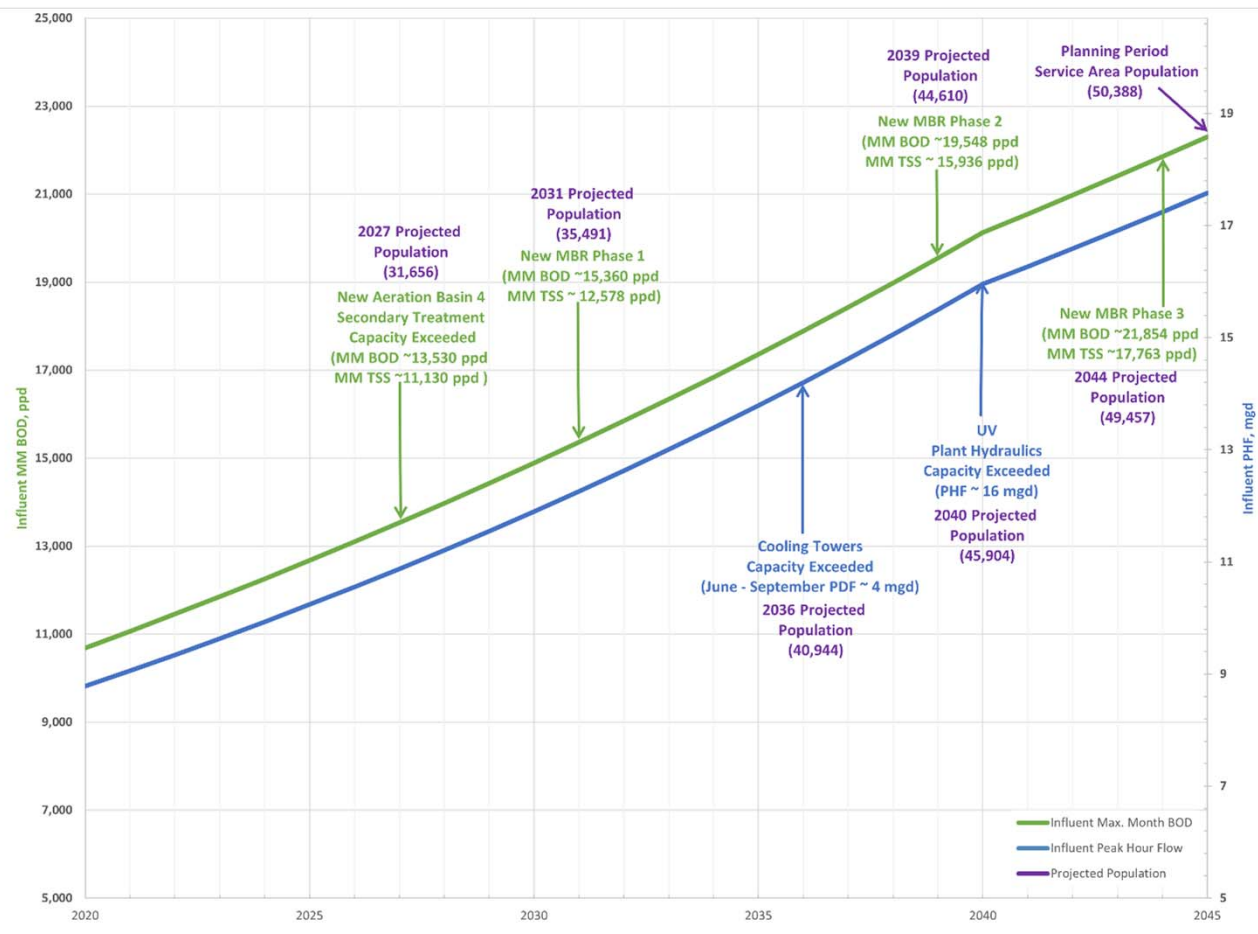

Next Steps



- Planning Commission Public Hearing 12/13/23
- City Council Public Hearing 1st Reading 1/4/24
- City Council 2nd Reading 1/18/24
- Sewer System Rate Study and SDC Update 2024

Questions?

City Council Meeting Action Minutes November 6, 2023

COUNCILORS PRESENT

Mayor Fitzgerald
 Council President Akervall – Arrived 7:00 p.m.
 Councilor Linville
 Councilor Berry
 Councilor Dunwell – Arrived 5:07 p.m.

Erika Valentine, Arts & Culture Program Coordinator
 Jeanna Troha, Assistant City Manager
 Kerry Rappold, Natural Resources Manager
 Kimberly Veliz, City Recorder
 Kris Ammerman, Parks and Recreation Director
 Mark Ottenad, Public/Government Affairs Director
 Mike Nacrelli, Civil Engineer
 Stephanie Davidson, Assistant City Attorney
 Zach Weigel, City Engineer
 Zack Morse, Parks Maintenance Specialist
 Zoe Mombert, Assistant to the City Manager

STAFF PRESENT

Bryan Cosgrove, City Manager
 Amanda Guile-Hinman, City Attorney
 Dan Pauly, Planning Manager
 Delora Kerber, Public Works Director
 Dustin Schull, Parks Supervisor

AGENDA ITEM	ACTIONS
WORK SESSION	START: 5:06 p.m.
A. Wastewater Treatment Plant Master Plan Update	Staff shared analysis that informs an updated draft of the Wastewater Treatment Plant Master Plan.
B. Stormwater Master Plan Update – Executive Summary and Capital Improvement Project	Staff presented an executive summary of the draft Stormwater Master Plan, a 20-year plan detailing the City’s work plan and identifying capital needs to effectively maintain, restore and enhance local watersheds and to meet engineering, environmental and land use needs.
C. Frog Pond East and South Development Code	Staff sought the Council’s feedback to inform development code amendments drafted for the Frog Pond East and South Master Plan.
D. Boones Ferry Park Projects Update	Staff provided a combined presentation on Resolution Nos. 3088 and 3089, both of which provide upgrades to Boones Ferry Park.
REGULAR MEETING	
<u>Mayor’s Business</u>	
A. Upcoming Meetings	Upcoming meetings were announced by the Mayor as well as the regional meetings she attended on behalf of the City.

<p>B. Proclamation</p>	<p>The Mayor read a proclamation declaring November 2023 as National American Indian Heritage month.</p>
<p><u>Communications</u></p> <p>A. None.</p>	
<p><u>Consent Agenda</u></p> <p>A. <u>Resolution No. 3088</u> A Resolution Of The City Of Wilsonville Approving A Construction Contract With Romtec, Inc. For The Boones Ferry Restroom Construction Project.</p> <p>B. <u>Resolution No. 3089</u> A Resolution Of The City Of Wilsonville Approving A Construction Contract With Buell Recreation LLC For The Boones Ferry Playground Project.</p> <p>C. <u>Resolution No. 3090</u> A Resolution Of The City Of Wilsonville Authorizing The City Manager To Execute A Master Services Agreement With OpenGov, Inc. For Asset Management Software Services.</p> <p>D. <u>Resolution No. 3092</u> A Resolution Of The City Of Wilsonville Authorizing The City Manager To Execute A Professional Services Agreement With Century West Engineering For Engineering Consulting Services For The 2024 Street Maintenance Project (Capital Improvement Project No. 4014, 4118, 4725).</p> <p>E. <u>Resolution No. 3093</u> A Resolution Of The City Of Wilsonville Accepting The Jurisdictional Surrender For A Portion Of SW Stafford Road And SW Frog Pond Lane By Clackamas County Pursuant To Oregon Revised Statute 373.270.</p> <p>F. Minutes of the October 16, 2023 City Council Meeting.</p>	<p>The Consent Agenda was adopted 5-0.</p>
<p><u>New Business</u></p> <p>A. <u>Resolution No. 3081</u> A Resolution Of The City Of Wilsonville Approving The City Of Wilsonville Public Art Policy And Guidelines.</p>	

<p>B. <u>Resolution No. 3083</u> A Resolution Of The City Of Wilsonville Adopting The Arts, Culture, And Heritage Commission (ACHC) FY 2023/24 Five-Year Action Plan And Annual One-Year Implementation Plan.</p> <p>C. <u>Resolution No. 3091</u> A Resolution Of The City Of Wilsonville Adopting The Findings And Recommendations Of The “Solid Waste Collection Rate Report, October 2023” And Modifying The Current Republic Services Rate Schedule For Collection And Disposal Of Solid Waste, Recyclables, Organic Materials And Other Materials, Effective January 1, 2024.</p>	<p>Resolution No. 3083 was adopted 5-0.</p> <p>Resolution No. 3091 was tabled until the December 4, 2023 City Council meeting.</p>
<p><u>Continuing Business</u></p> <p>A. None.</p>	
<p><u>Public Hearing</u></p> <p>A. <u>Ordinance No. 883</u> An Ordinance Of The City Of Wilsonville Adopting A Franchise Agreement For Solid Waste Management And Collection Within The City And Repealing Ordinance No. 814.</p>	<p>After a public hearing was conducted, Ordinance No. 883 was adopted on first and second reading by a vote of 5-0.</p>
<p><u>City Manager’s Business</u></p>	<p>The City Manager shared staff would arrange a training for Council to prepare them for their trip to Kitakata, Japan.</p>
<p><u>Legal Business</u></p>	<p>The City Attorney, who is also a running coach at the Coffee Creek Correctional Facility, shared some feedback from adults in custody who participate in the running program.</p>
<p>ADJOURN</p>	<p>10:10 p.m.</p>



PLANNING COMMISSION

WEDNESDAY, OCTOBER 11, 2023

WORK SESSION

4. Wastewater Treatment Plant Master Plan (Nacrelli) (15 minutes)



PLANNING COMMISSION WORK SESSION STAFF REPORT

Meeting Date: October 11, 2023		Subject: Wastewater Treatment Plant Master Plan	
		Staff Member: Mike Nacrelli, Senior Civil Engineer	
		Department: Community Development	
Action Required		Advisory Board/Commission Recommendation	
<input type="checkbox"/> Motion <input type="checkbox"/> Public Hearing Date: <input type="checkbox"/> Ordinance 1 st Reading Date: <input type="checkbox"/> Ordinance 2 nd Reading Date: <input type="checkbox"/> Resolution <input checked="" type="checkbox"/> Information or Direction <input type="checkbox"/> Information Only <input type="checkbox"/> Council Direction <input type="checkbox"/> Consent Agenda		<input type="checkbox"/> Approval <input type="checkbox"/> Denial <input type="checkbox"/> None Forwarded <input checked="" type="checkbox"/> Not Applicable	
		Comments: N/A	
Staff Recommendation: Provide requested input regarding recommended capital improvement plan.			
Recommended Language for Motion: N/A			
Project / Issue Relates To:			
<input checked="" type="checkbox"/> Council Goals/Priorities: Align Infrastructure Plans with Sustainable Financing Sources	<input type="checkbox"/> Adopted Master Plan(s):	<input type="checkbox"/> Not Applicable	

ISSUE BEFORE PLANNING COMMISSION:

Provide feedback and input on components of the Wastewater Treatment Plant (WWTP) Master Plan.

EXECUTIVE SUMMARY:

This new City of Wilsonville (City) Wastewater Treatment Plant (WWTP) Master Plan (the Plan) has been developed to satisfy requirements associated with the State of Oregon Department of Environmental Quality (DEQ) guidance document entitled “Preparing Wastewater Planning Documents and Environmental Reports for Public Utilities.” To accommodate future flows and loads, projections were developed based on population projections and referencing WWTP historical data and DEQ wet weather project methodologies. Similarly, to accommodate future water quality regulations, the Plan is adaptive and considers potential future regulatory changes.

The City prepared the Plan with the goal of developing a capital plan that identifies improvements required through the planning period (today through 2045) to comply with requirements of the WWTP National Pollutant Discharge Elimination System (NPDES) permit and potential future regulatory requirements, while accommodating growth identified in the City of Wilsonville Comprehensive Plan (October 2018, updated June 2020 - the 2018 Comprehensive Plan). These improvements are designed to provide the best value to the City’s ratepayers by maximizing the use of existing infrastructure and improving system operation while continuing to protect water quality and human health and supporting economic development, consistent with goals and policies contained in the 2018 Comprehensive Plan and 2021-2023 City Council Goals.

The City’s WWTP was originally built in 1971 and discharges treated effluent to the Willamette River. The WWTP underwent major upgrades in 2014 to expand the average dry weather capacity to four million gallons per day (mgd) to accommodate the City’s continued growth. The WWTP processes include headworks screening and grit removal facilities, aeration basins, stabilization basins, secondary clarifiers, biosolids processing, cloth filtration, and disinfection processes. Additionally, the City contracts with Jacobs for operation of the wastewater treatment plant, located at 9275 Southwest Tauchman Road.

This Plan identifies improvements taking into consideration:

- The age and condition of existing process equipment and structures,
- Growth in demand for sewer service due to increased population and economic development over the planning period,
- Potential changes to water quality regulations impacting process needs in order to meet effluent limitations and discharge prohibitions imposed by the Oregon Department of Environmental Quality (DEQ), and
- Consistency with the 2018 Comprehensive Plan and City Council 2021-2023 Goals 5, 6, & 7.

Updated Growth Projection and Capital Improvement Plan

At the previous work session (9/14/2022), the team presented the capital improvement plan based on an assumed 2.9% annual population increase, consistent with recent planning documents adopted by the City, including the Wastewater Collection System Master Plan (CSMP, November 2014) and the Willamette River Water Treatment Plan Master Plan Update

(March 2018). The flow and load projections have been further updated to account for increases in industrial discharges, as allowed under existing permits. This change results in a higher level of capital investment over the planning period, mainly due to hydraulic upgrades, as reflected in the table below.

Project Description	Timeframe	Cost*
Dewatering Performance Optimization	2025	\$150,000
Fiber Optic Conduit Addition	2025	\$60,000
UV System Improvement	2026	\$1,705,000
Seismic Improvements	2026	\$1,082,000
New Aeration Basin and Blower	2025 – 2027	\$10,179,000
Replace Secondary Clarifier Mechanisms	2026 - 2027	\$1,775,000
Membrane Bioreactor (MBR) Phase 1 (includes new blower, fine screens, electrical and hydraulic upgrades)	2028 – 2030	\$69,637,000
New Solids Dryer	2031 – 2033	\$17,130,000
Thickening and Dewatering Improvements	2031 – 2033	\$3,701,000
New Cooling Tower	2037 – 2038	\$642,000
MBR Phase 2 (includes new blower)	2037 – 2038	\$2,242,000
UV Equipment Replacement and Outfall Upsizing	2039 – 2040	\$2,571,000
UV Equipment Replacement and Outfall Upsizing	2039 – 2040	\$1,244,000
MBR Phase 3 (includes 2 new blowers)	2042 – 2043	\$8,030,000
Total		\$120,148,000
*Costs are shown in 2023 dollars and include 25% for engineering, legal, and administration.		

As shown in the table above, the most significant impact to the required level of capital investment is the need for membrane bioreactor (MBR) facilities. These are state-of-the-art, compact facilities that provide a high level of treatment. The adjusted growth projection results in an approximate doubling of the City population over the planning period. Due to the limited amount of space available at the existing WWTP site, MBR facilities are the only feasible means of providing the necessary treatment to accommodate such a substantial rate of growth.

Question for the Planning Commission:

What input does the Planning Commission have on the updated capital improvements list for the Wastewater Treatment Plant Master Plan?

EXPECTED RESULTS:

The Plan includes a list of recommended capital improvements, along with an anticipated schedule for completion and preliminary cost estimates. These improvements will provide the basis for an analysis of sewer rates and system development charges (SDCs) that will be necessary to provide adequate funding to implement to required upgrades.

TIMELINE:

This is the third in a series of presentations to the Planning Commission and City Council. Completed and planned meetings are as follows:

- Planning Commission Work Session 7/13/22 (completed)

- City Council Work Session 8/1/22 (completed)
- Planning Commission Work Session 9/14/22 (completed)
- Planning Commission Work Session 10/11/23 (current)
- City Council Work Session 11/6/23
- Planning Commission Public Hearing 12/13/23
- City Council Public Hearing 1st Reading 1/4/24
- City Council 2nd Reading 1/18/24

CURRENT YEAR BUDGET IMPACTS:

The remaining contract balance for finalizing the Plan will be expended this fiscal year. An additional \$92,450 has been budgeted in FY 23/24 for the Sewer System Rate Study and SDC Update, using a combination of Sewer Operating funds and SDCs.

COMMUNITY INVOLVEMENT PROCESS:

The public hearings listed above will provide opportunity for public input. In addition, the Sewer System Rate Study and SDC Update will include a robust public engagement process.

POTENTIAL IMPACTS or BENEFIT TO THE COMMUNITY:

A technically and financially sound plan for providing reliable wastewater treatment, capacity to accommodate future development, and compliance with environmental regulations.

ALTERNATIVES:

The Plan is based on a projected population growth rate that is somewhat aggressive but is consistent with other recently adopted planning documents and with historical growth data. The capital project schedule can be adjusted as appropriate if actual growth rates differ significantly from the projected growth included in the Plan. In addition, some of the recommended hydraulic upgrades might be avoided, depending on the results of more detailed analysis of storage and attenuation in the wastewater collection system, when the next CSMP update is completed.

ATTACHMENTS:

N/A

City of Wilsonville Wastewater Treatment Plant Master Plan

Planning Commission Work Session
October 11, 2023





Introduction

Presenters:

Mike Nacrelli, PE, Senior Civil Engineer

Dave Price, PE, Carollo Engineers



Status Update

- Accommodating Expected Build-Out by 2045
 - Increased industrial discharges to permitted limits
- Capacity Assessment Complete
 - Includes hydraulic modeling of WWTP
- Costs and Schedule for Updated CIP
- Update of Master Plan

Capital Planning and Expected Growth - 2045

- Current Service Area needs
 - 20+ years through 2045
 - Population and associated economic development

Buildout Population Projections (High 2.9%)

2020	2030	2045	2050
25,915	35,163	46,798	50,388

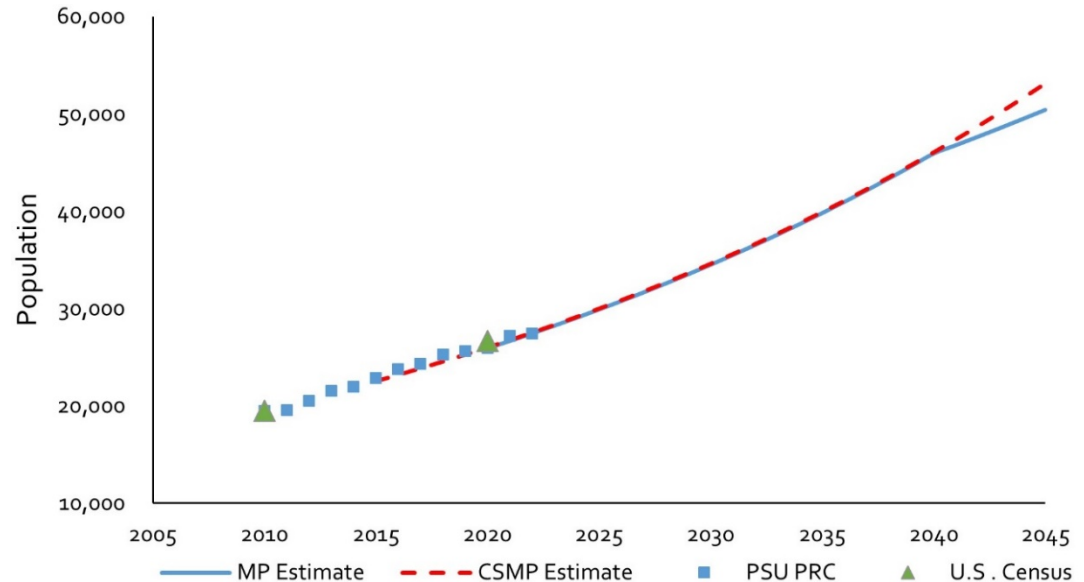

Buildout Service Area - 2045

Land Use	Acreage
Commercial	224
Industrial	2,383.2
Public	482.9
Residential	2,278.3
Town Center	136.1
Village	367.4

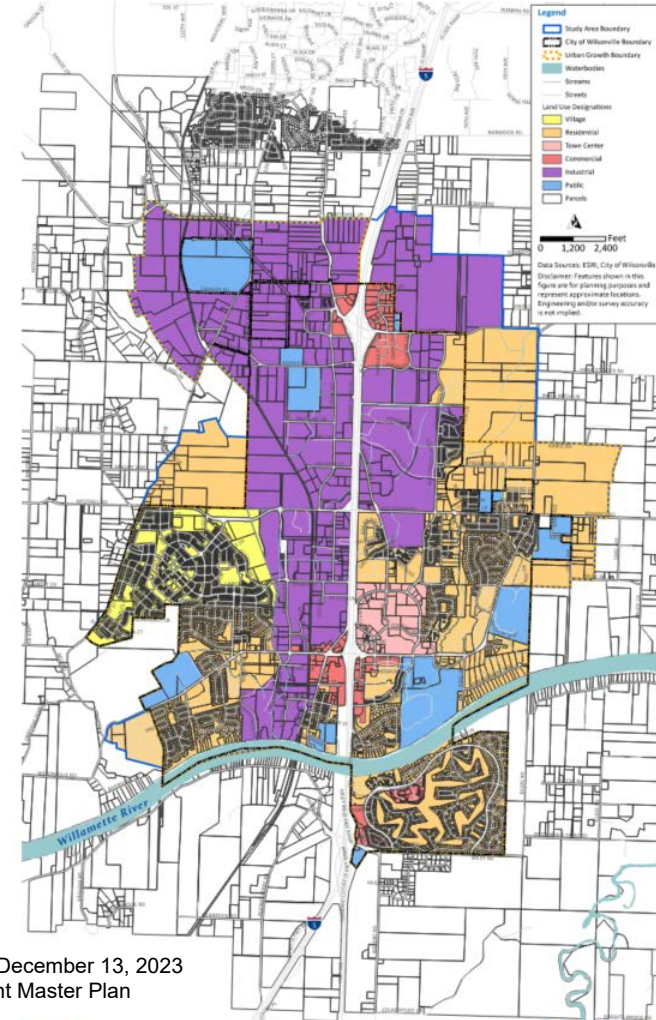

Planning Commission Meeting - December 13, 2023
 Wastewater Treatment Plant Master Plan



Facility Capacity Assessment

- Flows & Loads Updated to reflect Buildout of Service Area
- Projected 2045 flows and loads exceed design criteria (~2X current)

Item	2022	Rated Capacity	Projected 2045
Average Dry Weather Flow, mgd	2.06	4.00	4.17
Average Annual Flow, mgd	2.39	4.48	4.77
Maximum Month Wet Weather Flow, mgd	4.00	6.68	7.76
Max Month BOD ₅ , ppd	11,456	12,900	22,301
Max Month TSS, ppd	9,504	12,500	18,116

Unit Process Capacity Summary

Unit Process	Capacity Limit	Redundancy Criteria	Possible Year of Capacity Exceedance	Identified Alternatives
Secondary Treatment	MW MLSS inventory @ PDF	All units in service	2027	<ul style="list-style-type: none"> New Aeration Basin
Additional Secondary Treatment	MM MLSS inventory @ PDF	One train out of service	2031, 2039, 2044	<ul style="list-style-type: none"> Membrane Bioreactor
Effluent Cooling Towers	6 MGD (May 1 – October 31)	All units in service	2039	<ul style="list-style-type: none"> Additional Cooling Tower
UV Effluent/Outfall	16 MGD	All units in service	2041	<ul style="list-style-type: none"> Upsizing outfall piping of MH-B to future MH-E



Alternatives Evaluation

- Consider alternatives for process units identified as capacity deficient
- Secondary Process
 - Add new Aeration Basin & additional blower
 - Phase MBR technology (includes hydraulic upgrades)
- Solids Thickening and Dewatering
 - Replace GBTs and Centrifuge units during the planning period – expected useful life
- UV System and Outfall Piping
 - Replace aging equipment and upgrade hydraulic capacity
- Prior conclusions – plan to replace based on condition/age during planning period:
 - Backup UV system
 - Solids dryer
 - Dewatering Centrifuges
 - Thickening GBTs

Recommended Plan

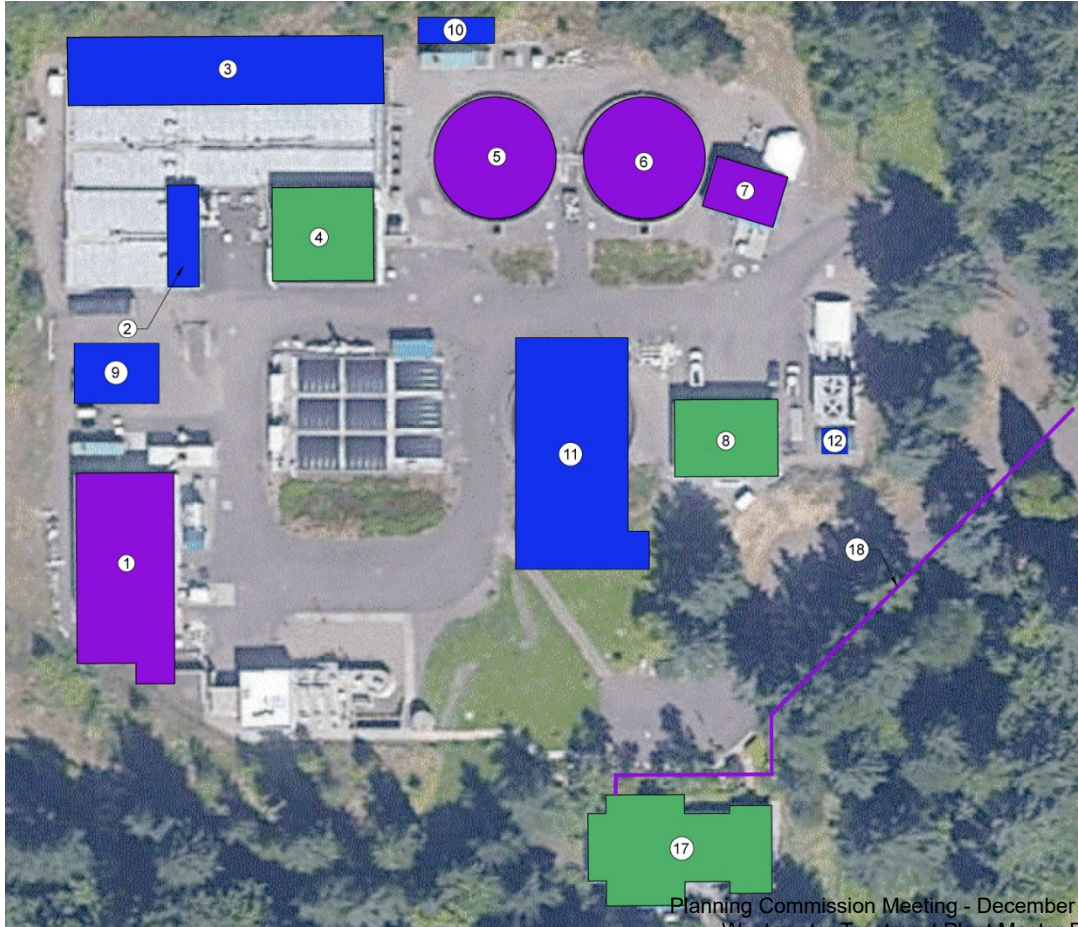

- ③ New Aeration Basin
- ② Additional Aeration Blowers
- ⑨ New Fine Screens
- ⑩ New Emergency Generator
- ⑪ New MBR Facility
- ⑫ New Cooling Tower
- ⑦ Replace backup UV system
- ① Plan to replace Solids Dryer & Centrifuges
- ⑤ ⑥ Replace Clarifier 1 & 2 mechanisms
- ④ ⑧ ⑰ Seismic retrofits of buildings
- ⑱ New fiber optic connection

Solids process study

Proposed Project Phasing Schedule

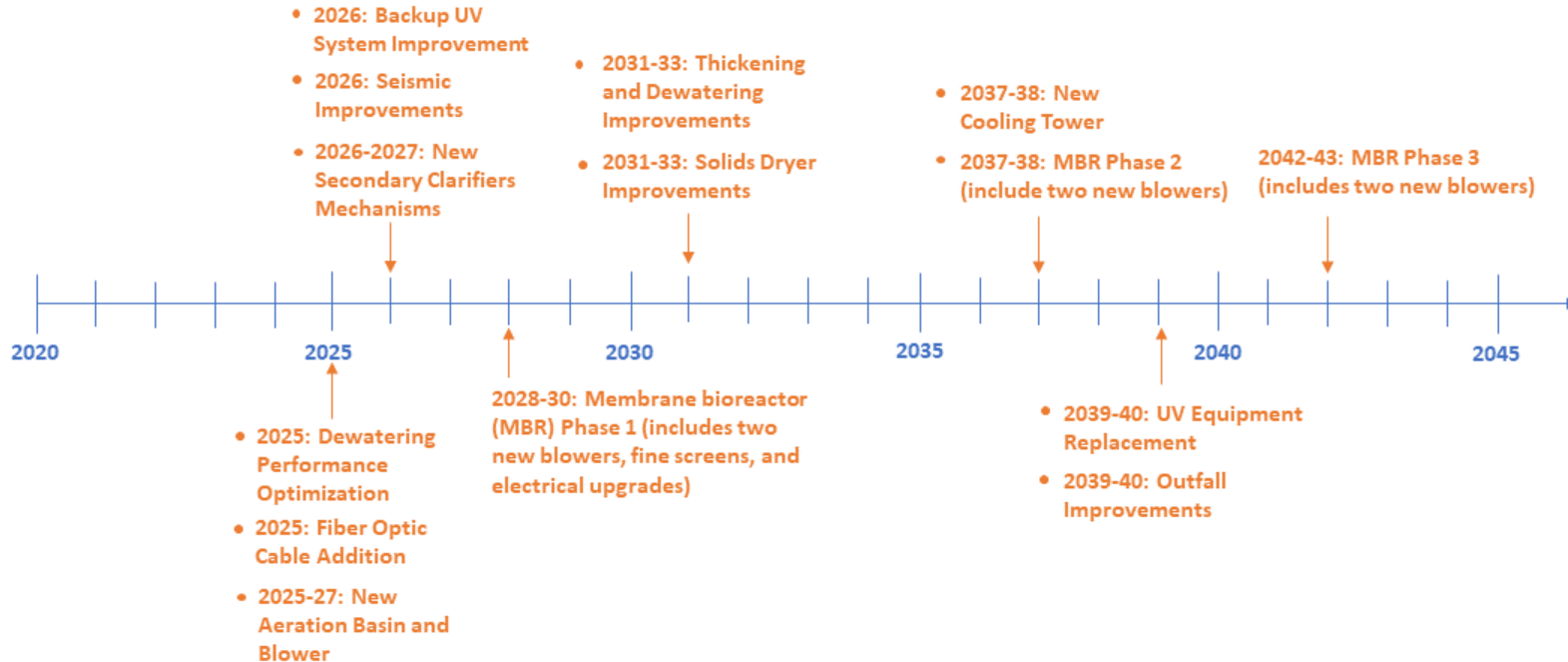

Project Cost

DESCRIPTION	ESTIMATED TIMEFRAME	AUGUST 2023 PROJECT COST
Dewatering Performance Optimization	2025	\$150,000
Fiber Optic Cable Addition	2025	\$60,000
Backup UV System Improvement	2026	\$1,705,000
Seismic Improvements	2026	\$1,082,000
New Aeration Basin + Blower + Retaining Wall	2025 – 2027	\$10,179,000
New Secondary Clarifier Mechanisms	2026 – 2027	\$1,775,000
MBR Phase 1 + 2 Blowers + Fine Screens + Electrical Upgrades	2028 – 2030	\$69,637,000
Solids Dryer Improvement	2031 – 2033	\$17,130,000
Thickening + Dewatering	2031 – 2033	\$3,701,000
Cooling Tower	2037 – 2038	\$642,000
MBR Phase 2 + 2 Blower	2037 – 2038	\$2,242,000
UV Equipment Replacement	2039 – 2040	\$2,571,000
Outfall Improvements	2039 – 2040	\$1,244,000
MBR Phase 3 + 2 Blower	2042 – 2043	\$8,030,000
TOTAL	Planning Commission Meeting - December 13, 2023 Wastewater Treatment Plant Master Plan	\$120,148,000



Estimated Cash Flow

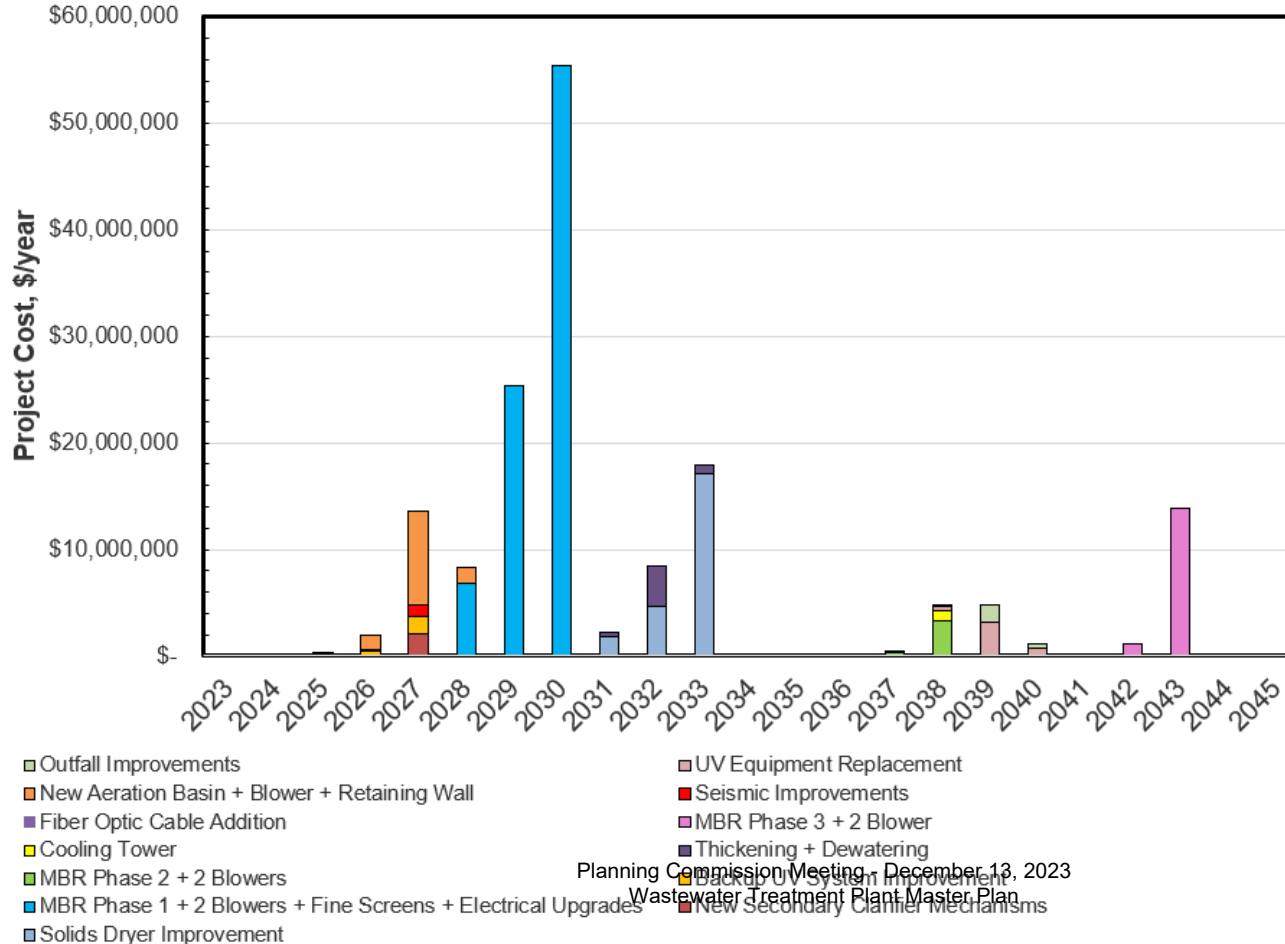

Planning Commission Meeting - December 13, 2023
 Wastewater Treatment Plant Master Plan



Next Steps

- City Council Work Session 11/6/23
- Planning Commission Public Hearing 12/13/23
- City Council Public Hearing 1st Reading 1/4/24
- City Council 2nd Reading 1/18/24
- Sewer System Rate Study and SDC Update 2024

Questions?

- Ms. Weiland added that LID and vegetated stormwater facilities provided truly good pollutant removal in accordance with effectiveness information that was well documented. Different processes were used, and vegetation enhances uptake. Through these facilities, retention and infiltration of stormwater was encouraged, which was another means to remove pollutants before they discharged via overland flow or pipe flow into receiving water, so the types of facilities proposed were intentionally in alignment with the City's design standards and MS4 permit requirements.

4. Wastewater Treatment Plant Master Plan (Nacrelli)

Mike Nacrelli, Senior Civil Engineer, and Dave Price, Senior Civil Engineer, Carollo Engineers, presented on the update Wastewater Treatment Plant Master Plan via PowerPoint, reviewing key components of the Master Plan which would accommodate expected demand for build out by 2045. Highlights included details regarding the completed facility capacity assessment, costs and a schedule for the updated Capital Improvements Program (CIP), an alternatives evaluation and a breakdown of costs by project, estimated cash flow, and the next steps for advancing the Master Plan for adoption.

and the additional changes since the last work session with the Commission.

Discussion and feedback from the Planning Commission was as follows with responses by Staff to Commissioner questions as noted:

- In September 2022, the estimate was \$75 million which moved to \$120 million in the span of a year with the increased industrial discharges.
 - Mr. Nacrelli noted an oversight in the presentation, stating the \$75 million had not included the engineering portion, it was only construction. The actual cost should have been in the \$90,000s.
- If the project were not space constrained, what would the project cost and overall plan look like? Would clarifiers be added instead of adding a membrane bioreactor (MBR)? Considering the huge sum of money involved, maybe it would be cheaper overall to acquire some additional land south of the existing facility to add more equipment, rather than this huge increase for the MBR. The river was south of the facility, but there were a lot of trees that could be cut down.
 - Mr. Nacrelli responded Staff could cost out what a conventional expansion would take and how much land would be required; however, the direction provided was that there was no room to grow.
 - Ms. Guile-Hinman understand the facility was all surrounded by Boones Ferry Park, and there were deed restrictions that did not allow the City to use it for anything other than a recreational use.
 - Mr. Nacrelli clarified the land on the east side had a large grade adjacent to where the new aeration basin would go in the northeast corner.
 - Mr. Price added a significant retaining wall would have to be built there in order to put in the additional aeration basin, so the area was already tight due to the slopes.
- At a high level, it would be good to double check that there is no physical space to put in a conventional facility, because this was a huge sum of money, especially with the \$60 million outlay in 2030. It would be good to make sure the City was looking at all the options out there.

- Mr. Nacrelli stated they could run the numbers and understand how much space would be needed, but he was pretty satisfied with the property footprint; perhaps he could come up with a map that extended beyond the area.
- If deed restrictions prevented the City for adding land, no additional analysis was needed, but if there was space or an opportunity to be creative, then be creative about a more conventional plant. If not, then just let the Commission know.
 - Mr. Price added access was also required on the site for trucks with trailers, so there was limitations with travel ways and the plan did not show the slopes on three sides of the site. Based on the team's analysis, there were not too many square feet on the site that were not already being used. When the facility was upgraded in 2011/2012, one notion was that beyond the three existing aeration basins and clarifiers that the next step was to put some [inaudible] but he believed that project predated the collection system at the time, so it did not evaluate the full indications of what that might be. He wanted to make sure the Commission considered the conventional options as well as the expectations coming out of the Master Plan update and whether things could be [inaudible] or reduced. A scenario that would reduce the cost of Phase 1, but would be at least \$10 million to eliminate the need for some of those future projects, which would be something to think about, because in that scenario the City would be running kind of a combined conventional/membrane plant. The two distinct clarifiers would not go away until Phase 3. The project team was trying to preserve the City's conventional facility for as long as possible, but it would cost to maintain the existing facilities and give you less energy for chemicals to operate that facility than a more complicated, high intensity system line an MBR.
 - Mr. Nacrelli suggested they could add property lines and contours to the site plan. (Slide 9)
- Regarding an increase in industrial discharge, what was the current industrial discharge versus what was in the plan versus what is the maximum? And where was the City in that window, right at the maximum of what was theoretically possible from the permits in this plan, or some amount lower than that? That information would be helpful to have for the next go around.
 - Mr. Nacrelli believed they could provide those numbers, which would be in the Master Plan attached to the Staff report. He confirmed the assumption was that all the City's permanent industries would be discharging the maximum amount, which they were not currently doing, so that was a pretty significant impact, especially since they were higher dischargers. The lows were just as important to evaluate capacity. Those numbers would be incorporated into the slides.
- Incorporating the risks of not implementing the recommended plan in the master plan was suggested. Communities along the Willamette were having wastewater failures and having boil orders for water. Articulate the consequences of not doing this to our river environment would be great.
 - Mr. Nacrelli responded a chapter in the regulatory constraints essentially stated that once you start exceeding your limits, you get financial [inaudible], and the City could get to a point where a moratorium would have to be issued until the issues were fixed.
 - Mr. Price added that typically with improvement at this scale, community outreach would be incorporated into the more detailed planning and design steps to help educate people about rates and charges and to make sure the message got out there about why these improvements were needed.

- With only two funding sources noted, rates and SDCs, at the current rates and expected SDCs, what was the City's shortfall and how would that shortfall be made up?
 - Mr. Nacrelli responded [inaudible] not part of the Master Plan's scope, noting the rate study would delve into those details.
 - Mr. Price added also need to consider the condition-related verses capacity-related improvements.
- Mr. Nacrelli confirmed the rate study would be completed after City Council adopted the Master Plan.
 - A comment was made that the City was creating the Master Plan without knowing how to pay for it, which was not how budgeting worked in real life.
- Zach Weigel, City Engineer, added further context on how the master planning worked. The City was going to grow to a certain population, and these projects were needed for the treatment plant to meet the population demand. When master planning, the needs were identified, then a rate study determined the impact on fees and development costs.
- Mr. Weigel confirmed a certain portion of development fees went toward wastewater, and each CIP project would be split on base with a portion that serves new development and serves existing customers, and that portion of new growth gets figured into the SDC cost.
- SDCs affect affordability.
- The Commission discussed growth rates when the housing report came out, and the City's actual growth numbers were outpacing Metro's projections. Which numbers were used in the Master Plan engineering?
 - Mr. Weigel stated the project team used the same numbers from the collection system master plan, which was an aggressive growth rate that was trending with what the City has been seeing over the last 10 years on average. It was hard to know what was going to happen. Was it going to slow down? Was Metro going to put limits on the City to meet certain housing projections? Staff believed the aggressive growth rate was the right measure to use for this Master Plan.
 - Mr. Nacrelli noted the Master Plan numbers were compared with Metro's Transportation Analysis projections, and they were very close.
 - Mr. Weigel confirmed there was really no way to avoid MBR. There were ways to avoid additional chambers of MBR that Staff would be tracking over time, but that was typical with a master plan; the needs were identified, population growth, flow, and needs were tracked over time, and the projects were implemented when they were needed. And then, every 10 years or so, the Master Plan is updated when a deeper dive is taken into the data to make sure the City was following those projections and then updating the Master Plan as needed.

Chair Heberlein called for a brief recess and reconvened the meeting at 8:45 pm.

INFORMATIONAL

5. 2023 Transportation Performance Monitoring Report (Pepper)

Amy Pepper, Development Engineering Manager, presented a report card on the City's performance of the City's Transportation System Plan (TSP), its policies, programs, and projects, and how the City's projects had measured up to Goals 1 through 7 of the TSP, along with recommended actions to lead to desired outcomes. A full update of the report was included in the packet.



PLANNING COMMISSION

WEDNESDAY, OCTOBER 12, 2022

PUBLIC HEARING

2. Wastewater Treatment Plant Master Plan (Nacrelli) *(No staff presentation)* - CANCELLED



MEMO
Engineering Division

DATE: October 5, 2022

TO: Planning Commission

FROM: Mike Nacrelli, PE
Senior Civil Engineer

RE: *Cancellation of October 12, 2022 Public Hearing for the Wastewater Treatment Plant Master Plan*

The Wastewater Treatment Plant (WWTP) Master Plan has used a study area boundary consistent with recently completed master planning documents, including the 2012 Water System Master Plan, the 2014 Wastewater Collection System Master Plan, and the 2017 Water Treatment Plant Master Plan. However, the 2018 Basalt Creek Concept Plan has altered the future service area that will send flows to the WWTP, requiring further analysis of the projected wastewater flows and loads and the planned capital improvements to provide the needed treatment capacity. In order to allow adequate time to complete this additional analysis, I request that the public hearing for the WWTP Master Plan currently scheduled with the Planning Commission for October 12, 2022 be cancelled and rescheduled for February 8, 2023.

Respectfully,

Michael Nacrelli

Project Manager

Commissioner Mesbah asked if **Mr. Nacrelli** meant a certain quality of effluent since anything produces effluent; perhaps, “high quality effluent” should be used.

Mr. Nacrelli agreed something might be missing there, but without hearing the recording, the quality of effluent was the only thing that made sense.

Amanda Guile-Hinman, City Attorney, advised postponing the consideration of the minutes to allow time to check the audio recording.

Chair Heberlein stated consideration of the September 14, 2022 Planning Commission Minutes would be delayed to the next Planning Commission meeting to clarify the language on Page 9.

LEGISLATIVE HEARING

2. Wastewater Treatment Plant Master Plan (Nacrelli) (No staff presentation) - CANCELLED

Chair Heberlein noted tonight’s public hearing had been cancelled and would be rescheduled to a later date.

Miranda Bateschell, Planning Director, asked that anyone present for the hearing add their contact information to the sign in sheet to receive notification about the new public hearing date. She also offered to provide the project manager’s business card.

WORK SESSION

3. Transit Master Plan (Lewis)

Kelsey Lewis, SMART Grants and Programs Manager, introduced the City consultant who would present information about the public engagement conducted on the Master Plan over the summer.

Brenda Martin, Consultant, EnviroIssues, presented via PowerPoint a summary of the engagement conducted as part of the SMART Transit Master Plan Update. She highlighted the purpose of the Master Plan Update and described the outreach methods used to gather public input from various stakeholders and diverse groups of citizens, including underrepresented communities. She also reviewed the key findings from the data collected from surveys and the stakeholder’s workshop which identified ridership patterns and included requests for transit time and frequency changes, as well as additions to SMART’s service routes, which included connections to other destinations in the region.

Questions from the Commission were as follows with responses as noted:

- Why was there such a low turnout for the in-person stakeholder workshop where only 18 people attended after more than 100 invites were sent out?
 - **Ms. Martin** noted the project team made about 150 calls and sent emails, but she believed that ultimately, it was just the day and time, coupled with not being able to invite the right people to come from certain organizations due to changes in employment. The team did share the survey with most of those invitees, so the team did collect some feedback from those organizations. She believed having one time and place for attendance was difficult for some people.



PLANNING COMMISSION

WEDNESDAY, SEPTEMBER 14, 2022

WORK SESSION

3. Wastewater Treatment Plant Master Plan (Nacrelli) (30 minutes)



PLANNING COMMISSION WORK SESSION STAFF REPORT

Meeting Date: September 14, 2022		Subject: Wastewater Treatment Plant Master Plan	
		Staff Member: Mike Nacrelli, Senior Civil Engineer	
		Department: Community Development	
Action Required		Advisory Board/Commission Recommendation	
<input type="checkbox"/> Motion <input type="checkbox"/> Public Hearing Date: <input type="checkbox"/> Ordinance 1 st Reading Date: <input type="checkbox"/> Ordinance 2 nd Reading Date: <input type="checkbox"/> Resolution <input checked="" type="checkbox"/> Information or Direction <input type="checkbox"/> Information Only <input type="checkbox"/> Council Direction <input type="checkbox"/> Consent Agenda		<input type="checkbox"/> Approval <input type="checkbox"/> Denial <input type="checkbox"/> None Forwarded <input checked="" type="checkbox"/> Not Applicable Comments: N/A	
Staff Recommendation: Provide requested input regarding recommended capital improvement plan.			
Recommended Language for Motion: N/A			
Project / Issue Relates To:			
<input checked="" type="checkbox"/> Council Goals/Priorities: Align infrastructure plans with sustainable financing resources.	<input type="checkbox"/> Adopted Master Plan(s):	<input type="checkbox"/> Not Applicable	

ISSUE BEFORE PLANNING COMMISSION:

Provide feedback and input on components of the Wastewater Treatment Plant (WWTP) Master Plan.

EXECUTIVE SUMMARY:

This new City of Wilsonville (City) Wastewater Treatment Plant (WWTP) Master Plan (the Plan) has been developed to satisfy requirements associated with the State of Oregon Department of Environmental Quality (DEQ) guidance document entitled “Preparing Wastewater Planning Documents and Environmental Reports for Public Utilities.” To accommodate future flows and loads, projections were developed based on population projections and referencing WWTP historical data and DEQ wet weather project methodologies. Similarly, to accommodate future water quality regulations, the Plan is adaptive and considers potential future regulatory changes.

The City prepared the Plan with the goal of developing a capital plan that identifies improvements required through the planning period (today through 2045) to comply with requirements of the WWTP National Pollutant Discharge Elimination System (NPDES) permit and potential future regulatory requirements, while accommodating growth identified in the City of Wilsonville Comprehensive Plan (October 2018, updated June 2020 - the 2018 Comprehensive Plan). These improvements are designed to provide the best value to the City’s ratepayers by maximizing the use of existing infrastructure and improving system operation while continuing to protect water quality and human health and supporting economic development, consistent with goals and policies contained in the 2018 Comprehensive Plan and 2021-2023 City Council Goals.

The City’s WWTP was originally built in 1971 and discharges treated effluent to the Willamette River. The WWTP underwent major upgrades in 2014 to expand the average dry weather capacity to four million gallons per day (mgd) to accommodate the City’s continued growth. The WWTP processes include headworks screening and grit removal facilities, aeration basins, stabilization basins, secondary clarifiers, biosolids processing, cloth filtration, and disinfection processes. Additionally, the City contracts with Jacobs for operation of the wastewater treatment plant, located at 9275 Southwest Tauchman Road.

This Plan identifies improvements taking into consideration:

- The age and condition of existing process equipment and structures,
- Growth in demand for sewer service due to increased population and economic development over the planning period,
- Potential changes to water quality regulations impacting process needs in order to meet effluent limitations and discharge prohibitions imposed by the Oregon Department of Environmental Quality (DEQ), and
- Consistency with the 2018 Comprehensive Plan and City Council 2021-2023 Goals 5, 6 and 7.

Updated Growth Projection and Capital Improvement Plan

The previous (7/13/2022) work session included a capital improvement plan based on population growth projections over the planning period obtained from Metro. The growth projections have since been updated to an assumed 2.9% annual population increase, consistent with recent planning documents adopted by the City, including the Wastewater Collection System Master Plan (November 2014) and the Willamette River Water Treatment Plan Master Plan Update (March 2018). This change results in a considerably higher level of capital investment over the planning period, as reflected in the table below.

Project Description	Timeframe	Cost*
Dewatering Performance Optimization	2023	\$155,724
UV System Improvement	2023	\$1,370,369
Fiber Optic Conduit Addition	2023	\$45,679
Seismic Improvements	2024	\$841,323
New Aeration Basin and Blower	2025	\$6,928,208
Replace Secondary Clarifier Mechanisms	2026	\$1,382,827
Membrane Bioreactor (MBR) Phase 1 (includes new blower, fine screens, and electrical upgrades)	2028 – 2029	\$31,811,200
New Solids Dryer	2031 – 2032	\$13,371,479
MBR Phase 2 (includes new blower)	2033 – 2034	\$6,211,200
Thickening and Dewatering Improvements	2035	\$2,854,359
New Cooling Tower	2036 – 2037	\$452,138
MRB Phase 3 (includes 2 new blowers)	2038	\$4,742,400
MBR Phase 4 (includes 2 new blowers)	2040 – 2041	\$5,142,400
Total		\$75,309,306
*Costs are shown in 2022 dollars and include 25% for engineering, legal, and administration.		

As shown in the table above, the most significant impact to the required level of capital investment is the need for membrane bioreactor (MBR) facilities. These are state-of-the-art, compact facilities that provide a high level of treatment. The adjusted growth projection results in an approximate doubling of the City population over the planning period. Due to the limited amount of space available at the existing WWTP site, MBR facilities are the only feasible means of providing the necessary treatment to accommodate such a substantial rate of growth.

EXPECTED RESULTS:

The Plan includes a list of recommended capital improvements, along with an anticipated schedule for completion and preliminary cost estimates. These improvements will provide the basis for an analysis of sewer rates and system development charges (SDCs) that will be necessary to provide adequate funding to implement to required upgrades.

TIMELINE:

This is the third in a series of presentations to the Planning Commission and City Council. Completed and planned meetings are as follows:

- Planning Commission Work Session 7/13 (completed)
- City Council Work Session 8/1 (completed)
- Planning Commission Work Session 9/14
- Planning Commission Public Hearing 10/12
- City Council Work Session 11/7
- City Council Public Hearing 1st Reading 11/21
- City Council 2nd Reading 12/5

CURRENT YEAR BUDGET IMPACTS:

The remaining contract balance for finalizing the Plan will carry over into FY 22/23. An additional \$92,450 has been budgeted in FY 22/23 for the Sewer System Rate Study and SDC Update, using a combination of Sewer Operating funds and SDCs.

COMMUNITY INVOLVEMENT PROCESS:

The public hearings listed above will provide opportunity for public input. In addition, the Sewer System Rate Study and SDC Update will include a robust public engagement process.

POTENTIAL IMPACTS or BENEFIT TO THE COMMUNITY:

A technically and financially sound plan for providing reliable wastewater treatment, capacity to accommodate future development, and compliance with environmental regulations.

ALTERNATIVES:

The Plan is based on a projected population growth rate that is somewhat aggressive but is consistent with other recently adopted planning documents and with historical growth data. The capital project schedule can be adjusted as appropriate if actual growth rates differ significantly from the projected growth included in the Plan.

ATTACHMENTS:

N/A

City of Wilsonville Wastewater Treatment Plant Master Plan

Planning Commission Work
Session

September 14, 2022





Introduction

Presenters:

Mike Nacrelli, PE, Senior Civil Engineer

Dave Price, PE, Carollo Engineers



Status Update

- July 13 Work Session Comments
- Accommodating Expected Build-out UGB Growth
- Capacity Assessment Complete
- Costs and Schedule for Updated CIP Drafted
- Update of Master Plan Chapters in Progress
- September 28 Open House



Facility Capacity Assessment

- Flows & Loads - Updated to reflect Build-out of USB
- Existing WWTP design (2014 expansion) – ADWF – 4 mgd
- Projected 2045 flows and loads exceed design criteria (~2X current)

Item	Existing	Projected 2045
Average Dry Weather Flow, mgd	1.93	4.16
Average Annual Flow, mgd	2.23	4.77
Maximum Month Wet Weather Flow, mgd	3.78	7.92
Average Annual BOD ⁵ , ppd	7,534	16,333
Average Annual TSS, ppd	6,484	13,789

Planning Commission Meeting, December 13, 2023
Wastewater Treatment Plant Master Plan

Unit Process Capacity Summary

Unit Process	Design Parameter	Redundancy Criteria	Possible Year of Capacity Exceedance	Identified Alternatives
Secondary Treatment	MM MLSS inventory @ PDF	All units in service	2026	<ul style="list-style-type: none"> • New Aeration Basin • New Secondary Clarifier
Aeration Blowers	Peak BOD Load	Largest unit out of service	2026	<ul style="list-style-type: none"> • Additional Blower
Additional Secondary Treatment	MM MLSS inventory @ PDF	One train out of service	2031, 2034, 2038, 2042	<ul style="list-style-type: none"> • Membrane Bioreactor
Effluent Cooling Towers	6 MGD (May 1 – October 31)	All units in service	2037	<ul style="list-style-type: none"> • Additional Cooling Tower



Alternatives Evaluation

- Consider alternatives for process units identified as capacity deficient
- Secondary Process
 - Add new Aeration Basin & additional blower 2026
 - Phase MBR technology starting later
- Solids Thickening and Dewatering
 - Replace GBTs and Centrifuge units during the planning period
 - expected useful life
- Prior conclusions – plan to replace based on condition/age during planning period:
 - Backup UV system
 - Solids dryer
 - Dewatering Centrifuges
 - Thickening GBTs

Recommended Plan

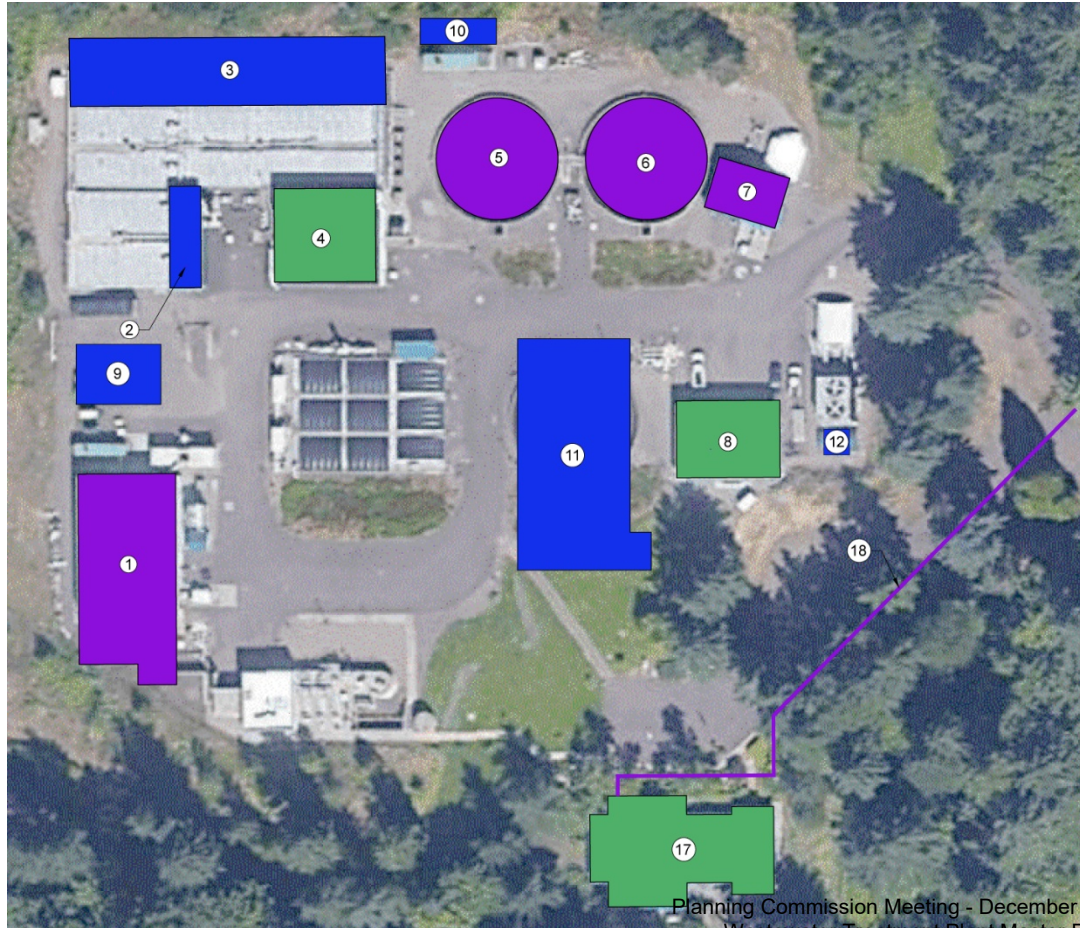

- ③ New Aeration Basin
- ② Additional Aeration Blowers
- ⑨ New Fine Screens
- ⑩ New Emergency Generator
- ⑪ New MBR Facility
- ⑫ New Cooling Tower
- ⑦ Replace backup UV system
- ① Plan to replace Solids Dryer & Centrifuges
- ⑤ ⑥ Replace Clarifier 1 & 2 mechanisms
- ④ ⑧ ⑰ Seismic retrofits of buildings
- ⑱ New fiber optic connection

Solids process study

Proposed Project Phasing Schedule

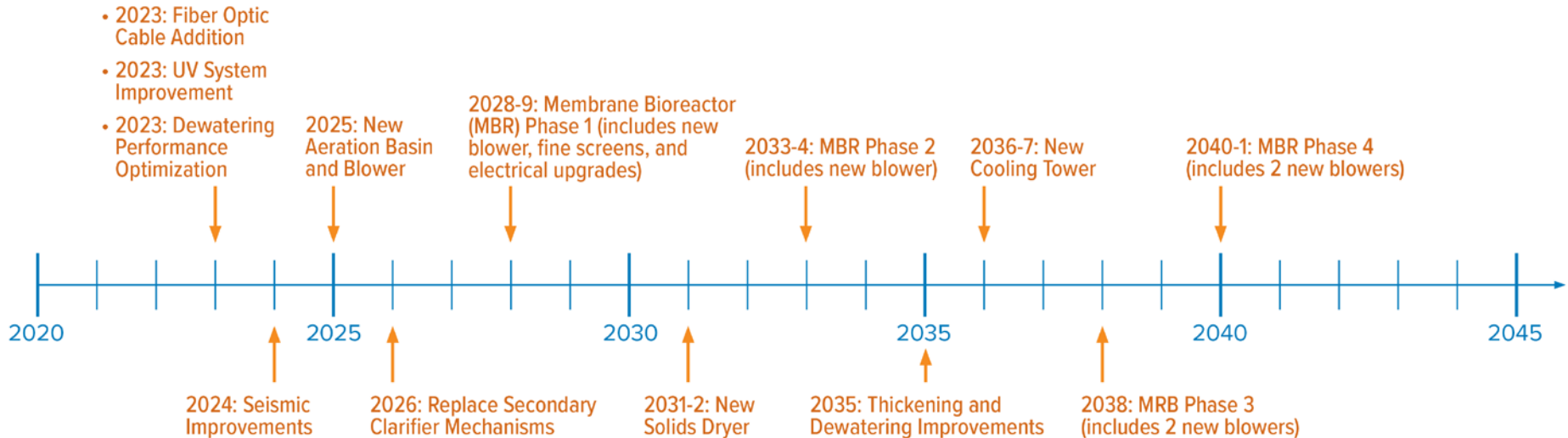

Project Costs (2022 Dollars)

DESCRIPTION	TIMEFRAME	ESTIMATED COST	TOTAL WITH 25% E, L, & A
Dewatering Performance Optimization	2023	\$ 155,724	\$ 155,724
Trojan 4000 UV System Improvement	2023	\$ 1,370,369	\$ 1,712,961
Fiber Optic Conduit Addition	2023	\$ 45,679	\$ 57,099
Seismic Improvements	2024	\$ 841,323	\$ 1,051,654
New Aeration Basin + Blower + Retaining Wall	2025	\$ 6,928,208	\$ 8,660,260
Replace Secondary Clarifier Mechanisms	2025 – 2026	\$ 1,382,827	\$ 1,728,534
MBR Phase 1 + 1 Blower + Fine Screens + Electrical Upgrades	2028 – 2030	\$ 31,811,200	\$ 39,764,000
New Solids Dryer	2031 – 2033	\$ 13,371,479	\$ 16,714,349
MBR Phase 2 + 1 Blower	2033 – 2034	\$ 6,211,200	\$ 7,764,000
Thickening + Dewatering	2035	\$ 2,854,359	\$ 3,567,948
New Cooling Tower	2037	\$ 452,138	\$ 565,173
MBR Phase 3 + 2 Blowers	2037 – 2038	\$ 4,742,400	\$ 5,928,000
MBR Phase 4 + 2 Blowers	2040 – 2041	\$ 5,142,400	\$ 6,428,000
TOTAL		\$ 75,309,306	\$ 94,097,702



Draft Cash Flow

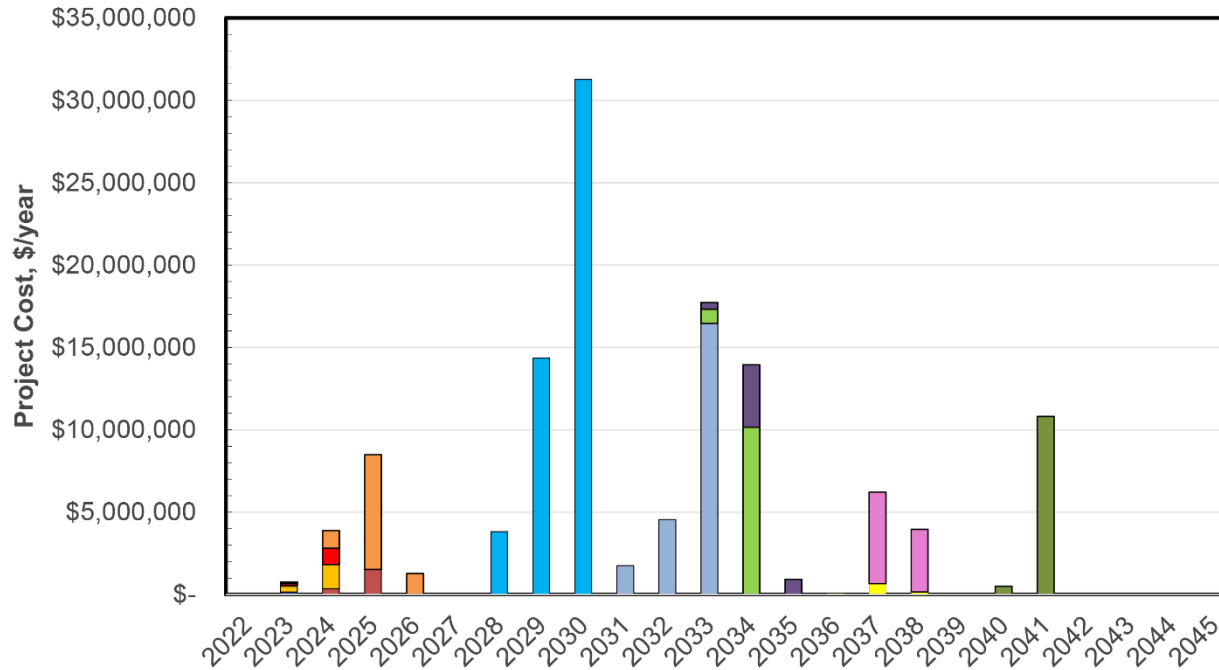

- Dewatering Performance Optimization
- New Secondary Clarifier Mechanisms
- Trojan 4000 UV System Improvement
- Thickening + Dewatering
- MBR Phase 3 + 2 Blower
- Seismic Improvements
- MBR Phase 4 + 2 Blower
- Solids Dryer Improvement
- MBR Phase 1 + 1 Blowers + Fine Screens + Electrical Upgrades
- MBR Phase 2 + 1 Blowers
- Cooling Tower
- Fiber Optic Cable Addition
- New Aeration Basin Blower + Retaining Wall

Planning Commission Meeting - December 13, 2023
 Wastewater Treatment Plant Master Plan



Next Steps

- Virtual Public Open House (9/28)
- Planning Commission Public Hearing 10/12
- DEQ review and approval of Plan
- City Council Work Session 11/7
- City Council Public Hearing 1st Reading 11/21
- City Council 2nd Reading 12/5
- Sewer System Rate Study and SDC Update FY23

Questions?

Reference Slides

Capital Planning and Expected Growth - 2045

- Current Service Area needs
 - 20+ years through 2045
 - Population and associated economic development

2015	2020	2030	2045
22,870	25,915	29,756	30,566

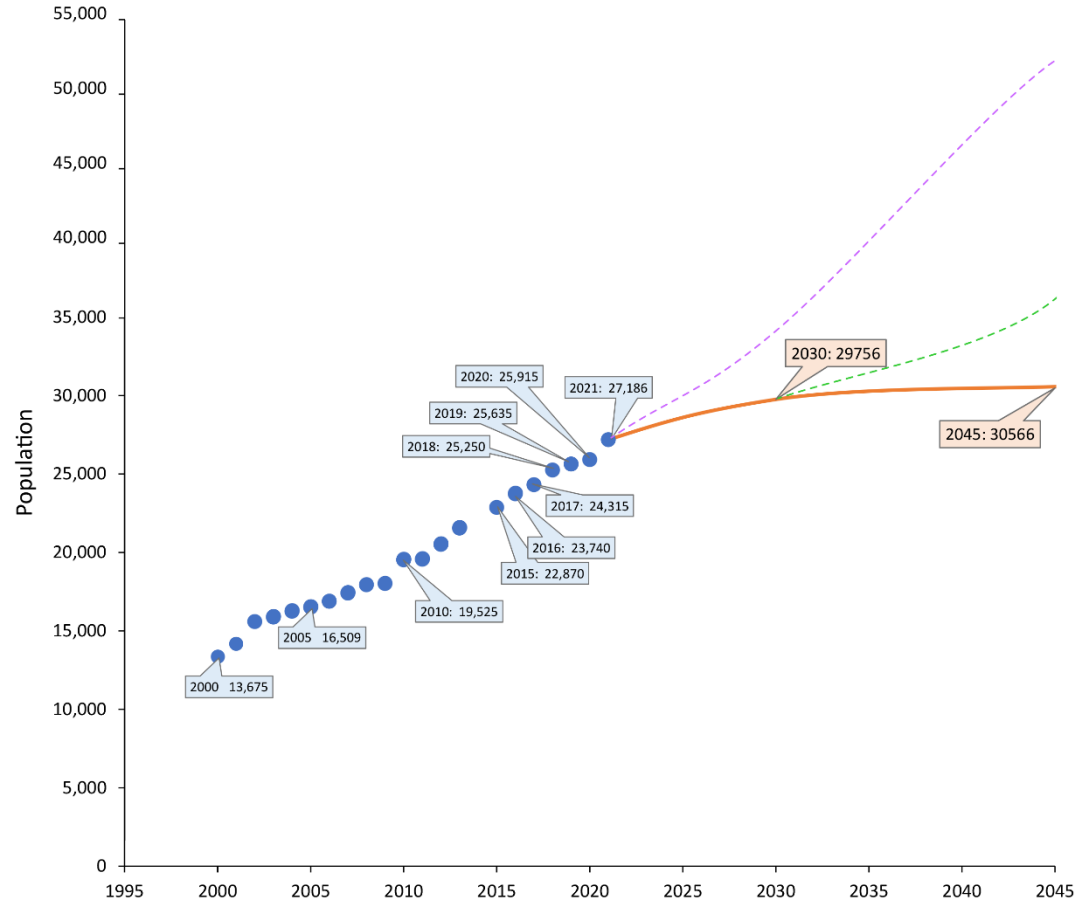

Planning Commission Meeting - December 13, 2023
 Wastewater Treatment Plant Master Plan



Condition Assessment

- Prioritize 2019 findings of consultant assessments
 - Secondary clarifiers
 - UV system
- Geotechnical and seismic evaluations
 - Older buildings found to present moderate risk
 - Identified mitigations to address seismic concerns
 - Operations Building
 - Process Gallery
 - Workshop

Alternatives Evaluation

- Solids Dryer – driven by performance, not capacity
 - Further study, placeholder to expand dewatering and drying building, add new paddle dryer, refurbish existing dryer (backup)
 - Largest potential investment in Master Plan

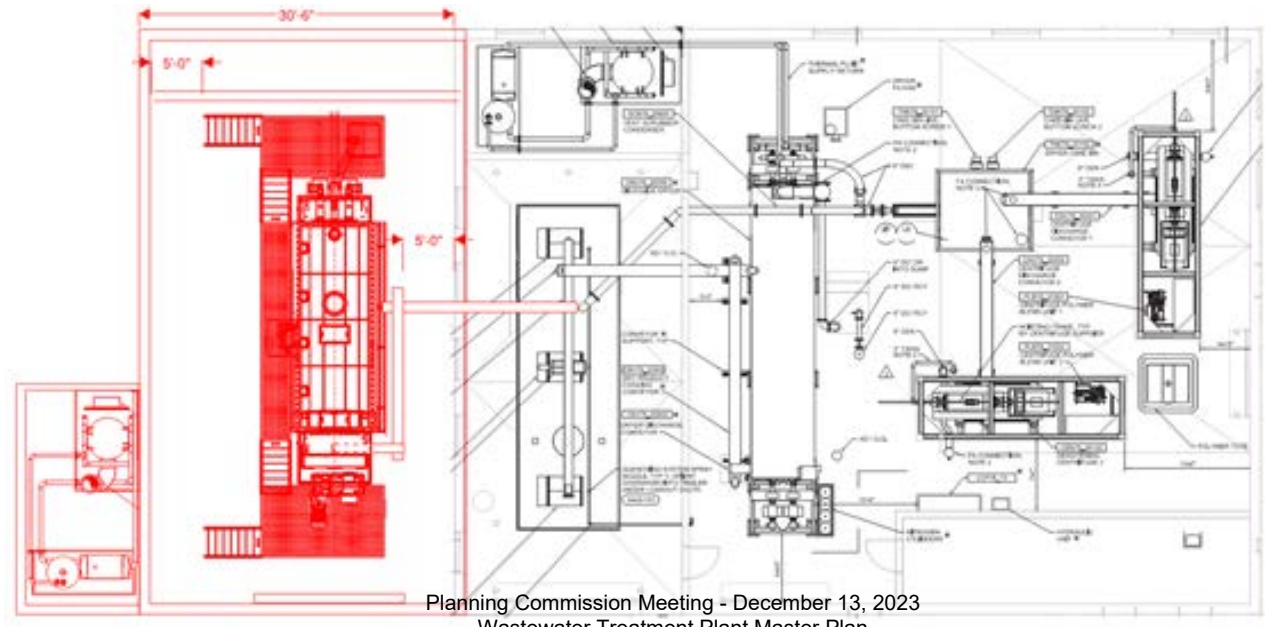

Planning Commission Meeting - December 13, 2023
Wastewater Treatment Plant Master Plan



Asset Condition Assessment

- Process Condition/Age Drivers
 - 2014 project facilities and equipment in service > 30 years by 2045
 - Solids facilities –
 - Performance issues
 - Solids Dryer fire (2019), component failures (2021), uneven performance
 - Solids Dewatering Centrifuges uneven performance (2020/21)
 - Secondary clarifiers – Pre-date 2014 upgrades, near term mechanism replacements, clarifiers no. 1 and 2
 - UV Disinfection – backup unit pre-dates 2014 upgrades, near term replacement



Potential Regulatory Drivers

- DEQ - Total Maximum Daily Load (TMDL)
Lower Willamette River
- Dissolved oxygen & nutrients
 - Nutrients can contribute to low oxygen conditions
 - Anticipate and accommodate future phosphorous, possibly nitrogen limits
- Pay attention to Willamette River
temperature concerns

- **Mr. Green** replied some probability or possibility of growth happening was anticipated if there was an expansion of the airport area, resulting in the development area potentially expanding outward as well.
 - He clarified these were not necessarily trying to anticipate specific events happening that would lead to development in those areas. It was saying development in the area around the airport, such as an industrial development located one parcel away from the through the fence, might occur due to its proximity to the airport.

Ms. Bateschell clarified the project team had a work session with the City Council on Monday to review the draft policies and get Council's input. The collective input received would refine what came before the Commission in November.

3. Wastewater Treatment Plant Master Plan (Nacrelli)

Mike Nacrelli, Senior Civil Engineer updated on the progress of the Wastewater Treatment Master Plan (WWTP) process via PowerPoint noting the growth projections presented to the Commission in July were based on lower growth projections from Metro. Following discussions with the Planning Commission and internal with management, the project team [we] went back and looked at the higher growth curve, which was just under 3 percent annually, and reran the numbers for the modeling of the flows and loads at the plant, as well as the impact on plant capacity and the capital investment required to handle that level of growth, which resulted in substantial changes. (Slide 3) An updated project phasing schedule and cost estimates were created for the projects and all the other portions of the Master Plan document impacted by these changes were being updated as well. An online public open house would begin September 28th for any members of the general public who wanted to provide input.

Dave Price, Carollo Engineers, continued the PowerPoint presentation on the WWTP Master Plan process, reviewing the updates made to the Facility Capacity Assessment and Unit Process Capacity Summary, given the higher growth projections from Metro; the Alternatives Evaluation and Recommended Plan for the required improvement projects, including new capacity upgrades, as well as the now more accelerated Project Phasing Schedule. With the higher growth scenario, the Project Costs had increased to more than three times the approximately \$31 million reported in July. The Draft Cash Flow chart provided a visual representation of the Project Costs along the timeline. (Slide 10)

Discussion and feedback from the Planning Commission was as follows with responses to Commissioner questions as noted:

- Looking at the Draft Cash Flow, the membrane bioreactor (MBR) was the biggest outlay of cash in years. Was the City doing any pro-planning of the funds that would be needed for that?
 - **Mr. Nacrelli** replied that upon completion of this plan and part of next steps, the City planned to do a rate and SDC study within this current budget year to look at the details of how to fund the improvements through a combination of rate adjustments and SDCs, and maybe other mechanisms available.
- Assuming some monies were already in reserve, at what point would the rate and SDC changes need to happen for the monies to be there for the 2028, 2029, 2030 MBR expenditures?

- **Mr. Nacrelli** replied the timing was one of the question the study would have to be able to answer. He suspected rate and SDC increases would be phased in over time, but that would have to be fleshed out in that study, accommodating the growth expected and how those rates would have to be adjusted as growth occurs in order to provide the necessary funding. Once the study and public involvement process were completed, and the fee increases adopted, the new rates would probably have to start right away to make those adjustments.
- How would rate changes for future expansion be explained to existing customers?
 - **Mr. Nacrelli** stated that was ultimately a Council decision. He agreed the majority of the investment was driven by capacity needs; however, some components involved replacing old equipment, so it was not entirely growth driven. He anticipated the impact on SDCs would be far greater than the impact on rates.
- **Mr. Nacrelli** confirmed the improvements would be triggered by threshold population growth; as growth reached a certain place, a new unit gets triggered which provides some flexibility, so the project costs/schedule were not cast in concrete
- Regarding the cost of growth, this was an interesting exercise because in simulating a doubling of the size and the cost tripled, which slows growth because some of the growth occurs because it was competitive price wise. People come to Wilsonville because it was cheaper than Tualatin, for example, and the city has a growth spurt. Growth slows as costs catch up. The schedule was not cast in concrete, growth triggers the decisions for these units to come in.
 - **Mr. Nacrelli** displayed the Capital Planning and Expected Growth – 2045, explaining the numbers in the table on the left were for the orange curve, but the numbers presented in the PowerPoint were based on the purple curve, which was the same growth rate Mr. Price mentioned was used in the 2014 Collection System Master Plan, as well as the Water Treatment Plant Master Plan, and possibly several other planning documents. (Slide 14)
- **Commissioner Mesbah** noted in a previous life, he would be reviewing the Master Plan. A community's Comprehensive Plan was a wish that did not necessarily come true. A cost-effective analysis was needed of some of this projection, growth, and units, especially since by taking this population growth curve, the City had managed to say the only option was the MBR treatment, which was a more expensive treatment, which he understood was to meet higher water quality standards. It was taking away a lot of choices that the City may do well to consider. Maybe the City decides it does not want to double in size—ever—to avoid dealing with higher water quality impacts on city water. These were necessary to explain to rate payers in a comprehensive and understandable way why the City was planning what it was planning. Questions like, “Am I paying for someone else’s growth?” were divisive and not helpful to a sense of community. This was a community service, and it should be approached as a benefit for all and the environment that was receiving the City’s treated waste.
- In terms of the current analysis for flow rates and the details in some of the earlier slides, what baseline population numbers were used as the starting point, 2021 or 2015?
 - **Mr. Price** explained typically 5 to 6 years' worth of data were used, adding this could be considered a 2021 number. When looking at existing data, they often analyzed the flow meter and data being collected from operators at the plant, then they projected out using unit factors and numbers that were conservative to a certain extent, making sure it provided for some flexibility in terms of how the facility was being planned. If the numbers being used were too conservative, and growth did not occur as that particular projection envisioned, then the Plan needed to adjust to that.

- The projected flows made sense, but did the City really expect to be at that 2045 population level to drive all the necessary infrastructure requirements that had been defined. (Slide 14) In July, the projection seemed low and now, was it too high? Was there a middle ground that was a more realistic growth scenario or, if that were to come to pass, would the system's design be done differently from a planning perspective if 45,000 people were expected rather than 52,000.
 - **Mr. Price** responded not necessarily, given the space available at the existing treatment plant site. The City would likely wind up with the same recommendation.
 - **Mr. Nacrelli** noted it might push the timeline further into the future, but to serve the ultimate build out, whether that happened in 2045 or later, there was no more space to do something different.
 - **Mr. Price** agreed, adding they had looked at other options to provide capacity and other processes to intensify secondary treatment, and the conclusion was that the MBR was the direction the City should go no matter the timeline. This was a plan the team believed would provide a very robust facility that the City could feel confident would meet its requirements on the water quality side, while also being flexible to the degree to which it could be made flexible; some additional variations could be added should different criteria or scenarios apply over the next 23 years. At this time, the July and this current proposal bracketed the range of options.
 - **Mr. Nacrelli** stated the Rate and SDC Study would certainly look at how the funding would be impacted by changes in growth. If growth slowed way down for some reason and the projected flows were not achieved, then the City would likely push some of these projects out. To serve the ultimate population within the UGB around Wilsonville with the limited existing site, what would be built would not change, just possibly when things were built.
 - **Mr. Price** noted none of the scenarios accounted for any significant changes on the regulatory side. There were processes in place, underway, or pending to potentially look at other pollutants that might be regulated. This particular plan provided a very firm basis upon which to build, which was why the aeration basin was proposed first as opposed to going right to the membranes. Having that additional volume and capacity in the plant would provide flexibility for the City in the future in being able to address potential future regulatory concerns.
 - He noted that when the membrane facility was in place, the filters and the two secondary clarifiers that are not demolished would effectively become redundant facilities because the MBR would produce **effluent that** would not be necessary to run through clarifiers and filters because of the process of the liquid separation that occurs with the membrane.
 - The membrane facility was chosen due to the site constraints at the treatment plant, but when the facilities are in place, some space would be freed up providing the City with some flexibility in the future should additional regulatory issues arise in addition to the growth.
- **Commissioner Mesbah** said he wanted to clarify his earlier comments. The proposed plan was based on population that was currently baked into the City's plans and would eventually happen, so the projects would be necessary. As long as this plan was based on need and the projects were pushed out if the population growth did not happen, it was a sound plan. The City still needed to explain it very clearly, so it did not create an impression that this was cost for newcomers versus cost for what was not done before, etc. He was unsure whether the fiscal impacts of growth were looked at ahead of planning. Since it was a separate process, it did not get considered when the City adopted new areas to grow into. He suggested doing this kind of thinking before adding areas would be helpful in the overall process.

- **Commissioner Karr** believed the original concern with following the orange line was the fact that the Commission knew of future developments that were going to exceed the orange line. If those developments come to fruition, the orange line was not usable, and that becomes the problem of, "It's an essential service and it has to be in place". Even though there was a timeline, it sounded like the project list would not change, only the timing of the project list and representative costs. He proposed amending the chart on Page 3 to state, "**potential** timeframe based on expected growth" to provide a clearer picture. Since the expenditures for these projects depended upon seeing the anticipated growth, the timeframe should be a little more 'squishy'. (Slide 9)
 - **Mr. Nacrelli** confirmed that whether build out was reached around 2045 or 10 years later, the facilities would still be needed, but perhaps not as soon. (Slide 9)
 - **Chair Heberlein** suggested adding "estimated timeframe" as well as "estimated costs" to clarify there was no hard date.
 - **Mr. Nacrelli** stated that even with the orange population curve, the aeration basin would be done fairly soon.
 - He clarified the first few projects before the aeration basin were not substantial and that the funding for those first few was available, adding the projects were not necessarily even growth projects. (Slide 9)
- The new aeration basin was more growth driven than current population, replace secondary clarifier mechanisms was maintenance, but all the "new" projects were growth-driven. The majority of the estimated cost was growth related and if the timeline was not certain, it would be better to state an estimated timeframe instead of a timeframe which leads people to think a project was certain to happen at that point.
 - **Mr. Nacrelli** agreed that could be presented better and they would make it clear in the document.
- Rather than 'squishy' the project team was encouraged to use 'commensurate to population threshold numbers' and hopefully, the team could show at least a range population levels that would trigger an action, so that it gave some guidance to decision makers.
 - **Mr. Price** agreed including an assumed population column would be helpful.
 - **Mr. Nacrelli** reminded there was a significant element of industrial use in the projections, so population could be a guide, but it was not 100 percent.
- **Commissioner Gallagher** said she fully supported taking care of infrastructure, but she reacted to the projection of growth. Did the City really plan on doubling the population of Wilsonville? Is that what was wanted? Was that what this was all about or was that what the City was concerned about?
 - **Mr. Nacrelli** displayed the City Land use Designations Map, noting most of the service area was mostly already within the city limits. If the available land developed as planned, the projects in the Master Plan was what would be needed, unless there were Zoning or Comprehensive Plan changes.
- The Commissioners discussed where 50,000 people would come from, noting Frog Pond would be 6,000 people. If the study area was based on this Land Use Map boundary, then the population estimates should be based on that boundary as well. Either the boundary or the population estimate was off, as well as what the density would permit.
 - **Mr. Nacrelli** clarified these numbers were consistent with the planning done for the sewer system, as well as the water treatment plant currently under expansion. The numbers were not really a departure from other projections the City had been using to plan for infrastructure.

- As long as it was timebound, or population or use based, then it was okay. This was the plan for infrastructure when Wilsonville needed it, regardless of what the boundary said.
- If the team low balled it and blew the water quality standards because the City was now discharging raw sewage or polluted wastewater, it would penalize the City, and potentially put a total stop to any new growth, etc. until it was addressed. The City did not want to be in that position, which was why planning was done ahead of time.

The Planning Commission took a brief recess, reconvening at 7:48 pm

4. Frog Pond East and South Master Plan (Pauly)

Dan Pauly, Planning Manager, stated this was the Commission's eighth work session on the Frog Pond East and South Master Plan. He introduced the project team and began the PowerPoint presentation, noting tonight's discussion would be around infrastructure, continued discussion on Housing Variety Policy, next steps, and what the finish line looked like at this point.

- He explained the preliminary work done during the 2015 Frog Pond Area Plan provided a foundation for the list of needed infrastructure projects as well as the cost estimates to develop a program for funding them.
- A sensitivity test for a hypothetical higher residential unit count was included in the water and sewer memorandum, and not in the current draft of the transportation memo. During the State administrative rule making for implementation of House Bill 2001, a variety of options was provided that jurisdictions could take, one of which was to plan for 20 units per net acre. How much more expensive would infrastructure be if 20 units per acre were planned versus what the City anticipated would be built during the initial buildout.

Jenna Bogert, Transportation Engineer Consultant, DKS Associates, continued the PowerPoint, highlighting the transportation analysis process and the housing unit and job counts used in the traffic model to identify failing intersections and needed improvements, including for bike and pedestrian facilities. She noted the traffic operations, identified deficiencies, and proposed improvements within the subject area, and described four main intersection improvements, which included roundabouts. (Slide 7) She reviewed the pros and cons of single lane roundabouts, as well as proposed pedestrian and bicycle treatments to address gaps and deficiencies, and the proposed street cross sections on Stafford and Advance Rds.

- **Mr. Pauly** noted the Stafford Rd/65th Avenue intersection was a high-priority project for the County to fix. The team's scenario assumed that those improvements were built within the 2040 baseline being considered. (Slide 6)
- **Ms. Bogert** added City Staff had been informing the County of the changes and plans for the Frog Pond Area throughout the master planning process.

Commissioner comments regarding the transportation infrastructure was as follows with responses to questions by the project team as noted:

- With the Advance Road and 60th roundabout so close to the school and park, what advanced safety precautions beyond the crosswalks would be taken because school children would be crossing there?
 - **Mr. Pauly** replied the project team talked directly with the School District this week on how to plan it. The District likes the roundabout for bus and traffic circulation, having buses go out that



CITY COUNCIL
MONDAY, AUGUST 1, 2022

WORK SESSION

Wastewater Treatment Plant Master Plan (Nacrelli)



CITY COUNCIL MEETING STAFF REPORT

Meeting Date: August 1, 2022		Subject: Wastewater Treatment Plant Master Plan	
		Staff Member: Mike Nacrelli, Senior Civil Engineer	
		Department: Community Development	
Action Required		Advisory Board/Commission Recommendation	
<input type="checkbox"/> Motion <input type="checkbox"/> Public Hearing Date: <input type="checkbox"/> Ordinance 1 st Reading Date: <input type="checkbox"/> Ordinance 2 nd Reading Date: <input type="checkbox"/> Resolution <input checked="" type="checkbox"/> Information or Direction <input type="checkbox"/> Information Only <input type="checkbox"/> Council Direction <input type="checkbox"/> Consent Agenda		<input type="checkbox"/> Approval <input type="checkbox"/> Denial <input type="checkbox"/> None Forwarded <input checked="" type="checkbox"/> Not Applicable	
		Comments: N/A	
Staff Recommendation: Provide input on components of the Wastewater Treatment Plant (WWTP) Master Plan.			
Recommended Language for Motion: N/A			
Project / Issue Relates To:			
<input checked="" type="checkbox"/> Council Goals/Priorities: Align infrastructure plans with sustainable financing resources.	<input type="checkbox"/> Adopted Master Plan(s):	<input type="checkbox"/> Not Applicable	

ISSUE BEFORE COUNCIL:

Provide feedback and input on components of the Wastewater Treatment Plant (WWTP) Master Plan.

EXECUTIVE SUMMARY:

This new City of Wilsonville (City) Wastewater Treatment Plant (WWTP) Master Plan (the Plan) has been developed to satisfy requirements associated with the State of Oregon Department of Environmental Quality (DEQ) guidance document entitled “Preparing Wastewater Planning Documents and Environmental Reports for Public Utilities.” To accommodate future flows and loads, projections were developed based on population projections and referencing WWTP historical data and DEQ wet weather project methodologies. Similarly, to accommodate future water quality regulations, the Plan is adaptive and considers potential future regulatory changes.

The City prepared the Plan with the goal of developing a capital plan that identifies improvements required through the planning period (today through 2045) to comply with requirements of the WWTP National Pollutant Discharge Elimination System (NPDES) permit and potential future regulatory requirements, while accommodating growth identified in the City of Wilsonville Comprehensive Plan (October 2018, updated June 2020). These improvements are designed to provide the best value to the City’s ratepayers by maximizing the use of existing infrastructure and improving system operation while continuing to protect water quality and human health and supporting economic development, consistent with goals and policies contained in the Comprehensive Plan and 2021-2023 City Council Goals.

The City’s WWTP was originally built in 1971 and discharges treated effluent to the Willamette River. The WWTP underwent major upgrades in 2014 to expand the average dry weather capacity to four million gallons per day (mgd) to accommodate the City’s continued growth. The WWTP processes include headworks screening and grit removal facilities, aeration basins, stabilization basins, secondary clarifiers, biosolids processing, cloth filtration, and disinfection processes. Additionally, the City contracts with Jacobs for operation of the wastewater treatment plant, located at 9275 Southwest Tauchman Road.

This Plan identifies improvements taking into consideration:

- The age and condition of existing process equipment and structures,
- Growth in demand for sewer service due to increased population and economic development over the planning period,
- Potential changes to water quality regulations impacting process needs in order to meet effluent limitations and discharge prohibitions imposed by the Oregon Department of Environmental Quality (DEQ), and
- Consistency with the 2018 Comprehensive Plan and City Council 2021-2023 Goals 5, 6 and 7.

WWTP Condition Assessment

Carollo reviewed prior condition assessments performed by others, conducted geotechnical investigations and performed seismic assessments at the WWTP in the course of Plan development.

In 2019, Jacobs Engineering Group Inc. (Jacobs) and Brown and Caldwell both completed condition assessments at the City's WWTP. A total of 322 major assets (per Jacobs' report), including process and mechanical equipment, motors and drives, control panels, generators, instrumentation, and structures, were examined for a variety of conditions that may signify their need for maintenance or replacement.

Seismic Analysis

In 2021, Carollo performed a seismic evaluation and analysis of the City's WWTP as part of the overall plant condition assessment. Because the WWTP was substantially upgraded and expanded in 2014, most of its infrastructure is designed in accordance with the 2010 Oregon Structural Specialty Code (OSSC) and follows modern seismic design and detailing. During Tier 1 evaluations, Carollo identified potential deficiencies and areas for additional investigation. A Tier 1 seismic analysis is an initial evaluation performed to identify any potential deficiencies, whether structural or non-structural, in a building based on the performance of other similar buildings in past earthquakes. Subsequent to the Tier 1 analysis, a more detailed seismic evaluation of five older and potentially seismically vulnerable structures on the WWTP site was conducted. Those structures receiving a more detailed evaluation included the following:

- Operations Building
- Process Gallery
- Workshop
- Aeration Basins and Stabilization Basins
- Sludge Storage Basins and Biofilter

The five potentially vulnerable structures were for an M9.0 Cascadia Seismic Zone (CSZ) earthquake. The M9.0 CSZ is reflective of a catastrophic natural disaster event that has an estimated 35 percent likelihood of occurring within the next 50 years. Following the Tier 1 evaluation, Carollo began Tier 2 evaluations for a select number of identified deficiencies. Although none of the structures showed significant irregularities, the team did identify seismic deficiencies. The recommended seismic retrofits are included in the CIP for the Plan.

Prior to the 2021 seismic evaluation, Carollo's subconsultant, Northwest Geotech, Inc. (NGI), completed a seismic response and geologic hazards assessment of the City's WWTP. Through past and present site investigations and engineering analyses, NGI determined that the native soils beneath the site's granular pit backfill have low risk of liquefaction and its slopes do not pose undue risk. NGI concluded that the WWTP's primary site hazard is the differential settlement that may be caused by soil piping (development of subsurface air-filled voids), which raises the risk of sinkholes forming beneath structures and pipelines. Soil piping usually develops in unsaturated soils when a water source percolates into the ground. While the site is mostly paved and stormwater is being collected, there may be areas where infiltration is occurring next to structures or below pipelines. Recommended actions from NGI to mitigate the risk of soil piping are presented in the Plan.

Wastewater Flow and Load Projections

The Plan evaluates the historical and projected wastewater flows and loads generated in the City of Wilsonville's service area. The load projections include total suspended solids (TSS), biochemical oxygen demand (BOD5), ammonia (NH3), and total phosphorous (TP) loads.

Service area, residential population, industrial contribution, and rainfall records were all considered in the flow and load projection analyses.

Capacity Analysis

Summaries of plant process area capacity assessments and conclusions are presented in the Plan. These assessments focus on the need for improvements or upgrades to existing facilities to address capacity deficiencies identified in the course of Master Plan evaluations.

Regulatory Considerations and Strategy

Several possible regulatory actions by the Oregon DEQ could drive investments in future improvements at the City's WWTP. The plant discharges to the Willamette River and existing and future effluent limitations contained in the NPDES permit dictate, in large part, the necessary treatment processes and configuration at the WWTP necessary to maintain compliance. The existing permit limits for the Wilsonville WWTP are effective September 1, 2020 through July 30, 2025.

Alternative Development and Evaluation

The Plan presents the methodology and findings of a process improvements alternatives evaluation. The plant's treatment process needs were defined by comparing the plant's existing condition, capacity and reliability, with the projected flows, loads, and regulatory constraints for the recommended alternatives. Where capacity deficiencies were predicted, at least two alternatives were analyzed for each corresponding unit process.

EXPECTED RESULTS:

The Plan includes a list of recommended capital improvements, along with an anticipated schedule for completion and preliminary cost estimates. The total estimated amount of capital investment over the planning period is approximately \$31 million, of which \$4.5 million is anticipated in the next 5 years. The recommended capital improvements will provide the basis for an analysis of sewer rates and system development charges (SDCs) that will be necessary to ensure adequate funding to implement to required upgrades.

TIMELINE:

This is the second in a series of presentations to the Planning Commission and City Council. Completed and subsequent planned meetings are as follows:

- Planning Commission Work Session - July 13 (completed)
- City Council Work Session - August 1 (current)
- Planning Commission Public Hearing - September 14
- City Council Public Hearing 1st Reading - October 3
- City Council 2nd Reading - October 17

CURRENT YEAR BUDGET IMPACTS:

The remaining contract balance for finalizing the Plan will carry over into FY 22/23. An additional \$92,450 has been budgeted in FY 22/23 for the Sewer System Rate Study and System Development Charge (SDC) Update, using a combination of Sewer Operating funds and SDCs.

COMMUNITY INVOLVEMENT PROCESS:

A virtual town hall meeting to present the findings of the Plan and solicit public input will be scheduled in August and posted on the City's online calendar. The public hearings listed above will provide additional opportunity for public input. The forthcoming Sewer System Rate Study and SDC Update will also include a robust public engagement process.

POTENTIAL IMPACTS OR BENEFIT TO THE COMMUNITY:

A technically and financially sound plan for providing reliable wastewater treatment, capacity to accommodate future development, and compliance with environmental regulations.

ALTERNATIVES:

The Plan includes alternatives for several of the recommended improvements. The selected alternatives were determined to be the most economically viable. Some of the more capital intensive alternatives can be revisited if necessary due to changing regulatory requirements.

CITY MANAGER COMMENT:

N/A

ATTACHMENT:

1. Draft Wastewater Treatment Plant Executive Summary (dated July 2022)



City of Wilsonville
Wastewater Treatment Plant Master Plan
EXECUTIVE SUMMARY

DRAFT | July 2022



Item B.



City of Wilsonville
Wastewater Treatment Plant Master Plan

EXECUTIVE SUMMARY

DRAFT | July 2022

Item B.

Contents

Executive Summary

ES.1 Planning Area Characteristics	ES-2
ES.2 WWTP Condition Assessment	ES-6
ES.3 Seismic Analysis	ES-6
ES.4 Wastewater Flow and Load Projections	ES-7
ES.5 Capacity Analysis	ES-9
ES.6 Regulatory Considerations and Strategy	ES-15
ES.7 Alternative Development and Evaluation	ES-17
ES.8 Recommended Alternative	ES-20

Tables

Table ES.1	CIP Condition Driven Replacement Projects	ES-6
Table ES.2	Unit Process Capacity Assessment	ES-13
Table ES.3	Unit Process Capacity Year Summary	ES-15
Table ES.4	Current Effluent Permit Limits	ES-16
Table ES.5	Summary of Alternatives	ES-19
Table ES.6	WWTP CIP - Recommended Alternative Opinion of Probable Cost and Phasing	ES-20

Figures

Figure ES.1	Planning Area	ES-3
Figure ES.2	Historical Population and Expected Growth for the City of Wilsonville	ES-5
Figure ES.3	Flow Projection Summary	ES-8
Figure ES.4	Load Projection Summary	ES-9
Figure ES.5	Existing Wilsonville WWTP	ES-11
Figure ES.6	Proposed WWTP Improvements Site Plan	ES-21
Figure ES.7	Projected 20-Year CIP Expenditures	ES-23

Item B.

Abbreviations

AA	average annual
AAF	average annual flow
ABF	average base flow
ADWF	average dry-weather flow
AWWF	average wet weather flow
BCR	biochemical reactor
BOD ₅	biochemical oxygen demand
Carollo	Carollo Engineers, Inc.
CIP	Capital Improvement Plan
City	the City of Wilsonville
CBOD ₅	five-day carbonaceous biochemical oxygen demand
CSZ	Cascadia Seismic Zone
DBO	Design-Build-Operate
DEQ	Department of Environmental Quality
DMR	Discharge Monitoring Reports
ETL	excess thermal load
gpd/sf	gallons per day per square foot
HMI	human-machine interface
Jacobs	Jacobs Engineering Group Inc.
kcal/day	kilocalories per day
lbs	pounds
MBR	membrane bioreactor
mg/L	milligrams per liter
mgd	million gallons per day
MGI	Northwest Geotech, Inc.
ml	milliliter
MLSS	mixed liquor suspended solids
MM	maximum month
MMDWF	maximum month dry weather flow
MMWWF	maximum month wet weather flow
MW	maximum week
MWDWF	maximum month dry weather flow
MWWWF	maximum week wet weather flow
NH ₃	ammonia
No.	number
NPDES	National Pollutant Discharge Elimination System
OSSC	Oregon Structural Specialty Code

PD	peak day
PDDWF	peak day dry weather flow
PDWWF	peak day wet weather flow
PHF	peak hour flow
ppd	pounds per day
PSU PRC	Portland State University Population Research Center
R/C	residential/commercial
SPA	State Point Analysis
SRT	solids residence time
the Plan	Master Plan
TMDL	total maximum daily loads
TP	total phosphorous
TS	total solids
TSS	total suspended solids
TWAS	thickened waste activated sludge
UGB	urban growth boundary
UV	ultraviolet
WWTP	wastewater treatment plant

EXECUTIVE SUMMARY

This new City of Wilsonville (City) Wastewater Treatment Plant (WWTP) Master Plan (the Plan) has been developed to satisfy requirements associated with the State of Oregon Department of Environmental Quality (DEQ) guidance document entitled "Preparing Wastewater Planning Documents and Environmental Reports for Public Utilities." To accommodate future flows and loads, projections were developed based on population projections and referencing WWTP historical data and DEQ wet weather project methodologies. Similarly, to accommodate future water quality regulations, the Plan is adaptive and considers potential future regulatory changes.

The City prepared the Plan with the goal of developing a capital plan that identifies improvements required through the planning period (today through 2045) to comply with requirements of the WWTP National Pollutant Discharge Elimination System (NPDES) permit and potential future regulatory requirements, while accommodating growth identified in the City of Wilsonville Comprehensive Plan (October 2018, updated June 2020 - the 2018 Comprehensive Plan). These improvements are designed to provide the best value to the City's ratepayers by maximizing the use of existing infrastructure and improving system operation while continuing to protect water quality and human health and supporting economic development, consistent with goals and policies contained in the 2018 Comprehensive Plan and 2021-2023 City Council Goals.

The City's WWTP was originally built in 1971 and discharges treated effluent to the Willamette River. The WWTP underwent major upgrades in 2014 to expand the average dry weather capacity to four million gallons per day (mgd) to accommodate the City's continued growth. The WWTP processes include headworks screening and grit removal facilities, aeration basins, stabilization basins, secondary clarifiers, biosolids processing, cloth filtration, and disinfection processes. Additionally, the City contracts with Jacobs for operation of the wastewater treatment plant, located at 9275 Southwest Tauchman Road.

This Plan identifies improvements taking into consideration:

- The age and condition of existing process equipment and structures,
- Growth in demand for sewer service due to increased population and economic development over the planning period,
- Potential changes to water quality regulations impacting process needs in order to meet effluent limitations and discharge prohibitions imposed by the Oregon Department of Environmental Quality (DEQ),
- City of Wilsonville Wastewater Collection System Master Plan (2014, MSA), and

- Consistency with the 2018 Comprehensive Plan and City Council 2021-2023 Goals 5, 6 and 7:
 - Goal 5: Align infrastructure plans with sustainable financing sources.
 - Goal 6: Engage the community to support emergency preparedness and resiliency.
 - Goal 7: Protect Wilsonville's environment and increase access to sustainable lifestyle choices.

ES.1 Planning Area Characteristics

Chapter 1 summarizes the City's wastewater service area characteristics relevant to assessing WWTP facility needs. The planning area considered by this Plan is consistent with the City's 2014 Collection System Master Plan and 2018 Comprehensive Plan including the urban growth boundary (UGB), which is currently the limit of City sewer service as shown in Figure ES 1.

The northern portion of the City of Wilsonville is located within Washington County, and the majority of the City lies in the southwestern part of Clackamas County.

The City sits within the jurisdictional boundaries of Metro, the regional government for the Portland metropolitan area. By state law, Metro is responsible for establishing the Portland metropolitan area's UGB, which includes Wilsonville. Land uses and densities inside the UGB require urban services such as police and fire protection, roads, schools, and water and sewer systems. A figure of the City's existing land use is presented in Chapter 1. Also presented in Chapter 1 are the City's physical characteristics, water resources, and population and employment information, which are all significant factors in planning for wastewater conveyance and treatment facilities.

The Portland State University Population Research Center (PSU PRC) publishes annual estimates of populations for the previous year for cities in Oregon while Metro develops population projections for the future within the Portland metropolitan area, including Wilsonville. The PSU PRC estimated the City’s population as 27,186 in 2021. Metro estimates the City’s population to reach 30,566 people by 2045.

For establishing a per capita basis for flow and load projections for the Plan, certified PSU PRC historical population estimates were used for 2015 through 2019. Metro’s future population forecasts were used for 2020 through 2045. Figure ES.2 shows the historical population and future growth predicted for the City. Figure ES.2 also identifies growth projections developed to allow the City to assess capital requirements possibly resulting from more aggressive growth than projected by Metro. Analysis of possible growth scenarios is described in greater detail in Chapter 4.

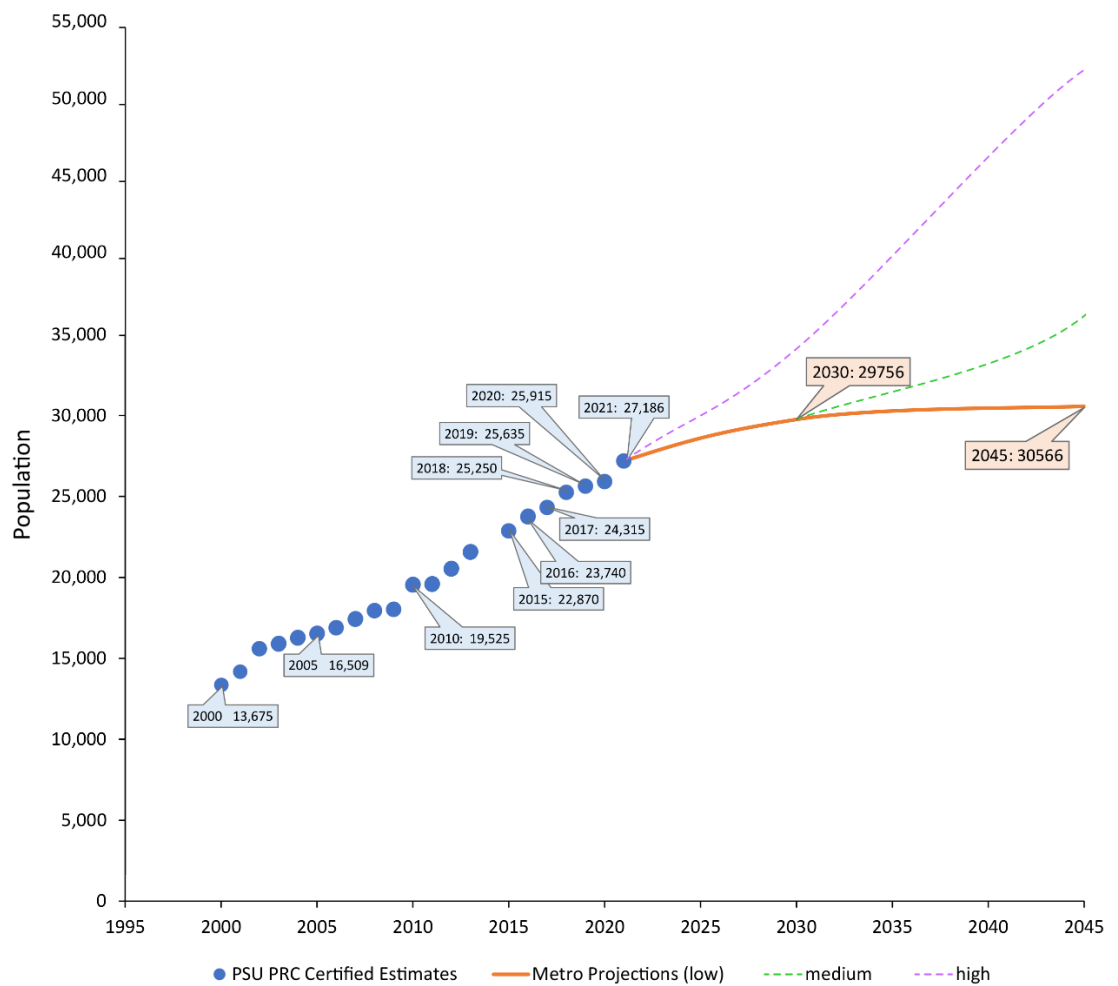

Figure ES.2 Historical Population and Expected Growth for the City of Wilsonville

ES.2 WWTP Condition Assessment

Carollo Engineers, Inc. (Carollo) reviewed prior condition assessments performed by others, conducted geotechnical investigations and performed seismic assessments at the WWTP in the course of Plan development.

In 2019, Jacobs Engineering Group Inc. (Jacobs) and Brown and Caldwell both completed condition assessments at the City's WWTP. A total of 322 major assets (per Jacobs' report), including process and mechanical equipment, motors and drives, control panels, generators, instrumentation, and structures, were examined for a variety of conditions that may signify their need for maintenance or replacement. Chapter 2 presents a summary of critical assets that require short term rehabilitation or replacement, as well as a list of assets that are less critical to operations, or have minor condition issues, but may be included in a short-term improvements project or a task order for Jacobs operations personnel. Table ES.1 displays the condition driven rehabilitation or replacement projects from Chapter 2 that were included in the recommended Capital Improvement Plan (CIP) in Chapter 7.

Table ES.1 CIP Condition Driven Replacement Projects

Asset	Description
Trojan UV 4000 System	While only used as a backup to the Ozonia UV system, the Trojan system's HMI has errors that prevent it from showing the status of the lamps in module 3. Since it is used infrequently, the system's condition is largely unknown. After review of the 2019 condition assessment reports and discussion with the City and Jacobs staff, it was concluded that the UV 4000 unit must be replaced.
Secondary Clarifiers No. 1 and No. 2	Ovivo completed a field review of the plant's secondary clarifiers No. 1 and No. 2 in April 2022. Although both units were operational, repairs were identified to improve the operation of the clarifiers. The recommended repairs include drive controls for both units, new skimmers for both units, squeegees for both tanks rake arms, EDI chains, one motor and reducer assembly, one skimmer arm assembly, and new secondary clarifier mechanisms. ⁽¹⁾

Notes:

(1) The detailed Ovivo Field Service Report is included in [Appendix X](#).

Abbreviations: HMI - human-machine interface; No. - number; UV - ultraviolet.

ES.3 Seismic Analysis

In 2021, Carollo performed a seismic evaluation and analysis of the City's WWTP as part of the overall plant condition assessment. Because the WWTP was substantially upgraded and expanded in 2014, most of its infrastructure is designed in accordance with the 2010 Oregon Structural Specialty Code (OSSC) and follows modern seismic design and detailing. During Tier 1 evaluations, Carollo identified potential deficiencies and areas for additional investigation. A Tier 1 seismic analysis is an initial evaluation performed to identify any potential deficiencies, whether structural or non-structural, in a building based on the performance of other similar buildings in past earthquakes. Subsequent to the Tier 1 analysis, a more detailed seismic

evaluation of five older and potentially seismically vulnerable structures on the WWTP site was conducted. Those structures receiving a more detailed evaluation included the following:

- Operations Building.
- Process Gallery.
- Workshop.
- Aeration Basins and Stabilization Basins.
- Sludge Storage Basins and Biofilter.

The five potentially vulnerable structures were compared against an S-4 Limited Safety structural performance level and N-B Position Retention non-structural performance level for an M9.0 Cascadia Seismic Zone (CSZ) earthquake. The M9.0 CSZ is reflective of a catastrophic natural disaster event that has an estimated 35 percent likelihood of occurring within the next 50 years. Following the Tier 1 evaluation, Carollo began Tier 2 evaluations for a select number of identified deficiencies. Although none of the structures showed significant irregularities, the team did identify seismic deficiencies. The recommended seismic retrofits are included in the CIP for this Plan.

Prior to the 2021 seismic evaluation, Carollo's subconsultant, Northwest Geotech, Inc. (NGI), completed a seismic response and geologic hazards assessment of the City's WWTP. Through past and present site investigations and engineering analyses, NGI determined that the native soils beneath the site's granular pit backfill have low risk of liquefaction and its slopes do not pose undue risk. NGI concluded that the WWTP's primary site hazard is the differential settlement that may be caused by soil piping (development of subsurface air-filled voids), which raises the risk of sinkholes forming beneath structures and pipelines. Soil piping usually develops in unsaturated soils when a water source percolates into the ground. While the site is mostly paved and stormwater is being collected, there may be areas where infiltration is occurring next to structures or below pipelines. Recommended actions from NGI to mitigate the risk of soil piping are presented in Chapter 2.

ES.4 Wastewater Flow and Load Projections

Chapter 3 of the Plan evaluates the historical and projected wastewater flows and loads generated in the City of Wilsonville's service area. The load projections include total suspended solids (TSS), biochemical oxygen demand (BOD₅), ammonia (NH₃), and total phosphorous (TP) loads.

Service area, residential population, industrial contribution, and rainfall records were all considered in the flow and load projection analyses. Facility planning involves estimating rates of growth in wastewater generation within the service area which are unlikely to align precisely with the actual growth observed. During the planning period, City staff will need to assess service area growth at regular intervals and revisit the analysis presented in this Plan. A determination will need to be made whether projected flows and loads (which drive assessments of unit process capacity) are aligned with calendar projections presented in this plan and consider if conclusions presented regarding capacity and timing of recommended improvements remain valid. If not, adjustments to the plan will need to be undertaken to ensure sufficient capacity remains available to serve anticipated growth.

Analysis of flow projections were completed through two different methods: (1) analysis of historical plant records and (2) DEQ Guidelines for Making Wet-Weather and Peak Flow Projections for Sewage Treatment in Western Oregon, which is referred to as the DEQ methodology in this Plan. Since there is no DEQ methodology for load analysis, all projections were developed based on historical plant records. Figure ES.3 summarizes the measured and projected maximum month, peak day and peak hour flows. The projections for the remaining flow elements can be found in Chapter 3.

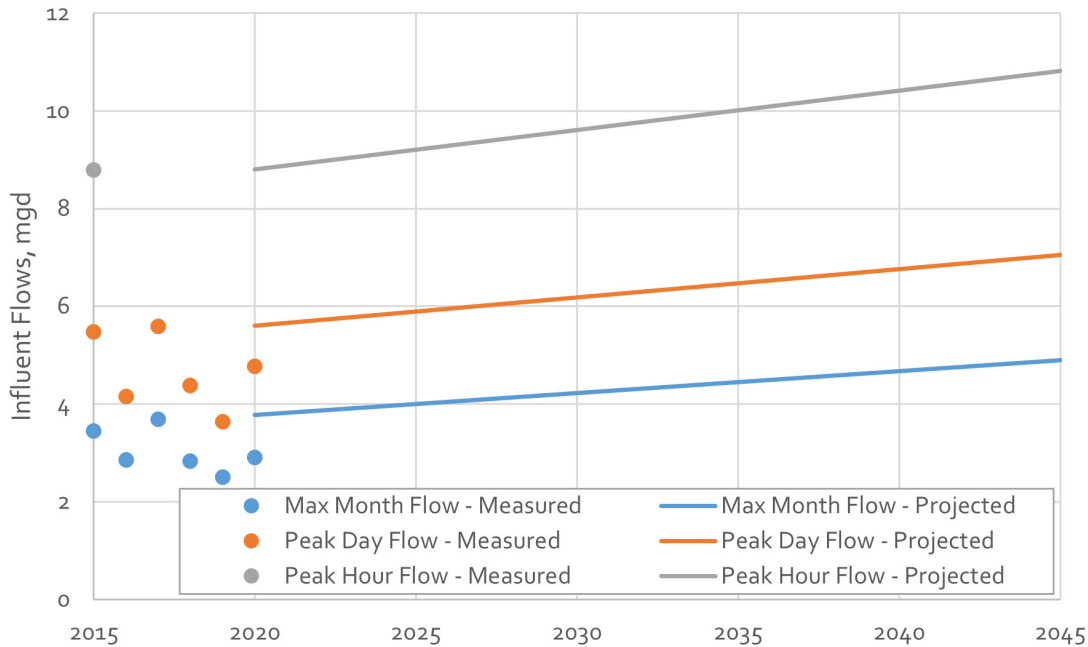

Figure ES.3 Flow Projection Summary

Load projections were calculated for influent TSS, BOD₅, NH₃, and TP. Figure ES.4 summarizes the measured and projected influent maximum month BOD and TSS loads. The projections for the remaining load elements can be found in Chapter 3.

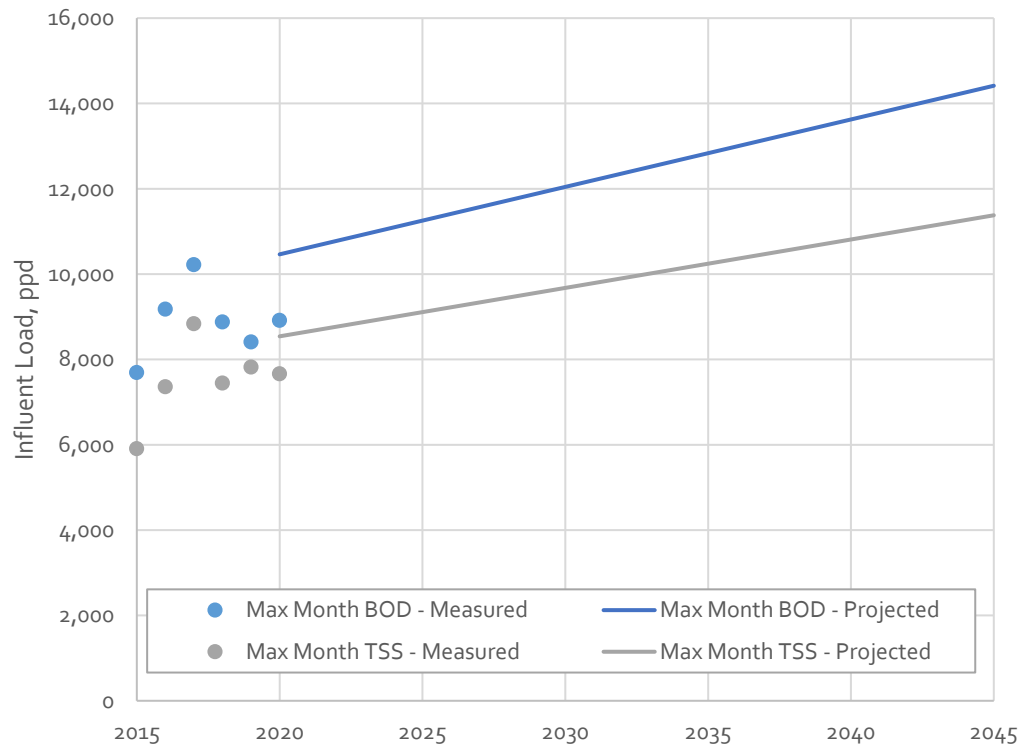

Figure ES.4 Load Projection Summary

The projected flows and loads developed in Chapter 3 were compared against the rated capacity for each of the WWTP's unit processes to determine whether expansion would be required within the planning period. The findings of this capacity analysis are discussed in the next section.

ES.5 Capacity Analysis

Summaries of plant process area capacity assessments and conclusions are presented in this Plan. These assessments focus on the need for improvements or upgrades to existing facilities to address capacity deficiencies identified in the course of Master Plan evaluations. A site plan of the City's existing WWTP is presented in Figure ES.5.

Chapter 4 identifies existing capacity ratings and deficiencies for the liquid and solids stream treatment processes at the City's WWTP. Analyses are based on operational practices in place at the time and existing effluent limits established by the WWTP's National Pollutant Discharge Elimination System (NPDES) permit. Biological process modeling was performed using BioWin version 6.2 to predict plant performance under current and future flow and loading conditions to assess when unit process capacities may be exceeded within the planning period (present through 2045).

A summary of the capacity assessment completed and presented in Chapter 4 is detailed below in Table ES.2.

Item B.



- LEGEND:**
- 1 - DEWATERING & DRYING BUILDING
 - 2 - PROCESS GALLERY
 - 3 - SECONDARY CLARIFIER NO. 1
 - 4 - SECONDARY CLARIFIER NO. 2
 - 5 - UV DISINFECTION SYSTEM
 - 6 - WORKSHOP
 - 7 - SECONDARY PROCESS FACILITY
 - 8 - STABILIZATION BASIN
 - 9 - SLUDGE STORAGE BASINS AND BIOFILTERS
 - 10 - HEADWORKS
 - 11 - DISK FILTERS
 - 12 - COOLING TOWERS
 - 13 - W3 REUSE PUMP STATION
 - 14 - OPERATIONS BUILDING
 - 15 - SITE ENTRANCE

Plot Date: 6/28/2022 9:15:35 AM

FILE NAME: 11962A00_FIGURE_SEED.DWG

LAST SAVED BY: bhawes

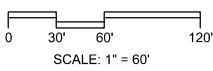

Figure ES.5
EXISTING WILSONVILLE WWTP
 CITY OF WILSONVILLE



Item B.

Table ES.2 Unit Process Capacity Assessment

Unit Process	Capacity Assessment
Preliminary Treatment	
Screening	There is sufficient hydraulic capacity for both mechanical screens to accommodate the projected 2045 PHF.
Grit Removal	Capacity is adequate for providing full treatment of the projected 2045 PHF.
Secondary Treatment	
Secondary Treatment	Based on maximum week MLSS predicted from BioWin modeling at peak day flow with all clarifiers in service (and assuming a 5-day SRT), there is only sufficient capacity through 2038.
Secondary Clarifiers	The secondary clarifiers are expected to stay under the maximum hydraulic loading criteria for the entirety of the planning period.
Aeration Blowers	The air demands of the secondary treatment process are projected to exceed the firm capacity of the aeration blowers under peak conditions by 2035.
Tertiary Treatment and Disinfection	
Disk Filters	The existing disk filter capacity is expected to be exceeded by 2037 with one unit out of service or in backwash mode based on effluent limitations included in the City's DBO Contract with Jacobs. At this time the City expects to relax these contract limitations rather than invest in additional capacity.
Secondary Effluent Cooling Towers	It is not expected that the total hydraulic capacity of the cooling towers will be exceeded by 2045.
UV Disinfection	The existing UV channels are adequately sized to fully disinfect the 2045 PHF with all units in service, as well as the PDDWF with one channel out of service. The City currently has an older UV unit in place as an emergency backup to the primary system. That backup unit is aging and the City plans replacement during the planning period.
Outfall	Even with the Willamette River at its 100-year flood elevation, it is expected that the outfall pipeline can accommodate approximately 19 mgd before the UV channel effluent weirs are at risk of submergence upstream. Since this flow is well above the hydraulic capacity of the rest of the plant, no expansion will be needed until after 2045. ⁽¹⁾
Solids Handling	
Gravity Belt Thickener	The capacity analysis results indicate adequate for thickening the current and projected maximum week WAS loads with one unit out of service.
TWAS Storage	The TWAS storage volume is sufficient to accommodate the expected maximum week solids loads for three days (assuming TWAS is thickened to 4 percent).
Dewatering Centrifuges	The rated capacity of the current centrifuges is sufficient to process the maximum week load with one unit out of service through 2045 assuming operating times of 24 hours per day for 5 days per week, per the criteria detailed in Chapter 4. ⁽²⁾
Biosolids Dryer and Solids Disposal	The capacity of the biosolids dryer is adequate for handling the current and projected max week solids loads (in year 2045) on the basis of its design evaporation rate, assuming dewatered cake is dried from 20 percent TS to 92 percent TS and the dryer is operated for 24 hour per day for 5 days per week. ⁽³⁾

Notes:

- (1) The existing outfall was recently modified and equipped with five parallel diffuser pipes equipped with duckbill check valves to improve the mixing zone characteristics in the Willamette River.
- (2) The centrifuges have exhibited inconsistent performance in recent months. The City recently refurbished these units and expects they will provide sufficient capacity through 2045.
- (3) The existing solids dryer has sufficient capacity through 2045 but has exhibited inconsistent performance. See Alternative 2B, Chapter 6.

Abbreviations: DBO - Design-Build-Operate; gpd/sf - gallons per day per square foot; MLSS - mixed liquor suspended solids; SPA - State Point Analysis; SRT - solids residence time; TS - total solids; TWAS - thickened waste activated sludge.

Item B.

Table ES.3 further summarizes the capacity assessment by listing each unit process, associated design parameters and year of possible capacity exceedance.

Table ES.3 Unit Process Capacity Year Summary

Unit Process	Design Parameter	Redundancy Criteria ⁽³⁾	Year of Capacity Exceedance
Influent Screening	PHF	One mechanical screen out of service	>2045
Grit Chamber	PHF	All units in service	>2045
Secondary Treatment	MW MLSS inventory at PDF	All units in service	2038
Aeration Blowers	Peak BOD Load	Largest unit out of service	2035
Secondary Effluent Cooling Towers	June 1 - Sept 30 PDF	All units in service	>2045
Disk Filters	MWDWF	One unit in backwash	2037⁽¹⁾
UV Disinfection Channels	PHF	All units in service	>2045
Outfall	PHF	-	>2045
Gravity Belt Thickening	MW Load	One unit out of service	>2045
TWAS Storage	MW Load	All units in service	>2045
Dewatering Centrifuges	MW Load	One unit out of service	>2045 ⁽²⁾
Biosolids Dryer	MW Load	All units in service	>2045 ⁽²⁾

Notes:

Unit processes in white are projected to run out of capacity before year 2045.

- (1) Existing Disk Filters are predicted to exceed reliable capacity (one unit out of service) in 2037 based on vendor provided design criteria. This conclusion assumes limitations for effluent total suspended solids contained in the WWTP DBO contract, which are far more stringent than the City's NPDES permit.
- (2) As noted previously, the existing centrifuges and biosolids dryer appear to have sufficient capacity through the planning year 2045, however condition and age are likely to require replacement during the planning period. It is recommended the City reassess available replacement technologies prior to replacement and consider loading appropriate to the planning horizon of any new units selected.
- (3) Reference [Appendix D](#) - Reliability requirements, Preparing Wastewater Planning Documents and Environmental Reports for Public Utilities, OR DEQ, 2018, Revised July 2019

ES.6 Regulatory Considerations and Strategy

It is the responsibility of the Oregon Department of Environmental Quality (DEQ) to establish and enforce water quality standards that ensure the Willamette River's beneficial uses are preserved. Discharges from wastewater treatment plants are regulated through the National Pollutant Discharge Elimination System (NPDES). All discharges of treated wastewater to a receiving stream must comply with the conditions of an NPDES permit. The Wilsonville WWTP discharges to the Willamette River at River Mile 38.5 just upstream of the Interstate 5 bridge. The existing permit limits for the Wilsonville WWTP are shown in Table ES.4. This permit became effective on September 1, 2020 and expires July 30, 2025.

Table ES.4 Current Effluent Permit Limits

Parameter	Average Effluent Concentrations		Monthly Average, (ppd)	Weekly Average, (ppd)	Daily Maximum, (lbs)
	Monthly	Weekly			
May 1 - October 31					
CBOD ₅	10 mg/L	15 mg/L	190	280	380
TSS	10 mg/L	15 mg/L	190	280	380
November 1 - April 30					
BOD ₅	30 mg/L	45 mg/L	560	840	1100
TSS	30 mg/L	45 mg/L	560	840	1100
Other Parameters Limitations					
E. coli Bacteria	<ul style="list-style-type: none"> Shall not exceed 126 organisms per 100 ml monthly geometric mean. No single sample shall exceed 406 organisms per 100 ml. 				
pH	<ul style="list-style-type: none"> Instantaneous limit between a daily minimum of 6.0 and a daily maximum of 9.0 				
BOD ₅ Removal Efficiency	<ul style="list-style-type: none"> Shall not be less than 85% monthly average 				
TSS Removal Efficiency	<ul style="list-style-type: none"> Shall not be less than 85% monthly average 				
ETL June 1 through September 30	<ul style="list-style-type: none"> Option A: 39 million kcal/day 7-day rolling average Option B: Calculate the daily ETL limit 				

Notes:

Abbreviations: CBOD₅ - five-day carbonaceous biochemical oxygen demand; ETL - excess thermal load; kcal/day - kilocalories per day; lbs - pounds, mg/L - milligrams per liter; ml - milliliter.

The WWTP has been compliant with NPDES permit limits, generally. However due to construction issues that required that aeration basins be offline, equipment failure and issues with solids processing, the WWTP did violate their NPDES permit over eight months between 2015 and 2020 (December 2015, February 2017, April 2017, January 2018, August 2018, May 2020, June 2020 and July 2020). Most of these violations were due to the daily effluent TSS load exceeding the maximum daily load limit in the NPDES permit. It is anticipated that once the issues with solids processing are addressed, the City's current treatment process will be able to meet permit limits.

Chapter 5 details potential regulatory issues the City will need to take into consideration in coming years. Several possible regulatory actions by the Oregon DEQ could drive investments in future improvements at the City's WWTP. The plant discharges to the Willamette River and existing and future effluent limitations contained in the NPDES permit dictate, in large part, the necessary treatment processes and configuration at the WWTP necessary to maintain compliance.

Future treatment upgrades may be required when DEQ establishes total maximum daily loads (TMDL) for the lower Willamette River. Dissolved oxygen and nutrient limits, such as phosphorus limitations, are possible. The dissolved oxygen in the lower part of the river does not always meet water quality standards, and indications of excessive nutrients, such as chlorophyll-a, aquatic weeds, and harmful algal blooms, are present in the lower Willamette River. DEQ has

begun its triennial review of Oregon's water quality criteria. The review could result in more stringent or new discharge requirements, but this process will take several years. For planning purposes, providing plant footprint to accommodate future treatment to remove phosphorus and address dry weather seasonal limits on dissolved oxygen should be anticipated. In addition, the City should continue to engage with DEQ regarding any proposed receiving water temperature regulatory actions.

ES.7 Alternative Development and Evaluation

Chapter 6 presents the methodology and findings of a process improvements alternatives evaluation. The plant's treatment process needs were defined by comparing the plant's existing condition, capacity and reliability, with the projected flows, loads, and regulatory constraints for the recommended alternatives. Where capacity deficiencies were predicted, at least two alternatives were analyzed for each corresponding unit process. Process modifications associated with each alternative were modeled in BioWin using a calibrated model to evaluate the overall impact on plant operations.

As identified in Chapter 4, the secondary treatment process is expected to require additional capacity during the planning horizon (2045). Chapter 6 details two alternatives to address these capacity limitations. The two alternatives considered to increase secondary capacity are:

1. Expansion of the existing conventional activated sludge process; and
2. Intensification of the existing treatment process using membrane bioreactor (MBR) technology.

Due to the higher capital and operating costs of intensification, construction of a new conventional aeration basin is recommended to increase secondary capacity. As flows and loads increase, or regulatory requirements become more stringent, it may be necessary to intensify treatment. It is recommended the City revisit this evaluation as the need for 1) additional capacity to accommodate growth nears or 2) more stringent effluent limitations are considered. This offers the opportunity to take advantage of potential advances in technology as well as confirming the predicted time frame of capacity exceedance. A new aeration basin project is included in the Capital Improvement Plan in Chapter 7.

The existing aeration blower system firm capacity is expected to be deficient by 2035. An additional aeration blower (same size and design air flow rate as the existing high-speed turbo blowers) would ensure there is sufficient blower capacity through the end of the planning period to meet current permit requirements. There is adequate space to add a fourth turbo blower to the same discharge header pipe as the existing turbo blowers. Additionally, intensification of the secondary treatment process would further increase the aeration demands because operating at a higher MLSS reduces oxygen transfer efficiency in the aeration basins. If intensification is reconsidered and selected for the planning period, or if nutrient limits are imposed within the planning period that requires intensification or operation at a higher MLSS, the blower air demands should be revisited.

Additional tertiary filtration capacity is predicted to be needed before 2045 to provide full treatment of the MWDWF with one disc filter out of service or in backwash mode. After discussions with the City, two alternatives were identified to increase capacity:

1. Increase filtration capacity, and
2. Modify the requirement in the WWTP DBO contract to relax effluent limitations which are currently more stringent than those contained in the City's NPDES permit.

The City's WWTP NPDES permit currently requires effluent to contain less than 10 mg/L TSS during the dry season (see Table ES.8). However, the DBO firm's contract with the City requires an effluent TSS of less than five mg/L, or half of the WWTP's permitted effluent quality. At this time, the City has decided to study the performance of the existing tertiary filters over time and expects to relax effluent TSS requirements in the DBO contract unless actual water quality impacts (exceedances of permit limitations) are realized. The City will also consider the option of new technologies for filtration, noting that if the City selected an intensification technology utilizing membranes, this may potentially eliminate tertiary filtration capacity concerns.

While the capacity assessment findings presented in Chapter 4 determined existing solids dewatering centrifuges have sufficient capacity, the remaining equipment service life may require replacement within the planning horizon. The centrifuges, installed in 2014, were recently refurbished, but by 2045, will have been in service for over 30 years. The City should plan for their replacement within the planning horizon and consider whether a capacity increase is needed at the time of replacement based on projections of solids production and processing needs. Additionally, the secondary process was modified in 2020 and has experienced extended periods where mixed liquor concentrations have been elevated above typical ranges for conventional activated sludge or extended aeration processes. Due to the complications with secondary process operation and performance issues with the centrifuges, it is recommended the City study the secondary treatment and dewatering processes to confirm that the assumptions and conclusions regarding centrifuge capacity in Chapter 4 may be relied upon. A dewatering performance optimization study is recommended so the City can collect and analyze secondary treatment and solids processing performance data. For budgeting purposes, an opinion of probable cost for replacing the existing centrifuges is provided in Chapter 7. Timing of that equipment replacement will depend on performance of the existing units, future loading assumptions, and observed condition.

The existing solids dryer has experienced operational issues in recent years, including a fire that caused extensive damage to the equipment in April 2019 and a leaking rotary joint and damaged seal in 2021. As of February 25, 2022, the dryer has been repaired and is operating. Because of the City's commitment to solids drying as the preferred process to achieve Class A biosolids, the alternatives evaluation presented in this Plan for future dryer replacement was conducted with a focus on thermal drying options only.

Chapter 6 details an analysis of the following alternatives to improve the drying system:

1. Alternative 1 - Continue operating the existing biochemical reactor (BCR) paddle dryer and defer replacement.
2. Alternative 2 - Modify the existing Dewatering and Drying Building to accommodate a different solids dryer technology or a redundant dryer.
3. Alternative 3 - Construct a new dryer building with a different solids dryer technology.

While it is anticipated the existing dryer has useful life through at least 2026 (current DBO contract expiration), by 2031 the dryer will have been in operation for over 15 years. It is recommended the planning and design of upgrades to provide reliable dryer capacity begin in 2029, or sooner if further operational concerns arise. The City has indicated a preference for a variation of Alternative 2 which involves expanding the existing Dewatering and Drying Building to accommodate a second solids paddle dryer. This alternative provides backup capacity to allow the City to continue delivering Class A solids during periods of downtime if a mechanical failure occurs or to accommodate regular maintenance of one dryer train. As mentioned previously, this Plan recommends the City complete a study of the secondary sludge quality, performance of that process, chemical addition types and locations, and solids handling process performance overall prior to making a final selection of the preferred dryer alternative from the alternatives detailed in Chapter 6. For purposes of capital planning, this Plan assumes the City will implement Alternative 2b (modification of Dewatering and Drying Building to accommodate a second paddle dryer) with a study and confirmation of this selection beginning in 2029.

Lastly, the City wants to establish a direct connection between the City's fiber optics network and the WWTP. This addition consists of routing two new conduits (one spare) and fiber optic cabling from the WWTP's Operations Building to the site entrance, where the conduits will be tied into the City's fiber optics network. Chapter 6 details one potential routing from the Operations Building to the site entrance that would minimize impact to existing yard utilities. The fiber optic cable addition is included in Chapter 7 and the City's 5-year CIP.

Table ES.5 below summarizes the alternatives evaluated in Chapter 6 including recommendations for future WWTP improvements.

Table ES.5 Summary of Alternatives

Unit Process	Alternatives Considered	Selected Alternative
Secondary Treatment	<ul style="list-style-type: none"> Expansion of the existing conventional activated sludge process. Intensification of the existing treatment process. 	<ul style="list-style-type: none"> Expansion of the existing conventional activated sludge process through the addition of another aeration basin.
Tertiary Treatment	<ul style="list-style-type: none"> Increase filtration capacity. Eliminate the requirement on the DBO firm to meet effluent limits more stringent than the NPDES permit. 	<ul style="list-style-type: none"> Eliminate the requirement on the DBO firm to meet effluent limits more stringent than the NPDES permit.
Solids Dryer	<ul style="list-style-type: none"> Continue operating the existing BCR paddle dryer and defer replacements. Modify the existing Dewatering and Drying Building to accommodate a different solids dryer technology or a redundant dryer. Construct a new dryer building with a different solids dryer technology. 	<ul style="list-style-type: none"> Modify the existing Dewatering and Drying Building to accommodate a different solids dryer technology or a redundant dryer by expanding the Dewatering and Drying Building to accommodate a second solids paddle dryer.

ES.8 Recommended Alternative

Figure ES.6 presents a WWTP site plan identifying locations of recommended improvements resulting from condition and capacity assessments, including evaluation of alternatives, as described.

Summaries of opinions of probable costs and anticipated phasing for the improvements recommended for inclusion in the City's WWTP CIP are provided in Table ES.6.

The expected cash flow for the planning period was determined for the recommended improvements summarized in Table ES.6. The cash flow through 2045 includes an escalation rate of three percent, and the estimated peak expenditure for any fiscal year is approximately \$13,906,000 in fiscal year 2031. The projected CIP expenditures are presented in Figure ES.7.

Table ES.6 WWTP CIP - Recommended Alternative Opinion of Probable Cost and Phasing

Plant Area	Project ⁽¹⁾	Opinion of Probable Cost	Approximate Year Online
Solids Handling	Dewatering Performance Optimization	\$150,000	2023
Communications/IT	Fiber Optic Cable Addition	\$55,000	2023
UV System	Trojan 4000 UV System Improvement	\$1,650,000	2024
Support Buildings	Seismic Improvements	\$1,015,000	2024
Secondary Treatment	New Secondary Clarifier Mechanisms	\$1,665,000	2026
Solids Handling	Solids Dryer Improvement	\$16,100,000 ⁽⁶⁾	2031
Solids Handling	Existing Centrifuge Replacement	\$2,200,000 ^(3,5)	2033 ⁽⁴⁾
Secondary Treatment	New Aeration Blower	\$394,000	2035
Secondary Treatment	New Conventional Aeration Basin	\$7,895,000	2038
TOTAL		\$31,124,000	

Notes:

White rows indicate projects that are in the City's 5-year CIP and blue rows indicate projects that are outside the 5-year CIP window.

- (1) Details of each project can be found in Chapter 2 or Chapter 6 of this Master Plan.
- (2) The estimated opinion of probable costs include the construction costs plus Engineering, legal and administration fees (ELA, or soft costs). Details on the estimated project costs can be found in Chapter 2 or Chapter 6 of the plan, with the exception of costs for the backup UV system and centrifuges which are presented earlier in Chapter 7.
- (3) For budgeting purposes, the Option B centrifuge cost from Table 7.4 is used for the project cost summary and the CIP
- (4) Replacement timing dependent upon satisfactory equipment performance
- (5) The centrifuges installed with the City's 2014 upgrade project have exhibited inconsistent performance in recent months. The City recently refurbished these units and expects they will provide sufficient capacity through 2045. However, by that time, the units will have been in service for over 30 years. It is recommended the City plan for replacement of these units during the planning horizon of this Master Plan. Assuming replacement occurs in the mid-2030's the City should reassess capacity needs of those units beyond the 2045 horizon, consistent with the expected service life of the new equipment.
- (6) The existing solids dryer has sufficient capacity through 2045. As with the dewatering centrifuges, the dryer equipment will soon have been in operation for a decade. It is recommended the City plan for replacement of the dryer during the planning horizon of this Master Plan. The City plans to replace the existing dryer with a new piece of equipment using similar technology and potentially rehabilitate the existing unit to serve as a backup. See Alternative 2B, Chapter 6.

Capital costs estimated in the Plan will be considered as the City assesses the need to adjust sewer enterprise rates and charges in coming months. It will be important to distinguish capacity and condition (repair and replacement) driven improvements in assigning costs to existing rate payers and future users.

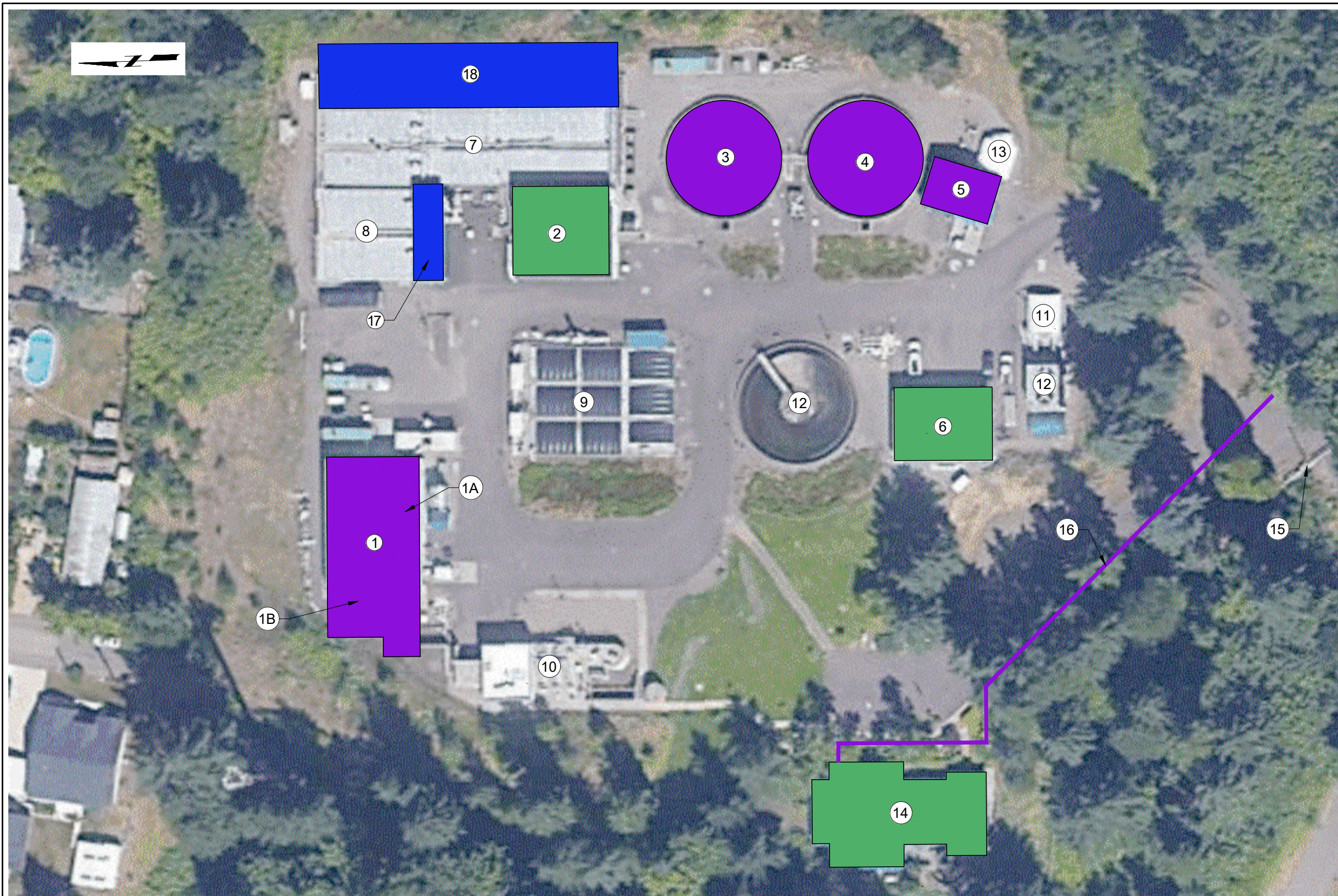

LEGEND:

- CONDITION OR ADDITION PROJECTS** ■
- 1 - DEWATERING & DRYING BUILDING
- 1A - EXISTING CENTRIFUGE REPLACEMENT
- 1B - SOLIDS DRYER IMPROVEMENT
- 3 - SECONDARY CLARIFIER NO. 1 - REPLACE MECHANISMS
- 4 - SECONDARY CLARIFIER NO. 2 - REPLACE MECHANISMS
- 5 - STANDBY UV SYSTEM REPLACEMENT
- 16 - FIBER OPTIC CABLE ADDITION
- CAPACITY PROJECTS** ■
- 17 - NEW AERATION BLOWER
- 18 - NEW AERATION BASIN NO. 3, ACCESS IMPROVEMENTS & GRADING
- SEISMIC RETROFIT PROJECTS** ■
- 2 - PROCESS GALLERY
- 6 - WORKSHOP
- 14 - OPERATIONS BUILDING
- OTHER FACILITIES**
- 7 - SECONDARY PROCESS FACILITY
- 8 - STABILIZATION BASIN
- 9 - SLUDGE STORAGE BASINS AND BIOFILTERS
- 12 - SECONDARY CLARIFIER NO. 3
- 10 - HEADWORKS
- 11 - DISK FILTERS
- 12 - COOLING TOWERS
- 13 - W3 REUSE PUMP STATION
- 15 - SITE ENTRANCE

Plot Date: 6/3/2022 1:45:48 PM

FILE NAME: 11962A00_FIGURE_SEED.DWG

LAST SAVED BY: bhawes

0 30' 60' 120'
SCALE: 1" = 60'

Figure ES.6
PROPOSED WILSONVILLE WWTP IMPROVEMENTS
CITY OF WILSONVILLE

Item B.

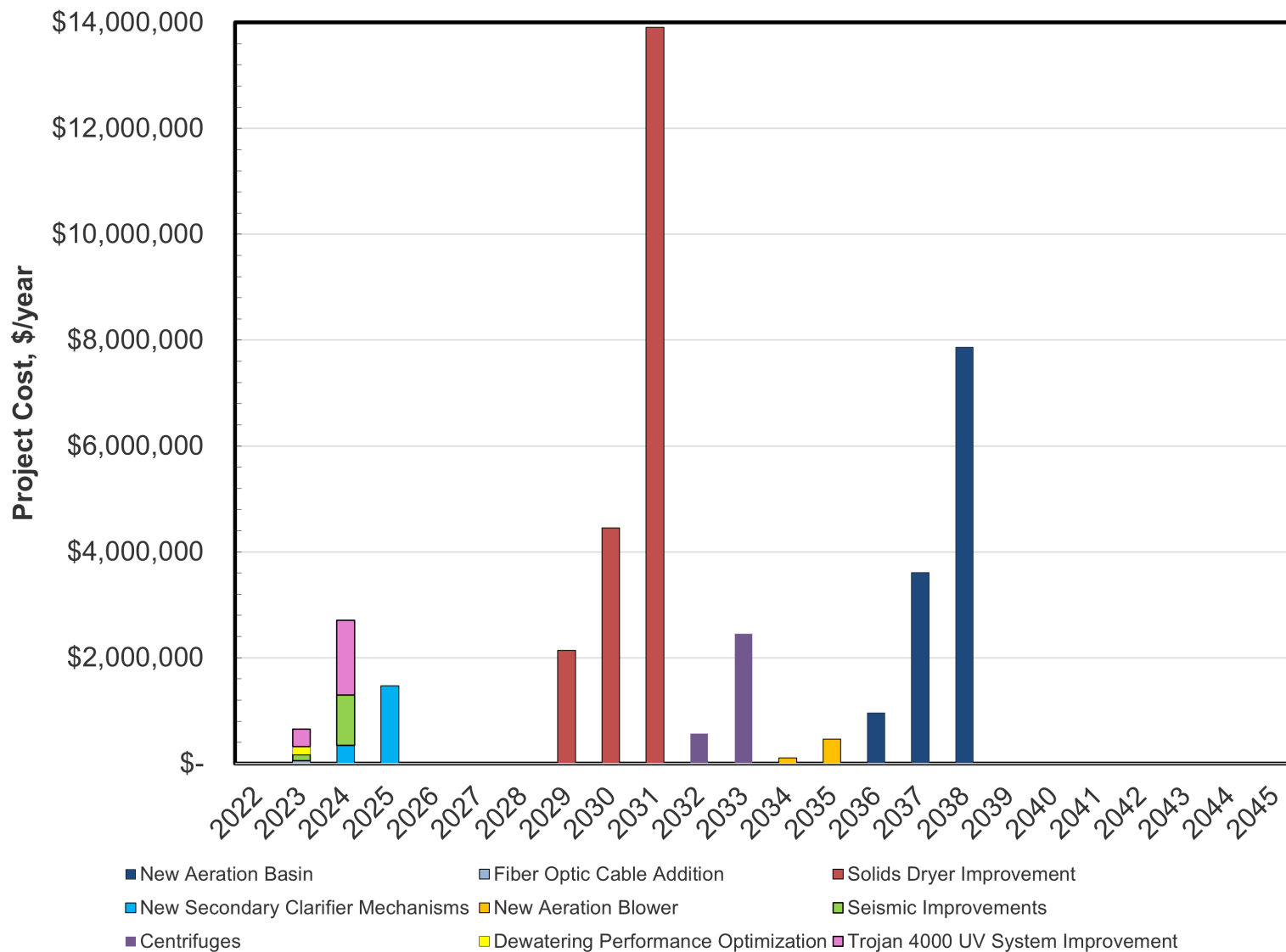

Figure ES.7 Projected 20-Year CIP Expenditures

City of Wilsonville Wastewater Treatment Plant Master Plan

City Council Work Session

August 1, 2022



Introduction



Presenters:

Mike Nacrelli, PE, Senior Civil Engineer

Dave Price, PE, Carollo Engineers

Master Plan Drivers



- City Capital Planning
- Accommodating Expected Growth
- Addressing Asset Condition and Replacement needs
- Assessing Potential Regulatory Drivers

Facility Capacity Assessment



- Flows & Loads - Drive core process needs
- Existing WWTP design (2014 expansion) – ADWF – 4 mgd

Item	Existing	Projected 2045
Average Dry Weather Flow, mgd	1.94	2.68 (~38% > existing)
Average Annual Flow, mgd	2.24	3.03 (~35% > existing)
Maximum Month Wet Weather Flow, mgd	3.78	4.90 (~30% > existing)
Average Annual BOD ⁵ , ppd	7,470	10,613 (~40% > existing)
Average Annual TSS, ppd	6,427	8,714 (~35% > existing)

Asset Condition Assessment



- Process Condition/Age Drivers
 - 2014 project facilities and equipment in service > 30 years by 2045
 - Solids facilities –
 - Performance issues
 - Solids Dryer fire (2019), component failures (2021), uneven performance
 - Solids Dewatering Centrifuges uneven performance (2020/21)
 - Secondary clarifiers – Pre-date 2014 upgrades, near term mechanism replacements, clarifiers no. 1 and 2
 - UV Disinfection – backup unit pre-dates 2014 upgrades, near term replacement

Potential Regulatory Drivers



- DEQ - Total Maximum Daily Load (TMDL)
Lower Willamette River
- Dissolved oxygen & nutrients
 - Nutrients can contribute to low oxygen conditions
 - Anticipate and accommodate future phosphorous, possibly nitrogen limits
- Pay attention to Willamette River
temperature concerns

Unit Process Capacity Summary

Unit Process	Design Parameter	Redundancy Criteria	Possible Year of Capacity Exceedance	Identified Alternatives
Secondary Treatment	MW MLSS inventory @ PDF	All units in service	2038	<ul style="list-style-type: none"> • New Aeration Basin • New Secondary Clarifier
Aeration Blowers	Peak BOD Load	Largest unit out of service	2035	<ul style="list-style-type: none"> • Additional Blower
Disk Filters	MWDWF	One unit in backwash	2037	<ul style="list-style-type: none"> • Third Disc Filter • Relax DBO limits
Biosolids Dryer	MW Load	All units in service	>2045	<ul style="list-style-type: none"> • Emergency Biosolids Management Plan • Redundant Dryer, similar technology • Different Dryer technology

Alternatives Evaluation



- Consider alternatives for process units identified as capacity deficient
- Secondary Process
 - Add new Aeration Basin
 - Add new blower
- Tertiary Disk Filters
 - Relax DBO effluent TSS limits
- Solids Dryer – driven by performance, not necessarily capacity
 - Further study, placeholder to expand dewatering and drying building, add new paddle dryer, refurbish existing dryer (backup)

Recommended Plan

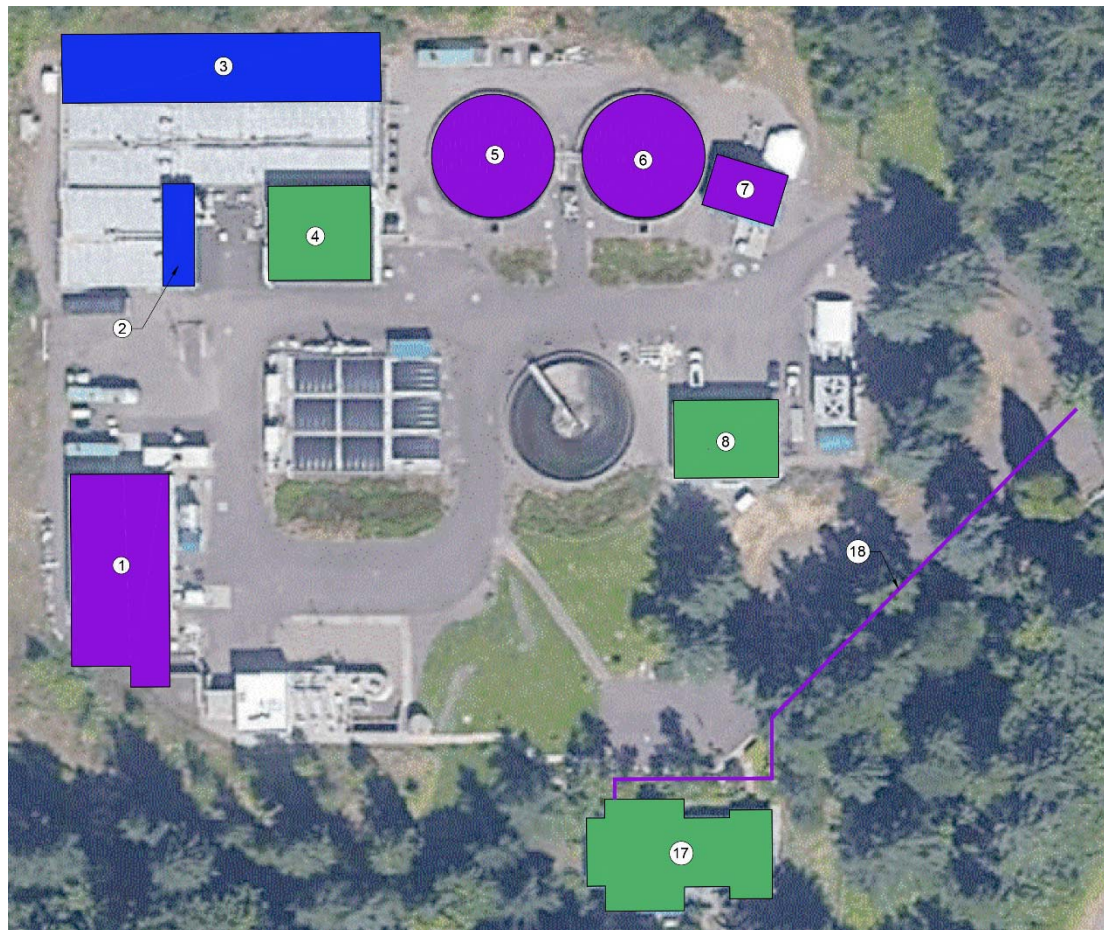

- ③ New Aeration Basin
- ② Additional Aeration Blower
- ⑦ Replace backup UV system
- ① Plan to replace Solids Dryer & Centrifuges
- ⑤ ⑥ Replace Clarifier 1 & 2 mechanisms
- ④ ⑧ Seismic retrofits of buildings
- ⑬ ⑭ New fiber optic connection

Solids process study

Proposed Project Phasing Schedule



Draft Cash Flow

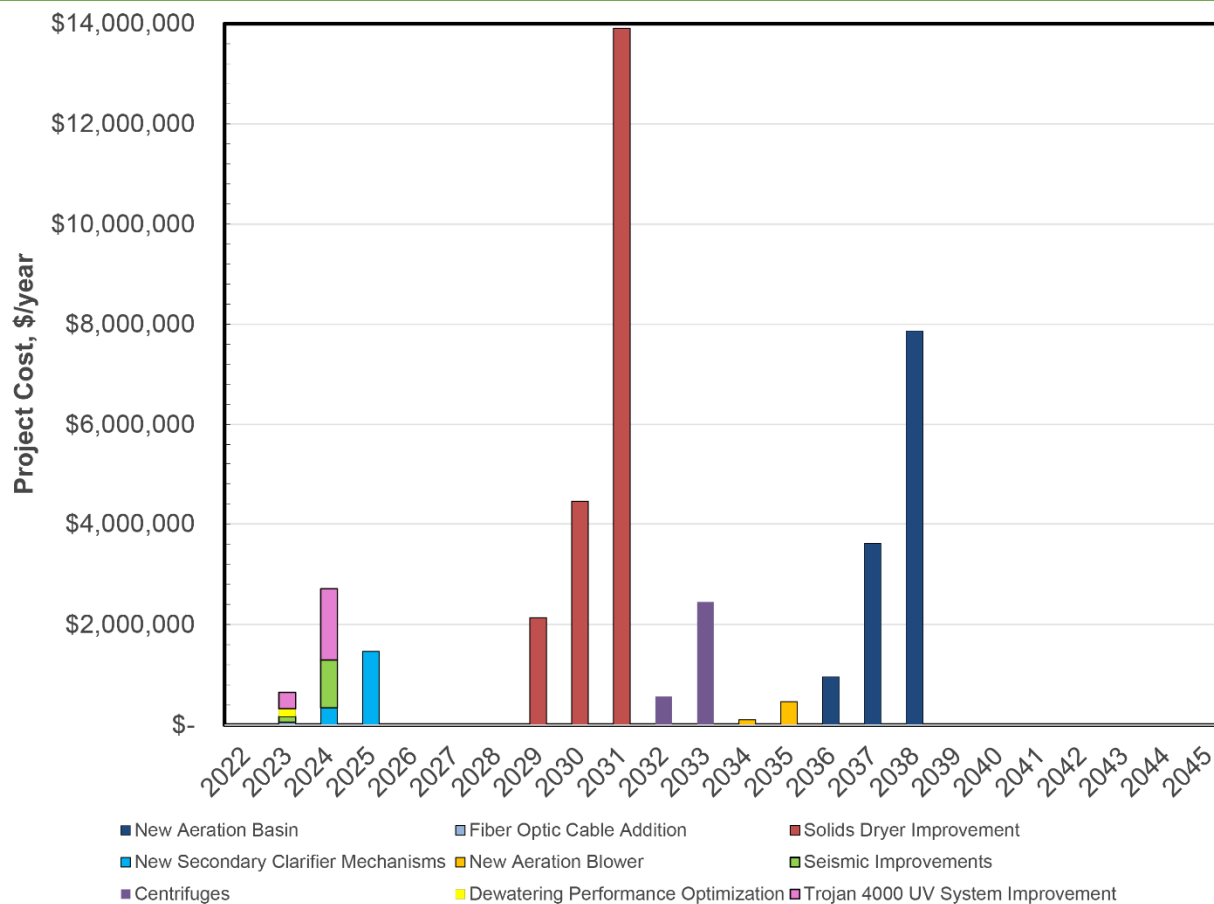

Next Steps



- DEQ review and approval of Plan
- Virtual Public Open House (8/24)
- Planning Commission Work Session 9/14
- Planning Commission Public Hearing 10/12
- City Council Public Hearing 1st Reading 11/7
- City Council 2nd Reading 11/21
- Sewer System Rate Study and SDC Update FY23

Questions?

Reference Slides

Capital Planning and Expected Growth - 2045

- Current Service Area needs
 - 20+ years through 2045
 - Population and associated economic development

2015	2020	2030	2045
22,870	25,915	29,756	30,566

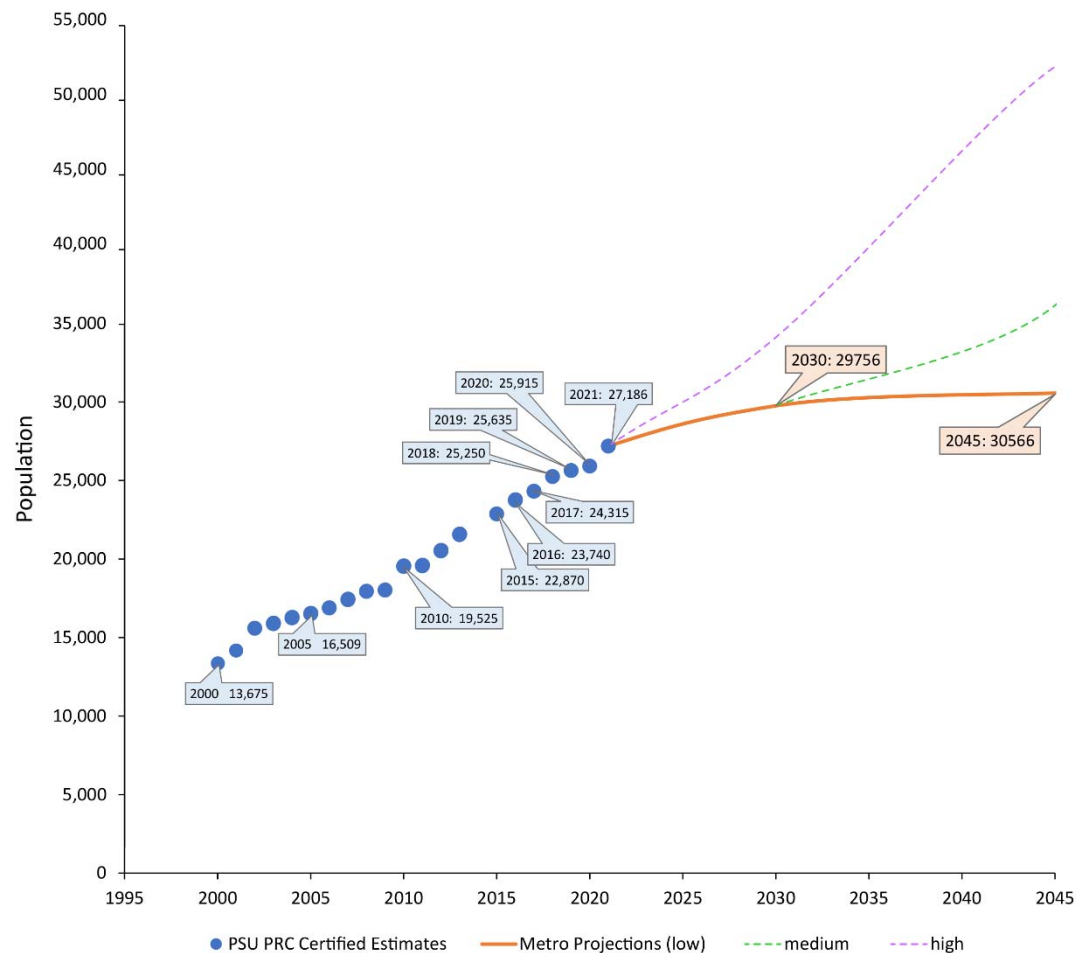

Condition Assessment



- Prioritize 2019 findings of consultant assessments
 - Secondary clarifiers
 - UV system
- Geotechnical and seismic evaluations
 - Older buildings found to present moderate risk
 - Identified mitigations to address seismic concerns
 - Operations Building
 - Process Gallery
 - Workshop

Alternatives Evaluation

- Solids Dryer – driven by performance, not capacity
 - Further study, placeholder to expand dewatering and drying building, add new paddle dryer, refurbish existing dryer (backup)
 - Largest potential investment in Master Plan

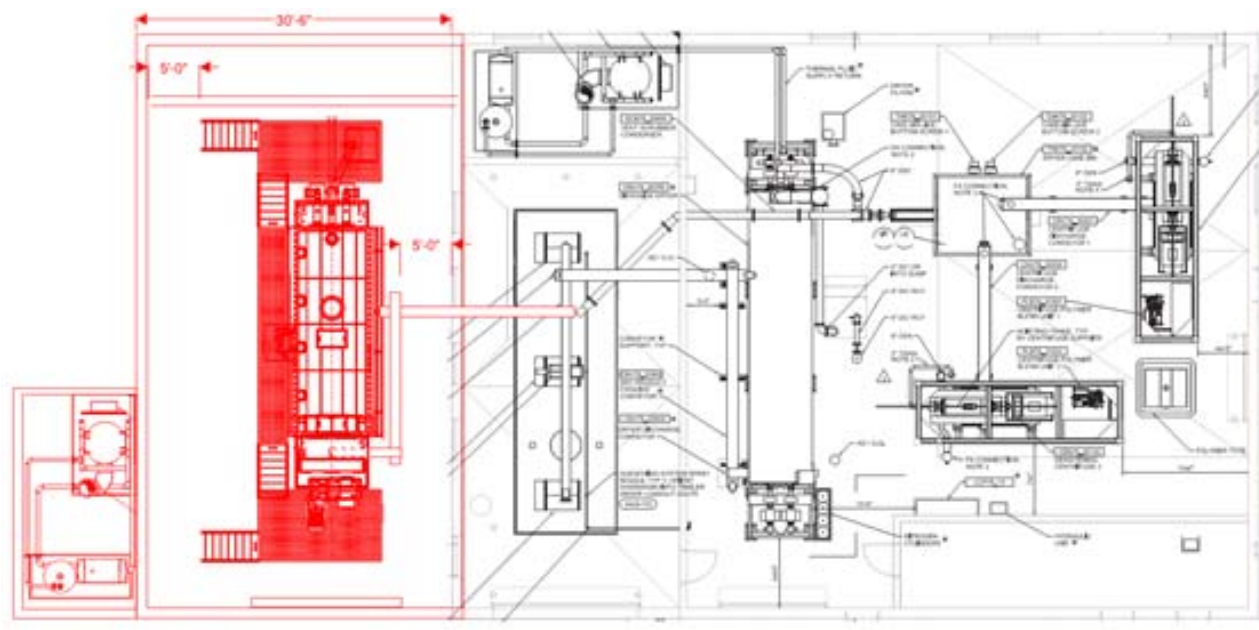

City Council Meeting Action Minutes August 1, 2022

City Council members present included:

Mayor Fitzgerald
Council President Akervall
Councilor Lehan
Councilor West
Councilor Linville

Jeanna Troha, Assistant City Manager
Delora Kerber, Public Works Director
Martin Montalvo, Public Works Ops. Manager
Mark Ottenad, Public/Government Affairs Director
Mike Nacrelli, Civil Engineer
Cindy Luxhoj, Associate Planner
Zach Weigel, City Engineer
Martin Montalvo, Public Works Ops. Manager
Zoe Mombert, Assistant to the City Manager
Ryan Adams, Assistant City Attorney

Staff present included:

Amanda Guile-Hinman, City Attorney
Kimberly Veliz, City Recorder

AGENDA ITEM	ACTIONS
WORK SESSION	START: 5:05 p.m.
A. Public Works Complex Construction Contract	Council was informed of Resolution No. 2988, which authorizes the City Manager to execute a construction contract with Emerick Construction Company for construction of the Public Works Complex Project.
B. Waste Water Treatment Plant Master Plan	Staff shared tenets of a draft Wastewater Treatment Master Plan that accommodates the City's projected 20-year growth, addresses seismic resiliency and identifies assets to be upgraded and/or replaced.
C. 2023 League of Oregon Cities Legislative Priorities Ballot	The City's lobbyist sought the Council's direction to finalize the legislative priorities to be listed on the League of Oregon Cities' (LOC) legislative priority ballot.
REGULAR MEETING	
<u>Mayor's Business</u>	
A. July 30, 2022 Curtailment Event	Staff explained the water pump failure at the Willamette River Water Treatment Plant (WRWTP) and the subsequent Water Curtailment Notice for the cities of Wilsonville and Sherwood.
B. Upcoming Meetings	Upcoming meetings were announced by the Mayor as well as the regional meetings she attended on behalf of the City.

<p><u>Communications</u></p> <p>A. Tourism Promotion Committee Marketing</p>	<p>City Council heard highlights about the City's current promotional activities displayed on ExploreWilsonville.com, which are designed to attract visitors for overnight lodging.</p>
<p><u>Consent Agenda</u></p> <p>A. <u>Resolution No. 2988</u> Authorizing the City Manager to execute a construction contract with Emerick Construction Company for construction of the Public Works Complex Project (Capital Improvement Project #8113).</p> <p>B. <u>Resolution No. 2991</u> A Resolution Of The City Of Wilsonville Authorizing The City Manager To Execute The Second Amendment To Construction Contract With Moore Excavation, Inc. For The 5th Street / Kinsman Road Extension Project.</p> <p>C. Minutes of the July 18, 2022 City Council Meeting.</p>	<p>The Consent Agenda was approved 5-0.</p>
<p><u>New Business</u></p> <p>A. None.</p>	
<p><u>Continuing Business</u></p> <p>A. None.</p>	
<p><u>Public Hearing</u></p> <p>A. <u>Ordinance No. 865</u> An Ordinance Of The City Of Wilsonville Approving A Zone Map Amendment From The Future Development Agricultural – Holding (FDA-H) Zone To The Planned Development Industrial (PDI) Zone On Approximately 0.55 Acre Located At 28505 SW Boones Ferry Road; The Land Is More Particularly Described As Tax Lot 800, Section 14A, Township 3 South, Range 1 West, Willamette Meridian, Clackamas County, Oregon. Davidsons Boones Ferry Industrial LLC, Owner/Applicant.</p>	<p>After a public hearing was conducted, Ordinance No. 865 was approved on first reading by a vote of 5-0.</p>
<p><u>City Manager's Business</u></p>	<p>No report.</p>
<p><u>Legal Business</u></p>	<p>No report.</p>

URBAN RENEWAL AGENCY	
<p><u>URA Consent Agenda</u></p> <p>A. <u>URA Resolution No. 327</u> A Resolution Of The City Of Wilsonville Urban Renewal Agency Authorizing The City Manager To Execute The Second Amendment To Construction Contract With Moore Excavation, Inc. For The 5th Street / Kinsman Road Extension Project.</p> <p>B. Minutes of the June 20, 2022 Urban Renewal Agency Meeting.</p>	The URA Consent Agenda was approved 5-0.
<p><u>New Business</u></p> <p>A. None.</p>	
<p><u>URA Public Hearing</u></p> <p>A. None.</p>	
EXECUTIVE SESSION	Pursuant to ORS 192.660(2)(h) Legal Counsel/Litigation
ADJOURN	9:01 p.m.



PLANNING COMMISSION

WEDNESDAY, JULY 13, 2022

WORK SESSION

2. Wastewater Treatment Plant Master Plan (Nacrelli) (45 minutes)



PLANNING COMMISSION WORK SESSION STAFF REPORT

Meeting Date: July 13, 2022		Subject: Wastewater Treatment Plant Master Plan	
		Staff Member: Mike Nacrelli, Senior Civil Engineer	
		Department: Community Development	
Action Required		Advisory Board/Commission Recommendation	
<input type="checkbox"/> Motion <input type="checkbox"/> Public Hearing Date: <input type="checkbox"/> Ordinance 1 st Reading Date: <input type="checkbox"/> Ordinance 2 nd Reading Date: <input type="checkbox"/> Resolution <input checked="" type="checkbox"/> Information or Direction <input type="checkbox"/> Information Only <input type="checkbox"/> Council Direction <input type="checkbox"/> Consent Agenda		<input type="checkbox"/> Approval <input type="checkbox"/> Denial <input type="checkbox"/> None Forwarded <input checked="" type="checkbox"/> Not Applicable Comments: N/A	
Staff Recommendation: Provide requested input regarding recommended capital improvement plan.			
Recommended Language for Motion: N/A			
Project / Issue Relates To:			
<input checked="" type="checkbox"/> Council Goals/Priorities: Align infrastructure plans with sustainable financing resources.	<input type="checkbox"/> Adopted Master Plan(s):	<input type="checkbox"/> Not Applicable	

ISSUE BEFORE PLANNING COMMISSION:

Provide feedback and input on components of the Wastewater Treatment Plant (WWTP) Master Plan.

EXECUTIVE SUMMARY:

This new City of Wilsonville (City) Wastewater Treatment Plant (WWTP) Master Plan (the Plan) has been developed to satisfy requirements associated with the State of Oregon Department of Environmental Quality (DEQ) guidance document entitled “Preparing Wastewater Planning Documents and Environmental Reports for Public Utilities.” To accommodate future flows and loads, projections were developed based on population projections and referencing WWTP historical data and DEQ wet weather project methodologies. Similarly, to accommodate future water quality regulations, the Plan is adaptive and considers potential future regulatory changes.

The City prepared the Plan with the goal of developing a capital plan that identifies improvements required through the planning period (today through 2045) to comply with requirements of the WWTP National Pollutant Discharge Elimination System (NPDES) permit and potential future regulatory requirements, while accommodating growth identified in the City of Wilsonville Comprehensive Plan (October 2018, updated June 2020 - the 2018 Comprehensive Plan). These improvements are designed to provide the best value to the City’s ratepayers by maximizing the use of existing infrastructure and improving system operation while continuing to protect water quality and human health and supporting economic development, consistent with goals and policies contained in the 2018 Comprehensive Plan and 2021-2023 City Council Goals.

The City’s WWTP was originally built in 1971 and discharges treated effluent to the Willamette River. The WWTP underwent major upgrades in 2014 to expand the average dry weather capacity to four million gallons per day (mgd) to accommodate the City’s continued growth. The WWTP processes include headworks screening and grit removal facilities, aeration basins, stabilization basins, secondary clarifiers, biosolids processing, cloth filtration, and disinfection processes. Additionally, the City contracts with Jacobs for operation of the wastewater treatment plant, located at 9275 Southwest Tauchman Road.

This Plan identifies improvements taking into consideration:

- The age and condition of existing process equipment and structures,
- Growth in demand for sewer service due to increased population and economic development over the planning period,
- Potential changes to water quality regulations impacting process needs in order to meet effluent limitations and discharge prohibitions imposed by the Oregon Department of Environmental Quality (DEQ), and
- Consistency with the 2018 Comprehensive Plan and City Council 2021-2023 Goals 5, 6 and 7.

WWTP Condition Assessment

Carollo reviewed prior condition assessments performed by others, conducted geotechnical investigations and performed seismic assessments at the WWTP in the course of Plan development.

In 2019, Jacobs Engineering Group Inc. (Jacobs) and Brown and Caldwell both completed condition assessments at the City’s WWTP. A total of 322 major assets (per Jacobs’ report), including process and mechanical equipment, motors and drives, control panels, generators,

instrumentation, and structures, were examined for a variety of conditions that may signify their need for maintenance or replacement.

Seismic Analysis

In 2021, Carollo performed a seismic evaluation and analysis of the City's WWTP as part of the overall plant condition assessment. Because the WWTP was substantially upgraded and expanded in 2014, most of its infrastructure is designed in accordance with the 2010 Oregon Structural Specialty Code (OSSC) and follows modern seismic design and detailing. During Tier 1 evaluations, Carollo identified potential deficiencies and areas for additional investigation. A Tier 1 seismic analysis is an initial evaluation performed to identify any potential deficiencies, whether structural or non-structural, in a building based on the performance of other similar buildings in past earthquakes. Subsequent to the Tier 1 analysis, a more detailed seismic evaluation of five older and potentially seismically vulnerable structures on the WWTP site was conducted. Those structures receiving a more detailed evaluation included the following:

- Operations Building
- Process Gallery
- Workshop
- Aeration Basins and Stabilization Basins
- Sludge Storage Basins and Biofilter

The five potentially vulnerable structures were compared against an S-4 Limited Safety structural performance level and N-B Position Retention non-structural performance level for an M9.0 Cascadia Seismic Zone (CSZ) earthquake. The M9.0 CSZ is reflective of a catastrophic natural disaster event that has an estimated 35 percent likelihood of occurring within the next 50 years. Following the Tier 1 evaluation, Carollo began Tier 2 evaluations for a select number of identified deficiencies. Although none of the structures showed significant irregularities, the team did identify seismic deficiencies. The recommended seismic retrofits are included in the CIP for the Plan.

Prior to the 2021 seismic evaluation, Carollo's subconsultant, Northwest Geotech, Inc. (NGI), completed a seismic response and geologic hazards assessment of the City's WWTP. Through past and present site investigations and engineering analyses, NGI determined that the native soils beneath the site's granular pit backfill have low risk of liquefaction and its slopes do not pose undue risk. NGI concluded that the WWTP's primary site hazard is the differential settlement that may be caused by soil piping (development of subsurface air-filled voids), which raises the risk of sinkholes forming beneath structures and pipelines. Soil piping usually develops in unsaturated soils when a water source percolates into the ground. While the site is mostly paved and stormwater is being collected, there may be areas where infiltration is occurring next to structures or below pipelines. Recommended actions from NGI to mitigate the risk of soil piping are presented in the Plan.

Wastewater Flow and Load Projections

The Plan evaluates the historical and projected wastewater flows and loads generated in the City of Wilsonville's service area. The load projections include total suspended solids (TSS), biochemical oxygen demand (BOD5), ammonia (NH3), and total phosphorous (TP) loads.

Service area, residential population, industrial contribution, and rainfall records were all considered in the flow and load projection analyses.

Capacity Analysis

Summaries of plant process area capacity assessments and conclusions are presented in the Plan. These assessments focus on the need for improvements or upgrades to existing facilities to address capacity deficiencies identified in the course of Master Plan evaluations.

Regulatory Considerations and Strategy

Several possible regulatory actions by the Oregon DEQ could drive investments in future improvements at the City's WWTP. The plant discharges to the Willamette River and existing and future effluent limitations contained in the NPDES permit dictate, in large part, the necessary treatment processes and configuration at the WWTP necessary to maintain compliance. The existing permit limits for the Wilsonville WWTP are effective September 1, 2020 through July 30, 2025.

Alternative Development and Evaluation

The Plan presents the methodology and findings of a process improvements alternatives evaluation. The plant's treatment process needs were defined by comparing the plant's existing condition, capacity and reliability, with the projected flows, loads, and regulatory constraints for the recommended alternatives. Where capacity deficiencies were predicted, at least two alternatives were analyzed for each corresponding unit process.

EXPECTED RESULTS:

The Plan includes a list of recommended capital improvements, along with an anticipated schedule for completion and preliminary cost estimates. These improvements will provide the basis for an analysis of sewer rates and system development charges (SDCs) that will be necessary to adequate funding to implement to required upgrades.

TIMELINE:

This is the first in a series of presentations to the Planning Commission and City Council. Subsequent planned meetings are as follows:

- City Council Work Session 8/1
- Planning Commission Public Hearing 9/14
- City Council Public Hearing 1st Reading 10/3
- City Council 2nd Reading 10/17

CURRENT YEAR BUDGET IMPACTS:

The remaining contract balance for finalizing the Plan will carry over into FY 22/23. An additional \$92,450 has been budgeted in FY 22/23 for the Sewer System Rate Study and SDC Update, using a combination of Sewer Operating funds and SDCs.

COMMUNITY INVOLVEMENT PROCESS:

The public hearings listed above will provide opportunity for public input. In addition, the Sewer System Rate Study and SDC Update will include a robust public engagement process.

POTENTIAL IMPACTS or BENEFIT TO THE COMMUNITY:

A technically and financially sound plan for providing reliable wastewater treatment, capacity to accommodate future development, and compliance with environmental regulations.

ALTERNATIVES:

The Plan includes alternatives for several of the recommended improvements. The selected alternatives were determined to be the most economically viable. Some of the more capital intensive alternatives can be revisited if necessary due to changing regulatory requirements.

ATTACHMENTS:

Attachment 1 Draft Wastewater Treatment Plant Executive Summary (dated June 2022)



City of Wilsonville
Wastewater Treatment Plant Master Plan

EXECUTIVE SUMMARY

DRAFT | June 2022





City of Wilsonville
Wastewater Treatment Plant Master Plan

EXECUTIVE SUMMARY

DRAFT | June 2022

Contents

Executive Summary

ES.1 Planning Area Characteristics	ES-6
ES.2 WWTP Condition Assessment	ES-10
ES.3 Seismic Analysis	ES-10
ES.4 Wastewater Flow and Load Projections	ES-11
ES.5 Capacity Analysis	ES-13
ES.6 Regulatory Considerations and Strategy	ES-19
ES.7 Alternative Development and Evaluation	ES-20
ES.8 Recommended Alternative	ES-24

Tables

Table ES.1	CIP Condition Driven Replacement Projects	ES-10
Table ES.2	Existing (2020) Flow Summary	ES-12
Table ES.3	2045 Flow Projections	ES-12
Table ES.4	Load Projections	ES-13
Table ES.5	Unit Process Capacity Assessment	ES-17
Table ES.6	Unit Process Capacity Year Summary	ES-19
Table ES.7	Current Effluent Permit Limits	ES-20
Table ES.8	Secondary Alternatives Opinion of Probable Cost Comparison	ES-21
Table ES.9	Summary of Alternatives	ES-23
Table ES.10	WWTP Recommended Alternative Opinion of Probable Cost and Phasing	ES-24

Figures

Figure ES.1	Planning Area	ES-7
Figure ES.2	Historical Population and Expected Growth for the City of Wilsonville	ES-9
Figure ES.3	Existing Wilsonville WWTP	ES-15
Figure ES.4	Proposed WWTP Improvements Site Plan	ES-25
Figure ES.5	Projected 20-Year CIP Expenditures	ES-27

-This Page Intentionally Left Blank-

Abbreviations

AA	average annual
AAF	average annual flow
ABF	Average base flow
ADWF	average dry-weather flow
AWWF	average wet weather flow
BCR	biochemical reactor
BOD ₅	biochemical oxygen demand
CIP	Capital Improvement Plan
City	the City of Wilsonville
CBOD ₅	five-day carbonaceous biochemical oxygen demand
CSZ	Cascadia Seismic Zone
DBO	Design-Build-Operate
DEQ	Department of Environmental Quality
DMR	Discharge Monitoring Reports
ETL	excess thermal load
gpd/sf	gallons per day per square foot
HMI	human-machine interface
Jacobs	Jacobs Engineering Group Inc.
kcal/day	kilocalories per day
lbs	pounds
MBR	membrane bioreactor
mg/L	milligrams per liter
mgd	million gallons per day
MGI	Northwest Geotech, Inc.
ml	milliliter
MLSS	mixed liquor suspended solids
MM	maximum month
MMDWF	maximum month dry weather flow
MMWWF	maximum month wet weather flow
MW	maximum week
MWDWF	maximum month dry weather flow
MWWWF	maximum week wet weather flow
NH ₃	ammonia
No.	number
NPDES	National Pollutant Discharge Elimination System
OSSC	Oregon Structural Specialty Code
PD	peak day

PDDWF	peak day dry weather flow
PDWWF	peak day wet weather flow
PHF	peak hour flow
ppd	pounds per day
PSU PRC	Portland State University Population Research Center
R/C	residential/commercial
SPA	State Point Analysis
SRT	solids residence time
the Plan	Master Plan
TMDL	total maximum daily loads
TP	total phosphorous
TS	total solids
TSS	total suspended solids
TWAS	thickened waste activated sludge
UGB	urban growth boundary
UV	ultraviolet
WWTP	wastewater treatment plant

EXECUTIVE SUMMARY

This new City of Wilsonville (City) Wastewater Treatment Plant (WWTP) Master Plan (the Plan) has been developed to satisfy requirements associated with the State of Oregon Department of Environmental Quality (DEQ) guidance document entitled “Preparing Wastewater Planning Documents and Environmental Reports for Public Utilities.” To accommodate future flows and loads, projections were developed based on population projections and referencing WWTP historical data and DEQ wet weather project methodologies. Similarly, to accommodate future water quality regulations, the Plan is adaptive and considers potential future regulatory changes.

The City prepared the Plan with the goal of developing a capital plan that identifies improvements required through the planning period (today through 2045) to comply with requirements of the WWTP National Pollutant Discharge Elimination System (NPDES) permit and potential future regulatory requirements, while accommodating growth identified in the City of Wilsonville Comprehensive Plan (October 2018, updated June 2020 - the 2018 Comprehensive Plan). These improvements are designed to provide the best value to the City’s ratepayers by maximizing the use of existing infrastructure and improving system operation while continuing to protect water quality and human health and supporting economic development, consistent with goals and policies contained in the 2018 Comprehensive Plan and 2021-2023 City Council Goals.

The City’s WWTP was originally built in 1971 and discharges treated effluent to the Willamette River. The WWTP underwent major upgrades in 2014 to expand the average dry weather capacity to four million gallons per day (mgd) to accommodate the City’s continued growth. The WWTP processes include headworks screening and grit removal facilities, aeration basins, stabilization basins, secondary clarifiers, biosolids processing, cloth filtration, and disinfection processes. Additionally, the City contracts with Jacobs for operation of the wastewater treatment plant, located at 9275 Southwest Tauchman Road.

This Plan identifies improvements taking into consideration:

- The age and condition of existing process equipment and structures,
- Growth in demand for sewer service due to increased population and economic development over the planning period,
- Potential changes to water quality regulations impacting process needs in order to meet effluent limitations and discharge prohibitions imposed by the Oregon Department of Environmental Quality (DEQ), and
- Consistency with the 2018 Comprehensive Plan and City Council 2021-2023 Goals 5, 6 and 7.

ES.1 Planning Area Characteristics

Chapter 1 summarizes the City’s wastewater service area characteristics relevant to assessing WWTP facility needs. The planning area considered by this Plan is consistent with the City’s 2014 Collection System Master Plan and 2018 Comprehensive Plan including the urban growth boundary (UGB), which is currently the limit of City sewer service as shown in Figure ES 1.

EXECUTIVE SUMMARY | WASTEWATER TREATMENT PLANT MASTER PLAN | CITY OF WILSONVILLE

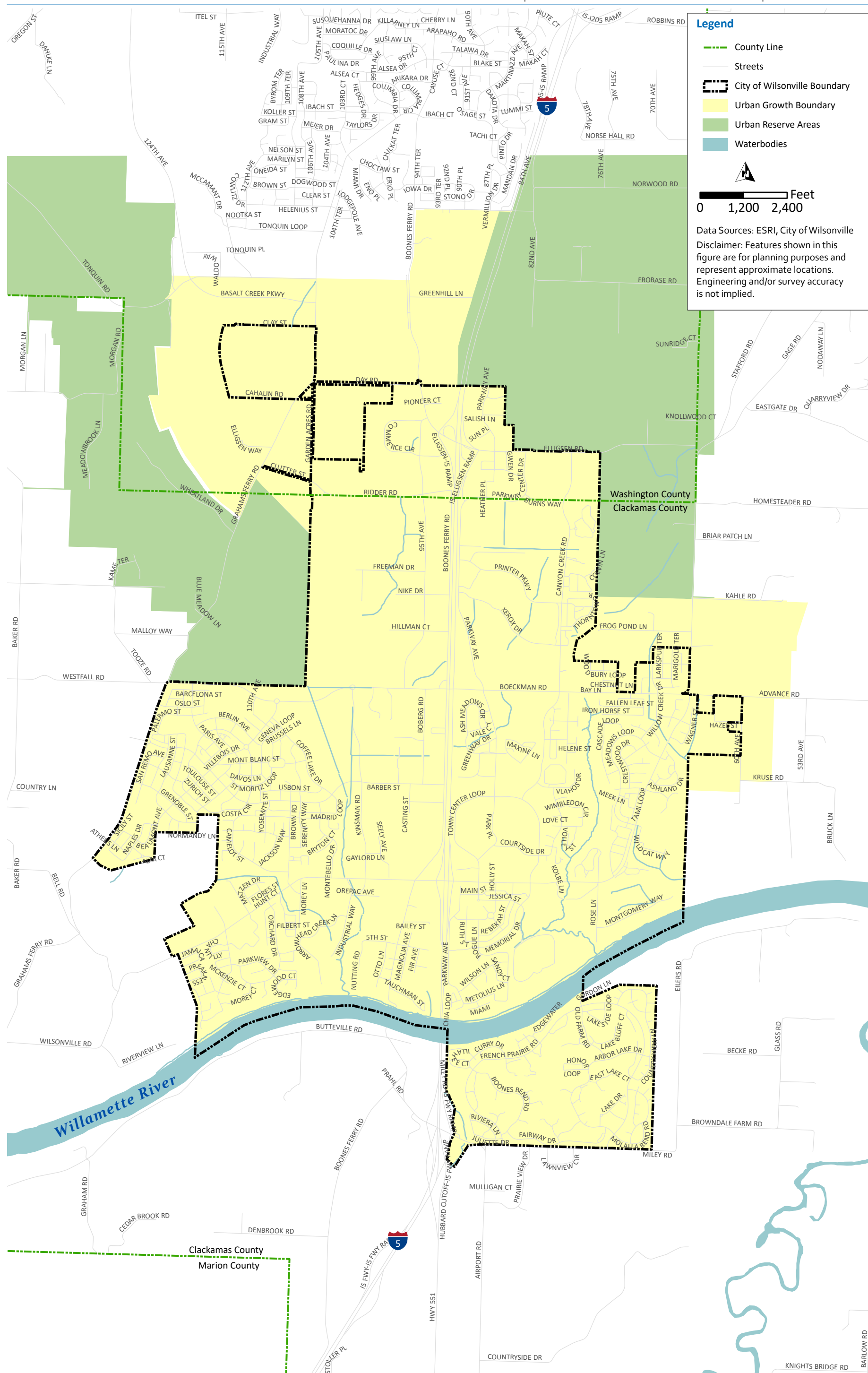

-This Page Intentionally Left Blank-

The northern portion of the City of Wilsonville is located within Washington County, and the majority of the City lies in the southwestern part of Clackamas County.

The City sits within the jurisdictional boundaries of Metro, the regional government for the Portland metropolitan area. By state law, Metro is responsible for establishing the Portland metropolitan area’s UGB, which includes Wilsonville. Land uses and densities inside the UGB require urban services such as police and fire protection, roads, schools, and water and sewer systems. A figure of the City’s existing land use is presented in Chapter 1. Also presented in Chapter 1 are the City’s physical characteristics, water resources, and population and employment information, which are all significant factors in planning for wastewater conveyance and treatment facilities.

The Portland State University Population Research Center (PSU PRC) publishes annual estimates of populations for the previous year for cities in Oregon while Metro develops population projections for the future within the Portland metropolitan area, including Wilsonville. The PSU PRC estimated the City’s population as 25,625 in 2019. Metro estimates the City’s population to reach 30,566 people by 2045.

For establishing a per capita basis for flow and load projections for the Plan, certified PSU PRC historical population estimates were used for 2015 through 2019. Metro’s future population forecasts were used for 2020 through 2045. Figure ES.2 shows the historical population and future growth predicted for the City.

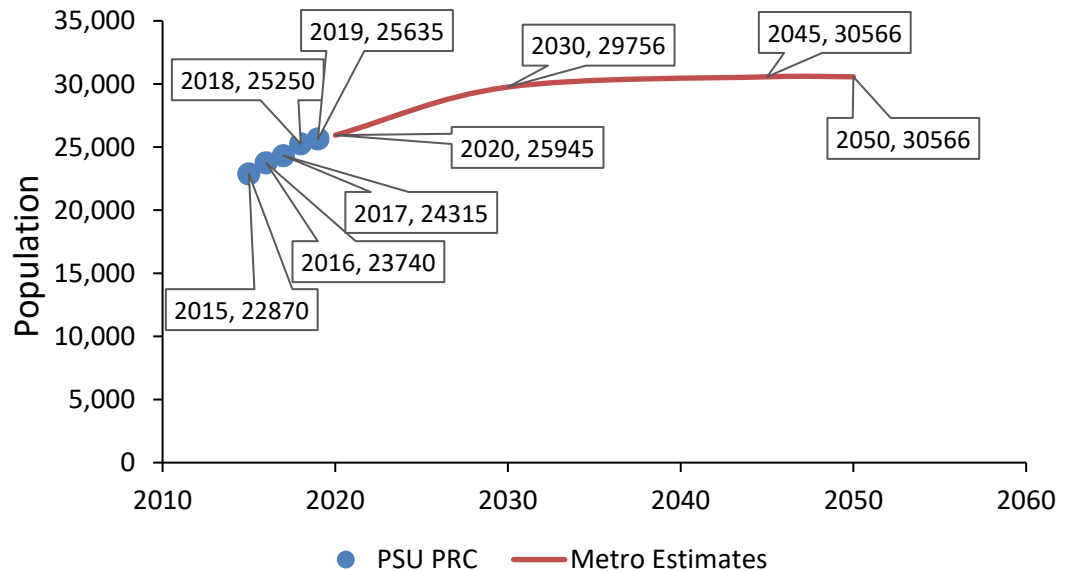

Figure ES.2 Historical Population and Expected Growth for the City of Wilsonville

ES.2 WWTP Condition Assessment

Carollo reviewed prior condition assessments performed by others, conducted geotechnical investigations and performed seismic assessments at the WWTP in the course of Plan development.

In 2019, Jacobs Engineering Group Inc. (Jacobs) and Brown and Caldwell both completed condition assessments at the City’s WWTP. A total of 322 major assets (per Jacobs’ report), including process and mechanical equipment, motors and drives, control panels, generators, instrumentation, and structures, were examined for a variety of conditions that may signify their need for maintenance or replacement. Chapter 2 presents a summary of critical assets that require short term rehabilitation or replacement, as well as a list of assets that are less critical to operations, or have minor condition issues, but may be included in a short-term improvements project or a task order for Jacobs operations personnel. Table ES.1 displays the condition driven rehabilitation or replacement projects from Chapter 2 that were included in the recommended Capital Improvement Plan (CIP) in Chapter 7.

Table ES.1 CIP Condition Driven Replacement Projects

Asset	Description
Trojan UV 4000 System	While only used as a backup to the Ozonia UV system, the Trojan system’s HMI has errors that prevent it from showing the status of the lamps in module 3. Since it is used infrequently, the system’s condition is largely unknown. After review of the 2019 condition assessment reports and discussion with the City and Jacobs staff, it was concluded that the UV 4000 unit must be replaced.
Secondary Clarifiers No. 1 and No. 2	Ovivo completed a field review of the plant’s secondary clarifiers No. 1 and No. 2 in April 2022. Although both units were operational, repairs were identified to improve the operation of the clarifiers. The recommended repairs include drive controls for both units, new skimmers for both units, squeegees for both tanks rake arms, EDI chains, one motor and reducer assembly, one skimmer arm assembly, and new secondary clarifier mechanisms. ⁽¹⁾

Notes:

(1) The detailed Ovivo Field Service Report is included in Appendix X.
Abbreviations: HMI - human-machine interface; No. - number; UV - ultraviolet.

ES.3 Seismic Analysis

In 2021, Carollo performed a seismic evaluation and analysis of the City’s WWTP as part of the overall plant condition assessment. Because the WWTP was substantially upgraded and expanded in 2014, most of its infrastructure is designed in accordance with the 2010 Oregon Structural Specialty Code (OSSC) and follows modern seismic design and detailing. During Tier 1 evaluations, Carollo identified potential deficiencies and areas for additional investigation. A Tier 1 seismic analysis is an initial evaluation performed to identify any potential deficiencies, whether structural or non-structural, in a building based on the performance of other similar buildings in past earthquakes. Subsequent to the Tier 1 analysis, a more detailed seismic

evaluation of five older and potentially seismically vulnerable structures on the WWTP site was conducted. Those structures receiving a more detailed evaluation included the following:

- Operations Building.
- Process Gallery.
- Workshop.
- Aeration Basins and Stabilization Basins.
- Sludge Storage Basins and Biofilter.

The five potentially vulnerable structures were compared against an S-4 Limited Safety structural performance level and N-B Position Retention non-structural performance level for an M9.0 Cascadia Seismic Zone (CSZ) earthquake. The M9.0 CSZ is reflective of a catastrophic natural disaster event that has an estimated 35 percent likelihood of occurring within the next 50 years. Following the Tier 1 evaluation, Carollo began Tier 2 evaluations for a select number of identified deficiencies. Although none of the structures showed significant irregularities, the team did identify seismic deficiencies. The recommended seismic retrofits are included in the CIP for this Plan.

Prior to the 2021 seismic evaluation, Carollo's subconsultant, Northwest Geotech, Inc. (NGI), completed a seismic response and geologic hazards assessment of the City's WWTP. Through past and present site investigations and engineering analyses, NGI determined that the native soils beneath the site's granular pit backfill have low risk of liquefaction and its slopes do not pose undue risk. NGI concluded that the WWTP's primary site hazard is the differential settlement that may be caused by soil piping (development of subsurface air-filled voids), which raises the risk of sinkholes forming beneath structures and pipelines. Soil piping usually develops in unsaturated soils when a water source percolates into the ground. While the site is mostly paved and stormwater is being collected, there may be areas where infiltration is occurring next to structures or below pipelines. Recommended actions from NGI to mitigate the risk of soil piping are presented in Chapter 2.

ES.4 Wastewater Flow and Load Projections

Chapter 3 of the Plan evaluates the historical and projected wastewater flows and loads generated in the City of Wilsonville's service area. The load projections include total suspended solids (TSS), biochemical oxygen demand (BOD₅), ammonia (NH₃), and total phosphorous (TP) loads.

Service area, residential population, industrial contribution, and rainfall records were all considered in the flow and load projection analyses.

Analysis of flow projections were completed through two different methods: (1) analysis of historical plant records and (2) DEQ Guidelines for Making Wet-Weather and Peak Flow Projections for Sewage Treatment in Western Oregon, which is referred to as the DEQ methodology in this Plan. Since there is no DEQ methodology for load analysis, all projections were developed based on historical plant records. Tables ES.2 and ES.3 below detail the existing and year 2045 flows that serve as the basis for the flow projections.

Table ES.2 Existing (2020) Flow Summary

Item	Selected Flow (mgd)	Industrial Flow (mgd)	R/C Flow (mgd)	R/C Peaking Factor
ABF	1.88	0.17	1.71	1.00
AAF	2.24	0.17	2.07	1.21
ADWF	1.94	0.17	1.77	1.03
AWWF	2.54	0.17	2.37	1.38
MMDWF	2.52	0.19	2.33	1.36
MMWWF	3.78	0.19	3.59	2.09
MWDWF	2.94	0.19	2.75	1.61
MWWWF	4.54	0.19	4.35	2.54
PDDWF	3.63	0.19	3.44	2.01
PDWWF	5.59	0.19	5.41	3.16
PHF	8.80	0.19	8.61	5.02

Notes:

Abbreviations: AAF - average annual flow; ABF - average base flow; ADWF - average dry-weather flow; AWWF - average wet weather flow; MMDWF - maximum month dry weather flow; MMDWF - maximum month dry weather flow MMWWF - maximum month wet weather flow; MWWWF - maximum week wet weather flow; PDDWF - peak day dry weather flow; PDWWF - peak day wet weather flow; PHF - peak hour flow; R/C - residential/commercial.

Table ES.3 2045 Flow Projections

Item	Existing R/C Flow (mgd)	R/C Peaking Factor	2045 R/C Flow	2045 Industrial Flow (mgd)	Projected 2045 WWTP Flow (mgd)
ABF	1.71	1.00	2.02	0.6	2.62
AAF	2.07	1.21	2.43	0.6	3.03
ADWF	1.77	1.03	2.08	0.6	2.68
AWWF	2.37	1.38	2.79	0.6	3.39
MMDWF	2.33	1.36	2.75	0.7	3.42
MMWWF	3.59	2.09	4.23	0.7	4.90
MWDWF	2.75	1.61	3.24	0.7	3.92
MWWWF	4.35	2.54	5.12	0.7	5.80
PDDWF	3.44	2.01	4.05	0.7	4.72
PDWWF	5.41	3.16	6.38	0.7	7.05
PHF	8.61	5.02	10.15	0.7	10.82

Load projections were calculated for influent TSS, BOD₅, NH₃, and TP as detailed below in Table ES.4.

Table ES.4 Load Projections

Load Parameters	2045 R/C (ppd)	2045 Industrial (ppd)	2045 WWTP (ppd)
BOD₅			
AA BOD ₅	8,000	2,613	10,613
MM BOD ₅	11,437	2,978	14,415
MW BOD ₅	14,307	2,978	17,285
PD BOD ₅	21,656	2,978	24,634
TSS			
AA TSS	7,097	1,617	8,714
MM TSS	9,535	1,844	11,379
MW TSS	12,478	1,844	14,322
PD TSS	16,295	1,844	18,139
NH₃			
AA NH ₃	695	171	866
MM NH ₃	800	171	971
MW NH ₃	1,035	171	1,205
PD NH ₃	1,443	171	1,614
Total Phosphorus (TP)			
AA TP	222	73	295
MM TP	318	83	400
MW TP	397	83	480
PD TP	601	83	684

Notes:

Abbreviations: AA - average annual; MM - maximum month; MW - maximum week; PD - peak day; ppd - pounds per day.

ES.5 Capacity Analysis

Summaries of plant process area capacity assessments and conclusions are presented in this Plan. These assessments focus on the need for improvements or upgrades to existing facilities to address capacity deficiencies identified in the course of Master Plan evaluations. A site plan of the City's existing WWTP is presented in Figure ES.3.

Chapter 4 identifies existing capacity ratings and deficiencies for the liquid and solids stream treatment processes at the City's WWTP. Analyses are based on operational practices in place at the time and existing effluent limits established by the WWTP's National Pollutant Discharge Elimination System (NPDES) permit. Biological process modeling was performed using BioWin version 6.2 to predict plant performance under current and future flow and loading conditions to assess when unit process capacities may be exceeded within the planning period (present through 2045).

A summary of the capacity assessment completed and presented in Chapter 4 is detailed below in Table ES.5.

-This Page Intentionally Left Blank-





- LEGEND:**
- 1 - DEWATERING & DRYING BUILDING
 - 4 - PROCESS GALLERY
 - 5 - SECONDARY CLARIFIER NO. 1
 - 6 - SECONDARY CLARIFIER NO. 2
 - 7 - UV DISINFECTION SYSTEM
 - 8 - WORKSHOP
 - 9 - SECONDARY PROCESS FACILITY
 - 10 - STABILIZATION BASIN
 - 11 - SLUDGE STORAGE BASINS AND BIOFILTERS
 - 12 - SECONDARY CLARIFIER NO. 3
 - 13 - HEADWORKS
 - 14 - DISK FILTERS
 - 15 - COOLING TOWERS
 - 16 - W3 REUSE PUMP STATION
 - 17 - OPERATIONS BUILDING
 - 19 - SITE ENTRANCE

Plot Date: 6/28/2022 9:15:35 AM

FILE NAME: 11962A00_FIGURE_SEED.DWG

LAST SAVED BY: bhawes

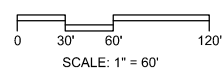

Figure ES.3
EXISTING WILSONVILLE WWTP
CITY OF WILSONVILLE



-This Page Intentionally Left Blank-

Table ES.5 Unit Process Capacity Assessment

Unit Process	Capacity Assessment
Preliminary Treatment	
Screening	There is sufficient hydraulic capacity for both mechanical screens to accommodate the projected 2045 PHF. However, if one screen is out of service, the manual bar rack must be used to make up the loss in screening capacity.
Grit Removal	Capacity is adequate for providing full treatment of the projected 2045 PHF.
Secondary Treatment	
Secondary Treatment	Based on maximum week MLSS predicted from BioWin modeling at peak day flow with all clarifiers in service (and assuming a 5-day SRT), a SPA predicts that there is only sufficient capacity through 2038. SPA also indicates that there is sufficient capacity using the predicted average annual MLSS concentrations and the peak day dry weather flows with a clarifier out of service for the duration of the planning period.
Secondary Clarifiers	The secondary clarifiers are expected to stay under the maximum hydraulic loading criteria of 920 gpd/sf on peak day flow events with all units in service, as well as on max month dry weather flows with one unit out of service, for the entirety of the planning period.
Aeration Blowers	The air demands of the secondary treatment process are projected to exceed the firm capacity of the aeration blowers under peak conditions by 2035.
Tertiary Treatment and Disinfection	
Disk Filters	The existing disk filter capacity is expected to be exceeded by 2037 with one unit out of service or in backwash mode based on effluent limitations included in the City's DBO Contract with Jacobs. At this time the City expects to relax these contract limitations rather than invest in additional capacity. There is sufficient time for the City to reconsider this approach prior to 2037 and evaluate options for adding capacity to the filtration process.
Secondary Effluent Cooling Towers	It is not expected that the total hydraulic capacity of the cooling towers will be exceeded by 2045.
UV Disinfection	The existing UV channels are adequately sized to fully disinfect the 2045 PHF with all units in service, as well as the PDDWF with one channel out of service. The City currently has an older UV unit in place as an emergency backup to the primary system. That backup unit is aging and the City plans replacement during the planning period.
Outfall	Even with the Willamette River at its 100-year flood elevation, it is expected that the outfall pipeline can accommodate approximately 19 mgd before the UV channel effluent weirs are at risk of submergence upstream. Since this flow is well above the hydraulic capacity of the rest of the plant, no expansion will be needed until after 2045. ⁽¹⁾
Solids Handling	
Gravity Belt Thickener	The capacity analysis results show that the assumed operating times of 24 hours per day, 5 days per week are adequate for thickening the current and projected maximum week WAS loads with one unit out of service.
TWAS Storage	The TWAS storage volume is sufficient to accommodate the expected maximum week solids loads for three days (assuming TWAS is thickened to 4 percent). However, if one of the two storage tanks is taken out of service, there is insufficient storage volume for three days of storage under average annual solids loading conditions.
Dewatering Centrifuges	The rated capacity of the current centrifuges is sufficient to process the maximum week load with one unit out of service through 2045 assuming operating times of 24 hours per day for 5 days per week, per the criteria detailed in Chapter 4. ⁽²⁾
Biosolids Dryer and Solids Disposal	The capacity of the biosolids dryer is adequate for handling the current and projected max week solids loads (in year 2045) on the basis of its design evaporation rate, assuming dewatered cake is dried from 20 percent TS to 92 percent TS and the dryer is operated for 24 hour per day for 5 days per week. ⁽³⁾

Notes:

- (1) The existing outfall was recently modified and equipped with five parallel diffuser pipes equipped with duckbill check valves to improve the mixing zone characteristics in the Willamette River.
- (2) The centrifuges installed with the City's 2014 upgrade project have exhibited inconsistent performance in recent months. The City recently refurbished these units and expects they will provide sufficient capacity through 2045. However, by that time, the units will have been in service for over 30 years. It is recommended the City plan for replacement of these units during the planning horizon of this Master Plan. Assuming replacement occurs in the mid-2030's the City should reassess capacity needs of those units beyond the 2045 horizon, consistent with the expected service life of the new equipment.
- (3) The existing solids dryer has sufficient capacity through 2045. As with the dewatering centrifuges, the dryer equipment will soon have been in operation for a decade. It is recommended the City plan for replacement of the dryer during the planning horizon of this Master Plan. The City plans to replace the existing dryer with a new piece of equipment using similar technology and potentially rehabilitate the existing unit to serve as a backup. See Alternative 2B, Chapter 6.

Abbreviations: DBO - Design-Build-Operate; gpd/sf - gallons per day per square foot; MLSS - mixed liquor suspended solids, SPA - State Point Analysis; SRT - solids residence time; TS - total solids; TWAS - thickened waste activated sludge.

-This Page Intentionally Left Blank-

Table ES.6 further summarizes the capacity assessment by listing each unit process, associated design parameters and year of possible capacity exceedance.

Table ES.6 Unit Process Capacity Year Summary

Unit Process	Design Parameter	Redundancy Criteria ⁽³⁾	Year of Capacity Exceedance
Influent Screening	PHF	One mechanical screen out of service	>2045
Grit Chamber	PHF	All units in service	>2045
Secondary Treatment	MW MLSS inventory at PDF	All units in service	2038
Aeration Blowers	Peak BOD Load	Largest unit out of service	2035
Secondary Effluent Cooling Towers	June 1 - Sept 30 PDF	All units in service	>2045
Disk Filters	MWDWF	One unit in backwash	2037⁽¹⁾
UV Disinfection Channels	PHF	All units in service	>2045
Outfall	PHF	-	>2045
Gravity Belt Thickening	MW Load	One unit out of service	>2045
TWAS Storage	MW Load	All units in service	>2045
Dewatering Centrifuges	MW Load	One unit out of service	>2045 ⁽²⁾
Biosolids Dryer	MW Load	All units in service	>2045 ⁽²⁾

Notes:

Unit processes in white are projected to run out of capacity before year 2045.

- (1) Existing Disk Filters are predicted to exceed reliable capacity (one unit out of service) in 2037 based on vendor provided design criteria. This conclusion assumes limitations for effluent total suspended solids contained in the WWTP DBO contract, which are far more stringent than the City's NPDES permit.
- (2) As noted previously, the existing centrifuges and biosolids dryer appear to have sufficient capacity through the planning year 2045, however condition and age are likely to require replacement during the planning period. It is recommended the City reassess available replacement technologies prior to replacement and consider loading appropriate to the planning horizon of any new units selected.
- (3) Reference Appendix D - Reliability requirements, Preparing Wastewater Planning Documents and Environmental Reports for Public Utilities, OR DEQ, 2018, Revised July 2019

ES.6 Regulatory Considerations and Strategy

Chapter 5 details potential regulatory issues the City will need to take into consideration in coming years. Several possible regulatory actions by the Oregon DEQ could drive investments in future improvements at the City's WWTP. The plant discharges to the Willamette River and existing and future effluent limitations contained in the NPDES permit dictate, in large part, the necessary treatment processes and configuration at the WWTP necessary to maintain compliance. The existing permit limits for the Wilsonville WWTP are effective September 1, 2020 through July 30, 2025, and summarized below in Table ES.7

Table ES.7 Current Effluent Permit Limits

Parameter	Average Effluent Concentrations		Monthly Average, (ppd)	Weekly Average, (ppd)	Daily Maximum, (lbs)
	Monthly	Weekly			
May 1 - October 31					
CBOD ₅	10 mg/L	15 mg/L	190	280	380
TSS	10 mg/L	15 mg/L	190	280	380
November 1 - April 30					
BOD ₅	30 mg/L	45 mg/L	560	840	1100
TSS	30 mg/L	45 mg/L	560	840	1100
Other Parameters Limitations					
E. coli Bacteria	<ul style="list-style-type: none"> • Shall not exceed 126 organisms per 100 ml monthly geometric mean. • No single sample shall exceed 406 organisms per 100 ml. 				
pH	<ul style="list-style-type: none"> • Instantaneous limit between a daily minimum of 6.0 and a daily maximum of 9.0 				
BOD ₅ Removal Efficiency	<ul style="list-style-type: none"> • Shall not be less than 85% monthly average 				
TSS Removal Efficiency	<ul style="list-style-type: none"> • Shall not be less than 85% monthly average 				
ETL June 1 through September 30	<ul style="list-style-type: none"> • Option A: 39 million kcal/day 7-day rolling average • Option B: Calculate the daily ETL limit 				

Notes:

Abbreviations: CBOD₅ - five-day carbonaceous biochemical oxygen demand; ETL - excess thermal load; kcal/day - kilocalories per day; lbs - pounds, mg/L - milligrams per liter; ml - milliliter.

Future treatment upgrades may be required when DEQ establishes total maximum daily loads (TMDL) for the lower Willamette River. Dissolved oxygen and nutrient limits, such as phosphorus limitations, are possible. The dissolved oxygen in the lower part of the river does not always meet water quality standards, and indications of excessive nutrients, such as chlorophyll-a, aquatic weeds, and harmful algal blooms, are present in the lower Willamette River. DEQ has begun its triennial review of Oregon’s water quality criteria. The review could result in more stringent or new discharge requirements, but this process will take several years. For planning purposes, providing plant footprint to accommodate future treatment to remove phosphorus and address dry weather seasonal limits on dissolved oxygen should be anticipated. In addition, the City should continue to engage with DEQ regarding any proposed receiving water temperature regulatory actions.

ES.7 Alternative Development and Evaluation

Chapter 6 presents the methodology and findings of a process improvements alternatives evaluation. The plant’s treatment process needs were defined by comparing the plant’s existing condition, capacity and reliability, with the projected flows, loads, and regulatory constraints for the recommended alternatives. Where capacity deficiencies were predicted, at least two alternatives were analyzed for each corresponding unit process. Process modifications associated with each alternative were modeled in BioWin using a calibrated model to evaluate the overall impact on plant operations.

As identified in Chapter 4, the secondary treatment process is expected to require additional capacity during the planning horizon (2045). Chapter 6 details two alternatives to address these capacity limitations. The two alternatives considered to increase secondary capacity are:

1. Expansion of the existing conventional activated sludge process; and
2. Intensification of the existing treatment process using membrane bioreactor (MBR) technology.

Due to the higher capital and operating costs of intensification, construction of a new conventional aeration basin is recommended to increase secondary capacity. As flows and loads increase, or regulatory requirements become more stringent, it may be necessary to intensify treatment. It is recommended the City revisit this evaluation as the need for 1) additional capacity to accommodate growth nears or 2) more stringent effluent limitations are considered. This offers the opportunity to take advantage of potential advances in technology as well as confirming the predicted time frame of capacity exceedance. Table ES.8 below illustrates the differences in cost between the two alternatives. A new aeration basin project is included in the Capital Improvement Plan in Chapter 7.

Table ES.8 Secondary Alternatives Opinion of Probable Cost Comparison

Description	New Aeration Basin	MBR
Site Work	\$1,273,000	\$62,000
Fine Screens	--	\$1,268,000
Aeration Basin	\$1,739,000	
MBR Tank	--	\$3,564,000
Electrical, Instrumentation, and Control	\$522,000	\$1,469,000
Total Direct Cost	\$3,534,000	\$6,363,000
Total Estimated Construction Cost⁽¹⁾	\$5,812,000	\$10,465,000
Total Estimated Project Cost⁽²⁾	\$7,265,000	\$13,081,000

Notes:

(1) Assumes 30% Contingency, 10% General Conditions, and 15% Contractor Overhead and Profit.

(2) Assumes 25% Engineering, Legal, and Administrative Fees and ENR Construction Cost Index = 12683 (February 2022).

The existing aeration blower system firm capacity is expected to be deficient by 2035. An additional aeration blower (same size and design air flow rate as the existing high-speed turbo blowers) would ensure there is sufficient blower capacity through the end of the planning period to meet current permit requirements. There is adequate space to add a fourth turbo blower to the same discharge header pipe as the existing turbo blowers. Additionally, intensification of the secondary treatment process would further increase the aeration demands because operating at a higher MLSS reduces oxygen transfer efficiency in the aeration basins. If intensification is reconsidered and selected for the planning period, or if nutrient limits are imposed within the planning period that requires intensification or operation at a higher MLSS, the blower air demands should be revisited.

Additional tertiary filtration capacity is predicted to be needed before 2045 to provide full treatment of the MWDWF with one disc filter out of service or in backwash mode. After discussions with the City, two alternatives were identified to increase capacity:

1. Increase filtration capacity, and
2. Modify the requirement in the WWTP DBO contract to relax effluent limitations which are currently more stringent than those contained in the City's NPDES permit.

The City's WWTP NPDES permit currently requires effluent to contain less than 10 mg/L TSS during the dry season (see Table ES.8). However, the DBO firm's contract with the City requires an effluent TSS of less than five mg/L, or half of the WWTP's permitted effluent quality. At this time, the City has decided to study the performance of the existing tertiary filters over time and expects to relax effluent TSS requirements in the DBO contract unless actual water quality impacts (exceedances of permit limitations) are realized. The City will also consider the option of new technologies for filtration, noting that if the City selected an intensification technology utilizing membranes, this may potentially eliminate tertiary filtration capacity concerns.

While the capacity assessment findings presented in Chapter 4 determined existing solids dewatering centrifuges have sufficient capacity, the remaining equipment service life may require replacement within the planning horizon. The centrifuges, installed in 2014, were recently refurbished, but by 2045, will have been in service for over 30 years. The City should plan for their replacement within the planning horizon and consider whether a capacity increase is needed at the time of replacement based on projections of solids production and processing needs. Additionally, the secondary process was modified in 2020 and has experienced extended periods where mixed liquor concentrations have been elevated above typical ranges for conventional activated sludge or extended aeration processes. Due to the complications with secondary process operation and performance issues with the centrifuges, it is recommended the City study the secondary treatment and dewatering processes to confirm that the assumptions and conclusions regarding centrifuge capacity in Chapter 4 may be relied upon. A dewatering performance optimization study is recommended so the City can collect and analyze secondary treatment and solids processing performance data. For budgeting purposes, an opinion of probable cost for replacing the existing centrifuges is provided in Chapter 7. Timing of that equipment replacement will depend on performance of the existing units, future loading assumptions, and observed condition.

The existing solids dryer has experienced operational issues in recent years, including a fire that caused extensive damage to the equipment in April 2019 and a leaking rotary joint and damaged seal in 2021. As of February 25, 2022, the dryer has been repaired and is operating. Because of the City's commitment to solids drying as the preferred process to achieve Class A biosolids, the alternatives evaluation presented in this Plan for future dryer replacement was conducted with a focus on thermal drying options only.

Chapter 6 details an analysis of the following alternatives to improve the drying system:

1. Alternative 1 - Continue operating the existing biochemical reactor (BCR) paddle dryer and defer replacement.
2. Alternative 2 - Modify the existing Dewatering and Drying Building to accommodate a different solids dryer technology or a redundant dryer.
3. Alternative 3 - Construct a new dryer building with a different solids dryer technology.

While it is anticipated the existing dryer has useful life through at least 2026 (current DBO contract expiration), by 2031 the dryer will have been in operation for over 15 years. It is recommended the planning and design of upgrades to provide reliable dryer capacity begin in 2029, or sooner if further operational concerns arise. The City has indicated a preference for a variation of Alternative 2 which involves expanding the existing Dewatering and Drying Building to accommodate a second solids paddle dryer. This alternative provides backup capacity to allow the City to continue delivering Class A solids during periods of downtime if a mechanical failure occurs or to accommodate regular maintenance of one dryer train. As mentioned previously, this Plan recommends the City complete a study of the secondary sludge quality, performance of that process, chemical addition types and locations, and solids handling process performance overall prior to making a final selection of the preferred dryer alternative from the alternatives detailed in Chapter 6. For purposes of capital planning, this Plan assumes the City will implement Alternative 2b (modification of Dewatering and Drying Building to accommodate a second paddle dryer) with a study and confirmation of this selection beginning in 2029.

Lastly, the City wants to establish a direct connection between the City’s fiber optics network and the WWTP. This addition consists of routing two new conduits (one spare) and fiber optic cabling from the WWTP’s Operations Building to the site entrance, where the conduits will be tied into the City’s fiber optics network. Chapter 6 details one potential routing from the Operations Building to the site entrance that would minimize impact to existing yard utilities. The fiber optic cable addition is included in Chapter 7 and the City’s 5-year CIP.

Table ES.9 below summarizes the alternatives evaluated in Chapter 6 including recommendations for future WWTP improvements.

Table ES.9 Summary of Alternatives

Unit Process	Alternatives Considered	Selected Alternative
Secondary Treatment	<ul style="list-style-type: none"> Expansion of the existing conventional activated sludge process. Intensification of the existing treatment process. 	<ul style="list-style-type: none"> Expansion of the existing conventional activated sludge process through the addition of another aeration basin.
Tertiary Treatment	<ul style="list-style-type: none"> Increase filtration capacity. Eliminate the requirement on the DBO firm to meet effluent limits more stringent than the NPDES permit. 	<ul style="list-style-type: none"> Eliminate the requirement on the DBO firm to meet effluent limits more stringent than the NPDES permit.
Solids Dryer	<ul style="list-style-type: none"> Continue operating the existing BCR paddle dryer and defer replacements. Modify the existing Dewatering and Drying Building to accommodate a different solids dryer technology or a redundant dryer. Construct a new dryer building with a different solids dryer technology. 	<ul style="list-style-type: none"> Modify the existing Dewatering and Drying Building to accommodate a different solids dryer technology or a redundant dryer by expanding the Dewatering and Drying Building to accommodate a second solids paddle dryer.

ES.8 Recommended Alternative

Figure ES.4 presents a WWTP site plan identifying locations of recommended improvements resulting from condition and capacity assessments, including evaluation of alternatives, as described.

Summaries of opinions of probable costs and anticipated phasing for the improvements recommended for inclusion in the City's WWTP CIP are provided in Table ES.10.

The expected cash flow for the planning period was determined for the recommended improvements summarized in Table ES.10. The cash flow through 2045 includes an escalation rate of three percent, and the peak expenditure is approximately \$13,906,000 in fiscal year 2031. The projected CIP expenditures are presented in Figure ES.5.

Table ES.10 WWTP Recommended Alternative Opinion of Probable Cost and Phasing

Plant Area	Project ⁽¹⁾	Opinion of Probable Cost	Approximate Year Online
Solids Handling	Dewatering Performance Optimization	\$150,000	2023
Communications/IT	Fiber Optic Cable Addition	\$55,000	2023
UV System	Trojan 4000 UV System Improvement	\$1,650,000	2024
Support Buildings	Seismic Improvements	\$1,015,000	2024
Secondary Treatment	New Secondary Clarifier Mechanisms	\$1,665,000	2026
Solids Handling	Solids Dryer Improvement	\$16,100,000 ⁽⁶⁾	2031
Solids Handling	Existing Centrifuge Replacement	\$2,200,000 ^(3,5)	2033 ⁽⁴⁾
Secondary Treatment	New Aeration Blower	\$394,000	2035
Secondary Treatment	New Conventional Aeration Basin	\$7,895,000	2038
TOTAL		\$31,124,000	

Notes:

White rows indicate projects that are in the City's 5-year CIP and blue rows indicate projects that are outside the 5-year CIP window.

- (1) Details of each project can be found in Chapter 2 or Chapter 6 of this Master Plan.
- (2) The estimated opinion of probable costs include the construction costs plus Engineering, legal and administration fees (ELA, or soft costs). Details on the estimated project costs can be found in Chapter 2 or Chapter 6 of the plan, with the exception of costs for the backup UV system and centrifuges which are presented earlier in Chapter 7.
- (3) For budgeting purposes, the Option B centrifuge cost from Table 7.4 is used for the project cost summary and the CIP
- (4) Replacement timing dependent upon satisfactory equipment performance
- (5) The centrifuges installed with the City's 2014 upgrade project have exhibited inconsistent performance in recent months. The City recently refurbished these units and expects they will provide sufficient capacity through 2045. However, by that time, the units will have been in service for over 30 years. It is recommended the City plan for replacement of these units during the planning horizon of this Master Plan. Assuming replacement occurs in the mid-2030's the City should reassess capacity needs of those units beyond the 2045 horizon, consistent with the expected service life of the new equipment.
- (6) The existing solids dryer has sufficient capacity through 2045. As with the dewatering centrifuges, the dryer equipment will soon have been in operation for a decade. It is recommended the City plan for replacement of the dryer during the planning horizon of this Master Plan. The City plans to replace the existing dryer with a new piece of equipment using similar technology and potentially rehabilitate the existing unit to serve as a backup. See Alternative 2B, Chapter 6.

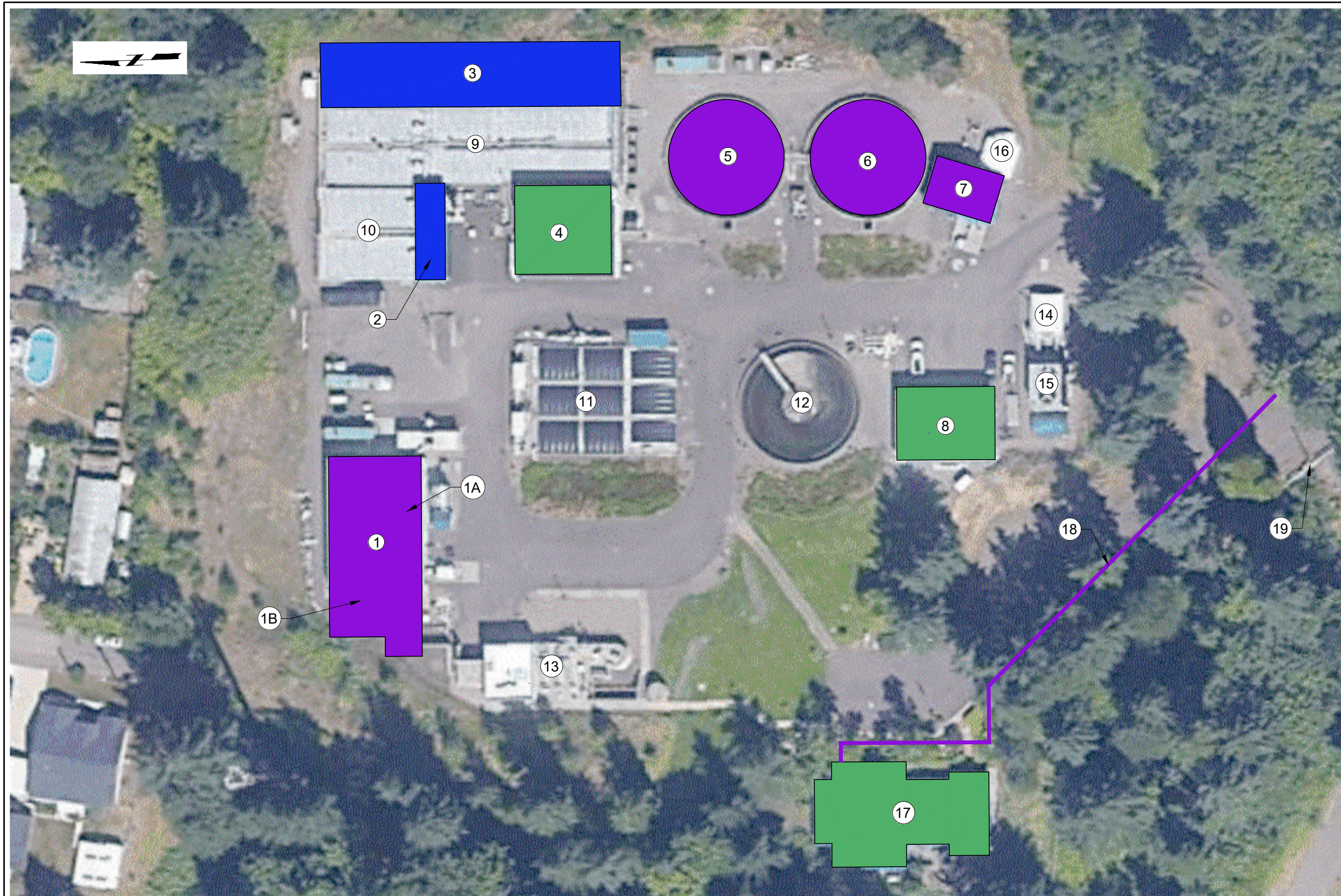

- LEGEND:**
- CONDITION OR ADDITION PROJECTS** [Purple Box]
- 1 - DEWATERING & DRYING BUILDING
 - 1A - EXISTING CENTRIFUGE REPLACEMENT
 - 1B - SOLIDS DRYER IMPROVEMENT
 - 5 - SECONDARY CLARIFIER NO. 1 - REPLACE MECHANISMS
 - 6 - SECONDARY CLARIFIER NO. 2 - REPLACE MECHANISMS
 - 7 - STANDBY UV SYSTEM REPLACEMENT
 - 18 - FIBER OPTIC CABLE ADDITION
- CAPACITY PROJECTS** [Blue Box]
- 2 - NEW AERATION BLOWER
 - 3 - NEW AERATION BASIN NO. 3, ACCESS IMPROVEMENTS & GRADING
- SEISMIC RETROFIT PROJECTS** [Green Box]
- 4 - PROCESS GALLERY
 - 8 - WORKSHOP
 - 17 - OPERATIONS BUILDING
- OTHER FACILITIES**
- 9 - SECONDARY PROCESS FACILITY
 - 10 - STABILIZATION BASIN
 - 11 - SLUDGE STORAGE BASINS AND BIOFILTERS
 - 12 - SECONDARY CLARIFIER NO. 3
 - 13 - HEADWORKS
 - 14 - DISK FILTERS
 - 15 - COOLING TOWERS
 - 16 - W3 REUSE PUMP STATION
 - 19 - SITE ENTRANCE

Plot Date: 6/3/2022 1:45:48 PM

FILE NAME: 11962A00_FIGURE_SEED.DWG

LAST SAVED BY: bhaves

0 30' 60' 120'
SCALE: 1" = 60'

Figure ES.4
PROPOSED WILSONVILLE WWTP IMPROVEMENTS
CITY OF WILSONVILLE



-This Page Intentionally Left Blank-

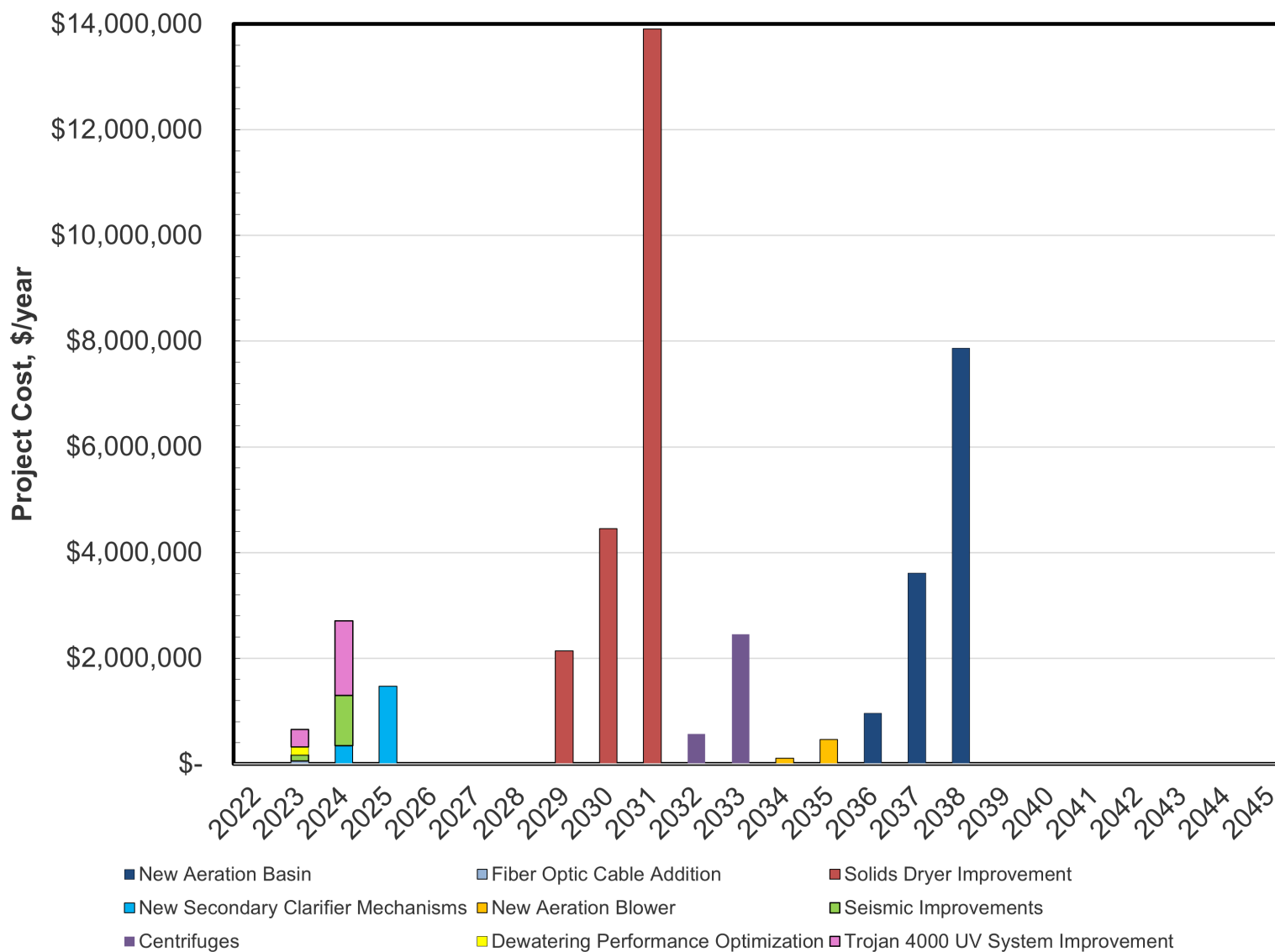

Figure ES.5 Projected 20-Year CIP Expenditures

-This Page Intentionally Left Blank-

City of Wilsonville Wastewater Treatment Plant Master Plan

Planning Commission

July 13, 2022





Master Plan Drivers

- City Capital Planning
- Accommodating Expected Growth
- Addressing Asset Condition and Replacement needs
- Assessing Potential Regulatory Drivers

Capital Planning and Expected Growth - 2045

- Current Service Area needs – 20+ years through 2045
 - Population and associated economic development

2015	2020	2030	2045
22,870	25,945	29,756	30,566

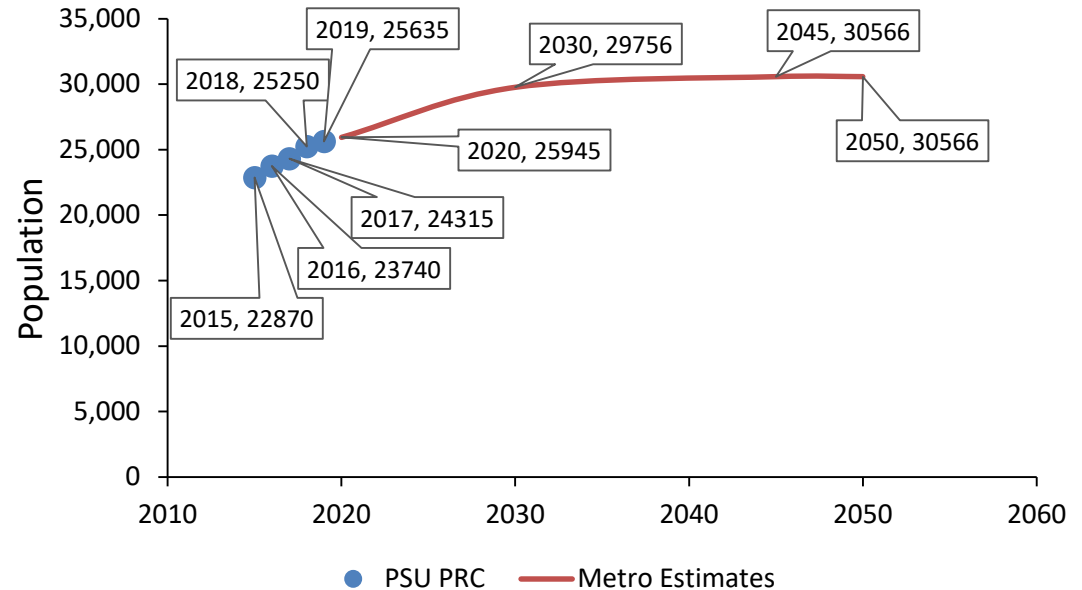



Facility Capacity Assessment

- Flows & Loads - Drive core process needs
- Existing WWTP design (2014 expansion) – ADWF – 4 mgd

Item	Existing	Projected 2045
Average Dry Weather Flow, mgd	1.94	2.68 (~38% > existing)
Average Annual Flow, mgd	2.24	3.03 (~35% > existing)
Maximum Month Wet Weather Flow, mgd	3.78	4.90 (~30% > existing)
Average Annual BOD ₅ , ppd	7,470	10,613 (~40% > existing)
Average Annual TSS, ppd	6,427	8,714 (~35% > existing)



Asset Condition Assessment

- Process Condition/Age Drivers
 - 2014 project facilities and equipment in service > 30 years by 2045
 - Solids facilities –
 - Performance issues
 - Solids Dryer fire (2019), component failures (2021), uneven performance
 - Solids Dewatering Centrifuges uneven performance (2020/21)
 - Secondary clarifiers – Pre-date 2014 upgrades, near term mechanism replacements, clarifiers no. 1 and 2
 - UV Disinfection – backup unit pre-dates 2014 upgrades, near term replacement



Potential Regulatory Drivers

- DEQ - Total Maximum Daily Load (TMDL)
Lower Willamette River
- Dissolved oxygen & nutrients
 - Nutrients can contribute to low oxygen conditions
 - Anticipate and accommodate future phosphorous, possibly nitrogen limits
- Pay attention to Willamette River
temperature concerns

Condition and Capacity Assessments



Condition Assessment

- Prioritize 2019 findings of consultant assessments
 - Secondary clarifiers
 - UV system
- Geotechnical and seismic evaluations
 - Older buildings found to present moderate risk
 - Identified mitigations to address seismic concerns
 - Operations Building
 - Process Gallery
 - Workshop

Unit Process Capacity Summary

Unit Process	Design Parameter	Redundancy Criteria	Possible Year of Capacity Exceedance	Identified Alternatives
Secondary Treatment	MW MLSS inventory @ PDF	All units in service	2038	<ul style="list-style-type: none"> • New Aeration Basin • New Secondary Clarifier
Aeration Blowers	Peak BOD Load	Largest unit out of service	2035	<ul style="list-style-type: none"> • Additional Blower
Disk Filters	MWDWF	One unit in backwash	2037	<ul style="list-style-type: none"> • Third Disc Filter • Relax DBO limits
Biosolids Dryer	MW Load	All units in service	>2045	<ul style="list-style-type: none"> • Emergency Biosolids Management Plan • Redundant Dryer, similar technology • Different Dryer technology

ALTERNATIVES EVALUATION



Alternatives Evaluation

- Consider alternatives for process units identified as capacity deficient
- Secondary Process
 - Add new Aeration Basin
 - Add new blower
- Tertiary Disk Filters
 - Relax DBO effluent TSS limits
- Solids Dryer – driven by performance, not necessarily capacity
- Process Gallery
 - Further study, placeholder to expand dewatering and drying building, add new paddle dryer, refurbish existing dryer (backup)

Alternatives Evaluation

- Solids Dryer – driven by performance, not capacity
 - Further study, placeholder to expand dewatering and drying building, add new paddle dryer, refurbish existing dryer (backup)
 - Largest potential investment in Master Plan

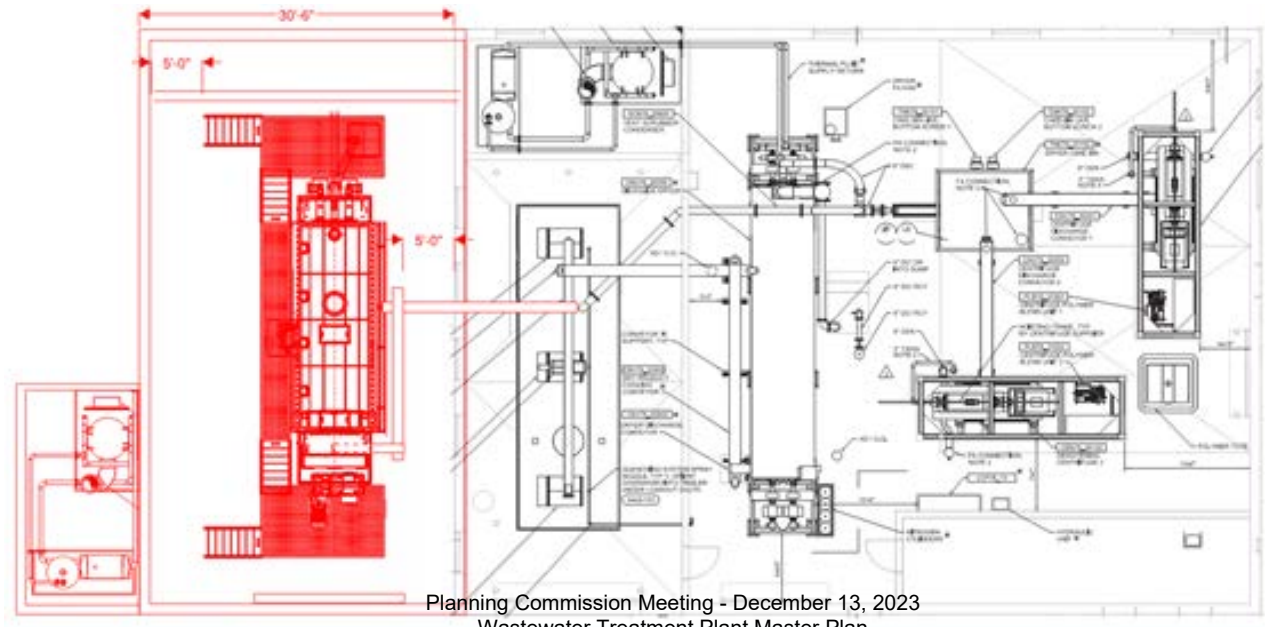

Recommended Plan

Recommended Plan

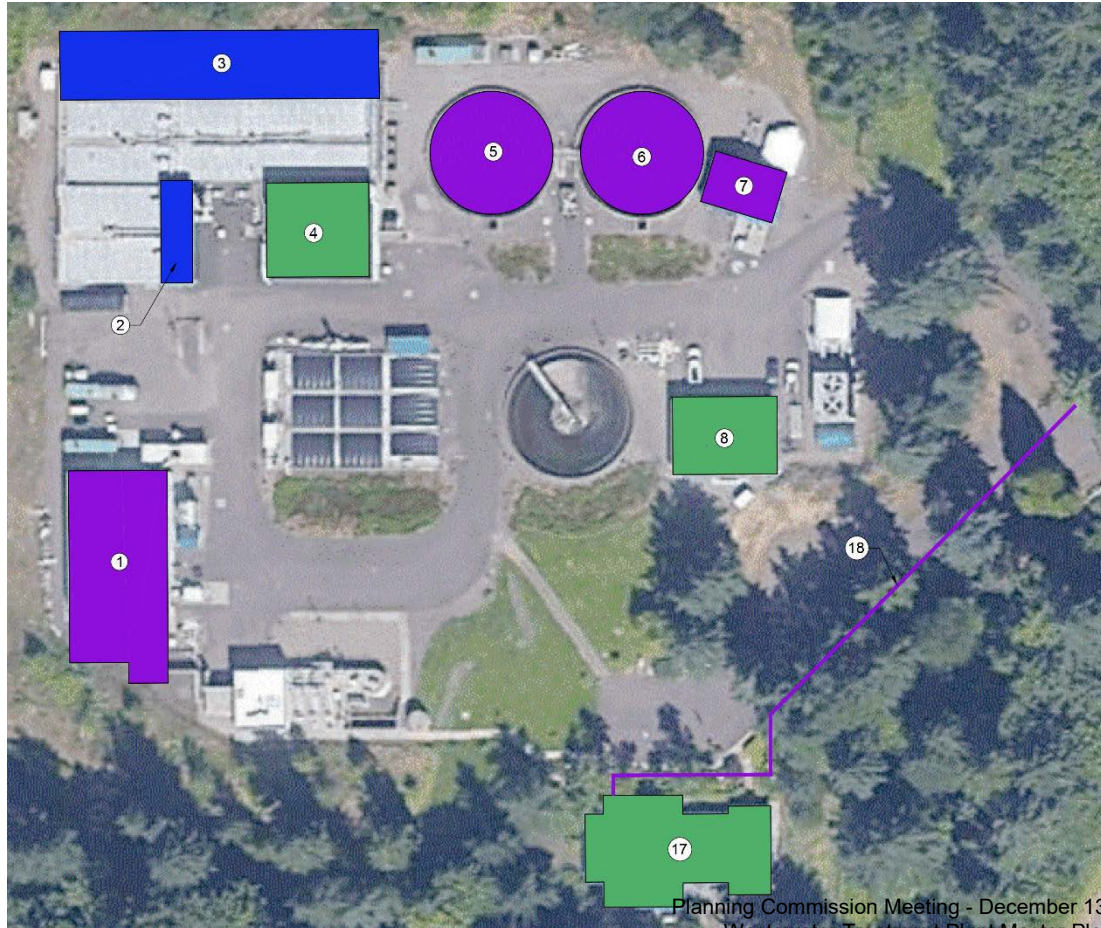

- ③ New Aeration Basin
- ② Additional Aeration Blower
- ⑦ Replace backup UV system
- ① Plan to replace Solids Dryer & Centrifuges
- ⑤ ⑥ Replace Clarifier 1 & 2 mechanisms
- ④ ⑧ Seismic retrofits of buildings
- ⑪ ⑫ ⑬ ⑭ ⑮ ⑯ ⑰ ⑱ ⑲ ⑳ ㉑ ㉒ ㉓ ㉔ ㉕ ㉖ ㉗ ㉘ ㉙ ㉚ ㉛ ㉜ ㉝ ㉞ ㉟ ㊱ ㊲ ㊳ ㊴ ㊵ ㊶ ㊷ ㊸ ㊹ ㊺ ㊻ ㊼ ㊽ ㊾ ㊿
- ⑱ New fiber optic connection

Solids process study

Proposed Project Phasing Schedule





Draft Cash Flow

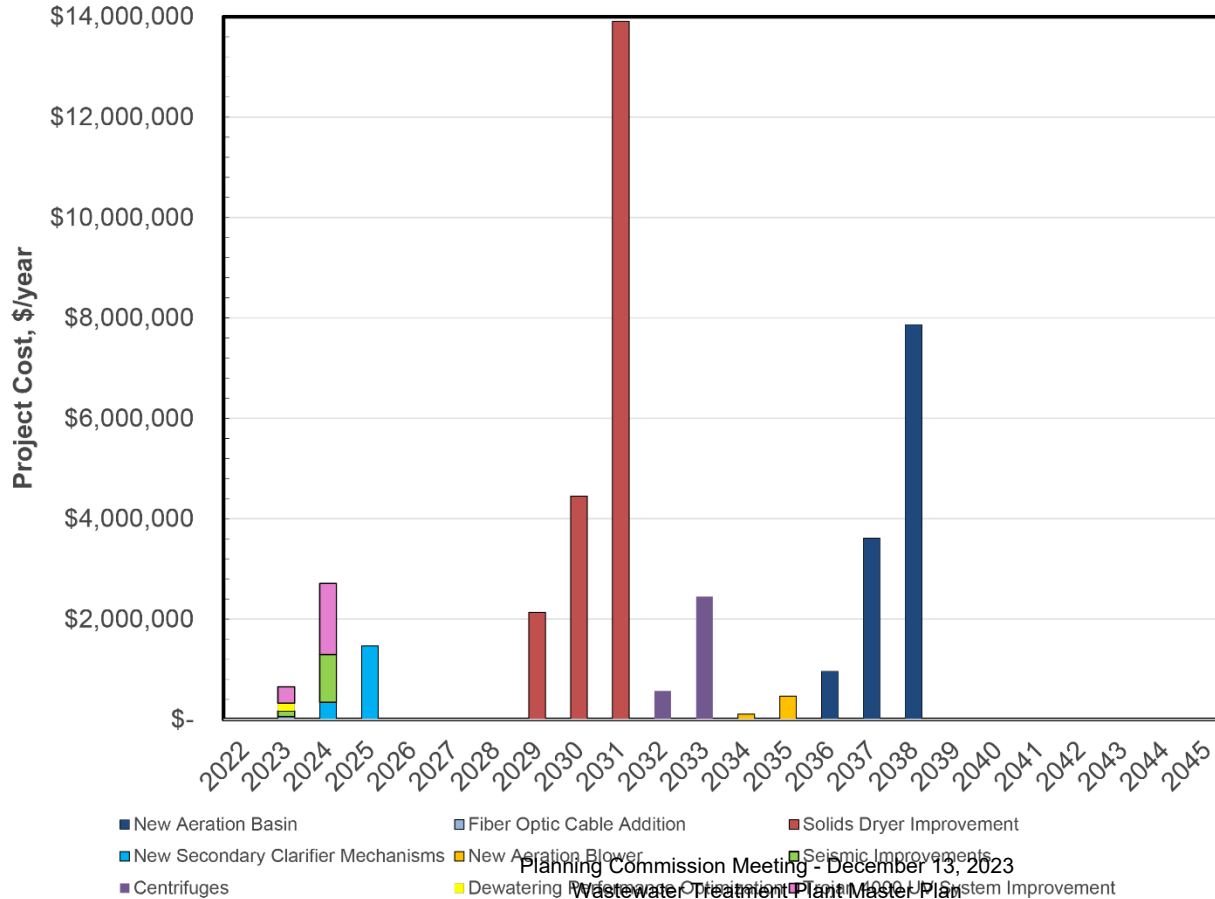

Planning Commission Meeting - December 13, 2023

Wastewater Treatment Plant Master Plan





Next Steps

- DEQ review and approval of Plan
- City Council Work Session 8/1
- Planning Commission Public Hearing 9/14
- City Council Public Hearing 1st Reading 10/3
- City Council 2nd Reading 10/17



**PLANNING COMMISSION
MEETING MINUTES
July 13, 2022 at 6:00 PM**

City Hall Council Chambers & Remote Video Conferencing

Attachment 4
Draft PC Minutes were reviewed and approved as corrected at the September 14, 2022 PC Meeting. Corrections are bold and underlined. Commissioner Gallagher moved to approve the July 13, 2022 minutes as corrected. Commissioner Karr seconded the motion, which passed unanimously.

CALL TO ORDER - ROLL CALL

A regular meeting of the Wilsonville Planning Commission was held at City Hall beginning at 6:00 p.m. on Wednesday, July 13, 2022. Chair Heberlein called the meeting to order at 6:01 p.m., followed by roll call. Those present:

Planning Commission: Ron Heberlein, Jennifer Willard, Aaron Woods, Andrew Karr, and Kamran Mesbah. Olive Gallagher arrived after roll call. Breanne Tusinski was absent.

City Staff: Daniel Pauly, Ryan Adams, Mike Nacrelli, and Mandi Simmons.

PLEDGE OF ALLEGIANCE

The Pledge of Allegiance was recited.

CITIZEN'S INPUT

This is an opportunity for visitors to address the Planning Commission on items not on the agenda. There was none.

ADMINISTRATIVE MATTERS

1. Consideration of the June 8, 2022 Planning Commission Minutes

The June 8, 2022 Planning Commission Minutes were accepted as presented.

WORK SESSION

2. Wastewater Treatment Plant Master Plan (Nacrelli)

Mike Nacrelli, Senior Civil Engineer, noted the Wastewater Treatment Plant Master Plan was the first since the last major upgrade to the Master Plan in 2012 and would look at the plant capacity, condition of the equipment, the regulatory landscape, and any issues that needed to be incorporated into a capital plan.

Dave Price, Project Manager & Vice President, Carollo Engineers, briefly highlighted his professional background. He presented the Wastewater Treatment Plant (WWTP) Master Plan via PowerPoint, noting Carollo based its planning around the City's Comprehensive Plan and the growth expected in the community through 2045 to ensure the treatment plant had capacity to treat in compliance with the NPDS permit to discharge to the Willamette River. Also reviewed were potential regulatory drivers, the WWTP condition and process capacity assessments, alternatives evaluation for addressing capacity deficiencies, as well as the recommended plan for new projects and infrastructure to provide additional capacity, the proposed phasing schedule, projected yearly cashflow, and next steps, which included the Master Plan's adoption anticipated in mid-October.

Discussion and feedback from the Planning Commission was as follows with responses to Commissioner questions as noted:

- Had the upcoming projects in 2023 and 2024 been estimated in the City's budget to provide the needed funding? (Slides 15 and 16)
 - Mr. Nacrelli replied the larger dollar amount projects, the UV System Improvement and Secondary Clarifier Mechanisms, were both in the Five-Year Plan of the recently adopted budget. The Seismic Improvements project could be accommodated in the City's Wastewater Capital Budget, and Staff would look into adding it to the Five-Year Plan in the next budget cycle. The Fiber Optic Cable Addition, at less than \$60,000, was a relatively small project. The Dewatering Performance Optimization project did **not** yet have a dollar amount and Staff would work with Jacobs Engineering Group Inc., the City's contract operator, to get that figure. The City might provide some funding through that operations contract, but the project would not have a major impact on the City's cash flow.
 - He confirmed a good amount of the near term proposed projects were in the Five-Year Plan, though a few things still needed to be addressed.
- What was the financing plan for 2031? Would funds come from CIP and is there adequate annual Capital Improvement Project (CIP) funding for the 2031 projects? (Slide 16)
 - Mr. Nacrelli noted the 2031 Solids Dryer Improvements project was the next big project. As mentioned in the Staff report, the current fiscal year budget identified a wastewater rate study and SDC analysis would be done in. The final Master Plan document would be used to see what the numbers and schedule meant for the monthly rates and the system development charges (SDCs) and how they might need to be adjusted. After the public hearings, over the next year, figuring out the finance plan would be the next step in implementation.
- Mr. Price clarified that grouting any soil voids around the existing piping was not part of the Seismic Improvements project but recommended in the geotechnical report and Northwest Geotech's study. When Northwest Geotech did its site work, no active erosion or piping was occurring; however, the City would need to pay attention to those requirements when doing the new improvements for the aeration basin, or if something was identified that appeared could be an issue, such as a hole showing up suddenly after some rain events. He did not know of anything to be worried about regarding the soils currently.
- Were there many complaints over odor and should the City do any projects to address odor?
 - Mr. Nacrelli responded he had not heard much about odor complaints from the operators at the site or from Delora Kerber, Public Works Director, who manages the contract.
 - Mr. Price added odor-control facilities were tied to the dryer and the solids building. He was not a solids processing expert, but there were risks when the process was interrupted and solids were not making it through the dewatering process to the dryer on a continual basis, which would occur because something broke or something else interrupted the normal flow. Under normal operations, the assumption was that the existing units were functioning as they were intended to control odor.
 - Mr. Nacrelli added he had not noticed any odor during his many times visiting the site.
- Mr. Nacrelli clarified the process for solids did not include a digester with gas harvesting, noting the digesters were eliminated with the last upgrade.
 - Mr. Price added there was no digestion, dewatered raw solids went from the centrifuge units right into the dryer unit, and that process was intended to function on a continual basis.
- Regarding plans for generating gas in the future, which was typical when dealing with solids, Mr. Nacrelli noted producing heat and electricity from harvested methane had been a big part of his previous job at

the City of Gresham, but it would be prohibitive for the City of Wilsonville to ~~try and~~ go back to using anaerobic digestion after eliminating the digesters.

- Mr. Price clarified that the percentage increases on Slide 4 were 2045 projections for an increase in the potential need for capacity based upon Staff's analysis using Metro numbers.
 - On how the percentage projections compared to the population increase percentage, Mr. Price replied the projected population of 30,000 in 2045 (Slide 3) was less than those represented in the table. (Slide 4) Often, conservative numbers were used when evaluating specific elements, like the loads or flows, for future growth and what would be produced. To ensure, Carollo was being conservative for planning purposes, the best-case scenario was not used. Every home built would not necessarily have the number of residents assumed by the Comprehensive Plan.
- The project assumed the same per capita load and flow generation seen today for 2045. The population increase would be around 18 percent, but the analysis showed increases of more than twice that in all categories. What infiltration inflow analysis information was available?
 - Mr. Price replied evaluations for treatment facilities looked at the actual flows received at the plant. Depending on the circumstance, the client's desires, and the needs of the community, the analysis might look at the collection system model to see the maximum amount of flow it could deliver. Typically, the flow numbers were generated based upon an evaluation using rolling averages, often a maximum month flow based upon a rolling 30-day average was used; not what the average was in one month compared to some time period, often it was the previous five years. The analysis did not necessarily utilize the same kinds of assumptions used in a collection system plan in part because with a treatment plant, no matter how tight the site was, the assumption was that more capacity could be built, expanded, or intensified. However, once pipe was put in the ground, it was difficult to make it any larger so often the collection system plan made very conservative assumptions, especially for peak flows it needed to convey to the plant to prevent wastewater protrusion from manholes.
- Did the City have a handle on clear water intrusion in the system?
 - Mr. Nacrelli replied the Wastewater Collection System Master Plan would have definitely looked at water intrusion and the Master Plan had a CIP to replace a lot of older pipes. He had been involved in several projects in Charbonneau, an older area where the age of the infrastructure had been a particular issue. The City was definitely addressing intrusion and the best way to do it was to either line or replace old pipes.
 - Commissioner Mesbah responded he had hoped to hear the City had a handle on any potential large inflow areas; not old pipes, but broken lines, especially in low areas with shallow ground water and he assumed some gravity lines were located where such water intrusion could occur, letting in water that was not efficient to treat. Was a conservation plan to reduce the loads in the future part of the WWTP Master Plan, assuming people would **not** be as wasteful as they were today?
 - Mr. Nacrelli noted the increases in BOD and TSS were a bit higher than the flows, which probably reflected that the influent was often trending stronger because less clean water, or rainwater, was coming into the system. The City was treating the same amount of solids, but the hydraulic impact was not as severe as it would have been in past years. (Slide 4) He agreed more efficient pipe materials, fixtures, and plumbing contributed to less water being treated.
 - A program to encourage more conservation would be more to do with the water distribution and plumbing side of things and was not part of this project's scope. However, the City was interested in conservation and pursuing it.
 - Mr. Price added one thing that came up with many of the planning studies he had done over the last 18 to 20 years was the idea that flows were very important, and they are however, as Mr.

Nacrelli had indicated, wastewater management tried to control the flow as well as ensure a process that could handle and treat the organic loads coming in, all of which included contaminants. In his experience, water conservation efforts did not always benefit wastewater treatment plants. For example, efforts in northern California, where constituents were regulated to a much lower level than DEQ, had resulted in the unintended consequence of water coming into the plants with a much higher concentration of pollutants. Water conservation was important, but it needed to be looked at carefully and watched at the wastewater plant, which was why the loads were looked at closely in the analysis which was often more important in some ways.

- Mr. Nacrelli noted the flows and loads increase was greater than the population increase and asked if that was because non-residential sources were also included.
 - Mr. Price confirmed the numbers did reflect non-residential sources, which included the prison and other industrial/commercial users within the service area, which were not reflected in the population numbers. Following Commissioner Mesbah's comments, he did want to take a hard look at the flows and loads analysis along with evolving land uses to make sure everything was in line.
- Industrial uses, like a brewery with higher loads to the treatment plant might exist in the city that the Commission was unaware of. Was the growth projection lowballed or would the City experience higher growth?
 - Mr. Nacrelli replied Metro's numbers were definitely on the low end, which was why they looked more closely at the medium projections indicated by the green line. (Slide 3, Green line)
- Historically, Metro numbers had been low, but the other aspect was that the City did have some say in how fast it grew. Some of the costs shown in the Draft Cash Flow chart were the costs of growth. (Slide 16) Perhaps those things should be thought about in addition to the expansion of load systems, etc. There were costs associated with choosing to grow which the City needed to be strategic about. The plan was conservative and seemed to have room to cover more than Metro's projections. Layering conservatism in the planning process should be avoided. Conservatism in facilities planning sometimes resulted in over-building unnecessarily that went unused long term.
 - Mr. Price replied that was a concern of his as well. Process engineers were conservative because no one wanted to under plan. The community should pay close attention to who was responsible for paying for which element of the need. Unfortunately, some elements might not be driven by capacity, but performance. There was an element of capacity embedded even in that large dryer unit that somebody would benefit from other than the existing users.
 - Mr. Nacrelli added because the City did not appear to have a capacity issue in the near-term, it could track what growth actually looks like over the next five years and then adjust accordingly, as the Master Plan would be adaptive. The City had not updated the Plan in 10 years, but he expected the City would not go longer than five years before assessing growth and making adjustments to the Master Plan as necessary.
- It would be helpful for the report to include a full built-out analysis. As the City built out areas it was adding, would it have adequate capacity, or would capacity go unused by the time the equipment needed to be replaced because it was not useful anymore; without having really used it? That would be a waste of taxpayer or ratepayer money. A full build-out analysis with timelines would provide some idea of whether the growth of the facility was being tracked in lockstep with the expected built-out of the areas added to the urban area.
 - Mr. Price noted the flows and loads had been projected out to the projection curves. Early in the analysis of the plant, Carollo Engineering, in conjunction with City Staff, decided not to necessarily

plan around the built-out numbers for the reasons pointed out. Including the build-out numbers would result in a more intense treatment plant site at the facility to account for the population nearly doubling, as shown by the projection on the higher rate curve. (Slide 3)

- Mr. Nacrelli clarified build-out was unrelated to the rate of growth. The current city boundaries and reserve areas would max out and fill up at some point according to how the areas were zoned. There was a number associated with build-out, though it was not necessarily tied to a time frame but to land use.
- Build-out could be tied to a time frame because the Planning Department had some idea of how fast the neighborhoods would develop. For example, 1680 units were planned for Town Center, 1750 units were planned in Frog Pond East and South. At 2.5 people per unit, 8500 residents would be living in developments the City knew were likely to be built between 2022 and 2035. Coffee Creek and Basalt Creek would likely be built out within a 20-year time period. While those were industrial uses, the City knew it would happen during the subject growth period.
- The expected growth chart should reflect the planning the City knew was already in progress. The city's population would increase from 27,000 to 37,000 just with the known development in Frog Pond East and South and Town Center, and that did not include Frog Pond West. The standard curve should include known development and another curve should address potential additional growth.
 - Additionally, the City should be explicit in its conservatism. Right now, the plan showed a 12 percent population growth from 2021 to 2045, but a 30 percent increase in load. The discrepancy between those two numbers should be explicit, especially as it the Master Plan progressed toward Council. The plan needed to be explicit in why the load increase was twice as much as the population growth, which was a big deal.
 - Mr. Nacrelli clarified Jacobs Engineering had taken over CH2MHill, the company that had the design/build/operate contract for the treatment plant, so Jacobs was now the City's contract operator for the treatment plant.
- As different population projections were done, Staff and the consultants were asked to use the same time frame for gathering historical data and for the future projection. For example, show 30 years' worth of previous data and then project 30 years into the future. A projection using 5 years of data to project 25 years in the future was not statistically defensible. The prior five years of growth could have been a growth spurt that was being extended 30 years into the future, which was not accurate. Growth, especially in a small city like Wilsonville, was choppy, so it should be averaged out to determine the long-term trends.

3. Frog Pond East and South Master Plan (Pauly)

Dan Pauly, Planning Manager, noted this was the Commission's sixth work session on the Frog Pond East and South Master Plan. He presented the Master Plan, including updates in response to the Commission's feedback via PowerPoint, reviewing the housing related design concepts and describing the similarities and differences between the three housing design types, displaying examples of each type using photographs from Villebois and Frog Pond West. He noted three housing design types were not set in stone, but the presentation addressed questions from Council and would be helpful for the Commission. Understanding the three housing types would be important in developing policy.

Joe Dills, MIG|APG continued the PowerPoint presentation, summarizing the feedback and preferences discussed by the Planning Commission last month, noting the aspiration to create and connect special destinations within the neighborhoods was still part of the physical planning. (Slide 29) He described the



The Boones Ferry Messenger

Monthly newsletter of the City of Wilsonville

September 2022

Open House Scheduled for Public Review of Waste Water Treatment Master Plan

The City of Wilsonville is conducting a virtual public open house to present the draft Wastewater Treatment Plant Master Plan, and to respond to questions and comments from community stakeholders.

The improvements detailed in this draft Plan are designed to provide optimal value to the City's ratepayers by maximizing the use of existing infrastructure and improving system operation while continuing to protect water quality and human health and supporting

**Waste Water Treatment Plant
Master Plan Open House**
Wed, Sept. 28, 7 pm
Zoom Virtual Meeting

economic development, consistent with goals and policies contained in the 2018 Com-

prehensive Plan and 2021-2023 City Council Goals.

The plan accounts for the age and condition of existing process equipment and structures as well as projected residential and commercial growth and potential regulatory changes.

To learn more about this project, review the draft Plan or attend the open house, visit letstalkwilsonville.com/wastewater-treatment-plant-master-plan or contact Mike Nacrelli, Senior Civil Engineer, at mnacrelli@ci.wilsonville.or.us.

PamplinMediaGroup

-Ad Proof-

This is the proof of your ad, scheduled to run on the dates indicated below. Please proofread carefully, and if changes are needed, please contact Sarah Penn prior to deadline at or spenn@pamplinmedia.com.

<p>Date: 09/20/22 Account #: 108863 Reference #: LP22-0001 Wastewater Treatment Plant Master Plan Company Name: WILSONVILLE, CITY OF Contact: Address: 29799 SW TOWN CENTER LOOP E WILSONVILLE Telephone: (503) 570-1510 Fax: (503) 682-1015</p>	<p>Ad ID: 258403 Start: 09/28/22 Stop: 09/29/22 Total Cost: \$206.38 Ad Size: 12.069 Column Width: 1 Column Height: 12.069 Ad Class: 1202 Phone # Email: spenn@pamplinmedia.com</p>
--	--

Run Dates:

Wilsonville Spokesman 09/29/22

**NOTICE OF LEGISLATIVE PUBLIC HEARING
BEFORE THE CITY OF WILSONVILLE
PLANNING COMMISSION AND CITY COUNCIL:**

**WASTEWATER TREATMENT PLANT (WWTP)
MASTER PLAN LP22-0001**

OREGON STATE LAW ORS 227.186. The City has not determined how or if this particular proposal will reduce or otherwise impact either the value or use of properties within Wilsonville. Any changes to permitted land uses may reduce or increase property values, depending on various factors. A written notice has been mailed to potentially impacted property owners as required.

PLANNING COMMISSION:

On **Wednesday, Oct. 12, 2022, beginning at 6 pm**, the Planning Commission will hold a public hearing on the **Wastewater Treatment Plant Master Plan**, and will consider whether to recommend to City Council adoption of the Plan.

You will not receive another mailed notice unless you: submit a request in writing or by phone, or submit testimony or sign-in at the hearing.

CITY COUNCIL:

On **Monday, Nov. 21, 2022 beginning at 7 pm**, the City Council will hold a public hearing regarding the Wastewater Treatment Plant Master Plan after which it may make the final decision.

The hearings will take place at Wilsonville City Hall, 29799 SW Town Center Loop East. A complete copy of the project record, including staff report, findings, and recommendations, will be available online and at City Hall for viewing 7 days prior to each public hearing.

SUMMARY OF PROPOSAL:

The City of Wilsonville is updating its Wastewater Treatment Plant Master Plan. The improvements detailed in this Plan are designed to provide optimal value to the City's ratepayers by maximizing the use of existing infrastructure and improving system operation while continuing to protect water quality and human health and supporting economic development.

The City's Wastewater Treatment Plant, along I-5 between the river and Old Town, was originally built in 1971. A major 2014 upgrade expanded the capacity to accommodate population growth.

This Plan, which satisfies requirements established by the State of Oregon Department of Environmental Quality (DEQ), considers:

- The age and condition of existing process equipment and structures
- Growth to accommodate population growth and new economic development over the planning period (through 2045). Projections are based on projections, historical data and DEQ wet weather project methodologies.
- Potential changes to water quality regulations established by the DEQ
- City of Wilsonville Wastewater Collection System Master Plan (2014), and
- Consistency with the 2018 Comprehensive Plan and City Council 2021-2023 Goals 5, 6 and 7

For more details, visit <https://www.letstalkwilsonville.com/wastewater-treatment-plant-master-plan>

HOW TO COMMENT:

Oral or written testimony may be presented at the public hearings. Written comment on the proposal is welcome prior to the public hearings. To have your written comments or testimony distributed to the Planning Commission before the meeting, it must be received by 2 pm on Oct. 4, 2022. Direct written comments to Mandi Simmons, Administrative Assistant 29799 SW Town Center Loop East, Wilsonville, Oregon, 97070 | msimmons@ci.wilsonville.or.us | (503) 682-4960

Note: Assistive Listening Devices (ALD) are available for persons with impaired hearing and can be scheduled for this meeting. The City will also endeavor to provide qualified sign language interpreters and/or bilingual interpreters, without cost, if requested at least 48 hours prior to the meeting. To obtain such services, please call Mandi Simmons, Administrative Assistant at (503) 682-4960.

Publish September 29, 2022

WS258403

PamplinMediaGroup

-Ad Proof-

This is the proof of your ad, scheduled to run on the dates indicated below. Please proofread carefully, and if changes are needed, please contact Sarah Penn prior to deadline at or spenn@pamplinmedia.com.

<p>Date: 10/05/22 Account #: 108863 Reference #: LP22-0001 Wastewater Treatment Plant Master Plan Company Name: WILSONVILLE, CITY OF Contact: Address: 29799 SW TOWN CENTER LOOP E WILSONVILLE Telephone: (503) 570-1510 Fax: (503) 682-1015</p>	<p>Ad ID: 260775 Start: 10/12/22 Stop: 10/13/22 Total Cost: \$33.02 Ad Size: 1.931 Column Width: 1 Column Height: 1.931 Ad Class: 1202 Phone # Email: spenn@pamplinmedia.com</p>
--	---

Run Dates:

Wilsonville Spokesman 10/13/22

**NOTICE OF CANCELLATION OF THE
LEGISLATIVE PUBLIC HEARING
BEFORE THE CITY OF WILSONVILLE
PLANNING COMMISSION AND CITY COUNCIL:**

The public hearing before the Planning Commission for the **Wastewater Treatment Plant Master Plan (LP22-0001)** scheduled for Wednesday, Oct. 12, 2022 at 6pm has been cancelled. We are sorry for the short notification.

The public hearing before the City Council for the Wastewater Treatment Plant Master Plan scheduled for Monday, Nov. 21, 2022 at 7pm has also been cancelled.
Publish October 12, 2022

WS258403

Simmons, Mandi

From: Thomas Hooker <thomas.hooker@gmail.com>
Sent: Sunday, October 2, 2022 4:57 PM
To: Simmons, Mandi
Subject: Wastewater Treatment Plant Master Plan Comment / Request

Follow Up Flag: Follow up
Flag Status: Completed

[This email originated outside of the City of Wilsonville]

Mandi,

Thanks you for allowing me to comment on the proposed WWTP. I am a resident of Wilsonville, having live here for 30+ years. I am generally in agreement with the plan and its goals. Owing and RV and watching our community grow over the years, I have often thought a city of our size should have a waste dump for residents with RV's. Our process now is go to Tigard or other areas to dump our RV's, adding addition travel time in high traffic areas. I would like to request that an RV Dump be added to the WWTP Master Plan to support our residents with RV's.

Using Tigard as an example, it could be a highly functional perk for our residents as well as generating money to support the cost through Automated Dump Fees (TYP. \$5.00 per Dump or \$250.00 annual fee).

Tigard Link:

<https://cleanwaterservices.org/community-home/resources/dispose/rv-waste/>

Thank you for your time.

Thomas Hooker
Park at Merryfield
Roland Ct.
thomas.hooker@gmail.com