

## Memo

<b>To</b>	Cindy Luxhoj, City of Wilsonville
<b>From</b>	Jennifer Arnold, Emerio Design
<b>CC:</b>	Amy Pepper, City of Wilsonville
<b>Date</b>	October 17, 2023
<b>Subject</b>	DB23-0012 Canyon Creek South Site Design Review of Tract A – Incompleteness Letter Response

Items listed in the October 5, 2023, incompleteness letter will appear in *italics*, followed by the applicant’s responses in regular typeface.

1. *Indication of how the concrete walk in the Tract A open space connects to the sidewalk in the public right-of-way. The pathway must be vertically or horizontally separated from the driveway in accordance with WC Section 4.154. The pathway must be ADA compliant. Submit a grading plan showing that the ADA pathway can be constructed as shown.*

**Applicant Response:** As included in Exhibit A, a grading plan showing pathway grades to demonstrate compliance with ADA standards. The driveway previously proposed at the public street has been changed to a 5 foot wide sidewalk that continues to Tract A.

2. *Materials detail or cut sheet describing the surface treatment (“exposed pea-gravel aggregate finish”) of the concrete walk.*

**Applicant Response:** A detail of the exposed aggregate concrete sidewalk has been included as Exhibit B to address this comment.

3. *Materials detail or cut sheet of the benches, picnic table, and any other site furnishings.*

**Applicant Response:** Included with Exhibit C are example images and detail sheets for both the picnic table and the benches. The example picnic table is intended to demonstrate material colors and materials but is not an ADA table as the detail specifies. The applicant proposes an ADA picnic table but had difficulty finding the appropriate image to match the detail.

4. *Materials detail or cut sheet of the perimeter/privacy fencing, indication of where the fence will be located around the open space, and explanation of why this is necessary.*

**Applicant Response:** See Exhibit F for fence detail information. The applicant has proposed constructing a fence along a portion of the southern boundary of Tract A to benefit the property owners on TL1100. The existing neighbor on TL 1200 has an existing wooden privacy fence and the applicant does not propose any change to that existing fence. This will create a continuous fence along the southern boundary of Tract A which will provide safety and privacy screening. This was not an agreement made based on a requirement of the Wilsonville Development Code but out of a good faith effort to work with the adjacent property owners given the ongoing disturbance associated with construction.

## Memo

---

- Sufficient information indicating where the SROZ and Impact Area boundaries are in relation to the Tract A open space improvements, and demonstrating impacts to the SROZ and buffer zone, if applicable, and proposed impact mitigation. Demonstrate that only native plantings are proposed in the SROZ and Impact Area, if any, in the Tract A open space.*

**Applicant Response:** The eastern boundary of Tract A is the SROZ boundary, but this overlay has an associated 25 foot buffer which projects into Tract A. Within the 25 foot buffer from the eastern boundary, the applicant proposes to plant one new tree (Western Dogwood native cultivar) and a mix of several native cultivar shrubs and perennial grasses. See the submitted landscape plan for plant details. No structures, walls, impervious surfaces, or disturbances are proposed within the SROZ buffer area and certainly not in the SROZ protection Tract approved with the subdivision approval. Invasive plants within Tract A such as Himalayan blackberry are proposed to be removed and replaced with non-invasive plant materials.

- Indication of water consumption categories for the plant materials on the landscape planting schedule.*

**Applicant Response:** Water consumption categories are included on the submitted landscape plan for each plant type. This information has been included on the Planting Schedule table on the landscape plan.

- Sufficient information demonstrating the project is or will be adequately served by stormwater, and that LID is used to the maximum extent feasible. Show how the new impervious area will be managed. Submit a Stormwater Report.*

**Applicant Response:** A stormwater report has been submitted with this application to demonstrate compliance with stormwater standards and to address this comment. See Exhibit E for stormwater report details.

- Sufficient information provided about easements and dedications. Show the stormwater pipeline easement, public pedestrian and bicycles access easement, tree protection and preservation easement, and stormwater maintenance and access easements on the plans. No trees should be planted in the stormwater pipeline easement.*

**Applicant Response:** No trees are proposed to be planted within the stormwater pipeline easement as shown on the landscape plan. The stormwater pipeline easement is shown on the submitted grading plan and included in Exhibit D. Exhibit D also includes the plat with all easements noted and the SROZ boundary as shown on the preliminary plat. Tract A is intended to be a public space with easements to provide legal access and use.

**Exhibits Included:**

Exhibit A: TRACT 'A' PATH & ADA RAMP GRADING PLAN & PROFILE  
Exhibit B: Materials Detail for Concrete Walk  
Exhibit C: ADA Table & Bench information  
Exhibit D: Plats  
Exhibit E: Stormwater & Drainage Report  
Exhibit F: Fence Detail  
Exhibit G: Narrative Site Design Review of Parks and Open Space\_REV1  
Exhibit H: Landscape Plan – Tract A

# Exhibit A

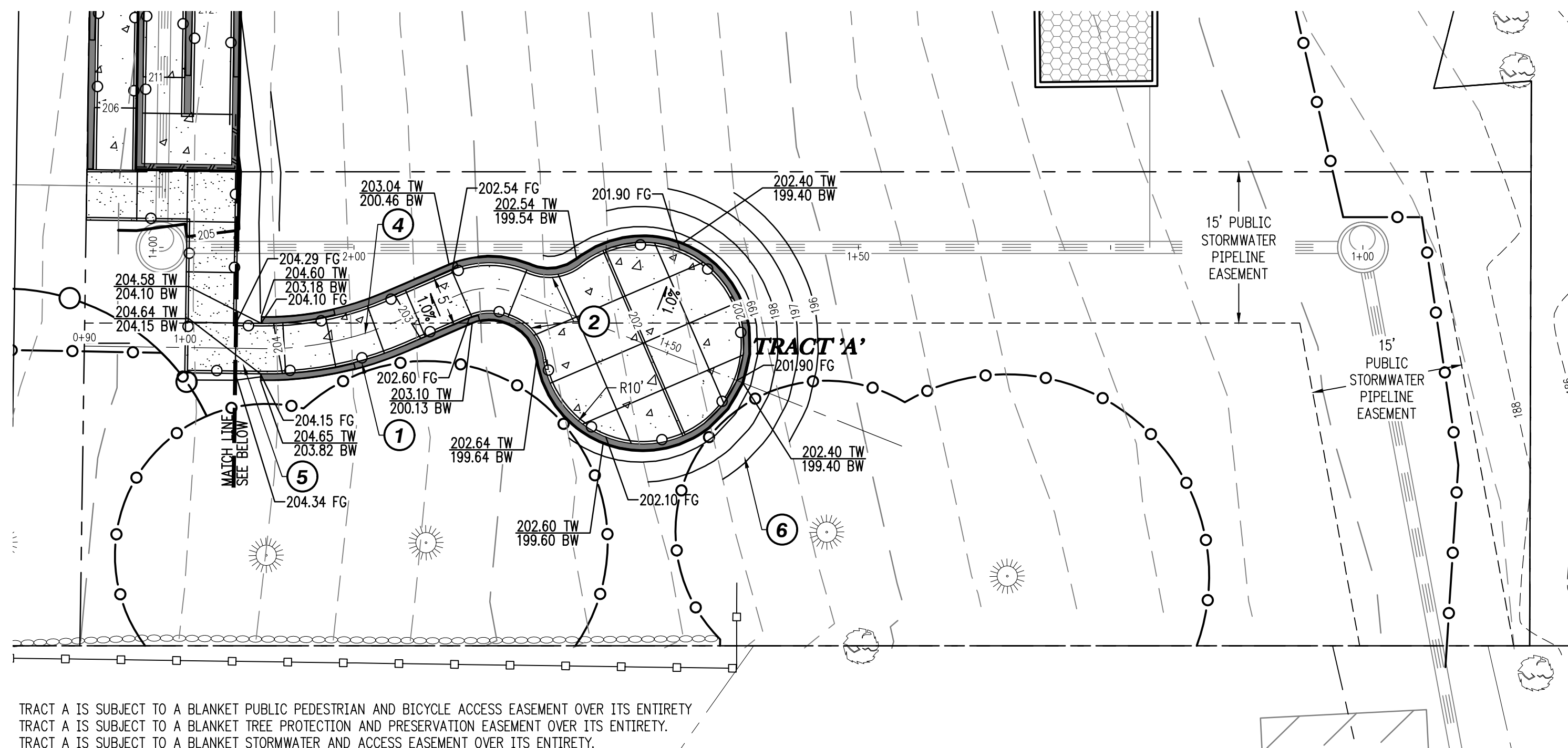

TRACT A IS SUBJECT TO A BLANKET PUBLIC PEDESTRIAN AND BICYCLE ACCESS EASEMENT OVER ITS ENTIRETY  
 TRACT A IS SUBJECT TO A BLANKET TREE PROTECTION AND PRESERVATION EASEMENT OVER ITS ENTIRETY.  
 TRACT A IS SUBJECT TO A BLANKET STORMWATER AND ACCESS EASEMENT OVER ITS ENTIRETY.

**TRACT 'A' GRADING - PLAN**

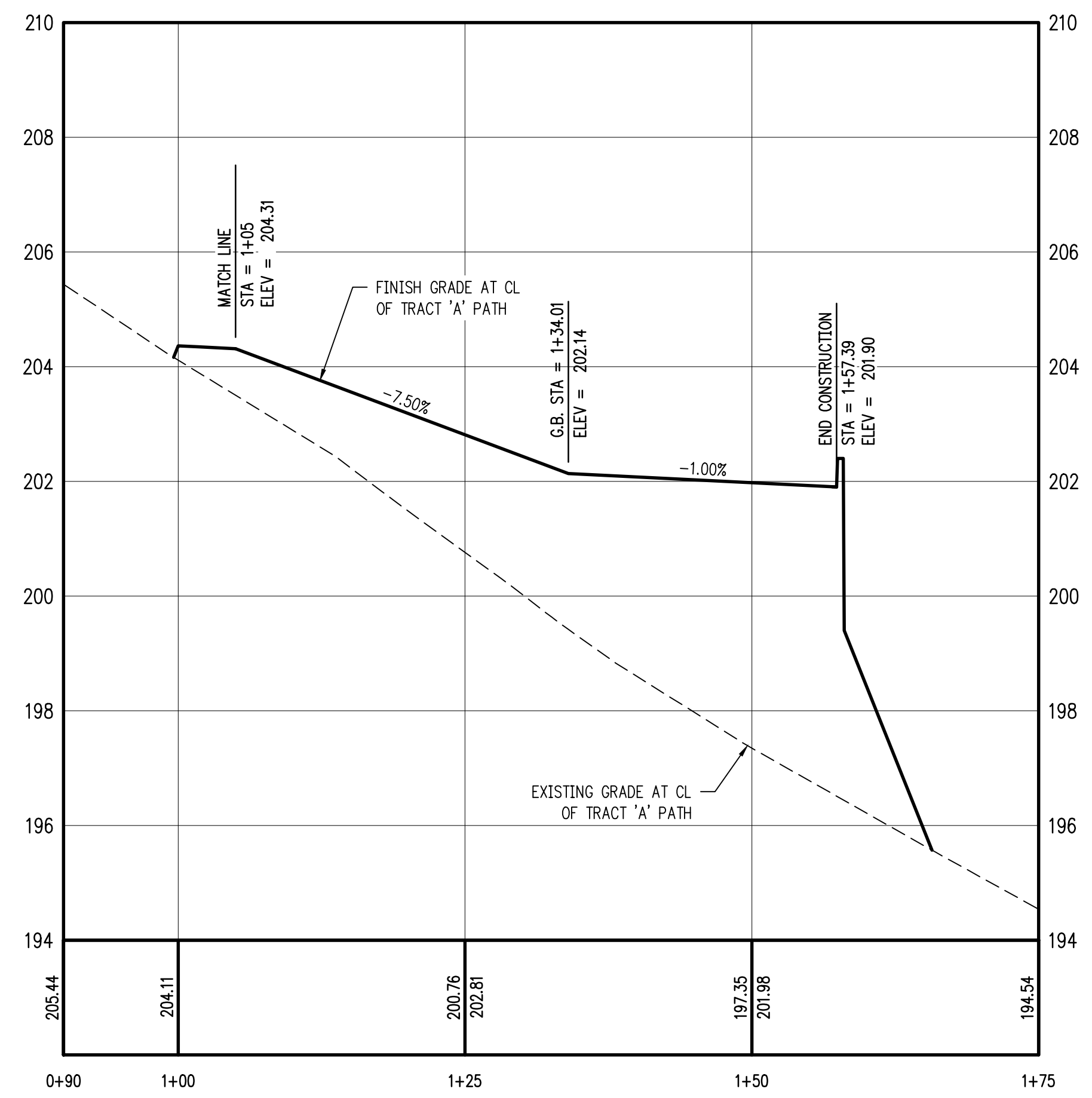
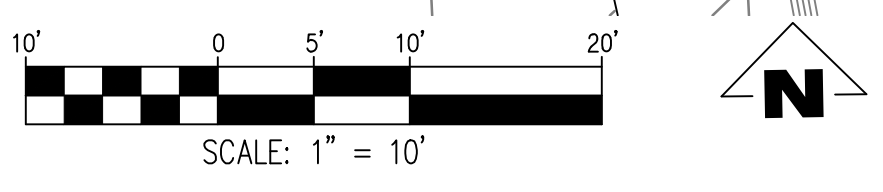

**TRACT 'A' PATH - PROFILE**

SCALE: 1"=10' HORZ. 1"=5' VERT.

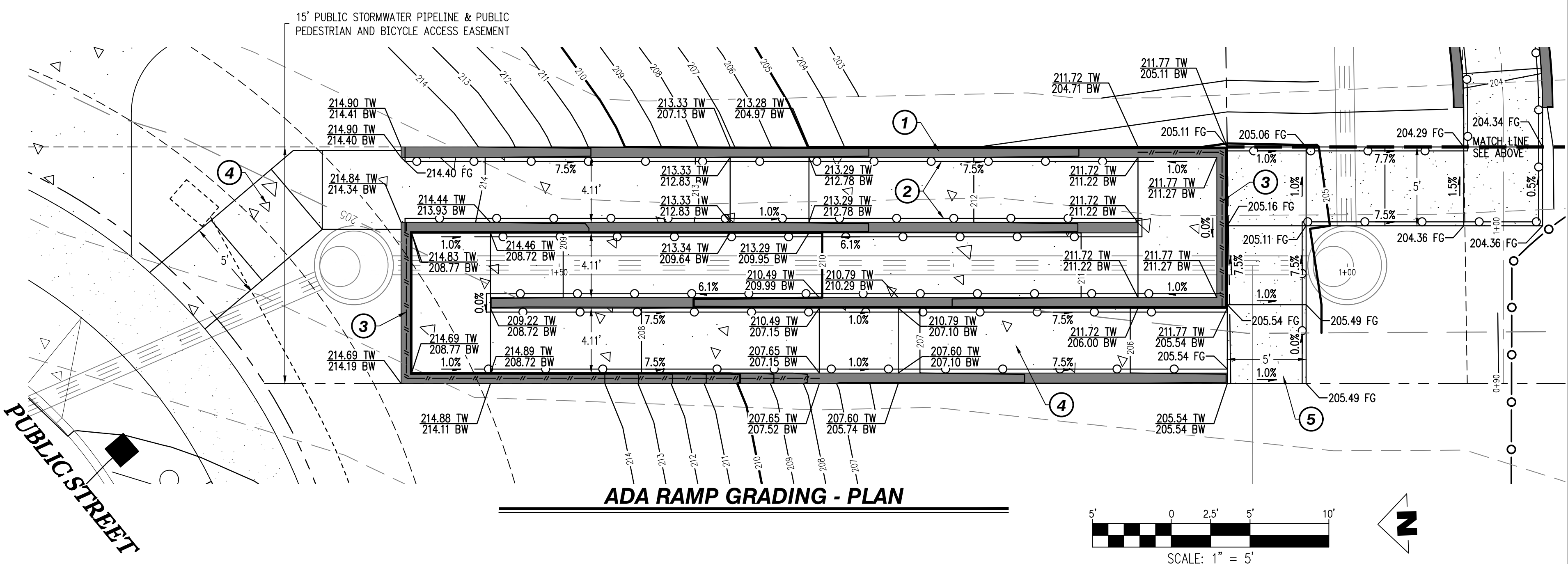

**ADA RAMP GRADING - PLAN**

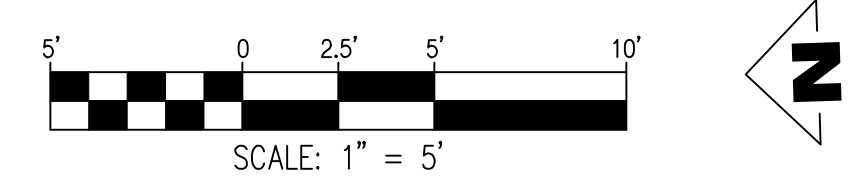

- CONSTRUCTION NOTES:**
- ① PROPOSED WALL
  - ② PROPOSED HANDRAIL
  - ③ PROPOSED GUARD RAIL WHERE WALL HEIGHT IS GREATER THAN 2.5'
  - ④ PROPOSED CONCRETE PATH
  - ⑤ PROPOSED PERVIOUS CONCRETE PATH
  - ⑥ ANY GRADING PROPOSED WITHIN TREE PROTECTION FENCING WILL BE DONE UNDER THE SUPERVISION OF THE PROJECT ARBORIST.

28700 CANYON CREEK RD S  
 TAX LOT 6400  
 TAX MAP 31W13BD  
 NW 1/4 OF SEC.13, T.3S R.1W W.M.  
 WILSONVILLE, OREGON

**TRACT 'A' PATH & ADA  
 RAMP GRADING PLAN &  
 PROFILE**

REVISIONS	
NO.	DESCRIPTION
1	DATE
2	12/16/21
3	03/30/22
4	05/02/22
5	05/04/22
6	09/12/22
7	11/01/22
8	01/05/23
9	07/26/23

**EMERIO**  
 ENGINEERING - SURVEYING - DESIGN  
 6445 SW FALLBROOK PLACE SUITE 100  
 BEAVERTON, OREGON 97008  
 TEL: (503) 748-8812  
 FAX: (503) 639-6592  
 www.emeriodesign.com



FILE: P:\0463-005\_Canyon Creek So Phase 3\0463-005\_TRACT, Layout: TRACT 'A' PATH & ADA RAMP GRADING PLAN & PROFILE, Plot Date: 10/23/2023 1:53 PM, by: Kyung Han

# Exhibit B

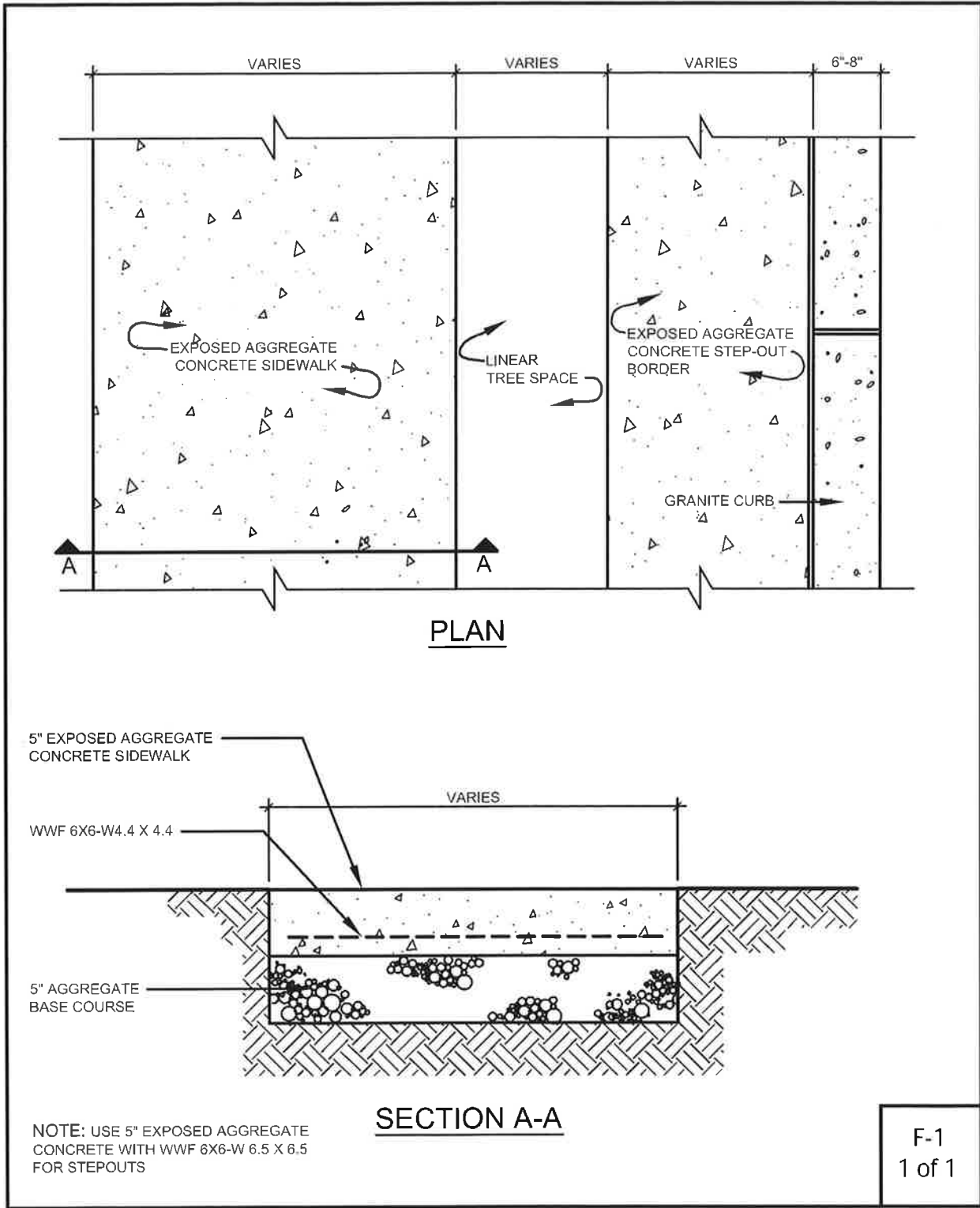
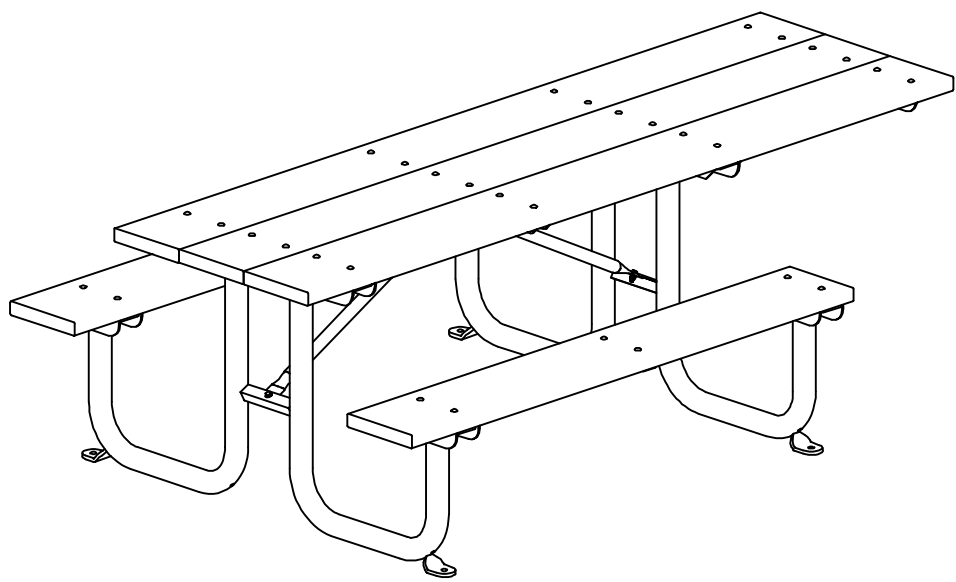
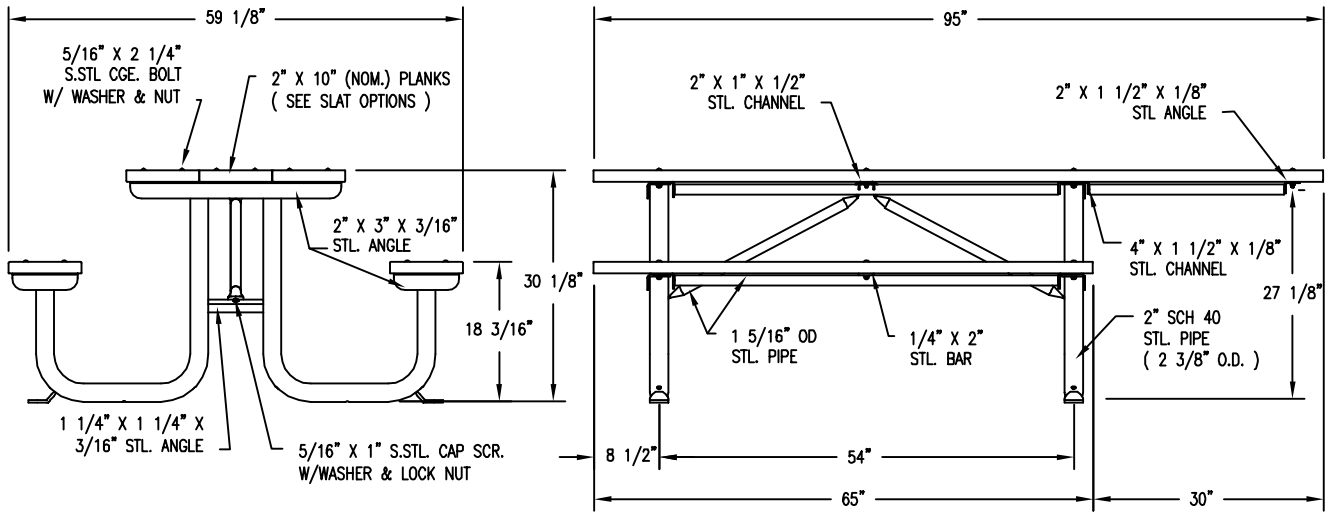

Figure 5: Sidewalk Detail—Exposed Aggregate Concrete

Interagency Initiative for National Mall Road Improvement

# Exhibit C



SLAT OPTIONS

- "CEDAR" RECYCLED PLASTIC
- "GREY" RECYCLED PLASTIC
- "REDWOOD" RECYCLED PLASTIC
- "WALNUT" RECYCLED PLASTIC
- OTHER \_\_\_\_\_

NOTES

1.) 1/2" X 3 3/4" EXPANSION ANCHORS PROVIDED.

FINISH OPTIONS:

- ALL STL. MEMBERS COATED W/ ZINC RICH EPOXY THEN FINISHED W/ POLYESTER POWDER COATING.
- HOT DIP GALV. AFTER FABRICATION.



PICNIC TABLE

DATE DRAWN : 03/22/94  
 DRAWN BY : CDC  
 DATE REV. : 01/11/17  
 REV. BY : RDH

REV.  
J

DRAWING  
NUMBER

77-68-1PL

SHEET  
1 OF 2



**NOTES:**

- 1.) DURING ASSEMBLY PROCEDURE;  
DO NOT COMPLETELY TIGHTEN HARDWARE.
- 2.) THE ACTUAL PARTS WILL NOT BE NUMBERED.  
NUMBERS ONLY APPLY TO DRAWING.
- 3.) UPON COMPLETION OF ASSEMBLY SQUARE  
ALL COMPONENTS THEN TIGHTEN ALL HARDWARE.
- 4.) MOUNT AND ANCHOR AS SPECIFIED.

**TOOLS REQ'D**

- 1/2" WRENCH
- 3/4" WRENCH
- 1/2" MASONRY DRILL BIT  
DRILL

**PARTS LIST**

ITEM	QTY	PART NO	DESCRIPTION
1	2	0-71-68-1PL-1	2" X 10" X 65" SLAT, PLASTIC
2	3	0-71-68-1PL-2	2" X 10" X 95" SLAT, PLASTIC
3	2	0-77-00-01	END SUPPORT FRAME
4	2	0-77-60-02	DIAGONAL BRACE FOR 6' TABLE
5	2	0-77-60-14	6' SEAT BRACE
6	1	0-77-68-1-15	TABLE TOP BRACE, HANDICAPPED
7	36	1-11-062	5/16" X 2 1/4" SS CGE BOLT
8	4	1-12-061	5/16" X 1" SS HEX HD CAP SCR
9	4	1-20-016	5/16" SS NYLON LOCKNUT
10	36	1-21-015	5/16" SS HEX NUT
11	44	1-22-017	5/16" SS FLAT WASHER

**KITS PROVIDED**

ITEM	QTY	PART NO	DESCRIPTION
12	1	K-77PL	77PL SER HARDWARE KIT
13	1	K-ANCO860-4	1/2" X 3 3/4" SS ANCHOR KIT (4PC)

- ① ATTACH SUPPORT FRAMES TO SLATS. BE SURE TABLE & SEAT BRACES ARE BETWEEN SLATS & SUPPORT FRAMES.

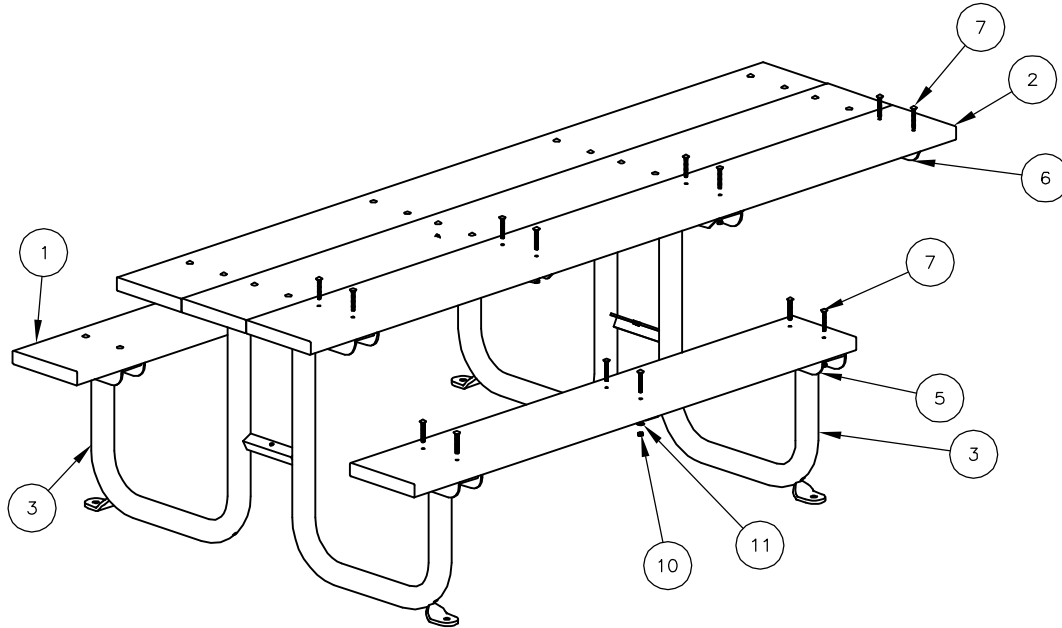

- ② ATTACH DIAGONAL BRACES TO STEP 1 ASSEMBLY.

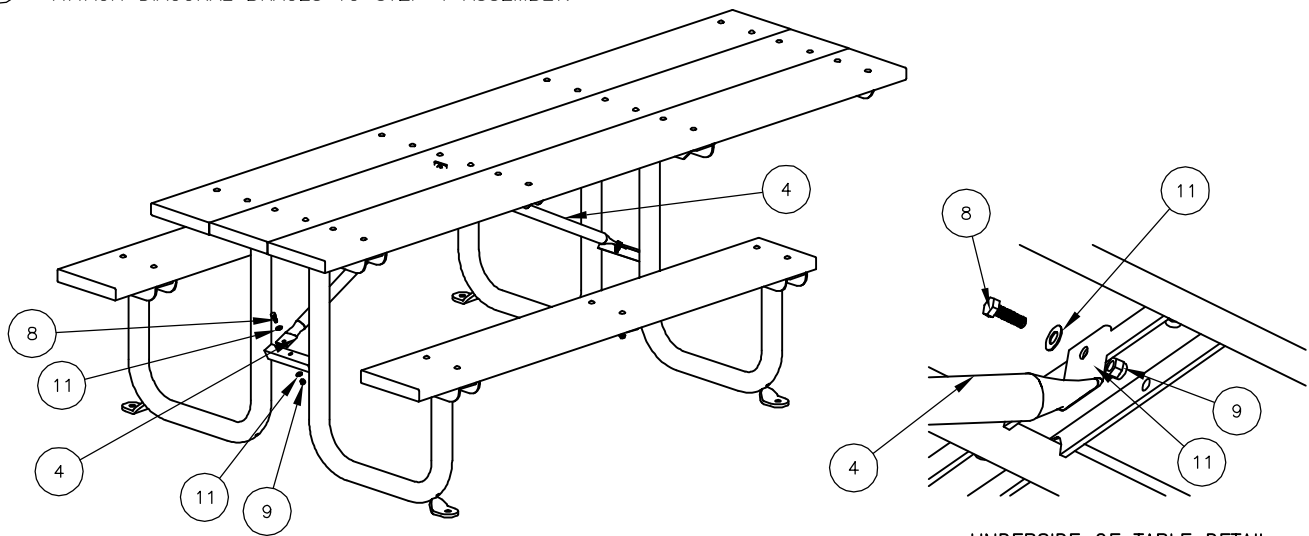

UNDERSIDE OF TABLE DETAIL

MID-STATE TRAIL



DeVito

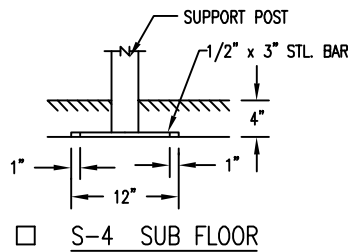
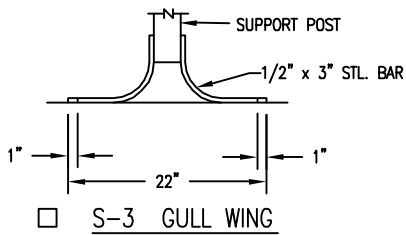
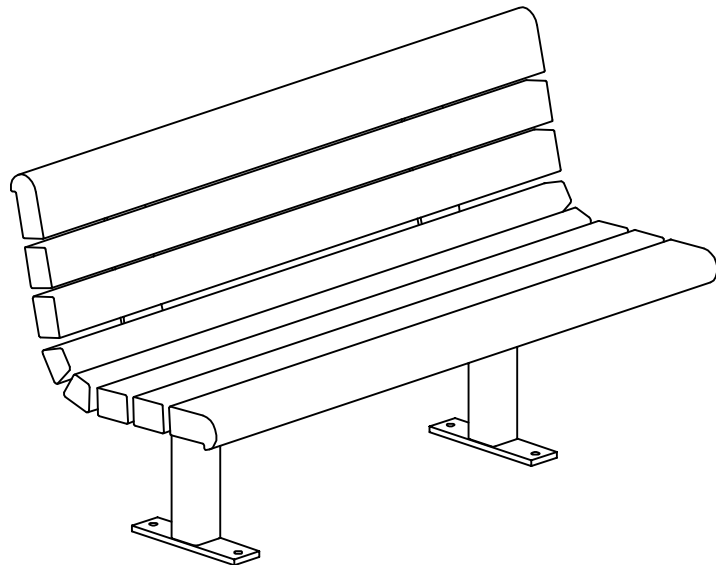
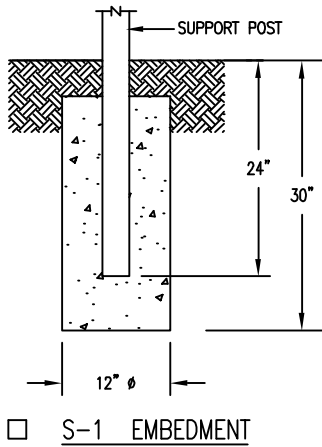
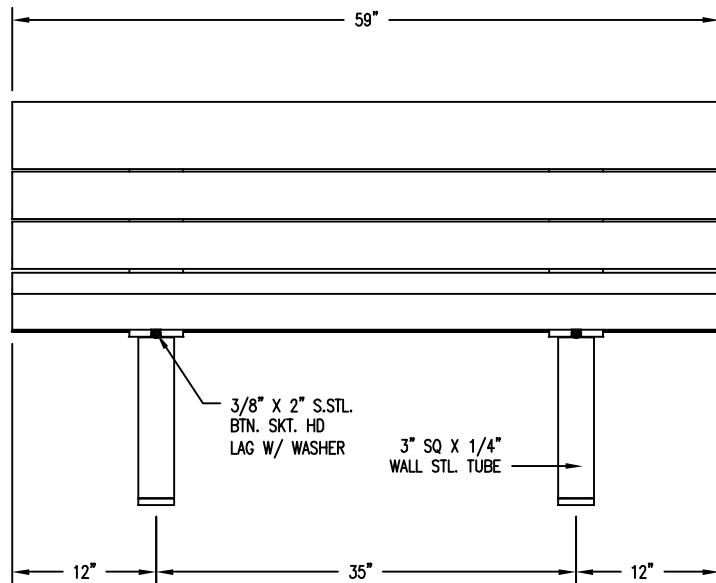
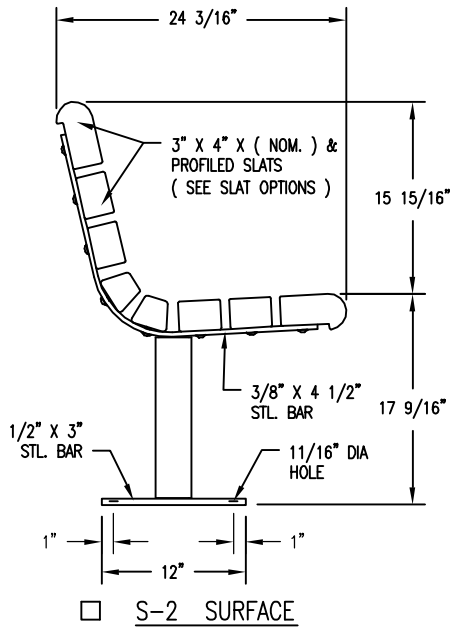

SLAT OPTIONS

- "CEDAR" RECYCLED PLASTIC
- "GREY" RECYCLED PLASTIC
- "REDWOOD" RECYCLED PLASTIC
- "WALNUT" RECYCLED PLASTIC
- OTHER \_\_\_\_\_

NOTES

- 1.) ALL STL. MEMBERS COATED W/ ZINC RICH EPOXY THEN FINISHED W/ POLYESTER POWDER COATING.
- 2.) 1/2" X 3 3/4" EXPANSION ANCHOR BOLT PROVIDED FOR S-2, S-3 & S-4 OPTIONS.

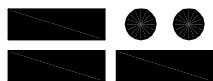

**DuMor, inc.**

P.O. Box 142 Mifflintown, PA 17059-0142

SCALE : NONE  
 DATE DRAWN : 8/6/96  
 DRAWN BY : HD  
 DATE REV. : 10/25/11  
 REV. BY : RDH

TITLE : BENCH

REV. E

DRAWING NUMBER

88-50PL

SHEET 1 OF 2

SURFACE MOUNT  
OPTION SHOWN

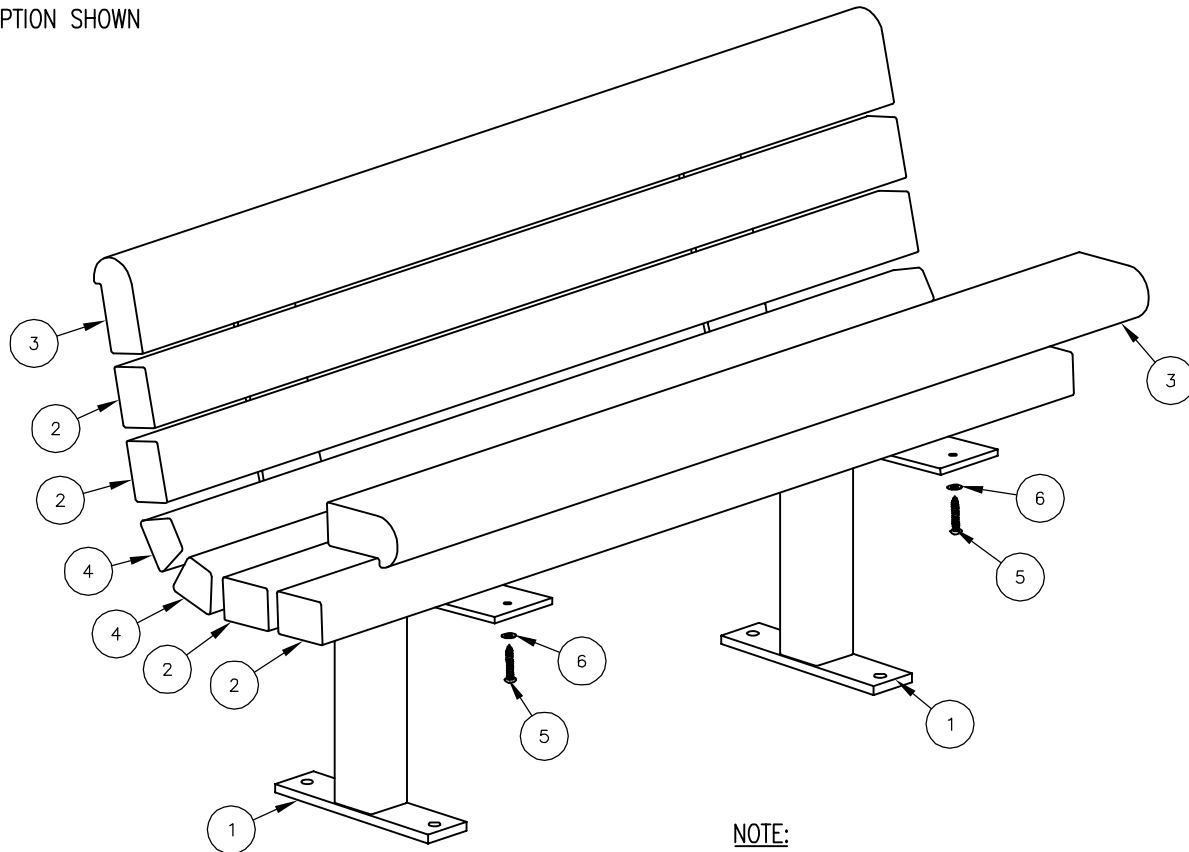

**NOTE:**

- 1.) DURING ASSEMBLY PROCEDURE;  
DO NOT COMPLETELY TIGHTEN HARDWARE.
- 2.) THE ACTUAL PARTS WILL NOT BE NUMBERED:  
NUMBERS ONLY APPLY TO DRAWING.
- 3.) SEE SPEC. SHEET 1 FOR MOUNTING OPTION.

**STEP 1:**

- USE 3 - PCS. SUPPORT FOR SURFACE MOUNT ( 1 )
- 4 - PCS. 3" X 4" X 59" PLASTIC INT'R SLAT ( 2 )
- 2 - PCS. 59" PLASTIC EDGE SLAT ( 3 )
- 2 - PCS. 59" PLASTIC TRAP SLAT ( 4 )
- 24 - PCS. 3/8" X 2" SS. BTN. SKT. HD. LAG SCR. ( 5 )
- 24 - PCS. 3/8" SS. FLAT WASHER ( 6 )

ATTACH SLATS ( 2, 3, & 4 ) TO SUPPORT FOR SURFACE MOUNT ( 1 ) USING HARDWARE ( 5 & 6 ). TIGHTEN TO SNUG FIT.  
REPEAT UNTIL ALL SLATS ARE ATTACHED.

**STEP 2:**

UPON COMPLETION OF BENCH ASSEMBLY SQUARE ALL COMPONENTS THEN TIGHTEN ALL HARDWARE.

**STEP 3:**

ANCHOR ACCORDING TO SUPPORT OPTION USED.

ITEM	QTY	PART NO	DESCRIPTION
1	2	0-88-00-01/S-2	BENCH SUPPORT FOR SURFACE MOUNT
2	4	0-88-50PL-02	3" X 4" X 59" PLASTIC SLAT
3	2	0-88-50PL-03	59" PLASTIC EDGE SLAT
4	2	0-88-50PL-04	59" PLASTIC TRAP SLAT
5	16	1-13-016	3/8" X 2" SS BTN SKT HD LAG SCR
6	16	1-22-024	3/8" SS FLAT WASHER

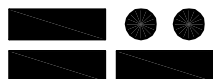

**DuMor, inc.**

P.O. Box 142 Mifflintown, PA 17059-0142

SCALE : NONE

DATE DRAWN : 8/6/96

DRAWN BY : HD

DATE REV. : 10/25/11

REV. BY : RDH

TITLE :

BENCH

REV.  
E

DRAWING  
NUMBER

88-50PL

SHEET  
2 OF 2



  
DUMEX

# Exhibit D

**Exhibit D: Preliminary Plat Showing SROZ Boundary**

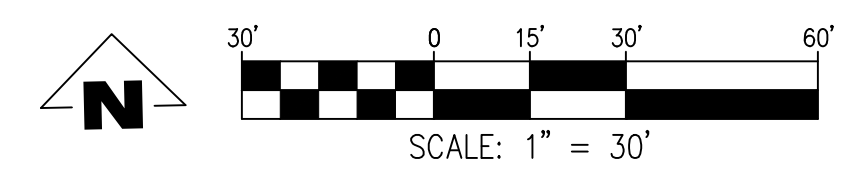
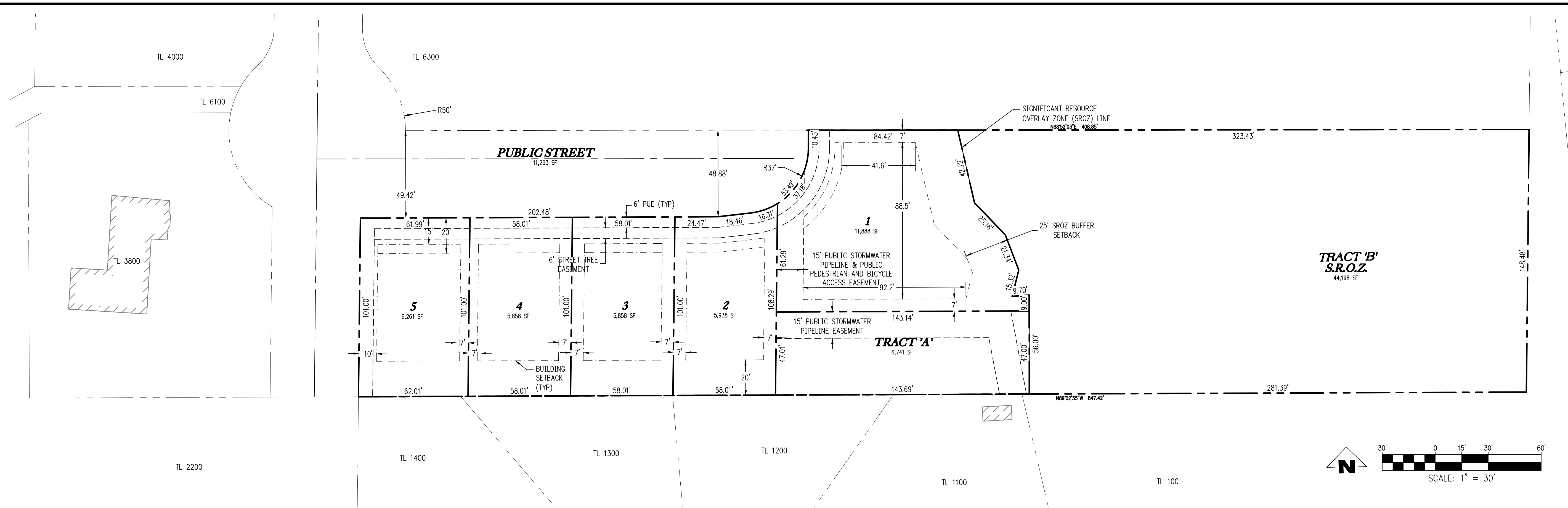

TRACT A IS SUBJECT TO A BLANKET PUBLIC PEDESTRIAN AND BICYCLE ACCESS EASEMENT OVER ITS ENTIRETY.  
 TRACT A IS SUBJECT TO A BLANKET TREE PROTECTION AND PRESERVATION EASEMENT OVER ITS ENTIRETY.  
 TRACT A IS SUBJECT TO A BLANKET STORMWATER AND ACCESS EASEMENT OVER ITS ENTIRETY.

PARCEL DATA	
AREA:	2.25 AC
PROPOSED ZONING:	PDR-3
TAX MAP:	31W13BD
TAX LOTS:	6400
NO. OF LOTS:	5

SITE DATA	
ZONE:	PDR-3
TOTAL SITE AREA:	2.25 ACRES (98,034 SQ. FT.)
NON-BUILDABLE AREA:	1.01 ACRES (44,198 SQ. FT.)
NET BUILDABLE AREA:	1.24 ACRES (53,836 SQ. FT.)
5 LOTS & 2 TRACTS	
MINIMUM LOT SIZE:	5,858 SQ. FT.
MAXIMUM LOT SIZE:	44,198 SQ. FT. (TRACT 'B')

TRACT 'A' DATA	
USABLE OPEN SPACE AREA:	0.15 ACRES (6,741 SQ. FT.)

MINIMUM SETBACKS	
FRONT:	15'
GARAGE:	20'
SIDE:	7' (5' SINGLE STORY)
REAR:	20'
MAX HEIGHT:	35'
MAX LOT COVERAGE:	
• 50% FOR LOTS CONTAINING LESS THAN 7,000 SQ. FT.	
• 45% FOR LOTS BETWEEN 7,000-8,000 SQ. FT.	
• 40% FOR LOTS EXCEEDING 8,000 SQ. FT.	
MIN LOT WIDTH:	40'

LEGEND	
	EXISTING SROZ LINE
	PROPERTY BOUNDARY
	PROPOSED LOT LINE
	PROPOSED RIGHT-OF-WAY LINE
	PROPOSED ROAD CENTERLINE
	PROPOSED PUE

28700 CANYON CREEK RD S  
 TAX LOT 6400  
 TAX MAP 31W13BD  
 NW 1/4 OF SEC.13, T.3S R.1W W.M.  
 WILSONVILLE, OREGON

PRELIMINARY PLAT

REVISIONS		
NO.	DATE	DESCRIPTION
1	12/16/21	1ST REVISION
2	03/30/22	2ND REVISION
3	05/02/22	3RD REVISION
4	05/04/22	4TH REVISION
5	09/12/22	5TH REVISION
6	11/01/22	6TH REVISION
7	01/05/23	ADDRESS CITY REVIEW COMMENTS
8	07/26/23	ADDRESS CITY REVIEW COMMENTS
9		STREET LIGHT REVISION

**EMERIO**  
 ENGINEERING • SURVEYING • DESIGN  
 6446 SW FALLBROOK PLACE, SUITE 100  
 BEAVERTON, OREGON 97008  
 TEL: (503) 748-8812  
 FAX: (503) 639-8592  
 www.emeriodesign.com



FILE: P:\0463-005 Canyon Creek So Phase 3\Wg\csl\0463-005\_05plat\_Layout: 05\_PRELIMINARY PLAT, Plot Date: 10/23/2023 1:49 PM, by: Kyung Han



**Exhibit D: Proposed Plat Showing Easements**

**SPRING TERRACE**

A REPLAT OF LOT 9, "BRIDLE TRAIL RANCHETTS" (PLAT NO. 1147)  
AND OTHER LAND LOCATED IN THE NORTHWEST 1/4 OF SECTION 13,  
TOWNSHIP 3 SOUTH, RANGE 1 WEST, WILLAMETTE MERIDIAN,  
CITY OF WILSONVILLE, CLACKAMAS COUNTY, OREGON  
OCTOBER 19, 2023

CITY OF WILSONVILLE CASE FILE NO. DB20-0045

**NARRATIVE**

THE PURPOSE OF THIS SURVEY IS TO SUBDIVIDE THE LAND DESCRIBED IN DOCUMENT NO. 2021-107591, CLACKAMAS COUNTY DEED RECORDS AS APPROVED IN CITY OF WILSONVILLE CASE FILE NO. DB20-0045. THE BASIS OF BEARINGS AND BOUNDARY DETERMINATION ARE PER SN2022-234.

REGISTERED  
PROFESSIONAL  
LAND SURVEYOR

*Jon T. Feigion 10/20/23*

OREGON  
JANUARY 15, 1987  
JON T. FEIGION  
2252

RENEWAL 12-31-23  
I HEREBY CERTIFY THAT THIS IS A  
TRUE AND EXACT COPY OF THE  
ORIGINAL PLAT.

- LEGEND**
- DENOTES SET 5/8" X 30" IR WITH YPC MARKED "EMERIO DESIGN", SET ON \_\_\_\_\_
  - △ DENOTES SET 5/8" X 30" IR WITH YPC MARKED "EMERIO DESIGN", SET ON \_\_\_\_\_
  - ✱ FOUND 5/8" IR WITH YPC MARKED "EMERIO DESIGN", SET IN R1
  - FOUND MONUMENT AS DESCRIBED IN MONUMENT REFERENCE TABLE
  - (H) HELD MONUMENT POSITION
  - [ ] MONUMENT FALLING
  - R2 SURVEY REFERENCE NUMBER
  - FD. FOUND
  - IR IRON ROD
  - YPC YELLOW PLASTIC CAP
  - SF SQUARE FEET
  - SN SURVEY NUMBER, CLACKAMAS COUNTY SURVEY RECORDS
  - DOC. NO. DOCUMENT NUMBER, CLACKAMAS COUNTY DEED RECORDS
  - PUE PUBLIC UTILITY EASEMENT
  - PSPE PUBLIC STORMWATER PIPELINE EASEMENT (SEE NOTE 3)
  - PBAE PUBLIC PEDESTRIAN AND BICYCLE ACCESS EASEMENT (SEE NOTE 6)
  - STE STREET TREE EASEMENT TO BENEFIT THE CITY OF WILSONVILLE
  - SROZ SIGNIFICANT RESOURCE OVERLAY ZONE

**MONUMENT REFERENCE TABLE**

- |   |   |
|---|---|
| 1 | FD. 1/2" IR, NO CAP, UP 0.8', SET IN R3                             |
| 2 | FD. 5/8" IR WITH YPC MARKED "EMERIO DESIGN" SET IN R10              |
| 3 | FD. 5/8" IR WITH YPC MARKED "SUMMERS P.L.S. 1042", FLUSH, SET IN R4 |
| 4 | FD. 5/8" IR WITH YPC MARKED "SUMMERS P.L.S. 1042", FLUSH, SET IN R4 |
| 5 | FD. 5/8" IR, NO CAP, DOWN 0.8', SET IN R2                           |
| 6 | FD. 5/8" IR WITH YPC MARKED "G&L LAND SURVEYORS, INC." SET IN R5    |
| 7 | FD. 5/8" IR, NO CAP, DOWN 0.7', SET IN R2                           |
| 8 | FD. 5/8" IR, NO CAP, DOWN 0.1', SET IN R3                           |

**REFERENCES**

- R1 SN 2022-234
- R2 SN 8185
- R3 PLAT OF "BRIDLE TRAIL RANCHETTS" (PLAT NO. 1147)
- R4 PLAT OF "SUNDIAL" (PLAT NO. 2910)
- R5 PLAT OF "RENAISSANCE AT CANYON CREEK SOUTH" (PLAT NO. 3978)
- R6 PARTITION PLAT NO. 2018-122

CURVE TABLE					
CURVE NO.	LENGTH	RADIUS	DELTA	CHORD BEARING	CHORD
C1	53.81	50.00	61°39'33"	N 30°56'18" E	51.25
C2	16.31	37.00	25°15'00"	N 71°59'58" E	16.71
C3	37.18	37.00	57°35'00"	N 30°35'03" E	35.64

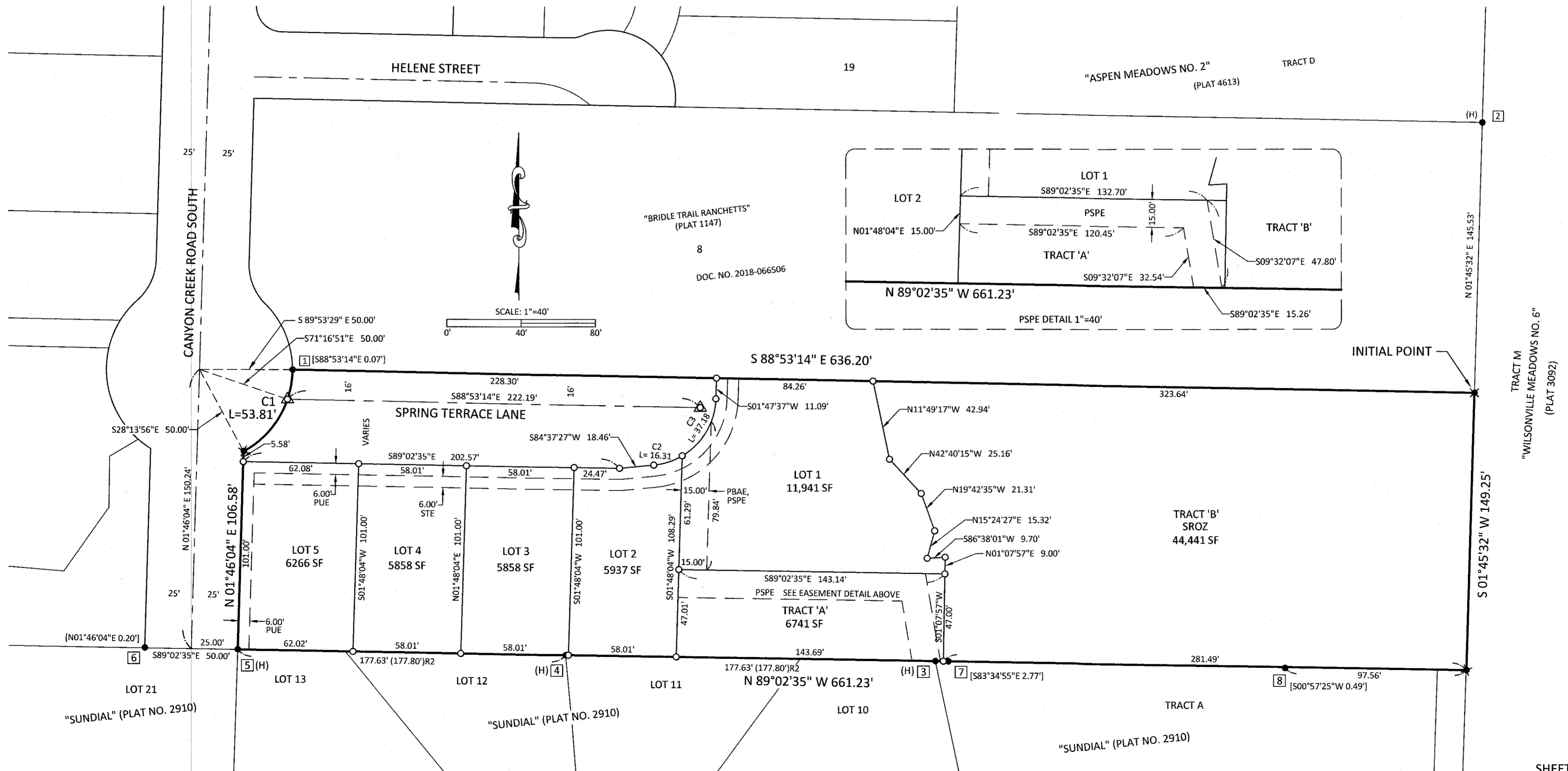

**SPRING TERRACE**  
 A REPLAT OF LOT 9, "BRIDLE TRAIL RANCHETTS" (PLAT NO. 1147)  
 AND OTHER LAND LOCATED IN THE NORTHWEST 1/4 OF SECTION 13,  
 TOWNSHIP 3 SOUTH, RANGE 1 WEST, WILLAMETTE MERIDIAN,  
 CITY OF WILSONVILLE, CLACKAMAS COUNTY, OREGON  
 OCTOBER 19, 2023

BOOK \_\_\_\_\_ PAGE \_\_\_\_\_

PLAT NO. \_\_\_\_\_

CITY OF WILSONVILLE CASE FILE NO. DB20-0045

**DECLARATION**

KNOW ALL PERSONS BY THESE PRESENTS THAT SAMM-MILLER, LLC, AN OREGON LIMITED LIABILITY COMPANY, IS THE OWNER OF THE LAND REPRESENTED ON THE ANNEXED MAP, BEING MORE PARTICULARLY DESCRIBED IN THE ACCOMPANYING SURVEYOR'S CERTIFICATE, AND HAS CAUSED THE SAME TO BE SUBDIVIDED INTO LOTS AND TRACTS IN ACCORDANCE WITH THE PROVISIONS OF O.R.S. CHAPTER 92, AND DOES HEREBY GRANT ALL EASEMENTS AS SHOWN OR NOTED HEREON.

SAMM-MILLER, LLC, AN OREGON LIMITED LIABILITY COMPANY

BY: \_\_\_\_\_  
 SCOTT JAMES MILLER, MANAGER

**ACKNOWLEDGEMENT**

STATE OF OREGON            )  
   )SS  
 COUNTY OF CLACKAMAS    )

THIS INSTRUMENT WAS ACKNOWLEDGED BEFORE ME ON \_\_\_\_\_, 20\_\_\_\_  
 BY SCOTT JAMES MILLER, MANAGER OF SAMM-MILLER, LLC, AN OREGON LIMITED LIABILITY COMPANY.

\_\_\_\_\_  
 NOTARY SIGNATURE

\_\_\_\_\_  
 NOTARY PUBLIC - OREGON (PRINT NAME)

\_\_\_\_\_  
 COMMISSION NO.

MY COMMISSION EXPIRES \_\_\_\_\_, 20\_\_\_\_

**PLAT NOTES**

- 1) THIS PLAT IS SUBJECT TO THE CONDITIONS OF APPROVAL PER CITY OF WILSONVILLE PLANNING CASE FILE NOS. DB20-0041, DB20-0042, DB20-0043, DB20-0044, AND DB20-0045.
- 2) A 6.00-FOOT WIDE STREET TREE EASEMENT FOR THE BENEFIT OF THE CITY OF WILSONVILLE SHALL EXIST ON LOTS 1-5 TO PLANT, REMOVE OR MAINTAIN APPROVED STREET TREES. LOTS 1-5 ARE SUBJECT TO A STREET TREE EASEMENT AGREEMENT PER DOCUMENT NO. \_\_\_\_\_, CLACKAMAS COUNTY DEED RECORDS.
- 3) A PORTION OF LOT 1 AND TRACT 'A' ARE SUBJECT TO A PUBLIC STORMWATER PIPELINE EASEMENT FOR STORMWATER PIPELINE ACCESS AND MAINTENANCE TO BENEFIT THE CITY OF WILSONVILLE.
- 4) TRACT 'A' IS AN OPEN SPACE TRACT AND IS OWNED BY THE SPRING TERRACE HOMEOWNERS' ASSOCIATION PER DOCUMENT NO. \_\_\_\_\_, CLACKAMAS COUNTY DEED RECORDS.
- 5) TRACT 'B' IS A SIGNIFICANT RESOURCE OVERLAY ZONE AS AS DEFINED BY CITY OF WILSONVILLE DEVELOPMENT CODE SECTIONS 4.139 THROUGH 4.139.11 AND IS SUBJECT TO A CONSERVATION EASEMENT AS RECORDED IN DOCUMENT NO. \_\_\_\_\_, CLACKAMAS COUNTY DEED RECORDS, FOR THE BENEFIT OF THE CITY OF WILSONVILLE, TO PRESERVE THE CITY'S MAPPED SIGNIFICANT RESOURCES.
- 6) A PORTION OF LOT 1 AND THE ENTIRETY OF TRACT A IS SUBJECT TO A PUBLIC PEDESTRIAN AND BICYCLE ACCESS EASEMENT.
- 7) THE ENTIRETY OF TRACT 'A' IS SUBJECT TO A BLANKET TREE PROTECTION AND PRESERVATION EASEMENT.
- 8) THE ENTIRETY OF TRACT 'A' IS SUBJECT TO A BLANKET PUBLIC STORMWATER MAINTENANCE AND ACCESS EASEMENT.

**SURVEYOR'S CERTIFICATE**

I, JON T. FEIGION, CERTIFY THAT I HAVE CORRECTLY SURVEYED AND MARKED WITH PROPER MONUMENTS, THE LANDS REPRESENTED ON THE PLAT OF SPRING TERRACE, BEING A REPLAT OF LOT 9, "BRIDLE TRAIL RANCHETTS" (PLAT NO. 1147), CLACKAMAS COUNTY PLAT RECORDS, AND OTHER LAND CONVEYED TO SAMM-MILLER, LLC BY DEED RECORDED IN DOCUMENT NO. 2021-107591, CLACKAMAS COUNTY DEED RECORDS, LOCATED IN THE NORTHWEST ONE-QUARTER OF SECTION 13, TOWNSHIP 3 SOUTH, RANGE 1 WEST, WILLAMETTE MERIDIAN, CITY OF WILSONVILLE, CLACKAMAS COUNTY, OREGON, BEING MORE PARTICULARLY DESCRIBED AS FOLLOWS:

BEGINNING AT THE INITIAL POINT, WHERE I FOUND A 5/8" IRON ROD WITH YELLOW PLASTIC CAP MARKED "EMERIO DESIGN" AT THE NORTHEAST CORNER OF THE TRACT OF LAND CONVEYED TO SAMM-MILLER, LLC BY DEED RECORDED AS DOCUMENT NO. 2021-107591, CLACKAMAS COUNTY DEED RECORDS, ALSO BEING ON THE WEST LINE OF TRACT "M", WILSONVILLE MEADOWS NO. 6" (PLAT NO. 3092), SAID INITIAL POINT BEARS SOUTH 01°45'32" WEST, 145.53 FEET FROM A 5/8" IRON ROD WITH YELLOW PLASTIC CAP MARKED "EMERIO DESIGN" AT THE SOUTHEAST CORNER OF TRACT "D", "ASPEN MEADOWS NO. 2" (PLAT NO. 4613);

THENCE ALONG THE EAST LINE OF SAID SAMM-MILLER TRACT AND THE WEST LINE OF SAID TRACT "M", SOUTH 01°45'32" WEST, 149.25 FEET TO THE SOUTHEAST CORNER OF SAID SAM-MILLER TRACT; THENCE ALONG THE SOUTH LINE OF SAID SAMM-MILLER TRACT AND THE NORTH LINE OF THE PLAT OF "SUNDIAL" (PLAT NO. 2910), NORTH 89°02'35" WEST, 661.23 FEET TO THE WESTERLY LINE OF SAID SAMM-MILLER TRACT, ALSO BEING THE EASTERLY RIGHT OF WAY LINE OF CANYON CREEK ROAD SOUTH (25.0 FEET FROM CENTERLINE);

THENCE ALONG SAID EASTERLY RIGHT OF WAY LINE, NORTH 01°46'04" EAST, 106.58 FEET TO A POINT OF NONTANGENT CURVATURE; THENCE 53.81 FEET ALONG THE ARC OF A NONTANGENT 50.00-FOOT RADIUS CURVE (THE RADIUS POINT BEARS NORTH 28°13'56" WEST) THROUGH A CENTRAL ANGLE OF 61°39'33" (THE CHORD BEARS NORTH 30°56'18" EAST, 51.25 FEET) TO THE NORTHWEST CORNER OF SAID SAMM-MILLER TRACT, BEING ON THE SOUTH LINE OF LOT 8, OF SAID "BRIDLE TRAIL RANCHETTS", THENCE ALONG THE NORTH LINE OF SAID SAMM-MILLER TRACT, SOUTH 88°53'14" EAST, 636.20 FEET TO THE INITIAL POINT.

SAID PLAT CONTAINS 98, 471 SQUARE FEET (2.26 ACRES), MORE OR LESS

REGISTERED  
 PROFESSIONAL  
 LAND SURVEYOR

*Jon T. Feigion* 10/20/23  
 OREGON  
 JANUARY 15, 1987  
 JON T. FEIGION  
 2252

RENEWAL 12-31-23

I HEREBY CERTIFY THAT THIS IS A  
 TRUE AND EXACT COPY OF THE  
 ORIGINAL PLAT.

**CONSENT AFFIDAVIT**

A SUBDIVISION PLAT CONSENT AFFIDAVIT BY ALERA MANAGEMENT GROUP, AN OREGON LIMITED LIABILITY COMPANY, BENEFICIARY OF THAT TRUST DEED RECORDED IN INSTRUMENT NO. 2022-038925, DATED JULY 6, 2022, CLACKAMAS COUNTY DEED RECORDS, HAS BEEN EXECUTED AND RECORDED IN INSTRUMENT NO.

\_\_\_\_\_, CLACKAMAS COUNTY DEED RECORDS.

**CITY OF WILSONVILLE APPROVALS**

CITY OF WILSONVILLE CASE FILE NO. DB20-0045

APPROVED THIS \_\_\_\_ DAY OF \_\_\_\_\_, 20\_\_\_\_

BY: \_\_\_\_\_  
 CITY OF WILSONVILLE PLANNING DIRECTOR

APPROVED THIS \_\_\_\_ DAY OF \_\_\_\_\_, 20\_\_\_\_

BY: \_\_\_\_\_  
 CITY OF WILSONVILLE COMMUNITY DEVELOPMENT DIRECTOR

**CLACKAMAS COUNTY APPROVALS**

APPROVED THIS \_\_\_\_ DAY OF \_\_\_\_\_, 20\_\_\_\_

BY: \_\_\_\_\_  
 CLACKAMAS COUNTY SURVEYOR AND CLACKAMAS COUNTY  
 BOARD OF COMMISSIONERS PER CODE CHAPTER 11.02

\*\*\*\*\*  
 ALL TAXES, FEES, ASSESSMENTS OR OTHER CHARGES AS PROVIDED  
 BY ORS 92.095 HAVE BEEN PAID THROUGH JUNE 30, 2023.

APPROVED THIS \_\_\_\_ DAY OF \_\_\_\_\_, 20\_\_\_\_

CLACKAMAS COUNTY ASSESSOR AND TAX COLLECTOR  
 BY: \_\_\_\_\_  
 DEPUTY

\*\*\*\*\*  
 STATE OF OREGON            )  
   )SS  
 COUNTY OF CLACKAMAS    )  
 I DO HEREBY CERTIFY THAT THE ATTACHED PLAT WAS RECEIVED

FOR RECORD ON THE \_\_\_\_ DAY OF \_\_\_\_\_, 20\_\_\_\_

AT \_\_\_\_ O'CLOCK \_\_\_\_ M.

AS PLAT NO. \_\_\_\_\_

DOCUMENT NO. \_\_\_\_\_  
 SHERRY HALL, CLACKAMAS COUNTY CLERK

BY: \_\_\_\_\_  
 DEPUTY



6445 SW FALLBROOK PLACE, SUITE 100  
 BEAVERTON, OREGON 97008  
 TEL: (503) 746-8812  
 FAX: (503) 639-9592  
 www.emeriodesign.com  
 EMERIO JOB: 0463-005

# Exhibit E



Stormwater Management Plan  
For Canyon Creek South Phase III  
5-Lot Subdivision  
Wilsonville, Oregon  
(TL 3800 & 6400, Tax Map 31W13BD)

Emerio Project Number: 0463-005  
City of Wilsonville Permit Number: PW21-0011  
Date: 07/08/2021  
Rev1: 09/23/2021  
Rev2: 11/18/2021  
Rev3: 08/15/2022  
Rev4: 09/28/2023



Prepared For:  
SAMM Miller LLC  
Scott Miller  
10211 SW Barber St.  
Wilsonville, OR 97070  
[smiller@marquiscompanies.com](mailto:smiller@marquiscompanies.com)

Prepared By:  
Roy Hankins, PE  
Emerio Design, LLC  
6445 SW Fallbrook PL, Suite 100  
Beaverton, Oregon 97008  
(541) 521-9797  
[roy@emeriodesign.com](mailto:roy@emeriodesign.com)

## **List of Appendices:**

### APPENDIX A – Site Information

- (1) Vicinity Map
- (2) Onsite Soils Maps – “Soils Survey for Clackamas County”
- (3) Curve Number Table
- (4) Infiltration Test Data and Email

### APPENDIX B – Storm Facility Sizing & Analysis

- (1) Basin Tabulated Area Spreadsheet
- (2) WES BMP Sizing Report
- (3) Proposed Conveyance Spreadsheet
- (4) Downstream Conveyance Spreadsheet
- (5) Conveyance HydroCAD Plots

### APPENDIX C – Site & Basin Maps

- (1) Pre-Developed Site Map
- (2) Post-Developed Basin Map
- (3) Proxy Treatment & Storm System Map
- (4) Downstream Basin Map
- (5) Downstream System Map

## **Project Overview and Description:**

Size and location of project site: The current site is located approximately 510 feet south of the intersection of Daybreak Street & Canyon Creek Road South on the east side of SW Canyon Creek Road South. The site will be developed into a 5-lot subdivision, which will include public street areas and an open space tract. The site is located at 28705 Canyon Creek Road South in Wilsonville, Oregon (Appendix A(1)).

Zoning: The property is zoned PDR3.

Type of Development: The proposed residential development will consist of a public street, a tract with an associated concrete pathway, and four new duplexes and a quadplex, each with associated driveways.

Existing vs. post-construction conditions: Currently the site is made up of two existing residential lots on opposite sides of Canyon Creek Road South. All onsite paved areas and buildings on tax lot 6400 are to be removed. In the post-developed condition, there will be 5 proposed onsite lots, four of which will contain duplexes, while the fifth will contain a quadplex. There will also be one open space tract, and a public street along the northern border of the site.

Watershed Description: The site currently sheet flows toward the south and east toward Boeckman Creek. In the post-developed condition, the onsite and ROW impervious areas flows will infiltrate into the local soil or route to an existing outfall into Boeckman Creek via proposed stormwater planters. Most flows will route to the outfall due to low infiltration rates. Onsite pervious areas and the concrete pathway on Tract A will sheet flow to the south and east towards Boeckman Creek in a similar flow pattern to the pre-developed site condition.

## **Soil Classification:**

The NRCS soil survey of Clackamas County, Oregon classifies the onsite soils as Aloha Silt Loam, Woodburn Silt Loam, and Xerochrepts and Haploxerolls. The associated hydrologic groups for these soils are C/D, C, and B respectively. As all construction aside from stormwater conveyance structures will occur in the Aloha Silt Loam and Woodburn Silt Loam areas, hydraulic soil group C will be used in this analysis. For the analysis of the proposed storm pipe network, a curve number of 86 will be used for pervious surfaces, and a curve number of 98 will be used for impervious surfaces. See Appendix A(2) for a soil classification map and A(3) for a curve number table.

## **Infiltration Testing:**

Onsite infiltration testing was conducted by Hardman Geotechnical Services. The recommended infiltration rate from the test results was 0.3 in/hr as an average of the two tested onsite infiltration rates. A factor of safety of 2.0 was applied to this recommended infiltration rate in the design of the proposed stormwater facilities. See Appendix A(3) for infiltration test data and emailed recommendations from the Geotechnical Engineer.

## **Treatment Methodology:**

Stormwater runoff will be addressed for this project by filtration planters and porous pavement, which will provide treatment and detention for the whole development. The City of Wilsonville approves the use of the WES BMP Sizing Tool to size the filtration planter facilities. Most proposed sidewalk and roadway areas will be treated by five filtration planters situated in the ROW. Four of these facilities will also manage runoff from impervious areas on lots 2, 3, 4, and 5. All five of these ROW planters will be unlined and

will allow for infiltration to the soil below. Impervious areas from lots 1 & 2 will be managed by individual lined filtration planters located on each lot, except for lot 2's driveway, which will route runoff to planter 4. All treated roof areas will route runoff to their respective planters via laterals. Sizing for the lot 2 planter assumes the total tributary impervious area is 2,750 SF per Wilsonville design standards for duplexes, while lot 1 uses the actual tributary impervious area as lot 1 contains a quadplex. All lot impervious areas routing runoff to the ROW planters will use actual impervious areas as the proposed homes develop more than 2,750 SF of impervious area per lot. All treatment areas are assumed to be 100% impervious. See Appendix B(1) for a list of all tabulated basin areas. See Appendix C(2) for planter locations and designations.

Due to ROW area restrictions, planters 4 & 5 will contain expanded, 30" deep growing mediums to reduce their required planter areas by 25%. This design modification allows the available planter areas to meet Wilsonville design standards. See the table below and Appendix B(2) for the sizing results.

A small section of new sidewalk and road area on the west side of the current Canyon Creek S cul-de-sac will go untreated. Most of the new pathway through Tract A will also go untreated. A section of roadway on the east side of the cul-de-sac to be maintained by grind and inlay paving will be proxy treated for most untreated areas in planters 1 & 2. In total, 1,633 of existing impervious area will be proxy treated for 526 SF of new sidewalk and road area, and 1,107 SF of pathway area on Tract A. The remaining 174 SF of new pathway area on Tract A will be constructed porous pavement to provide adequate stormwater management. See Appendix C(3) for a proxy treatment map.

Outlet pipes with flow control structures and overflow pipes will be provided for each public facility to route any stormwater that is not being infiltrated southeast to the outfall to Boeckman Creek.

See the following table for total combined basin areas going to each facility and both the required and provided planter sizes.

Basin ID	Facility ID	Total Basin Area (SF)	Facility Area Required (SF)	Facility Area Provided (SF)	Orifice Size (in)
A, B	Planter 1	2,949	118.0	171.1	0.5
C, D, E	Planter 2	6,057	240.8	243.0	0.7
F, G, H	Planter 3	5,634	225.4	278.8	0.7
I, J	*Planter 4	8,135	244.1	279.2	0.9
K	*Planter 5	629	19.0	19.0	0.2
M	Lot 1 Planter	5,815	407.1	408.0	0.7
L	Lot 2 Planter	2,750	192.5	193.0	0.5
N	Tract A Porous Pavement	174	N/A	N/A	N/A

\*The required facility areas are reduced by 25% due to the increased growing medium depths in Planters 4 & 5.

As shown in the table above, all proposed facilities were appropriately sized to meet water quality and detention standards. See Appendix C(2) for the basin delineation map and Appendix B(2) for the BMP sizing report.



### **Conveyance Analysis:**

All onsite post-developed storm drainage will route to proposed curb inlets or catch basins to enter the proposed storm system. Upstream areas will enter the storm system via proposed catch basins along Canyon Creek S.

The proposed storm conveyance system is a combination of 12" diameter storm pipes throughout the site. The proposed storm pipe systems will be designed to convey the 25-year, 24-hour design storm with rain intensity of 4.0 inches. HydroCAD v.10 was used to model all basin runoff quantities. Results indicate that all proposed storm pipes associated with development are appropriately sized and sloped to convey the post-developed storm drainage of the 25-year design storm under open channel flow conditions. See Appendix B(3) for the proposed stormwater conveyance spreadsheet, Appendix B(5) for the associated HydroCAD plots, Appendix C(2) for a conveyance basin map, and Appendix C(3) for a map of the analyzed new storm system.

### **Downstream Analysis:**

An analysis of the downstream system capacity was performed up to the point the developed onsite flows are less than 10% of the tributary flow.

The existing downstream storm system is a combination of 12" diameter storm pipes with slopes ranging from 0.40% to 40.80%. Downstream basins were delineated to determine the total tributary flows based on City of Wilsonville as-built and GIS data. HydroCAD v.10 was used to model all basin runoff quantities during the 25-year design storm. It was determined that the total onsite flow directly entering the downstream system (0.624 cfs) reaches less than 10% of the total tributary flow (11.961 cfs) in the existing pipe that outfalls to Boeckman Creek. Up to this point, all downstream segments were found to operate within capacity assuming open channel flow throughout the system. See Appendix B(4) for the proposed stormwater conveyance spreadsheet, Appendix B(5) for the associated HydroCAD plots, Appendix C(4) for a downstream basin map, and Appendix C(5) for a map of the analyzed storm system.

### **Conclusion:**

The design of the proposed site satisfies the stormwater design standards set by the City of Wilsonville.

## **Appendix A**

Appendix A(1)  
Vicinity Map

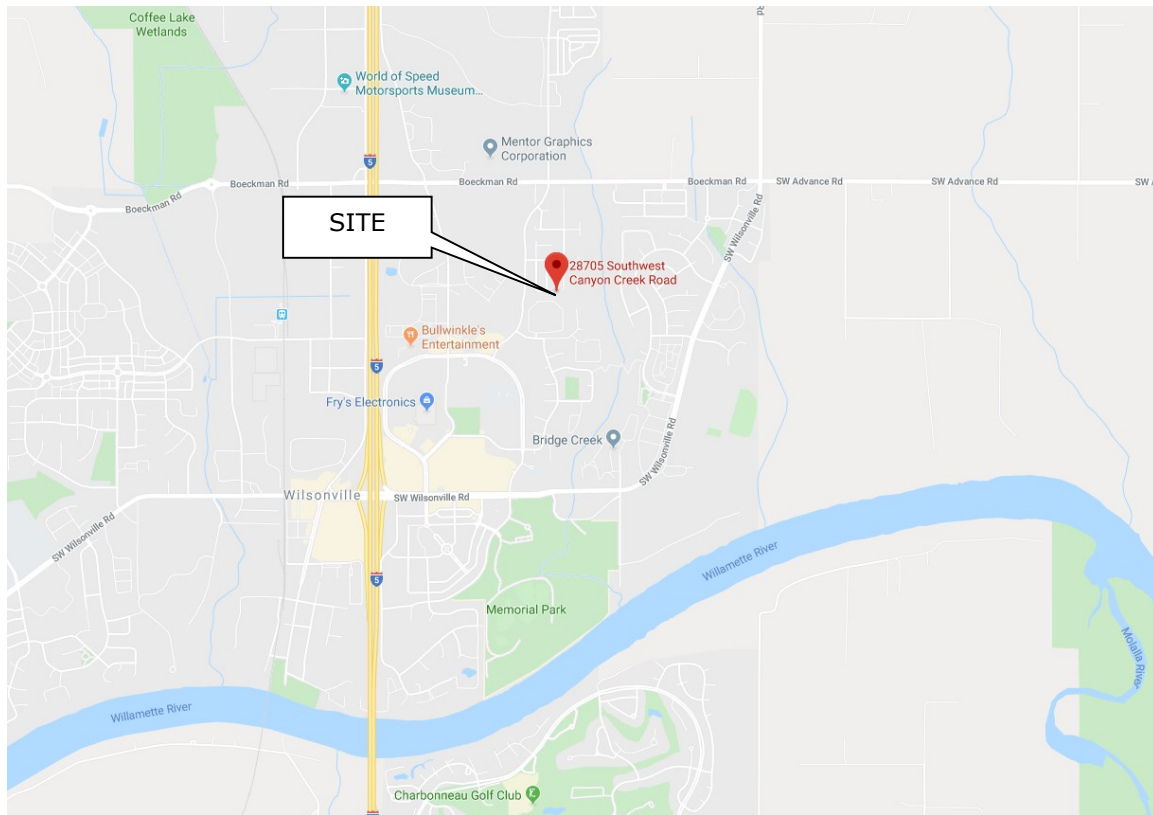

Appendix A(2)  
Soil Classification Map

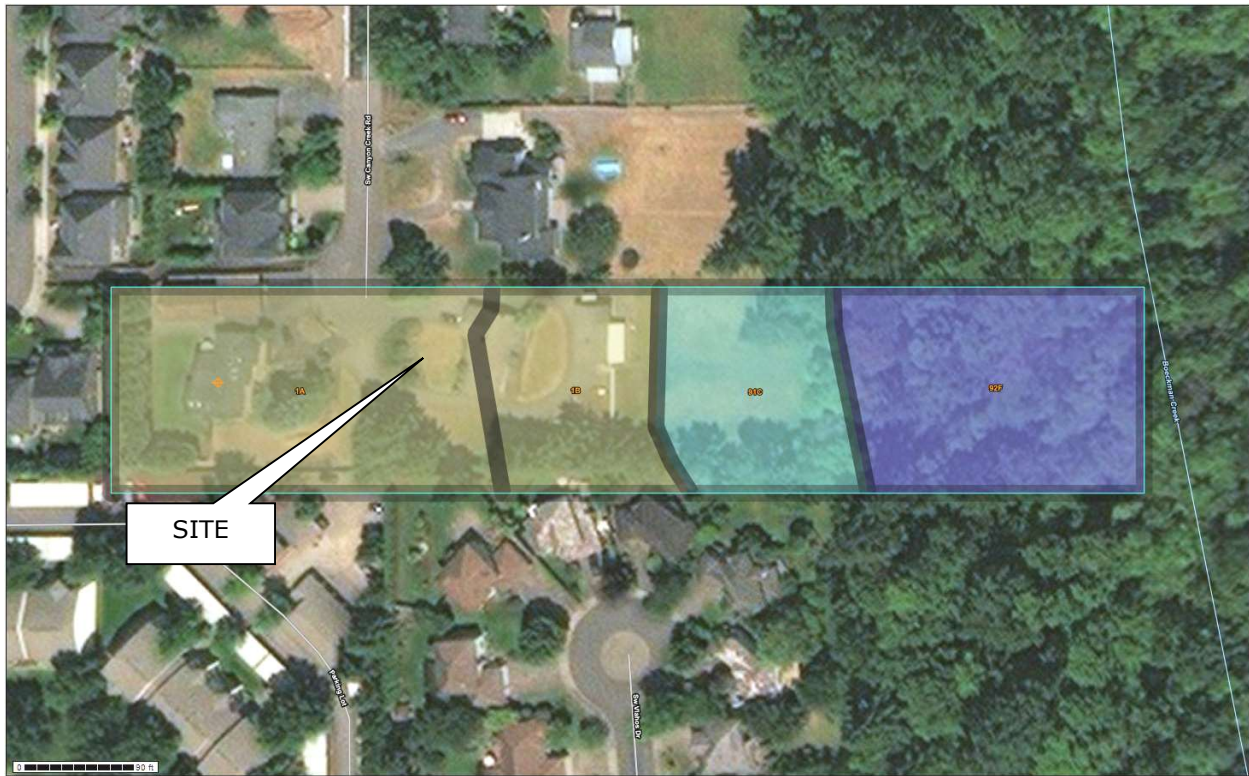

Tables — Hydrologic Soil Group — Summary By Map Unit

Summary by Map Unit — Clackamas County Area, Oregon (OR610)

Summary by Map Unit — Clackamas County Area, Oregon (OR610)

Map unit symbol	Map unit name	Rating	Acres in AOI	Percent of AOI
1A	Aloha silt loam, 0 to 3 percent slopes	C/D	1.2	36.6%
1B	Aloha silt loam, 3 to 6 percent slopes	C/D	0.6	16.8%
91C	Woodburn silt loam, 8 to 15 percent slopes	C	0.6	18.0%
92F	Xerochrepts and Haploxerolls, very steep	B	1.0	28.7%
<b>Totals for Area of Interest</b>			<b>3.3</b>	<b>100.0%</b>

<b>RUNOFF CURVE NUMBERS (TR55)</b>					
<b>Table 2-2a: Runoff curve numbers for urban areas <sup>1</sup></b>					
<b>Cover description</b>		<b>CN for hydrologic soil group</b>			
Cover type and hydrologic condition	Average percent impervious area <sup>2</sup>	A	B	C	D
<i>Fully developed urban areas (vegetation established)</i>	Use CN = 86 for Onsite and Offsite Pervious Areas				
Open space (lawns, parks, golf courses, cemeteries, etc.) <sup>3</sup> :					
Poor condition (grass cover <50%)		68	79	86	89
Fair condition (grass cover 50% to 75%)		49	69	79	84
Good condition (grass cover >75%)		39	61	74	80
<b>Impervious areas:</b>					
Paved parking lots, roofs, driveways, etc. (excluding right-of-way)		98	98	98	98
<b>Streets and roads:</b>					
Paved; curbs and storm sewers (excluding right-of-way)				98	98
Paved; open ditches (including right-of-way)				92	93
Gravel (including right-of-way)		76	85	89	91
Dirt (including right-of-way)		72	82	87	89
<b>Western desert urban areas:</b>					
Natural desert landscaping (pervious areas only) <sup>4</sup>		63	77	85	88
Artificial desert landscaping (impervious weed barrier, desert shrub with 1- to 2-inch sand or gravel mulch and basin borders)		96	96	96	96
<b>Urban districts:</b>					
Commercial and business	85	89	92	94	95
Industrial	72	81	88	91	93
<b>Residential districts by average lot size:</b>					
1/8 acre or less (town houses)	65	77	85	90	92
1/4 acre	38	61	75	83	87
1/3 acre	30	57	72	81	86
1/2 acre	25	54	70	80	85
1 acre	20	51	68	79	84
2 acres	12	46	65	77	82

Eric,

We have the field work on this project completed.

In the mean time, here is a site plan and the infiltration test results if you need to finalize your stormwater design. We had 0.4 inch/hour in HA-1 and 0.24 in/hour in HA-2, we recommend using the average of 0.3 inch/hour for design of the LIDAs or pervious pavements.

Report to follow soon.

Scott L. Hardman, P.E., G.E.  
Hardman Geotechnical Services Inc.

503-575-5634 mobile

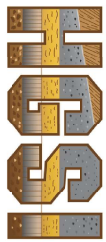

**HARDDMAN  
GEOTECHNICAL  
SERVICES INC.**

Practical, Cost-Effective Geotechnical Solutions

**SITE PLAN AND  
EXPLORATION LOCATIONS**

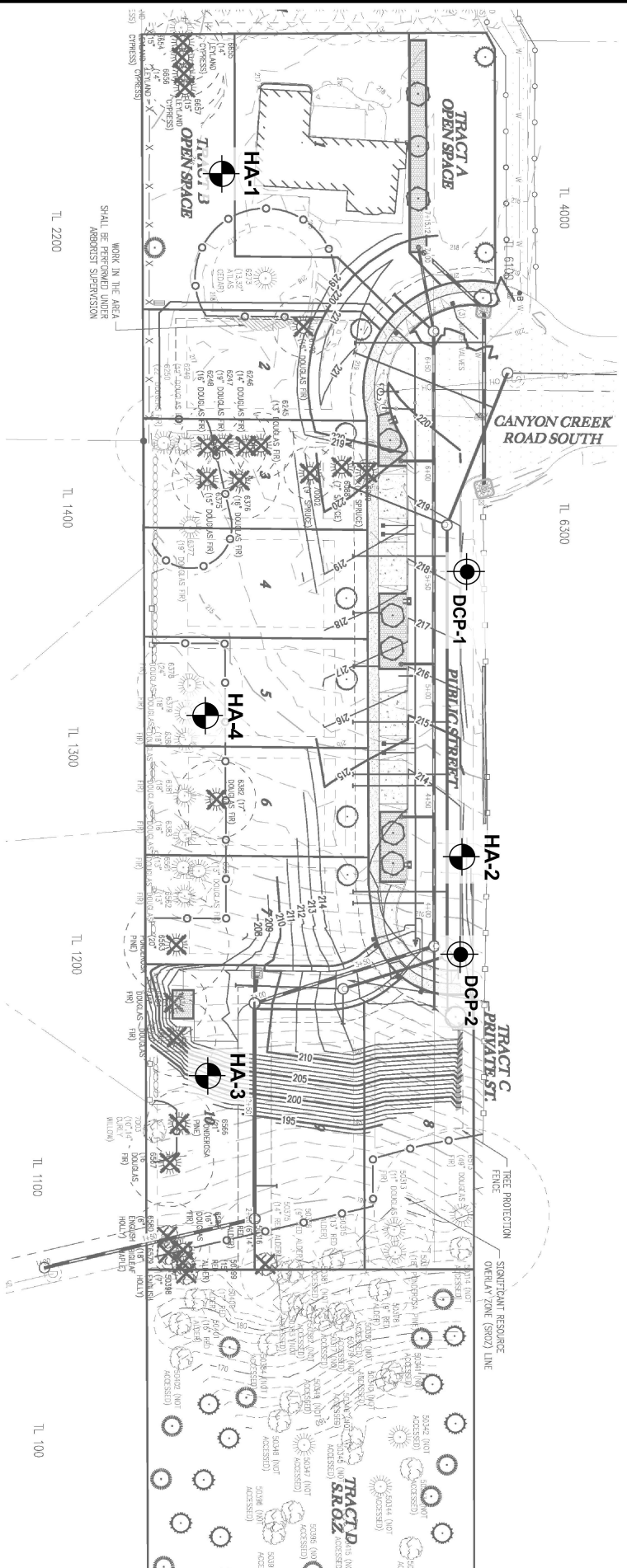

**Legend**



**HA-4** Hand Auger Designation and  
Approximate Location



**DCP-2** Dynamic Cone Penetrometer (DCP) Test,  
Approximate Location

Base map provided by Emerio Design

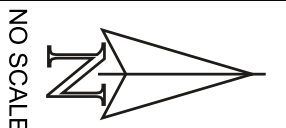

Project: 28700 and 28705 Canyon Creek Road S  
Wilsonville, Oregon

Project No. 20-2574

**FIGURE 2**



**HARDMAN  
GEOTECHNICAL  
SERVICES INC.**

Practical, Cost-Effective Geotechnical Solutions

# INFILTRATION TEST DATA

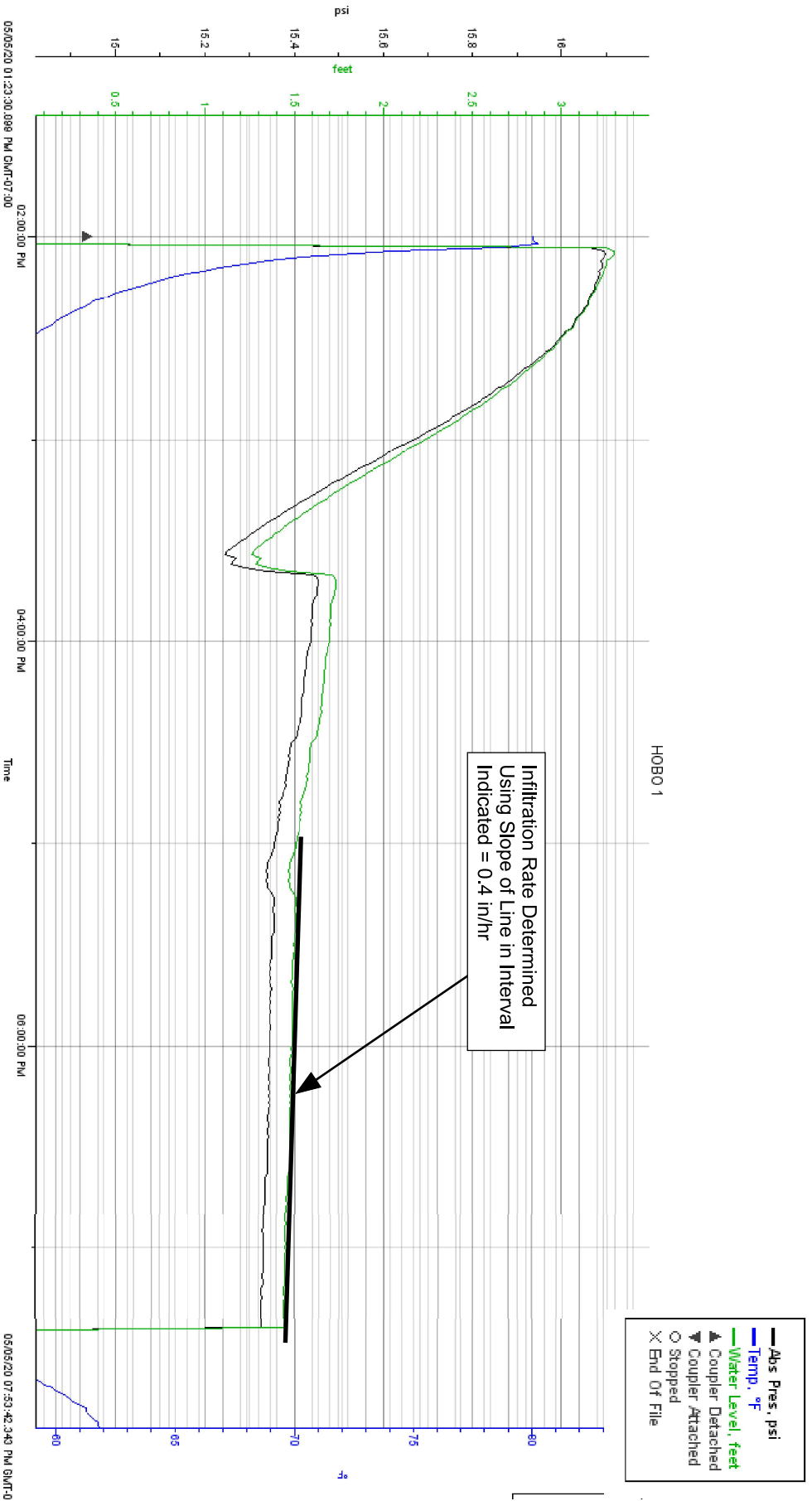

Project: 28700 and 28705 Canyon Creek Rd S  
Wilsonville, Oregon

Date Tested: 5/5/20  
Tested By: SLH  
Project No: 20-2574

Boring: HA-1  
Depth: 4 Feet





**HARDMAN  
GEOTECHNICAL  
SERVICES INC.**

Practical, Cost-Effective Geotechnical Solutions

# INFILTRATION TEST DATA

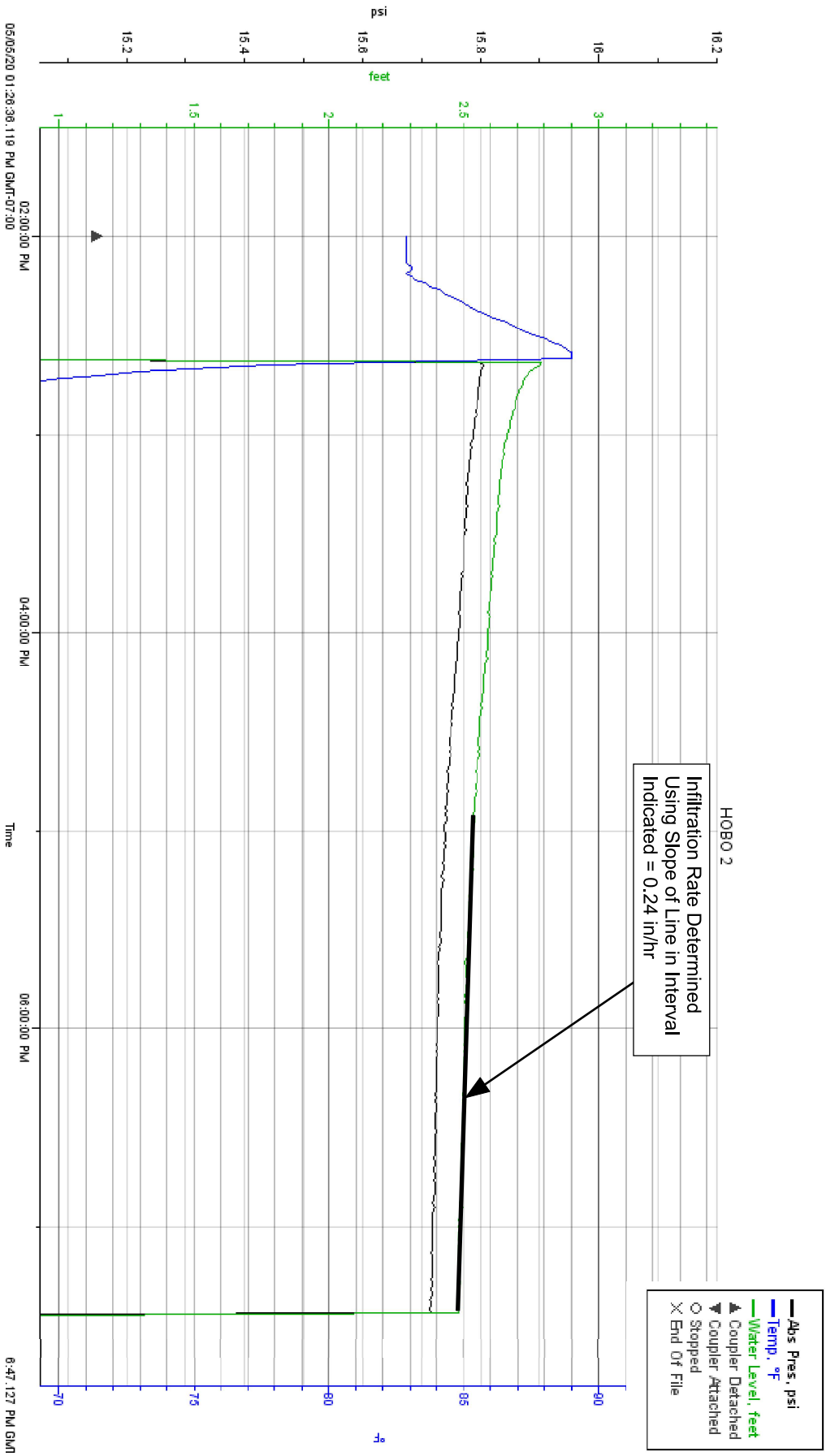

Project: 28700 and 28705 Canyon Creek Rd S  
Wilsonville, Oregon

Date Tested: 5/5/20  
Tested By: SLH  
Project No: 20-2574

Boring: HA-2  
Depth: 4 Feet

## **Appendix B**

Basin ID	Name	Total Area SF	Total Area Acres	Lot Impervious SF	ROW/Tract Imp SF	Total Impervious SF	Total Pervious SF
A	Canyon Creek S Proposed	1,629	0.04	0	1,629	1,629	0
B	Lot 5 West Roof	1,320	0.03	1,320	0	1,320	0
C	Lot 5 East Roof & Driveway	1,807	0.04	1,807	0	1,807	0
D	Canyon Creek S & Public Road West	2,930	0.07	0	2,930	2,930	0
E	Lot 4 West Roof	1,320	0.03	1,320	0	1,320	0
F	Lot 4 East Roof & Driveway	1,807	0.04	1,807	0	1,807	0
G	Public Road Center	2,507	0.06	0	2507	2,507	0
H	Lot 3 West Roof	1,320	0.03	1,320	0	1,320	0
I	Lot 3 East Roof	1,320	0.03	1,320	0	1,320	0
J	Public Road East and Lots 3 & 2 Driveways	6,815	0.16	0	6,815	6,815	0
K	Public Road Sidewalk	629	0.01	0	629	629	0
L	Lot 2 Roof	2,750	0.06	2,750	0	2,750	0
M	Lot 1 Impervious	5,815	0.13	5,815	0	5,815	0
N	Tract A Porous Pavement	174	0.00	0	174	174	0
1	Offsite 1	27,021	0.62	14,207	4,944	19,151	7,870
2	Offsite 2	22,073	0.51	2,750	2,739	5,489	16,584
3	Downstream 1	16,500	0.38	16,500	0	16,500	0
4	Downstream 2	617,646	14.18	295,241	38,482	333,723	283,923

\*Offsite Basin 1 includes impervious areas from lots T1, T2, & T3 that will route to the proposed storm system via laterals

\*\*Downstream Basin 1 only includes lot impervious areas routing to the downstream storm system via laterals

## WES BMP Sizing Report

## Project Information

Project Name	Canyon Creek South Ph 3
Project Type	Subdivision
Location	28705 SW Canyon Creek Road South
Stormwater Management Area	31931
Project Applicant	Samm-Miller LLC
Jurisdiction	OutofDistrict

## Drainage Management Area

Name	Area (sq-ft)	Pre-Project Cover	Post-Project Cover	DMA Soil Type	BMP
A	1,629	Grass	ConventionalConcrete	C	Planter 1
B	1,320	Grass	Roofs	C	Planter 1
C	1,769	Grass	ConventionalConcrete	C	Planter 2
D	2,930	Grass	Roofs	C	Planter 2
E	1,320	Grass	Roofs	C	Planter 2
F	1,807	Grass	ConventionalConcrete	C	Planter 3
G	2,507	Grass	Roofs	C	Planter 3
H	1,320	Grass	Roofs	C	Planter 3
I	1,320	Grass	ConventionalConcrete	C	Planter 4
J	6,815	Grass	ConventionalConcrete	C	Planter 4
K	629	Grass	Roofs	C	Planter 5
L	2,750	Grass	Roofs	C	Lot 2 Planter
M	5,815	Grass	Roofs	C	Lot 1 Planter

## LID Facility Sizing Details

LID ID	Design Criteria	BMP Type	Facility Soil Type	Minimum Area (sq-ft)	Planned Areas (sq-ft)	Orifice Diameter (in)
Planter 3	FlowControlAndTreatment	Stormwater Planter -	C3	225.4	278.8	0.7

		Filtration				
Planter 2	FlowControlAndTreatment	Stormwater Planter - Filtration	C3	240.8	243.0	0.7
Planter 1	FlowControlAndTreatment	Stormwater Planter - Filtration	C3	118.0	171.1	0.5
Planter 4	FlowControlAndTreatment	Stormwater Planter - Filtration	C3	325.4	279.2	0.9
Lot 1 Planter	FlowControlAndTreatment	Stormwater Planter - Filtration	Lined	407.1	408.0	0.7
Lot 2 Planter	FlowControlAndTreatment	Stormwater Planter - Filtration	Lined	192.5	193.0	0.5
Planter 5	FlowControlAndTreatment	Stormwater Planter - Filtration	C3	25.2	19.0	0.2

### Pond Sizing Details

1. FCWQT = Flow control and water quality treatment, WQT = Water quality treatment only
2. Depth is measured from the bottom of the facility and includes the three feet of media (drain rock, separation layer and growing media).
3. Maximum volume of the facility. Includes the volume occupied by the media at the bottom of the facility.
4. Maximum water storage volume of the facility. Includes water storage in the three feet of soil media assuming a 40 percent porosity.

Project: Canyon Creek South Phase 3														
Project: Conveyance Calculations														
Date: 8/15/2022														
Calc'd By: Hankins														
Pipe Information and Calculations														
Segment	Design Section	Q (Calc'd) "Q"	Pipe Dia. (inch) "D"	Pipe Dia. (ft) "D"	Manning's number "n"	Slope "S" %	Slope "S"	Area Full (Calc'd) "Af"	Wetted Perimeter (Calc'd) "Wp"	Hydraulic Radius (Calc'd) "Rf"	Velocity Full (Calc'd) "Vf"	Flow Rate Full (Calc'd) "Qf"	% Pipe Capacity Used (Calc'd) "Q/Qf"	Velocity @ Q/Qf (Calc'd) "V"
SDMH-03B to SDMH-02C	Public Street	1.394	12	1.00	0.013	0.44	0.0044	0.785	3.142	0.250	3.017	2.370	58.8%	1.77
SDMH-02C to SDMH-02B	Public Street	1.394	12	1.00	0.013	3.19	0.0319	0.785	3.142	0.250	8.124	6.381	21.8%	1.77
SDMH-02B to SDMH-01C	Tract A	1.453	12	1.00	0.013	10.87	0.1087	0.785	3.142	0.250	14.996	11.778	12.3%	1.85
SDMH-01C to SDMH-01B	Tract A	1.513	12	1.00	0.013	10.10	0.1010	0.785	3.142	0.250	14.455	11.353	13.3%	1.93
SDMH-01B to EXSDMH-00A	Tract A	1.513	12	1.00	0.013	0.44	0.0044	0.785	3.142	0.250	3.017	2.370	63.8%	1.93

														Appendix B(4)
Project:		Canyon Creek South Phase 3												
Project:		Downstream Conveyance Calculations												
Date:		8/15/2022												
Calc'd By:		Hankins												
														Pipe Information and Calculations
Segment	Design Section	Q (Calc'd) "Q"	Pipe Dia. (inch) "D"	Pipe Dia. (ft) "D"	Manning's number "n"	Slope "S" %	Slope "S"	Area Full (Calc'd) "Af"	Wetted Perimeter (Calc'd) "Wp"	Hydraulic Radius (Calc'd) "Rf"	Velocity Full (Calc'd) "Vf"	Flow Rate Full (Calc'd) "Qf"	% Pipe Capacity Used (Calc'd) "Q/Qf"	Velocity @ Q/Qf (Calc'd) "V"
EXSDMH-01 to EXSDMH-02	Downstream	1.869	12	1.00	0.013	0.40	0.0040	0.785	3.142	0.250	2.877	2.259	82.7%	2.38
EXSDMH-02 to EXSDMH-03	Downstream	1.869	12	1.00	0.013	0.40	0.0040	0.785	3.142	0.250	2.877	2.259	82.7%	2.38
EXSDMH-03 to EXSDMH-04	Downstream	1.869	12	1.00	0.013	0.40	0.0040	0.785	3.142	0.250	2.877	2.259	82.7%	2.38
EXSDMH-04 to Outfall	Downstream	11.961	12	1.00	0.013	40.80	0.4080	0.785	3.142	0.250	29.054	22.819	52.4%	15.23

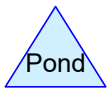
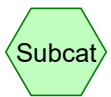
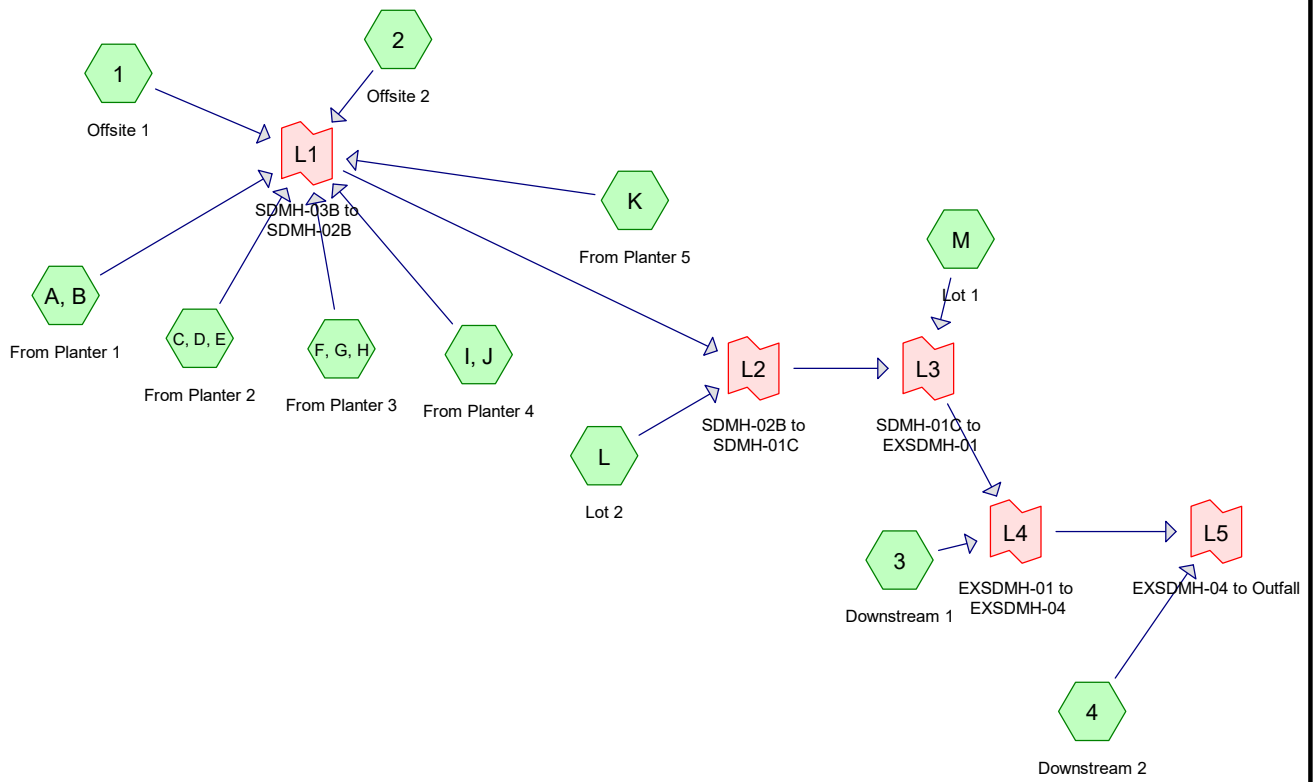

**Routing Diagram for 0463-005 Downstream**  
 Prepared by {enter your company name here}, Printed 8/15/2022  
 HydroCAD® 10.00-24 s/n 04804 © 2018 HydroCAD Software Solutions LLC



## 0463-005 Downstream

Prepared by {enter your company name here}

HydroCAD® 10.00-24 s/n 04804 © 2018 HydroCAD Software Solutions LLC

Printed 8/15/2022

Page 2

### Area Listing (all nodes)

Area (sq-ft)	CN	Description (subcatchment-numbers)
350,223	98	(3, 4)
283,923	86	(4)
53,543	98	Impervious (1, 2, A, B, C, D, E, F, G, H, I, J, K, L, M)
24,454	86	Pervious (1, 2)

**0463-005 Downstream**

Type IA 24-hr 25-year Rainfall=4.00"

Prepared by {enter your company name here}

Printed 8/15/2022

HydroCAD® 10.00-24 s/n 04804 © 2018 HydroCAD Software Solutions LLC

Page 3

**Summary for Subcatchment 1: Offsite 1**

Runoff = 0.528 cfs @ 7.89 hrs, Volume= 7,679 cf, Depth= 3.41"

Runoff by SBUH method, Split Pervious/Imperv., Time Span= 0.00-36.00 hrs, dt= 0.01 hrs  
Type IA 24-hr 25-year Rainfall=4.00"

	Area (sf)	CN	Description
*	19,151	98	Impervious
*	7,870	86	Pervious
	27,021	95	Weighted Average
	7,870	86	29.13% Pervious Area
	19,151	98	70.87% Impervious Area

Tc (min)	Length (feet)	Slope (ft/ft)	Velocity (ft/sec)	Capacity (cfs)	Description
5.0					Direct Entry,

**Subcatchment 1: Offsite 1**

Hydrograph

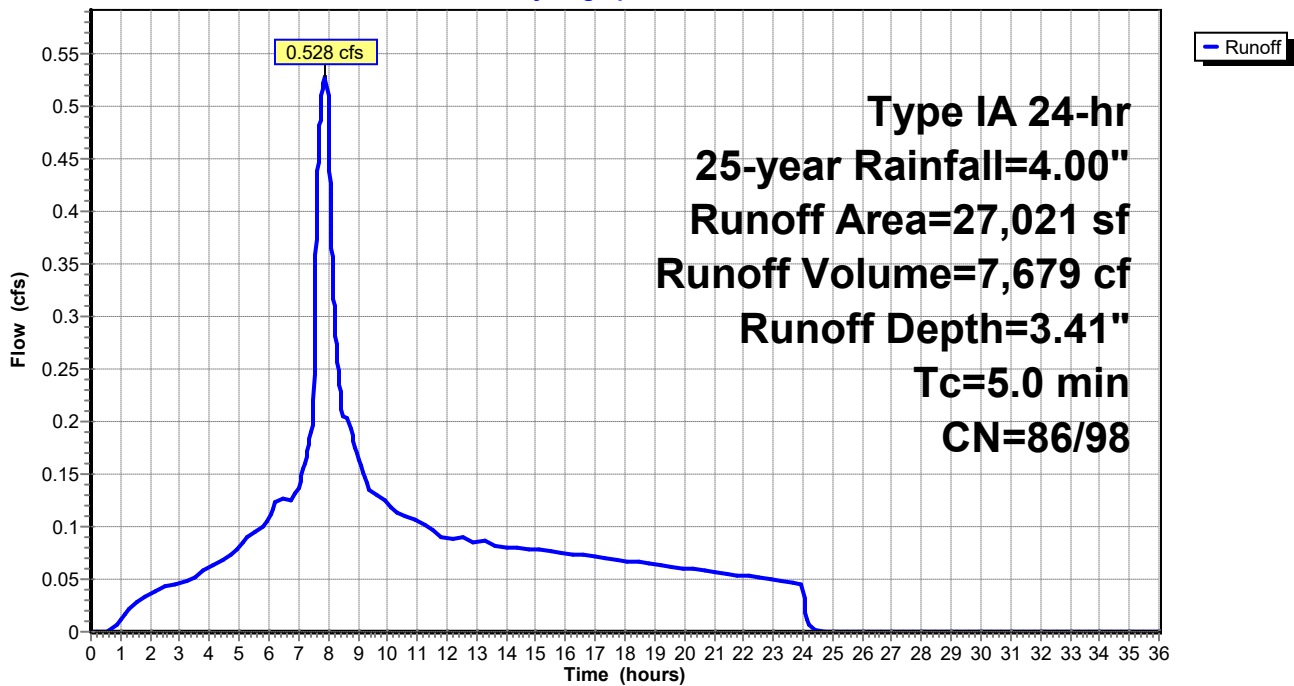

**0463-005 Downstream**

Type IA 24-hr 25-year Rainfall=4.00"

Prepared by {enter your company name here}

Printed 8/15/2022

HydroCAD® 10.00-24 s/n 04804 © 2018 HydroCAD Software Solutions LLC

Page 4

**Summary for Subcatchment 2: Offsite 2**

Runoff = 0.361 cfs @ 7.92 hrs, Volume= 5,241 cf, Depth= 2.85"

Runoff by SBUH method, Split Pervious/Imperv., Time Span= 0.00-36.00 hrs, dt= 0.01 hrs  
 Type IA 24-hr 25-year Rainfall=4.00"

	Area (sf)	CN	Description
*	5,489	98	Impervious
*	16,584	86	Pervious
	22,073	89	Weighted Average
	16,584	86	75.13% Pervious Area
	5,489	98	24.87% Impervious Area

Tc (min)	Length (feet)	Slope (ft/ft)	Velocity (ft/sec)	Capacity (cfs)	Description
5.0					Direct Entry,

**Subcatchment 2: Offsite 2**

Hydrograph

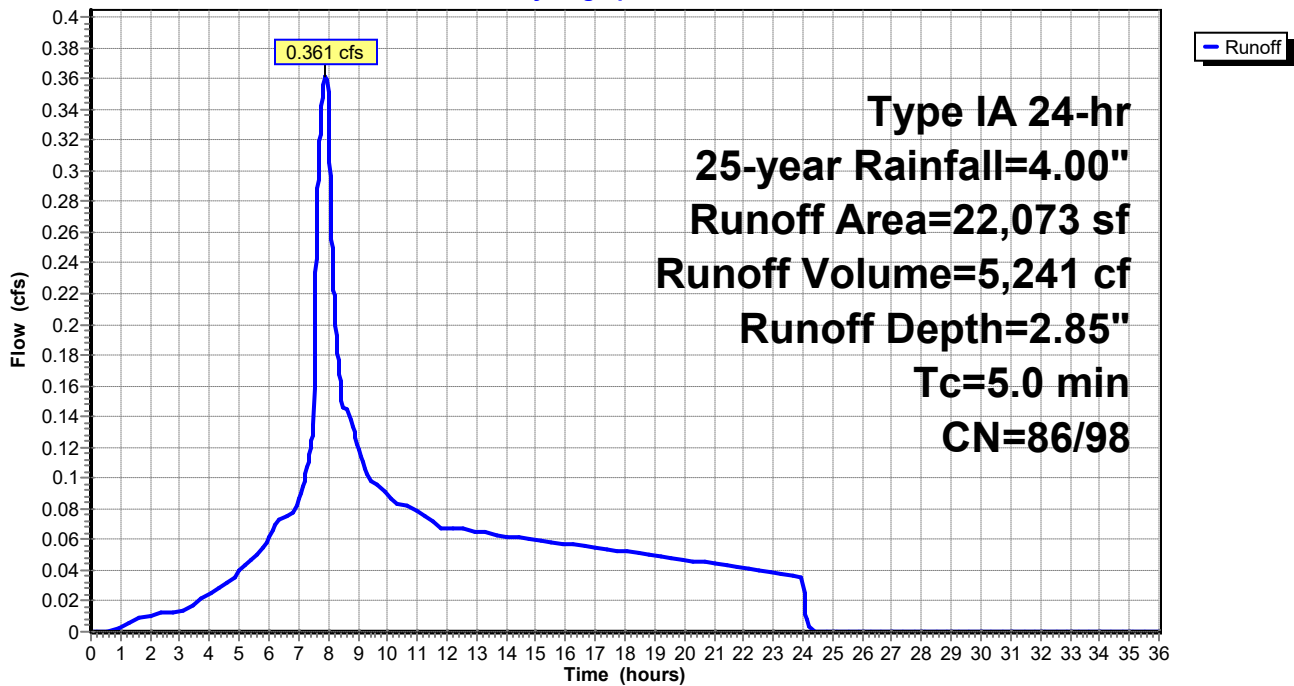

**0463-005 Downstream**

Type IA 24-hr 25-year Rainfall=4.00"

Prepared by {enter your company name here}

Printed 8/15/2022

HydroCAD® 10.00-24 s/n 04804 © 2018 HydroCAD Software Solutions LLC

Page 5

**Summary for Subcatchment 3: Downstream 1**

Runoff = 0.356 cfs @ 7.88 hrs, Volume= 5,177 cf, Depth= 3.77"

Runoff by SBUH method, Split Pervious/Imperv., Time Span= 0.00-36.00 hrs, dt= 0.01 hrs  
 Type IA 24-hr 25-year Rainfall=4.00"

	Area (sf)	CN	Description
*	16,500	98	
*	0	74	
	16,500	98	Weighted Average
	16,500	98	100.00% Impervious Area

Tc (min)	Length (feet)	Slope (ft/ft)	Velocity (ft/sec)	Capacity (cfs)	Description
5.0					Direct Entry,

**Subcatchment 3: Downstream 1**

Hydrograph

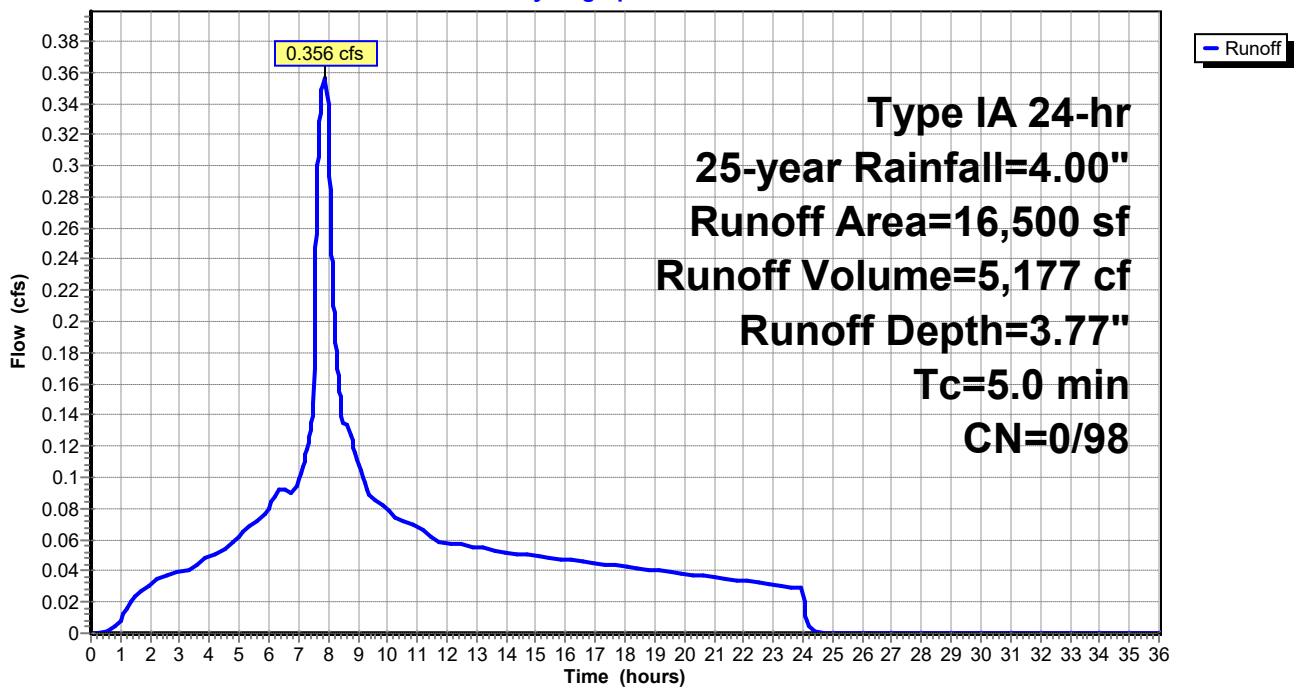

**0463-005 Downstream**

Type IA 24-hr 25-year Rainfall=4.00"

Prepared by {enter your company name here}

Printed 8/15/2022

HydroCAD® 10.00-24 s/n 04804 © 2018 HydroCAD Software Solutions LLC

Page 6

**Summary for Subcatchment 4: Downstream 2**

Runoff = 10.145 cfs @ 8.00 hrs, Volume= 164,955 cf, Depth= 3.20"

Runoff by SBUH method, Split Pervious/Imperv., Time Span= 0.00-36.00 hrs, dt= 0.01 hrs  
 Type IA 24-hr 25-year Rainfall=4.00"

	Area (sf)	CN	Description
*	333,723	98	
*	283,923	86	
	617,646	92	Weighted Average
	283,923	86	45.97% Pervious Area
	333,723	98	54.03% Impervious Area

Tc (min)	Length (feet)	Slope (ft/ft)	Velocity (ft/sec)	Capacity (cfs)	Description
5.4	50	0.0290	0.15		<b>Sheet Flow,</b> Grass: Short n= 0.150 P2= 2.60"
5.0	358	0.0290	1.19		<b>Shallow Concentrated Flow,</b> Short Grass Pasture Kv= 7.0 fps
3.7	591	0.0169	2.64		<b>Shallow Concentrated Flow,</b> Paved Kv= 20.3 fps
0.3	50	0.0060	3.11	1.697	<b>Pipe Channel,</b> 10.0" Round Area= 0.5 sf Perim= 2.6' r= 0.21' n= 0.013
0.1	84	0.0485	13.09	23.133	<b>Pipe Channel,</b> 18.0" Round Area= 1.8 sf Perim= 4.7' r= 0.38' n= 0.013
0.2	181	0.0485	13.09	23.133	<b>Pipe Channel,</b> 18.0" Round Area= 1.8 sf Perim= 4.7' r= 0.38' n= 0.013
14.7	1,314	Total			

### Subcatchment 4: Downstream 2

Hydrograph

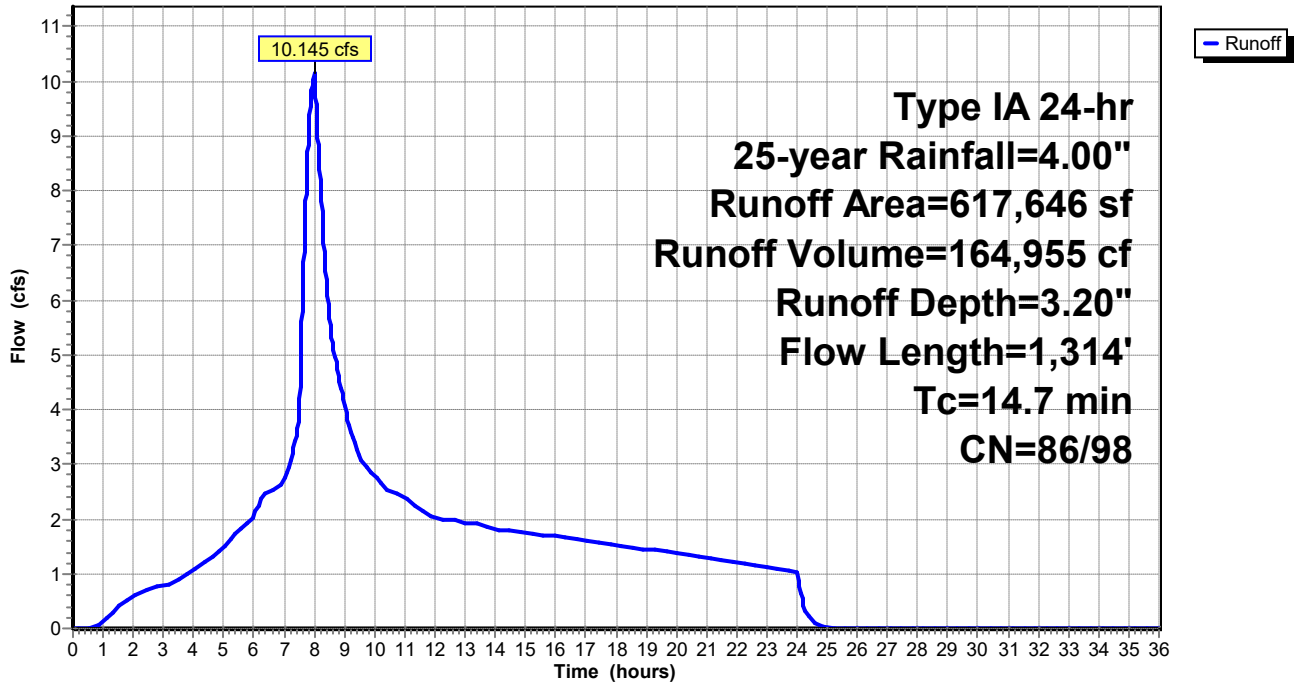

**0463-005 Downstream**

Type IA 24-hr 25-year Rainfall=4.00"

Prepared by {enter your company name here}

Printed 8/15/2022

HydroCAD® 10.00-24 s/n 04804 © 2018 HydroCAD Software Solutions LLC

Page 8

**Summary for Subcatchment A, B: From Planter 1**

Runoff = 0.064 cfs @ 7.88 hrs, Volume= 925 cf, Depth= 3.77"

Runoff by SBUH method, Split Pervious/Imperv., Time Span= 0.00-36.00 hrs, dt= 0.01 hrs  
Type IA 24-hr 25-year Rainfall=4.00"

Area (sf)	CN	Description
* 2,949	98	Impervious
2,949	98	100.00% Impervious Area

Tc (min)	Length (feet)	Slope (ft/ft)	Velocity (ft/sec)	Capacity (cfs)	Description
5.0					Direct Entry,

**Subcatchment A, B: From Planter 1**

Hydrograph

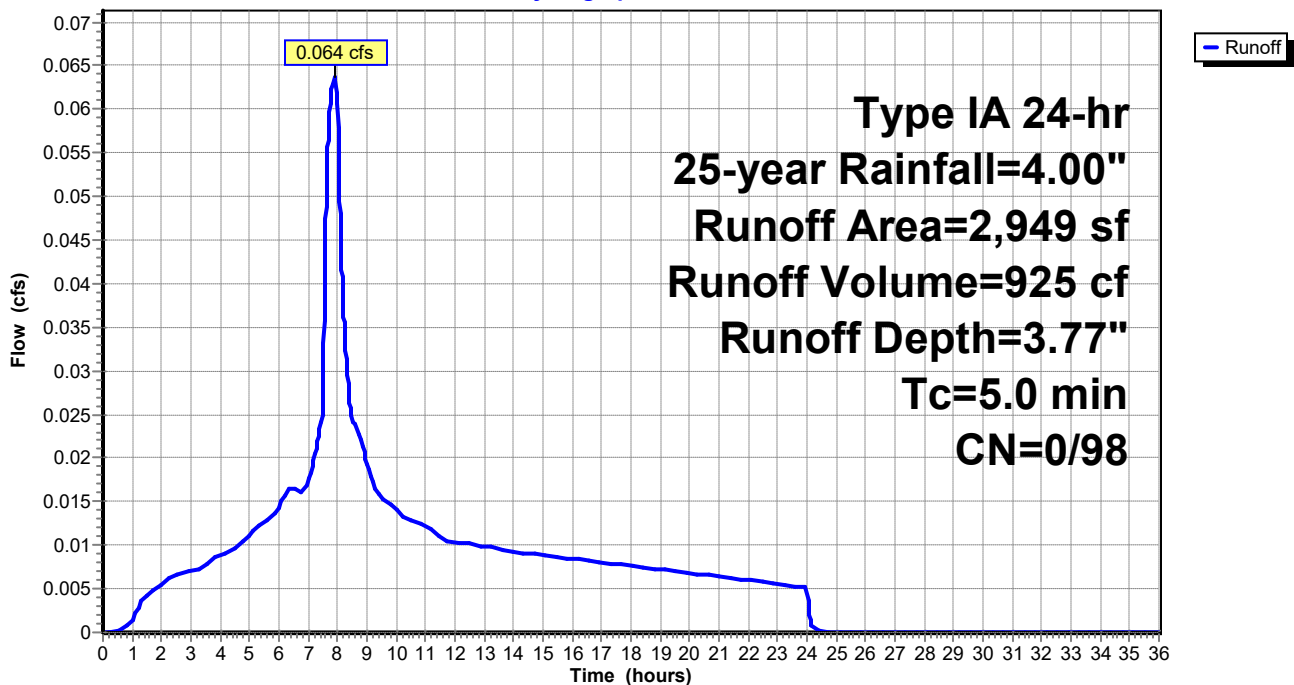

**0463-005 Downstream**

Type IA 24-hr 25-year Rainfall=4.00"

Prepared by {enter your company name here}

Printed 8/15/2022

HydroCAD® 10.00-24 s/n 04804 © 2018 HydroCAD Software Solutions LLC

Page 9

**Summary for Subcatchment C, D, E: From Planter 2**

Runoff = 0.131 cfs @ 7.88 hrs, Volume= 1,900 cf, Depth= 3.77"

Runoff by SBUH method, Split Pervious/Imperv., Time Span= 0.00-36.00 hrs, dt= 0.01 hrs  
Type IA 24-hr 25-year Rainfall=4.00"

Area (sf)	CN	Description
* 6,057	98	Impervious
6,057	98	100.00% Impervious Area

Tc (min)	Length (feet)	Slope (ft/ft)	Velocity (ft/sec)	Capacity (cfs)	Description
5.0					Direct Entry,

**Subcatchment C, D, E: From Planter 2**

Hydrograph

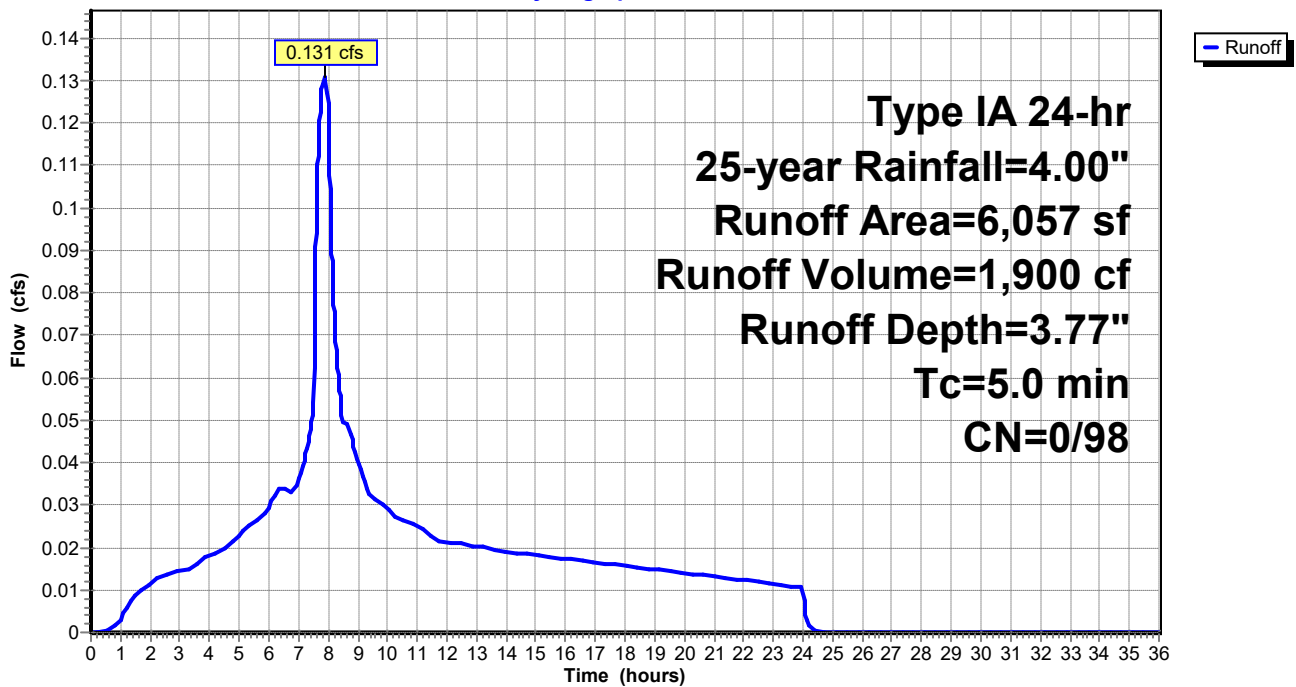



**0463-005 Downstream**

Type IA 24-hr 25-year Rainfall=4.00"

Prepared by {enter your company name here}

Printed 8/15/2022

HydroCAD® 10.00-24 s/n 04804 © 2018 HydroCAD Software Solutions LLC

Page 10

**Summary for Subcatchment F, G, H: From Planter 3**

Runoff = 0.122 cfs @ 7.88 hrs, Volume= 1,768 cf, Depth= 3.77"

Runoff by SBUH method, Split Pervious/Imperv., Time Span= 0.00-36.00 hrs, dt= 0.01 hrs  
Type IA 24-hr 25-year Rainfall=4.00"

Area (sf)	CN	Description
* 5,634	98	Impervious
5,634	98	100.00% Impervious Area

Tc (min)	Length (feet)	Slope (ft/ft)	Velocity (ft/sec)	Capacity (cfs)	Description
5.0					Direct Entry,

**Subcatchment F, G, H: From Planter 3**

Hydrograph

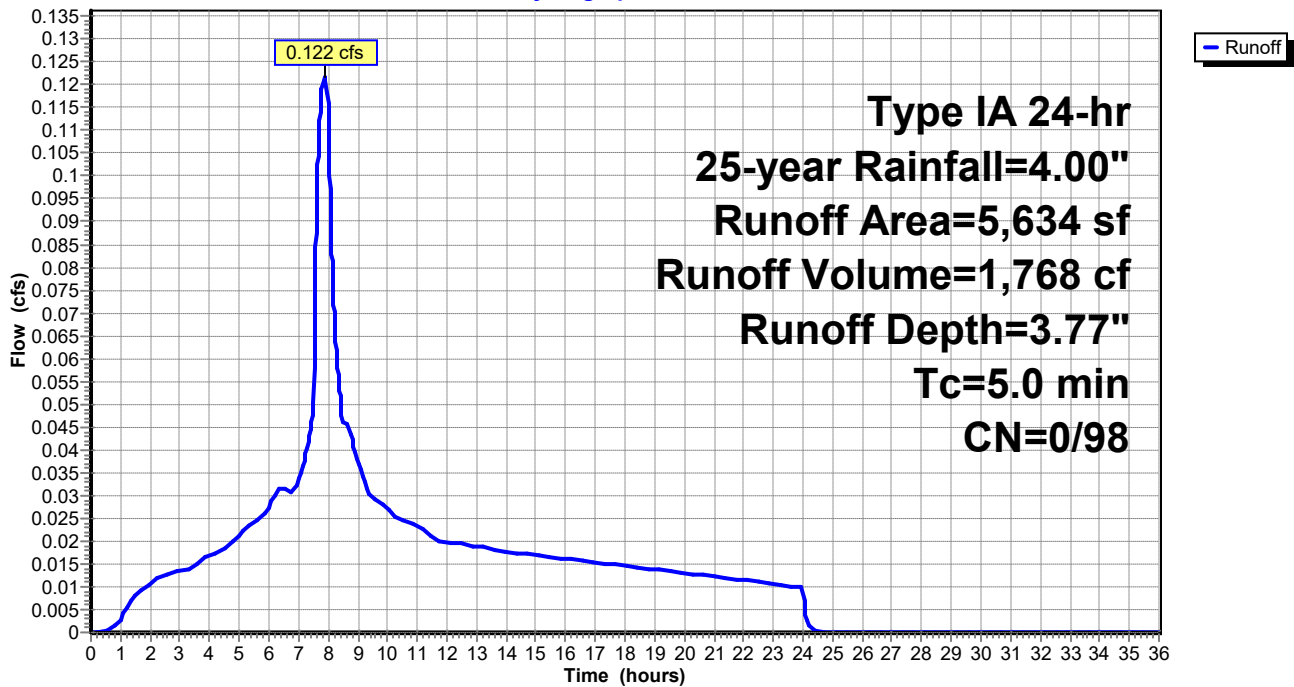

**0463-005 Downstream**

Prepared by {enter your company name here}

HydroCAD® 10.00-24 s/n 04804 © 2018 HydroCAD Software Solutions LLC

Type IA 24-hr 25-year Rainfall=4.00"

Printed 8/15/2022

Page 11

**Summary for Subcatchment I, J: From Planter 4**

Runoff = 0.176 cfs @ 7.88 hrs, Volume= 2,552 cf, Depth= 3.77"

Runoff by SBUH method, Split Pervious/Imperv., Time Span= 0.00-36.00 hrs, dt= 0.01 hrs  
Type IA 24-hr 25-year Rainfall=4.00"

Area (sf)	CN	Description
* 8,134	98	Impervious
8,134	98	100.00% Impervious Area

Tc (min)	Length (feet)	Slope (ft/ft)	Velocity (ft/sec)	Capacity (cfs)	Description
5.0					Direct Entry,

**Subcatchment I, J: From Planter 4**

Hydrograph

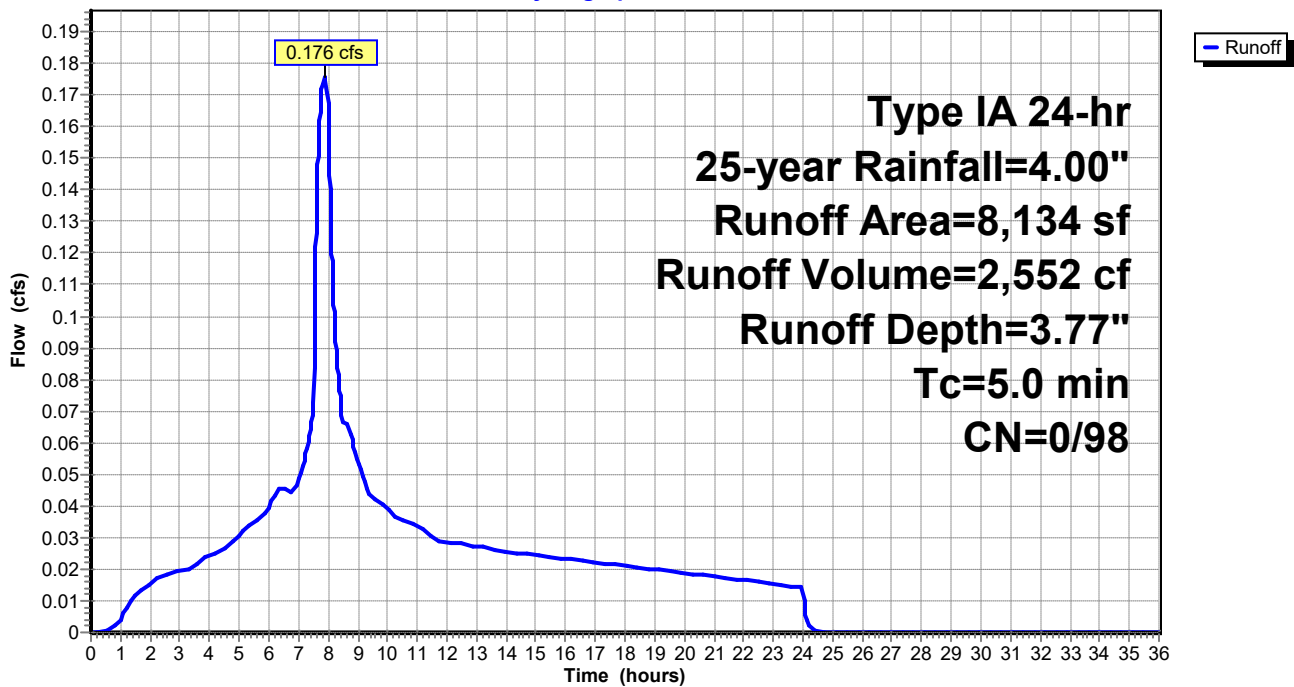

**0463-005 Downstream**

Type IA 24-hr 25-year Rainfall=4.00"

Prepared by {enter your company name here}

Printed 8/15/2022

HydroCAD® 10.00-24 s/n 04804 © 2018 HydroCAD Software Solutions LLC

Page 12

**Summary for Subcatchment K: From Planter 5**

Runoff = 0.014 cfs @ 7.88 hrs, Volume= 197 cf, Depth= 3.77"

Runoff by SBUH method, Split Pervious/Imperv., Time Span= 0.00-36.00 hrs, dt= 0.01 hrs  
 Type IA 24-hr 25-year Rainfall=4.00"

Area (sf)	CN	Description
* 629	98	Impervious
629	98	100.00% Impervious Area

Tc (min)	Length (feet)	Slope (ft/ft)	Velocity (ft/sec)	Capacity (cfs)	Description
5.0					Direct Entry,

**Subcatchment K: From Planter 5**

Hydrograph

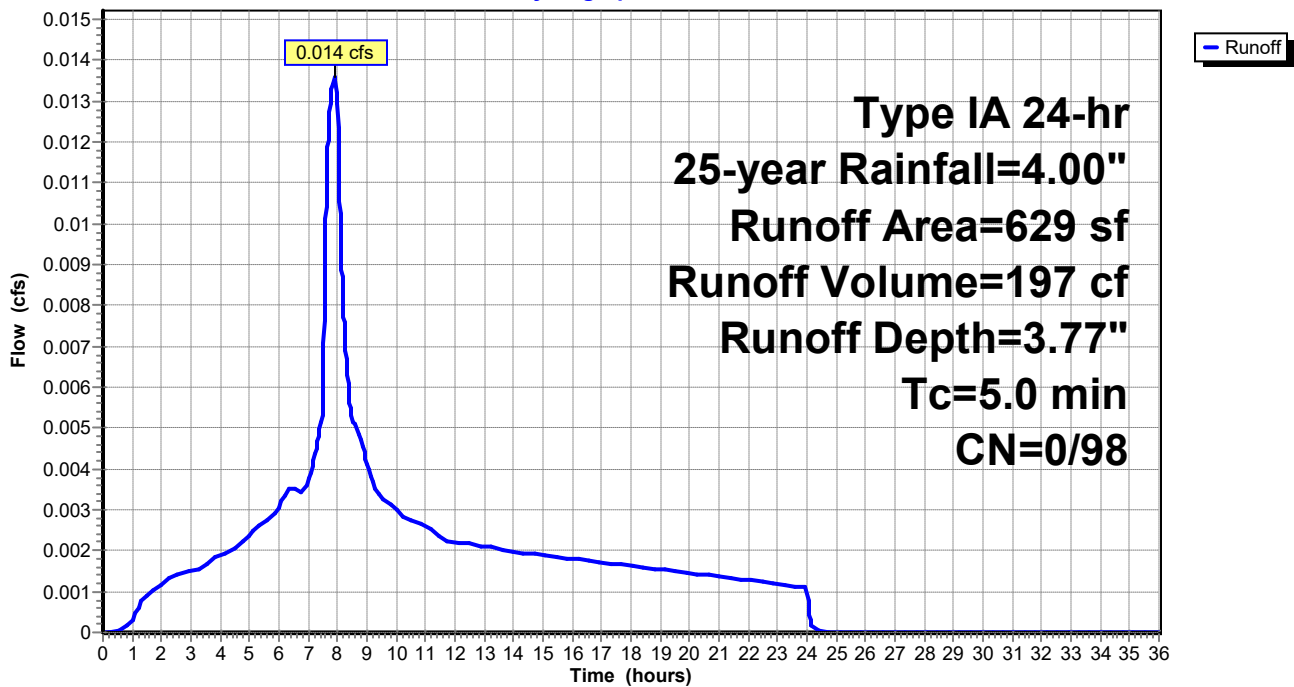

**0463-005 Downstream**

Type IA 24-hr 25-year Rainfall=4.00"

Prepared by {enter your company name here}

Printed 8/15/2022

HydroCAD® 10.00-24 s/n 04804 © 2018 HydroCAD Software Solutions LLC

Page 13

**Summary for Subcatchment L: Lot 2**

Runoff = 0.059 cfs @ 7.88 hrs, Volume= 863 cf, Depth= 3.77"

Runoff by SBUH method, Split Pervious/Imperv., Time Span= 0.00-36.00 hrs, dt= 0.01 hrs  
 Type IA 24-hr 25-year Rainfall=4.00"

Area (sf)	CN	Description
* 2,750	98	Impervious
2,750	98	100.00% Impervious Area

Tc (min)	Length (feet)	Slope (ft/ft)	Velocity (ft/sec)	Capacity (cfs)	Description
5.0					Direct Entry,

**Subcatchment L: Lot 2**

Hydrograph

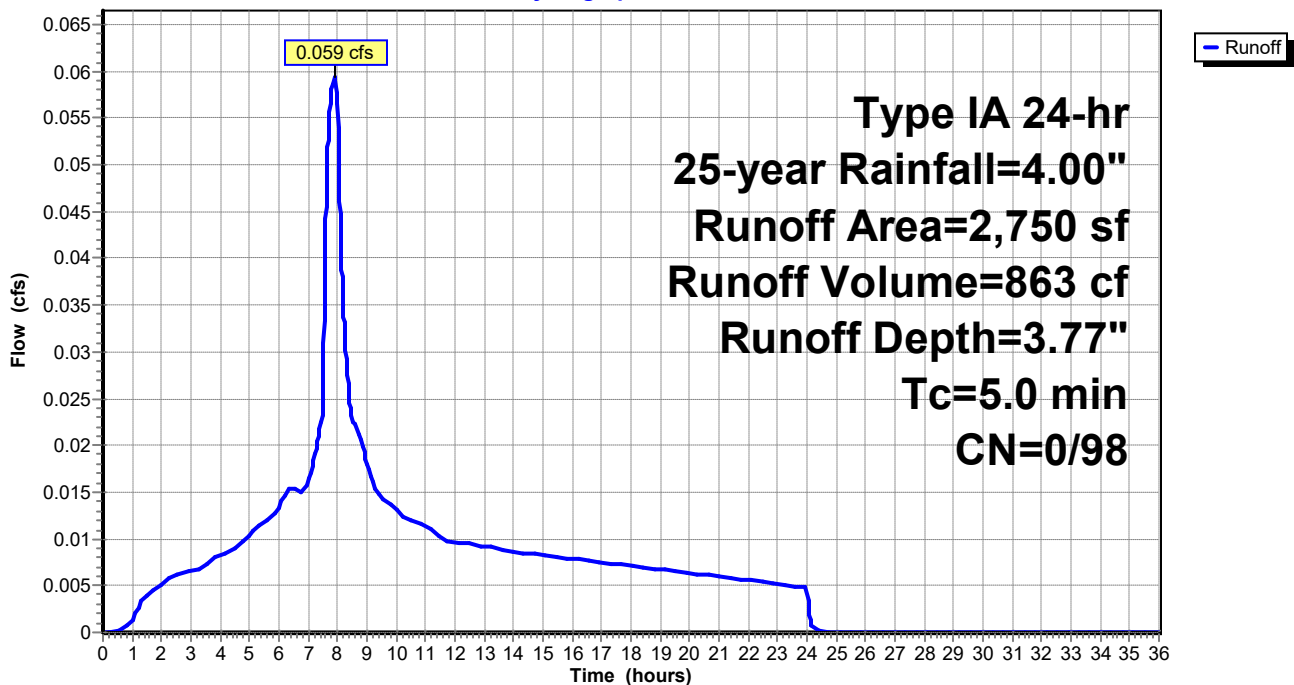

**0463-005 Downstream**

Prepared by {enter your company name here}

HydroCAD® 10.00-24 s/n 04804 © 2018 HydroCAD Software Solutions LLC

Type IA 24-hr 25-year Rainfall=4.00"

Printed 8/15/2022

Page 14

**Summary for Subcatchment M: Lot 1**

Runoff = 0.059 cfs @ 7.88 hrs, Volume= 863 cf, Depth= 3.77"

Runoff by SBUH method, Split Pervious/Imperv., Time Span= 0.00-36.00 hrs, dt= 0.01 hrs  
 Type IA 24-hr 25-year Rainfall=4.00"

Area (sf)	CN	Description
* 2,750	98	Impervious
2,750	98	100.00% Impervious Area

Tc (min)	Length (feet)	Slope (ft/ft)	Velocity (ft/sec)	Capacity (cfs)	Description
5.0					Direct Entry,

**Subcatchment M: Lot 1**

Hydrograph

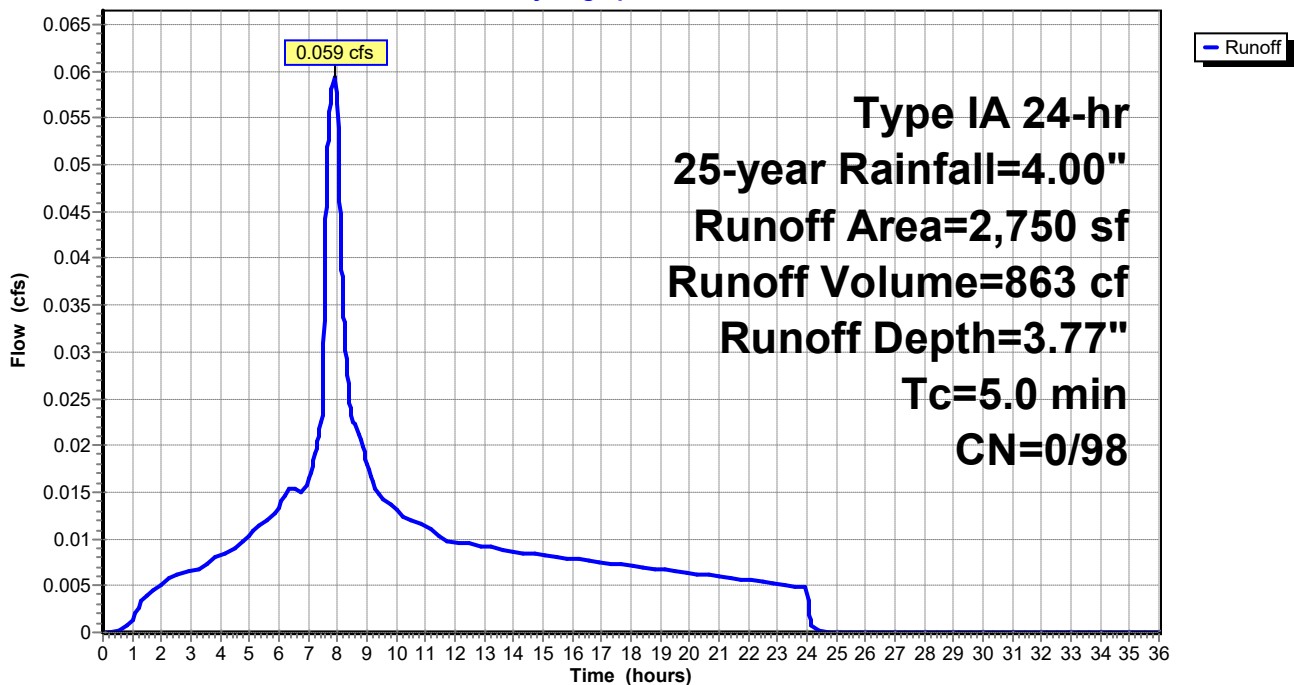

**0463-005 Downstream**

Type IA 24-hr 25-year Rainfall=4.00"

Prepared by {enter your company name here}

Printed 8/15/2022

HydroCAD® 10.00-24 s/n 04804 © 2018 HydroCAD Software Solutions LLC

Page 15

**Summary for Link L1: SDMH-03B to SDMH-02B**

Inflow Area = 72,497 sf, 66.27% Impervious, Inflow Depth = 3.35" for 25-year event  
Inflow = 1.394 cfs @ 7.89 hrs, Volume= 20,263 cf  
Primary = 1.394 cfs @ 7.89 hrs, Volume= 20,263 cf, Atten= 0%, Lag= 0.0 min

Primary outflow = Inflow, Time Span= 0.00-36.00 hrs, dt= 0.01 hrs

**Link L1: SDMH-03B to SDMH-02B**

Hydrograph

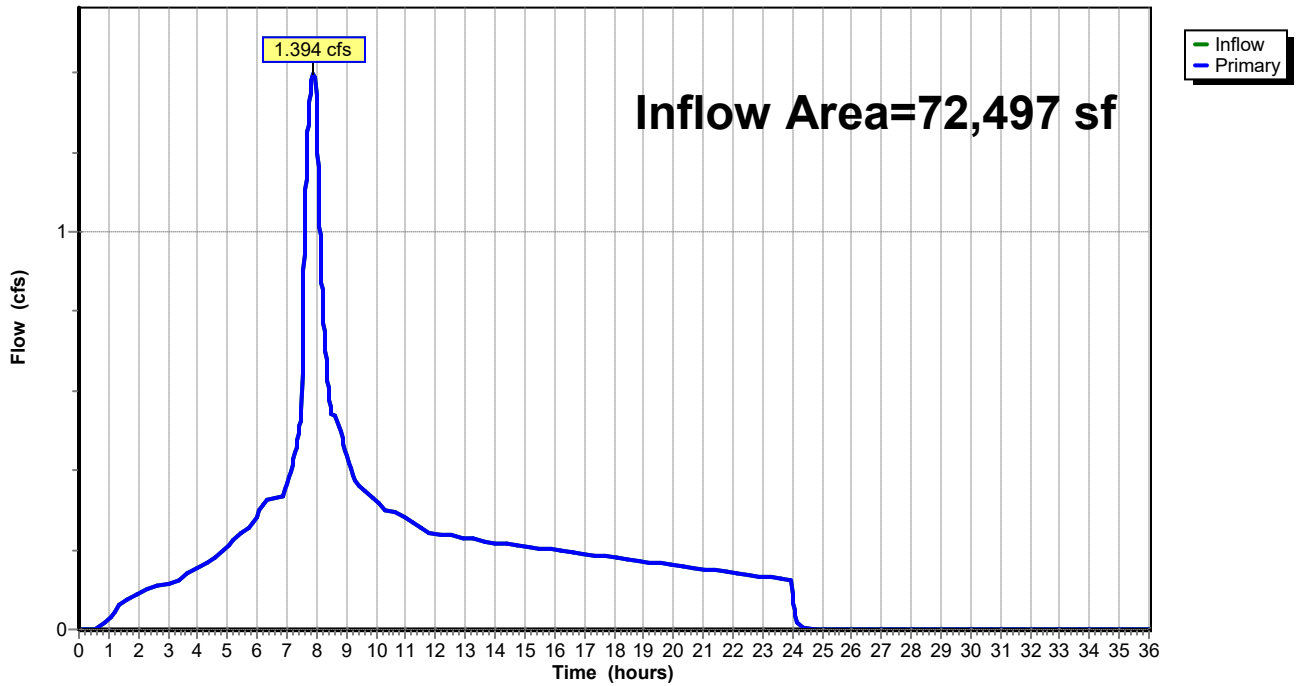

Summary for Link L2: SDMH-02B to SDMH-01C

Inflow Area = 75,247 sf, 67.50% Impervious, Inflow Depth = 3.37" for 25-year event  
Inflow = 1.453 cfs @ 7.89 hrs, Volume= 21,126 cf  
Primary = 1.453 cfs @ 7.89 hrs, Volume= 21,126 cf, Atten= 0%, Lag= 0.0 min

Primary outflow = Inflow, Time Span= 0.00-36.00 hrs, dt= 0.01 hrs

Link L2: SDMH-02B to SDMH-01C

Hydrograph

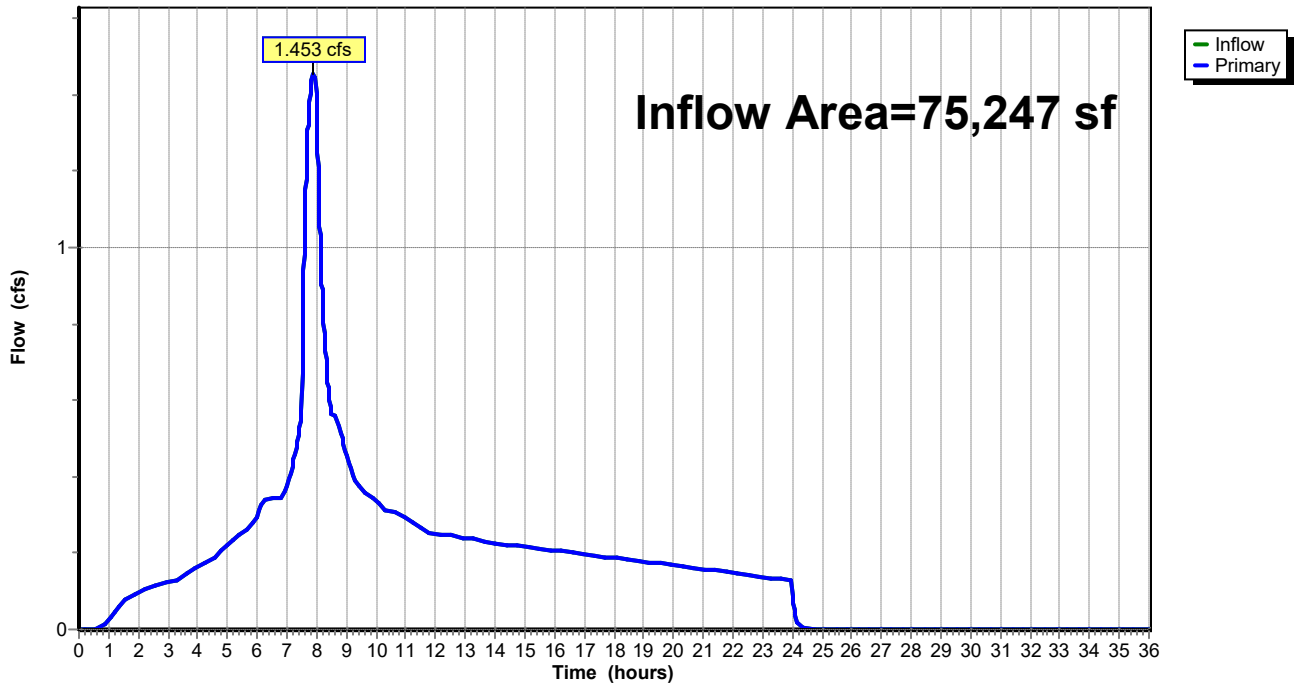

**0463-005 Downstream**

Type IA 24-hr 25-year Rainfall=4.00"

Prepared by {enter your company name here}

Printed 8/15/2022

HydroCAD® 10.00-24 s/n 04804 © 2018 HydroCAD Software Solutions LLC

Page 17

**Summary for Link L3: SDMH-01C to EXSDMH-01**

Inflow Area = 77,997 sf, 68.65% Impervious, Inflow Depth = 3.38" for 25-year event  
Inflow = 1.513 cfs @ 7.89 hrs, Volume= 21,989 cf  
Primary = 1.513 cfs @ 7.89 hrs, Volume= 21,989 cf, Atten= 0%, Lag= 0.0 min

Primary outflow = Inflow, Time Span= 0.00-36.00 hrs, dt= 0.01 hrs

**Link L3: SDMH-01C to EXSDMH-01**

Hydrograph

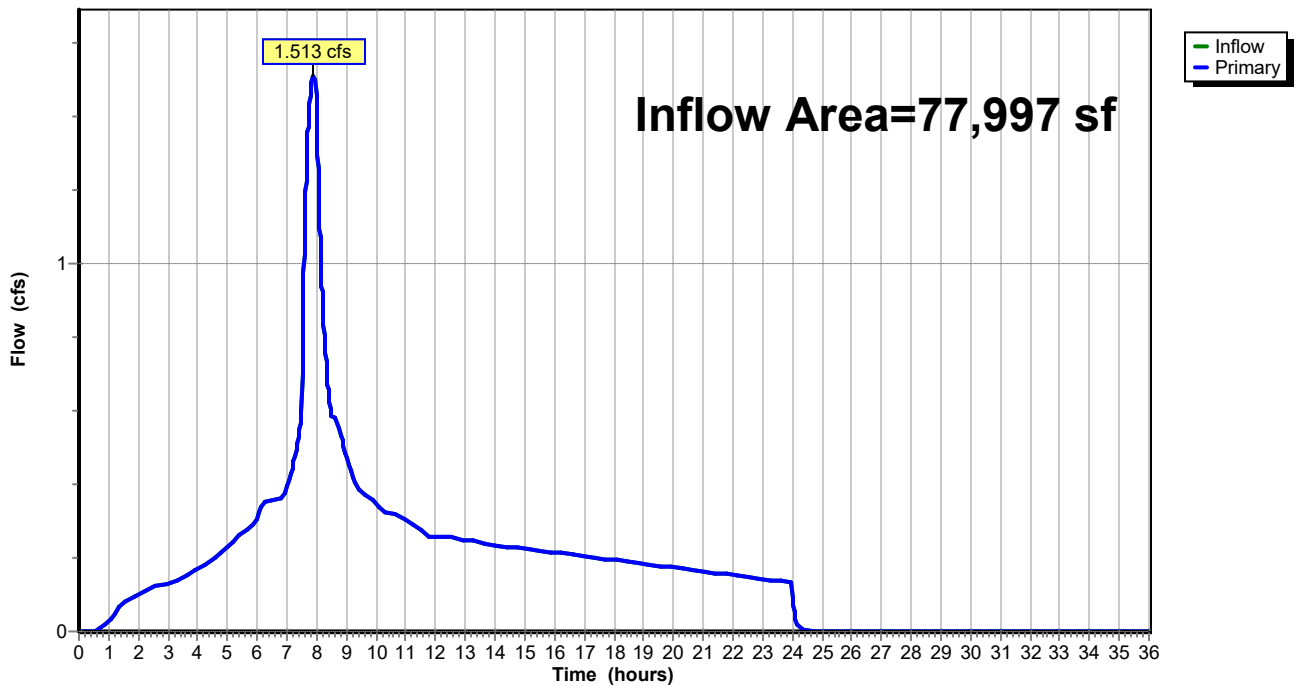



**0463-005 Downstream**

Type IA 24-hr 25-year Rainfall=4.00"

Prepared by {enter your company name here}

Printed 8/15/2022

HydroCAD® 10.00-24 s/n 04804 © 2018 HydroCAD Software Solutions LLC

Page 18

**Summary for Link L4: EXSDMH-01 to EXSDMH-04**

Inflow Area = 94,497 sf, 74.12% Impervious, Inflow Depth = 3.45" for 25-year event  
Inflow = 1.869 cfs @ 7.89 hrs, Volume= 27,166 cf  
Primary = 1.869 cfs @ 7.89 hrs, Volume= 27,166 cf, Atten= 0%, Lag= 0.0 min

Primary outflow = Inflow, Time Span= 0.00-36.00 hrs, dt= 0.01 hrs

**Link L4: EXSDMH-01 to EXSDMH-04**

Hydrograph

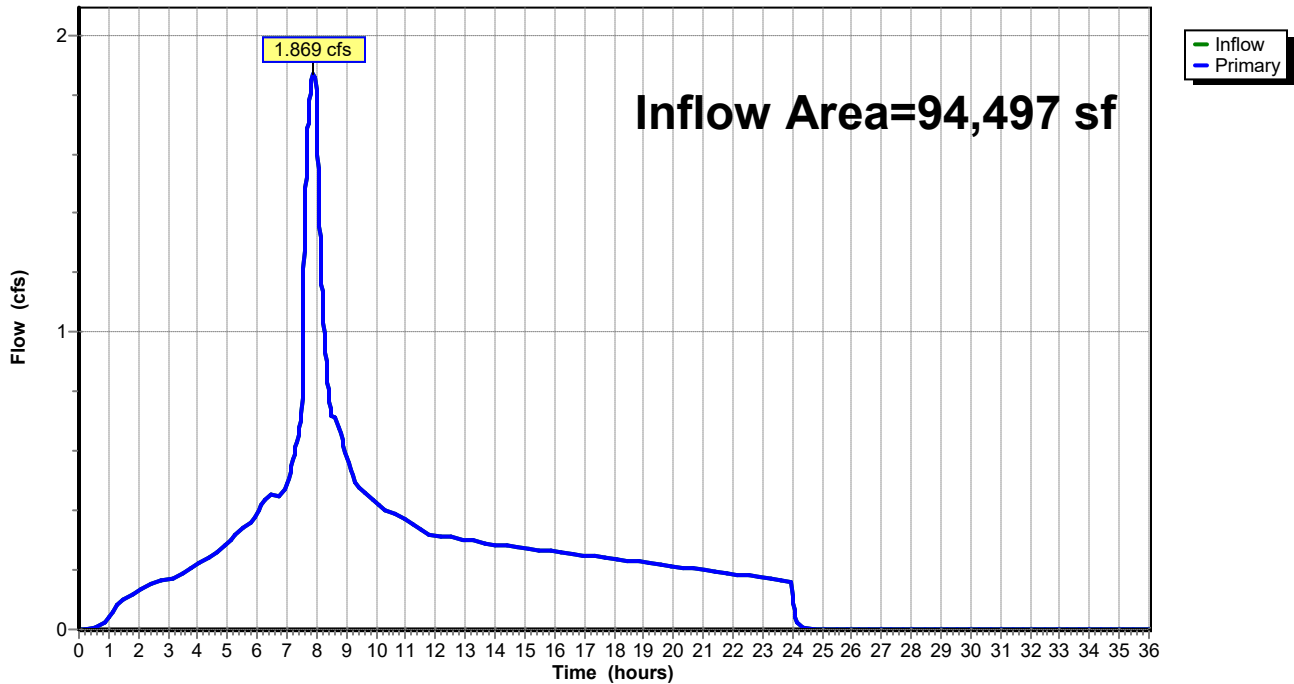

### Summary for Link L5: EXSDMH-04 to Outfall

Inflow Area = 712,143 sf, 56.70% Impervious, Inflow Depth = 3.24" for 25-year event  
Inflow = 11.961 cfs @ 8.00 hrs, Volume= 192,120 cf  
Primary = 11.961 cfs @ 8.00 hrs, Volume= 192,120 cf, Atten= 0%, Lag= 0.0 min

Primary outflow = Inflow, Time Span= 0.00-36.00 hrs, dt= 0.01 hrs

### Link L5: EXSDMH-04 to Outfall

Hydrograph

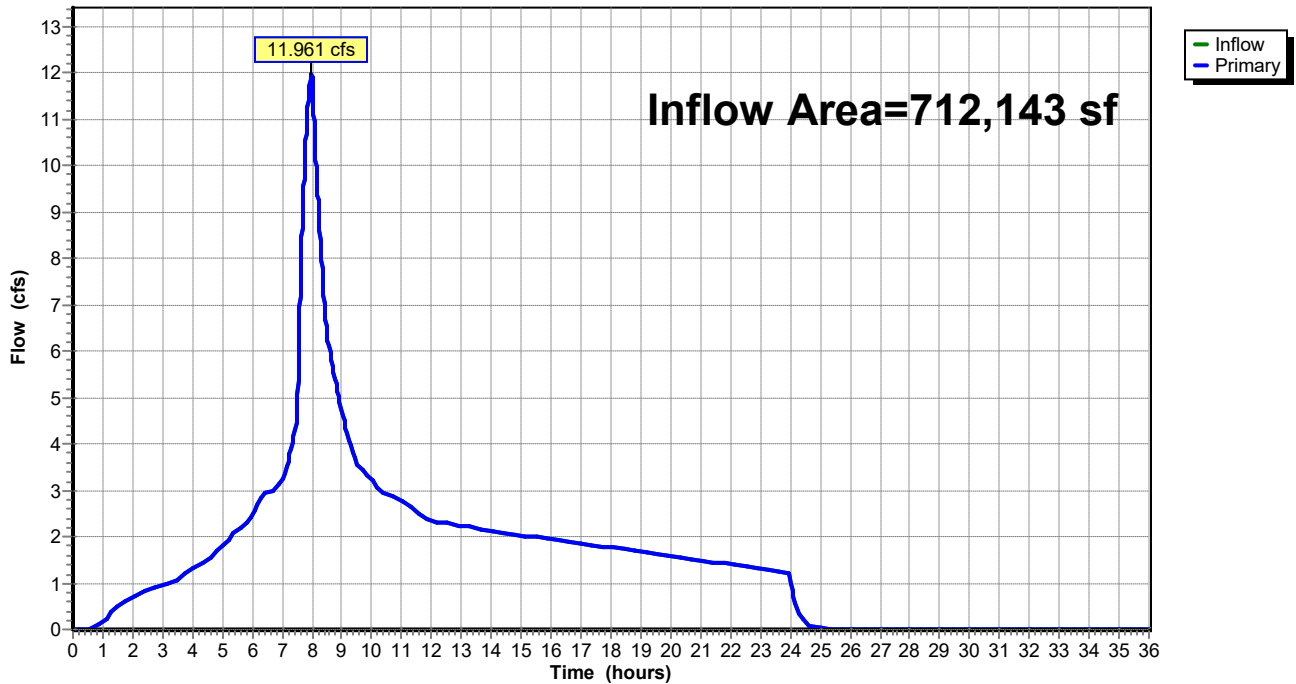

## **Appendix C**

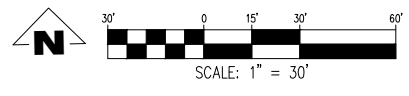

28700 CANYON CREEK RD S  
 TAX LOT 6400  
 TAX MAP 31W13BD  
 NW 1/4 OF SEC.13, T.3S R.1W W.M.  
 WILSONVILLE, OREGON

**APPENDIX C(1)  
 PRE-DEVELOPED SITE MAP**

REVISIONS	
NO.	DATE
0	07/07/21
1	09/07/21
2	12/16/21
3	03/30/22
4	05/02/22
5	05/04/22
6	08/12/22

**EMERIO**  
 ENGINEERING - SURVEYING - DESIGN  
 6446 SW FALLBROOK PLACE SUITE 100  
 BEAVERTON OREGON 97008  
 TEL: (503) 748-8812  
 FAX: (503) 639-8592  
 www.emeriodesign.com

FILE:P:\0463-005 Canyon Creek So Phase 3\0463-005 Basin Areas Pre Layout\Basin Areas Plot Date: 8/15/2022 2:57 PM, by: Josh Meyer

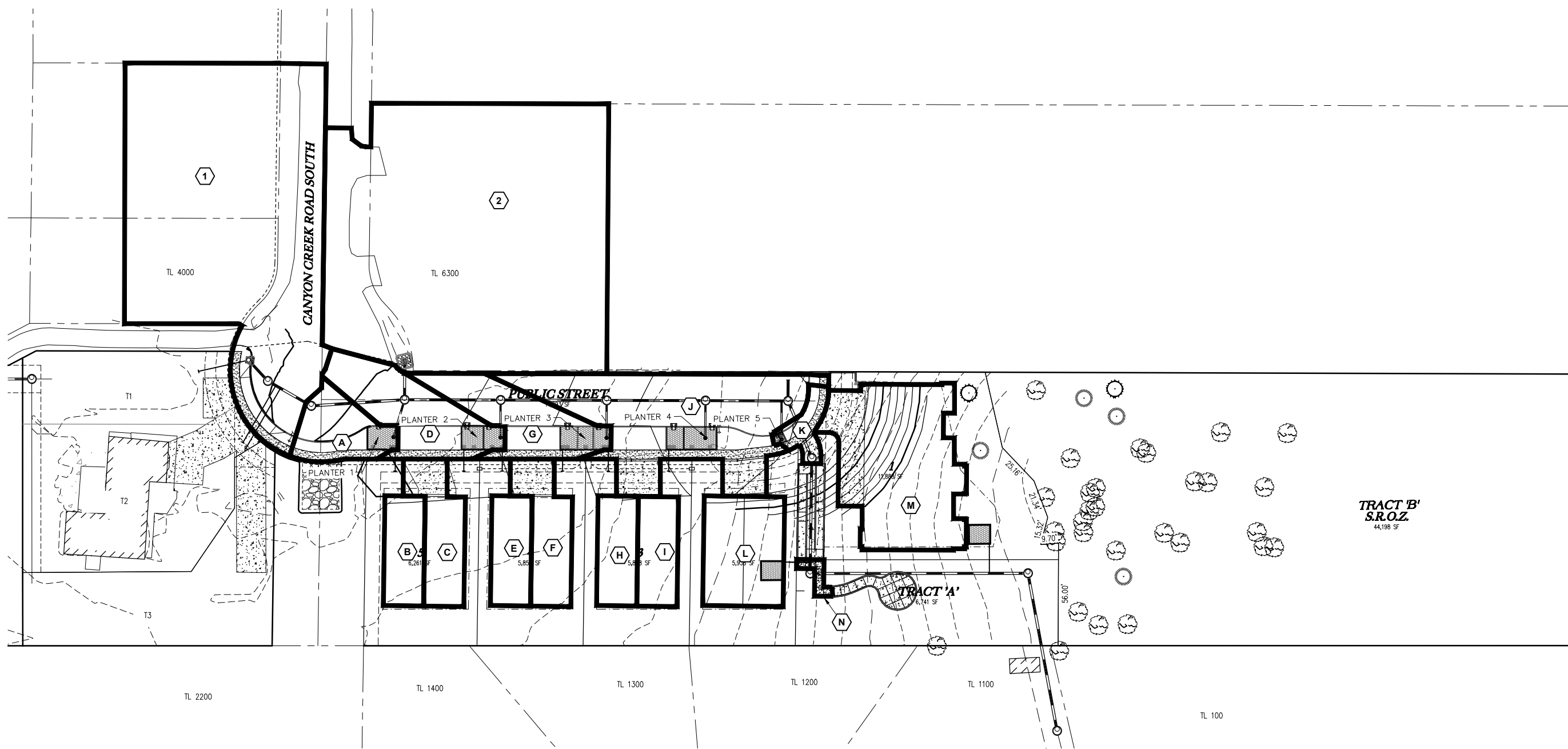

28700 CANYON CREEK RD S  
 TAX LOT 6400  
 TAX MAP 31W13BD  
 NW 1/4 OF SEC.13, T.3S R.1W W.M.  
 WILSONVILLE, OREGON

**APPENDIX C(2)  
 POST-DEVELOPED BASIN  
 MAP**

NO.	DATE	DESCRIPTION
1	12/16/21	1ST REVISION
2	03/30/22	2ND REVISION
3	05/02/22	3RD REVISION
4	05/02/22	4TH REVISION
5	05/04/22	5TH REVISION
6	09/12/22	6TH REVISION
7	11/01/22	ADDRESS CITY REVIEW COMMENTS
8	01/05/23	ADDRESS CITY REVIEW COMMENTS
9	07/26/23	STREET LIGHT REVISION

**EMERIO**  
 ENGINEERING - SURVEYING - DESIGN  
 6446 SW FALLBROOK BLVD, SUITE 100  
 BEAVERTON, OREGON 97008  
 TEL: (503) 748-8812  
 FAX: (503) 639-8992  
 www.emeriodesign.com

FILE: P:\0463-005 Canyon Creek So Phase 3\0463-005 Storm\CAD\0463-005 Conveyance Basins\_Layout\_Basin Areas\_Plot Date: 9/28/2023 2:30 PM, by: Josh Meyer

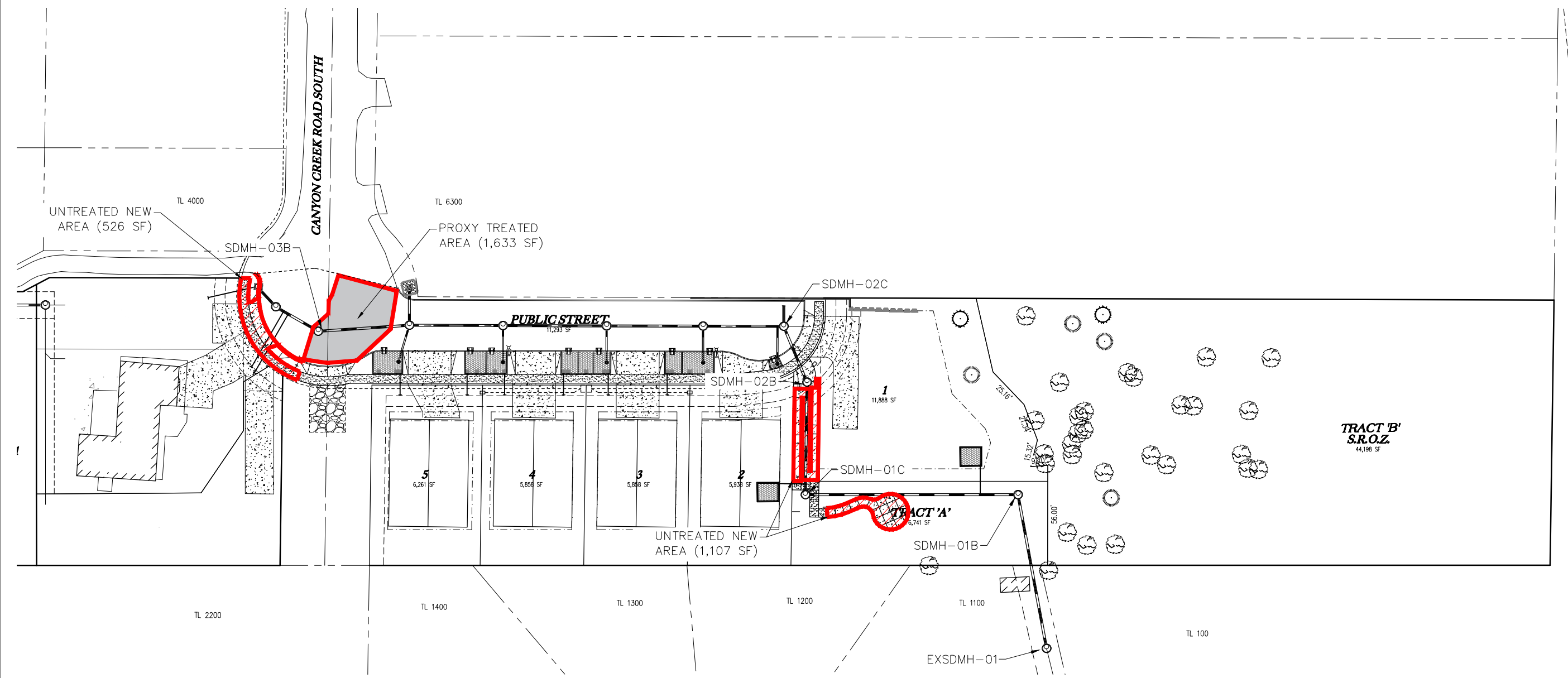
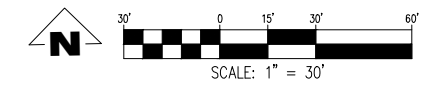

28700 CANYON CREEK RD S  
 TAX LOT 6400  
 TAX MAP 31W13BD  
 NW 1/4 OF SEC.13, T.3S R.1W W.M.  
 WILSONVILLE, OREGON

**APPENDIX C(3)  
 PROXY TREATMENT AREA  
 & STORM SYSTEM MAP**

REVISIONS

NO.	DATE	DESCRIPTION
1	12/16/21	1ST REVISION
2	12/16/21	2ND REVISION
3	03/30/22	3RD REVISION
4	05/02/22	4TH REVISION
5	05/04/22	5TH REVISION
6	09/12/22	6TH REVISION
7	11/01/22	ADDRESS CITY REVIEW COMMENTS
8	01/05/23	ADDRESS CITY REVIEW COMMENTS
9	07/26/23	STREET LIGHT REVISION

**EMERIO**  
 ENGINEERING - SURVEYING - DESIGN

6446 SW FALLBROOK PLACE SUITE 100  
 BEAVERTON OREGON 97008  
 TEL: (503) 748-8812  
 FAX: (503) 639-8592  
 www.emeriodesign.com

FILE:P:\0463-005 Canyon Creek So Phase 3\0463-005 Basin Areas Post Layout\Proxy Areas Plot Date: 9/28/2023 2:31 PM by: Josh Meyer

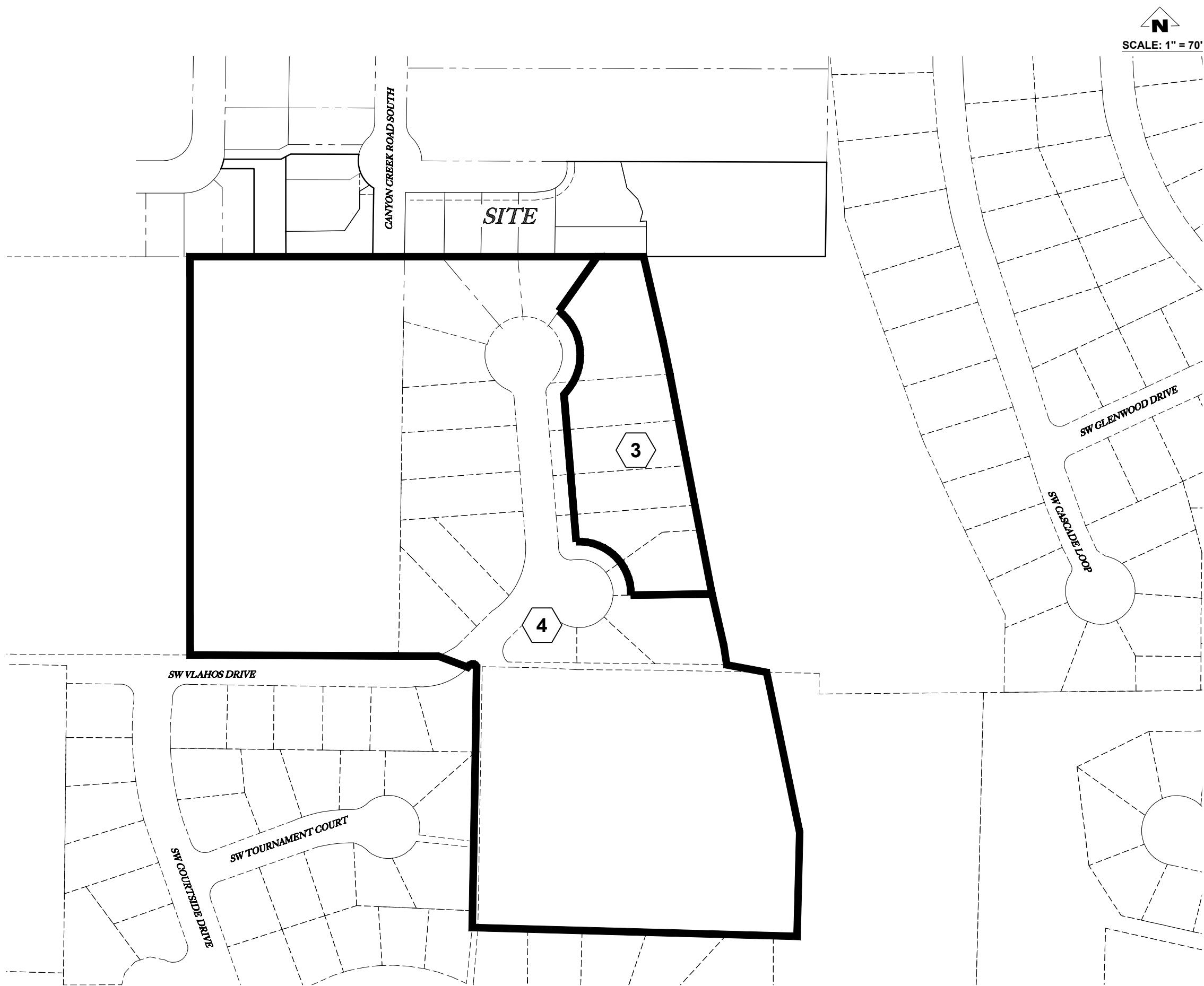

28700 CANYON CREEK RD S  
 TAX LOT 6400  
 TAX MAP 31W13BD  
 NW 1/4 OF SEC.13, T.3S R.1W W.M.  
 WILSONVILLE, OREGON

**APPENDIX C(4)  
 DOWNSTREAM BASIN MAP**

REVISIONS	
NO.	DESCRIPTION
1	12/16/21
2	03/30/22
3	05/02/22
4	05/04/22
5	09/12/22
6	11/01/22
7	01/05/23
8	07/26/23
9	

**EMERIO**  
 ENGINEERING • SURVEYING • DESIGN  
 6446 SW FALLBROOK PLACE SUITE 100  
 BEAVERTON OREGON 97008  
 TEL: (503) 748-8812  
 FAX: (503) 639-8592  
 www.emeriodesign.com

FILE:P:\0463-005 Canyon Creek So Phase 3\docs\csm\Storm\CA\0463-005 Downstream Basins Layout - Basin Areas Plot Date: 9/28/2023 2:17 PM, by: Josh Meyer

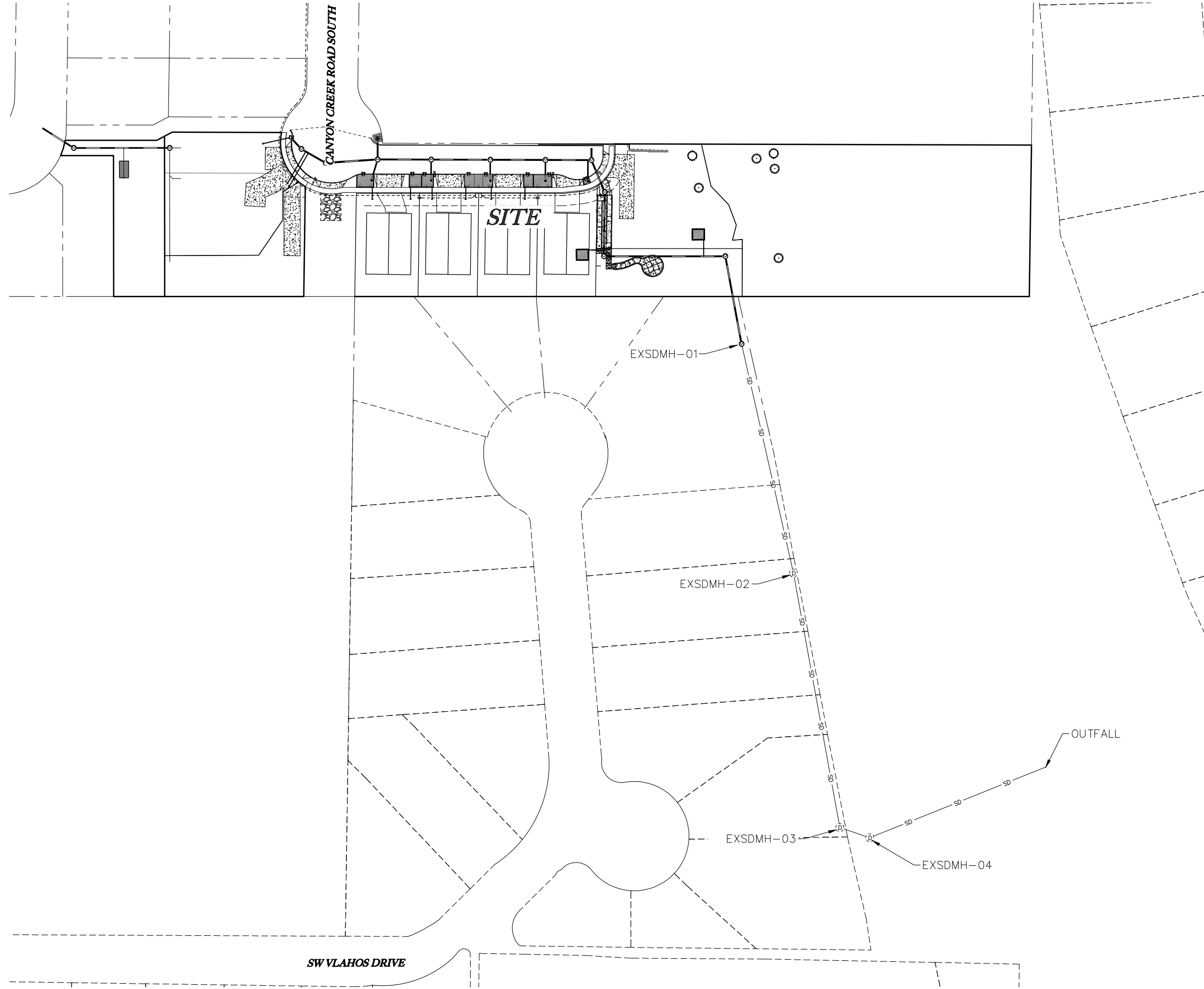

28700 CANYON CREEK RD S  
 TAX LOT 6400  
 TAX MAP 31W13BD  
 NW 1/4 OF SEC.13, T.3S R.1W W.M.  
 WILSONVILLE, OREGON

**APPENDIX C(5)  
 DOWNSTREAM SYSTEM  
 MAP**

REVISIONS	
NO.	DESCRIPTION
1	12/16/21
2	2ND REVISION
3	03/30/22
4	05/02/22
5	05/04/22
6	09/12/22
7	11/01/22
8	01/05/23
9	07/26/23

**EMERIO**  
 ENGINEERING • SURVEYING • DESIGN  
 6446 SW FALLBROOK PLACE SUITE 100  
 BEAVERTON OREGON 97008  
 TEL: (503) 748-8812  
 FAX: (503) 639-8592  
 www.emeriodesign.com

FILE:P:\0463-005 Canyon Creek So Phase 3\0463-005 Downstream System Layout Basin Areas Plot Date: 9/29/2023 2:22 PM by: Josh Meyer



# Exhibit F

**Exhibit F**

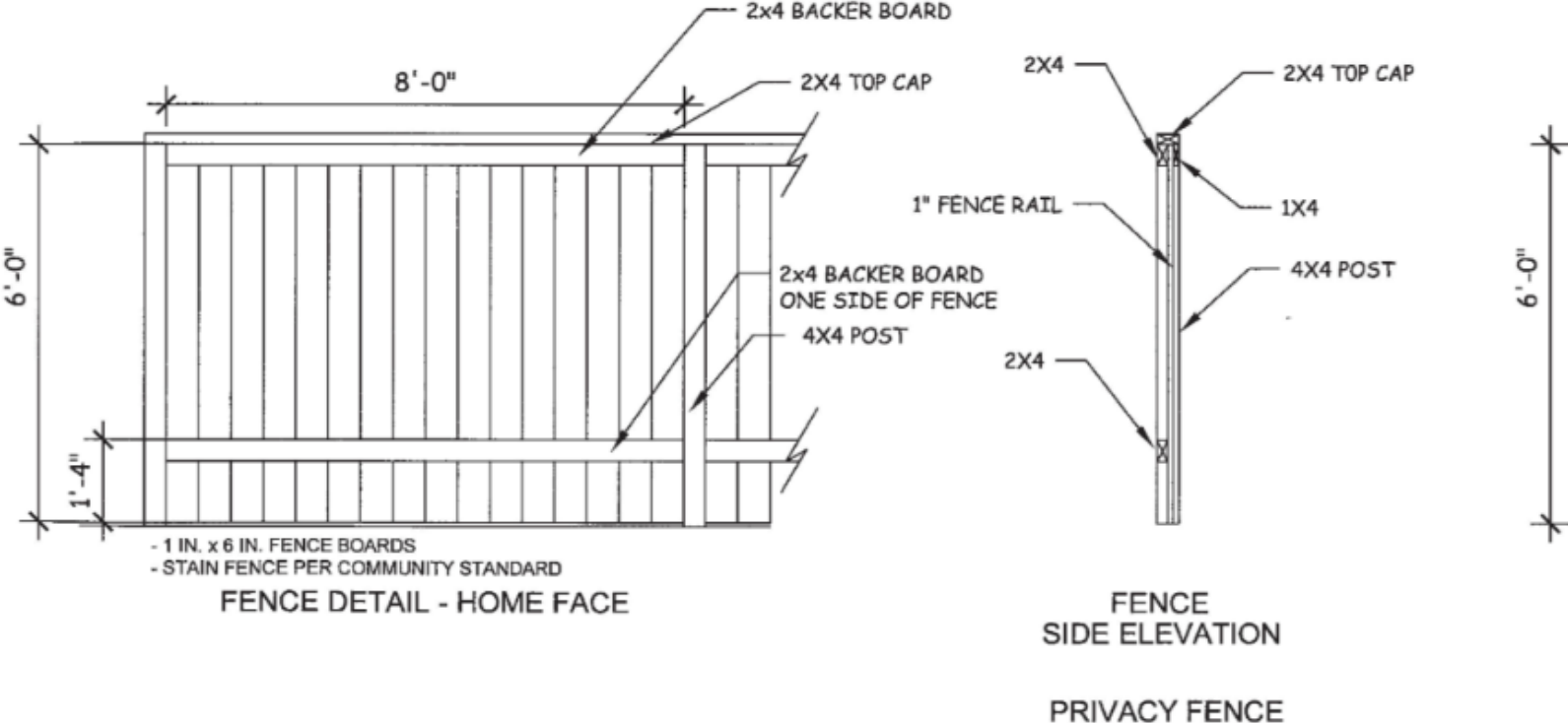

**FENCE DETAIL**

# Exhibit G

*Contents of Applicant's Exhibit G are included in Exhibit B1 to the DRB Staff Report for DB23-0012*

# Exhibit H

***Contents of Applicant's Exhibit H are included in Exhibit B2 to the DRB Staff Report for DB23-0012***