

**CITY OF WILSONVILLE
COOPERATIVE PURCHASE
GOODS AND SERVICES CONTRACT**

This Cooperative Procurement Goods and Services Contract (“Contract”) for the Asphalt Patch Truck Purchase Project (“Project”) is made and entered into on this ____ day of November 2023 (“Effective Date”) by and between the **City of Wilsonville**, a municipal corporation of the State of Oregon (hereinafter referred to as the “City”), and **PTG Oregon, LLC**, a Delaware limited liability company, doing business as **Premier Truck Group of Portland** (hereinafter referred to as “Supplier”).

RECITALS

WHEREAS, the Oregon Revised Statutes authorize cooperative procurements in accordance with ORS 279A.200, et seq.; and

WHEREAS, the City wishes to purchase equipment that Supplier is capable of providing, under terms and conditions hereinafter described; and

WHEREAS, Supplier represents that Supplier is qualified to perform the services described herein on the basis of specialized experience and technical expertise; and

WHEREAS, Supplier is prepared to provide such services, as the City does hereinafter require.

NOW, THEREFORE, in consideration of these mutual promises and the terms and conditions set forth herein, the parties agree as follows:

AGREEMENT

Section 1. Contract Documents

This Contract includes and incorporates by reference all of the foregoing Recitals and all of the following additional “Contract Documents,” and any and all terms and conditions set forth in such Contract Documents: State of Oregon Solicitation #DASPS-2295-20 and Supplier’s bid submitted in response thereto; Price Agreement No. 1640 with JMR Group, LLC (dba McCoy Freightliner) for Freightliner and Western Star Brand Vehicles, dated effective May 1, 2021, and all attachments thereto (the “State Contract”); Transfer of Rights and Obligations and Consent (Assignment & Assumption) of Price Agreement No. 1640 to PTG Oregon, LLC (dba Premier Truck Group), dated effective November 15, 2021; Amendment No. 1 to Price Agreement No. 1640, dated January 6, 2022; Amendment No. 2 to Master Blanket Purchase Order No. PO-10700-00004663, dated February 10, 2023; Amendment No. 3 to Price Agreement No. PO-10700-00004663, dated July 25, 2022; and the provisions of Oregon Revised Statutes (ORS) 279C, as more particularly set forth in this Contract. Any conflict between this Contract and the State Contract shall be resolved in favor of this Contract. This Contract, the attached exhibits, and the State Contract and amendments thereto shall be collectively referred to as the “Contract Documents.” All Contract

Documents should be read in concert and Supplier is required to bring any perceived inconsistencies to the attention of the City before executing this Contract. In the event a provision of this Contract conflicts with standards or requirements contained in any of the foregoing Contract Documents, the provision that is more favorable to the City, as determined by the City, will apply.

Section 2. Goods Purchased

Supplier will supply the new equipment described on the Quotation, attached hereto as **Exhibit A** and incorporated by reference herein (the “Equipment”).

Section 3. Equipment Price and Delivery

The price of the Equipment is TWO HUNDRED EIGHTY-FIVE THOUSAND FIVE HUNDRED TEN DOLLARS AND EIGHTY-FOUR CENTS (\$285,510.84), as shown on **Exhibit A**, and includes delivery to 28879 SW Boberg Road, Wilsonville, Oregon 7070 (“Delivery Location”). Sale shall occur upon inspection of the Equipment and acceptance of delivery at the Delivery Location. The City will pay Supplier in full within 30 days of receipt and acceptance of delivery of the Equipment. Supplier will schedule a date and time for delivery. Delivery must occur on or before June 30, 2024.

3.1. The Equipment Price is all inclusive and includes, but is not limited to, all work-related costs, expenses, salaries or wages, plus fringe benefits and contributions, including payroll taxes, workers compensation insurance, liability insurance, profit, pension benefits, and all other contributions and benefits, technology and/or software charges, licensing, trademark, and/or copyright costs, office expenses, travel expenses, mileage, and all other indirect and overhead charges, including, but not limited to, the Oregon Corporate Activity Tax (CAT).

Section 4. Term

Unless earlier terminated in accordance herewith, the term of this Contract shall be from the Effective Date until June 30, 2024. Any extension option must be exercised by the City, in writing, prior to expiration of the Initial Term of this Contract or any subsequent Extension Term.

Section 5. Subcontractors and Assignments

Supplier shall not assign any of Supplier’s rights acquired hereunder without obtaining prior written approval from the City. Some Work may be performed by persons other than Supplier, provided Supplier advises the City of the names of such subcontractors and the services which they intend to provide, and the City specifically agrees, in writing, to such subcontracting. The City hereby agrees that Supplier will contract with Thermo-Lay Manufacturing to provide and install its asphalt patch equipment, which is a critical part of this Contract. Supplier acknowledges such services will be provided to the City pursuant to a subcontract(s) between Supplier and subcontractor(s) and no privity of contract exists between the City and the subcontractor(s). Unless otherwise specifically provided by this Contract, the City incurs no liability to third persons for payment of any compensation provided herein to Supplier. Any attempted assignment of this Contract without the written consent of the City shall be void. Except as otherwise specifically

agreed, all costs for services performed by others on behalf of Supplier shall not be subject to additional reimbursement by the City.

Section 6. Warranties.

Supplier hereby agrees that Supplier will timely and thoroughly perform all warranty work. Work will be performed at the City's location unless the work cannot reasonably be performed on site. In that case, Supplier will be responsible for transporting the Equipment in need of warranty work from Wilsonville and back to Wilsonville. Supplier agrees to provide full warranty for labor and materials for all Equipment delivered to the City for a length of time not less than the manufacturer warranty for the specific Equipment. All warranties are from the date of delivery and acceptance by the City, and are in addition to, and not in lieu of, any other warranties provided by various manufacturers. Equipment warranties are attached hereto as **Exhibits B1 and B2**.

Section 7. Insurance

7.1. Insurance Requirements. Supplier must maintain insurance coverage acceptable to the City in full force and effect throughout the term of this Contract. Such insurance shall cover all risks arising directly or indirectly out of Supplier's activities or Work hereunder. The amount of insurance carried is in no way a limitation on Supplier's liability hereunder. The policy or policies maintained by Supplier shall provide at least the following minimum limits and coverages at all times during performance of this Contract:

7.1.1. Commercial General Liability Insurance. Supplier shall obtain, at Supplier's expense, and keep in effect during the term of this Contract, comprehensive Commercial General Liability Insurance covering Bodily Injury and Property Damage, written on an "occurrence" form policy. This coverage shall include broad form Contractual Liability insurance for the indemnities provided under this Contract and shall be for the following minimum insurance coverage amounts: The coverage shall be in the amount of **\$2,000,000** for each occurrence and **\$3,000,000** general aggregate and shall include Products-Completed Operations Aggregate in the minimum amount of **\$2,000,000** per occurrence, Fire Damage (any one fire) in the minimum amount of **\$50,000**, and Medical Expense (any one person) in the minimum amount of **\$10,000**. All of the foregoing coverages must be carried and maintained at all times during this Contract.

7.1.2. Business Automobile Liability Insurance. If Supplier will be using a motor vehicle in the performance of the Work herein, Supplier shall provide the City a certificate indicating that Supplier has business automobile liability coverage for all owned, hired, and non-owned vehicles. The Combined Single Limit per occurrence shall not be less than **\$2,000,000**.

7.1.3. Workers Compensation Insurance. Supplier and all employers providing work, labor, or materials under this Contract that are subject employers under the Oregon Workers Compensation Law shall comply with ORS 656.017, which requires them to provide workers compensation coverage that satisfies Oregon law for all their subject workers under ORS 656.126. Out-of-state employers must provide Oregon workers

compensation coverage for their workers who work at a single location within Oregon for more than thirty (30) days in a calendar year. Suppliers who perform work without the assistance or labor of any employee need not obtain such coverage. This shall include Employer's Liability Insurance with coverage limits of not less than **\$500,000** each accident.

7.1.4. Insurance Carrier Rating. Coverages provided by Supplier must be underwritten by an insurance company deemed acceptable by the City, with an AM Best Rating of A or better. The City reserves the right to reject all or any insurance carrier(s) with a financial rating that is unacceptable to the City.

7.1.5. Additional Insured and Termination Endorsements. The City will be named as an additional insured with respect to Supplier's liabilities hereunder in insurance coverages. Additional Insured coverage under Supplier's Commercial General Liability, Automobile Liability, and Excess Liability Policies, as applicable, will be provided by endorsement. Additional insured coverage shall be for both ongoing operations via ISO Form CG 2010 or its equivalent, and products and completed operations via ISO Form CG 2037 or its equivalent. Coverage shall be Primary and Non-Contributory. Waiver of Subrogation endorsement via ISO Form CG 2404 or its equivalent shall be provided. The following is included as additional insured: "The City of Wilsonville, its elected and appointed officials, officers, agents, employees, and volunteers." An endorsement shall also be provided requiring the insurance carrier to give the City at least thirty (30) days' written notification of any termination or major modification of the insurance policies required hereunder.

7.1.6. Certificates of Insurance. As evidence of the insurance coverage required by this Contract, Supplier shall furnish a Certificate of Insurance to the City. This Contract shall not be effective until the required certificates and the Additional Insured Endorsements have been received and approved by the City. Supplier agrees that it will not terminate or change its coverage during the term of this Contract without giving the City at least thirty (30) days' prior advance notice and Supplier will obtain an endorsement from its insurance carrier, in favor of the City, requiring the carrier to notify the City of any termination or change in insurance coverage, as provided above.

7.2. Primary Coverage. The coverage provided by these policies shall be primary, and any other insurance carried by the City is excess. Supplier shall be responsible for any deductible amounts payable under all policies of insurance. If insurance policies are "Claims Made" policies, Supplier will be required to maintain such policies in full force and effect throughout any warranty period.

Section 8. Contract Modification; Change Orders

Any modification of the provisions of this Contract shall not be enforceable or binding unless reduced to writing and signed by both the City and Supplier.

Section 9. Notices

Any notice required or permitted under this Contract shall be in writing and shall be given when actually delivered in person or forty-eight (48) hours after having been deposited in the United States mail as certified or registered mail, addressed to the addresses set forth below, or to such other address as one party may indicate by written notice to the other party.

To City: City of Wilsonville
Attn: Scott Simonton
29799 SW Town Center Loop East
Wilsonville, OR 97070

To Supplier: PTG Oregon, LLC,
dba Premier Truck Group of Oregon
Attn: Dylan Dripps
9622 NE Vancouver Way
Portland OR 97211

Section 10. Miscellaneous Provisions

10.1. Legal Effect and Assignment. This Contract shall be binding upon and inure to the benefit of the parties hereto and their respective heirs, personal representatives, successors, and assigns. This Contract may be enforced by an action at law or in equity.

10.2. No Assignment. Supplier may not delegate the performance of any obligation to a third party unless mutually agreed, in writing.

10.3. Governing Law. This Contract shall be construed in accordance with and governed by the laws of the State of Oregon, regardless of any conflicts of laws. All contractual provisions required by ORS Chapters 279A, 279B, 279C, and related Oregon Administrative Rules to be included in public agreements are hereby incorporated by reference and shall become a part of this Contract as if fully set forth herein.

10.4. Jurisdiction. Jurisdiction and venue for any dispute will be in Clackamas County Circuit Court.

10.5. Time of the Essence. Time is expressly made of the essence in the performance of this Contract.

10.6. Entire Agreement. This Contract, all documents attached to this Contract, and all Contract Documents and laws and regulations incorporated by reference herein represent the entire agreement between the parties.

10.7. Counterparts. This Contract may be executed in one or more counterparts, each of which shall constitute an original Contract but all of which together shall constitute one and the same instrument.

10.8. Authority. Each party signing on behalf of Supplier and the City hereby warrants actual authority to bind their respective party.

The Supplier and the City hereby agree to all provisions of this Contract.

SUPPLIER:

PTG OREGON, LLC,
dba Premier Truck Group of Portland

By: _____

Print Name: _____

As Its: _____

EIN/Tax I.D. No. _____

CITY:

CITY OF WILSONVILLE

By: _____

Print Name: _____

As Its: _____

APPROVED AS TO FORM:

Amanda Guile-Hinman, City Attorney
City of Wilsonville, Oregon

EXHIBIT A

Prepared for:
Martin Montalvo
WILSONVILLE CITY OF
29799 SW town Center Loop
Wilsonville, OR 97070
Phone: 503-570-1560

Prepared by:
Dylan Dripps
PREMIER TRUCK GROUP OF
PORTLAND
9622 N.E. VANCOUVER WAY
PORTLAND, OR 97211
Phone: 503-283-0345

A proposal for CITY OF WILSONVILLE through DEPARTMENT OF ADMINISTRATIVE SERVICES PA 4663 and SOURCEWELL

Prepared by
PREMIER TRUCK GROUP OF PORTLAND
Dylan Dripps

Oct 12, 2023

2025 Freightliner M2 106 Plus
Contract chassis price \$114,844.00
Thermo-Lay quote 4.25CY \$168,647.84
Est. OR CAT Tax \$1,019.00
Your package Price \$285,510.84



Components shown may not reflect all spec'd options and are not to scale

Application Version 11.9.202
Data Version PRL-28M.015
Copy of 106 PLUS model - Wilsonville
oil



10/12/2023 1:24 PM

Page 1 of 23

Prepared for:
 Martin Montalvo
 WILSONVILLE CITY OF
 29799 SW town Center Loop
 Wilsonville, OR 97070
 Phone: 503-570-1560

Prepared by:
 Dylan Dripps
 PREMIER TRUCK GROUP OF
 PORTLAND
 9622 N.E. VANCOUVER WAY
 PORTLAND, OR 97211
 Phone: 503-283-0345

Q U O T A T I O N

M2 106 PLUS CONVENTIONAL CHASSIS

SET BACK AXLE - TRUCK
 CUM L9 360 HP @ 2200 RPM; 2200 GOV RPM, 1150 LB-
 FT @ 1200 RPM
 ALLISON 3000 RDS AUTOMATIC TRANSMISSION WITH
 PTO PROVISION
 RS-30-185 30,000# U-SERIES SINGLE REAR AXLE
 30,000# FLAT LEAF SPRING REAR SUSPENSION WITH
 RADIUS ROD
 DETROIT DA-F-12.0-3 12,000# FF1 71.5 KPI/3.74 DROP
 SINGLE FRONT AXLE
 14,600# FLAT LEAF FRONT SUSPENSION

106 INCH BBC FLAT ROOF ALUMINUM CONVENTIONAL
 CAB
 4875MM (192 INCH) WHEELBASE
 NO FIFTH WHEEL
 11/32X3-1/2X10-15/16 INCH STEEL FRAME
 (8.73MMX277.8MM/0.344X10.94 INCH) 120KSI
 1900MM (75 INCH) REAR FRAME OVERHANG
 1/4 INCH (6.35MM) C-CHANNEL INNER FRAME
 REINFORCEMENT

		PER UNIT		TOTAL
VEHICLE PRICE	TOTAL # OF UNITS (1)	\$ 114,844	\$	114,844
EXTENDED WARRANTY		\$ 0	\$	0
DEALER INSTALLED OPTIONS		\$ 168,647.84	\$	168,647.84
CUSTOMER PRICE BEFORE TAX		\$ 283,491.84	\$	283,491.84

TAXES AND FEES

TAXES AND FEES	\$	1,019	\$	1,019
OTHER CHARGES	\$	0	\$	0

TRADE-IN

TRADE-IN ALLOWANCE	\$	(0)	\$	(0)
---------------------------	----	-----	----	-----

BALANCE DUE		(LOCAL CURRENCY) \$ 284,510.84		\$ 284,510.84
--------------------	--	---------------------------------------	--	----------------------

COMMENTS:

Projected delivery on ___ / ___ / ___ provided the order is received before ___ / ___ / ___.

APPROVAL:

Please indicate your acceptance of this quotation by signing below:

Customer: X _____ Date: ___ / ___ / ___.

Daimler Truck Financial

Financing that works for you.

See your local dealer for a competitive quote from Daimler Truck Financial, or contact us at Information@dtfoffers.com.

Daimler Truck Financial offers a variety of finance, lease and insurance solutions to fit your business needs. For more information about our products and services, visit our website at www.daimler-truckfinancial.com.



Prepared for:
 Martin Montalvo
 WILSONVILLE CITY OF
 29799 SW town Center Loop
 Wilsonville, OR 97070
 Phone: 503-570-1560

Prepared by:
 Dylan Dripps
 PREMIER TRUCK GROUP OF
 PORTLAND
 9622 N.E. VANCOUVER WAY
 PORTLAND, OR 97211
 Phone: 503-283-0345

S P E C I F I C A T I O N P R O P O S A L

Data Code	Description	Weight Front	Weight Rear
Price Level			
PRL-28M	M2 PRL-28M (EFF:MY25 ORDERS)		
Data Version			
DRL-015	SPECPRO21 DATA RELEASE VER 015		
Vehicle Configuration			
001-172	M2 106 PLUS CONVENTIONAL CHASSIS	5,709	3,450
004-225	2025 MODEL YEAR SPECIFIED		
002-004	SET BACK AXLE - TRUCK		
019-006	TRAILER TOWING PROVISION AT END OF FRAME WITH SAE J560	10	10
003-001	LH PRIMARY STEERING LOCATION		
General Service			
AA1-003	TRUCK/TRAILER CONFIGURATION		
AA6-001	DOMICILED, USA 50 STATES (INCLUDING CALIFORNIA AND CARB OPT-IN STATES)		
A85-010	UTILITY/REPAIR/MAINTENANCE SERVICE		
A84-1GM	GOVERNMENT BUSINESS SEGMENT		
AA4-010	DIRT/SAND/ROCK COMMODITY		
AA5-002	TERRAIN/DUTY: 100% (ALL) OF THE TIME, IN TRANSIT, IS SPENT ON PAVED ROADS		
AB1-012	MAXIMUM 12% EXPECTED GRADE		
AB5-002	ROUGH, MAINTAINED, CONCRETE OR ASPHALT PAVEMENT - MOST SEVERE IN-TRANSIT (BETWEEN SITES) ROAD SURFACE		
995-091	MEDIUM TRUCK WARRANTY		
A66-99D	EXPECTED FRONT AXLE(S) LOAD : 12000.0 lbs		
A68-99D	EXPECTED REAR DRIVE AXLE(S) LOAD : 30000.0 lbs		
A63-99D	EXPECTED GROSS VEHICLE WEIGHT CAPACITY : 42000.0 lbs		
A70-99D	EXPECTED GROSS COMBINATION WEIGHT : 80000.0 lbs		



Prepared for:
 Martin Montalvo
 WILSONVILLE CITY OF
 29799 SW town Center Loop
 Wilsonville, OR 97070
 Phone: 503-570-1560

Prepared by:
 Dylan Dripps
 PREMIER TRUCK GROUP OF
 PORTLAND
 9622 N.E. VANCOUVER WAY
 PORTLAND, OR 97211
 Phone: 503-283-0345

Data Code	Description	Weight Front	Weight Rear
Truck Service			
AA3-003	TANK BODY		
AF3-2G2	ABC SUPPLY CO., INC.		
AF7-99D	EXPECTED BODY/PAYLOAD CG HEIGHT ABOVE FRAME "XX" INCHES : 32.0 in		
Tractor Service			
AA2-005	FLATBED TRAILER		
AH6-001	SINGLE (1) TRAILER		
Engine			
101-3BR	CUM L9 360 HP @ 2200 RPM; 2200 GOV RPM, 1150 LB-FT @ 1200 RPM	640	30
Electronic Parameters			
79A-065	65 MPH ROAD SPEED LIMIT		
79B-000	CRUISE CONTROL SPEED LIMIT SAME AS ROAD SPEED LIMIT		
79G-105	5 MINUTE IDLE SHUTDOWN - CONTINUOUS OVERRIDE WITH CLUTCH AND SERVICE BRAKE		
79K-014	PTO MODE ENGINE RPM LIMIT - 1800 RPM		
79M-001	PTO MODE BRAKE OVERRIDE - SERVICE BRAKE APPLIED		
79P-002	PTO RPM WITH CRUISE SET SWITCH - 700 RPM		
79Q-002	PTO RPM WITH CRUISE RESUME SWITCH - 700 RPM		
79S-008	PTO MODE CANCEL VEHICLE SPEED - 25 MPH		
79U-007	PTO GOVERNOR RAMP RATE - 250 RPM PER SECOND		
79W-001	ONE REMOTE PTO SPEED		
79X-007	PTO SPEED 1 SETTING - 1000 RPM		
80G-002	PTO MINIMUM RPM - 700		
80J-002	REGEN INHIBIT SPEED THRESHOLD - 5 MPH		
80S-015	PTO 1, NO SWITCH, TEM SUPPLIED REQUEST, FEEDBACK AND INTERLOCKS, WITH PTO CONNECTIONS, ROLLING INTERLOCKS		
80T-015	PTO 2, NO SWITCH, TEM SUPPLIED REQUEST AND INTERLOCKS, WITH PTO CONNECTIONS, ROLLING INTERLOCKS		
Engine Equipment			
99C-124	EPA 2010 GHG 2024/CARB 2024 ULTRALOW NOX CONFIGURATION		
13E-001	STANDARD OIL PAN		



Prepared for:
 Martin Montalvo
 WILSONVILLE CITY OF
 29799 SW town Center Loop
 Wilsonville, OR 97070
 Phone: 503-570-1560

Prepared by:
 Dylan Dripps
 PREMIER TRUCK GROUP OF
 PORTLAND
 9622 N.E. VANCOUVER WAY
 PORTLAND, OR 97211
 Phone: 503-283-0345

Data Code	Description	Weight Front	Weight Rear
105-001	ENGINE MOUNTED OIL CHECK AND FILL		
014-099	SIDE OF HOOD AIR INTAKE WITH FIREWALL MOUNTED DONALDSON AIR CLEANER		
124-1D7	DR 12V 160 AMP 28-SI QUADRAMOUNT PAD ALTERNATOR WITH REMOTE BATTERY VOLT SENSE		
292-235	(2) DTNA GENUINE, FLOODED STARTING, MIN 2000CCA, 370RC, THREADED STUD BATTERIES	10	
290-017	BATTERY BOX FRAME MOUNTED		
281-001	STANDARD BATTERY JUMPERS		
282-001	SINGLE BATTERY BOX FRAME MOUNTED LH SIDE UNDER CAB		
291-017	WIRE GROUND RETURN FOR BATTERY CABLES WITH ADDITIONAL FRAME GROUND RETURN		
289-001	NON-POLISHED BATTERY BOX COVER		
293-058	POSITIVE LOAD DISCONNECT WITH CAB MOUNTED CONTROL SWITCH MOUNTED OUTBOARD DRIVER SEAT	2	
295-029	POSITIVE AND NEGATIVE POSTS FOR JUMPSTART LOCATED ON FRAME NEXT TO STARTER	2	
306-015	PROGRESSIVE LOW VOLTAGE DISCONNECT AT 12.3 VOLTS FOR DESIGNATED CIRCUITS		
107-032	CUMMINS TURBOCHARGED 18.7 CFM AIR COMPRESSOR WITH INTERNAL SAFETY VALVE		
108-002	STANDARD MECHANICAL AIR COMPRESSOR GOVERNOR		
131-013	AIR COMPRESSOR DISCHARGE LINE		
152-040	ELECTRONIC ENGINE INTEGRAL WARNING AND DERATE PROTECTION SYSTEM		
128-032	C-BRAKE BY JACOBS WITH LOW/OFF/HIGH BRAKING DASH SWITCH	80	
016-1C2	RH OUTBOARD UNDER STEP MOUNTED HORIZONTAL AFTERTREATMENT SYSTEM ASSEMBLY WITH RH B-PILLAR MOUNTED VERTICAL TAILPIPE	30	25
28F-014	ENGINE AFTERTREATMENT DEVICE, AUTOMATIC OVER THE ROAD REGENERATION AND VIRTUAL REGENERATION REQUEST SWITCH IN CLUSTER		
239-026	10 FOOT 06 INCH (126 INCH+0/-5.9 INCH) EXHAUST SYSTEM HEIGHT		
233-017	STANDARD CURVE BRIGHT UPPER STACK(S)		
237-1CR	RH CURVED VERTICAL TAILPIPE B-PILLAR MOUNTED ROUTED FROM STEP		



Prepared for:
 Martin Montalvo
 WILSONVILLE CITY OF
 29799 SW town Center Loop
 Wilsonville, OR 97070
 Phone: 503-570-1560

Prepared by:
 Dylan Dripps
 PREMIER TRUCK GROUP OF
 PORTLAND
 9622 N.E. VANCOUVER WAY
 PORTLAND, OR 97211
 Phone: 503-283-0345

Data Code	Description	Weight Front	Weight Rear
23U-001	6 GALLON DIESEL EXHAUST FLUID TANK		
30N-003	100 PERCENT DIESEL EXHAUST FLUID FILL		
43X-002	LH MEDIUM DUTY STANDARD DIESEL EXHAUST FLUID TANK LOCATION		
23Y-001	STANDARD DIESEL EXHAUST FLUID PUMP MOUNTING		
43Y-001	STANDARD DIESEL EXHAUST FLUID TANK CAP		
242-001	STAINLESS STEEL AFTERTREATMENT DEVICE/MUFFLER/TAILOPIPE SHIELD		
273-060	HIGH SPEED AIR POWERED ON/OFF ENGINE FAN CLUTCH		
276-002	AUTOMATIC FAN CONTROL WITH DASH SWITCH AND INDICATOR LIGHT, NON ENGINE MOUNTED		
110-003	CUMMINS SPIN ON FUEL FILTER		
118-008	COMBINATION FULL FLOW/BYPASS OIL FILTER		
266-101	900 SQUARE INCH ALUMINUM RADIATOR	15	
103-036	ANTIFREEZE TO -34F, ETHYLENE GLYCOL PRE-CHARGED SCA HEAVY DUTY COOLANT		
171-007	GATES BLUE STRIPE COOLANT HOSES OR EQUIVALENT		
172-001	CONSTANT TENSION HOSE CLAMPS FOR COOLANT HOSES		
270-016	RADIATOR DRAIN VALVE		
168-998	NO RADIATOR/OIL PAN GUARD	-5	
138-011	PHILLIPS-TEMRO 1000 WATT/115 VOLT BLOCK HEATER	4	
140-022	CHROME ENGINE HEATER RECEPTACLE MOUNTED UNDER LH DOOR		
134-001	ALUMINUM FLYWHEEL HOUSING		
132-004	ELECTRIC GRID AIR INTAKE WARMER		
155-055	DELCO 12V 39MT HD/OCP STARTER WITH THERMAL PROTECTION AND INTEGRATED MAGNETIC SWITCH	15	

Transmission

342-582	ALLISON 3000 RDS AUTOMATIC TRANSMISSION WITH PTO PROVISION	200	60
---------	--	-----	----

Transmission Equipment

343-339	ALLISON VOCATIONAL PACKAGE 223 - AVAILABLE ON 3000/4000 PRODUCT FAMILIES WITH VOCATIONAL MODELS RDS, HS, MH AND TRV		
---------	---	--	--



Prepared for:
 Martin Montalvo
 WILSONVILLE CITY OF
 29799 SW town Center Loop
 Wilsonville, OR 97070
 Phone: 503-570-1560

Prepared by:
 Dylan Dripps
 PREMIER TRUCK GROUP OF
 PORTLAND
 9622 N.E. VANCOUVER WAY
 PORTLAND, OR 97211
 Phone: 503-283-0345

Data Code	Description	Weight Front	Weight Rear
84B-012	ALLISON VOCATIONAL RATING FOR ON/OFF HIGHWAY APPLICATIONS AVAILABLE WITH ALL PRODUCT FAMILIES		
84C-023	PRIMARY MODE GEARS, LOWEST GEAR 1, START GEAR 1, HIGHEST GEAR 6, AVAILABLE FOR 3000/4000 PRODUCT FAMILIES ONLY		
84D-023	SECONDARY MODE GEARS, LOWEST GEAR 1, START GEAR 1, HIGHEST GEAR 6, AVAILABLE FOR 3000/4000 PRODUCT FAMILIES ONLY		
84E-017	S5 PERFORMANCE LIMITING PRIMARY SHIFT SCHEDULE, AVAILABLE FOR 3000/4000 PRODUCT FAMILIES ONLY		
84F-016	S5 PERFORMANCE LIMITING SECONDARY SHIFT SCHEDULE, AVAILABLE FOR 3000/4000 PRODUCT FAMILIES ONLY		
84G-013	2100 RPM PRIMARY MODE SHIFT SPEED		
84H-013	2100 RPM SECONDARY MODE SHIFT SPEED		
84J-000	ENGINE BRAKE RANGE PRESELECT RECOMMENDED BY DTNA AND ALLISON, THIS DEFINED BY ENGINE AND VOCATIONAL USAGE		
84K-000	ENGINE BRAKE RANGE ALTERNATE PRESELECT RECOMMENDED BY DTNA AND ALLISON, THIS DEFINED BY ENGINE AND VOCATIONAL USAGE		
84N-011	NEUTRAL AT STOP ENABLED		
84U-000	DRIVER SWITCH INPUT - DEFAULT - NO SWITCHES		
85E-011	MAXIMUM ENGINE SPEED FOR PTO ENGAGEMENT 1000 RPM		
85F-034	MAXIMUM ENGINE SPEED FOR PTO OPERATION 2000 RPM		
85H-079	MAXIMUM OUTPUT SPEED FOR PTO OPERATION 2000 RPM - ALLISON 5TH GEN TRANSMISSIONS		
353-073	QUICKFIT BODY LIGHTING CONNECTOR UNDER CAB, WITH CAP		
34C-011	ELECTRONIC TRANSMISSION WIRING TO CUSTOMER INTERFACE CONNECTOR		
362-824	(2) CUSTOMER INSTALLED CHELSEA 280 SERIES PTO'S		
363-010	PTO MOUNTING, LH SIDE AND TOP RH SIDE OF MAIN TRANSMISSION ALLISON		
341-018	MAGNETIC PLUGS, ENGINE DRAIN, TRANSMISSION DRAIN, AXLE(S) FILL AND DRAIN		



Prepared for:
 Martin Montalvo
 WILSONVILLE CITY OF
 29799 SW town Center Loop
 Wilsonville, OR 97070
 Phone: 503-570-1560

Prepared by:
 Dylan Dripps
 PREMIER TRUCK GROUP OF
 PORTLAND
 9622 N.E. VANCOUVER WAY
 PORTLAND, OR 97211
 Phone: 503-283-0345

Data Code	Description	Weight Front	Weight Rear
345-003	PUSH BUTTON ELECTRONIC SHIFT CONTROL, DASH MOUNTED		
97G-004	TRANSMISSION PROGNOSTICS - ENABLED 2013		
370-015	WATER TO OIL TRANSMISSION COOLER, IN RADIATOR END TANK		
346-003	TRANSMISSION OIL CHECK AND FILL WITH ELECTRONIC OIL LEVEL CHECK		
35T-001	SYNTHETIC TRANSMISSION FLUID (TES-295 COMPLIANT)		

Front Axle and Equipment

400-1A6	DETROIT DA-F-12.0-3 12,000# FF1 71.5 KPI/3.74 DROP SINGLE FRONT AXLE		
402-1A4	MERITOR EX-L OPTIMIZED AXIAL AIR DISC FRONT BRAKES	10	
403-002	NON-ASBESTOS FRONT BRAKE LINING		
419-004	FRONT DISC BRAKE ROTORS		
427-001	FRONT BRAKE DUST SHIELDS	5	
409-006	FRONT OIL SEALS		
408-001	VENTED FRONT HUB CAPS WITH WINDOW, CENTER AND SIDE PLUGS - OIL		
416-022	STANDARD SPINDLE NUTS FOR ALL AXLES		
405-030	FRONT AIR DISC BRAKE INTERNAL ADJUSTERS		
536-050	TRW THP-60 POWER STEERING		
539-003	POWER STEERING PUMP		
534-015	2 QUART SEE THROUGH POWER STEERING RESERVOIR		
40T-002	CURRENT AVAILABLE SYNTHETIC 75W-90 FRONT AXLE LUBE		

Front Suspension

620-003	14,600# FLAT LEAF FRONT SUSPENSION	250	
619-004	GRAPHITE BRONZE BUSHINGS WITH SEALS - FRONT SUSPENSION		
410-998	NO FRONT SHOCK ABSORBERS	-30	

Rear Axle and Equipment

420-024	RS-30-185 30,000# U-SERIES SINGLE REAR AXLE		275
421-538	5.38 REAR AXLE RATIO		
424-001	IRON REAR AXLE CARRIER WITH STANDARD AXLE HOUSING		
386-073	MXL 17T MERITOR EXTENDED LUBE MAIN DRIVELINE WITH HALF ROUND YOKES		



Prepared for:
 Martin Montalvo
 WILSONVILLE CITY OF
 29799 SW town Center Loop
 Wilsonville, OR 97070
 Phone: 503-570-1560

Prepared by:
 Dylan Dripps
 PREMIER TRUCK GROUP OF
 PORTLAND
 9622 N.E. VANCOUVER WAY
 PORTLAND, OR 97211
 Phone: 503-283-0345

Data Code	Description	Weight Front	Weight Rear
452-001	DRIVER CONTROLLED TRACTION DIFFERENTIAL - SINGLE REAR AXLE		20
878-018	(1) DRIVER CONTROLLED DIFFERENTIAL LOCK REAR VALVE FOR SINGLE DRIVE AXLE		
87B-008	INDICATOR LIGHT FOR EACH DIFFERENTIAL LOCKOUT SWITCH		
423-010	MERITOR 16.5X7 P CAST SPIDER CAM REAR BRAKES, DOUBLE ANCHOR, CAST SHOES		20
433-002	NON-ASBESTOS REAR BRAKE LINING		
434-012	BRAKE CAMS AND CHAMBERS ON REAR SIDE OF DRIVE AXLE(S)		
451-018	WEBB CAST IRON REAR BRAKE DRUMS		50
425-002	REAR BRAKE DUST SHIELDS		5
440-006	REAR OIL SEALS		
426-100	WABCO TRISTOP D LONGSTROKE 1-DRIVE AXLE SPRING PARKING CHAMBERS		
428-003	HALDEX AUTOMATIC REAR SLACK ADJUSTERS		
41T-002	CURRENT AVAILABLE SYNTHETIC 75W-90 REAR AXLE LUBE		

Rear Suspension

622-1DB	30,000# FLAT LEAF SPRING REAR SUSPENSION WITH RADIUS ROD		120
621-001	SPRING SUSPENSION - NO AXLE SPACERS		
431-001	STANDARD AXLE SEATS IN AXLE CLAMP GROUP		
623-005	FORE/AFT CONTROL RODS		

Pusher / Tag Equipment

429-998	NO PUSHER/TAG BRAKE DUST SHIELDS		
---------	----------------------------------	--	--

Brake System

018-002	AIR BRAKE PACKAGE		
490-1AU	WABCO 4S/4M ABS WITH TRACTION CONTROL WITH ATC SHUT OFF SWITCH		
871-001	REINFORCED NYLON, FABRIC BRAID AND WIRE BRAID CHASSIS AIR LINES		
904-001	FIBER BRAID PARKING BRAKE HOSE		
412-001	STANDARD BRAKE SYSTEM VALVES		
46D-002	STANDARD AIR SYSTEM PRESSURE PROTECTION SYSTEM		
413-002	STD U.S. FRONT BRAKE VALVE		
432-003	RELAY VALVE WITH 5-8 PSI CRACK PRESSURE, NO REAR PROPORTIONING VALVE		



Prepared for:
 Martin Montalvo
 WILSONVILLE CITY OF
 29799 SW town Center Loop
 Wilsonville, OR 97070
 Phone: 503-570-1560

Prepared by:
 Dylan Dripps
 PREMIER TRUCK GROUP OF
 PORTLAND
 9622 N.E. VANCOUVER WAY
 PORTLAND, OR 97211
 Phone: 503-283-0345

Data Code	Description	Weight Front	Weight Rear
480-088	WABCO SYSTEM SAVER HP WITH INTEGRAL AIR GOVERNOR AND HEATER		
479-003	AIR DRYER MOUNTED INBOARD ON LH RAIL		
460-001	STEEL AIR BRAKE RESERVOIRS		
477-001	PULL CABLE ON WET TANK, PETCOCK DRAIN VALVES ON ALL OTHER AIR TANKS		
485-003	QUICK DISCONNECT FITTING WITH TIRE INFLATION KIT	2	

Trailer Connections

481-998	NO TRAILER AIR HOSE		
476-998	NO AIR HOSE HANGER		
914-025	AIR CONNECTIONS TO END OF FRAME WITH GLAD HANDS FOR TRUCK AND DUST COVERS		
296-010	PRIMARY CONNECTOR/RECEPTACLE WIRED FOR SEPARATE STOP/TURN, ABS CENTER PIN POWERED THROUGH IGNITION		
303-025	SAE J560 7-WAY PRIMARY TRAILER CABLE RECEPTACLE MOUNTED END OF FRAME		
310-998	NO TRAILER ELECTRICAL CABLE		

Wheelbase & Frame

545-487	4875MM (192 INCH) WHEELBASE		
546-101	11/32X3-1/2X10-15/16 INCH STEEL FRAME (8.73MMX277.8MM/0.344X10.94 INCH) 120KSI	120	120
547-001	1/4 INCH (6.35MM) C-CHANNEL INNER FRAME REINFORCEMENT	140	360
552-014	1900MM (75 INCH) REAR FRAME OVERHANG		
55W-007	FRAME OVERHANG RANGE: 71 INCH TO 80 INCH	-30	120
AC8-99D	CALC'D BACK OF CAB TO REAR SUSP C/L (CA) : 126.38 in		
AE8-99D	CALCULATED EFFECTIVE BACK OF CAB TO REAR SUSPENSION C/L (CA) : 123.38 in		
AE4-99D	CALC'D FRAME LENGTH - OVERALL : 305.71 in		
FSS-0LH	CALCULATED FRAME SPACE LH SIDE : 70.6 in		
FSS-0RH	CALCULATED FRAME SPACE RH SIDE : 93.76 in		
553-001	SQUARE END OF FRAME		
550-001	FRONT CLOSING CROSSMEMBER		
559-003	LIGHTWEIGHT HEAVY DUTY ALUMINUM ENGINE CROSSMEMBER	-12	
561-001	STANDARD CROSSMEMBER BACK OF TRANSMISSION		



Prepared for:
 Martin Montalvo
 WILSONVILLE CITY OF
 29799 SW town Center Loop
 Wilsonville, OR 97070
 Phone: 503-570-1560

Prepared by:
 Dylan Dripps
 PREMIER TRUCK GROUP OF
 PORTLAND
 9622 N.E. VANCOUVER WAY
 PORTLAND, OR 97211
 Phone: 503-283-0345

Data Code	Description	Weight Front	Weight Rear
562-001	STANDARD MIDSHIP #1 CROSSMEMBER(S)		
572-001	STANDARD REAR MOST CROSSMEMBER		
565-001	STANDARD SUSPENSION CROSSMEMBER		
Chassis Equipment			
556-1AP	THREE-PIECE 14 INCH PAINTED STEEL BUMPER WITH COLLAPSIBLE ENDS	30	
574-001	BUMPER MOUNTING FOR SINGLE LICENSE PLATE		
585-998	NO MUDFLAP BRACKETS		
590-998	NO REAR MUDFLAPS		
586-024	FENDER AND FRONT OF HOOD MOUNTED FRONT MUDFLAPS		
551-007	GRADE 8 THREADED HEX HEADED FRAME FASTENERS		
44Z-002	EXTERIOR HARNESSES WRAPPED IN ABRASION TAPE		
Fifth Wheel			
578-998	NO FIFTH WHEEL		
Fuel Tanks			
204-195	60 GALLON/227 LITER RECTANGULAR ALUMINUM FUEL TANK - LH	30	
218-005	RECTANGULAR FUEL TANK(S)		
215-005	PLAIN ALUMINUM/PAINTED STEEL FUEL/HYDRAULIC TANK(S) WITH PAINTED BANDS		
212-007	FUEL TANK(S) FORWARD		
664-001	PLAIN STEP FINISH		
205-001	FUEL TANK CAP(S)		
122-1H3	DETROIT FUEL/WATER SEPARATOR WITH WATER IN FUEL SENSOR	-5	
216-020	EQUIFLO INBOARD FUEL SYSTEM		
202-016	HIGH TEMPERATURE REINFORCED NYLON FUEL LINE		
Tires			
093-1VM	MICHELIN X LINE ENERGY Z 315/80R22.5 20 PLY RADIAL FRONT TIRES	50	
094-1UY	MICHELIN X MULTI D 11R22.5 16 PLY RADIAL REAR TIRES		60
Hubs			



Prepared for:
 Martin Montalvo
 WILSONVILLE CITY OF
 29799 SW town Center Loop
 Wilsonville, OR 97070
 Phone: 503-570-1560

Prepared by:
 Dylan Dripps
 PREMIER TRUCK GROUP OF
 PORTLAND
 9622 N.E. VANCOUVER WAY
 PORTLAND, OR 97211
 Phone: 503-283-0345

Data Code	Description	Weight Front	Weight Rear
418-060	CONMET PRESET PLUS PREMIUM IRON FRONT HUBS		
450-014	WEBB IRON REAR HUBS		70
Wheels			
502-433	ACCURIDE 29039 22.5X9.00 10-HUB PILOT 5.25 INSET 5-HAND STEEL DISC FRONT WHEELS	66	
505-428	ACCURIDE 28828 22.5X8.25 10-HUB PILOT 2-HAND HD STEEL DISC REAR WHEELS		52
496-011	FRONT WHEEL MOUNTING NUTS		
497-011	REAR WHEEL MOUNTING NUTS		
Cab Exterior			
829-071	106 INCH BBC FLAT ROOF ALUMINUM CONVENTIONAL CAB		
650-008	AIR CAB MOUNTING		
648-002	NONREMOVABLE BUGSCREEN MOUNTED BEHIND GRILLE		
678-001	LH AND RH GRAB HANDLES		
646-023	HOOD MOUNTED CHROMED PLASTIC GRILLE		
65X-003	CHROME HOOD MOUNTED AIR INTAKE GRILLE		
644-004	FIBERGLASS HOOD		
690-002	TUNNEL/FIREWALL LINER		
727-1AF	SINGLE 14 INCH ROUND HADLEY AIR HORN UNDER LH DECK	4	
726-001	SINGLE ELECTRIC HORN		
728-001	SINGLE HORN SHIELD		
575-001	REAR LICENSE PLATE MOUNT END OF FRAME		
312-038	INTEGRAL HEADLIGHT/MARKER ASSEMBLY WITH CHROME BEZEL		
302-047	LED AERODYNAMIC MARKER LIGHTS		
311-001	DAYTIME RUNNING LIGHTS		
294-001	INTEGRAL STOP/TAIL/BACKUP LIGHTS		
300-015	STANDARD FRONT TURN SIGNAL LAMPS		
744-1BC	DUAL WEST COAST BRIGHT FINISH HEATED MIRRORS WITH LH AND RH REMOTE		
797-001	DOOR MOUNTED MIRRORS		
796-001	102 INCH EQUIPMENT WIDTH		
743-204	LH AND RH 8 INCH BRIGHT FINISH CONVEX MIRRORS MOUNTED UNDER PRIMARY MIRRORS		
74A-001	RH DOWN VIEW MIRROR		



Prepared for:
 Martin Montalvo
 WILSONVILLE CITY OF
 29799 SW town Center Loop
 Wilsonville, OR 97070
 Phone: 503-570-1560

Prepared by:
 Dylan Dripps
 PREMIER TRUCK GROUP OF
 PORTLAND
 9622 N.E. VANCOUVER WAY
 PORTLAND, OR 97211
 Phone: 503-283-0345

Data Code	Description	Weight Front	Weight Rear
74B-005	RH VELVAC 8 INCH BRIGHT FINISH HOOD MOUNTED CONVEX MIRROR WITH SWING ARM BRACKET, DUAL VIEW	4	
729-001	STANDARD SIDE/REAR REFLECTORS		
768-043	63X14 INCH TINTED REAR WINDOW		
661-003	TINTED DOOR GLASS LH AND RH WITH TINTED NON-OPERATING WING WINDOWS		
654-011	RH AND LH ELECTRIC POWERED WINDOWS		
663-013	1-PIECE SOLAR GREEN GLASS WINDSHIELD		
659-007	8 LITER (2 GAL) WINDSHIELD WASHER RESERVOIR, CAB MOUNTED, WITHOUT FLUID LEVEL INDICATOR		

Cab Interior

055-019	RUGGED TRIM PACKAGE		
707-107	GRAY & CARBON VINYL INTERIOR "RUGGED"		
70K-020	CARBON WITH PREMIUM GUNMETAL ACCENT (RUGGED)		
706-013	MOLDED PLASTIC DOOR PANEL		
708-013	MOLDED PLASTIC DOOR PANEL		
772-006	BLACK MATS WITH SINGLE INSULATION		
785-034	ASH CUP AND (1)LIGHTER, (1)12V POWER OUTLET, (1)DASH MTD DUAL USB-C OUTLET		
691-001	FORWARD ROOF MOUNTED CONSOLE		
696-012	CENTER STORAGE CONSOLE MOUNTED ON BACKWALL	20	
693-035	LH AND RH KICKPLATES		
738-021	DIGITAL ALARM CLOCK IN DRIVER DISPLAY		
742-007	(2) CUP HOLDERS LH AND RH DASH		
680-029	M2/SD DASH		
720-003	5 LB. FIRE EXTINGUISHER	10	
700-002	HEATER, DEFROSTER AND AIR CONDITIONER		
701-008	STANDARD HVAC DUCTING WITH SNOW SHIELD FOR FRESH AIR INTAKE		
703-005	MAIN HVAC CONTROLS WITH RECIRCULATION SWITCH		
170-015	STANDARD HEATER PLUMBING		
130-041	VALEO HEAVY DUTY A/C REFRIGERANT COMPRESSOR		
702-002	BINARY CONTROL, R-134A		
739-034	PREMIUM INSULATION		



Prepared for:
 Martin Montalvo
 WILSONVILLE CITY OF
 29799 SW town Center Loop
 Wilsonville, OR 97070
 Phone: 503-570-1560

Prepared by:
 Dylan Dripps
 PREMIER TRUCK GROUP OF
 PORTLAND
 9622 N.E. VANCOUVER WAY
 PORTLAND, OR 97211
 Phone: 503-283-0345

Data Code	Description	Weight Front	Weight Rear
285-013	SOLID-STATE CIRCUIT PROTECTION AND FUSES		
280-007	12V NEGATIVE GROUND ELECTRICAL SYSTEM		
324-1B3	STANDARD LED CAB LIGHTING		
787-998	NO SECURITY DEVICE		
657-1A0	ALL UNIT(S) KEYED ALIKE WITH CUSTOMER SPECIFIED KEY NUMBER FT1013		
78G-006	KEY QUANTITY OF 6		
655-005	LH AND RH ELECTRIC DOOR LOCKS		
722-002	TRIANGULAR REFLECTORS WITHOUT FLARES	10	
756-339	PREMIUM ISRINGHAUSEN HIGH BACK AIR SUSPENSION DRIVERS SEAT WITH 2 AIR LUMBAR, INTEGRATED CUSHION EXTENSION, TILT AND ADJUSTABLE SHOCK	70	
760-339	PREMIUM ISRINGHAUSEN HIGH BACK AIR SUSPENSION PASSENGER SEAT WITH 2 AIR LUMBAR, INTEGRATED CUSHION EXTENSION, TILT AND ADJUSTABLE SHOCK	60	20
759-005	DUAL DRIVER AND PASSENGER SEAT ARMRESTS	8	
711-004	LH AND RH INTEGRAL DOOR PANEL ARMRESTS		
758-1AK	BLACK VINYL DRIVER SEAT COVER		
761-1AK	BLACK VINYL PASSENGER SEAT COVER		
763-101	BLACK SEAT BELTS		
532-002	ADJUSTABLE TILT AND TELESCOPING STEERING COLUMN		
540-070	4-SPOKE 18 INCH (450MM) LEATHER WRAPPED STEERING WHEEL WITH CHROME SWITCH BEZELS		
765-002	DRIVER AND PASSENGER INTERIOR SUN VISORS		

Instruments & Controls

106-002	ELECTRONIC ACCELERATOR CONTROL
734-023	CONFIGURABLE LOWER PANEL WITH INTEGRATED UPPER STORAGE
87L-001	ENGINE REMOTE INTERFACE WITH PARK BRAKE INTERLOCK
870-002	BRIGHT ARGENT FINISH GAUGE BEZELS
486-001	LOW AIR PRESSURE INDICATOR LIGHT AND AUDIBLE ALARM
838-001	(1) PNEUMATIC SINGLE BRAKE APPLICATION AIR GAUGE



Prepared for:
 Martin Montalvo
 WILSONVILLE CITY OF
 29799 SW town Center Loop
 Wilsonville, OR 97070
 Phone: 503-570-1560

Prepared by:
 Dylan Dripps
 PREMIER TRUCK GROUP OF
 PORTLAND
 9622 N.E. VANCOUVER WAY
 PORTLAND, OR 97211
 Phone: 503-283-0345

Data Code	Description	Weight Front	Weight Rear
840-001	DUAL NEEDLE PRIMARY AND SECONDARY AIR PRESSURE GAUGE		
198-003	DASH MOUNTED AIR RESTRICTION INDICATOR WITH GRADUATIONS		
721-001	97 DB BACKUP ALARM		3
149-015	ELECTRONIC CRUISE CONTROL WITH CONTROLS ON STEERING WHEEL SPOKES		
156-007	KEY OPERATED IGNITION SWITCH AND INTEGRAL START POSITION; 4 POSITION OFF/RUN/START/ACCESSORY		
811-044	PREMIUM INSTRUMENT CLUSTER WITH 5.0 INCH TFT COLOR DISPLAY		
81B-003	DIGITAL PANEL LAMP DIMMER SWITCH IN DRIVER DISPLAY		
160-038	HEAVY DUTY ONBOARD DIAGNOSTICS INTERFACE CONNECTOR LOCATED BELOW LH DASH		
844-001	2 INCH ELECTRIC FUEL GAUGE		
148-073	ENGINE REMOTE INTERFACE FOR REMOTE THROTTLE		
48H-003	QUICKFIT POWERTRAIN INTERFACE CONNECTOR UNDER CAB WITH CAPS		
4C0-998	NO ADDITIONAL EXTRA SWITCH ACCUATORS		
48C-003	QUICKFIT PROGRAMMABLE INTERFACE CONNECTOR(S) UNDER CAB WITH CAP		
163-014	ENGINE REMOTE INTERFACE CONNECTOR AT POWERTRAIN INTERFACE CONNECTOR		
856-001	ELECTRICAL ENGINE COOLANT TEMPERATURE GAUGE		
864-001	2 INCH TRANSMISSION OIL TEMPERATURE GAUGE		
867-004	ELECTRONIC OUTSIDE TEMPERATURE SENSOR DISPLAY IN DRIVER MESSAGE CENTER		
830-017	ENGINE AND TRIP HOUR METERS INTEGRAL WITHIN DRIVER DISPLAY		
372-123	PTO CONTROLS FOR ENHANCED VEHICLE ELECTRIC/ELECTRONIC ARCHITECTURE		
736-998	NO OBSTACLE DETECTION SYSTEM		
72J-998	NO DR ASSIST SYSTEM		
49B-998	NO VEHICLE STABILITY ADVISOR OR CONTROL		
73B-998	NO LANE DEPARTURE WARNING SYSTEM		
852-002	ELECTRIC ENGINE OIL PRESSURE GAUGE		



Prepared for:
 Martin Montalvo
 WILSONVILLE CITY OF
 29799 SW town Center Loop
 Wilsonville, OR 97070
 Phone: 503-570-1560

Prepared by:
 Dylan Dripps
 PREMIER TRUCK GROUP OF
 PORTLAND
 9622 N.E. VANCOUVER WAY
 PORTLAND, OR 97211
 Phone: 503-283-0345

	Data Code	Description	Weight Front	Weight Rear
N	679-022	LEFTHAND/RIGHTHAND OVERHEAD INSTRUMENT PANEL BLANK		
	35M-010	QUICKFIT PROGRAMMABLE INTERFACE MODULE	10	
	746-137	AM/FM/WB WORLD TUNER RADIO WITH BLUETOOTH, USB AND AUXILIARY INPUTS, J1939		
	747-001	DASH MOUNTED RADIO		
	750-002	(2) RADIO SPEAKERS IN CAB		
	753-998	NO AM/FM RADIO ANTENNA		
	748-044	UNIDEN PC78LTX FACTORY INSTALLED CB RADIO WITH SWR METER	5	
	749-001	ROOF/OVERHEAD CONSOLE CB RADIO PROVISION		
	752-017	MULTI-BAND AM/FM/WB/CB LH MIRROR MOUNTED ANTENNA SYSTEM		
	74D-006	STANDARD RADIO WIRING WITH STEERING WHEEL CONTROLS		
	810-027	ELECTRONIC MPH SPEEDOMETER WITH SECONDARY KPH SCALE, WITHOUT ODOMETER		
	817-001	STANDARD VEHICLE SPEED SENSOR		
	812-001	ELECTRONIC 3000 RPM TACHOMETER		
	813-1C8	DETROIT CONNECT PLATFORM HARDWARE		
	8D1-303	3 YEARS DAIMLER CONNECTIVITY BASE PACKAGE (FEATURES VARY BY MODEL) POWERED BY DETROIT CONNECT		
	6TS-006	TMC RP1226 ACCESSORY CONNECTOR LOCATED CENTER OF OVERHEAD CONSOLE		
	162-002	IGNITION SWITCH CONTROLLED ENGINE STOP		
	329-121	FOUR EXTRA HARDWIRED SWITCHES IN DASH, INPUT POWER, NO OUTPUT WIRING		
	4C1-026	HARDWIRE SWITCH #1, ON/OFF LATCHING, 10 AMPS BATTERY POWER		
	4C2-026	HARDWIRE SWITCH #2, ON/OFF LATCHING, 10 AMPS BATTERY POWER		
	4C3-017	HARDWIRE SWITCH #3, ON/OFF LATCHING, 10 AMPS BATTERY POWER		
	4C4-017	HARDWIRE SWITCH #4, ON/OFF LATCHING, 10 AMPS BATTERY POWER		
	81Y-005	PRE-TRIP INSPECTION FEATURE FOR EXTERIOR LAMPS ONLY		
	264-030	(1) OVERHEAD MOUNTED LANYARD CONTROL FOR DRIVER AIR HORN		



Prepared for:
 Martin Montalvo
 WILSONVILLE CITY OF
 29799 SW town Center Loop
 Wilsonville, OR 97070
 Phone: 503-570-1560

Prepared by:
 Dylan Dripps
 PREMIER TRUCK GROUP OF
 PORTLAND
 9622 N.E. VANCOUVER WAY
 PORTLAND, OR 97211
 Phone: 503-283-0345

Data Code	Description	Weight Front	Weight Rear
482-001	BW TRACTOR PROTECTION VALVE		
883-001	TRAILER HAND CONTROL BRAKE VALVE		
836-015	DIGITAL VOLTAGE DISPLAY INTEGRAL WITH DRIVER DISPLAY		
660-008	SINGLE ELECTRIC WINDSHIELD WIPER MOTOR WITH DELAY		
304-030	ROTARY HEADLAMP SWITCH, MARKER LIGHTS/HEADLIGHTS SWITCH WITH PULL OUT FOR OPTIONAL FOG/ROAD LAMPS		
882-004	TWO VALVE PARKING BRAKE SYSTEM WITH WARNING INDICATOR		
299-020	SELF CANCELING TURN SIGNAL SWITCH WITH DIMMER, HEADLAMP FLASH, WASH/WIPE/INTERMITTENT		
298-046	INTEGRAL ELECTRONIC TURN SIGNAL FLASHER WITH 40 AMP (20 AMP PER SIDE) TRAILER LAMP CAPACITY		

Design

065-000 PAINT: ONE SOLID COLOR

Color

980-5F6 CAB COLOR A: L0006EY WHITE ELITE EY
 986-020 BLACK, HIGH SOLIDS POLYURETHANE CHASSIS PAINT
 962-974 POWDER GRAY (N0020EA) FRONT WHEELS/RIMS (PKGGRY21, G, PG1)
 966-974 POWDER GRAY (N0020EA) REAR WHEELS/RIMS (PKGGRY21, G, PG1)
 964-6Z7 BUMPER PAINT: FP24812 ARGENT SILVER DUPONT FLEX
 969-998 NO CAB/BODY EXTERIOR DECALS
 963-003 STANDARD E COAT/UNDERCOATING

Certification / Compliance

996-001 U.S. FMVSS CERTIFICATION, EXCEPT SALES CABS AND GLIDER KITS

Sales Programs

NO SALES PROGRAMS HAVE BEEN SELECTED

TOTAL VEHICLE SUMMARY



Prepared for:
Martin Montalvo
WILSONVILLE CITY OF
29799 SW town Center Loop
Wilsonville, OR 97070
Phone: 503-570-1560

Prepared by:
Dylan Dripps
PREMIER TRUCK GROUP OF
PORTLAND
9622 N.E. VANCOUVER WAY
PORTLAND, OR 97211
Phone: 503-283-0345

Weight Summary

	Weight Front	Weight Rear	Total Weight
Factory Weight ⁺	7539 lbs	4870 lbs	12409 lbs
<hr/>			
Total Weight ⁺	7539 lbs	4870 lbs	12409 lbs

(+) Weights shown are estimates only.

If weight is critical, contact Customer Application Engineering.

(***) All cost increases for major components (Engines, Transmissions, Axles, Front and Rear Tires) and government mandated requirements, tariffs, and raw material surcharges will be passed through and added to factory invoices.



Prepared for:
 Martin Montalvo
 WILSONVILLE CITY OF
 29799 SW town Center Loop
 Wilsonville, OR 97070
 Phone: 503-570-1560

Prepared by:
 Dylan Dripps
 PREMIER TRUCK GROUP OF
 PORTLAND
 9622 N.E. VANCOUVER WAY
 PORTLAND, OR 97211
 Phone: 503-283-0345

D I M E N S I O N S

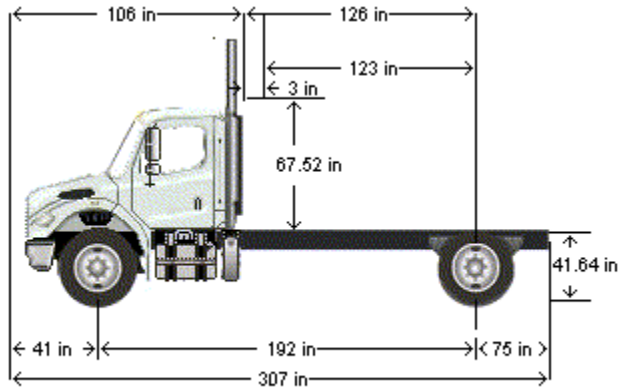

VEHICLE SPECIFICATIONS SUMMARY - DIMENSIONS

Model	M2106
Wheelbase (545)	4875MM (192 INCH) WHEELBASE
Rear Frame Overhang (552)	1900MM (75 INCH) REAR FRAME OVERHANG
Fifth Wheel (578)	NO FIFTH WHEEL
Mounting Location (577)	NO FIFTH WHEEL LOCATION
Maximum Forward Position (in)	0
Maximum Rearward Position (in)	0
Amount of Slide Travel (in)	0
Slide Increment (in)	0
Desired Slide Position (in)	0.0
Cab Size (829)	106 INCH BBC FLAT ROOF ALUMINUM CONVENTIONAL CAB
Sleeper (682)	NO SLEEPER BOX/SLEEPER CAB
Exhaust System (016)	RH OUTBOARD UNDER STEP MOUNTED HORIZONTAL AFTERTREATMENT SYSTEM ASSEMBLY WITH RH B-PILLAR MOUNTED VERTICAL TAILPIPE

TABLE SUMMARY - DIMENSIONS



Prepared for:
 Martin Montalvo
 WILSONVILLE CITY OF
 29799 SW town Center Loop
 Wilsonville, OR 97070
 Phone: 503-570-1560

Prepared by:
 Dylan Dripps
 PREMIER TRUCK GROUP OF
 PORTLAND
 9622 N.E. VANCOUVER WAY
 PORTLAND, OR 97211
 Phone: 503-283-0345

Dimensions	Inches
Bumper to Back of Cab (BBC)	106.3
Bumper to Centerline of Front Axle (BA)	40.7
Front Axle to Back of Cab (AC)	65.6
Min. Cab to Body Clearance (CB)	3.0
Back of Cab to Centerline of Rear Axle(s) (CA)	126.4
Effective Back of Cab to Centerline of Rear Axle(s) (Effective CA)	123.4
Back of Cab Protrusions (Exhaust/Intake) (CP)	2.0
Back of Cab Protrusions (Side Extenders/Trim Tab) (CP)	0.0
Back of Cab Protrusions (CNG Tank)	0.0
Back of Cab Clearance (CL)	3.0
Back of Cab to End of Frame	201.2
Cab Height (CH)	67.5
Wheelbase (WB)	191.9
Frame Overhang (OH)	74.8
Overall Frame Length	305.7
Overall Length (OAL)	307.5
Rear Axle Spacing	0.0
Unladen Frame Height at Centerline of Rear Axle	41.6

Performance calculations are estimates only. If performance calculations are critical, please contact Customer Application Engineering.



Prepared for:
 Martin Montalvo
 WILSONVILLE CITY OF
 29799 SW town Center Loop
 Wilsonville, OR 97070
 Phone: 503-570-1560

Prepared by:
 Dylan Dripps
 PREMIER TRUCK GROUP OF
 PORTLAND
 9622 N.E. VANCOUVER WAY
 PORTLAND, OR 97211
 Phone: 503-283-0345

TRUCK WEIGHT

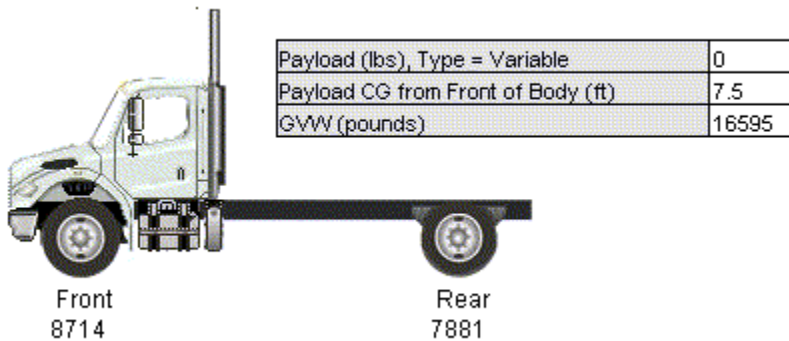

VEHICLE SPECIFICATIONS SUMMARY - TRUCK WEIGHT

Model	M2106
Cab Size (829).....	106 INCH BBC FLAT ROOF ALUMINUM CONVENTIONAL CAB
Expected Front Axle(s) Load (lbs).....	12000.0
Expected Pusher Axle(s) Load (lbs).....	0.0
Expected Rear Axle(s) Load (lbs).....	30000.0
Expected Tag Axle(s) Load (lbs).....	0.0
Expected GVW (lbs)	42000
Expected GCW (lbs).....	80000.0
Wheelbase (545)	4875MM (192 INCH) WHEELBASE
Pusher / Tag Axle (443).....	NO PUSHER OR TAG AXLE
Front Axle to Back of Cab (in).....	65.551
Cab to Body Clearance (in).....	3.0
Front Axle to Body (in).....	68.551
Truck Configuration (AA3)	TANK BODY
Body Length (ft)	15.0
Body Weight (lbs)	3200.0
Body Horiz CG from Body Front (ft)	7.5
Body Front to Rear Axle(s) CL (ft).....	10.28
Driver Weight (lbs).....	500.0
Driver Horizontal CG from Front Axle (in).....	46.302
Left-Hand Primary Fuel/Hydraulic Tank (204).....	60 GALLON/227 LITER RECTANGULAR ALUMINUM FUEL TANK - LH
Left Fuel Tank Horizontal CG (in).....	93.5435
Right-Hand Primary Fuel/Hydraulic Tank (206).....	NO RH FUEL TANK



Prepared for:
 Martin Montalvo
 WILSONVILLE CITY OF
 29799 SW town Center Loop
 Wilsonville, OR 97070
 Phone: 503-570-1560

Prepared by:
 Dylan Dripps
 PREMIER TRUCK GROUP OF
 PORTLAND
 9622 N.E. VANCOUVER WAY
 PORTLAND, OR 97211
 Phone: 503-283-0345

Right Fuel Tank Horizontal CG (in)0

TABLE SUMMARY - TRUCK WEIGHT

Item	Front(s)	Rear(s)	Total
Chassis Tare	7539	4870	12409
Fuel / Oil	239	247	486
Driver	379	121	500
Dealer Installed Options	0	0	0
Accessories Total	0	0	0
Body Tare	557	2643	3200
Truck Tare Weight	8714	7881	16595
Payload Total	0	0	0
Calculated Axle Loads	8714	7881	16595
Expected Axle Loads / GVW	12000	30000	80000
GAWR / GVWR	12000	24020	36020
Payload CG From Front of Body		7.5 feet	
Payload CG From Front Axle		13.2 feet	
Payload Distribution		Variable	
All weights displayed in pounds			

Item	Front(s)	Rear(s)	Total
Chassis Tare	7539	4870	12409
Fuel / Oil	239	247	486
Driver	379	121	500
Dealer Installed Options	0	0	0
Accessories Total	0	0	0
Body Tare	557	2643	3200
Truck Tare Weight	8714	7881	16595
Payload Total	0	0	0
Calculated Axle Loads	8714	7881	16595
Expected Axle Loads / GVW	12000	30000	80000
GAWR / GVWR	12000	24020	36020
Payload CG From Front of Body		7.5 feet	
Payload CG From Front Axle		13.2 feet	
Payload Distribution		Variable	
All weights displayed in pounds			



Prepared for:
Martin Montalvo
WILSONVILLE CITY OF
29799 SW town Center Loop
Wilsonville, OR 97070
Phone: 503-570-1560

Prepared by:
Dylan Dripps
PREMIER TRUCK GROUP OF
PORTLAND
9622 N.E. VANCOUVER WAY
PORTLAND, OR 97211
Phone: 503-283-0345

Performance calculations are estimates only. If performance calculations are critical, please contact Customer Application Engineering.



EXHIBIT B-1

LIMITED WARRANTY

Limited Warranty: Each machine manufactured by Thermo-Lay Manufacturing (or “the Company”) is warranted against defects in material and workmanship for a period of twelve (12) months, provided the machine is used in a normal and reasonable manner and in accordance with all operating instructions. In addition, certain machines and components of certain machines have extended warranties as set forth below. If sold to an end user for rental purposes, the applicable warranty period commences from the date of delivery to the end user. If used for rental purposes, the applicable warranty period commences from the date the machine is first made available for rental by the Company or its representative. The limited warranty may be enforced by any subsequent transferee during the warranty period. This limited warranty is the sole and exclusive warranty given by the Company.

Exclusive Remedy: Should any warranted product fail during the warranty period, the Company will cause to be repaired or replaced, as the Company may elect, any part or parts of such machine that the Company’s examination discloses to be defective in material or factory workmanship. Repairs or replacements are to be made at the selling Thermo-Lay Manufacturing distributor’s location or at other locations approved by the Company. In lieu of repair or replacement, the Company may elect, at its sole discretion, to refund the purchase price of any product deemed defective. The foregoing remedies shall be sole and exclusive remedies of any party making a valid warranty claim.

This Limited Warranty shall not apply to (and the Company shall not be responsible for):

1. Major components or trade accessories that have a separate warranty from their original manufacturer, such as, but not limited to, trucks, engines, hydraulic pumps and motors, tires, and batteries.
2. Normal adjustments and maintenance services.
3. Normal wear parts such as, but not limited to, oils, fluids, light bulbs, fuses, and gaskets.
4. Failures resulting from the machine being operated in a manner or for a purpose not recommended by the Company.
5. Repairs, modification, or alternations without express written consent of the Company, which in the Company’s sole judgment, have adversely affected the machine’s stability, operation or reliability as originally designed and manufactured.
6. Items subject to misuse, negligence, accident, or improper maintenance.

NOTE The use in the product of any part other than parts approved by the Company may invalidate this warranty. The Company reserves the right to determine, in its sole discretion, if the use of non-approved parts operates to invalidate the warranty. Nothing contained in this warranty shall make the Company liable for loss, injury, or damage of any kind to any person or entity resulting from any defect or failure of the machine.

THIS WARRANTY SHALL BE IN LIEU OF ALL OTHER WARRANTIES, EXPRESSED, OR IMPLIED. INCLUDING WITHOUT LIMITATION, ANY IMPLIED WARRANTIES OF MERCHANTABILITY OR FITNESS FOR A PARTICULAR PURPOSE, ALL OF WHICH ARE DISCLAIMED.

This warranty is in lieu of all other obligations or liabilities, contractual and otherwise, on the part of the Company. For the avoidance of doubt, the Company shall not be liable for any indirect, special, incidental, or consequential damages, including but not limited to, loss of use or lost profits. The Company makes no representation that the machine has the capacity to perform any functions other than as contained in the Company’s literature, catalogs or specifications accompanying delivery of the machine. No person or affiliated company representative is authorized to alter the terms of this warranty, to give any other warranties or to assure any other liability on behalf of the Company in connection with the sales, servicing or repair of any machine manufactured by the Company. Any legal action based hereon must be commenced within twelve (12) months of the event or facts giving rise to such action.

The Company reserves the right to make design changes or improvements to its products without imposing any obligation upon itself to change or improve previously manufactured products.



Thermo-Lay Manufacturing
1953 E. Commercial Street, Meridian, ID 83642
406-259-9525
www.thermo-lay.com | info@thermo-lay.com

WARRANTY

The warranty administrator at Thermo-Lay Manufacturing may be reached in the following ways:

Telephone: 406-259-9525
Email: Parts@Thermo-Lay.com
Email: Info@Thermo-Lay.com

Thermo-Lay Manufacturing
Attn: Warranty Department
1953 E. Commercial Street
Meridian, ID 83642

Parts requested under the warranty will be shipped with the understanding that the defective or filed parts are to be returned to Thermo-Lay within thirty (30) days. When parts are requested, the Warranty Department will require the equipment's serial number and a brief description of the failure or defect. The equipment's serial number and a brief description of the failure or defect **MUST** accompany any part being returned to the factory for warranty.

Parts must be returned and received by Thermo-Lay within thirty (30) days of the initiation date. Parts not returned within thirty (30) days will result in a rejection of the claim and the replacement parts shipped will be due and payable.

The shipment must be freight pre-paid to:

Thermo-Lay Manufacturing
1953 E. Commercial Street
Meridian, ID 83642

Return C.O.D. shipments will not be accepted. Return freight for approved claims will be reimbursed.

If Thermo-Lay determines that the parts do not need to be returned for warranty processing, the dealer/customer will be notified by email by Thermo-Lay.

Upon receipt of the part(s) Thermo-Lay will inspect the parts to make a determination of warranty. Thermo-Lay will notify the dealer/customer within sixty (60) days of the initiation date of the warranty.

NOTE: Failure to return the requested parts within the set time frame will void the warranty claim.

EXCLUSIONS AND LIMITATIONS

The warranty labor repair time allowances are based on actual or replacement times only. Warranty repairs are to be performed only at the authorized distributor's location or a facility approved by Thermo-Lay. If a warranty repair is to be completed by someone other than the authorized Thermo-Lay distributor, pre-approval must be obtained. If approval is granted, the warranty claim must clearly indicate who did the work, and a copy of their invoice must be attached electronically to the claim. Any third-party contractor will be allowed only the Standard Repair Time that would have been allowed the dealer. Travel time will be paid for actual time, up to a maximum of three (3) hours per claim. Travel hours will be reimbursed at ½ the warranty labor rate established for the dealer. There are no allowances made for the following costs or any similar field service expenses:

EXCLUSIONS AND LIMITATIONS

- Mileage
- Towing or hauling
- Fuel
- Phone calls
- Normal maintenance service
- Repairs due to initial faulty repair
- Road test of machine
- Diagnostic time, except when pre-approved for a qualified operation
- Dealer freight transfers between locations. The warranty does not apply to the following or any similar failures or costs unless it is the result of being directly damaged by the warrantable failure of a covered component.
- Failures caused by neglect, abuse, accident, misapplication, alterations to the machine after leaving the factory, failures caused by non-Thermo-Lay parts or acts of vandalism.
- Administrative fees
- Lodging
- Air freight
- Normal wear items
- Inspection services
- Oils, fluids, and filters
- Pre-delivery service and checks
- Routine adjustments
- Testing of repairs

WARRANTY REIMBURSEMENT WILL BE ISSUED AS A CREDIT TO THE DEALER/CUSTOMERS ACCOUNT.



Thermo-Lay Manufacturing
1953 E. Commercial Street, Meridian, ID 83642
406-259-9525
www.thermo-lay.com | info@thermo-lay.com

Time and Distance Tables

1.1 Freightliner Level II (Factory Released On or After 01/07/2013)

<i>Level II coverage is not available for vehicles in this vocation:</i>		<i>Mining</i>
Category Determinants		
Road Surface - most severe in-transit between sites	Up to 30% off-highway rough, maintained concrete/asphalt; maintained gravel/crushed rock; maintained dirt or soft soil	
	Models with limitations: Columbia, Century, or Coronado - Up to 10% off-highway rough, maintained concrete/asphalt; maintained gravel/crushed rock	
Gross Combined Weight Rating	140,000 lb/63 505 kg or less -Doubles on NY turnpikes are rated 143,000 lb -Doubles on FL turnpikes are rated 147,000 lb	
Axles and Manufacturer's Gross Vehicle Weight Rating		
2-Axle Unit	49,000 lb/21 000 kg or less	
3-Axle Unit	69,000 lb/31 000 kg or less	
4-Axle Unit	89,000 lb/40 000 kg or less	
5-Axles or More	98,000 lb/44 452 kg or less	
Coverage ¹		
Description	Time ²	Distance ²
Basic Vehicle	1 Year	100,000 mi/161 000 km
Battery	1 Year	100,000 mi/161 000 km
Brightwork	6 Months	Unlimited
Cab Corrosion/Perforation	5 Years	Unlimited
Cab Structure	3 Years	150,000 mi/241 000 km
Corrosion	6 Months	Unlimited
Crossmembers	5 Years	300,000 mi/483 000 km
Detroit Assurance ³	3 Years	300,000 mi/483 000 km
Emission Regulations ⁴		
Diesel Emission 2010 ⁵	5 Years	100,000 mi/161 000 km
GHG21 ⁶ (Medium Heavy Duty to Heavy Heavy Duty Trucks/Tractors)	5 Years	100,000 mi/161 000 km
GHG21 ⁶ Tire (File Direct)	2 Years	24,000 mi/38 400 km
Frame Rails	5 Years	300,000 mi/483 000 km
Front/Steer Axle ⁷		
Detroit ⁸	2 Years	Unlimited
Non-Detroit	2 Years	100,000 mi/161 000 km
Paint	1 Year	100,000 mi/161 000 km
Paint, Chassis	6 Months	Unlimited
Rear Axle ⁹		
Detroit ⁸	2 Years	Unlimited
Non-Detroit	2 Years	100,000 mi/161 000 km
Transfer Case	2 Years	100,000 mi/161 000 km

DISCLAIMER: Failure to read or distribute this information does not provide exemption from compliance with the information contained herein. Specifications are subject to change without notice. Intended for general information only, not offered as customer's Warranty.

Coverage ¹		
Description	Time ²	Distance ²
Transmission ¹⁰		
Detroit DT-12 ⁸	5 Years	750,000 mi/1 200 000 km
Non-Detroit	2 Years	100,000 mi/161 000 km

¹ Because Warranty coverage is determined by a unit's specifications, gross combination weight rating, road surface, and vocation, coverage may vary. For unit-specific coverage, Dealers should enter a product serial number or vehicle identification number on the *Coverage Info* screen in OWL; for customers without access to OWL, see ordering Dealer for more information.

² Time or distance, whichever comes first.

³ Coverage applies to vehicles spec'd with Detroit Assurance; this option is available on the Cascadia and New Cascadia.

⁴ See *Emission Regulations* subsection that follows or separate engine owner's manual for regulatory information.

⁵ Applies to vehicles equipped with EPA 2010 compliant diesel engines.

⁶ Applies to models 2013 and later domiciled in the United States and Canada.

⁷ Customers will have only one (1) type of front/steer axle coverage, either Detroit or non-Detroit, depending on how the unit is spec'd. Front axle coverage is also applicable to gliders. Detroit coverage may vary due to vocation, unit specifications, etc.; table shows the minimum coverage possible. For instructions on accessing unit-specific coverage, please see footnote 1 above.

⁸ Access Detroit parchments at *DTNACconnect > Warranty Lit > Coverages > Detroit*; for customers without access, see ordering Dealer for more information.

⁹ Customers will have only one (1) type of rear axle coverage, either Detroit or non-Detroit, depending on how the unit is spec'd. Detroit coverage may vary due to vocation, unit specifications, etc.; table shows the minimum coverage possible. For instructions on accessing unit-specific coverage, please see footnote 1 above.

¹⁰ Customers will have only one (1) type of transmission coverage, either Detroit or non-Detroit, depending on how the unit is spec'd.

DISCLAIMER: Failure to read or distribute this information does not provide exemption from compliance with the information contained herein. Specifications are subject to change without notice. Intended for general information only, not offered as customer's Warranty.

1.2 Freightliner Level II (Factory Released Prior to 01/07/2013)

<i>Level II coverage is not available for vehicles in this vocation:</i> Mining		
Category Determinants		
Road Surface - most severe in-transit between sites	Up to 30% off-highway rough, maintained concrete/asphalt; maintained gravel/crushed rock; maintained dirt or soft soil	
	Models with limitations: Columbia, Century, or Coronado - Up to 10% off-highway rough, maintained concrete/asphalt; maintained gravel/crushed rock	
Gross Combined Weight Rating	140,000 lb/63 505 kg or less -Doubles on NY turnpikes are rated 143,000 lb -Doubles on FL turnpikes are rated 147,000 lb	
Axles and Manufacturer's Gross Vehicle Weight Rating		
2-Axle Unit	46,000 lb/20 865 kg or less	
3-Axle Unit	66,000 lb/29 937 kg or less	
4-Axle Unit	86,000 lb/39 008 kg or less	
5-Axles or More	98,000 lb/44 452 kg or less	
Coverage ¹		
Description	Time ²	Distance ²
Basic Vehicle	1 Year	100,000 mi/161 000 km
Battery	1 Year	100,000 mi/161 000 km
Brightwork	6 Months	Unlimited
Cab Corrosion/Perforation	5 Years	Unlimited
Cab Structure	3 Years	150,000 mi/241 000 km
Corrosion	6 Months	Unlimited
Crossmembers	5 Years	300,000 mi/483 000 km
Emission Regulations ³		
Diesel Emission 2010 ⁴	5 Years	100,000 mi/161 000 km
GHG14/17 ⁵ (Medium Heavy Duty to Heavy Heavy Duty Trucks/Tractors)	5 Years	100,000 mi/161 000 km
GHG14/17 ⁵ Tire (File Direct)	2 Years	24,000 mi/38 400 km
Frame Rails	5 Years	300,000 mi/483 000 km
Front/Steer Axle ⁶		
Detroit ⁷	2 Years	Unlimited
Non-Detroit	2 Years	100,000 mi/161 000 km
Paint	1 Year	100,000 mi/161 000 km
Paint, Chassis	6 Months	Unlimited
Rear Axle ⁸		
Detroit ⁷	2 Years	Unlimited
Non-Detroit	2 Years	100,000 mi/161 000 km
Transfer Case	2 Years	100,000 mi/161 000 km

DISCLAIMER: Failure to read or distribute this information does not provide exemption from compliance with the information contained herein. Specifications are subject to change without notice. Intended for general information only, not offered as customer's Warranty.

Coverage ¹		
Description	Time ²	Distance ²
Transmission ⁹		
Detroit DT-12 ⁷	5 Years	750,000 mi/1 200 000 km
Non-Detroit	2 Years	100,000 mi/161 000 km

¹ Because Warranty coverage is determined by a unit's specifications, gross combination weight rating, road surface, and vocation, coverage may vary. For unit-specific coverage, Dealers should enter a product serial number or vehicle identification number on the *Coverage Info* screen in OWL; for customers without access to OWL, see ordering Dealer for more information.

² Time or distance, whichever comes first.

³ See *Emission Regulations* subsection that follows or separate engine owner's manual for regulatory information.

⁴ Applies to vehicles equipped with EPA 2010 compliant diesel engines.

⁵ Applies to models 2013 and later domiciled in the United States and Canada.

⁶ Customers will have only one (1) type of front/steer axle coverage, either Detroit or non-Detroit, depending on how the unit is spec'd. Front axle coverage is also applicable to gliders. Detroit coverage may vary due to vocation, unit specifications, etc.; table shows the minimum coverage possible. For instructions on accessing unit-specific coverage, please see footnote 1 above.

⁷ Access Detroit parchments at *DTNACconnect > Warranty Lit > Coverages > Detroit*; for customers without access, see ordering Dealer for more information.

⁸ Customers will have only one (1) type of rear axle coverage, either Detroit or non-Detroit, depending on how the unit is spec'd. Detroit coverage may vary due to vocation, unit specifications, etc.; table shows the minimum coverage possible. For instructions on accessing unit-specific coverage, please see footnote 1 above.

⁹ Customers will have only one (1) type of transmission coverage, either Detroit or non-Detroit, depending on how the unit is spec'd.

DISCLAIMER: Failure to read or distribute this information does not provide exemption from compliance with the information contained herein. Specifications are subject to change without notice. Intended for general information only, not offered as customer's Warranty.

Coverage Descriptions

Based on a unit's specifications, New Product Limited Warranty (Warranty) coverage applies. For unit-specific coverage information (time/distance amounts and component descriptions), enter a product serial number or vehicle identification number (VIN) on the *Check Info/Check Coverage* screen in Online Warranty Link (OWL). Use time and distance tables in conjunction with the coverage description paragraphs; if a coverage is applicable, it will be included as a row in the table.

2.1 Axles

Front/Steer Axle

Detroit

A steer axle is non-powered. Coverage includes all axle components supplied/manufactured by Detroit Diesel Corporation (Detroit). Warrantable components could include, but not be limited to, I-beam, steering knuckles, spindles, kingpins, kingpin bearings, and steering arms. Tie rod assembly and boots may have a different coverage period; see specific coverage row. *Excluded components could include, but not be limited to, wheel end equipment and steering linkage components.*

Non-Detroit

A front/steer axle can be a front powered or non-powered axle. Coverage applies to factory-installed axles and includes I-beam, steering knuckles, differential on drive steer axle, spindles, kingpins, kingpin bearings, and steering arms. *Excludes wheel end equipment, tie rod ends, steering linkage components, driveline(s), U-joints, kingpin bushings, kingpin seals, tag axle(s), pusher axle(s), and any axle installed by a service location or body builder.*

Pusher Axle

A pusher axle is a non-driven, weight-bearing axle that can be raised when not required to bear a portion of the load. Since the pusher axle can be of many different configurations, Warranty coverage applies to factory-installed axles and includes all components included in the individual build specification of each individual application. *Excludes any axle installed by a service location or body builder.*

Rear/Drive Axle

Detroit

A rear drive axle can be a single or tandem axle configuration. Coverage includes all axle components supplied/manufactured by Detroit. Warrantable components could include, but not be limited to, axle housing, carrier assembly, differential assembly, power divider, and axle shafts. Seals and gaskets may have a different coverage period; see specific coverage row. *Excluded components could include, but not be limited to, suspension and torque rod brackets, wheel end equipment, wiring, yokes, and attaching hardware.*

DISCLAIMER: Failure to read or distribute this information does not provide exemption from compliance with the information contained herein. Specifications are subject to change without notice.

Non-Detroit

A rear axle could be a drive, non-drive, or tandem axle. Coverage applies to factory-installed axles and includes axle housing, carrier assembly, differential assembly, power divider, axle shafts, and gaskets and seals. *Excludes suspension and torque rod brackets, tie rod ends, wheel end equipment, wiring, yokes, driveline(s), U-joints, attaching hardware, tag axle(s), pusher axle(s), and any axle installed by a service location or body builder.*

Tag Axle

A tag axle is a non-driven, continuous weight-bearing axle. Since the tag axle can be of many different configurations, Warranty coverage applies to factory-installed axles and includes all components included in the individual build specification of each individual application. *Excludes any axle installed by a service location or body builder.*

2.2 Basic Chassis/Vehicle

Note: Basic Chassis applies to Freightliner Custom Chassis Corporation (FCCC) products; Basic Vehicle applies to Freightliner, Western Star, and Thomas Built Buses (TBB) products.

Coverage includes all factory-installed components of the chassis/vehicle that are not excluded elsewhere in the Warranty or described as having a different time, or distance, or hours, or listed separately on each new vehicle coverage table. See the Warranty Manual for a complete list of exceptions and exclusions. Also excluded are components warranted directly by component manufacturer.

2.3 Batteries

*Detroit brand batteries of the same group and amperage are interchangeable with Alliance brand batteries and carry the same coverage period.

Standard Battery

Coverage includes Alliance,* EnerSys (NorthStar, Odyssey), and DTNA Genuine brand batteries only; claims for all other brands must be submitted directly to the supplier. Includes starting battery assemblies and factory-installed auxiliary power unit (APU) battery assemblies. *Excludes non-Alliance, non-EnerSys, and non-DTNA Genuine brand batteries, battery cables, battery mounting box, and hardware.*

Cranking Battery Only

Coverage includes Alliance,* EnerSys (NorthStar, Odyssey), and DTNA Genuine brand batteries only; claims for all other brands must be submitted directly to the supplier. Cranking battery warranty includes factory-installed cranking (starter) battery assemblies only. *Excludes APU battery assemblies, non-Alliance, non-EnerSys, and non-DTNA Genuine brand batteries, battery cables, battery mounting box, and hardware.*

Auxiliary Battery Only

Coverage includes Alliance,* EnerSys (NorthStar, Odyssey), and DTNA Genuine brand batteries only; claims for all other brands must be submitted directly to the supplier. Auxiliary battery warranty includes factory-installed APU battery assemblies only. *Excludes cranking (starter) battery assemblies, non-Alliance, non-EnerSys, and non-DTNA Genuine brand batteries, battery cables, battery mounting box, and hardware.*

DISCLAIMER: Failure to read or distribute this information does not provide exemption from compliance with the information contained herein. Specifications are subject to change without notice.

2.4 Brightwork

Coverage includes all factory-installed components with chrome, polished aluminum, or polished stainless steel surfaces. *Excludes any damage to backside of bumpers, and concealed or inner surfaces.*

2.5 Cab Corrosion/Perforation

Coverage is limited to rust-through or perforation of the cab and integral sleeper structure and sleeper box due to corrosion from within. *Excludes all conditions of rust or corrosion that have not resulted in rust-through or perforation as well as surface rust or corrosion caused by non-adhesion and any damage to paint such as chips or scratches.*

2.6 Cab Structure

Coverage includes cab and integral sleeper structural components, structural components of factory-installed sleeper boxes, sheet metal panels, doors, and hoods. *Excludes all bolt-on components including door and hood hinges, latches, guides, and other mounting hardware.*

2.7 Corrosion

Coverage includes Warranty against corrosion to any metal or metal alloy part of the vehicle.

Excludes:

- Corrosion caused by general rust (e.g., rust on the unfinished backside of a bumper)
- Surface rust caused by chips or scratches in the paint or chrome surfaces
- Corrosion caused by severe wash solutions, cleaning solvents, detergents, compounds
- Corrosion caused by salinity in the environment or corrosive salts and/or chemicals used on the road surface
- Corrosion due to improper use, misuse, or abuse, negligence, including improper or insufficient maintenance
- Corrosion due to ocean spray
- Corrosion due to environmental damage, including airborne fallout (includes chemicals, tree sap, etc.), or other atmospheric conditions, or other acts of nature
- Corrosion due to damage caused by high-pressure washing
- Corrosion caused by acid rain or other industrial fallout
- Corrosion due to improper prevention measures during storage or use
- Corrosion or rust on tone rings, rotors, or drums

2.8 Cowl Corrosion

Coverage is limited to rust-through or perforation of the cowl due to corrosion from within. *Excludes all conditions of rust or corrosion that have not resulted in rust-through or perforation as well as surface rust or corrosion caused by non-adhesion and any damage to the paint such as chips or scratches.*

DISCLAIMER: Failure to read or distribute this information does not provide exemption from compliance with the information contained herein. Specifications are subject to change without notice.

2.9 Cowl Structure

Coverage includes cowl structural components, sheet metal panels, and hood. *Excludes all bolt-on components (e.g., hood hinges, latches, guides, or other mounting hardware).*

2.10 Crossmembers

Coverage includes crossmembers, gussets, and huck-mounting bolts that attach gussets to crossmembers and gussets/crossmembers to frame rails. *Excludes any bolt-on item attached with either conventional or huck bolts.*

2.11 Driveline

Coverage includes driveshaft tubing, U-joints, yokes, support bearings, and splines.

2.12 Frame Rails

Coverage is limited to breaking or cracking of factory-installed frame rails, frame rail liners, frame rail extensions, and any item(s) factory welded to them. *Excludes all bolt-on items attached with either conventional or huck bolts.*

2.13 Glider

A glider is a vehicle that may be ordered without major components. Coverage includes all components identified on the build specification.

2.14 Hybrid Transmission - Eaton

Eaton requires that only hybrid-authorized dealerships work on units equipped with Eaton hybrid parts. Pre-authorization is required prior to repair of these vehicles in order to obtain technical assistance and a pre-authorization number for replacement parts. Eaton hybrid parts will be shipped directly from Eaton and will not be stocked in the Parts Distribution Centers (PDCs) due to the short shelf life and low volume. The following hybrid parts are covered under this Warranty: power electronics carrier (PEC), motor generator, inverter, AC/DC converter, hybrid control module (HCM), transmission control module (TCM), clutch, and electronic clutch actuator (ECA). Coverage does NOT include oil cooler or cooling systems. Please refer to Roadranger Warranty Guide TCWY0900 for more information on complete listing of limits and exclusions, as well as terms and conditions.

2.15 Paint (Body, Cab, Cowl)

Body Paint

Coverage includes all factory-painted exterior body surfaces and defects such as orange peel, peeling/delaminating, cracking/checking, or loss of gloss due to cracking, checking, or hazing. *Excludes lack of gloss issues on vehicles painted with low gloss colors; the undersides of hoods and roofs and side mounted air fairings; and any damages to the paint or painted surface such as chips and scratches.*

DISCLAIMER: Failure to read or distribute this information does not provide exemption from compliance with the information contained herein. Specifications are subject to change without notice.

Cab Paint

Coverage includes all factory-painted surfaces (except those included in chassis paint coverage) and defects such as orange peel, peeling/delaminating, cracking/checking, or loss of gloss due to cracking, checking, or hazing. *Excludes lack of gloss issues on vehicles painted with low gloss colors; the undersides of hoods and roofs and side mounted air fairings; and any damages to the paint or painted surface such as chips and scratches.*

Cowl Paint

Coverage includes all factory-painted exterior surfaces of cowl structure (except those included in chassis paint coverage) and defects such as orange peel, peeling/delaminating, cracking/checking, or loss of gloss due to cracking, checking, or hazing. *Excludes lack of gloss issues on vehicles painted with low gloss colors; the undersides of hoods and roofs and side mounted air fairings; and any damages to the paint or painted surface such as chips and scratches.*

2.16 Paint (Chassis)

Coverage includes all factory-painted surfaces on frame rails, crossmembers/gussets, front and rear bumpers, suspension components, powertrain components, drivelines, fuel tanks, air tanks, wheel end equipment, tool boxes, battery boxes, access steps, attaching brackets and hardware, and defects such as peeling or non-adhesion. *Excludes U-joints and any damages to paint or painted surface such as chips and scratches.*

2.17 Towing/Roadside Assistance

Coverage may include emergency roadside assistance or towing to the nearest Authorized Service Facility for a warrantable repair in a vehicle-down situation that prevents the safe and lawful operation of the vehicle. Verify coverage on the *Coverage Information* screen in OWL; coverage will display as a separate category. If the customer requests towing to a location beyond the distance to the nearest Authorized Service Location, the customer will be responsible for the additional charges.

2.18 Transfer Case

Coverage includes housing and all internally lubricated parts. *Excludes broken synchronizer pins, power take-offs (PTOs), airlines, gauge, clutch assemblies, driveline(s), and U-joints.*

2.19 Transmission

Detroit

Coverage includes all transmission components supplied/manufactured by Detroit. *Excludes maintenance items.*

DISCLAIMER: Failure to read or distribute this information does not provide exemption from compliance with the information contained herein. Specifications are subject to change without notice.

Non-Detroit

Coverage does not include Allison transmissions or Eaton Hybrid transmissions. Coverage includes housing and all internally lubricated parts, electric/air shift/control units, valves, gaskets, and seals. *Excludes broken synchronizer pins, PTOs, airlines, gauge, clutch assemblies, driveline(s), and U-joints.*

DISCLAIMER: Failure to read or distribute this information does not provide exemption from compliance with the information contained herein. Specifications are subject to change without notice.

New Product Limited Warranty Statements

The following section outlines standard Limited Warranty (Warranty) statements for all new Daimler Trucks North America LLC (DTNA; Company) products sold by DTNA and domiciled in the USA (50 states and Washington, D.C.) and Canada. As necessary, information below may be divided by DTNA product type (vehicle/axle); this information is also included in the applicable Owner's Warranty Information Booklet.

Based on a product's specifications, Warranty coverage varies. For product-specific coverage information (time/distance amounts and component descriptions), enter a product serial number or vehicle identification number (VIN) on the *Coverage Information* screen in the OWL. General time/distance amounts and coverage descriptions are available by DTNA brand at *DTNAConnect > Warranty Lit > Other Warranty Documents > Coverages*.

3.1 New Vehicle Limited Warranty Statement

Under this New Vehicle Limited Warranty, DTNA warrants that each new vehicle will be free from defects in material and workmanship that occur under normal use within the applicable Warranty period, subject to certain limitations and exclusions as specified in this document.

This Limited Warranty applies only to new vehicles sold by an Authorized DTNA Service Location or ordered directly from DTNA; vehicles sold at auction or as a result of repossession retain the Warranty coverage from the original in-service date or factory invoice date if the vehicle has not been warranty registered.

DTNA reserves the right to reduce or remove coverage on vehicles in salvage condition.

This Warranty covers all components and parts unless specifically covered by other warranties or otherwise excluded by this document.

3.2 New Powertrain Component Statements

Engine components are covered by two types of warranties, the standard Limited Warranty and the Emission Control Systems Warranty, a requirement of the U.S. (Federal) Clean Air Act and Canada Motor Vehicle Safety Act. Axle and transmission components are covered by the standard Limited Warranty.

New Powertrain Component Limited Warranty

The New Product Limited Warranty covers product repairs to correct any malfunction occurring during the Warranty period resulting from defects in material or workmanship. This Limited Warranty applies to the first retail purchaser and subsequent retail owners during the applicable Warranty period of new powertrain components manufactured by Detroit Diesel and/or supplied by Detroit Diesel or Detroit Diesel of Canada Limited (all which are collectively referred to as Detroit), subject to certain limitations and exclusions as specified in this document.

The Warranty period begins on the date the product is delivered to the first retail purchaser or put in use prior to sale at retail, whichever occurs first, and ends at the specified time or distance limits.

The cost of service supplies which are not reusable due to needed repairs is covered by this Warranty. Reasonable towing costs to the nearest authorized service facility are covered when due to warrantable failure, the powertrain component is either inoperable, cannot be safely operated, or continued operation would cause further damage to the product. Detroit will pay reasonable travel expenses for the repairing mechanic to travel to and from the repair site.

DISCLAIMER: Failure to read or distribute this information does not provide exemption from compliance with the information contained herein. Specifications are subject to change without notice. Intended for general information only, not offered as customer's Warranty.

Engine Major Component Warranty Coverage

Engine major component warranty covers casting defects. Casted engine major components are: cylinder block/head, crankshaft, camshaft, main bearing bolts, flywheel housing, connecting rod assemblies, oil cooler housing, oil coolant module casting, water pump housing, and air inlet housing. Coverage is for the failed engine major component only; labor and additional parts are excluded. Progressive damage is limited to only the engine major component(s) affected by the failure.

Engines used in the on-highway application may carry longer coverage on engine major components; review the applicable Warranty parchment for coverage:

- MBE4000, Series 60, DD13, DD15, DD16 diesel fueled engines in on-highway applications (on-highway refers to a truck or coach designed and used to carry passengers and/or cargo, primarily on streets or paved highways)

Emission Control Systems Warranty

For detailed information about product compliance with U.S. and Canadian law regarding design, build, and equipment, see the [Emission Regulations \(Diesel Vehicles\)](#) section. Please note that emission-related components no longer covered under the Limited Warranty described above may still be covered under the Emission Control Systems Warranty.

Certified Engines and Engine Parts

The Warranty period shall begin on the date the vehicle is delivered to the first retail purchaser or, if the vehicle is first placed in service as a demonstrator prior to sale at retail, on the date the vehicle is first placed in such service. Emission related defects in the genuine Company components listed in the [Emission Regulations \(Diesel Vehicles\)](#) section, including reasonable related diagnostic costs, are covered by this Warranty.

Covered components and component terminology varies from engine to engine. Some scheduled maintenance is required (refer to the Owner's Emission Control Maintenance Service Chart which is included in the Warranty Information booklet). Please check the specific Warranty Information Booklet to determine which components are covered by the emissions control systems warranty.

Service Locations should refer to the applicable Engine Warranty Information booklet to determine if a particular component is covered by the Emission Control Systems Warranty, as the components covered differ on each engine type as well as from year to year.

3.3 Limitations

This Warranty does not apply to products that are sold or domiciled outside of the United States (50 states and Washington, D.C.) or Canada.

This Warranty does not apply to non-Detroit engines, Allison transmissions, tires, or other components or parts that are not manufactured by Company and that are warranted directly by their respective manufacturers. Progressive damage caused by these manufacturers' components to any other parts including, but not limited to, parts installed by Company is excluded from Company warranty coverage. With respect to the foregoing, Company makes no Warranty whether express, implied, statutory or otherwise including, but not limited to, parts installed by Company is excluded from Company Warranty coverage. With respect to the foregoing, Company makes no Warranty whether express, implied, statutory, or otherwise including, but not limited to, any Warranty of merchantability or fitness for a particular purpose.

DISCLAIMER: Failure to read or distribute this information does not provide exemption from compliance with the information contained herein. Specifications are subject to change without notice. Intended for general information only, not offered as customer's Warranty.

THIS WARRANTY IS EXCLUSIVE AND IN LIEU OF ALL OTHER WARRANTIES OF ANY KIND WHETHER WRITTEN, ORAL, OR IMPLIED INCLUDING, BUT NOT LIMITED TO ANY WARRANTY OF MERCHANTABILITY OR FITNESS FOR A PARTICULAR PURPOSE. THIS WARRANTY SPECIFICALLY EXCLUDES ANY OTHER WARRANTIES OR CONDITIONS PROVIDED FOR BY LAW, WHETHER STATUTORY OR OTHERWISE.

COMPANY'S SOLE OBLIGATION UNDER THIS WARRANTY SHALL BE TO REPAIR OR REPLACE, IN COMPANY'S SOLE DISCRETION, ANY DEFECTIVE COMPONENT OR PART. SUCH REPAIR OR REPLACEMENT SHALL BE WITHOUT COST TO PURCHASER WHEN PERFORMED WITHIN THE APPLICABLE WARRANTY PERIOD (TIME, DISTANCE, OR HOUR LIMIT, WHICHEVER OCCURS FIRST).

Purchaser must notify Company, within the applicable Warranty period, of any failure of the product to comply with this Warranty and Purchaser must, at Purchaser's expense, promptly return the unit to an Authorized Service Facility for inspection and repair or replacement of any defect in material or workmanship occurring within the applicable Warranty period. During New Product coverage, Warranty reimbursement will not be paid on repairs performed by customers on their own vehicles without a current Customer Performed Warranty Agreement (CPWA).

The product must be maintained and serviced according to the prescribed schedules outlined in the Driver's/ Operator's and Maintenance Manuals. Receipted bills and other evidence showing that required maintenance and service have been performed are required by Company as a condition of this Warranty.

After the Company's obligations under this Warranty expire, all liabilities of Company to Purchaser under this Warranty shall terminate. Repairs made under this Warranty do not constitute an extension of the original Warranty period for the vehicle or for any specific component or part.

To the extent that any provision of this Warranty contravenes the law of any jurisdiction, such provision shall be inapplicable in such jurisdiction, and the remainder of the Warranty shall not be affected.

3.4 Purchaser's Exclusive Remedy

THIS WARRANTY SHALL BE THE PURCHASER'S SOLE AND EXCLUSIVE REMEDY AGAINST COMPANY, WHETHER IN CONTRACT, UNDER STATUTE (INCLUDING STATUTORY PROVISIONS AS TO CONDITIONS AS TO QUALITY OR FITNESS FOR ANY PARTICULAR PURPOSE OF GOODS SUPPLIED PURSUANT TO THE CONTRACT OF SALE), WARRANTY, TORT, STRICT LIABILITY, OR ANY OTHER LEGAL THEORY.

3.5 Limitation of Liability

COMPANY'S LIABILITY UNDER THIS WARRANTY IS LIMITED TO THE COST TO REPAIR OR REPLACE, IN COMPANY'S SOLE DISCRETION, THE DEFECTIVE COMPONENT OR PART THAT IN NO EVENT SHALL EXCEED THE FAIR MARKET VALUE OF THE PRODUCT AT THE TIME THE DEFECT IS DISCOVERED.

IN NO EVENT SHALL COMPANY BE LIABLE FOR SPECIAL, INDIRECT, INCIDENTAL, OR CONSEQUENTIAL DAMAGES INCLUDING, BUT NOT LIMITED TO, INJURIES TO PERSONS OR DAMAGE TO PROPERTY, LOSS OF PROFITS OR ANTICIPATED PROFITS, OR LOSS OF PRODUCT USE.

3.6 Emission Regulations (Diesel Vehicles)

Vehicles and engines are designed, built, and equipped so as to conform, at the time of sale, with requirements of manufacturers whose vehicles and engines are designed to meet applicable Greenhouse Gas (GHG) and Fuel Efficiency Standards of the U.S. (Federal) Environmental Protection Agency (EPA), Emission Regulations under the Canada Motor Vehicle Safety Act in Canada, and the California Air Resources Board (CARB). Engines and vehicles are free from defects in material and workmanship which cause the engine or vehicle to fail to conform with

DISCLAIMER: Failure to read or distribute this information does not provide exemption from compliance with the information contained herein. Specifications are subject to change without notice. Intended for general information only, not offered as customer's Warranty.

those regulations for the Warranty period. The Warranty period is 100,000 miles or five (5) years of operation, whichever occurs first, or the New Product Warranty, if the product warranty is longer for all emission-related components except tires and 24,000 miles or two (2) years, whichever occurs first, for the tires.

The Warranty obligations are not dependent upon the use of any particular brand of replacement parts. The Owner may elect to use non-Genuine Company Parts for replacement purposes. Use of replacement parts which are not of equivalent quality may impair the effectiveness of emission control systems. If other than Genuine Company Parts are used for maintenance replacements or for the repair of components affecting emission controls, the Owner should assure himself/herself that such parts are warranted by their manufacturer to be equivalent to Genuine Company Parts in performance and durability.

Coverage exclusions are listed in *Coverage Exclusions* elsewhere in this section.

Warranted Components					
Unless otherwise noted, the Warranty period is 5 years/100,000 miles, whichever occurs first, or the New Product Warranty, if the product Warranty is longer for all emission-related components except tires.					
Diesel engines certified to California model year 2022 and later standards come with emission warranty periods of 5 years/150,000 miles if medium heavy duty and 5 years/350,000 miles if heavy heavy duty.					
Coverage is determined based on engine and vehicle emissions model year. To determine an engine’s emissions model year, refer to the EPA/CARB certification label on the engine. To determine the vehicle’s emissions model year, refer to the EPA/CARB certification label on the driver’s door or door jamb.					
Components ¹	Diesel Emission 2010		Gasoline Evaporative Emission 2011 ²	GHG21	
	Detroit Engine	DTNA Installed ³	DTNA Installed	Detroit Engine	DTNA Installed ⁴
A-Pillar Turning Vane					X
Aerodynamic Quarter Fenders					X
Aerodynamic Roof Fairings					X
Aerodynamic Roof Fairings (Adjustable Height)					X
Aerodynamic Side Fairings					X
Aerodynamic Wheel Covers					X
Aftertreatment System (ATS) Aftertreatment Control Module (ACM)	X			X	
Air Cleaner (Excludes Filter Element)			X		
Air Conditioning Component Leakage					X
Air Intake Pipes			X		
Air Intake Resonator			X		
Ambient Air Temperature (AAT) Sensor					X
ATS Aftertreatment Device (ATD) Wiring Harness	X			X	

DISCLAIMER: Failure to read or distribute this information does not provide exemption from compliance with the information contained herein. Specifications are subject to change without notice. Intended for general information only, not offered as customer’s Warranty.

Components ¹	Diesel Emission 2010		Gasoline Evaporative Emission 2011 ²	GHG21	
	Detroit Engine	DTNA Installed ³	DTNA Installed	Detroit Engine	DTNA Installed ⁴
ATS Diesel Exhaust Fluid (DEF) Coolant Supply Valve & DEF Coolant Lines		X			
ATS DEF Pump	X			X	
ATS DEF Fuel Rail Pressure Sensor	X			X	
ATS DEF Fuel Pressure Sensor (Low)	X			X	
ATS DEF Low Dosing Unit	X			X	
ATS DEF System Air Pressure Regulator & Associated Air Lines		X			
ATS DEF System Chassis Interface Harness		X			
ATS DEF Tank		X			
ATS DEF Tank DEF Level Gauge		X			
ATS DEF Tank DEF Temperature Sensor		X			
ATS DEF Tank Heater Tubing		X			
ATS DEF Temperature Sensor NOX Sensors	X			X	
ATS Diesel Oxidation Catalyst (DOC) Inlet Temperature Sensor	X			X	
ATS DOC Outlet Temperature Sensor	X			X	
ATS Diesel Particulate Filter (DPF) Inlet Pressure Sensor	X			X	
ATS DPF Outlet Pressure Sensor	X			X	
ATS DPF Outlet Temperature Sensor	X			X	
ATS Doser Block Assembly	X			X	
ATS Electrically-Heated DEF Lines		X			
ATS Fuel Doser Valve	X			X	
ATS Oxidation Catalyst	X			X	
ATS Particulate Filter	X			X	
ATS Selective Catalytic Reduction (SCR) Catalyst	X			X	
Automatic Engine Shutdown Timer - Sleep Cab Tractors: Includes Auxiliary Technologies (Battery or Diesel Auxiliary Power Unit, Fuel-Operated Heater, Engine Start-Stop)					X
Automatic Engine Shutdown Timer - Vocational					X
Automatic Tire Inflation System					X
Cam Sensor			X		

DISCLAIMER: Failure to read or distribute this information does not provide exemption from compliance with the information contained herein. Specifications are subject to change without notice. Intended for general information only, not offered as customer's Warranty.

Components ¹	Diesel Emission 2010		Gasoline Evaporative Emission 2011 ²	GHG21	
	Detroit Engine	DTNA Installed ³	DTNA Installed	Detroit Engine	DTNA Installed ⁴
Camshaft Position Sensor	X			X	
Catalytic Converter			X		
Charge Air Cooler		X			
Charge Air Cooler Outlet Sensor	X			X	
Chassis Fairing Skirts					X
Coolant Outlet Temperature Sensor	X			X	
Coolant Sensor			X		
Crank Sensor			X		
Crankshaft Position Sensor	X			X	
Data Link Connector		X	X		X
Delta P Sensor	X			X	
Drive Wheel Fairings					X
Engine Coolant Temp Sensor			X		
Engine Control Module (ECM)			X		
Engine Start/Stop System					X
Evap Canister & Evap Canister Vent Solenoid			X		
Exhaust Gas Piping from the Turbocharger out to the Last ATD		X			
Exhaust Gas Recirculation (EGR) Cooler	X			X	
EGR Valve & Actuator	X			X	
Exhaust Manifold & Exhaust Manifold Gaskets			X		
Exhaust Pipes (Between Exhaust Manifold & Catalyst)			X		
Fuel Injectors	X		X	X	
Fuel Lines			X		
Fuel Rail			X		
Fuel Tank			X		
Fuel Tank Fairings (Chassis Fairings)					X
Fuel Tank Pressure Sensor			X		
Fuel Temperature Sensor	X			X	
Gap Reducing Fairings					X

DISCLAIMER: Failure to read or distribute this information does not provide exemption from compliance with the information contained herein. Specifications are subject to change without notice. Intended for general information only, not offered as customer's Warranty.

Components ¹	Diesel Emission 2010		Gasoline Evaporative Emission 2011 ²	GHG21	
	Detroit Engine	DTNA Installed ³	DTNA Installed	Detroit Engine	DTNA Installed ⁴
Gas Cap			X		
High Pressure Fuel Pump	X			X	
Ignition Coils			X		
Intake Manifold Pressure Sensor	X			X	
Intake Manifold Temperature Sensor	X			X	
Intake Throttle Valve & Adaptor	X			X	
Knock Sensors			X		
Malfunction Indicator Lamp (MIL)		X	X		X
Manifold Absolute Pressure (MAP) Sensor			X		
Mass Air Flow Sensor			X		
Motor Control Module (MCM)	X			X	
Neutral at Stop - Allison Automatic Transmissions ⁵					X
Neutral Coast - Detroit eCoast, Cummins/Eaton Smart-Coast ⁵					X
Oxygen (O ₂) Sensors			X		
Oil Fill Cap			X		
Oil Temperature Sensor	X			X	
Positive Crankcase Ventilation (PCV) Hose (Engine to Air Intake Pipe)			X		
Predictive Cruise Control - Detroit Intelligent Powertrain Management (IPM), Cummins Predictive Cruise Control					X
Purge Control Valve			X		
Rear Axles ⁵					X
Roof Spoilers					X
Side Extenders					X
Spark Plugs ⁶			X		
Spark Plug Wires			X		
Temperature-Barometric Air Pressure Sensor					X
Throttle Body			X		
Throttle Pedal			X		

DISCLAIMER: Failure to read or distribute this information does not provide exemption from compliance with the information contained herein. Specifications are subject to change without notice. Intended for general information only, not offered as customer's Warranty.

Components ¹	Diesel Emission 2010		Gasoline Evaporative Emission 2011 ²	GHG21	
	Detroit Engine	DTNA Installed ³	DTNA Installed	Detroit Engine	DTNA Installed ⁴
Tire Pressure Monitoring System					X
Tires ⁷					X
Transmissions ⁵					X
Transmission Control Module			X		
Transmission Speed Sensor			X		
Turbo Speed Sensor	X			X	
Turbocharger	X			X	
Vapor Lines			X		
Vehicle Speed Limiter					X
Vehicle Speed Sensor (Transmission Main Shaft)		X			X
Wait to Start Indicator/Lamp					X

¹ Per California Emission Control Systems Warranty Statement, DTNA must warrant the emission control system components for the vehicle in accordance with either Diesel Emission 2010 or Gasoline Evaporative Emission 2011, whichever is applicable.

² Coverage period is 5 years/50,000 miles (80 500 km), whichever occurs first.

³ The following are excluded under Emissions coverage but are covered under standard New Vehicle Warranty coverage:

- ATS ACM Mounting Bracket and Protective Cover
- DEF Tank Mounting Brackets/Hardware
- DEF Pump Mounting and Protective Cover

⁴ Diesel Emission 2010 components and emission-related defects in the marked components listed are included in this coverage. Coverage duration:

- Spark-ignition engines and light heavy-duty vehicles – 5 years/50,000 miles (80 500 km), whichever occurs first
- Compression ignition engines and medium and heavy heavy-duty vehicles – 5 years/100,000 miles (161 000 km), whichever occurs first

⁵ To the extent warranted under component manufacturers' GHG21 emission-related warranty responsibilities, as detailed in warranty documentation.

⁶ Spark plugs are warranted under Basic Chassis coverage or until the first required maintenance, whichever comes first.

⁷ Coverage period is 2 years/24,000 miles, whichever occurs first. File claims directly to tire manufacturer.

3.7 Coverage Exclusions

The following components, parts, or conditions are specifically excluded from coverage under this Warranty.

Note: Parts found defective prior to installation must be filed as a Parts Adjustment Request (PAR) to the Parts Distribution Center (PDC).

Aerodynamic Wheel Covers

Aerodynamic wheel covers are excluded from coverage under Warranty.

Note: Mounting loose covers on Freightliner Cascadia trucks may be reimbursed; varies by model/specifications.

DISCLAIMER: Failure to read or distribute this information does not provide exemption from compliance with the information contained herein. Specifications are subject to change without notice. Intended for general information only, not offered as customer's Warranty.

Air Springs

Tolerance buildup can occur during the assembly process of the rear suspension and rear cab air springs, and can cause the springs to have the appearance of being crooked, misaligned, or improperly installed. This tolerance buildup is not detrimental to the operation of the vehicle and will not have an effect on either the quality of the ride or the durability of the components or vehicle. Straightening of these springs is not covered under Warranty.

Alignment of Axles/Wheels/Steering Wheel

Each DTNA vehicle manufacturing plant uses an integrated alignment system to align axles and wheels and to center the steering wheel to DTNA specifications. Realignment or readjustment of these items, including steering stops and steering poppets, is not covered under Warranty.

Any special alignment settings at the request of the Owner must be handled between the service location and Owner after delivery from factory. These special adjustments are not covered under Warranty.

Axle Breather Vents

During the manufacturing process, an oil run or drip stain may appear at the breather vent. Removing the vent, applying pipe sealant to the threaded vent fitting and re-installing the vent is unnecessary. Removing the axle breather vent and re-sealing the threaded fitting is not covered under this Warranty.

Cab Interior Components

The repair or replacement of cab interior components that are rendered unserviceable due to normal wear or abuse are not covered under this Warranty.

These components include, but are not limited to:

- Curtains
- Floor coverings (including floor mats)
- Painted trim components
- Steering wheel
- Steering wheel wrap
- Upholstery
- Window shades

Chrome Surfaces, Aluminum, and Stainless Steel Components

The following items ARE covered under this Warranty:

- Chrome peeling off in sheets
- Chrome cut at mounting bolts due to over-torque at the factory
- Bubbles in the chrome that are not caused by rock chips and/or general rust conditions
- Isolated rust along seams or welds

The following items are NOT covered under this Warranty:

- General rust (e.g., rust on the unfinished backside of a bumper)

DISCLAIMER: Failure to read or distribute this information does not provide exemption from compliance with the information contained herein. Specifications are subject to change without notice. Intended for general information only, not offered as customer's Warranty.

- Dimpling at the mounting bolts
- Staining, bluing, and/or yellowing that can be cleaned with a quality cleaning product
- Rust, pits, and/or nicks caused by road wash or road debris breaking the chrome surface
- Streaks/stains/corrosion caused by severe wash solutions or corrosive road salts/chemicals

Claims pertaining to failures of chrome surfaces, aluminum, and stainless steel components will not be processed unless a clear photo is provided that adequately shows the defect.

Clutch Adjustment

Clutch adjustments are normally required due to clutch wear and are considered normal maintenance. However, if the clutch adjustment is found to be outside of Company specifications during, or prior to, product in-service, a claim will be accepted on a one-time basis.

Claims for clutch adjustments will not be accepted unless the adjustment is found to be outside of Company specifications using the special clutch adjustment measuring tools provided by Company (e.g., adjusting the clutch to satisfy feel will not be accepted as Warranty).

Competition

Warranty will become void on any product that is used in competition including, but not limited to:

- Racing
- Tractor pulls
- Other motor sports

Consumable Parts

Parts that are subject to consumption during their normal service life and are routinely replaced during normal maintenance services are covered up to 15,000 miles (24 000 km) for all DTNA vehicles except TBB bodies and chassis. TBB consumable parts are covered up to 30 calendar days from the date of in-service. These items are:

- Antennas (exception: satellite radio antennas)
- Ashtrays
- Belts
- Brake linings
- Cigarette lighter assembly
- Clutch brake
- Clutch linings
- Data logger batteries
- Desiccant cartridges
- Fire extinguishers
- Flash tubes
- Fluorescent ballast and tubes
- Fuses
- Gladhand
- Hosetennas

DISCLAIMER: Failure to read or distribute this information does not provide exemption from compliance with the information contained herein. Specifications are subject to change without notice. Intended for general information only, not offered as customer's Warranty.

- Light bulbs*
- Lower center bumper air dam
- Mattresses
- Mud flaps
- Mud flap mounting brackets
- Caps (including, but not limited to, DEF, fuel, radiator, surge tank)
- Receiver-drier filter
- Trailer air hoses
- Trailer electrical cables
- Windshield washer nozzles
- Wiper arms and blades (TBB makes - wiper blades only)

* Sealed light and LED assemblies are not considered consumable.

The cost of consumable parts which are not reusable due to needed warrantable repairs is covered by this Warranty; examples include but are not limited to:

- Antifreeze
- Coolant
- Filters
- Fluids
- Grease/lubricants
- Oil

Corrosion

Coverage provides Warranty against corrosion to any metal or metal alloy part of the vehicle. Rust or corrosion to specific components and/or caused by certain conditions are excluded from all Company Warranty coverage and will not be paid under Basic Vehicle, Cab Structure, Cab Corrosion, Aftermarket Parts Warranty, or Extended Service Coverage.

Exclusions to corrosion Warranty include, but are not limited to, the following:

- Corrosion caused by general rust (e.g., rust on the unfinished backside of a bumper)
- Surface rust caused by chips or scratches in the paint or chrome surfaces
- Corrosion caused by high-pressure washing, severe wash solutions, cleaning solvents, detergents, compounds
- Corrosion caused by salinity in the environment or corrosive salts and/or chemicals used on the road surface
- Corrosion caused by acid rain or other industrial fallout
- Corrosion due to improper prevention measures during storage or use
- Corrosion or rust on tone rings, rotors, or drums
- Corrosion due to environmental damage (including ocean spray); airborne fallout (includes chemicals, tree sap, etc.), or other atmospheric conditions or other acts of nature
- Corrosion due to improper use, misuse, or abuse, negligence, including improper or insufficient maintenance

DISCLAIMER: Failure to read or distribute this information does not provide exemption from compliance with the information contained herein. Specifications are subject to change without notice. Intended for general information only, not offered as customer's Warranty.

Damage

The following are not covered under Warranty:

- Damage caused by use of the vehicle in any application that is not approved or is inconsistent with build specifications
- Damage resulting from improper use or misuse or abuse, negligence, improper operation, improper or insufficient maintenance (including, but not limited to, failure to maintain vehicle as outlined in the Driver's/Operator's and Maintenance Manuals), overloading, unauthorized modifications, accidents, or operation at excessive speeds
- Environmental damage, including airborne fallout (including chemicals, tree sap, etc.), or other atmospheric conditions, hailstones, or other acts of nature
- Damage caused by road salts/chemicals or cleaning solvents, detergents, or compounds
- Storage deterioration including damage caused by improper or insufficient storage or maintenance
- Damage caused by road hazards or road conditions
- Damage caused during shipping/transport after initial delivery of vehicle
- Damages (including peeling or flaking) caused by high-pressure washing or steam cleaning
- Damages occurring after in-service (e.g., from rock chips)
- Damages caused by customer-installed sealer in air conditioning systems
- Damages caused by non-factory approved engine horsepower/torque upgrades
- Damage due to vibration associated with misapplication or improper operation of drivetrain components
- Damage due to terrorist activities
- Damage due to acts of war

Engine

Any DTNA engine in a vehicle on which odometer mileage has been changed so the mileage cannot be readily determined is excluded from Warranty.

Non-DTNA engines, including all of its components as supplied by the non-Company engine manufacturer, are excluded from Warranty but are warranted separately by the manufacturer of the engine. For non-DTNA engine warranty or service, contact the engine manufacturer's authorized sales and service facility.

Engine Brakes, Air Compressors, and Other Proprietary Engine Components

The engine manufacturer installs most air compressors and engine brakes. Any failure of a proprietary engine component or Jake Brake® component must be filed directly to the engine manufacturer.

Failures on Company engines and non-proprietary engine components can be filed through DTNA.

Exhaust System Clamps

During the early life of the vehicle or when the engine is cold, many exhaust clamps exhibit a soot trace. This condition is self-correcting and does not require adjustment, tightening, or replacement of the clamp. Claims for adjusting or tightening will not be paid under Warranty.

DISCLAIMER: Failure to read or distribute this information does not provide exemption from compliance with the information contained herein. Specifications are subject to change without notice. Intended for general information only, not offered as customer's Warranty.

Fifth Wheels

Adjustment of the locking mechanism, bushings, slide locking plungers, and the repair or replacement of lock guards are considered routine maintenance and are not covered under this Warranty.

Glass, Mirrors, Lens

Conditions excluded from Warranty include but are not limited to:

- Breakage
- Chips
- Scratches
- Cracks

Initial Operating Period

During a vehicle's Initial Operating Period (IOP), repair on components found loose and included on a scheduled maintenance table may be reimbursed by Company. The IOP for DTNA vehicles is as follows:

Make	IOP ¹
Freightliner, Western Star	Up to 15,000 miles/24 000 km ²
FCCC	Up to 25,000 miles/40 000 km ²
TBB Bodies and TBB Chassis ³	Up to 6 months from in-service date

¹ IOP does not apply to powertrain components.

² The IOP begins at zero (0) distance; the in-service distance does not affect the IOP distance limits.

³ TBB applications utilizing FCCC chassis retain the FCCC IOP separate from the TBB body.

Routine maintenance, servicing, and adjustment, as defined in the applicable Vehicle Maintenance Manual and Driver's Manual, are excluded from Warranty.

Periodic adjustment or re-torque of wheel bearings, wheel lug nuts, and suspension U-bolts are considered maintenance adjustments and are not covered under Warranty.

Vibrations, squeaks, rattles, loose fittings/clamps, hose fitting leaks, loose nuts/bolts/screws, and loose electrical connections may develop during the initial trip(s) of the vehicle; associated repairs/adjustments are covered under Basic Warranty unless the distance at which the condition occurs exceeds the published maintenance interval for the component.

DISCLAIMER: Failure to read or distribute this information does not provide exemption from compliance with the information contained herein. Specifications are subject to change without notice. Intended for general information only, not offered as customer's Warranty.

- Components included on a scheduled maintenance table that have loosened at a time or distance exceeding the first scheduled maintenance or outside the IOP, whichever is greater, are not covered under Warranty and are the responsibility of the customer.

Components Found Loose and Included on a Scheduled Maintenance Table	Prior to First Scheduled Maintenance	After First Scheduled Maintenance
Within IOP	File Claim	File Claim
Outside IOP	File Claim	Customer Responsibility

- Components that do not appear on scheduled maintenance tables are not subject to IOP limitations and are covered per the applicable coverage and exclusions.

Consumable items are addressed separately from IOP; see [Consumable Parts](#) elsewhere in this section for details.

Exclusions from Warranty during the IOP are:

- Cab, hood, and fender-mounted mirrors are adjusted at the factory but may be retracted by the transporter to prevent damage during transport. Subsequent adjustments and tightening of mirror mounting hardware are considered part of the routine preparation of the vehicle before Customer delivery. Claims for adjusting the mirrors or tightening of the attaching hardware will not be paid under Warranty during or after the IOP.
- Claims for re-routing of electrical wiring, hoses, or lines which meet DTNA’s routing standards will not be paid under Warranty during or after the IOP. However, if during the IOP, evidence of a potential failure (e.g., rubbing or chaffing that would lead to a short in a wire or a hole in a hose/line) is found where a line, hose, or electrical wiring is mis-installed and is making contact with one of the following, a one-time claim for correcting the routing will be accepted:
 - Hot surface
 - Moving part
 - Sharp edge

Such claims should be filed with *28 - Part Improperly Installed* as the Cause code; photos that clearly show evidence of rubbing or chaffing due to mis-installation must be available upon request.

Note: Preventative re-routing for other conditions not listed above is not considered warrantable. However, if a line, hose, or electrical wiring actually fails (i.e., leaks or shorts) due to rubbing or chaffing on any surface, such failures are covered per the applicable coverage and exclusions.

- Final preparation of the vehicle for Customer delivery to include cleaning/vacuuming interior of cab, washing windows, washing the exterior of the vehicle, and polishing exterior chromed or painted surfaces are considered as ordering location responsibilities. Claims for these activities will not be paid under Warranty during or after the IOP.

Loose Components

During the manufacturing process, certain components are placed in the cab of the vehicle or strapped down to the chassis. It is the service location’s responsibility to mount these shipped loose items in the correct location on the vehicle. Mounting the shipped loose items below will not be covered under Warranty.

These items include, but may not be limited to:

DISCLAIMER: Failure to read or distribute this information does not provide exemption from compliance with the information contained herein. Specifications are subject to change without notice. Intended for general information only, not offered as customer’s Warranty.

- Aerodynamic wheel covers
 - Exception: Mounting covers on Freightliner Cascadia trucks may be reimbursed; varies by model/specifications
- Antennas
- Chrome lug nut covers
- Decals & paperwork
- Driver's pouch
- Fire extinguishers
- Jacks
- License plate brackets
- Mattress
- Reflectors with flares
- Reflectors without flares
- Spare wheels/tires
- Tire inflation hoses
- Trailer cables (air/electrical)
- Winter fronts

Misapplication of Product

The Warranty on any product used inconsistent with its specified vocation/application will be downgraded to the Warranty that is consistent with product use. Any and all claims associated with the misapplication of the product will be subject to chargeback.

Miscellaneous Expenses

Premium charges and work not directly related to the repair or replacement of a warranted part are not reimbursed, unless specifically stated elsewhere in the applicable Warranty coverage. Examples include, but are not limited to:

- Federal, state, provincial, and local taxes
- Travel expenses
- Loss of revenue
- Customer labor, including overtime labor
- Downtime
- Driver's expenses
- Cost of rental equipment
- Loss of cargo, including perishable cargo
- General housekeeping and bulk shop supplies (e.g., shop rags, solvents, sweeping compounds, coveralls, etc.)
- Communication charges
- Towing/road call assistance
- For non-powertrain component repairs, the removal, repair, or replacement of:

DISCLAIMER: Failure to read or distribute this information does not provide exemption from compliance with the information contained herein. Specifications are subject to change without notice. Intended for general information only, not offered as customer's Warranty.

- Components/parts and optional items that are not sold or installed by Company
- Equipment installed by a body builder, customer, or service location
- Dynamometer testing on non-Company engines after repairs have been performed
- Shop hardware supplies that are not itemized on the claim as “parts used” (e.g., common bolts, washers, nuts, tie straps, cotter pins, etc.)
- Time spent waiting at a counter to obtain a part, etc.
- Environmental fees, cleanup, or other charges
- Cost of emergency services

Modifications to Original Equipment

Company does not warrant product modifications or equipment installations unless performed at a Company Custom Truck Services (CTS) Center. In addition, the extra time necessary to remove body builder-installed items and/or equipment to work on a warrantable repair is not covered under this Warranty unless Company sells the complete chassis/body/equipment as a package.

If service locations or Customers perform any product modifications or equipment installations, to the extent these modifications or equipment installations adversely affect other vehicle components or vehicle performance, Company shall not accept any product liability or claims under the terms of the product Warranty. These claims become the sole responsibility of the person performing the modifications or equipment installations.

Paint

The following exclusions to paint warranty include, but are not limited to:

- Complete chassis re-painting to repair paint damages
- Damages occurring after in-service (e.g., from rock chips)
- Peeling/flaking caused by high-pressure washing or steam cleaning
- Rusting of painted bumpers
- Removal and/or replacement of decals, striping, and/or lettering not applied by Company

Specific areas of the vehicle are deliberately not painted or are not painted to any standard; paint repairs are not warrantable to such areas. These areas include:

- Underside of the hood, including the inside of the wheel wells
- Underside of the roof-mounted air fairings
- Underside of the exterior sun visor
- Inside of the side-mounted air fairings
- Inside of the bumper
- Aftertreatment devices

Gloss

Gloss claims pertaining to gloss issues on vehicles painted with low-gloss colors (as identified in the Truck/Bus Sales Order) will not be covered under Warranty.

DISCLAIMER: Failure to read or distribute this information does not provide exemption from compliance with the information contained herein. Specifications are subject to change without notice. Intended for general information only, not offered as customer's Warranty.

Routine Maintenance

Routine or preventative maintenance, servicing, and adjustment, as defined in the applicable Vehicle Maintenance Manual and Driver's Manual, are excluded from Warranty.

Periodic adjustment or re-torque of wheel bearings, wheel lug nuts, and suspension U-bolts are considered maintenance adjustments and are not covered under Warranty.

Vibrations, squeaks, rattles, loose fittings/clamps, hose fitting leaks, loose nuts/bolts/screws, and loose electrical connections may develop during the initial trip(s) of the vehicle and these types of repairs/adjustments are covered under Warranty one (1) time during the applicable IOP unless excluded above.

Reminder: After the IOP, these developments are the result of use and their repair/adjustment activities are considered routine maintenance and thus excluded from Warranty.

Tampering/Misuse

Conditions resulting from tampering, misuse, improper adjustments, alteration, accident, failure to use recommended fuel or non-performance of required maintenance services are not covered.

It is a violation of U.S. federal law to alter the engine, exhaust plumbing, after treatment system, diesel exhaust fluid system, or other vehicle components in any way that would bring the engine/vehicle out of compliance with certification requirements [Ref: 42 U.S.C. §7522(a)(3)]. It is the Owner's responsibility to maintain the vehicle so that it conforms to EPA regulations.

Test Products

Any product(s) used in testing must be identified to the Warranty Department and accommodations must be made for claims that relate to the test item(s).

Any product used in endurance testing, such as the Altoona Test, are void of all Warranty, including but not limited to New Product Warranty, Aftermarket Parts Warranty, Extended Service Coverage, or any Company additional or used truck coverage.

Tires and Tire Balancing

The tires are not covered under this Warranty, but are warranted separately by the tire manufacturer. Tire balancing is not covered under Warranty.

Transmissions (Non-Company)

Allison transmissions and components are not covered under this Warranty, but are warranted separately by Allison. Information regarding Allison's warranty is provided for informational purposes only and is subject to change. For warranty or service information, contact Allison's authorized sales and service facility.

Eaton Hybrid transmissions are not covered under this Warranty.

3.8 Transfer of Warranty

This Warranty is transferable to a subsequent Owner if it has not expired. To ensure the Owner receives proper Warranty recognition, the ownership information should be updated in OWL.

DISCLAIMER: Failure to read or distribute this information does not provide exemption from compliance with the information contained herein. Specifications are subject to change without notice. Intended for general information only, not offered as customer's Warranty.

3.9 Change of Owner Address Information

To ensure Company's ability to reach the current Owner with Recall and Field Service campaign information, the Owner's information must be updated whenever there is a change to the Owner's name or address.

3.10 Product Improvement

Company reserves the right to make improvements or changes to the product at any time without incurring any obligation to make such changes or improvements to any other vehicle.

3.11 Owner's Responsibilities

DTNA provides Owner's Warranty Information booklets for Company products. When the Owner first receives a Company product, the service location should review the Owner's Warranty Information booklet(s) with the Owner. It is important that the new Owner becomes familiar with the contents about Warranty, parts replacement that affects emission controls, and maintenance service. It is the Owner's responsibility to ensure the product is maintained as outlined in the Driver's/Operator's and Maintenance Manuals and to maintain the vehicle so that it conforms to EPA regulations.

To initiate Warranty, the customer must complete and sign the Warranty Start Form (WAR275); service locations keep the signed form on file and register the vehicle with DTNA for Warranty.

As soon as a problem exists, the Owner is responsible for presenting the product to an Authorized Service Location. The Warranty repairs should be completed in a reasonable amount of time. The Owner should also be aware that DTNA may deny Warranty coverage if the product has failed due to abuse, neglect, improper maintenance, or unapproved modifications. DTNA recommends that Owners retain all receipts regarding product maintenance but Company cannot deny Warranty solely for the lack of receipts.

DISCLAIMER: Failure to read or distribute this information does not provide exemption from compliance with the information contained herein. Specifications are subject to change without notice. Intended for general information only, not offered as customer's Warranty.