

DRAWING NOTES

- THESE DRAWINGS ARE FOR INFORMATION PURPOSES ONLY. ALL CONSTRUCTION SHALL CONFORM TO ALL LOCAL CODES AND PRACTICES.
- ALL VALUES MAY CHANGE WITHOUT NOTICE.
- DO NOT SCALE THIS DRAWING.
- ALL CONNECTIONS AND SERVICES SHALL BE MADE BY QUALIFIED TECHNICIANS.

EQUIPMENT SPECIFICATIONS

MODEL NUMBER	DESCRIPTION	QTY	MACHINE CAPACITY	EXTENDED CAPACITY
SCT100VCOV	SPEED QUEEN 100lb. HARDMOUNT WASHER-EXTRACTOR	1	100 lbs.	100 lbs.
SCT080VCOV	SPEED QUEEN 80lb. HARDMOUNT WASHER-EXTRACTOR	2	80 lbs.	160 lbs.
SCT060VCOV	SPEED QUEEN 60lb. HARDMOUNT WASHER-EXTRACTOR	5	60 lbs.	300 lbs.
SCT040VCOV	SPEED QUEEN 40lb. HARDMOUNT WASHER-EXTRACTOR	7	40 lbs.	280 lbs.
SCT020VCOV	SPEED QUEEN 20lb. HARDMOUNT WASHER-EXTRACTOR	6	20 lbs.	120 lbs.
TOTAL WASH CAPACITY:				960 lbs.
MODEL NUMBER	DESCRIPTION	QTY	MACHINE CAPACITY	EXTENDED CAPACITY
ST075N	SPEED QUEEN 75lb. SINGLE POCKET TUMBLE DRYER	3	75 lbs.	225 lbs.
ST145N	SPEED QUEEN 45lb. STACKED TUMBLE DRYER	6	90 lbs.	540 lbs.
ST130N	SPEED QUEEN 30lb. STACKED TUMBLE DRYER	3	60 lbs.	180 lbs.
TOTAL DRY CAPACITY:				945 lbs.
WASH TO DRY RATIO:				1 : .98

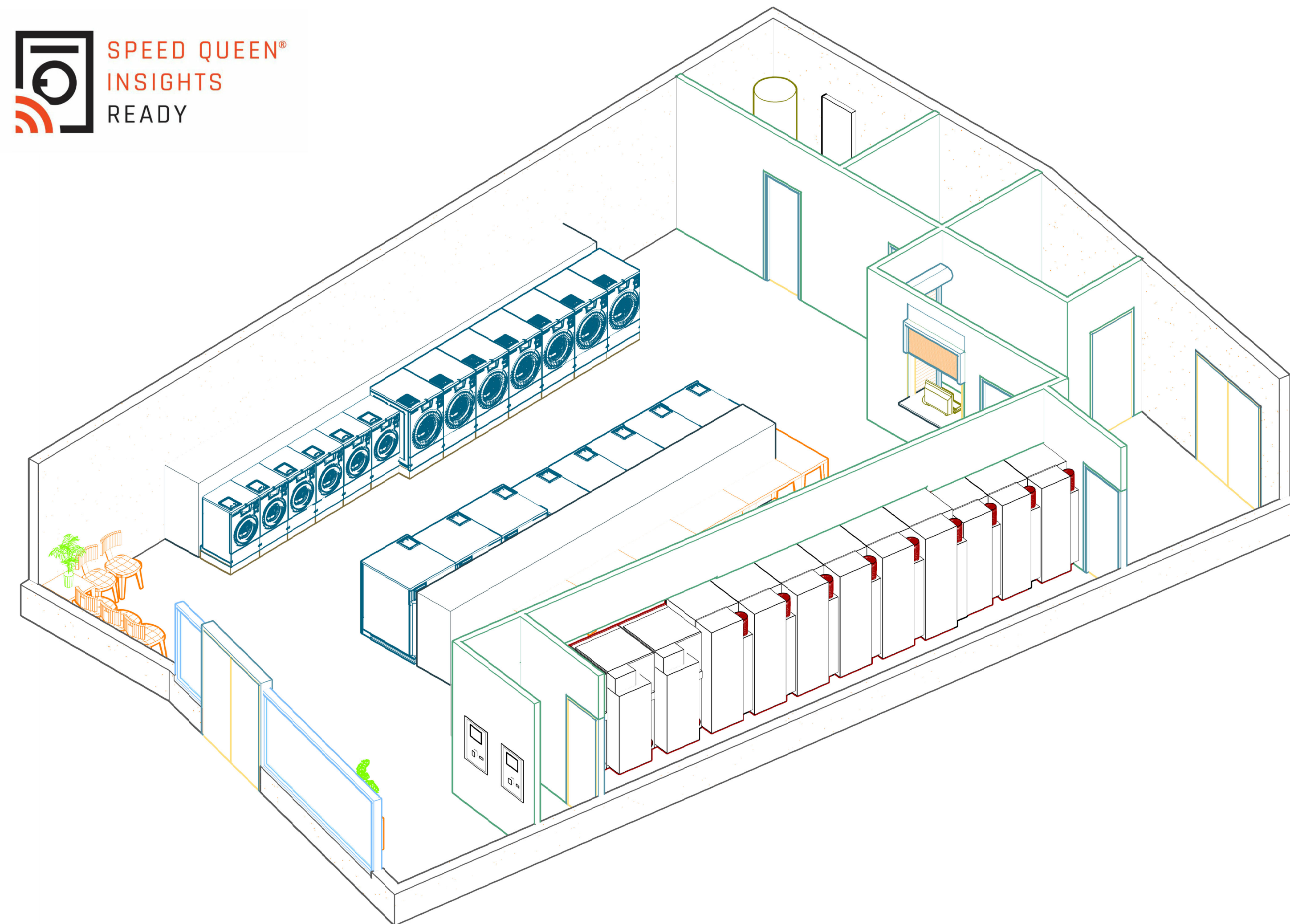
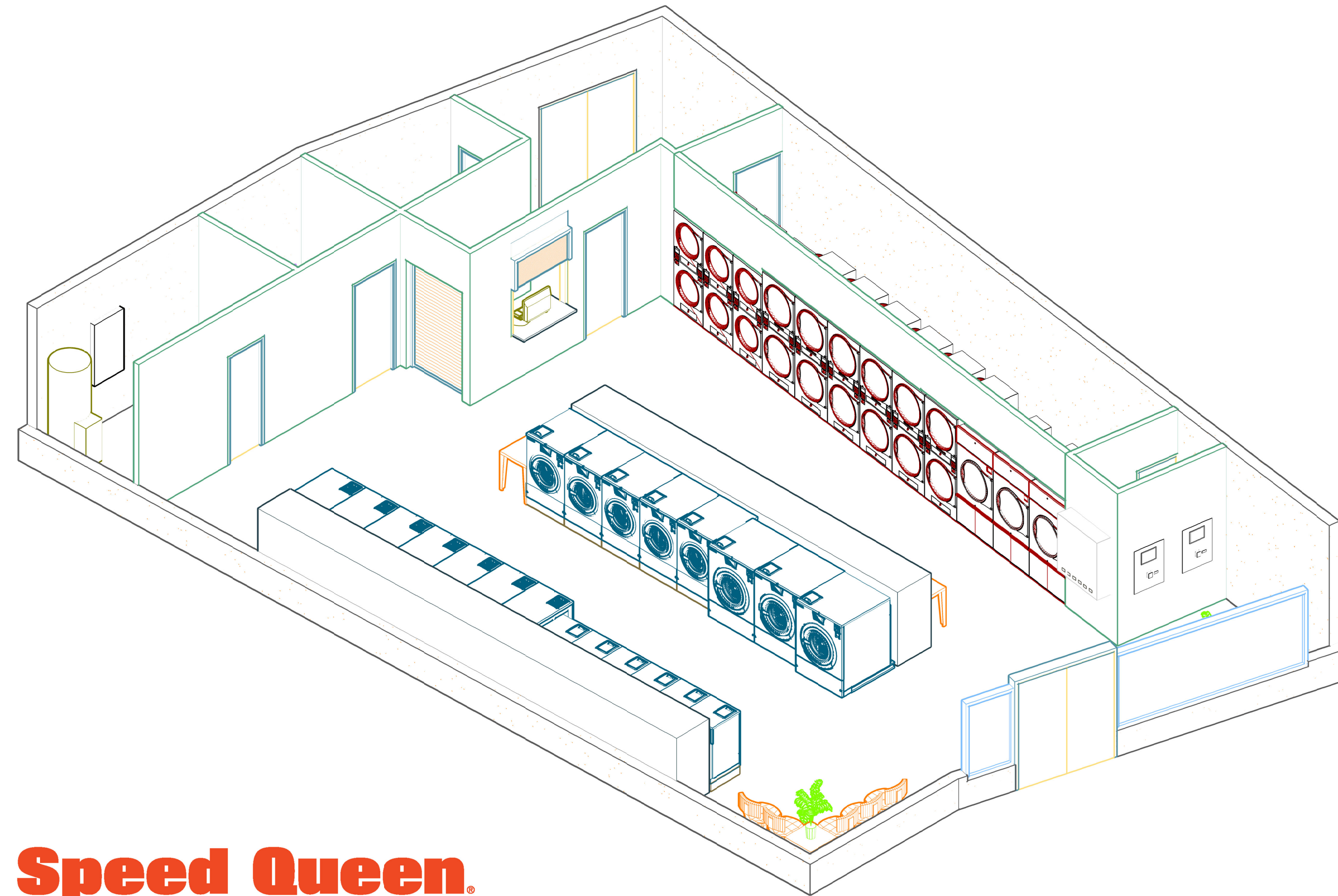

Speed Queen
The Proven Performer in Laundry

PROJECT:

30441 EUCLID AVE

PROJECT NUMBER:

LDR-4412

AREA:

1625

EQUIPMENT DISTRIBUTOR:

Alliance Laundry
1 Shepard Street
Ripon, WI, 54971

DRAWN BY:

LAD

TITLE OF SHEET:

COVER SHEET

SHEET NUMBER:

SHEET 1 OF 5

DATE:

8-Mar-23

NOT FOR CONSTRUCTION PURPOSES. Equipment specifications are subject to change without notice. Please see equipment installation manuals for updated equipment installation requirements.

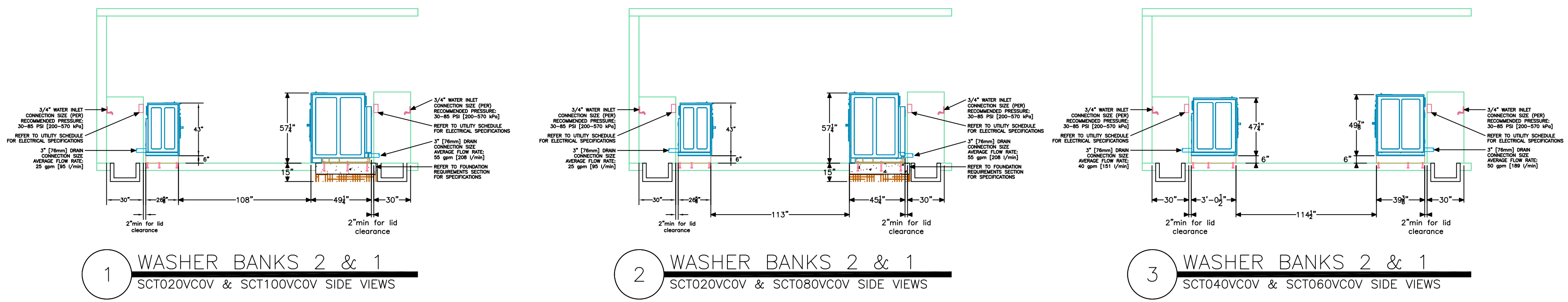
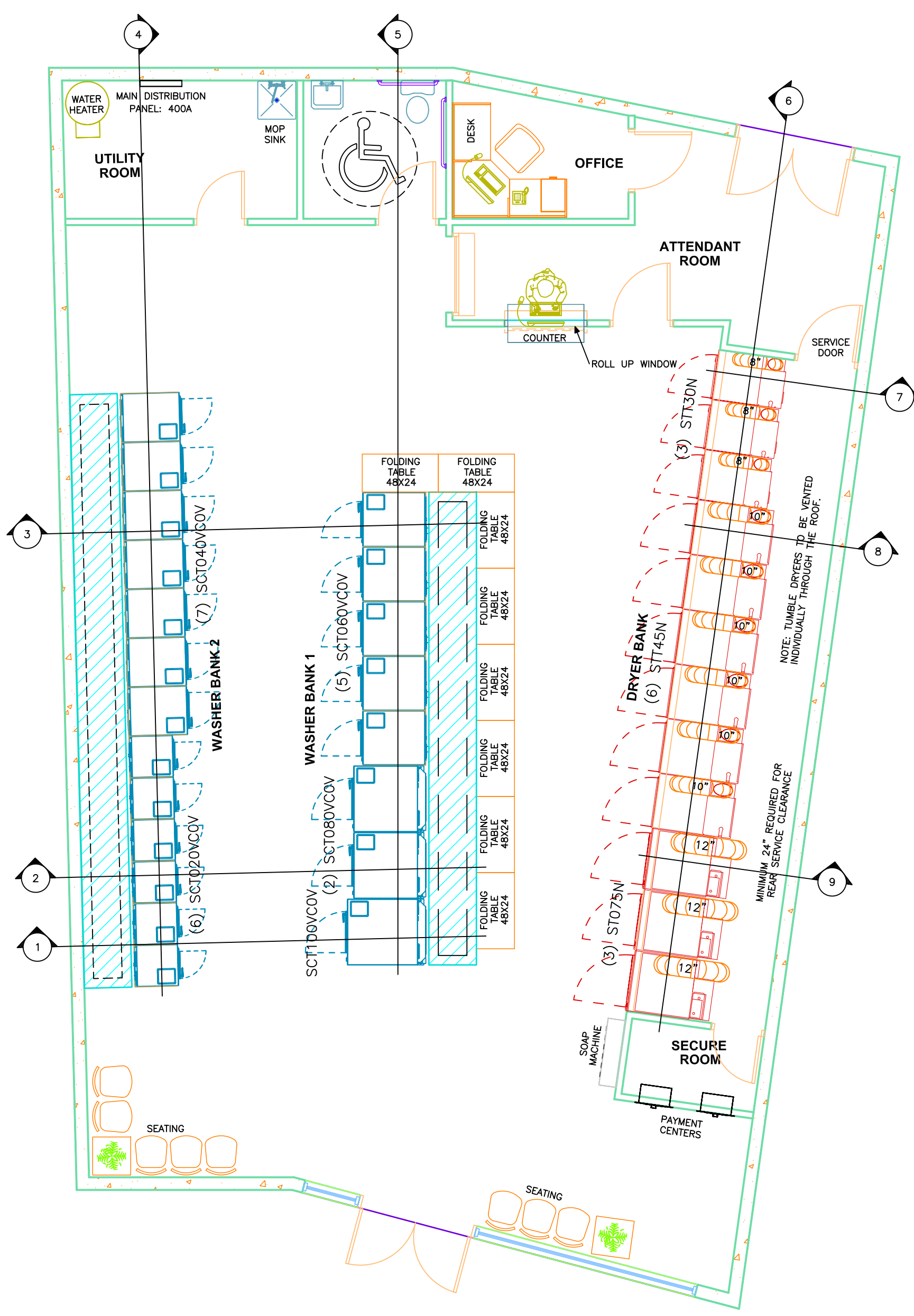

1 WASHER BANKS 2 & 1
SCT020VC0V & SCT100VC0V SIDE VIEWS

2 WASHER BANKS 2 & 1
SCT020VC0V & SCT080VC0V SIDE VIEWS

3 WASHER BANKS 2 & 1
SCT040VC0V & SCT060VC0V SIDE VIEWS

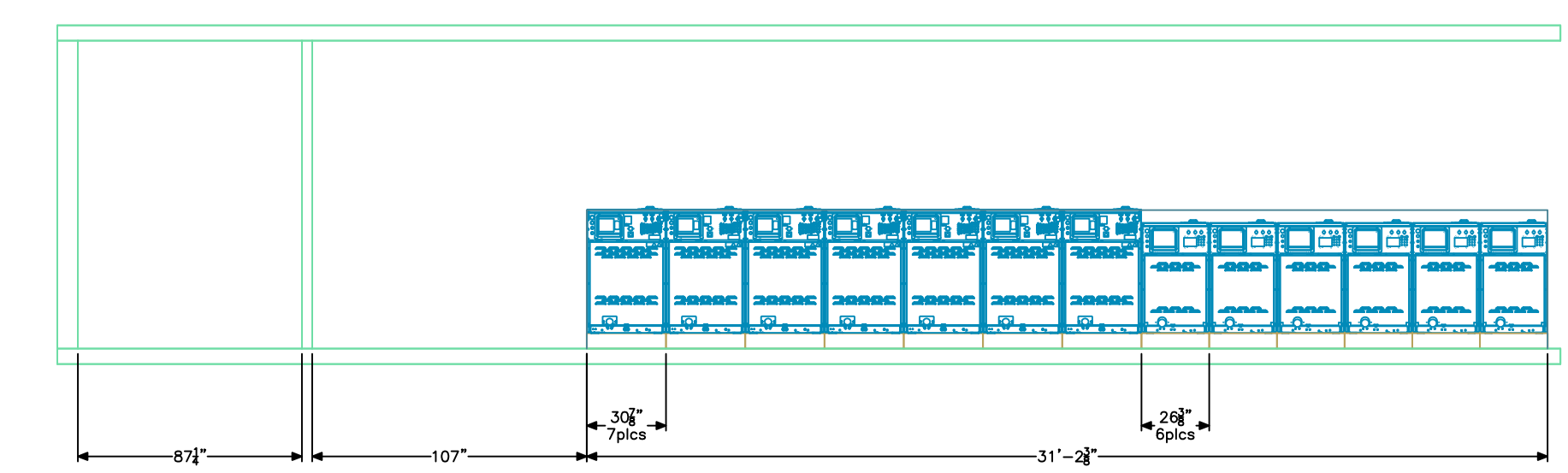

4 WASHER BANK 2
SCT040VC0V & SCT020VC0V BACK VIEWS

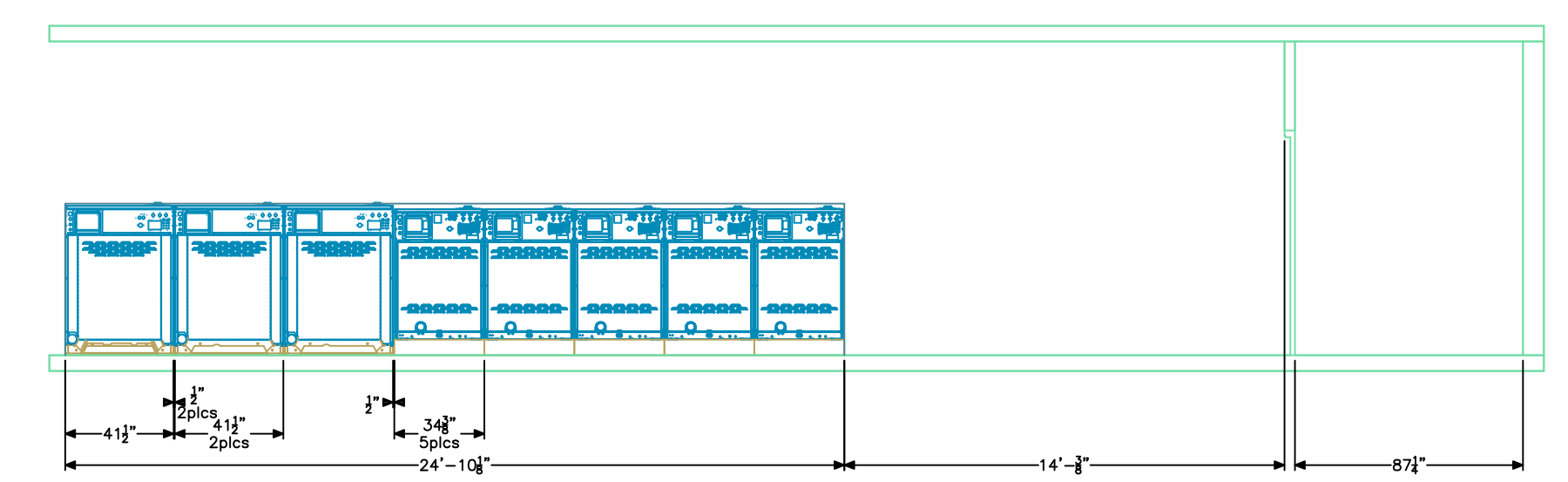

5 WASHER BANK 1
SCT100VC0V, SCT080VC0V & SCT060VC0V BACK VIEWS

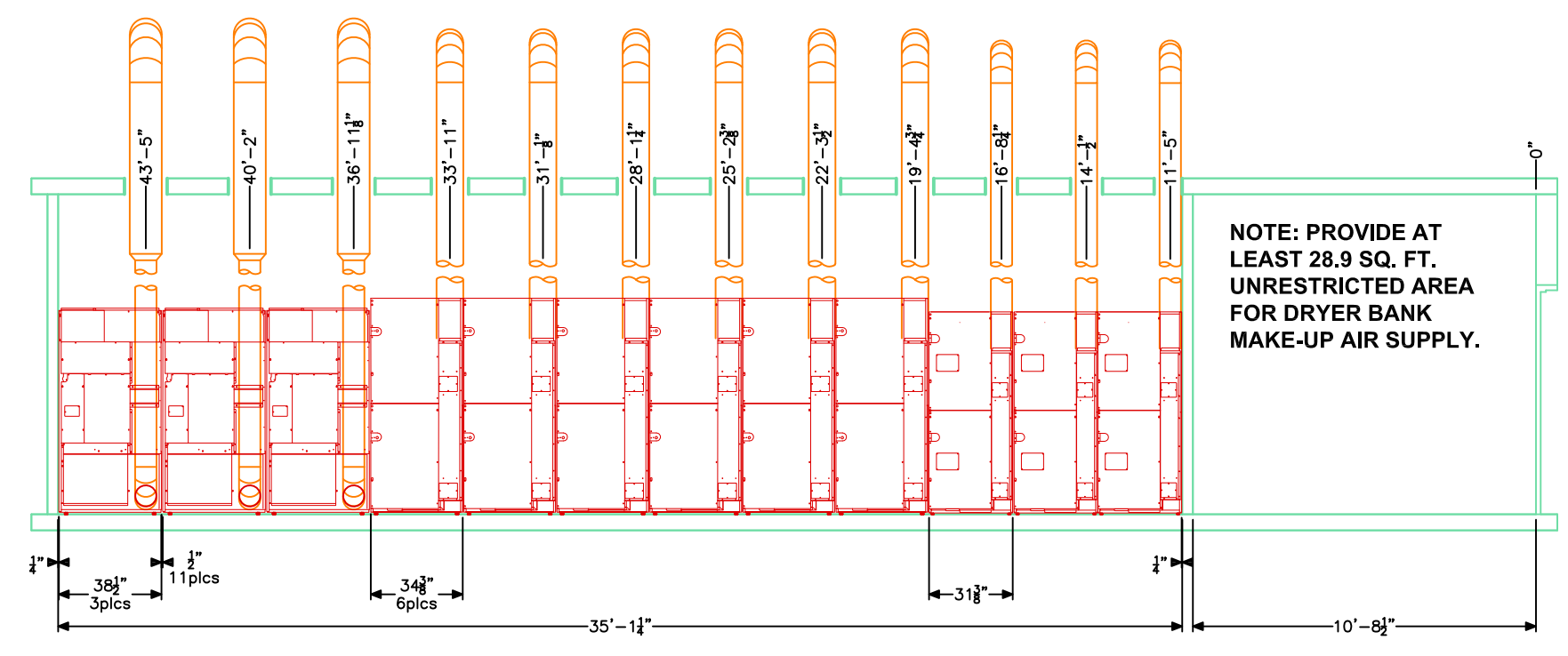

6 DRYER BANK
ST075N, STT45N & STT30N BACK VIEWS

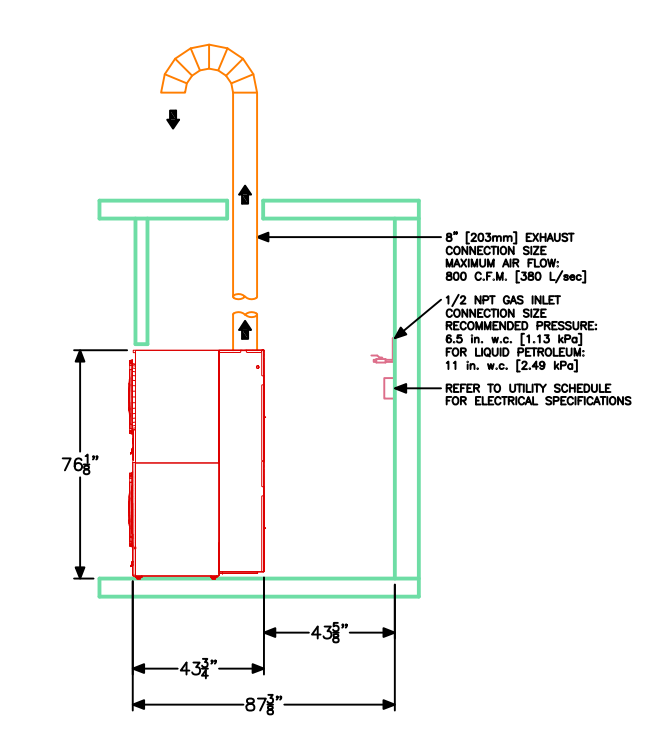

7 DRYER BANK
STT30N SIDE VIEW

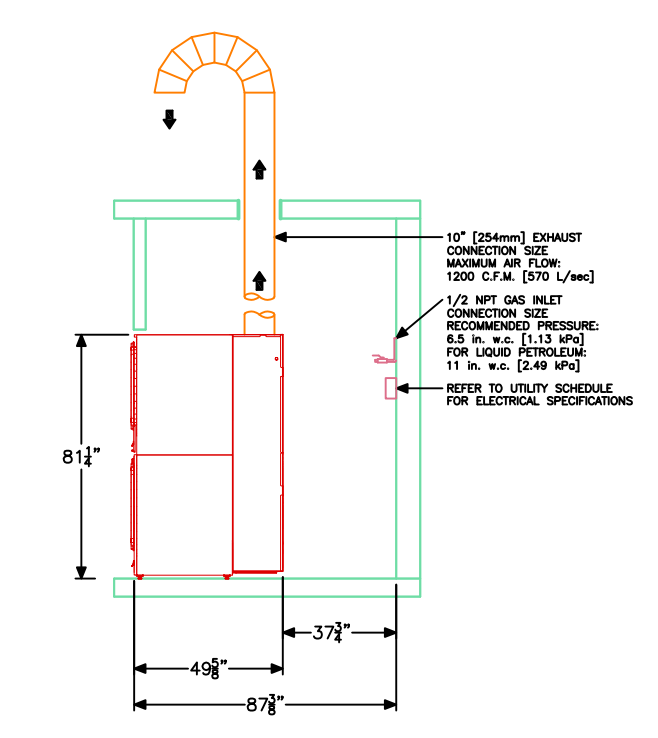

8 DRYER BANK
STT45N SIDE VIEW

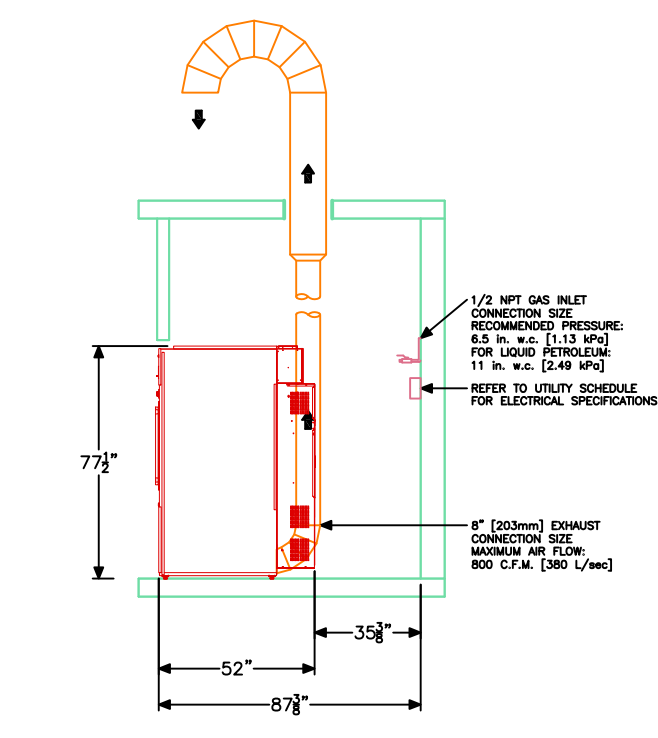

9 DRYER BANK
ST075N SIDE VIEW



Speed Queen
The Proven Performer in Laundry

PROJECT:
30441 EUCLID AVE

PROJECT NUMBER:
LDR-4412

AREA:
1625

EQUIPMENT DISTRIBUTOR:
Alliance Laundry
1 Shepard Street
Ripon, WI, 54971

DRAWN BY:
LAD

TITLE OF SHEET:
EQUIPMENT ELEVATIONS

SHEET NUMBER:
SHEET 2 OF 5

DATE:
8-Mar-23

NOT FOR CONSTRUCTION PURPOSES.
Equipment specifications are subject to change without notice. Please see equipment installation manuals for updated equipment installation requirements.

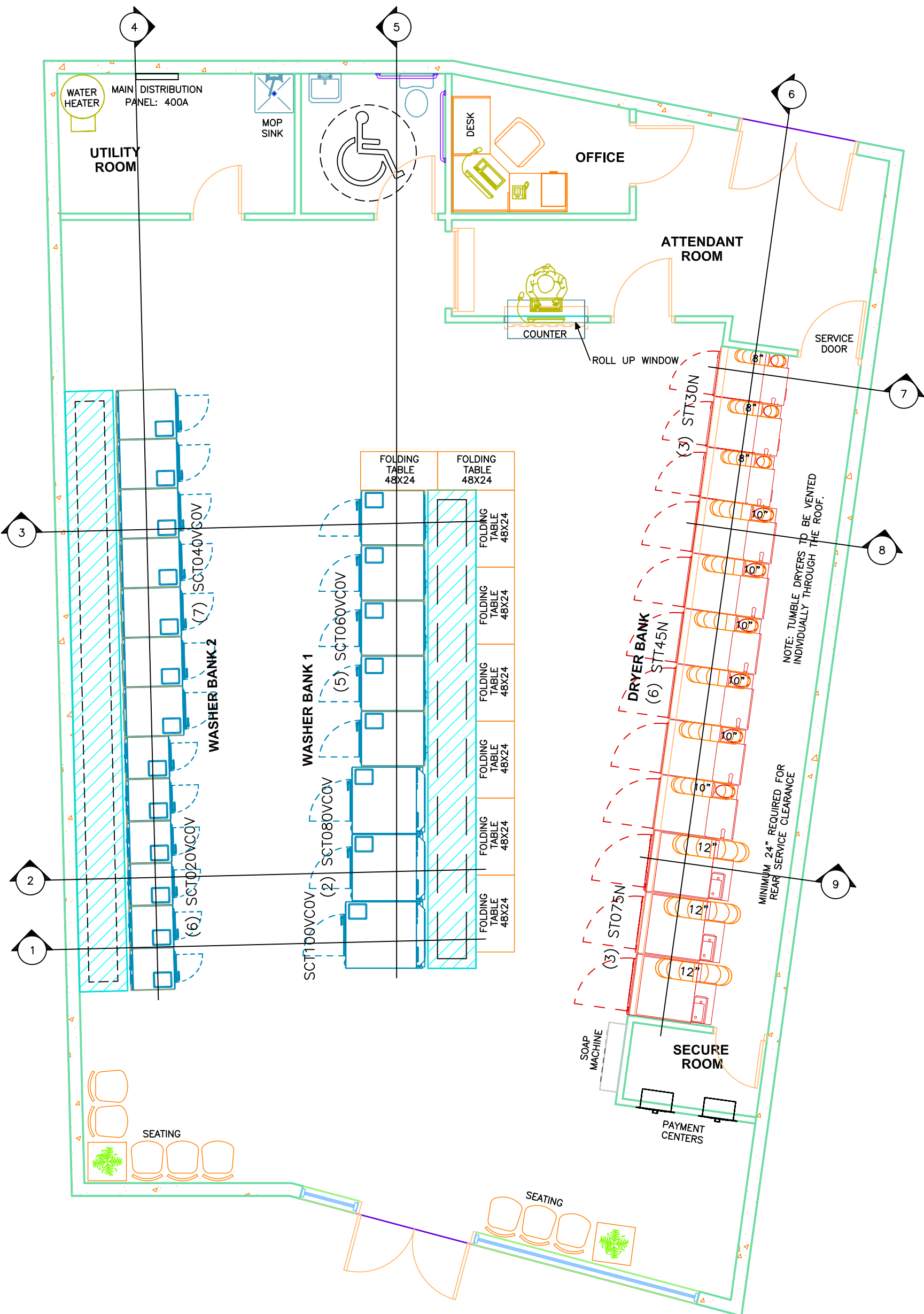

LAUNDRY EQUIPMENT LIST					
ITEM	MANUFACTURER	MODEL	DESCRIPTION	QTY.	FUTURE
1	SPEED	SCT100VCOV	WASHER-EXTRACTOR	1	
2	SPEED	SCT080VCOV	WASHER-EXTRACTOR	2	
3	SPEED	SCT060VCOV	WASHER-EXTRACTOR	5	
4	SPEED	SCT040VCOV	WASHER-EXTRACTOR	7	
5	SPEED	SCT020VCOV	WASHER-EXTRACTOR	6	
6	SPEED	STT45N	STACK TUMBLER	6	
7	SPEED	ST075N	TUMBLER	3	
8	SPEED	STT30N	STACK TUMBLER	3	

DRAIN OUTLET SIZE		
MODEL	MACHINE DRAIN OUTLET	ESTIMATED DRAIN LINE FOR EACH BULKHEAD
SCT100VCOV	3"	
SCT080VCOV	3"	
SCT060VCOV	3"	
SCT040VCOV	3"	
SCT020VCOV	3"	TROUGH DRAIN

IMPORTANT: MACHINE MUST BE INSTALLED IN ACCORDANCE WITH LOCAL CODES AND ORDINANCES.

IMPORTANT: THE ESTIMATED DRAIN LINE FOR EACH BULKHEAD IS BASED ON THE DRAIN FLOW CAPACITY OF EACH MACHINE, AND ONLY TAKES INTO ACCOUNT THE LAUNDRY EQUIPMENT REQUIREMENTS. WHEN CONDUCTING FINAL SIZING OF THE OUTGOING SEWER LINE, A PROFESSIONAL SHOULD BE CONSULTED AS FIGURES MAY VARY BASED ON LOCAL CODE REGULATIONS, DISTANCE AND CONFIGURATION OF PLUMBING, AND OTHER SEWER REQUIREMENTS FROM NON-LAUNDRY FIXTURES.

ELECTRICAL REQUIREMENTS					
MODEL	VOLTAGE/CYCLE/PHASE	FULL LOAD AMP DRAW	CIRCUIT BREAKER	WIRE SIZE AWG (mm)	
SCT100VCOV	200-240/50-60/1ø	16A	20A	12 [4]	
SCT080VCOV	200-240/50-60/1ø	15A	20A	12 [4]	
SCT060VCOV	200-240/50-60/1ø	11A	15A	14 [2.5]	
SCT040VCOV	200-240/50-60/1ø	7A	15A	14 [2.5]	
SCT020VCOV	200-240/50-60/1ø	4A	15A	14 [2.5]	
STT45N	200-240/50-60/1ø	12A	15A	14 [2.5]	
ST075N	200-240/50-60/1ø	7A	15A	14 [2.5]	
STT30N	200-240/50-60/1ø	9A	15A	14 [2.5]	
TOTALS		294.0A			

NOTE: ELECTRICAL RATINGS ARE SUBJECT TO CHANGE WITHOUT NOTICE. REFER TO SERIAL PLATE FOR ELECTRICAL RATINGS INFORMATION SPECIFIC TO YOUR MACHINE.

NOTE: ELECTRIC HEATED STACK DRYER AND STACK 30 TUMBLER DRYER FULL LOAD AMPS AND CIRCUIT BREAKERS ARE SHOWN PER POCKET. PLEASE CONSULT INSTALLATION MANUAL FOR SPECIFICATIONS.

IMPORTANT: FOR PERSONAL SAFETY AND PROPER OPERATION, THE MACHINE MUST BE GROUNDED IN ACCORDANCE WITH STATE AND LOCAL CODES.

NOTE: CONNECTIONS MUST BE MADE BY A QUALIFIED ELECTRICIAN. REFER TO THE MANUFACTURER'S INSTALLATION MANUAL FOR MORE DETAILS AND ELECTRICAL REQUIREMENTS.

DYNAMIC LOAD SPECIFICATIONS				
MODEL	STATIC LOAD, LBS/FT ²	DYNAMIC LOAD, LBS/FT ²	MAXIMUM DYNAMIC LOAD, LBS/FT ²	DYNAMIC LOAD FREQUENCY, Hz
SCT100VCOV	149	149	4330	9.5
SCT080VCOV	140	149	4330	10.4
SCT060VCOV	105	143	2770	11.4
SCT040VCOV	98	119	1820	12.2
SCT020VCOV	97	96	805	13.7

IMPORTANT: THOROUGHNESS OF DETAIL MUST BE STRESSED WITH ALL FOUNDATION WORK TO ENSURE A STABLE UNIT INSTALLATION, ELIMINATING POSSIBILITIES OF EXCESSIVE VIBRATION DURING EXTRACT. REFER TO THE MANUFACTURER'S INSTALLATION MANUAL FOR MORE DETAILS.

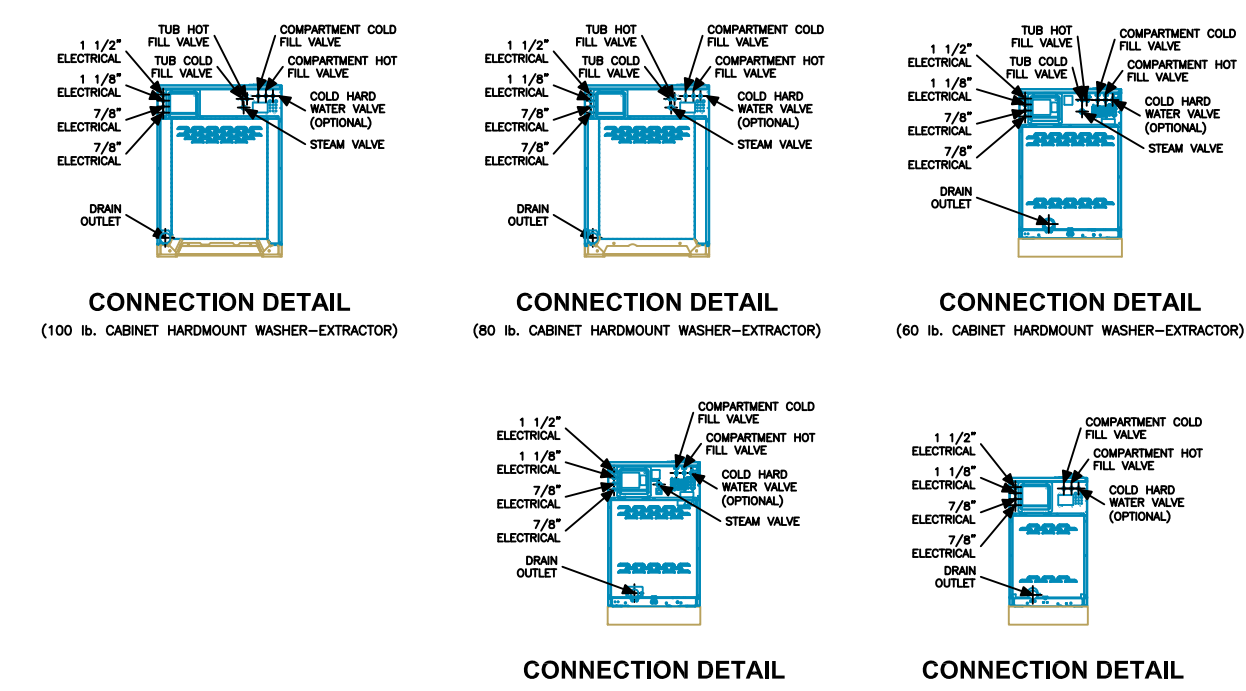

GAS INLET SIZE				
MODEL	OPERATING PRESSURE (PSIG)	GAS TYPE	MAX BTU/HOUR	ESTIMATED GAS SUPPLY LINE SIZE
STT45N	7"±1.5"	NATURAL	190000	1/2"
ST075N	7"±1.5"	NATURAL	165000	1/2"
STT30N	7"±1.5"	NATURAL	146000	1/2"
TOTAL			2073000	3"

NOTE: IT IS IMPORTANT THAT EQUAL PRESSURE BE MAINTAINED AT ALL TUMBLE DRYER GAS CONNECTIONS. THIS CAN BE DONE BY INSTALLING A 1" (25.4mm) PIPE GAS LOOP TO MAINTAIN EQUAL PRESSURE AT ALL GAS CONNECTIONS.

IMPORTANT: THE ESTIMATED GAS SUPPLY LINE SIZE IS BASED ON A 0.5 PSI (0.04 bar) SUPPLY SYSTEM AND 60' (18m) LENGTH OF PIPE, AND ONLY TAKES INTO ACCOUNT THE LAUNDRY EQUIPMENT REQUIREMENTS. WHEN CONDUCTING FINAL SIZING OF THE INCOMING GAS LINE, A PROFESSIONAL SHOULD BE CONSULTED AS FIGURES MAY VARY BASED ON SUPPLY SYSTEM SIZE, LOCAL CODE REGULATIONS, DISTANCE AND CONFIGURATION OF PIPING, AND OTHER GAS REQUIREMENTS FROM NON-LAUNDRY FIXTURES.

EXHAUST/VENT OUTLET SIZE			
MODEL	SIZE	AIR FLOW	MIN. CROSS SECT. AREA, SQ. IN.
STT45N	10"	1200 cfm	6x98 sq in.
ST075N	8"	800 cfm	3x63 sq in.
STT30N	8"	800 cfm	3x63 sq in.

PROVIDE A MINIMUM 28.9 SQ FT OF MAKE-UP AIR OPENING FOR ALL DRYERS.

NOTE: THE MAKE-UP AIR IS SIZED BASED ON A LOUVERED INSTALLATION. AN ADDITIONAL 40% HAS BEEN ADDED DUE TO POSSIBLE AIR FLOW RESTRICTIONS.

NOTE: THIS FIGURE IS CALCULATED BASED ONLY ON THE DRYERS. OTHER GRAVITY VENTED APPLIANCES PRESENT WILL REQUIRE THE MAKE-UP AIR OPENING(S) TO BE INCREASED SUFFICIENTLY TO PREVENT DOWNDRAFTS IN ANY OF THE VENTS.

WATER INLET SUPPLY											
MODEL	COLD WATER		HOT WATER		AVERAGE HOT WATER USAGE IN GALLONS/CYCLE	MAXIMUM VALVE FLOW GALLONS/MINUTE		REQUIRED LINE SIZE TO SUPPLY MACHINE		ESTIMATED WATER LINE SUPPLY SIZE	
	CONNECTION SIZE	OPTIMUM PRESSURE	CONNECTION SIZE	OPTIMUM PRESSURE		COLD	HOT	COLD	HOT	COLD	HOT
SCT100VCOV	3/4"	30lbs	3/4"	30lbs	19	11.5	11.5	3/4"	3/4"		
SCT080VCOV	3/4"	30lbs	3/4"	30lbs	16.4	11.5	11.5	3/4"	3/4"		
SCT060VCOV	3/4"	30lbs	3/4"	30lbs	11.8	9.3	9.3	3/4"	3/4"		
SCT040VCOV	3/4"	30lbs	3/4"	30lbs	9.6	5.3	5.3	3/4"	3/4"		
SCT020VCOV	3/4"	30lbs	3/4"	30lbs	5.0	5.3	5.3	3/4"	3/4"	2 1/2"	2 1/2"

NOTE: THE AVERAGE HOT WATER PER CYCLE FIGURE IS PER MACHINE, AND WAS CALCULATED BASED ON 60 PSI OPERATING PRESSURE. ALL HOT WATER USAGE FIGURES ARE ESTIMATED. ACTUAL CONSUMPTION FIGURES WILL VARY DEPENDING ON LOCAL WATER PRESSURES, EQUIPMENT CONDITION, NUMBER OF CYCLES, CYCLE TIMES SELECTED, LOAD SIZES AND THE TYPE OF MATERIALS PROCESSED.

IMPORTANT: THE ESTIMATED WATER LINE SUPPLY SIZE IS BASED ON OPTIMUM WATER PRESSURE, AND ONLY TAKES INTO ACCOUNT THE LAUNDRY EQUIPMENT REQUIREMENTS. WHEN CONDUCTING FINAL SIZING OF THE INCOMING WATER LINE, A PROFESSIONAL SHOULD BE CONSULTED AS FIGURES MAY VARY BASED ON WATER PRESSURE AVAILABILITY, PLUMBING REGULATION REQUIREMENTS, DISTANCE AND CONFIGURATION OF PIPING, AND OTHER WATER REQUIREMENTS FOR NON-LAUNDRY FIXTURES.

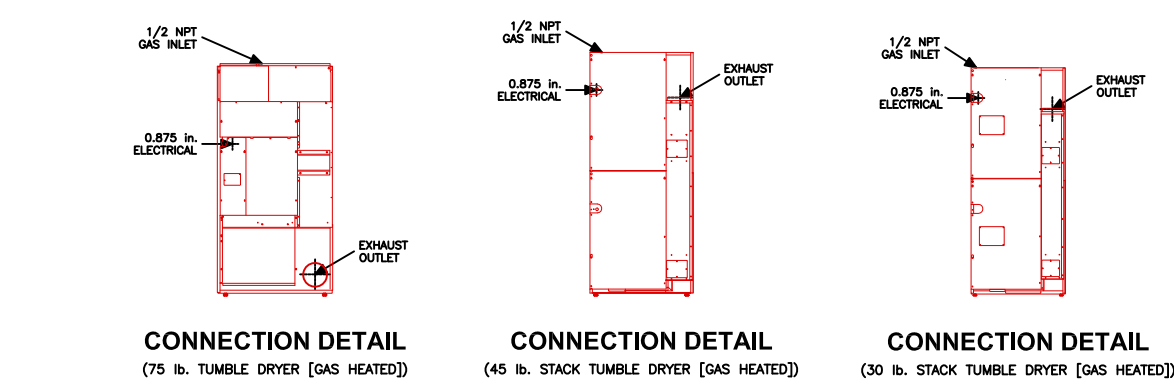

NOTE: IT IS IMPORTANT THAT EQUAL PRESSURE BE MAINTAINED AT ALL TUMBLE DRYER GAS CONNECTIONS. THIS CAN BE DONE BY INSTALLING A 1 INCH PIPE GAS LOOP TO MAINTAIN EQUAL PRESSURE AT ALL GAS CONNECTIONS.

BEFORE INSTALLATION, CHECK THAT THE LOCAL DISTRIBUTION CONDITIONS NATURE OF GAS AND PRESSURE, AND THE ADJUSTMENT OF THE APPLIANCE ARE COMPATIBLE.

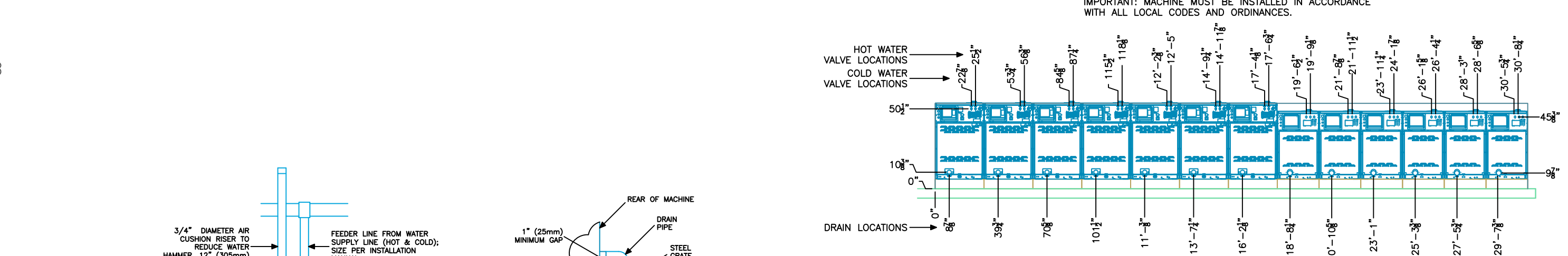

4A WASHER BANK 2 WATER/DRAIN LOCATIONS

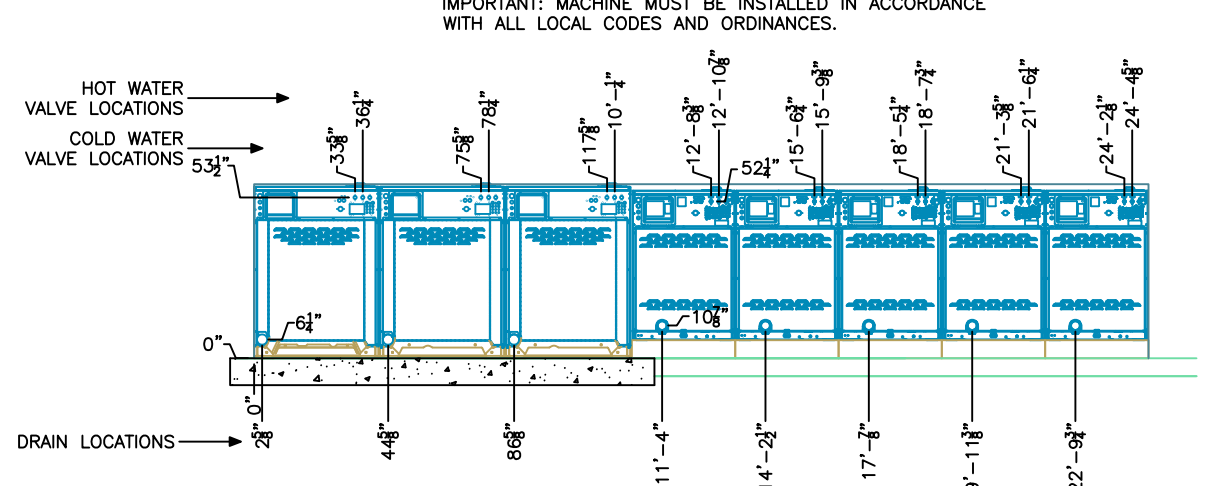

5A WASHER BANK 1 WATER/DRAIN LOCATIONS

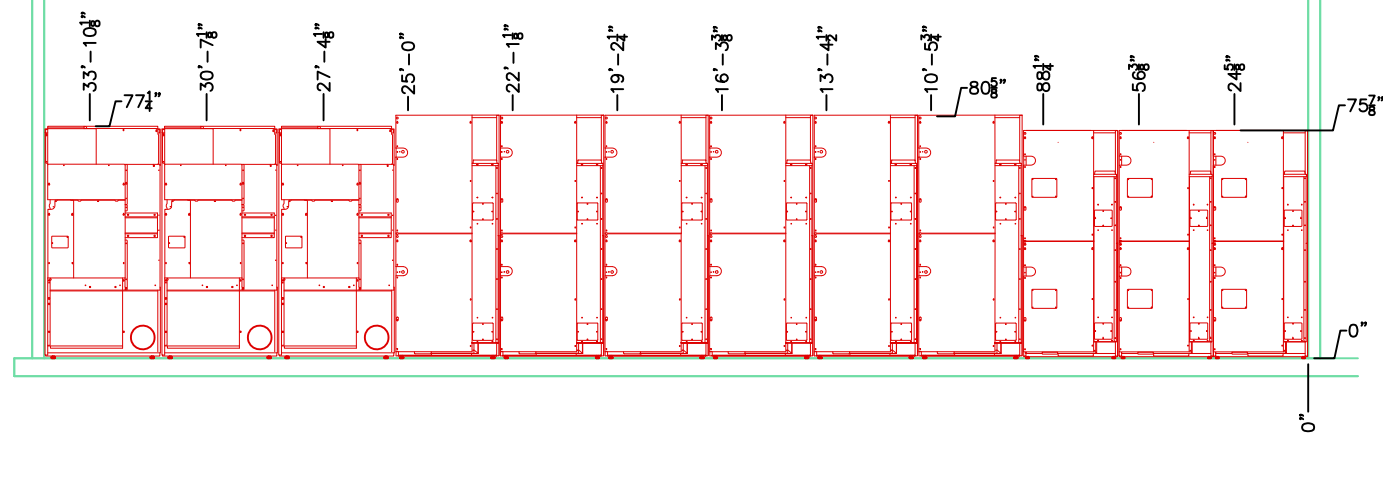

6A DRYER BANK NATURAL GAS VALVE LOCATIONS

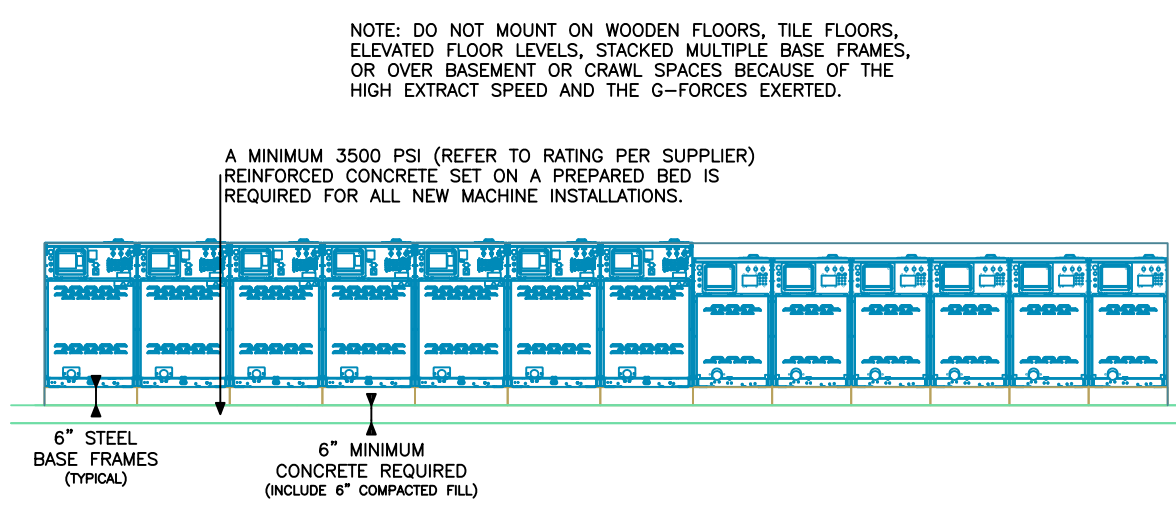
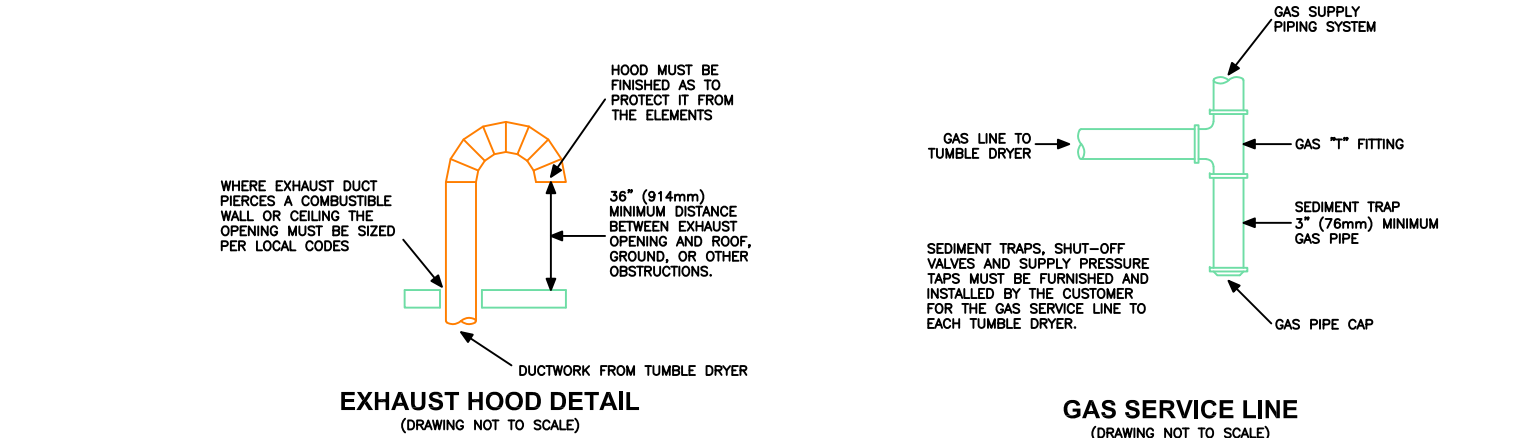
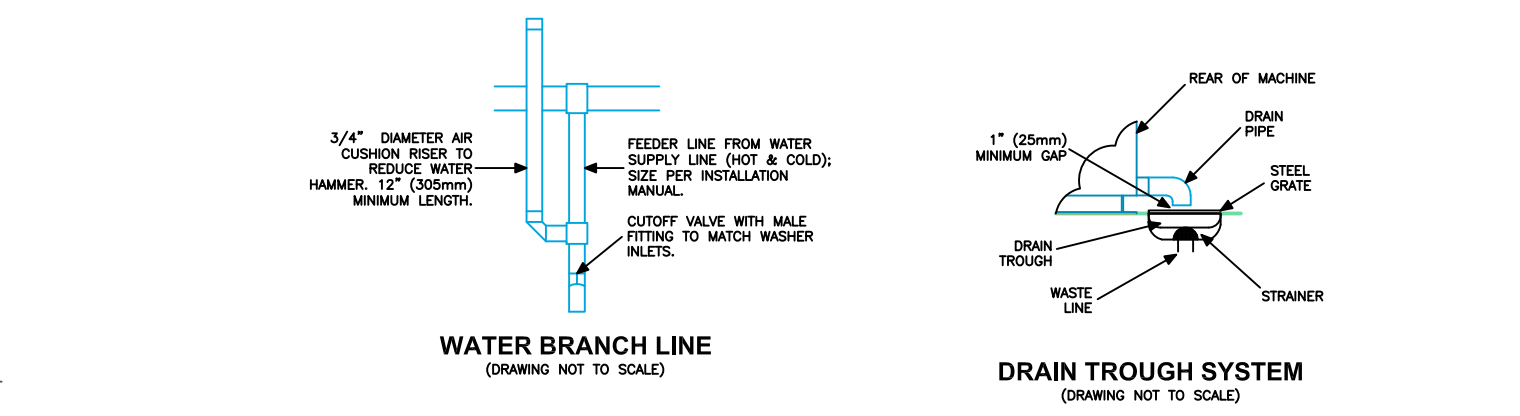

4B WASHER BANK 2 FOUNDATION SPECIFICATIONS

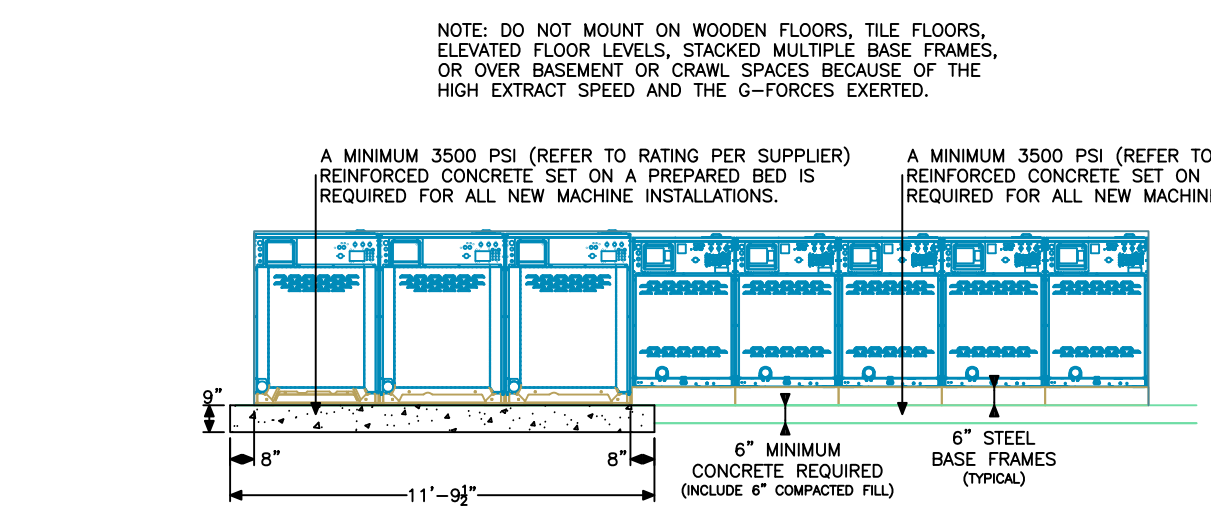

5B WASHER BANK 1 FOUNDATION SPECIFICATIONS

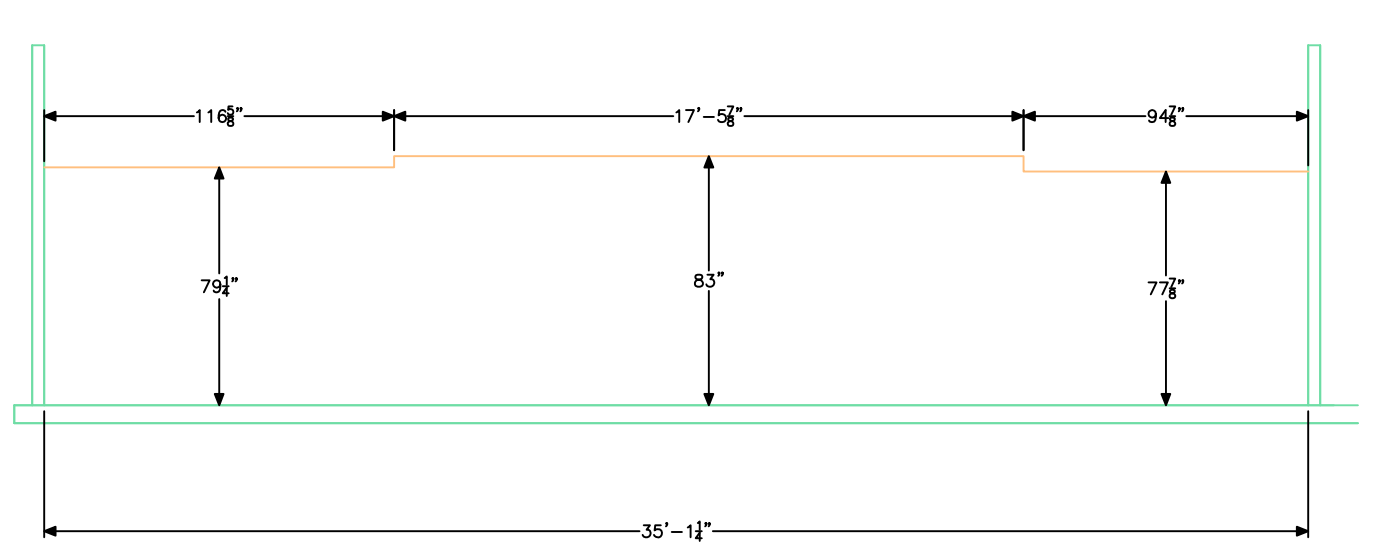

6B DRYER BANK TUMBLE DRYER OPENING MEASUREMENTS



PROJECT:
30441 EUCLID AVE

PROJECT NUMBER:
LDR-4412

AREA:
1625

EQUIPMENT DISTRIBUTOR:
Alliance Laundry
1 Shepard Street
Ripon, WI, 54971

DRAWN BY:
LAD

TITLE OF SHEET:
UTILITIES SPECIFICATIONS

SHEET NUMBER:
SHEET 3 OF 5

DATE:
8-Mar-23

NOT FOR CONSTRUCTION PURPOSES. Equipment specifications are subject to change without notice. Please see equipment installation manuals for updated equipment installation requirements.

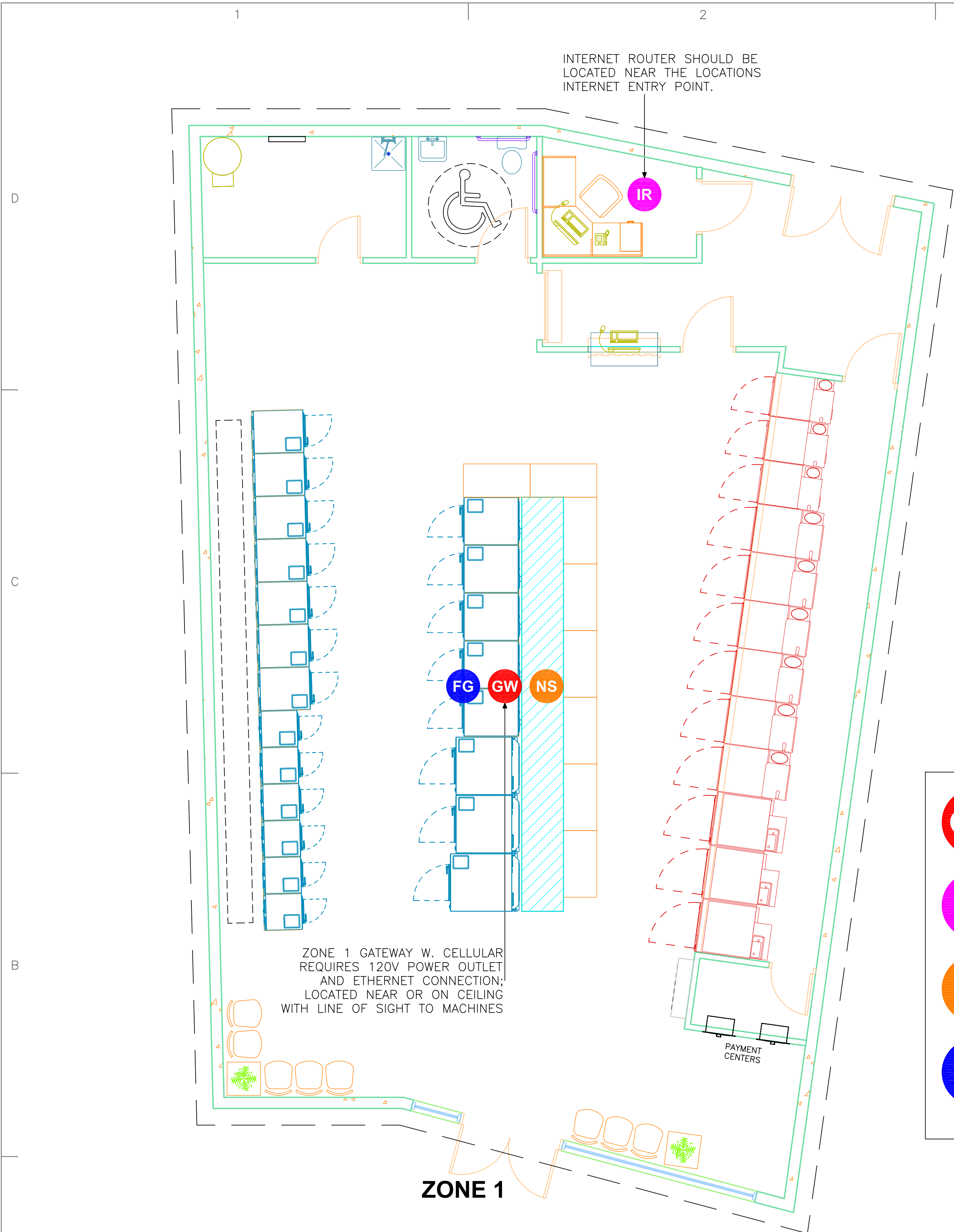

GW GATEWAY

IR INTERNET ROUTER

NS NETWORK SWITCH

FG FAILOVER GATEWAY

EQUIPMENT NEEDED:

- MACHINES WITH NETWORK BOARDS OR BUILT-IN CONNECTIVITY
- GATEWAY KIT(S)
- NETWORK SWITCH (FOR LOCATIONS WITH THREE OR MORE CELLULAR GATEWAYS)
- USB IR INTERFACE KIT
- ANDROID 6.0 (MARSHMALLOW) WITH INTERNET CONNECTION OR SPEED QUEEN QUANTUM PC SOFTWARE
- THE FACILITY MUST HAVE INTERNET ACCESS

NOTE:

GATEWAYS SHOULD NOT BE NEAR OTHER ELECTRICAL DEVICES (MICROWAVES, TVS, ETC.) AND SHOULD NOT BE PLACED BEHIND WALLS OR METAL BARRIERS. MAKE SURE ANTENNAS ARE POINTED DOWN IN DIFFERENT DIRECTIONS.

NOTE:

FOR 3 OR MORE GATEWAYS, A SINGLE ETHERNET CABLE SHOULD BE RUN FROM THE INTERNET ROUTER TO THE NETWORK SWITCH. FROM THE NETWORK SWITCH, ETHERNET CABLES WILL BE RUN TO GATEWAYS.

NOTE:

ETHERNET CONNECTION IS RECOMMENDED WHEREVER POSSIBLE FOR MAXIMUM RELIABILITY. FOR OPTIMAL PERFORMANCE, A BROADBAND INTERNET CONNECTION SPEED OF 10Mbps IS REQUIRED.

PRO TIP:

IT IS HIGHLY RECOMMENDED TO PUT THE GATEWAY POWER OUTLETS ON A SWITCH OR WI-FI SMART PLUG TO MAKE POWER CYCLING EASY.

**PLEASE CONTACT SOFTWARE SUPPORT FOR QUESTIONS.
EMAIL SOFTWARESUPPORT@ALLIANCELS.COM OR CALL 1-844-241-5519.**



PROJECT:	30441 EUCLID AVE
PROJECT NUMBER:	LDR-4412
AREA:	1625
EQUIPMENT DISTRIBUTOR:	Alliance Laundry 1 Shepard Street Ripon, WI, 54971
DRAWN BY:	LAD
TITLE OF SHEET:	NETWORKING SPECIFICATIONS
SHEET NUMBER:	SHEET 4 OF 5
DATE:	8-Mar-23

NOT FOR CONSTRUCTION PURPOSES. Equipment specifications are subject to change without notice. Please see equipment installation manuals for updated equipment installation requirements.



WATER CONNECTION NOTES

- THE MAXIMUM WATER INLET TEMPERATURE FOR VENDED MODELS IS 125°F (51°C) AND THE RECOMMENDED MAXIMUM WATER INLET TEMPERATURE FOR ON-PREMISES MODELS IS 150°F (66°C) (STANDARD MODELS) OR 140°F (60°C) (WRAS APPROVED MODELS).
- CONNECTIONS SHOULD BE SUPPLIED BY A HOT AND A COLD WATER LINES OF AT LEAST THE SIZES SHOWN IN THE INSTALLATION MANUAL. INSTALLATION OF ADDITIONAL MACHINES WILL REQUIRE PROPORTIONATELY LARGER WATER LINES.
- IF ADDITIONAL HOSE LENGTHS ARE NEEDED OR USING HOSES OTHER THAN THOSE SUPPLIED BY MANUFACTURER, FLEXIBLE HOSES WITH SCREEN FILTERS ARE REQUIRED.
- SUITABLE AIR CUSHIONS (RISERS) SHOULD BE INSTALLED IN SUPPLY LINES TO PREVENT "HAMMERING".
- ALLIANCE LAUNDRY SYSTEMS, LLC RANGES OF FRONT LOADING COMMERCIAL CLOTHES WASHING MACHINES HAVE SOLENOID VALVES AT THE INLETS. THE WATER SUPPLY TO THE WASHING MACHINES IS SUPPLIED WITH AN AB AIR GAP BETWEEN THE SOAP TRAY AND THE DRUM. MINIMUM AND MAXIMUM WORKING PRESSURE 1.4 bar AND 8.3 bar. THE MACHINES ARE SUPPLIED WITH APPROVED INLET HOSES WITH A MAXIMUM INLET DIMENSION OF 0.50" (15mm) (ID).
- NOTE: THE MACHINE HAS A FLUID CATEGORY 5 BACKFLOW PREVENTION DEVICE BUILT IN BETWEEN THE SOAP TRAY AND DRUM.
- NOTE: NO MORE THAN TWO WATER CONNECTION HOSES SHOULD BE USED ON WRAS-APPROVED MODELS.
- REFER TO INSTALLATION MANUAL FOR COMPLETE INSTALLATION PROCEDURES AND WATER CONNECTION REQUIREMENTS.

DRAIN CONNECTION NOTES

- IMPORTANT: MACHINES MUST BE INSTALLED IN ACCORDANCE WITH ALL LOCAL CODES AND ORDINANCES.
- ALL DRAIN SYSTEMS MUST BE VENTED TO PREVENT AIR LOCK AND TO PREVENT SIPHONING.
- USE THE SUPPLIED BLACK RUBBER ADAPTER AND CLAMPS TO TRANSITION FROM THE MACHINE DRAIN OUTLET TO THE 2" (51mm) SCHEDULE 40 PVC PLUMBING (20 AND 30 MODELS) AND THE 3" (76mm) SCHEDULE 40 PVC PLUMBING (40-100 MODELS).
- IF PROPER DRAIN SIZE IS NOT AVAILABLE OR PRACTICAL, A SURGE TANK IS REQUIRED. A SURGE TANK ALONG WITH A SUMP PUMP SHOULD BE USED WHEN GRAVITY DRAINAGE IS NOT POSSIBLE.
- INCREASING THE DRAIN HOSE LENGTH, INSTALLING ELBOWS, OR CAUSING BENDS WILL DECREASE DRAIN FLOW RATE AND INCREASE DRAIN TIMES, IMPAIRING MACHINE PERFORMANCE.
- REFER TO INSTALLATION MANUAL FOR COMPLETE INSTALLATION PROCEDURES AND DRAIN REQUIREMENTS.

ELECTRICAL NOTES

- IMPORTANT: ELECTRICAL RATINGS ARE SUBJECT TO CHANGE. REFER TO THE SERIAL DECAL FOR ELECTRICAL RATINGS INFORMATION SPECIFIC TO YOUR MACHINES.
- ELECTRICAL CONNECTIONS ARE MADE AT THE REAR OF THE MACHINE. THE MACHINE MUST BE CONNECTED TO THE PROPER ELECTRICAL SUPPLY SHOWN ON THE IDENTIFICATION PLATE ATTACHED TO THE REAR OF THE MACHINE, USING COPPER CONDUCTORS ONLY.
- MACHINES ARE EQUIPPED WITH AC INVERTER DRIVES REQUIRING A CLEAN POWER SUPPLY, FREE FROM VOLTAGE SPIKES AND SURGES. USE VOLTAGE MONITOR TO CHECK INCOMING POWER.
- SINGLE-PHASE MACHINES REQUIRE A SINGLE-PHASE INVERSE-TIME CIRCUIT BREAKER. THREE-PHASE MACHINES AND V-SPEED MACHINES REQUIRE A SEPARATE, THREE-PHASE INVERSE-TIME CIRCUIT BREAKER TO PREVENT DAMAGE TO THE MOTOR BY DISCONNECTING ALL LEGS IF ONE SHOULD BE LOST ACCIDENTALLY. REFER TO INSTALLATION MANUAL FOR MODEL SPECIFIC CIRCUIT BREAKER REQUIREMENTS.
- IMPORTANT: ALL QUICK DISCONNECTS SHOULD COMPLY WITH THE SPECIFICATIONS. DO NOT USE FUSES INSTEAD OF CIRCUIT BREAKERS.
- IMPORTANT: CONNECTION MUST BE MADE BY A QUALIFIED ELECTRICIAN USING WIRING DIAGRAM PROVIDED WITH MACHINE, OR ACCORDING TO ACCEPTED EUROPEAN UNION STANDARDS.
- CONNECT MACHINE TO AN INDIVIDUAL BRANCH CIRCUIT NOT SHARED WITH LIGHTING OR OTHER EQUIPMENT.
- FOR PERSONAL SAFETY AND PROPER OPERATION, THE MACHINE MUST BE GROUNDED IN ACCORDANCE WITH STATE AND LOCAL CODES. IF SUCH CODES ARE NOT AVAILABLE, GROUNDING MUST CONFORM TO THE NATIONAL ELECTRICAL CODE, ARTICLE 250 (CURRENT EDITION). THE GROUND CONNECTION MUST BE MADE TO A PROVEN EARTH GROUND, NOT TO CONDUIT OR WATER PIPES.
- ELECTRICALLY HEATED MACHINES DO NOT REQUIRE DUAL POWER SOURCES. DO NOT CONNECT CUSTOMER POWER OR CUSTOMER LOAD TO THE INTERNAL LOAD DISTRIBUTION TERMINAL BLOCK. REFER TO THE MACHINE ELECTRICAL SCHEMATIC FOR DETAILS.

ELECTRICAL NOTES

- ELECTRICAL CONNECTIONS MUST BE MADE BY A QUALIFIED ELECTRICIAN USING DATA ON A SERIAL PLATE, INSTALLATION MANUALS AND WIRING DIAGRAMS PROVIDED WITH MACHINE AND ACCORDING TO LOCAL CODES.
- INSTALL A CIRCUIT BREAKER AS CLOSE TO THE TUMBLE DRYER AS POSSIBLE. IF MORE THAN ONE TUMBLE DRYER IS BEING INSTALLED, A CIRCUIT BREAKER MUST BE PROVIDED FOR EACH.
- CONNECT MACHINE TO AN INDIVIDUAL BRANCH CIRCUIT NOT SHARED WITH LIGHTING OR OTHER EQUIPMENT.
- FOR 3 PHASE MACHINES ONLY – DO NOT USE FUSES TO AVOID THE POSSIBILITY OF "SINGLE PHASING" AND CAUSING PREMATURE FAILURE OF THE MOTORS.
- THE TUMBLE DRYER MUST BE GROUNDED. THE TUMBLE DRYER MUST BE CONNECTED TO A GROUNDED METAL, PERMANENT WIRING SYSTEM; OR AN EQUIPMENT GROUNDING CONDUCTOR MUST BE RUN WITH THE CIRCUIT CONDUCTORS AND CONNECTED TO APPROPRIATE GROUND LOCATION.
- FOR T30 AND T45 TUMBLE DRYERS ONLY:
 - ALL GAS AND STEAM TUMBLE DRYERS REQUIRE A SINGLE SERVICE CONNECTION TO TB1 OF THE UPPER UNIT JUNCTION BOX ONLY. THE SERIAL PLATE REFLECTS CURRENT DRAW, BREAKER/FUSE SIZE AND CONDUCTOR AMPERAGE REQUIRED FOR THE ENTIRE MACHINE.
 - ALL ELECTRIC TUMBLE DRYERS REQUIRE SEPARATE SERVICE CONNECTIONS FOR UPPER AND LOWER UNIT. SERIAL PLATE RATINGS REFLECT CURRENT DRAW, BREAKER/FUSE SIZE AND CONDUCTOR AMPERAGE REQUIRED PER UNIT.

FOUNDATION REQUIREMENTS

- A MINIMUM 3500 PSI (REFER TO RATING PER SUPPLIER) REINFORCED CONCRETE SET ON A PREPARED BED IS REQUIRED FOR ALL NEW MACHINE INSTALLATIONS.
- DO NOT MOUNT ON METAL BASE FRAMES, WOODEN FLOORS, TILE FLOORS, ELEVATED FLOOR LEVELS, OR OVER BASEMENTS OR CRAWL SPACES BECAUSE OF THE HIGH EXTRACT SPEED AND THE G-FORCES EXERTED. FOR 80 POUND MODELS AND LARGER, DO NOT MOUNT ON METAL BASE FRAMERS.
- FOR NEW FOUNDATIONS A MOUNTING BOLT TEMPLATE OR AN ELEVATED METAL BASE FRAME IS AVAILABLE AT EXTRA COST. FOR ALL INSTALLATIONS A CONCRETE HARDWARE KIT IS AVAILABLE AT EXTRA COST.
- THE MACHINE MUST BE ANCHORED TO A SMOOTH LEVEL SURFACE SO THAT THE ENTIRE BASE OF THE MACHINE IS SUPPORTED AND RESTS ON THE MOUNTING SURFACE.
- IMPORTANT: DO NOT PERMANENTLY SUPPORT THE MACHINE ON ONLY FOUR POINTS WITH SPACERS. GROUTING IS REQUIRED AND SPACERS MUST BE REMOVED.
- DO NOT ISOLATE THE PAD. THIS TYPE OF INSTALLATION IS NOT RECOMMENDED. INSTALLER MUST CONSULT A STRUCTURAL ENGINEER FOR CONCRETE SPECIFICATIONS AND REQUIREMENTS FOR INSTALLATIONS THAT WILL NOT BE TIED INTO ADJACENT FOUNDATIONS.
- THOROUGHNESS OF DETAIL MUST BE STRESSED WITH ALL FOUNDATION WORK TO ENSURE A STABLE UNIT INSTALLATION, ELIMINATING POSSIBILITIES OF EXCESSIVE VIBRATION DURING EXTRACT.
- REFER TO INSTALLATION MANUAL FOR COMPLETE INSTALLATION PROCEDURES AND FOUNDATION REQUIREMENTS.

EXHAUST NOTES

- WHENEVER POSSIBLE, INSTALL TUMBLE DRYERS ALONG AN OUTSIDE WALL WHERE DUCT LENGTH CAN BE KEPT TO A MINIMUM, AND MAKE-UP AIR CAN BE EASILY ACCESSED. CONSTRUCTION MUST NOT BLOCK THE AIRFLOW AT THE REAR OF THE TUMBLE DRYER. DOING SO WOULD PREVENT ADEQUATE AIR SUPPLY TO THE TUMBLE DRYER COMBUSTION CHAMBER.
- MAKE-UP AIR OPENINGS IN ROOMS CONTAINING TUMBLE DRYERS AND/OR GAS FIRED HOT WATER HEATERS OR OTHER GRAVITY VENTED APPLIANCES MUST BE INCREASED SUFFICIENTLY TO PREVENT DOWNDRAFTS IN ANY VENTS WHEN ALL TUMBLE DRYERS ARE IN OPERATION.
- DO NOT LOCATE GRAVITY VENTED APPLIANCES BETWEEN TUMBLE DRYERS AND MAKE-UP AIR OPENINGS. IF IT IS NECESSARY TO DUCT MAKE-UP AIR TO TUMBLE DRYERS, INCREASE AREA OF DUCT WORK BY 25% TO COMPENSATE FOR RESTRICTIONS IN AIR MOVEMENT.
- FOR MAXIMUM EFFICIENCY AND MINIMUM LINT ACCUMULATION, TUMBLE DRYER AIR MUST BE EXHAUSTED TO THE OUTDOORS BY THE SHORTEST POSSIBLE ROUTE.
- PROPER SIZED EXHAUST DUCTS ARE ESSENTIAL FOR PROPER OPERATION. ALL ELBOWS SHOULD BE SWEEP TYPE. EXHAUST DUCTS MUST BE ASSEMBLED SO THE INTERIOR SURFACES ARE SMOOTH, SO THE JOINTS DO NOT PERMIT THE ACCUMULATION OF LINT.
- THE MAXIMUM ALLOWABLE LENGTH VENTING IS 14' (4.3m) AND TWO 90° ELBOWS OR EQUIVALENT. IF THE EQUIVALENT LENGTH OF DUCT WORK REQUIRED FOR AN INSTALLATION EXCEEDS THE MAXIMUM ALLOWABLE LENGTH, THE DIAMETER OF A ROUND DUCT MUST BE INCREASE BY 10% FOR EACH ADDITIONAL 20' (6.1m). CROSS SECTION AREA OF A RECTANGULAR DUCT MUST BE INCREASED BY 20% FOR EACH ADDITIONAL 20' (6.1m).

DRYER ENCLOSURE NOTE

IT IS GENERALLY DESIRABLE TO ENCLOSE THE TUMBLE DRYERS TO SEGREGATE THE MAKE-UP AIR SUPPLY, ESPECIALLY IF THE LAUNDRY ROOM IS AIR CONDITIONED OR HAS SOME SORT OF ENVIRONMENTAL CONTROL. TUMBLE DRYER ENCLOSURES PROVIDE (2) SIGNIFICANT BENEFITS:

- THE TUMBLE DRYERS DO NOT USE CONDITIONED ROOM AIR FOR COMBUSTION MAKE-UP AIR. THIS MAKES OPERATING BOTH THE ENVIRONMENTAL SYSTEM AND THE TUMBLE DRYERS LESS EXPENSIVE BECAUSE AIR THAT IS COOLED TO 75°F (24°C) IS NOT TAKEN FROM THE ROOM AND REHEATED TO 160°-180°F (71-82°C).
- HEAT EMISSIONS FROM THE TUMBLE DRYERS ARE REDUCED UP TO 80%. EACH EXPOSED FACE WILL EMIT 2% OF THE RATED BTU INPUT. IF A TUMBLE DRYER IS NOT ENCLOSED, THERE ARE FIVE FACES EXPOSED, SO THE HEAT EMITTED IS 5 x 0.02 x RATED BTU INPUT, OR 10%. IF ENCLOSED, ONLY ONE FACE IS EXPOSED.

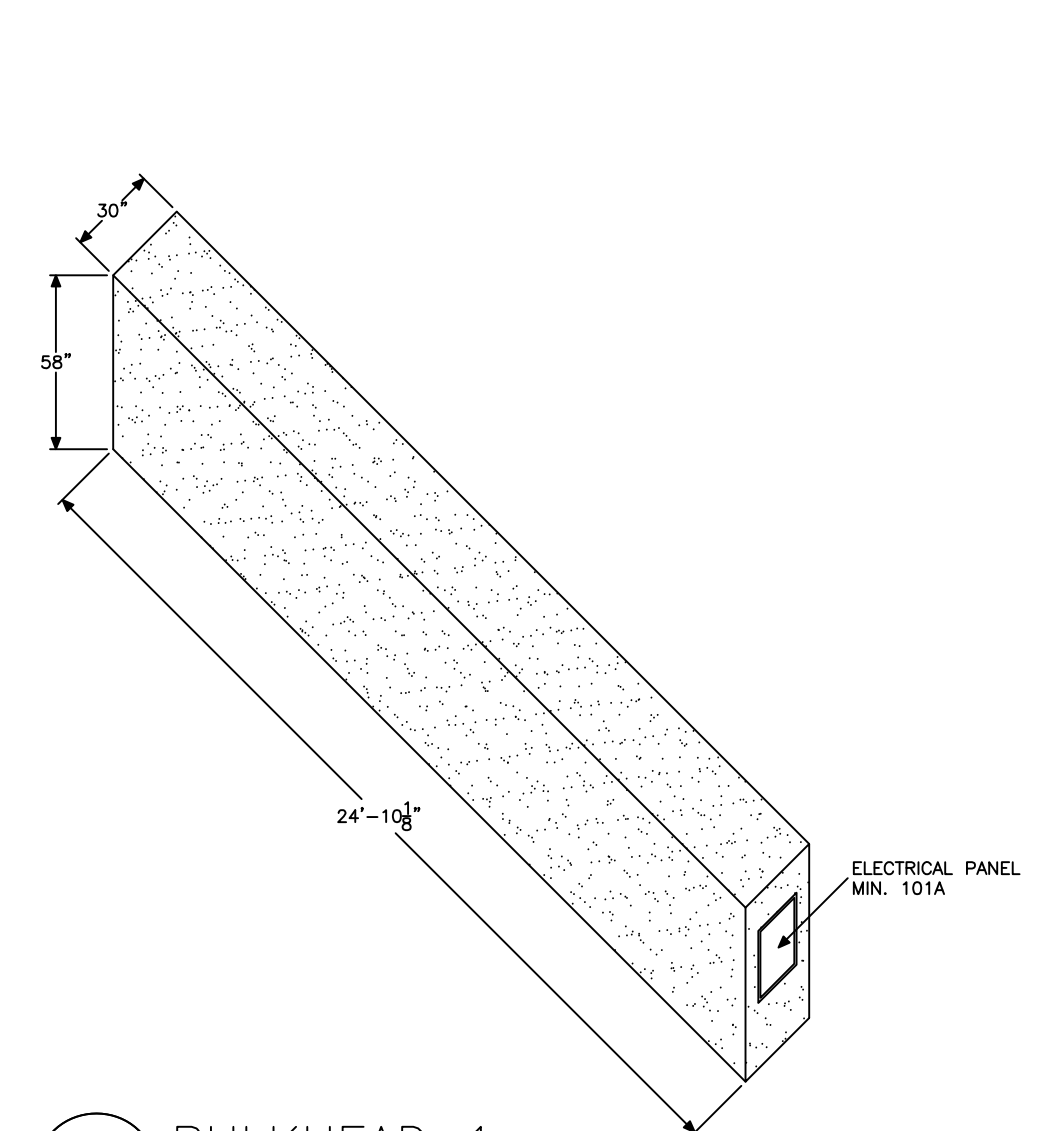

B1 BULKHEAD 1 WASHER BANK 1

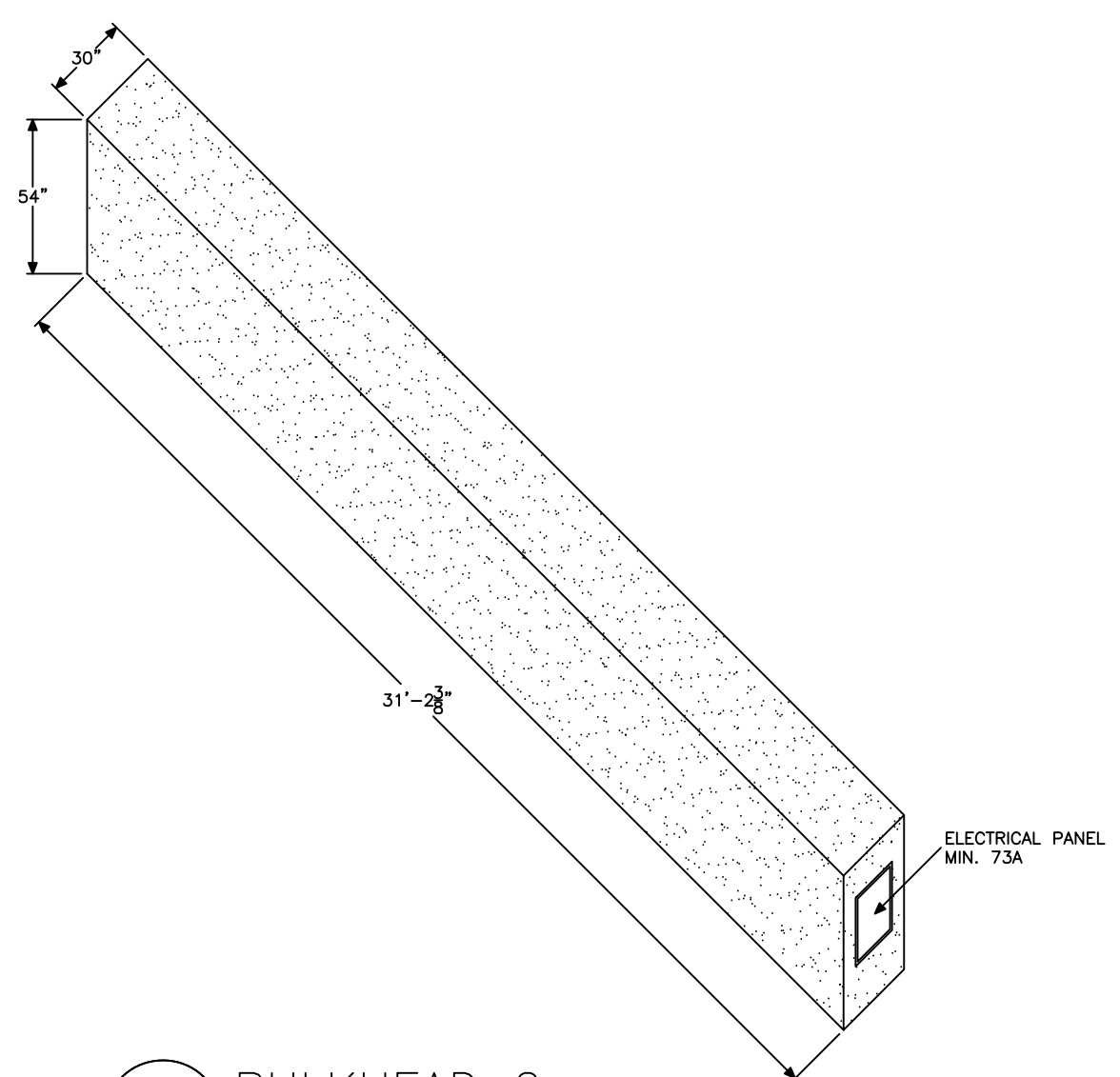

B2 BULKHEAD 2 WASHER BANK 2

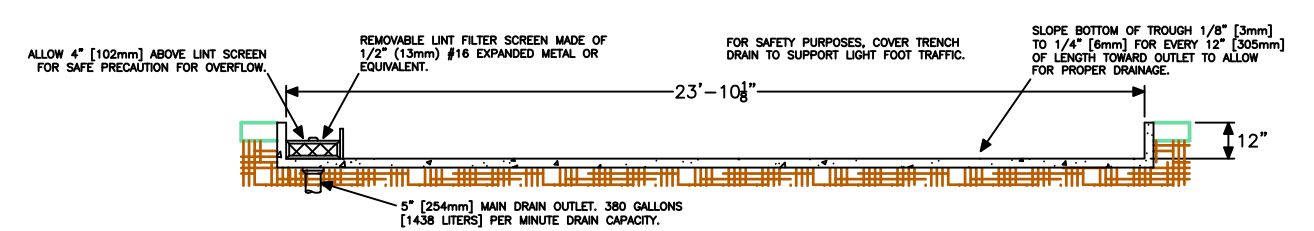

TD1 TROUGH DRAIN 1 WASHER BANK 1

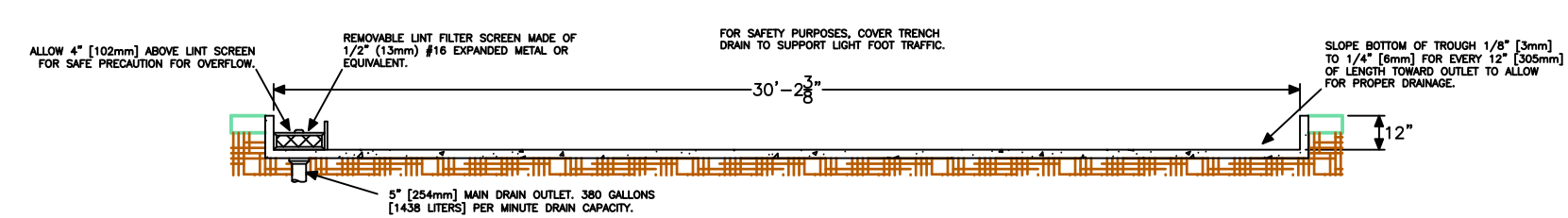

TD2 TROUGH DRAIN 2 WASHER BANKS 2

H.V.A.C. NOTE

A LICENSED HEATING, VENTING AND AIR CONDITIONING (HVAC) FIRM SHOULD BE CONSULTED TO ENSURE A PROPER VENTING SYSTEMS IS INSTALLED. IMPROPERLY SIZED OR INSTALLED EXHAUST DUCTWORK CAN CREATE EXCESSIVE BACK PRESSURE WHICH RESULTS IN SLOW DRYING, INCREASE USE OF ENERGY, OVERHEATING OF DRYER AND CAN CREATE A POTENTIAL FIRE HAZARD.

MATERIALS REQUIRED (GAS)

(OBTAIN MATERIALS REQUIRED LOCALLY)

- FUSED DISCONNECT SWITCH OR CIRCUIT BREAKER ON 1 PHASE MODELS. CIRCUIT BREAKER ON 3 PHASE MODELS.
- ONE GAS SHUT-OFF VALVE FOR GAS SERVICE LINE TO EACH TUMBLE DRYER.

GAS NOTES

- OBTAIN SPECIFIC GAS SERVICE PIPE SIZE FROM GAS SUPPLIER. REFER TO INSTALLATION/MAINTENANCE MANUAL FOR GENERAL PIPE SIZE.
- SEDIMENT TRAPS, SHUT-OFF VALVES, AND SUPPLY PRESSURE TAPS MUST BE FURNISHED BY THE CUSTOMER FOR THE GAS SERVICE LINE TO EACH TUMBLE DRYER.
- IT IS IMPORTANT THAT EQUAL PRESSURE BE MAINTAINED AT ALL TUMBLE DRYER GAS CONNECTIONS. THIS CAN BE DONE BY INSTALLING A 1" (25.4mm) PIPE GAS LOOP TO MAINTAIN EQUAL PRESSURE AT ALL GAS CONNECTIONS.
- AN IN-LINE PRESSURE REGULATOR MAY BE REQUIRED IF THE LINE PRESSURE EXCEEDS 10.5 W.C.I. (26.1mbar, 2.61kPa) WITH ALL GAS APPLIANCES RUNNING.
- FOR PROPER OPERATION AT ALTITUDES ABOVE 2000' (610m), THE GAS BURNER ORIFICE SIZE MUST BE REDUCED TO ENSURE COMPLETE COMBUSTION.
- REFER TO INSTALLATION/MAINTENANCE MANUAL FOR COMPLETE INSTALLATION PROCEDURES AND GAS REQUIREMENT INFORMATION.



PROJECT:
30441 EUCLID AVE

PROJECT NUMBER:
LDR-4412

AREA:
1625

EQUIPMENT DISTRIBUTOR:
Alliance Laundry
1 Shepard Street
Ripon, WI, 54971

DRAWN BY:
LAD

TITLE OF SHEET:
BULKHEAD
DETAILS & NOTES

SHEET NUMBER:
SHEET 5 OF 5

DATE:
8-Mar-23

NOT FOR CONSTRUCTION PURPOSES. Equipment specifications are subject to change without notice. Please see equipment installation manuals for updated equipment installation requirements.