

Rik Kowall, Supervisor
Anthony Noble, Clerk
Mike Roman, Treasurer



Trustees
Scott Ruggles
Michael Powell
Andrea C. Voorheis
Liz Fessler Smith

WHITE LAKE TOWNSHIP DEPARTMENT OF PUBLIC SERVICES

7525 Highland Road, White Lake, Michigan 48383-2900, (248) 698-7700, www.whitelaketwp.com

May 26, 2022

Honorable Board of Trustees
Charter Township of White Lake
7525 Highland Road
White Lake, MI 48383

RE: DPS/Maintenance Truck Purchase

Dear Board of Trustees:

For the past several years the Township has used the salt spreader mounted onto the 2012 Ford F-250 pickup for salting the Township facilities. The spreader that we currently have has a one-yard load capacity. With the weight of the spreader and one yard of rock salt we are right at the maximum weight capacity for the current truck. We use approx. 3 yards on average to salt all of the Township facilities. This results in three trips to get salt per snow event at around 1 hour each round trip with loading time. This has resulted in a lot of overtime in maintenance. In the past in order to cut this down they have overloaded the truck. I suspect that this was partly to blame for the early demise of the other F-250 that was replaced in 2017.

DPS has a desire to increase our ability to do work in house rather than outsource. We have discussed having some ability to complete property restorations and other property maintenance.

We have determined that a 3-yard dump truck would be the most versatile vehicle DPS has contacted several dealerships/websites since March looking for a truck, truck chassis or dump truck that we can outfit for the township needs.

Every time we think we have found a viable option; we are told that it has already been sold. Trucks are only lasting 1-2 days on a lot. Our procurement policy does not allow us to work fast enough to find the vehicle we need in today's supply chain shortages and demands. We have received several quotes but have not had enough time to secure a deposit before they are sold.

DPS would like the Township Board to approve a budget not to exceed \$110,000 and approve DPS to work directly with the Clerk to purchase this vehicle through his contacts. This would be a general fund purchase for the Maintenance Department. Time used for this vehicle by other funds such as water or sewer would be invoiced to those departments.

In addition to the 3-yard dump, the Maintenance branch is in need of one additional vehicle for the custodian. Currently our custodian is using his own vehicle to do his work for the Township which I feel is not appropriate. I would like to equip him with a Ford Transit Connect or similar class vehicle which would be stocked with PPE, supplies, and the tools that he uses for his duties so that he has what he needs for his job. He should not have to put wear and tear on his personal vehicle and pay for gas for Township use. He is not compensated for this and it will be an accounting nightmare to keep track of all of that.

DPS would like the Township Board to approve a budget not to exceed \$\$35,000.00 and approve DPS to work directly with the Clerk to purchase this vehicle through his contacts. This would be a general fund purchase for the Maintenance Department. Time used for this vehicle by other funds such as water or sewer would be invoiced to those departments.

Please feel free to contact me if you have any questions.

Sincerely,

A handwritten signature in black ink that reads "Aaron Potter". The signature is written in a cursive, flowing style.

Aaron D. Potter
Director, Dept. of Public Services
Charter Township of White Lake

Henderson

MARK III

Utility-sized Dump Body for Unsurpassed Versatility

The Henderson **MARK III** is living proof that you don't need to sacrifice rugged, heavy-duty service just because you don't need a behemoth dump truck. It is designed for the customer who needs a utility-sized body.

It has the same rugged features as its bigger relatives. Features like: unibody design with a one-piece floor joined by a radius to the sides with a continuous weld, cross-memberless under-structure to prevent washboarding; exclusive trunnion-mounted telescopic hoist for enormous lifting power, shorter cycle time and reduction of sway; double-walled tailgate and a 9" mounting height for a lower center of gravity and increased stability.

But that is not all. The **MARK III** is styled to look better longer through outward sloped rails that shed dirt and debris. All welds are continuous seams to add rigidity and to prevent water infiltration. And much more from...

The Dependable Ones™



- Head sheet has two built-in windows to provide a better view for backing up or checking on a load while protecting the cab widow.
- Cab shield is an integral part of the head sheet and has streamlined end plates to eliminate sharp edges.
- The nitrided, trunnion-mounted telescopic hoist provides superior lift capacity and faster cycle time
- Quick-release handles on the sides give you instant side release from a single point-of-use. Latch is positive cam-action **OPTIONAL** on the tailgate.
- Includes electric gear pump with reservoir, hydraulic plumbing, electric push-button hoist control and mounting hardware.
- Five-inch structural I-beam longitudinals provide support instead of the traditional cross-members known to cause wash boarding problems.
- One-piece, double-walled fixed side panels with boxed top rail strengthen the body to prevent it from twisting. Panels stay better looking longer. Rail edges have a soft contour to resist paint chipping.
- All top rails and rub rails slope outward to shed debris.
- Unibody design features a 3/16", one-piece, seamless floor with formed 2" floor-to-side radius. The low 9" mounting height increases stability and accessibility.
- Full-depth rear corner posts tied to 5" structural channel rear apron.
- Stop/turn/tail light mounted in reach rear corner post with side clearance light and reflectors.
- Double-walled, double-acting tailgate with full perimeter boxing. Flame-cut latches are mounted to reinforce plates that overlap the rear corner post and apron to prevent spreading of sides.
- Shock resistant stop/turn/tail lights and I.C.C. light cluster are provided with a one-piece sealed wiring harness.
- The rear hinge assembly built tough to resist twisting. 1-1/4" diameter pins connect through 4" hinge bushings.
- Premium hoist control for electric/hydraulic power unit. Shock-resistant case affords long life.

UTILITY DUMP BODIES

MARK III DIMENSIONS AND CAPACITY CHART

LENGTH	WIDTH		HEIGHT			CAPACITY			TYPE CLASS	CLASS (NTEA)	HOIST	
	INSIDE	OUTSIDE	SIDES	TAILGATE	HEAD	APPROX. WEIGHT (lbs)	SIDES/ENDS (cu. yd.)	w/SIDEBOARDS (cu. yd.)			NTEA RATED CAPACITY Tons @ Critical Angle	CAPACITY Tons @ Liftoff
8'	85"	95"	13"	19"	42"	1528	2.3/3.3	5.3	M-80-3.5-3	20	12.7 @ 39.1°	19.4
8'	85"	95"	18"	24"	42"	1645	3.2/4.2	5.9	M-80-3.5-3	20	12.7 @ 39.1°	19.4
9'	85"	95"	13"	19"	42"	1640	2.5/3.7	6.0	M-80-3.5-3	20	9.5 @ 34.6°	19.1
9'	85"	95"	18"	24"	42"	1753	3.5/4.7	6.5	M-80-3.5-3	20	9.5 @ 34.6°	19.1
10'	85"	95"	13"	19"	42"	1710	2.8/4.2	6.6	M-80-3.5-3	20	7.3 @ 29.8°	18.9
10'	85"	95"	18"	24"	42"	1829	3.9/5.3	7.2	M-80-3.5-3	20	7.3 @ 29.8°	18.9
11'	85"	95"	13"	19"	42"	1829	3.4/4.6	7.3	M-80-3.5-3	20	5.5 @ 33.4°	18.6
11'	85"	95"	18"	24"	42"	1933	4.3/5.8	7.9	M-80-3.5-3	20	5.5 @ 33.4°	18.6

UNIBODY DESIGN

One-piece floor with 2" formed radius to join sides. Full-depth rear corner posts tied to 5" structural channel rear apron. Smooth under structure has 5" structural steel I-beam longitudinals with no cross-members and a low 9" mounting height.

HOIST

Three-stage telescopic, trunnion-mounted hoist with nitrided cylinder tubes. Hydraulic plumbing and electric push button hoist included. Two-year warranty.

MOUNTING

- Low 9" mounting height
- Full sub-frame cradle and rear hinge assembly built in for quick installation
- Includes premium in-cab control, electric gear pump/reservoir, and mounting hardware

FLOOR

- One-piece, 3/16" steel
- 2" formed in floor-to-side radius
- 5" x 10.0 lbs./ft I-beams longills with no cross-members

SIDES

Double-wall, 12-gauge steel with sloped, formed top rail.

HEADSHEET

12-gauge steel with integral cab shield and two pre-punched windows. (Varying cab shield heights available to optimize fit on different brands of chassis.)

TAILGATE

- One-piece 12-gauge steel.
- Double-wall sheet with full perimeter boxing and sloped top rail.
- Flush-mount, off-set tailgate hinge plates with easy-release pins.
- 1" top and 1-1/4" bottom latch pins.
- Manual over-center tailgate release mechanism with rubber covered handle.

LIGHT PACKAGE

- Stop/turn/tail lights are mounted in rear corner post.
- I.C.C. and rear clearance lights with reflectors are also included.
- All lights are rubber mounted, shock resistant and feature one-piece sealed wiring harness.

BODY PREPARATION

- Entire body is chemically cleaned with a phosphate solution before being primed.
- Primed with high-quality primer.

OPTIONS

- Aerodynamically contoured, tapered headsheet has integral cab shield.
- Headsheet without integral cab shield
- 304 Stainless steel body construction
- One-piece, 12-gauge sloping side boards
- Quick-release, fold-down sides features sloped surface to shed debris.
- Quick-release, drop-down tailgate.
- Coal chute.
- Direct mount PTO pump.
- L.E.D. light kit
- 1st Stage Power Down Cylinder



OPTIONAL contoured, tapered headsheet is aerodynamically shaped to complement the new cab designs and increase visibility.

OPTIONAL quick-release, fold-down sides and convenience. The sturdy hinge is positioned beneath the body, oft of the way of falling debris. Sloped surfaces on the sides and floor help shed debris during dumping.

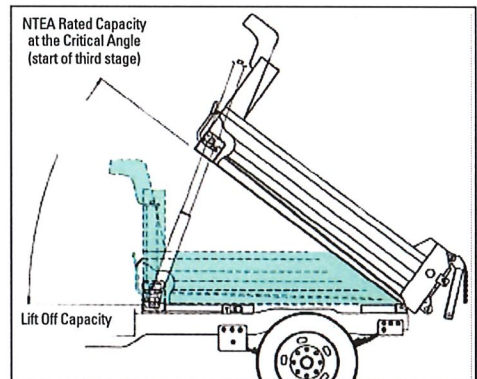

Illustrated above are the NTEA Capacity and Liftoff Capacity point of measure for the hoist.

COMPLETE MUNICIPAL SNOW & ICE CONTROL SOLUTIONS

PLOWES • WINGS • UNDERBODY SCRAPERS • SAND & SALT SPREADERS • STANDARD & PRECISION SPINNERS • DUMP BODIES • COMBINATION (MUNICIPAL) BODIES
BRINE PRODUCTION & MANAGEMENT SYSTEMS • ANTI-ICE SYSTEMS • PRE-WET SYSTEMS • SLURRY SYSTEMS • COMPLETE TURNKEY PACKAGES



© Henderson Products, Inc., A Division of Douglas Dynamics, L.L.C., reserves the right in pursuit of continuous product improvement to change specifications used herein. As a custom manufacturer of truck bodies, truck equipment and brine systems, additional product options may be available that are not shown here.



1085 S. Third Street, Manchester, IA 52057
Toll Free: (800) 359-4970
www.HendersonProducts.com

Sourcewell CONTRACT: 080818-HPI



Henderson

RTS

Mild or Stainless Steel...for Peerless Performance Under All Conditions

The Henderson RTS - Replacement Tailgate Spreader is the new standard. The RTS is designed to fit most one-ton dump bodies including bolting right on the Henderson line of Mark III and Mark IV dump bodies.

Henderson used many of the TGS spreader features in the RTS design, providing the best value spreader in the industry. The RTS; built to a higher standard.



- Designed to replace tailgate on most 2-3 yard dump bodies including the Mark III and Mark IV.
- 6" auger and agitator allows for continuous material flow.
- Quick release bottom closure for fast and easy clean out.
- Center lift loop point for easy installation and removal.

- Hydraulic safety interlock prevents bottom closure from being opened without disengaging hydraulics.
- Available in mild steel (painted orange) or stainless steel (unpainted).
- A polyurethane hub is utilized at both ends of the auger to eliminate seizing and ensure ease of maintenance.

- Direct drive auger motor.
- Spinner remains level without the need for a stabilizer bar.
- 18" diameter polyurethane spinner disc with six formed fins.
- Lift hook provided on top of unit.

The Dependable Ones

REPLACEMENT TAILGATE SPREADER

SPECIFICATIONS

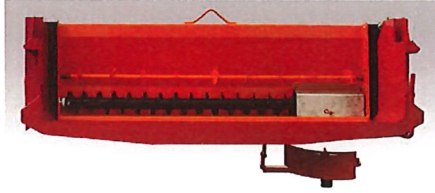

AUGER / AGITATOR

- 6" direct drive auger with "paddle type" agitator for continuous smooth material flow
- 1-1/4" auger shaft utilizes a polyurethane hub at both ends to eliminate corrosion and for ease of maintenance
- Stainless steel anti-flow plate is standard on mild steel and stainless steel units

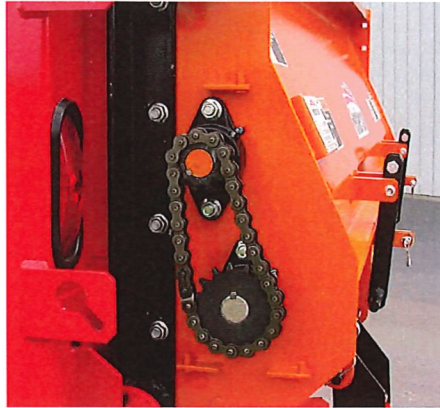

SAFETY SYSTEM

- A hydraulic safety interlock system is built into the unit to provide maximum protection for the operator.
- Hydraulics must be disconnected to open bottom cleanout door



AGITATOR SHAFT

- 1-1/4" agitator drive shaft is driven off the auger with #60 roller chain.
- A chain guard covers the agitator drive systems and is easily removed without tools.

HOPPER / TROUGH

The full width hopper has a bottom cleanout door which utilizes two release handles and a quick disconnect safety interlock for fast and easy cleanout. Backplate of hopper trough and bottom cleanout door is 7 gauge steel, endplates are 1/4". All seams are continuous welded.

AUGER / AGITATOR

The 3/8" heavy duty thick auger flighting is welded to a 2-1/2" Schedule 40 pipe. The auger is supported by a 1-1/4" shaft utilizing polyurethane hubs at both ends to eliminate corrosion and for ease of maintenance. The 1-1/4" agitator shaft is driven off the auger with #60 roller chain. The agitator utilizes a "paddle" design which in combination with the 6" auger helps to insure constant material flow. The agitator shaft is supported at both ends with sealed, self-aligning ball bearings. Anti-flow plate is provided to prevent loss of free flowing material while auger is stopped.

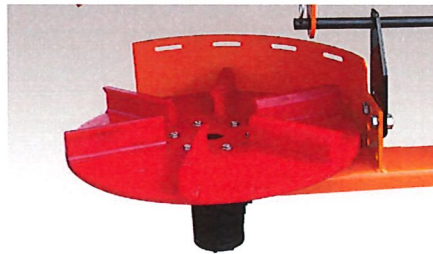

SPINNER ASSEMBLY

Polyurethane spinner disc is 18" in diameter with six formed fins. The spinner assembly is mounted on the left end of the hopper. Spinner is direct driven by a 2.8 C.I.R. hydraulic motor mounted beneath the spinner disc. The spinner assembly is adjustable both horizontally and vertically, which allows for changes in spread pattern and for different chassis heights, a Henderson exclusive. The spinner assembly is self-leveling regardless of dump body angle without the need for a stabilizer bar. This protects the spinner assembly if the driver backs into an obstacle. A stationary shield in front of the spinner protects the undercarriage from thrown material.

MOUNTING

The RTS has mounting kits designed to make installation and removal a snap. A center lift point is included for easy installation and removal.

OPTIONS

- Adjustable baffle to direct spread
- Dual flow control valve
- Hoses, fittings & couplers
- 20 gallon hydraulic reservoir with filter, sight / temperature gauge and mounting brackets



OPTIONAL: Stainless Steel units available (unpainted)

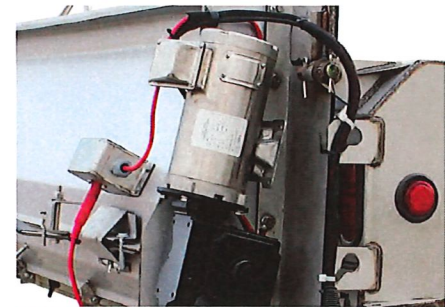

OPTIONAL: 3/4hp electric motor with Stainless Steel housing (unpainted)

HENDERSON PRODUCTS INC. ALSO PROUDLY OFFERS THESE INNOVATIVE PRODUCTS:

- Reversible Plow
- One-Way Plow
- Reversible One-Way Plow
- Leveling Wing
- Mid-Mount Wing
- V-Box Sand and Salt Spreader
- Tailgate Sand and Salt Spreader
- Pre-Wet Systems
- Full line of Mark Series dump bodies for single- and tandem-axle trucks
- Underbody Scraper
- Munibody™ combination dump/spreader bodies
- Patrol Control™ - Complete hydraulic control systems

COMPLETE MUNICIPAL SNOW & ICE CONTROL SOLUTIONS

PLOWS • WINGS • UNDERBODY SCRAPERS • SAND & SALT SPREADERS • STANDARD & PRECISION SPINNERS • DUMP BODIES • COMBINATION (MUNICIPAL) BODIES
BRINE PRODUCTION & MANAGEMENT SYSTEMS • ANTI-ICE SYSTEMS • PRE-WET SYSTEMS • SLURRY SYSTEMS • COMPLETE TURNKEY PACKAGES



© Henderson Products, Inc., A division of Douglas Dynamics, L.L.C., reserves the right in pursuit of continuous product improvement to change specifications used herein. As a custom manufacturer of truck bodies, truck equipment and brine systems, additional product options may be available that are not shown here.



1085 S. Third Street, Manchester, IA 52057
Toll Free: (800) 359-4970
www.HendersonProducts.com

Sourcewell 
CONTRACT: 080818-HPI



HP-071 05/20



Knapheide Truck Equipment - Flint
 1200 S. Averill Ave.
 Flint MI 48503
 Phone: 810-744-0295
 Fax: 855-629-4643
 www.flint.knapheide.com

QUOTATION

Quote ID: KD00002577
 Page 1 of 3

Customer: WHITE LAKE TOWNSHIP
 7525 HIGHLAND ROAD
 WHITE LAKE MI 48383-2900

Quote Number: KD00002577
Quote Date: 2/21/2022
Quote valid until: 3/23/2022

Contact: AARON POTTER 248-505-8528
 Phone: 248-698-3300
 Fax: 1-248-698-3996

Prepared kdennison
By:
Salesperson: NATE TOMALIA
PO#:

Enduser:

Make:	Model: 3500 CHASSIS CAB	Year:	Single/Dual: DRW
Cab Type:	Wheelbase:	Cab-to-Axle: 60.0	VIN:

QTY	PART NUMBER	DESCRIPTION	AMOUNT
1	HEND MK3	9' 201SS MK3 QUOTE 158978-6: DESCRIPTION: DB3 9' body length 13" side height / 19" tailgate height 2.5/3.7 yd Telescopic hoist, trunion mount (Req's Min 2000 PSI) Body Size / Style Body Length: 9' body length Side / Tailgate Height: 13" side height / 19" tailgate height 2.5/3.7 yd Hoist Type: Telescopic hoist, trunion mount (Req's Min 2000 PSI) Hydraulics Hoist Cylinder: CS 85-4.5-3 double acting cylinder ILO standard Install Cylinder and Subframe: No Pump Pack: None - deduct standard pump pack Sides / Ends / Floor Side Construction: Double Wall 12 ga FIXED Sides Optional Sides/Ends Materials: 201SS sides and ends Optional Floor Materials: 3/16" AR400 floor ILO std grade 50 Sloped Steel Side Boards: No Tailgate Options Tailgate Style: Standard Dump Tailgate-Requires Pin Removal for Lay Down Coal Chute: No Light Options Front Amber Marker Lights: No LED Light Kit ILO Standard:(Includes one-piece wiring harness) Cabshield Options Headsheet Type: Straight headsheet with integral 53" cabshield clearance Integral Cabshield Notice: !!!DEALER TO VERIFY CHASSIS CAB CLEARANCE PRIOR TO ORDER!!! Custom Options Option 1: 24in. tailagte ILO 19in. Option 2: 2 rear facing obround light holes in each corner post IMPORTANT NOTE FROM HENDERSON MFG Due to the current raw material market conditions Henderson Products is forced to put a Surcharge in place on Henderson equipment. Quote exceeding the expressed quote validity date are subject to surcharge revisions. HENDERSON QUOTE DATES Quote-Issued Date: 2/16/2022 Quote Valid Until Date: 3/18/2022	



Knapheide Truck Equipment - Flint
 1200 S. Averill Ave.
 Flint MI 48503
 Phone: 810-744-0295
 Fax: 855-629-4643
 www.flint.knapheide.com

QUOTATION

Quote ID: KD00002577

Page 2 of 3

QTY	PART NUMBER	DESCRIPTION	AMOUNT
1	HEND TGS966DD-201	HENDERSON SALT SPREADER 201SS QTE 158979-4 96" LONG, 6" AUGER, DIRECT DR.	
1	CT HYD	HYD PKG FOR DUMP / SPREADER	
1	HOSES	HYDRAULIC HOSE AND FITTINGS	
1	PION LNDSCCK14PB KIT	PIONEER MANUAL ECONOMY TARP 8'-11' MESH W/DELUXE HDWE	
2	STAR DLXTHUS-4-AG	HENDERSON SUPPLIED STT LIGHTS IN BOTTOM HOLE OEM BACKUP LIGHT INSTALLED NEXT TO HITCH 6" OVAL AMBER/GREEN STROBE INSTALL IN TOP HOLE ALL STROBES WIRED TO SAME OEM UPFITTER SWITCH / KEY HOT	
2	PETE 421-18	6" OVAL GROMMET	
1	NAMR LB4	SELF LEVELING BRACKET MOUNT CENTER ON CABSHIELD	
1	ECCO 5590CAG	LED 15" MINIBAR GREEN/AMBER MOUNT ON LEVELING BRACKET	
1	ECCO ED3712AG	LED SURFACE MOUNT DIRECTIONAL AMBER/GREEN MOUNT IN GRILL UP HIGH	
1	MUD FLAPS	RUBBER MUD FLAPS - PAIR.	
2	JAS MUD FLAP BRACKET	MUD FLAP BRACKET PER PRINT	
2	BUYE 405BC	BRACKET ANTI-SAIL CHROME	
1	BUYE 1809030B	PINTLE PLATE WITH D-RINGS & ICC CHANNEL	
1	BUYE BH82516	COMBINATION BOLT ON PINTLE HITCH WITH 2-5/16" BALL	
2	TERM TG-6370-H	TAIL LIGHT EXTENSION REQ W/HITCH OR ICC	
1	POLL 11-893P	OEM-STYLE 7-WAY "RV" TRAILER PLUG.	
1	TERM TG-6370-068	FORD ADAPTER 7 WAY	
1	POLL 41-820	12 VOLT ELECTRIC BACK-UP ALARM	
1	WS 9.5 MVP3 MS	Western MVP3 9'6" Steel V-Plow; 8'6" Blade Width, 39"H Blade Height (at end), 31"H Blade Height (at hinge), 14-Gauge Steel Blade, 6-Trip Springs, 0-Shock Absorbers, 8-Vertical Ribs, 1-3/4" x 11" Angling Rams, 8'6" Plowing Width Full-Angle, 8'2" Plowing Width Full-Scoop, 8'7" Plowing Width Full-V, 0-Cast Iron Disc Shoes, 1,022-lbs. Approximate Weight (less-mount), 1/2" x 6" Cutting Edge, Includes lights, blade guides, Cab Command hand-held control and snow deflector. Installed; F.O.B. Flint, MI.	

Quote Total:	\$39,632.18
Sales Tax not included	



Knapheide Truck Equipment - Flint
 1200 S. Averill Ave.
 Flint MI 48503
 Phone: 810-744-0295
 Fax: 855-629-4643
 www.flint.knapheide.com

QUOTATION

Quote ID: KD00002577

Page 3 of 3

The following options may be added:

QTY	PART NUMBER	DESCRIPTION	UNIT PRICE	AMOUNT

Notes:

Please allow approx. 21-22 weeks after the receipt of order.

This Quote is subject to the following terms and conditions:

Credit Card Policy

We do not accept credit cards for payment of any order in excess of \$10,000.00. For other orders, we do accept MasterCard, American Express, Visa and Discover cards for payment.

Pricing Policy

- Price Quotation is good on orders received through the expiration date.
- Pricing quoted applies to chassis make/model originally provided and quantity quoted. Any change may result in price change.
- Orders are subject to all applicable state, local and federal excise taxes. Applicable taxes will be applied on final billing to customer upon completion of order.
- Knapheide Truck Equipment must be in possession of the vehicle for this order within 90 days of quote acceptance or the order can be subject to price adjustments due to cost increases for materials, labor, and shop supplies

Payment Policy

- Payment Terms are due upon receipt of signed quote unless prior credit agreement has been established at the time of order.
- Payment terms for customers with an established credit account will be Net 30 from date of invoice.
- Knapheide has right to assess late charges at 1.5% per month on all invoices that are 60 days or more past due.

Return Policy

- All sales are final. Purchased parts or products are non returnable.

Cancellation Policy

- Payment is due in full upon cancellation of any orders for non-stocked parts or products (provided part/product has been ordered by Knapheide) and upon cancellation of installation orders, once product installation has begun.

Customer agrees and understands this Quote is an offer to sell subject to the terms and conditions above and any additional terms or modifications are hereby objected to, unless mutually agreed upon in writing by Customer and Knapheide. The undersigned represents and warrants that he/she is duly authorized to sign below on behalf of Customer and thereby accepts offer and Knapheide will begin processing the order.

Customer must fill out the information below before the order can be processed...

Signature & Printed Accepted by:	
Date:	
P.O. number:	

PREFERRED

2022 Chassis Cab

F-550 XL

CAB + 1/2 , SEATS 4 TO 5.

Have vehicle questions?



Representative exterior image shown. Actual exterior may vary. See your dealer for details.

Payment

- Base MSRP^{S1} \$50,895
- Total of Options^{S4} \$11,630
- Destination Charges^{S17} \$1,795
- Total MSRP^{S16} \$64,320
- Available Incentives^{S3} -\$0

Estimated Net Price^{S5}

\$64,320

\$1,093 Monthly Payment^{S6} Purchase based on \$6,432 down payment, 60 month term and 5% APR, \$0 trade-in-value

Waterford, MI 48327



Showing the nearest Authorized Dealer for the entered zip code

Model

- 2022 F-550 SuperCab, XL, 4X4, DRW, 168", 6.7L 4 Valve OHV Power Stroke V8 Turbo Diesel Engine, Ten-Speed Automatic with Selectable Drive Modes, 4.88 Limited Slip Axle \$50,895

Paint^{S4}

- Oxford White \$0

Powertrain^{S4}

- 6.7L 4 Valve OHV Power Stroke V8 Turbo Diesel Engine
- 4X4
- Ten-Speed Automatic with Selectable Drive Modes
- 4.88 Limited Slip Axle

Packages^{S4}

- Trailer Tow Package - High Capacity \$580
- Payload Plus Upgrade Package \$1,155

Exterior^{S4}

- 19.5" Argent Painted Steel Wheels \$0
- Transmission Power Take-Off Provision \$0
- Alternator – 332 Amp Dual \$0
- 225/70Rx19.5G BSW A/P Tire \$0
- Manually Telescoping/Folding Trailer Tow with Manual Glass \$0

Interior^{S4}

- Medium Earth Gray \$0
- HD Vinyl, 40/20/40 Split Bench w/Center Armrest and Cupholder Manual Lumbar Seats \$0
- Carpet Delete \$0
- 110V/400W Outlet \$175
- AM/FM Stereo MP3 Player \$0
- SYNC® \$0

- TorqShift® 10-Speed Automatic Transmission with Selectable Drive Modes
- Diesel Engine-Exhaust Braking (Diesel Engine)
- DEF Tank Level Gauge (Diesel Engine)
- Alternator - 240-amp (7.3L)
- Alternator - 240-amp (6.7L)
- Single Battery (750 CCA 78 AH) 7.3L F-450/F-550/F-600 XL & XLT
- Axle - Mono-beam front axle with coil spring suspension - (F-350 4X4, F-450, F-550 and F-600)
- Brakes - 4-wheel power disc brakes with Anti-lock Brake System (ABS); Hydro-boost (DRW)
- AdvanceTrac® With RSC® (Roll Stability Control™) and Trailer Sway Control
- Stationary Elevated Idle Control (SEIC)
- 40 Gallon aft-axle (F-350/F-450/F-550/F-600)
- Shock absorbers - Heavy Duty Gas
- Stabilizer bar - front
- Steering - power
- Steering damper
- Manual locking hubs (4x4 models only)
- Transfer Case - Electronic Shift-On-the-Fly (ESOF) 4-Wheel-Drive System (4x4 models only)
- Live Drive Power Takeoff Provision with Mobile and Stationary PTO Modes Diesel Engine
- Tough and Durable High-Strength Steel Frame
- Wheels - 19.5" x 6" Argent-Painted Steel (DRW)
- 225/70Rx19.5G BSW A/P
- 225/70Rx19.5G BSW A/S (6)

Exterior Features

- Bumper, front - black painted steel with black lower air dam
- Door Handles - black
- Quad Dual-Beam Halogen Headlamps
- LED Roof Marker Clearance Lights

- seat with center armrest, cupholder and storage
- Seats - Front, Manual Lumbar Support, Driver Side
- Seats - Rear, Vinyl 60/40 Fold-Up Bench Seat (SuperCab)
- Seats - Rear, 60/40 Flip-Up/Fold-Down Bench Seat (Crew Cab)
- Medium Earth Gray Interior Environment
- Air Conditioning - Manual Temperature Control
- Audio - AM/FM Stereo, (4 Speakers regular cab, 6 speakers Super Cab and Crew Cab)
- SYNC®
- Ford Pass™ Connect
- Dash-top tray
- Dome Lamp - door-activated instrument panel switch operated with delay
- Floor Covering - black vinyl
- Grab handles - driver and front passenger and roof ride handles; front passenger (also over rear doors with Crew Cab)
- Headliner - color coordinated cloth
- Instrumentation with tachometer and Message Center including odometer, trip odometer, distance-to-empty, average fuel economy, engine hour meter and warning messages
- Instrument Cluster - 2.3" Productivity Screen
- Map lights - dual (front and rear with Crew Cab)
- Powerpoint - Two Powerpoint in instrumentation center
- Steering Wheel Audio Controls
- Steering Wheel - Black Molded Polyurethane
- Visors - vinyl, driver w/pocket, passenger w/uncovered mirror
- Manual Tilt/telescoping steering wheel
- Six Factory-Installed Auxiliary Upfitter Switches
- Windshield wipers - intermittent control

Safety

- Airbags - front seat front with passenger-side deactivation switch (Regular Cab and SuperCab only)
- Airbags - Front seat and passenger Frontal

- with Manual Glass
- Glass - rear, solar tinted
- Window - rear, fixed, solar tinted

- buckled
- Child tethers (Regular Cab, front passenger and all rear seating positions)
- Seat Belts - color coordinated with height adjustment (front outboard seating positions only)
- SOS Post Crash Alert System
- Autolamp (Auto On/Off Headlamps) with Rainlamp Wiper Activated Headlamps

Packages

- SecuriLock® Passive Anti-Theft System (PATS)

Your Configuration: 2022 F-550 SuperCab, XL, 4X4, DRW, 168", 6.7L 4 Valve OHV Power Stroke V8 Turbo Diesel Engine, Ten-Speed Automatic with Selectable Drive Modes, 4.88 Limited Slip Axle

Pricing shown for Zip code 48383 as of June 7, 2022 ^{S2}

Note. Information is provided on an "as is" basis and could include technical, typographical or other errors. Ford makes no warranties, representations, or guarantees of any kind, express or implied, including but not limited to, accuracy, currency, or completeness, the operation of the Site, the information, materials, content, availability, and products. Ford reserves the right to change product specifications, pricing and equipment at any time without incurring obligations. Your Ford dealer is the best source of the most up-to-date information on Ford vehicles.

Disclosures through S18 apply to Search Dealer Inventory, Request A Quote, Get An Internet Price, Get A Quote, Let Us Find It For You, Build & Price and Incentives & Offers.

S1.

Manufacturer's Suggested Retail Price (also referred to as "MSRP", "Base MSRP", "Base Price" or the "Starting At" price), excludes destination/delivery charge, taxes, title, license, and registration and/or electronic filing fees, dealer fees, and total of options.

For authenticated AXZ Plan customers, the price displayed may represent Plan pricing. Not all AXZ Plan customers will qualify for the Plan pricing shown and not all offers or incentives are available to AXZ Plan customers.

S2.

Images shown are for information purposes only, and may not necessarily represent the configurable options selected or available on the vehicle. We cannot be responsible for typographical or other errors, including data transmission, display, or software errors, that may appear on the site.

S3.

Offers shown may not be available to all customers. Incentives lists are examples of offers available at the time of posting and are subject to change and expiration. Not all incentives can be redeemed together. To take advantage of rebates, incentives and/or financing offers you must take new retail delivery from dealer stock by the expiration date noted. Not all buyers will qualify for Ford Credit financing or other offers. Restrictions apply. See your local dealer for complete details.

S4.

The Option Package price and monthly payment displayed is for illustration purposes, only. Prices and monthly payments may vary based on features included in package, financing terms and availability. Some Options are not available separately. Not all Options or Option Packages are available on all vehicles. See your local dealer for details.

S5. Estimated Net Price is the Total Manufacturer's Suggested Retail Price ("Total MSRP") minus any available offers and/or incentives. Incentives may vary. Excludes taxes, title, and registration fees. For authenticated AXZ Plan customers, the price displayed may represent Plan pricing. Not all AXZ Plan customers will qualify for the Plan pricing shown and not all offers or incentives are available to AXZ Plan customers.

estimates only, and are based on amount of down payment, APR and term. Lease payment calculations are estimates only, and are based on an annual mileage calculation determined by your dealer. A charge is assessed for any mileage driven that exceeds this limit. Lessee is responsible for \$395 lease Disposition Fee in select states. Not all buyers will qualify for financing or a lease. Contact your local Ford or Lincoln Dealer for details.

S7.

While dealer inventory is generally updated on a daily basis, there are no guarantees that the inventory shown will be available at the dealership. Mid-model-year manufacturing changes, as well as dealer-added accessories on the actual vehicle may differ from the options and features listed. Vehicles that are identified as 'Exact Matches' may have a different price or different features not represented on the site. We make every effort to provide you with the most accurate, up-to-date information, however, only your local Ford dealer can provide you with information regarding actual vehicle availability.

S8.

Dealer Accessories are defined as items that do not appear on the factory window sticker that are installed by a Ford or Lincoln Dealers. Actual Prices for all accessories may vary and depend upon your dealer. Prices DO NOT include installation or painting, which may be required for particular items. Please check with your authorized dealer for complete pricing accuracy for all accessories and parts.

Genuine Ford Accessories will be warranted for whichever provides you the greatest benefit: 12 months or 12,000 miles (whichever occurs first) or the remainder of your Bumper-to-Bumper 3-year/36,000-mile New Vehicles Warranty. Contact your local Ford, Lincoln or Mercury dealer for details and a copy of the limited warranty.

Ford Licensed Accessories (FLA) are warranted by the accessories manufacturer's warranty. Contact your Ford, Lincoln or Mercury Dealer for details regarding the manufacturer's limited warranty and/or a copy of the FLA product limited warranty offered by the accessory manufacturer.

Most Ford Racing Performance Parts are sold with no warranty. Ford Racing Performance Parts are sold "As Is", "With All Faults", "As They Stand" and without any express warranty whatsoever, unless otherwise expressly designated herein. To determine which parts come with a warranty from the original manufacturer, or from Ford Racing, please contact the Ford Racing Techline at (800) FORD788.

S9.

The "Trade-In Value" of your vehicle is an estimate, only, and many factors that cannot be assessed without a physical inspection of the vehicle may affect actual value. For purposes of this website, we use the services of a third-party vendor to provide Trade-In Value calculations. While we believe this information is reliable, we are not responsible for and do not guarantee the accuracy or reliability of the information. Please see your local Ford dealer for information regarding actual trade-in availability and value.

S10.

AXZ Plan pricing, including AXZ Plan option pricing, is exclusively for eligible Ford Motor Company employees, friends and family-members of eligible employees, and Ford Motor Company eligible partners. Restrictions apply. See your Ford or Lincoln dealer for complete details and qualifications. Ford Motor Company reserves the right to modify the terms of AXZ Plan pricing or availability at any time. Some dealers may also chose not to participate in plan pricing Contact your local dealer to determine final pricing.

S11.

EPA estimated city/highway mpg based on base engine/transmission configuration. Actual mileage will vary.

S12.

Towing - Properly equipped.

S13.

For Dealer Ordered vehicles, the vehicle has already been ordered by the dealer and is in the process of being manufactured by the factory. If you are interested in the vehicle marked "Dealer Ordered", contact the dealership for a delivery estimate.

S14. The "estimated selling price" is for estimation purposes only and the figures presented do not represent an offer that can be accepted by you. See your local dealer for vehicle availability and actual price. The Estimated Selling Price shown is the Base MSRP plus destination charges and total of options, but does not include service contracts, insurance or any outstanding prior credit balance. Does not include tax, title or registration fees. It also includes the acquisition fee. For Commercial Lease product, upfit amounts are included.

The "estimated capitalized cost" is for estimation purposes only and the figures presented do not represent an offer that can be accepted by you. See your local dealer for vehicle availability, actual price, and financing options. Estimated Capitalized Cost shown is the Base MSRP plus destination charges and total of options, but does not include service contracts, insurance or any outstanding prior credit balance. Does not include tax, title or registration fees. It also includes the acquisition fee. For Commercial Lease product, upfit amounts are included.

S15. The "amount financed" is for estimation purposes only and the figures presented do not represent an offer that can be

Capitalized Cost is the amount used to determine the Estimated Monthly Payment. It is equal to the Estimated Capitalized Cost less Down Payment, Available Incentives, and Net Trade-in Amount.

S16.

Total MSRP is Base MSRP plus options, destination and delivery charges. Excludes taxes, title, and registration fees.

S17.

Destination Charges are associated with getting the vehicle from the manufacturer to the dealership. Prices listed are MSRP and are based on information updated on this website from time to time.

S18. Acquisition Fee is a charge paid by the lessee to Ford Credit to help cover the cost of acquiring and servicing the account. Note2.

For Manufacturer Specific Disclosures See Below

1.

Starting MSRP excludes destination/delivery charge, taxes, title and registration. Optional equipment not included. Starting A, Z and X Plan price is for qualified, eligible customers and excludes document fee, destination/delivery charge, taxes, title and registration. Not all vehicles qualify for A, Z or X Plan. All Mustang Shelby GT350 and Shelby GT350R prices exclude gas guzzler tax.

2.

EPA-estimated city/hwy mpg. See fuelconomy.gov for fuel economy of other engine/transmission combinations. Actual mileage will vary. MPGe is the EPA equivalent measure of gasoline fuel efficiency for electric mode operation.

DISCLOSURES ()

2022 Chassis Cab

F-550 XL

REG. CAB, SEATS 3.

Have vehicle questions?



Representative exterior image shown. Actual exterior may vary. See your dealer for details.

Payment

- Base MSRP^{S1} \$45,630
- Total of Options^{S4} \$12,195
- Destination Charges^{S17} \$1,795
- Total MSRP^{S16} \$59,620
- Available Incentives^{S3} -\$0

Estimated Net Price^{S5}

\$59,620

\$1,013 Monthly Payment^{S6} Purchase based on \$5,962 down payment, 60 month term and 5% APR, \$0 trade-in-value

Waterford, MI 48327

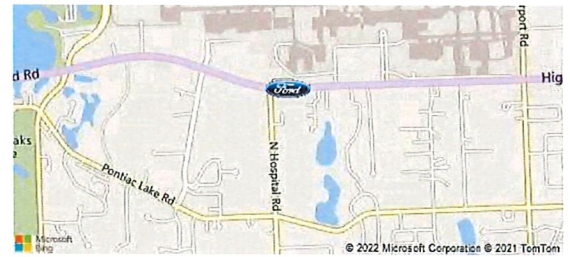

Showing the nearest Authorized Dealer for the entered zip code

Model

- 2022 F-550 Regular Cab, XL, 4X2, DRW, 205", 6.7L 4 Valve OHV Power Stroke V8 Turbo Diesel Engine, Ten-Speed Automatic with Selectable Drive Modes, 4.88 Limited Slip Axle \$45,630

Paint^{S4}

- Oxford White \$0

Powertrain^{S4}

- 6.7L 4 Valve OHV Power Stroke V8 Turbo Diesel Engine
- 4X2
- Ten-Speed Automatic with Selectable Drive Modes
- 4.88 Limited Slip Axle

Packages^{S4}

- Trailer Tow Package - High Capacity \$580
- Payload Plus Upgrade Package \$1,155

Exterior^{S4}

- 19.5" Argent Painted Steel Wheels \$0
- Transmission Power Take-Off Provision \$0
- Exterior Backup Alarm \$150
- Alternator – 332 Amp Dual \$0
- Rear View Camera and Prep Kit \$415
- 225/70Rx19.5G BSW A/P Tire \$0
- Manually Telescoping/Folding Trailer Tow with Manual Glass \$0

Interior^{S4}

- Medium Earth Gray \$0
- HD Vinyl, 40/20/40 Split Bench w/Center Armrest and Cupholder Manual Lumbar Seats \$0
- Carpet Delete \$0
- 110V/400W Outlet \$175

Standard Features

Power and Handling

- Engine - 7.3L 2V DECVT V8 Gas
- TorqShift® 10-Speed Automatic Transmission with Selectable Drive Modes
- Diesel Engine-Exhaust Braking (Diesel Engine)
- DEF Tank Level Gauge (Diesel Engine)
- Alternator - 240-amp (7.3L)
- Alternator - 240-amp (6.7L)
- Single Battery (750 CCA 78 AH) 7.3L F-450/F-550/F-600 XL & XLT
- Axle - Mono-beam front axle with coil spring suspension - (F-350 4X4, F-450, F-550 and F-600)
- Brakes - 4-wheel power disc brakes with Anti-lock Brake System (ABS); Hydro-boost (DRW)
- AdvanceTrac® With RSC® (Roll Stability Control™) and Trailer Sway Control
- Stationary Elevated Idle Control (SEIC)
- 40 Gallon aft-axle (F-350/F-450/F-550/F-600)
- Shock absorbers - Heavy Duty Gas
- Stabilizer bar - front
- Steering - power
- Steering damper
- Manual locking hubs (4x4 models only)
- Transfer Case - Electronic Shift-On-the-Fly (ESOF) 4-Wheel-Drive System (4x4 models only)
- Live Drive Power Takeoff Provision with Mobile and Stationary PTO Modes Diesel Engine
- Tough and Durable High-Strength Steel Frame
- Wheels - 19.5" x 6" Argent-Painted Steel (DRW)
- 225/70Rx19.5G BSW A/P
- 225/70Rx19.5G BSW A/S (6)

Exterior Features

- Bumper, front - black painted steel with black lower air dam

Interior Features

- Seats - Front, Vinyl 40/20/40 split-bench seat with center armrest, cupholder and storage
- Seats - Front, Manual Lumbar Support, Driver Side
- Seats - Rear, Vinyl 60/40 Fold-Up Bench Seat (SuperCab)
- Seats - Rear, 60/40 Flip-Up/Fold-Down Bench Seat (Crew Cab)
- Medium Earth Gray Interior Environment
- Air Conditioning - Manual Temperature Control
- Audio - AM/FM Stereo, (4 Speakers regular cab, 6 speakers Super Cab and Crew Cab)
- SYNC®
- Ford Pass™ Connect
- Dash-top tray
- Dome Lamp - door-activated instrument panel switch operated with delay
- Floor Covering - black vinyl
- Grab handles - driver and front passenger and roof ride handles; front passenger (also over rear doors with Crew Cab)
- Headliner - color coordinated cloth
- Instrumentation with tachometer and Message Center including odometer, trip odometer, distance-to-empty, average fuel economy, engine hour meter and warning messages
- Instrument Cluster - 2.3" Productivity Screen
- Map lights - dual (front and rear with Crew Cab)
- Powerpoint - Two Powerpoint in instrumentation center
- Steering Wheel Audio Controls
- Steering Wheel - Black Molded Polyurethane
- Visors - vinyl, driver w/pocket, passenger w/uncovered mirror
- Manual Tilt/telescoping steering wheel
- Six Factory-Installed Auxiliary Upfitter Switches
- Windshield wipers - intermittent control

Safety

- Airbags - front seat front with passenger-side deactivation switch (Regular Cab and

- Splash Guards/Mud Flaps - Front
- Grille - Black bar-style
- Mirrors - Manual Telescoping Trailer Tow with Manual Glass
- Glass - rear, solar tinted
- Window - rear, fixed, solar tinted

- side-curtain airbags
- Belt-Minder®, chime and flashing warning light on instrument cluster if belts not buckled
- Child tethers (Regular Cab, front passenger and all rear seating positions)
- Seat Belts - color coordinated with height adjustment (front outboard seating positions only)
- SOS Post Crash Alert System
- Autolamp (Auto On/Off Headlamps) with Rainlamp Wiper Activated Headlamps

Packages

- SecuriLock® Passive Anti-Theft System (PATS)

Your Configuration: 2022 F-550 Regular Cab, XL, 4X2, DRW, 205", 6.7L 4 Valve OHV Power Stroke V8 Turbo Diesel Engine, Ten-Speed Automatic with Selectable Drive Modes, 4.88 Limited Slip Axle
Pricing shown for Zip code 48383 as of June 7, 2022 ^{S2}

Note. Information is provided on an "as is" basis and could include technical, typographical or other errors. Ford makes no warranties, representations, or guarantees of any kind, express or implied, including but not limited to, accuracy, currency, or completeness, the operation of the Site, the information, materials, content, availability, and products. Ford reserves the right to change product specifications, pricing and equipment at any time without incurring obligations. Your Ford dealer is the best source of the most up-to-date information on Ford vehicles.

Disclosures through S18 apply to Search Dealer Inventory, Request A Quote, Get An Internet Price, Get A Quote, Let Us Find It For You, Build & Price and Incentives & Offers.

S1.

Manufacturer's Suggested Retail Price (also referred to as "MSRP", "Base MSRP", "Base Price" or the "Starting At" price), excludes destination/delivery charge, taxes, title, license, and registration and/or electronic filing fees, dealer fees, and total of options.

For authenticated AXZ Plan customers, the price displayed may represent Plan pricing. Not all AXZ Plan customers will qualify for the Plan pricing shown and not all offers or incentives are available to AXZ Plan customers.

S2.

Images shown are for information purposes only, and may not necessarily represent the configurable options selected or available on the vehicle. We cannot be responsible for typographical or other errors, including data transmission, display, or software errors, that may appear on the site.

S3.

Offers shown may not be available to all customers. Incentives lists are examples of offers available at the time of posting and are subject to change and expiration. Not all incentives can be redeemed together. To take advantage of rebates, incentives and/or financing offers you must take new retail delivery from dealer stock by the expiration date noted. Not all buyers will qualify for Ford Credit financing or other offers. Restrictions apply. See your local dealer for complete details.

S4.

The Option Package price and monthly payment displayed is for illustration purposes, only. Prices and monthly payments may vary based on features included in package, financing terms and availability. Some Options are not available separately. Not all Options or Option Packages are available on all vehicles. See your local dealer for details.

S5. Estimated Net Price is the Total Manufacturer's Suggested Retail Price ("Total MSRP") minus any available offers and/or

the dealer-installed accessories. For authenticated AXZ Plan customers, the price displayed may represent Plan pricing. Not all AXZ Plan customers will qualify for the Plan pricing shown. Actual monthly payment is based on a variety of factors, including differing financing or leasing terms, accessory prices and installation costs. Financing payment calculations are estimates only, and are based on amount of down payment, APR and term. Lease payment calculations are estimates only, and are based on an annual mileage calculation determined by your dealer. A charge is assessed for any mileage driven that exceeds this limit. Lessee is responsible for \$395 lease Disposition Fee in select states. Not all buyers will qualify for financing or a lease. Contact your local Ford or Lincoln Dealer for details.

S7.

While dealer inventory is generally updated on a daily basis, there are no guarantees that the inventory shown will be available at the dealership. Mid-model-year manufacturing changes, as well as dealer-added accessories on the actual vehicle may differ from the options and features listed. Vehicles that are identified as 'Exact Matches' may have a different price or different features not represented on the site. We make every effort to provide you with the most accurate, up-to-date information, however, only your local Ford dealer can provide you with information regarding actual vehicle availability.

S8.

Dealer Accessories are defined as items that do not appear on the factory window sticker that are installed by a Ford or Lincoln Dealers. Actual Prices for all accessories may vary and depend upon your dealer. Prices DO NOT include installation or painting, which may be required for particular items. Please check with your authorized dealer for complete pricing accuracy for all accessories and parts.

Genuine Ford Accessories will be warranted for whichever provides you the greatest benefit: 12 months or 12,000 miles (whichever occurs first) or the remainder of your Bumper-to-Bumper 3-year/36,000-mile New Vehicles Warranty. Contact your local Ford, Lincoln or Mercury dealer for details and a copy of the limited warranty.

Ford Licensed Accessories (FLA) are warranted by the accessories manufacturer's warranty. Contact your Ford, Lincoln or Mercury Dealer for details regarding the manufacturer's limited warranty and/or a copy of the FLA product limited warranty offered by the accessory manufacturer.

Most Ford Racing Performance Parts are sold with no warranty. Ford Racing Performance Parts are sold "As Is", "With All Faults", "As They Stand" and without any express warranty whatsoever, unless otherwise expressly designated herein. To determine which parts come with a warranty from the original manufacturer, or from Ford Racing, please contact the Ford Racing Techline at (800) FORD788.

S9.

The "Trade-In Value" of your vehicle is an estimate, only, and many factors that cannot be assessed without a physical inspection of the vehicle may affect actual value. For purposes of this website, we use the services of a third-party vendor to provide Trade-In Value calculations. While we believe this information is reliable, we are not responsible for and do not guarantee the accuracy or reliability of the information. Please see your local Ford dealer for information regarding actual trade-in availability and value.

S10.

AXZ Plan pricing, including AXZ Plan option pricing, is exclusively for eligible Ford Motor Company employees, friends and family-members of eligible employees, and Ford Motor Company eligible partners. Restrictions apply. See your Ford or Lincoln dealer for complete details and qualifications. Ford Motor Company reserves the right to modify the terms of AXZ Plan pricing or availability at any time. Some dealers may also chose not to participate in plan pricing Contact your local dealer to determine final pricing.

S11.

EPA estimated city/highway mpg based on base engine/transmission configuration. Actual mileage will vary.

S12.

Towing - Properly equipped.

S13.

For Dealer Ordered vehicles, the vehicle has already been ordered by the dealer and is in the process of being manufactured by the factory. If you are interested in the vehicle marked "Dealer Ordered", contact the dealership for a delivery estimate.

S14. The "estimated selling price" is for estimation purposes only and the figures presented do not represent an offer that can be accepted by you. See your local dealer for vehicle availability and actual price. The Estimated Selling Price shown is the Base MSRP plus destination charges and total of options, but does not include service contracts, insurance or any outstanding prior credit balance. Does not include tax, title or registration fees. It also includes the acquisition fee. For Commercial Lease product, upfit amounts are included.

The "estimated capitalized cost" is for estimation purposes only and the figures presented do not represent an offer that can be accepted by you. See your local dealer for vehicle availability, actual price, and financing options. Estimated Capitalized Cost shown is the Base MSRP plus destination charges and total of options, but does not include service contracts, insurance or any outstanding prior credit balance. Does not include tax, title or registration fees. It also includes the acquisition fee. For

vehicle less Down Payment, Available Incentives and Net Trade-in Amount.

The "adjusted capitalized cost" is for estimation purposes only and the figures presented do not represent an offer that can be accepted by you. See your local dealer for vehicle availability, actual price, and financing options. Estimated Adjusted Capitalized Cost is the amount used to determine the Estimated Monthly Payment. It is equal to the Estimated Capitalized Cost less Down Payment, Available Incentives, and Net Trade-in Amount.

S16.

Total MSRP is Base MSRP plus options, destination and delivery charges. Excludes taxes, title, and registration fees.

S17.

Destination Charges are associated with getting the vehicle from the manufacturer to the dealership. Prices listed are MSRP and are based on information updated on this website from time to time.

S18. Acquisition Fee is a charge paid by the lessee to Ford Credit to help cover the cost of acquiring and servicing the account. Note2.

For Manufacturer Specific Disclosures See Below

1.

Starting MSRP excludes destination/delivery charge, taxes, title and registration. Optional equipment not included. Starting A, Z and X Plan price is for qualified, eligible customers and excludes document fee, destination/delivery charge, taxes, title and registration. Not all vehicles qualify for A, Z or X Plan. All Mustang Shelby GT350 and Shelby GT350R prices exclude gas guzzler tax.

2.

EPA-estimated city/hwy mpg. See fuelconomy.gov for fuel economy of other engine/transmission combinations. Actual mileage will vary. MPGe is the EPA equivalent measure of gasoline fuel efficiency for electric mode operation.

DISCLOSURES ()

MAINTENANCE

2022 Transit Connect

XL Cargo Van

Have vehicle questions?



Payment

- Base MSRP^{S1} \$29,365
- Total of Options^{S4} \$1,710
- Destination Charges^{S17} \$1,395
- Acquisition Fee^{S18} \$645
- Total MSRP^{S16} \$33,115
- Available Incentives^{S3} -\$250

RCL Customer Cash

Program #50596: For Red Carpet Lease incentives \$250.00, take new retail delivery from dealer stock by 07/05/2022. See dealer for complete details.

Amount: \$250, Offer Valid: May 3, 2022-Jul 5, 2022

Estimated Net Price^{S5}

\$32,865

\$508 Monthly Payment^{S6} Lease based on \$3,247 down payment, 39 month term and 10,500 mileage, \$0 trade-in-value

Waterford, MI 48327

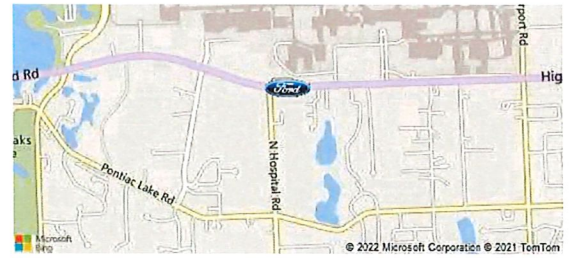

Showing the nearest Authorized Dealer for the entered zip code

Model

- 2022 Ford Transit Connect XL Van SWB 100A - Dual Sliding Doors with Rear Symmetrical Doors, 2.0L GDI I-4 Gas Engine, Eight-Speed SelectShift® Automatic \$29,365

Paint^{S4}

- Frozen White \$0

Powertrain^{S4}

- 2.0L GDI I-4 Gas Engine
- Eight-Speed SelectShift® Automatic

Exterior^{S4}

- 16" Sparkle Silver-Painted Steel Wheels with Full Wheel Covers \$0
- 2nd Row Fixed Glass – Passenger Side Only \$95
- MyKey® \$230
- Rear Door Fixed Glass \$295
- Rear Window Defroster \$150
- Power Adjust, PowerFold, Heated Exterior Mirrors \$0
- BLIS® (Blind Spot Information System) with Cross-Traffic Alert \$575
- Reverse Sensing System \$295
- Heavy Duty Battery \$0

Interior^{S4}

- Ebony \$0
- Ebony Vinyl Seats with Dark Palazzo Gray Inserts – Crosshatch/Salerno vinyl \$0
- Rear Cargo Area Light – LED \$70
- Vinyl Floor Cover – Front Row \$0
- Cruise Control \$0
- AM/FM Radio with Bluetooth and 4.2" LCD Multi-Function Display Screen, plus 1 USB Port \$0

Standard Features

Home Feature

- Configurable Daytime Running Lamps (DRLs)
- Black Door Handles
- Front Bumper - Black Molded-in-color
- Integrated Spotter Mirrors
- Manual Adjust Exterior Mirrors with Manual Fold – Black
- Rain-Sensing Front Wipers
- 3-Bar Grille with Black Surround
- Rear Bumper - Black Molded-in-Color
- Rear Bumper End Caps - Black Molded-in-Color
- Windshield Wipers - Front Variable Intermittent Wipers
- Easy Fuel[®] Capless Fuel-Filler (with fill door cover and misfuel inhibitor)
- HID (High Intensity Discharge) Headlamps
- Bodyside Moldings - Black, Molded-in-Color
- Full-Size Spare Tire
- Dual Sliding Side Doors
- Power Front Row Windows with One-Touch Down on Driver's Side

- 12-volt Single Powerpoint In Rear Cargo Area
- 4-Spoke Steering Wheel
- Driver sunvisor and passenger sunvisor
- Door Pockets
- Glove Box
- Front Center Open Console with 2 Cupholders
- Front Dome Light
- Front-Row Full-Width Overhead Storage Shelf with Grab Handles
- Rear Cargo Area Light - Halogen
- Rear Cargo Vinyl Floor Cover
- Remote Keyless-Entry with 2 Key Fobs
- Speedometer (MPH/KPH), Tachometer and Trip Computer
- Tilt/Telescoping Steering Wheel
- Vinyl Floor Covering - Front Row (and Second Row on Passenger Wagon)
- FordPass Connect[™]
- 4.2" LCD Multi-function display with steering wheel controls
- Speakers - 4 Front
- AM/FM Radio with Bluetooth and 4.2" LCD Multi-Function Display Screen, plus 1 USB Port
- Seating - Vinyl
- Seating, Two-Passenger
- 6-Way Manual Driver Seat and 4-Way Manual Passenger Seat (with fold-flat back)

Packages**Power and Handling**

- Electric Power-Assisted Steering (EPAS)
- Pre-Collision Assist with Automatic Emergency Braking
- Front-Wheel Drive (FWD)
- Hill Start Assist
- Power 4-Wheel Disc Anti-Lock Brake System (ABS)
- Independent Macpherson Strut Front and Twist-Beam Rear Suspension
- AdvanceTrac[®] with RSC[®]
- Side-Wind Stabilization
- 15.8-Gallon Fuel Tank Capacity
- Standard Alternator - 150 amp
- Auto Start-Stop Technology
- EcoMode and EcoCoach (2.0L Engine)
- 2.0L GDI I-4 Engine
- Heavy Duty Battery - 80-amp/800-CCA
- 8-speed SelectShift[®] Automatic

- Driver and Passenger Front Seat Side Airbags
- Tire Pressure Monitoring System (TPMS)
- Curve Control
- Torque Vectoring Control
- Emergency Brake Assist
- SecuriLock® Passive Anti-Theft System (PATS)

Your Configuration: 2022 Ford Transit Connect XL Van SWB 100A - Dual Sliding Doors with Rear Symmetrical Doors, 2.0L GDI I-4 Gas Engine, Eight-Speed SelectShift® Automatic

Pricing shown for Zip code 48383 as of June 7, 2022 ^{S2}

Note. Information is provided on an "as is" basis and could include technical, typographical or other errors. Ford makes no warranties, representations, or guarantees of any kind, express or implied, including but not limited to, accuracy, currency, or completeness, the operation of the Site, the information, materials, content, availability, and products. Ford reserves the right to change product specifications, pricing and equipment at any time without incurring obligations. Your Ford dealer is the best source of the most up-to-date information on Ford vehicles.

Disclosures through S18 apply to Search Dealer Inventory, Request A Quote, Get An Internet Price, Get A Quote, Let Us Find It For You, Build & Price and Incentives & Offers.

S1.

Manufacturer's Suggested Retail Price (also referred to as "MSRP", "Base MSRP", "Base Price" or the "Starting At" price), excludes destination/delivery charge, taxes, title, license, and registration and/or electronic filing fees, dealer fees, and total of options.

For authenticated AXZ Plan customers, the price displayed may represent Plan pricing. Not all AXZ Plan customers will qualify for the Plan pricing shown and not all offers or incentives are available to AXZ Plan customers.

S2.

Images shown are for information purposes only, and may not necessarily represent the configurable options selected or available on the vehicle. We cannot be responsible for typographical or other errors, including data transmission, display, or software errors, that may appear on the site.

S3.

Offers shown may not be available to all customers. Incentives lists are examples of offers available at the time of posting and are subject to change and expiration. Not all incentives can be redeemed together. To take advantage of rebates, incentives and/or financing offers you must take new retail delivery from dealer stock by the expiration date noted. Not all buyers will qualify for Ford Credit financing or other offers. Restrictions apply. See your local dealer for complete details.

S4.

The Option Package price and monthly payment displayed is for illustration purposes, only. Prices and monthly payments may vary based on features included in package, financing terms and availability. Some Options are not available separately. Not all Options or Option Packages are available on all vehicles. See your local dealer for details.

S5. Estimated Net Price is the Total Manufacturer's Suggested Retail Price ("Total MSRP") minus any available offers and/or incentives. Incentives may vary. Excludes taxes, title, and registration fees. For authenticated AXZ Plan customers, the price displayed may represent Plan pricing. Not all AXZ Plan customers will qualify for the Plan pricing shown and not all offers or incentives are available to AXZ Plan customers.

S6.

The payment estimator will calculate a monthly payment based on the MSRP of the vehicle you have configured, including the dealer-installed accessories. For authenticated AXZ Plan customers, the price displayed may represent Plan pricing. Not all AXZ Plan customers will qualify for the Plan pricing shown. Actual monthly payment is based on a variety of factors, including differing financing or leasing terms, accessory prices and installation costs. Financing payment calculations are estimates only, and are based on amount of down payment, APR and term. Lease payment calculations are estimates only,

While dealer inventory is generally updated on a daily basis, there are no guarantees that the inventory shown will be available at the dealership. Mid-model-year manufacturing changes, as well as dealer-added accessories on the actual vehicle may differ from the options and features listed. Vehicles that are identified as 'Exact Matches' may have a different price or different features not represented on the site. We make every effort to provide you with the most accurate, up-to-date information, however, only your local Ford dealer can provide you with information regarding actual vehicle availability.

S8.

Dealer Accessories are defined as items that do not appear on the factory window sticker that are installed by a Ford or Lincoln Dealers. Actual Prices for all accessories may vary and depend upon your dealer. Prices DO NOT include installation or painting, which may be required for particular items. Please check with your authorized dealer for complete pricing accuracy for all accessories and parts.

Genuine Ford Accessories will be warranted for whichever provides you the greatest benefit: 12 months or 12,000 miles (whichever occurs first) or the remainder of your Bumper-to-Bumper 3-year/36,000-mile New Vehicles Warranty. Contact your local Ford, Lincoln or Mercury dealer for details and a copy of the limited warranty.

Ford Licensed Accessories (FLA) are warranted by the accessories manufacturer's warranty. Contact your Ford, Lincoln or Mercury Dealer for details regarding the manufacturer's limited warranty and/or a copy of the FLA product limited warranty offered by the accessory manufacturer.

Most Ford Racing Performance Parts are sold with no warranty. Ford Racing Performance Parts are sold "As Is", "With All Faults", "As They Stand" and without any express warranty whatsoever, unless otherwise expressly designated herein. To determine which parts come with a warranty from the original manufacturer, or from Ford Racing, please contact the Ford Racing Techline at (800) FORD788.

S9.

The "Trade-In Value" of your vehicle is an estimate, only, and many factors that cannot be assessed without a physical inspection of the vehicle may affect actual value. For purposes of this website, we use the services of a third-party vendor to provide Trade-In Value calculations. While we believe this information is reliable, we are not responsible for and do not guarantee the accuracy or reliability of the information. Please see your local Ford dealer for information regarding actual trade-in availability and value.

S10.

AXZ Plan pricing, including AXZ Plan option pricing, is exclusively for eligible Ford Motor Company employees, friends and family-members of eligible employees, and Ford Motor Company eligible partners. Restrictions apply. See your Ford or Lincoln dealer for complete details and qualifications. Ford Motor Company reserves the right to modify the terms of AXZ Plan pricing or availability at any time. Some dealers may also chose not to participate in plan pricing Contact your local dealer to determine final pricing.

S11.

EPA estimated city/highway mpg based on base engine/transmission configuration. Actual mileage will vary.

S12.

Towing - Properly equipped.

S13.

For Dealer Ordered vehicles, the vehicle has already been ordered by the dealer and is in the process of being manufactured by the factory. If you are interested in the vehicle marked "Dealer Ordered", contact the dealership for a delivery estimate.

S14. The "estimated selling price" is for estimation purposes only and the figures presented do not represent an offer that can be accepted by you. See your local dealer for vehicle availability and actual price. The Estimated Selling Price shown is the Base MSRP plus destination charges and total of options, but does not include service contracts, insurance or any outstanding prior credit balance. Does not include tax, title or registration fees. It also includes the acquisition fee. For Commercial Lease product, upfit amounts are included.

The "estimated capitalized cost" is for estimation purposes only and the figures presented do not represent an offer that can be accepted by you. See your local dealer for vehicle availability, actual price, and financing options. Estimated Capitalized Cost shown is the Base MSRP plus destination charges and total of options, but does not include service contracts, insurance or any outstanding prior credit balance. Does not include tax, title or registration fees. It also includes the acquisition fee. For Commercial Lease product, upfit amounts are included.

S15. The "amount financed" is for estimation purposes only and the figures presented do not represent an offer that can be accepted by you. See your local dealer for vehicle availability, actual price, and financing options. Estimated Amount Financed is the amount used to determine the Estimated Monthly Payment. It is equal to the Estimated Selling Price of the vehicle less Down Payment, Available Incentives and Net Trade-in Amount.

The "adjusted capitalized cost" is for estimation purposes only and the figures presented do not represent an offer that can be accepted by you. See your local dealer for vehicle availability, actual price, and financing options. Estimated Adjusted Capitalized Cost is the amount used to determine the Estimated Monthly Payment. It is equal to the Estimated Capitalized

317.

Destination Charges are associated with getting the vehicle from the manufacturer to the dealership. Prices listed are MSRP and are based on information updated on this website from time to time.

S18. Acquisition Fee is a charge paid by the lessee to Ford Credit to help cover the cost of acquiring and servicing the account. Note2.

For Manufacturer Specific Disclosures See Below

1.

Starting MSRP excludes destination/delivery charge, taxes, title and registration. Optional equipment not included. Starting A, Z and X Plan price is for qualified, eligible customers and excludes document fee, destination/delivery charge, taxes, title and registration. Not all vehicles qualify for A, Z or X Plan. All Mustang Shelby GT350 and Shelby GT350R prices exclude gas guzzler tax.

2.

EPA-estimated city/hwy mpg. See fuelconomy.gov for fuel economy of other engine/transmission combinations. Actual mileage will vary. MPGe is the EPA equivalent measure of gasoline fuel efficiency for electric mode operation.

DISCLOSURES ()