

**WHITE LAKE TOWNSHIP  
INTER-OFFICE MEMORANDUM**

***COMMUNITY DEVELOPMENT DEPARTMENT***

**DATE:** June 9, 2021

**TO:** Rik Kowall, Supervisor  
Township Board Members

**FROM:** Sean O'Neil, AICP  
Planning Director

**SUBJECT: Oakland Harvesters (Preliminary Site Plan)**

Located on the north side of White Lake Road, west of Old White Lake Road and east of Orr Road. Consisting of approximately 2 acres. Currently zoned Light Manufacturing (LM). Identified as parcel 12-01-127-001.

The above project will be considered at the July 15, 2021 Planning Commission meeting. Minutes from the July 15, 2021 meeting will be sent to you under separate cover as soon as they are available.

Please find enclosed the following related documents:

- Memo from Sean O'Neil, Planner Director
- Letter from Ty Nuottka, applicant for Oakland Harvesters.
- Review letter prepared by the Township Engineering Consultant, Mr. Michael Leuffgen, dated 05/26/2021.
- Review letters prepared by the Township Planning Consultant, Ms Kathleen Jackson, dated 06/24/2021.
- Review letter prepared by the White Lake Township Fire Chief, dated 06/01/2021.
- Memo prepared by the White Lake Township Assessor, dated 05/27/2021
- Review letter prepared by the Township Assessor, dated 05/19/2020.

Please place this matter on the next available Township Board agenda. Contact me should you require additional information.

## **WHITE LAKE TOWNSHIP**

### ***COMMUNITY DEVELOPMENT DEPARTMENT***

**DATE:** July 8, 2021

**TO:** Planning Commission

**FROM:** Sean O'Neil, Planning Director

**SUBJECT:** Oakland Harvesters – Preliminary Site Plan and Special Land Use

Please find attached a letter from Ty Nuottila of the Oakland Harvesters. He wishes to address the comments and concerns found within the review letters prior to making plan revisions, and attempts to do so in his letter. He asks to have the Preliminary Site Plan and Special Land Use requests considered at the July 15<sup>th</sup> meeting.

I look forward to discussing this further with you all on July 15<sup>th</sup> when we meet. Please contact me if you have any questions or require additional information.

Thank you.

7 July 2021

RE Oakland Harvesters Proposed Storage Facility

Dear White Lake Board, residents and township staff.

First of all please understand that Oakland Harvesters is a relatively new and growing company, a seasonal operating company, and we do not have unlimited funds for this or any other projects. The sole plan here, just as families buy a house vs rent, is to put company funds into something that will turn into equity over time, rather than throw money away on exorbitant commercial rental space.

This letter is meant to address any questions, and/or deficiencies on our current proposal.

Grading/Paving Item #4 Our plan specifies 18' parking spaces, and no cars are 20' in length, so there will be no vehicle overhang meaning the proposed sidewalk should be fine.

Grading/Paving Item #6 We will indeed add a sidewalk out front, and look forward to doing so if/when it becomes logical. Right now it would be a sidewalk to nowhere, and an added expense we would like to put off until it is really needed.

Item 2 Proposed Use: The proposed use of our building will be the inside storage of our new harvesters and support equipment. We work roughly 4 months a year, and Michigan has brutal winters that is rough on steel equipment and engines. We've also experienced theft and vandalism which will be remedied with secure inside storage. We will be storing our new equipment inside, and the old outside until it's sold or decommissioned.

Item 3 Building Placement; Architecture and Design: We only wish to pave the absolute minimum required, and prefer other than the entrances and front (south side) of the building, that the rest be gravel drive which would allow for more drainage, and far less of an expense. We do indeed need to drive around the back. All required elevations and landscape plans are in the works for the next stages.

4. Site Circulation and Parking: During Peak season we have 7 employees, and most drive directly to the waterway we happen to be working on. There is no storefront or customer interface at the business, our customers live on lakes, and we go to them to survey and contract business, after they have called

or contacted us thru our website. We are not manufacturing anything and need only the required minimum parking spaces deemed necessary for our business.

9. Trash Disposal We do not expect to create much trash, no trash service will be needed and what little is generated I will handle personally.



INNOVATIVE IDEAS  
EXCEPTIONAL DESIGN  
UNMATCHED CLIENT SERVICE

May 26, 2021

Sean O' Neil, Director  
Community Development Department  
Charter Township of White Lake  
7525 Highland Road  
White Lake, Michigan 48383

**RE: Oakland Weed Harvesters - Preliminary Site Plan Review- 2<sup>nd</sup> Review**

DLZ # 2045-7141-06

Dear Mr. O' Neil,

Our office has reviewed the above-mentioned revised plans prepared by Kieft Engineering, Inc. and dated November 19, 2020. These plans were reviewed for general engineering feasibility and conformance with the Township Engineering Design Standards. We offer the following comments for your consideration:

**Site Improvement Information-**

- A single story 9,000 sq.ft. building for office and equipment maintenance.
- Associated parking and open area for service vehicle maneuvering. Parking and open areas proposed to be asphalt paved.
- Two entrances off White Lake Road.
- One open sedimentation/detention basin with outlet.
- Site to be serviced by well for water and septic for sanitary.

Please note that comments from our October 29,2020 review are in *italics*. Responses to those comments are in **bold**. New comments are in standard typeface.

## Preliminary Site Plan Comments-

### General

1. *There is a Master Deed as part of the Prospectors Square overall plan. The requirements of this deed will need to be met. Our office will further review compliance with Master Deed requirements at the time of Final Site Plan/Final Engineering Plan submittal. **Comment remains as a notation.***
2. *Provide verification that the Old White Lake Road easement that previously ran through this property has been abandoned. **Comment addressed, design engineer indicated the property in question has been recorded as the "Prospectors Square" condominium back in 2001 and provided a copy of the Exhibit B to the Master Deed. The Exhibit B document does not show the Old White Lake Road easement.***

### Grading/Paving

1. *The plan proposes gravel as the surface material for the parking and vehicle traffic areas in lieu of pavement material such as concrete or asphalt. Per White Lake Township Zoning Ordinance 5.11 Q. xi., all parking areas are required to be paved unless a variance is obtained. Should a variance not be approved, and the applicant required to pave the areas in question, would result in an increased area and volume required for the detention basin. **Comment addressed. All parking and vehicle traffic areas are now proposed to be paved. The detention basin calculations have now been updated to reflect this change; we are satisfied with the preliminary basin design calculations.***
  2. *Maneuvering lane between parking spaces does not meet the required 24' width per Township Ordinance. **Comment addressed. Width of maneuvering lane is 24'.***
  3. *ADA spaces and ramp will need to be provided per Township requirements. ADA parking spaces and ramps will need to be paved and meet all requirements of the Township and ADA. **Comment addressed. ADA parking spaces and ramps have now been provided.***
  4. *Per Township Zoning Ordinance 5.11 Q. xvii. Concrete curbing or a raised sidewalk or parking bumpers shall be placed 3' off any building with adjacent parking. Please provide one of the above on plan. **A 4' wide raised sidewalk has been added between the building and the parking stalls, however Township Zoning Ordinance 5.11 Q. xv indicates a 7 foot wide sidewalk is required if the sidewalk is intended for pedestrian use to account for the subsequent vehicle overhang.***
  5. *We note that Township Zoning Ordinance 5.19 B.V indicates that all required landscape areas which abut vehicular drives, parking, or other use areas shall be separated from the vehicular use area with a 6 inch minimum concrete curb. We defer to the Planning Department or Planning Commission on how this should be applied for this use. We note the plans propose sheet drainage to the sediment forebay which would not allow for continuous curb along the detention basin.*
-

6. We note that the plans do not propose a sidewalk along the White Lake Road Frontage, we defer to the Planning Department regarding this as a requirement for this development.

#### Sanitary Sewer

1. *Oakland County Health Department will need to approve and permit septic field for this property. We defer to the Health department regarding the requirement for an oil and grease separator upstream of the septic tank for building floor drains due to the nature of the proposed use.* **Comment remains as a notation.**

#### Watermain

1. *We defer to the Township Fire Department with regard to fire suppression and access requirements.* **Comment remains as a notation.**
2. *A well is proposed as the source of water for this site. Per our files, there exists a Water Supply Agreement that states that wells are to be abandoned if water main becomes available for use. We defer to the Township as the whether this agreement was ever signed. Please note that our files indicate that this agreement was received by the Township on December 18, 2000.* **Comment remains as a notation.**

#### Stormwater Management

1. *The discharge for the proposed detention basin is not taking the intended easement path toward the ultimate outlet in the rear of the overall Prospectors Square development. This is per the Prospectors Square plans, Master Deed and Exhibit B documents. Furthermore, the proposed point of the basin discharge suggests that flows will enter on to off site property located in Springfield Township which would not be allowed unless a drainage easement is secured. This also applies to future flows from proposed basin spillway location.* **Comment addressed, design engineer has adjusted the outlet location and shown drainage flow lines within the drainage easement, this meets the requirements of PSP review. At the time of Final Site Plan/Final Engineering Plan submittal further detail will be required to demonstrate that the basin discharge will be confined within the drainage easement.**
2. *The proposed detention basin shall have a sediment forebay consistent with Township and Oakland County standards.* **Comment addressed. A sediment forebay is now proposed.**

#### Recommendation-

The comments that remain outstanding are related to the sidewalk between the building and the parking area, sidewalk along the site frontage, and curbing around the paving limits. All of these items have been deferred to the Planning Department or Planning Commission for interpretation or discussion. The plan set

---



INNOVATIVE IDEAS  
EXCEPTIONAL DESIGN  
UNMATCHED CLIENT SERVICE

demonstrates engineering feasibility appropriate for this level of review. We recommend approval of the preliminary site plan subject to successful resolution of the above referenced items.

Please contact our office should you have any questions.

Sincerely,

DLZ Michigan

Michael Leuffgen, P.E.  
Department Manager

Victoria Loemker, P.E.  
Senior Engineer

Cc: Justin Quagliata, Community Development, *via email*  
Hannah Micallef, Community Development, *via email*  
Aaron Potter, DPS Director, White Lake Township, *via email*  
John Holland, Fire Marshall, White Lake Township, *via email*





# MCKENNA

June 24, 2021

Planning Commission  
Charter Township of White Lake 7525 Highland Road  
White Lake, MI 48383

**Subject:** Oakland Weed Harvesters  
Preliminary Site Plan Review #2  
Zoned: Light Manufacturing (LM) District

**Applicant(s):** Oakland Harvesters

**Location:** North side of White Lake Road, west of Old White Lake Road and east of Orr Banks

Dear Planning Commissioners:

We have received an application for preliminary site plan review for tax parcel 12-01-127-001, dated November 19, 2020 consisting of approximately 2.00 acres, currently zoned Light Manufacturing (LM). Currently vacant, the applicant has proposed a 9,000 square foot light manufacturing building, and associated parking lot and storage area for equipment, pallets, fleet vehicles and an 8' x 30' or 40' dumpster. Mack industries is located across the street.



**Source:** Oakland County Property Gateway

**HEADQUARTERS**  
235 East Main Street  
Suite 105  
Northville, Michigan 48167

☎ 248.596.0920  
☎ 248.596.0930  
[MCKA.COM](http://MCKA.COM)

Communities for real life.



**COMMENTS**

1. **Existing Conditions.** The conditions of the site and the surrounding area are summarized below:

Location	Existing Land Use	Master Plan	Existing Zoning
Site	Vacant	Light Manufacturing	Planned Commerce
North	Commercial	Springfield Township	Springfield Township
East	Vacant	Light Manufacturing	Planned Commerce
South	Mack Industries	Light Manufacturing	Planned Commerce
West	Vacant	Light Manufacturing	Planned Commerce

2. **Proposed Use.** The applicant is proposing a one-story, 9,000 SF manufacturing use with associated office space (approximately 2,250 square feet). Manufacturing is permitted in the LM district and the applicant listed light manufacturing as the use on the application materials. However, several of the proposed uses require special land use approval. These uses include outdoor storage of pallets, materials and fleet vehicles as well as automobile heavy repair facilities. A special land use review is provided under separate cover. To facilitate the approval process, **the applicant should provide a narrative specifically outlining the scope of these uses.** The narrative should be included as an addendum to any site plan and/or special land use materials and any approvals should reference the addendum for clarity in the future.

3. **Building Placement; Architecture and Design.** The site is of a conforming size and the building complies with all of the setback requirements for the LM District as modified by the approved site condominium (Prospector’s Square) site condominium documents. **The petitioner needs to provide exact calculations of lot coverage and building heights on the plans for final site plan approval. Additionally, the Prospector’s Square site condominium documents should be provided and attached to the supporting plans prior to final site plan approval.**

Applicable Requirement	Required by the Zoning Ordinance in the LM District	Proposed
Front Yard Setback	30 feet **	45 feet
Side Yard Setback	20 feet	121 feet (west) 75 feet (east)
Rear Yard Setback	40 feet **	79 feet
Building Height	40 feet or two stories	Undetermined
Minimum Lot Area	1 acre	2 acres
Lot Coverage	30%	Undetermined – approx. 10.3%

Additionally, building elevations and floor plans were not provided with the second site plan submission package but are required as part of the preliminary site plan stage to confirm compliance with the building height requirement and general standards for special land uses. Finally, we note that the applicant has proposed a large amount of impervious surface in the form of a drive lane around the site. Unless it is necessary for large vehicle maneuvering, we recommend the applicant reduce the width of the drive lanes and decrease the total paving on site.

4. **Site Circulation and Parking.** Manufacturing uses are required to have five (5) parking spaces plus one (1) for every one and one half (1 1/2) employees. The petitioner states that he will have eight (8) employees. This should be noted on the site plan. A total of 11 spaces are required. The petitioner is proposing 16 spaces. However; a portion of the parking along the White Lake Road frontage is in the required front yard setback. **These spaces should be removed.**

5. **Pedestrian Circulation.** Per Section 5.21 of the Zoning Ordinance, a six (6) foot wide public sidewalk is required along White Lake Road. The applicant has not proposed such a pathway on the submitted site plan.



**The addition of the required six-foot public sidewalk should be condition of approval for the site plan.**

6. **Landscaping and Screening.** A landscape plan was not provided with the submitted application materials, and is required for final site plan review. At that time the landscape plan will be reviewed for compliance with therequirements in Section 5.19 of the ordinance, including a required A-1 greenbelt along the road right-of-way.
7. **Lighting.** Section 5.18(G) of the Zoning Ordinance includes the standards for outdoor lighting. Currently, the site plan does not indicate any lighting for the site. **If exterior lighting is planned for the site, a lighting plan showing compliance with the standards within section 5.18(G) should be submitted at the time of the final site plan.**
8. **Signs.** Section 5.9 of the Zoning Ordinance regulates signs. The site plan indicates one sign along the White Lake Road frontage. **A separate sign permit application would need to be submitted for administrative review for any future signage.**
9. **Trash Disposal.** The petitioner verbally indicated that they will have a refuse container, approximately 8' x 30' or 40'. No trash enclosure area is noted on the site plan. **If a dumpster or similar receptacle is planned for the site, the location and size should be noted on the site plan.** Dumpsters cannot be located closer to the front lot line than the principal building. Like building elevations, screening details should be provided and must comply with the standards insection 5.19(N) of the Zoning Ordinance for location, screening method, and enclosure standards.

#### **RECOMMENDATION**

As noted in our review letter, there are several outstanding issues. We recommend the project be tabled to allow the applicant to address these outstanding issues based on direction from the Planning Commission.

However, if the Planning Commission is comfortable with the proposed project, then we recommend that the Planning Commission approve the project subject to the issues identified above and the submission of revised plans for administrative review.

If you have any questions about this report or require additional information, please do not hesitate to contact us.

Respectfully submitted,

**McKENNA**

*Kathleen Jackson*

Kathleen Jackson  
Senior Principal Planner

cc: Mr. Sean O'Neal, AICP  
Mr. Justin Quagliata  
Ms. Hannah Micallef





# MCKENNA

June 24, 2021

Planning Commission  
Charter Township of White  
Lake 7525 Highland Road  
White Lake, MI 48383

**Subject:** Oakland Harvesters  
Special Use Review #1  
Zoned: Light Manufacturing (LM) District

**Applicant(s):** Oakland Harvesters

**Location:** North side of White Lake Road, west of Old White Lake Road and east of Orr Banks

Dear Planning Commissioners:

We have received an application for a special land use for tax parcel 12-01-127-001, consisting of approximately 2.00 acres, currently zoned Light Manufacturing (LM) for outdoor storage of fleet vehicles (sec.4.37), pallets, containers, materials, and products (sec. 4.39). Currently vacant, the applicant has proposed a 9,000 square foot light manufacturing building, and associated parking lot. Mack industries is located across the street.



**Source:** Oakland County Property Gateway

**HEADQUARTERS**  
235 East Main Street  
Suite 105  
Northville, Michigan 48167

☎ 248.596.0920  
☎ 248.596.0930  
[MCKA.COM](http://MCKA.COM)

Communities for real life.



The applicant has also submitted an application for site plan approval which has been reviewed separately.

**GENERAL STANDARDS FOR ALL SPECIAL LAND USES.**

Section 6.10 of the Zoning Ordinance establishes general review standards for all uses requiring special use approval. We have reviewed the proposed project according the these standards and offer the following findings for your consideration:

1. The proposed special land use shall be of such location, size and character that it will be in harmony with the appropriate and orderly development of the surrounding neighborhood and/or vicinity and applicable regulations of the zoning district in which it is to be located.

*We find that the proposed use is appropriate in location, size and character, and will be harmonious with the surrounding light manufacturing uses. This finding is subject to the applicant addressing the outstanding items in the site plan review letter dated June 24, 2021 and other relevant items identified during the review process and the Planning Commission's consideration.*

2. The proposed use shall be of a nature that will make vehicular and pedestrian traffic no more hazardous than is normal for the district involved, taking into consideration vehicular turning movements in relation to routes of traffic flow, proximity and relation to intersections, adequacy of sight distances, location and access of off-street parking and provisions for pedestrian traffic, with particular attention to minimizing child-vehicle interfacing.

*We find that the proposed use will not generate any traffic that is inconsistent with traffic generated from typical light manufacturing uses. This finding is subject to the applicant addressing the outstanding items addressed in our site plan review letter dated June 24, 2021 including the provision of appropriate sidewalks.*

3. The proposed use shall be designed as to the location, size, intensity, site layout and periods of operation of any such proposed use to eliminate any possible nuisance emanating therefrom which might be noxious to the occupants of any other nearby permitted uses, whether by reason of dust, noise, fumes, vibration, smoke or lights.

*We find that the proposed use is appropriate in location, size and intensity, and will be harmonious with the surrounding light manufacturing uses. This finding is subject to the applicant addressing the outstanding items in the site plan review letter dated June 24, 2021 and other relevant items identified during the review process and the Planning Commission's consideration.*



4. The proposed use shall be such that the proposed location and height of buildings or structures and location, nature and height of walls, fences and landscaping will not interfere with or discourage the appropriate development and use of adjacent land and buildings or unreasonably affect their value.

*Provided the applicant address the screening requirements identified in our site plan review letter dated June 24, 2021 and other relevant items identified during the review process and the Planning Commission's consideration we find that the proposed outdoor storage will not discourage the appropriate development of surrounding land.*

5. The proposed use shall relate harmoniously with the physical and economic aspects of adjacent land uses as regards prevailing shopping habits, convenience of access by prospective patrons, continuity of development, and need for particular services and facilities in specific areas of the Township.

*We find the proposed use to be appropriate provided they address the screening of outdoor storage to the satisfaction of the Planning Commission.*

6. The standards of density and required open spaces for the proposed special land use shall be at least equal to those required by this Ordinance in the Zoning District in which the proposed special land use is to be located.

*This standard does not apply to the proposed use.*

7. The public services and facilities affected by a proposed special land use or activity shall be capable of accommodating increased service and facility loads caused by the land use or activity.

*We find that the proposed use is consistent in demand for public services with other light industrial uses permitted in the LM district.*

8. Protection of the natural environment and conservation of natural resources and energy.

*The Township has designated the LM district in an area that is not likely to result in negative impacts on natural features.*

9. The proposed use is necessary for the public convenience at the proposed location.

*The proposed use of outdoor storage of fleet vehicles and other equipment relating to the applicant's business of aquatic weed removal is appropriate at this location based on the continuous demand for maintaining the water quality in and around the Township.*



10. The proposed use is so designed, located, planned and to be operated that the public health, safety and welfare will be protected.

*Provided the applicant address the screening requirements identified in our site plan review letter dated June 24, 2021 and other relevant items identified during the review process and the Planning Commission's consideration we find that the proposed outdoor storage can be operated in a manner that will protect the health, safety, and welfare of public.*

11. The proposed use shall not cause substantial injury to the value of other property in the neighborhood in which it is to be located and will not be detrimental to existing and/or other permitted land uses in the zoning district.

*We find that the proposed use will not cause any substantial injury to the value of other light industrial uses permitted in the LM district.*

### **Recommendation**

Based on our review of the Special Land Use application for Oakland Harvesters, we find the proposed use of outdoor storage of fleet vehicles (sec.4.37), and outdoor storage of pallets, containers, materials, and products (sec. 4.39) to be consistent with the standards contained in Section 6.10 of the White Lake Zoning Ordinance.

This finding is subject to the applicant addressing the outstanding issues identified in our site plan review letter dated June 24, 2021 and other relevant items identified during the review process to the satisfaction of the Planning Commission.

If you have any questions about this report or require additional information, please do not hesitate to contact us. Respectfully submitted,

**McKENNA**

*Kathleen Jackson*  
Kathleen Jackson  
Senior Principal Planner

cc: Mr. Sean O'Neal, AICP  
Mr. Justin Quagliata  
Ms. Hannah Micallef



## Site / Construction Plan Review

To: Sean O'Neil, Planning Department Director

Date: 06/01/21

Project: Oakland Weed Harvesters

File #: Not Shown

Date on Plans:

---

The Fire Department has the following comments with regards to the 2nd review of preliminary site plans for the project known as Oakland Weed Harvesters:

1. The use description of this proposed building is primarily maintenance garage (S-1). Note an excerpt from the International Fire Code (IFC)  
Section 903.2.9.1 Repair Garages. An automatic sprinkler system shall be provided throughout all buildings used as repair garages in accordance with section 406.8 of the International Building Code, as shown.  
  
This applies to a group S-1 (repair garage) where the fire area exceeds 5,000 square feet (as shown under item #4 of this section).  
With regards to this comment - **In order to provide a complete and accurate review, The applicant will need to submit additional information pertaining to the size of the repair garage, and separation between areas within the building.**
2. **Hydrant Well.** For new construction not providing a water distribution system, information regarding the building construction type, and size (including height) shall be submitted to the Fire Department during the site plan phase of the project. The fire Department will base its decision on flow requirements, and the proposed building location. If the calculated flow requirements exceed Fire Department capabilities, a Hydrant Well shall be required. If required, the Hydrant Well detail shall be shown on the site and construction plan submittals. **Pending**
3. **Proposed access.**
  - a. The access drive shall be designed and maintained to support the imposed loads of fire apparatus and shall be surfaced so as to provide all weather driving capabilities.
  - b. The required turning radius shall accommodate the largest Fire Department apparatus (40').
  - c. The angle of approach / departure to and from White Lake Road shall not exceed 8 degrees.  
**Pending (Applicant written response needed).**

John Holland  
Fire Chief  
Charter Township of White Lake  
(248)698-3993  
[jholland@whitelaketwp.com](mailto:jholland@whitelaketwp.com)



# Memo

**To:** Sean O'Neil, Planning

**From:** Jeanine A Smith

**Date:** May 17, 2021

**Re:** Project Name: Oakland Weed  
Harvesters

Parcel Number: 12-01-127-001

---

**Comments:** No Comment

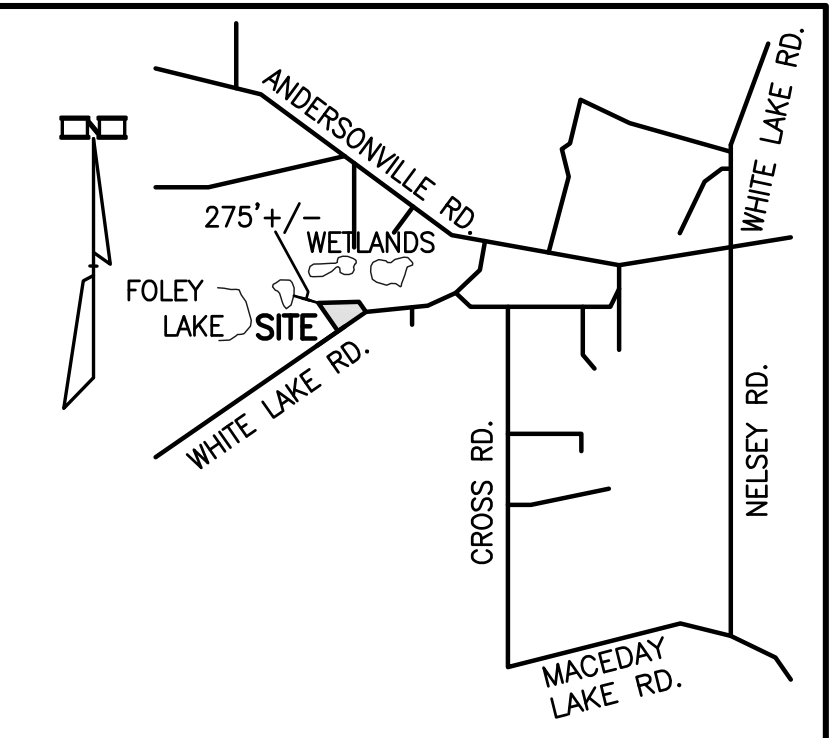
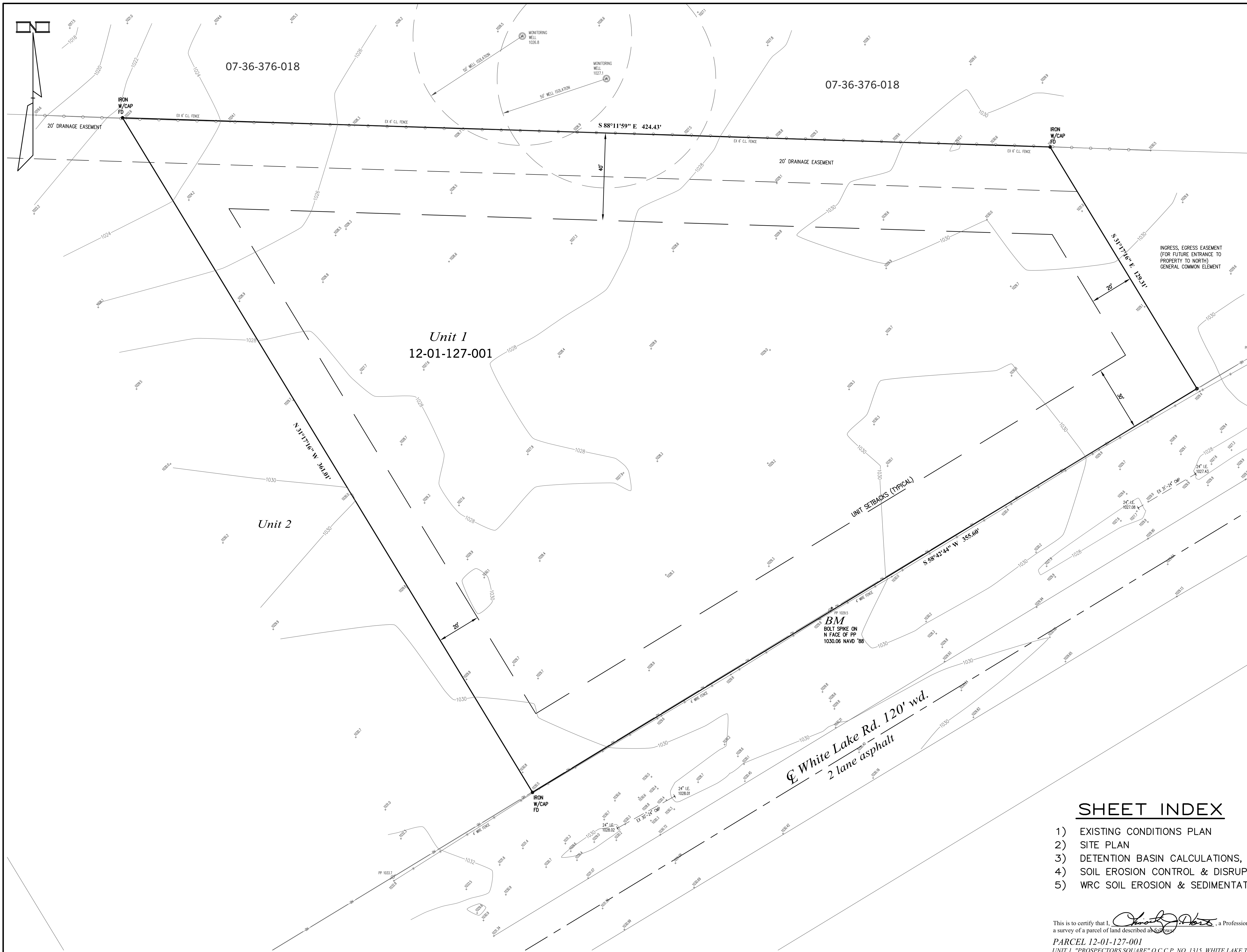

LOCATION MAP  
SCALE 1" = 2000'

LEGEND

EXISTING	
	STORM SEWER
	SANITARY SEWER
	WATERMAIN
	GAS MAIN
	ELEC. TELE. CABLE
	STORM MANHOLE
	CATCH BASIN
	INLET
	REARYARD CATCH BASIN
	END SECTION
	SANITARY MANHOLE
	GATE VALVE AND WELL
	HYDRANT
	CONTOURS

Notes:

- ALL EXISTING UTILITIES SHOWN ON THIS TOPOGRAPHIC SURVEY HAVE BEEN TAKEN FROM VISUAL OBSERVATION, AND RECORD MAPPING, WHERE AVAILABLE. NO GUARANTEE IS MADE, OR SHOULD BE ASSUMED, AS TO THE COMPLETENESS OR ACCURACY OF THE UTILITIES SHOWN ON THIS DRAWING. PARTIES UTILIZING THIS INFORMATION SHALL FIELD VERIFY THE ACCURACY AND COMPLETENESS OF OVERHEAD AND UNDERGROUND UTILITIES PRIOR TO CONSTRUCTION ACTIVITIES.
- ARCHITECT / BUILDER IS RESPONSIBLE FOR CONFIRMING BUILDING SETBACKS.

CONDO SETBACKS:

SETBACKS:  
FRONT - 30 FEET  
SIDE - 20 FEET  
REAR - 40 FEET

BENCHMARK:

BOLT SPIKE ON N FACE OF PP  
ELEVATION = 1030.06 NAVD '88

SHEET INDEX

- EXISTING CONDITIONS PLAN
- SITE PLAN
- DETENTION BASIN CALCULATIONS, DETAILS & NOTES
- SOIL EROSION CONTROL & DISRUPTION PLAN
- WRC SOIL EROSION & SEDIMENTATION CONTROL DETAILS (1 OF 1)

This is to certify that I, *Timothy J. Hart*, a Professional Land Surveyor, have this date made a survey of a parcel of land described as follows:  
**PARCEL 12-01-127-001**  
 UNIT 1, "PROSPECTORS SQUARE" O.C.C.P. NO. 1315, WHITE LAKE TOWNSHIP, OAKLAND COUNTY, MICHIGAN.

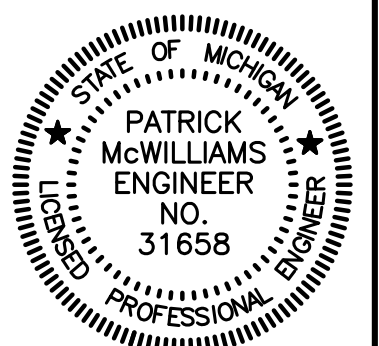

DATE	ISSUE
10-12-2020	INCREASED BUILDING SIZE PER CLIENT (10-8-2020)
11-19-2020	REVISIONS PER TWP-DLZ (10-29-2020)

PROPRIETOR:  
OAKLAND HARVESTERS LLC,  
9589 MANDON ROAD  
WHITE LAKE, MI 48386  
(248) 595-3247

THIS DRAWING IS THE PROPERTY OF KIEFT ENGINEERING, INC. AND MAY NOT BE USED, REPRODUCED OR PUBLISHED, IN PART OR IN WHOLE, WITHOUT EXPRESSED WRITTEN PERMISSION FROM KIEFT ENGINEERING, INC.



**KIEFT ENGINEERING, INC.**  
 PROFESSIONAL ENGINEERS AND PROFESSIONAL SURVEYORS  
 5852 SOUTH MAIN STREET, SUITE 1, CLARKSTON, MICHIGAN 48346  
 PHONE (248) 625-5251 www.kiefteng.com FAX (248) 625-7110

DATE	CKD. BY	DATE
2-20-2020		



**EXISTING CONDITIONS PLAN**  
 PARCEL NO. 12-01-127-001  
 WHITE LAKE TOWNSHIP, OAKLAND COUNTY, MICHIGAN

SCALE	1" = 20'
SHEET	1 OF 5
KE 2019.352	

OAKLAND HARVESTERS SITE PLAN



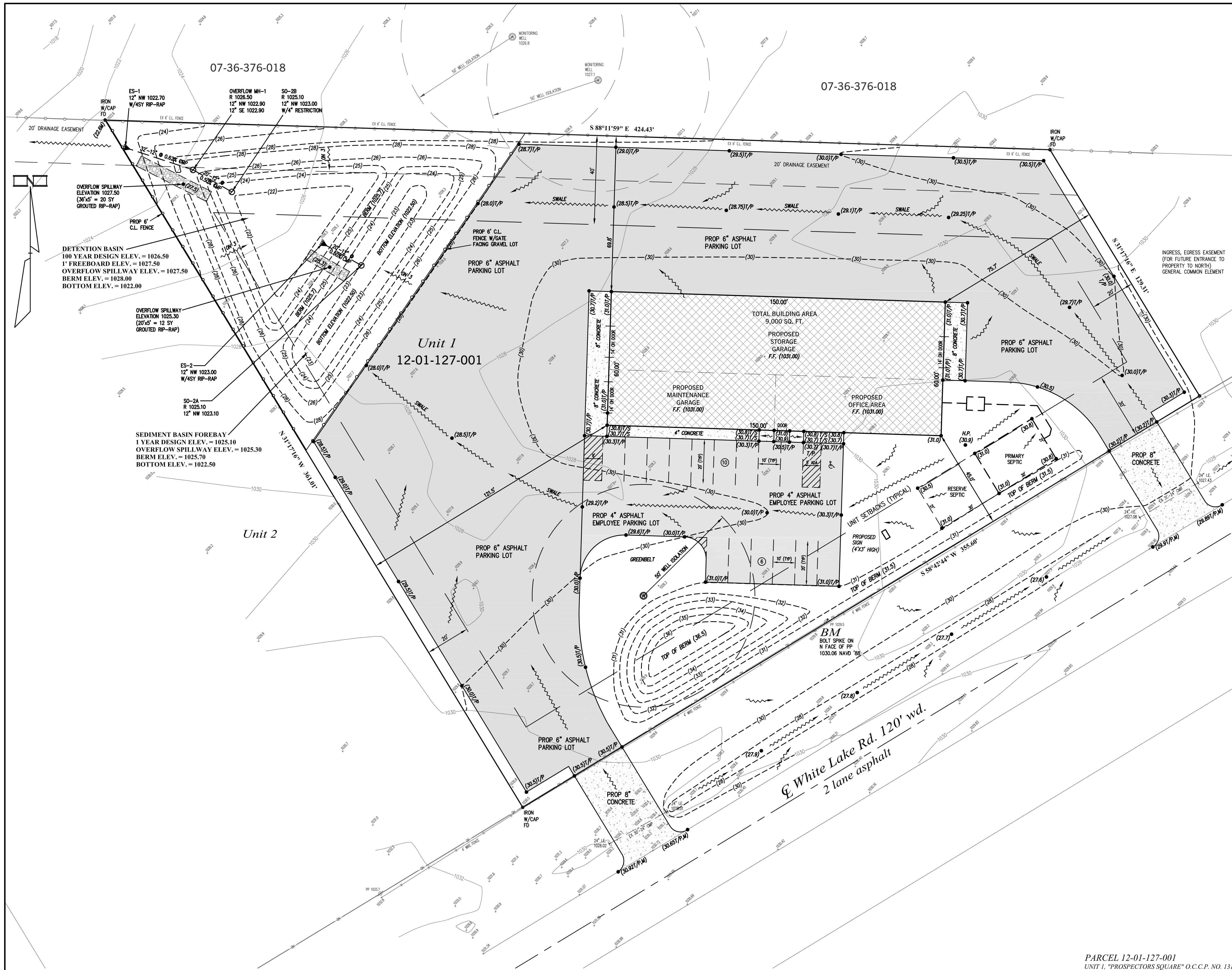

EXISTING	LEGEND	PROPOSED
---	STORM SEWER	---
---	SANITARY SEWER	---
---	WATERMAIN	---
---	GAS MAIN	---
---	ELEC. TELE. CABLE	---
---	GRADES	(99.0)
---	STORM MANHOLE	□
---	CATCH BASIN	□
---	INLET	□
---	REARYARD CATCH BASIN	□
---	END SECTION	□
---	SANITARY MANHOLE	□
---	GATE VALVE AND WELL	□
---	HYDRANT	□
---	CONTOURS	(40)
---	POWER POLE	□
---	LIGHT POLE	□
---	SAVE TREE	(S)
---	TOP OF PAVEMENT	T/P
---	TOP OF CURB ELEVATION	T/C
---	TOP OF SIDEWALK ELEVATION	T/S
---	MATCH EXISTING ELEVATION	(M)
---	WETLANDS BOUNDARY	---
---	25' WETLANDS BUFFER	---
---	STANDARD CURB	---
---	REVERSE CURB	---

- Notes:**
- ALL EXISTING UTILITIES SHOWN ON THIS TOPOGRAPHIC SURVEY HAVE BEEN TAKEN FROM VISUAL OBSERVATION, AND RECORD MAPPING, WHERE AVAILABLE. NO GUARANTEE IS MADE, OR SHOULD BE ASSUMED, AS TO THE COMPLETENESS OR ACCURACY OF THE UTILITIES SHOWN ON THIS DRAWING. PARTIES UTILIZING THIS INFORMATION SHALL FIELD VERIFY THE ACCURACY AND COMPLETENESS OF OVERHEAD AND UNDERGROUND UTILITIES PRIOR TO CONSTRUCTION ACTIVITIES.
  - ARCHITECT / BUILDER IS RESPONSIBLE FOR CONFIRMING BUILDING SETBACKS.

**CONDO SETBACKS:**  
 SETBACKS:  
 FRONT - 30 FEET  
 SIDE - 20 FEET  
 REAR - 40 FEET

**BENCHMARK:**  
 BOLT SPIKE ON N FACE OF PP  
 ELEVATION = 1030.06 NAVD '88

PARCEL 12-01-127-001  
 UNIT 1, "PROSPECTORS SQUARE" O.C.C.P. NO. 1315, WHITE LAKE TOWNSHIP, OAKLAND COUNTY, MICHIGAN.

DATE	ISSUE
10-12-2020	INCREASED BUILDING SIZE PER CLIENT (10-8-2020)
11-19-2020	REVISIONS PER TWP-DLZ (10-29-2020)

**PROPRIETOR:**  
 OAKLAND HARVESTERS LLC.  
 9589 MANDON ROAD  
 WHITE LAKE, MI 48386  
 (248) 595-3247

THIS DRAWING IS THE PROPERTY OF KIEFT ENGINEERING, INC. AND MAY NOT BE USED, REPRODUCED OR PUBLISHED, IN PART OR IN WHOLE, WITHOUT EXPRESSED WRITTEN PERMISSION FROM KIEFT ENGINEERING, INC.



**KIEFT ENGINEERING, INC.**  
 PROFESSIONAL ENGINEERS AND PROFESSIONAL SURVEYORS  
 9852 SOUTH MAIN STREET, SUITE 1, CLARKSTON, MICHIGAN 48346  
 PHONE (248) 625-5251 www.kiefteng.com FAX (248) 625-7110

DATE	CKD. BY	DATE
2-20-2020		



**SITE PLAN**  
 PARCEL NO. 12-01-127-001  
 WHITE LAKE TOWNSHIP, OAKLAND COUNTY, MICHIGAN

SCALE	1" = 20'
SHEET	2 OF 5
KE	2019.352

OAKLAND HARVESTERS SITE PLAN



**1 YEAR SEDIMENT FOREBAY CALCULATIONS (i.e. WITH OUTLET)**

ONSITE CONTRIBUTING AREA = 2.00 ACRES  
 OFFSITE CONTRIBUTING AREA = 0 ACRES  
 TOTAL CONTRIBUTING AREA = 2.00 ACRES  
 RUNOFF COEFFICIENT (C) = 0.71

$Q_A = (0.20)(2.00 \text{ ACRES}) = 0.40 \text{ C.F.S.}$

$Q_0 = \frac{Q_A}{(A)(C)} = \frac{0.40}{(2.00)(0.71)} = 0.28169$

$T = -25 + \sqrt{\frac{2,700}{Q_0}} = 72.90 \text{ MINUTES}$

$V_S = \frac{4,320 T}{T + 25} - 40 Q_0 T = 2,396 \text{ C.F./ACRE}$

$V_T \text{ REQ'D} = V_S (C)(A) = (2,396)(0.71)(2.00) = 3,403 \text{ C.F. REQ'D.}$

**VOLUME PROVIDED:**

- 1023.10: 400 SF
  - 1024.00: 1,800 SF
  - 1025.10: 2,700 SF
  - 1026.50: 3,600 SF
- 1,100 SF<sub>AV</sub> x 0.90' DEPTH = 990 CF  
 2,250 SF<sub>AV</sub> x 1.1' DEPTH = 2,475 CF  
 3,150 SF<sub>AV</sub> x 1.4' DEPTH = 4,410 CF (EXTRA STORAGE)
- SUB-TOTAL VOLUME = 3,465 CF PROVIDED (•1025.0), OK!  
 TOTAL VOLUME = 7,875 CF PROVIDED (•1026.5), OK!

**1 YEAR SEDIMENT BASIN**

1 YEAR REQUIRED VOLUME = 3,403 CF  
 1 YEAR STORM LEVEL = 1025.10

ORIFICE AREA REQUIRED  $A_o = \frac{(0.3988)(\text{AREA})(\sqrt{\text{HEIGHT}})}{172,800} = 0.0056 \text{ FT}^2$

THUS, IF AREA = 1,702 SF, HEIGHT = 2.02'; THEN A = 0.0056 FT<sup>2</sup>  
 0.0056 FT<sup>2</sup>/0.00545 FT<sup>2</sup> PER 1" DIA. HOLE = 1 HOLES  
 USE (4) 1" DIAMETER HOLES TO OFFSET FOR CLOGGING

**100 YEAR DETENTION BASIN CALCULATIONS (i.e. WITH OUTLET)**

ONSITE CONTRIBUTING AREA = 2.00 Acres  
 OFFSITE CONTRIBUTING AREA = 0.00  
 TOTAL CONTRIBUTING AREA = 2.00 Acres  
 RUNOFF COEFFICIENT (C) = 0.71

$Q_A = (0.20)(2.00 \text{ ACRES}) = 0.40 \text{ C.F.S.}$

$Q_0 = \frac{Q_A}{(A)(C)} = \frac{0.40}{(2.00)(0.71)} = 0.28169$

$T = -25 + \sqrt{\frac{10,562.50}{Q_0}} = 168.64 \text{ MINUTES}$

$V_S = \frac{16,500 T}{T + 25} - 40 Q_0 T = 12,470 \text{ C.F./ACRE}$

$V_T \text{ REQ'D} = V_S (C)(A) = (12,470)(0.71)(2.00) = 17,708 \text{ C.F. REQ'D.}$

**VOLUME PROVIDED:**

- 1023.00: 1,900 SF
  - 1025.00: 3,300 SF
  - 1026.50: 4,400 SF
- 2,600 SF<sub>AV</sub> x 2' DEPTH = 5,200 CF  
 3,850 SF<sub>AV</sub> x 1.5' DEPTH = 5,775 CF
- TOTAL VOLUME = 10,975 CF PROVIDED!

OVERALL TOTAL = 7,875 CF (FOREBAY) + 10,975 CF (BASIN) = 18,850 CF PROVIDED, OK!

**ORIFICE FORMULA**

$Q_A = 0.62 (A_o)(2gh)^{1/2}$

A<sub>o</sub> = AREA OF ORIFICE PIPE

$g = 32.2 \text{ FT./SEC}^2$

H = DEPTH OF BASIN ABOVE CENTERLINE OUTLET PIPE = 1025.00 - [1023.00 +  $\frac{4''}{2}$  = 1023.17] = 1.83'

$A_o = \frac{Q_A}{0.62 (2GH)^{1/2}} = \frac{0.40}{0.62 [(2)(32.2)(1.83)]^{1/2}} = 0.0594 \text{ S.F.}$

DIAMETER ORIFICE (D<sub>o</sub>):  $D_o = \sqrt{\frac{4(A_o)}{\pi}} = \sqrt{\frac{4(0.0594)}{\pi}} = 0.275 \text{ FT.} = 3.30 \text{ INCH}$   
 USE 4" RESTRICTION

**DETENTION BASIN**

EXISTING WATER ELEVATION = NONE  
 100 YEAR DESIGN HIGH WATER ELEVATION = 1026.50  
 1' FREEBOARD ELEVATION = 1027.50  
 STORAGE REQUIRED = 17,708 C.F.  
 STORAGE PROVIDED = 18,850 C.F.  
 STANDPIPE RIM = 1025.10  
 OVERFLOW MANHOLE RIM = 1026.50  
 EMERGENCY OVERFLOW SPILLWAY = 1027.50  
 TOP OF BERM = 1028.00  
 BOTTOM = 1022.00

**General Notes:**

1. DEVELOPER: OAKLAND HARVESTERS, LLC  
 9589 MANDON ROAD  
 WHITE LAKE, MICHIGAN 48386  
 (248) 595-3247 - ADAM KIRK
2. PROPERTY DESCRIPTION: PARCEL 12-01-127-001  
 UNIT 1, "PROSPECTORS SQUARE" O.C.C.P. NO. 1315, WHITE LAKE TOWNSHIP, OAKLAND COUNTY, MICHIGAN.
3. EXISTING ZONING: LM (LIGHT MANUFACTURING)
4. PROPOSED ZONING: LM (LIGHT MANUFACTURING)
5. PROPOSED USE: MAINTENANCE GARAGE & OUTDOOR STORAGE - TRUCKS/TRAILORS
6. SITE AREA: 2.00 ACRES
7. SETBACKS: EXISTING (PER CONDOMINIUM): PROVIDED SETBACKS:  
 FRONT 30 FEET 45.0 FEET  
 SIDES 20 FEET 121.5 FEET (WEST SIDE), 75.7 FEET (EAST SIDE)  
 REAR 40 FEET 69.8 FEET
8. WATER SUPPLY: INDIVIDUAL WELL (PER OAKLAND COUNTY HEALTH DEPARTMENT).
9. SEWAGE DISPOSAL: SEPTIC FIELD (PER OCHD)
10. SIGNAGE: PROPOSED PROJECT SIGNAGE ALONG WHITE LAKE ROAD PER TOWNSHIP REQUIREMENTS.
11. LANDSCAPE PLAN WILL BE SUBMITTED BY OTHERS, IF REQUIRED.
12. NO DUMPSTER IS PROPOSED
13. THIS PROJECT DOES NOT LIE WITHIN THE 100 YEAR FLOOD PLAIN.
14. BUILDING SIZE = 9,000 SF; LOT COVERAGE = 10.33%
15. PROPOSED # EMPLOYEES = 8  
 # PARKING SPACES = 16 (INCLUDES 1 ADA)

**QUANTITIES**

DISRUPTION AREA - 2.0 ACRES +/-

CLEARING: - ISOLATED TREES AND MINIMAL BRUSH

GRADING: CUTS/FILLS - 1,200 CY  
 IMPORT - 1,500 CY

**SOIL EROSION CONTROLS:**

SEED & MULCH - 0.80 ACRES  
 SILT FENCING - 880 LF  
 SILT FENCE GRAVEL FILTER - 1 EA  
 CONSTRUCTION STONE ACCESS - 120 SY

SEPTIC FIELD - 1 EA

WATER SERVICE - WELL - 1 EA

**STORM SEWER:**

12" CMP - 72 LF  
 12" END SECTION, CMP - 2 EA  
 OVERFLOW MANHOLE, 4' DIA., BAR GRATE COVER - 1 EA  
 SO-2 STAND PIPE, 3' DIA., BAR GRATE COVER - 2 EA  
 GROUTED RIP-RAP - 40 SY

**PAVEMENT & WALKS (ON-SITE):**

4" CONCRETE SIDEWALK ON 4" C.S.B. (VARIABLE WIDTH) - 60 SY  
 8" CONCRETE APRON ON 4" CSB - 114 SY  
 4" ASPHALT ON 6" 21AA (PARKING LOT) - 715 SY  
 6" ASPHALT ON 8" 21AA - 4,490 SY

**WHITE LAKE ROAD R.O.W.:**

8" CONCRETE APPROACH (PER R00C) - 270 SY

**SEDIMENT FOREBAY OUTLET FILTER (36" CMP) SO-2A STANDPIPE**

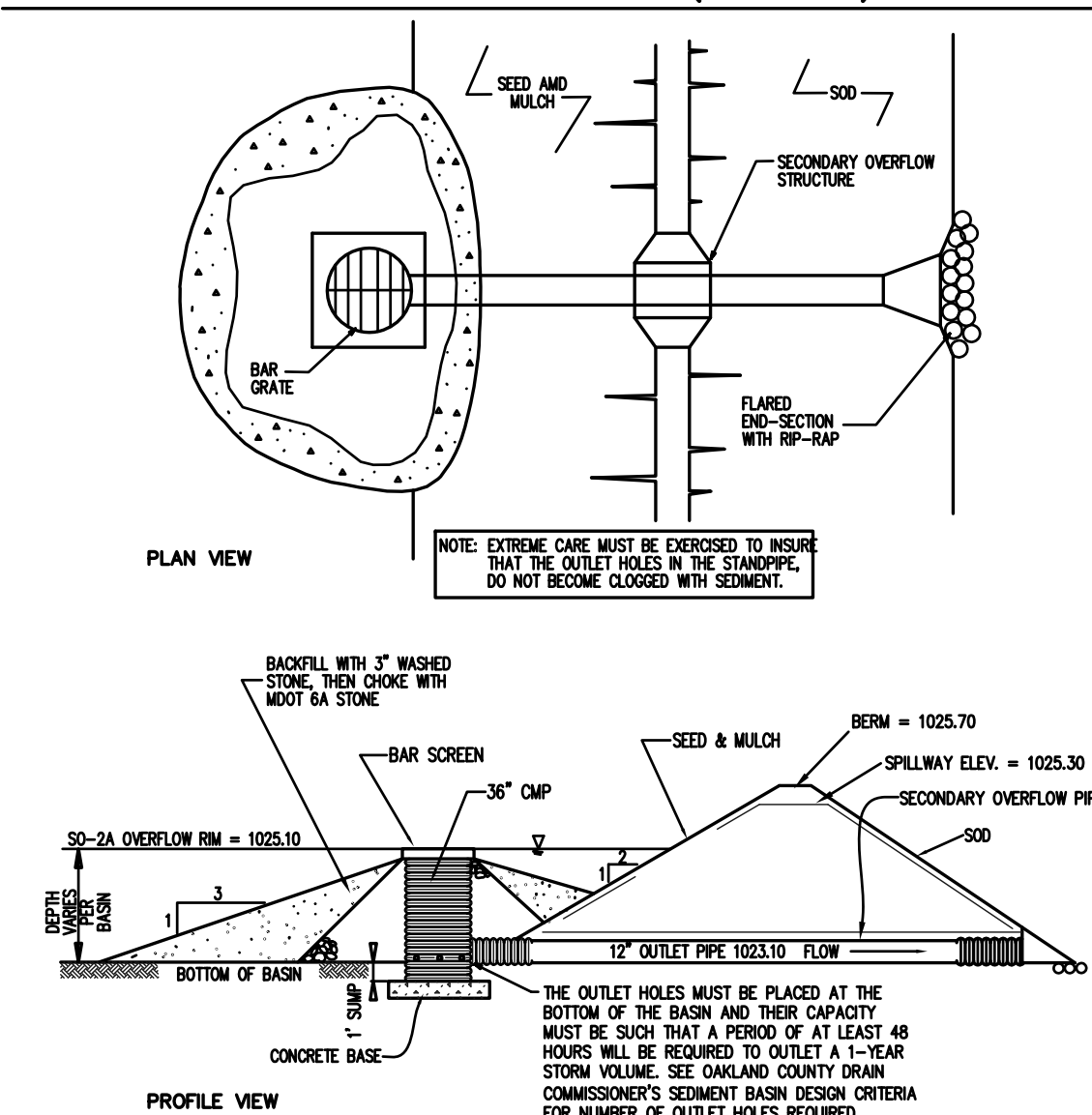

**DETENTION BASIN OUTLET FILTER (36" CMP) SO-2B STANDPIPE**

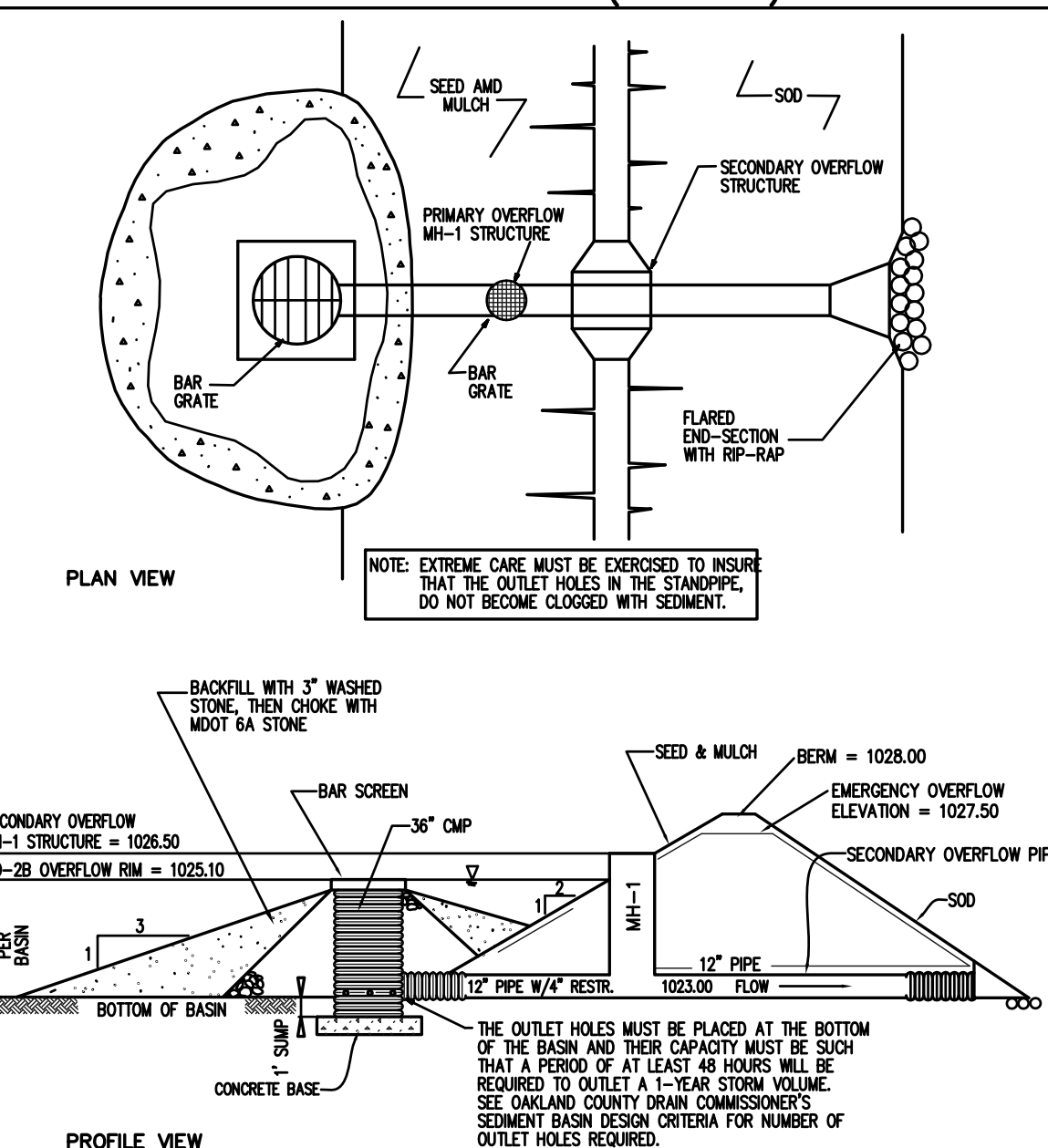

**"C" Calculation**

TOTAL SITE AREA = 2.00 ACRES

PAVEMENT: = 1.20 ACRES @ C = 0.80

GREENBELTS: 0.41 ACRES @ C = 0.20

ROOF AREA: 9,000 SF = 0.21 ACRES @ C = 0.90

BASIN AREA: 8,000 SF = 0.18 ACRES @ C = 1.00

$C = \left( \frac{1.20 \text{ ACRES}}{2.00 \text{ AC}} \times 0.80 \right) + \left( \frac{0.21 \text{ ACRES}}{2.00 \text{ AC}} \times 0.90 \right) + \left( \frac{0.41 \text{ ACRES}}{2.00 \text{ AC}} \times 0.20 \right) + \left( \frac{0.18 \text{ ACRES}}{2.00 \text{ AC}} \times 1.00 \right) = 0.705 \approx 0.71 \text{ OK!}$

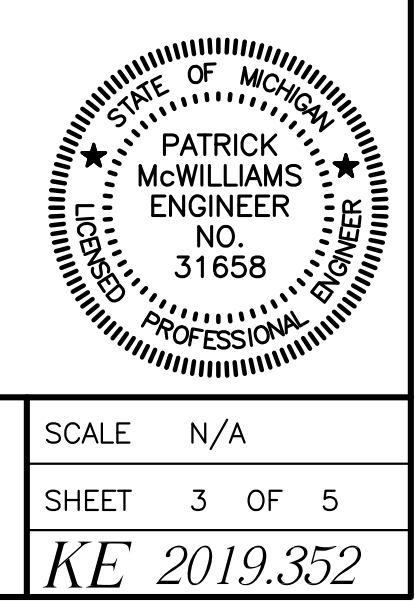
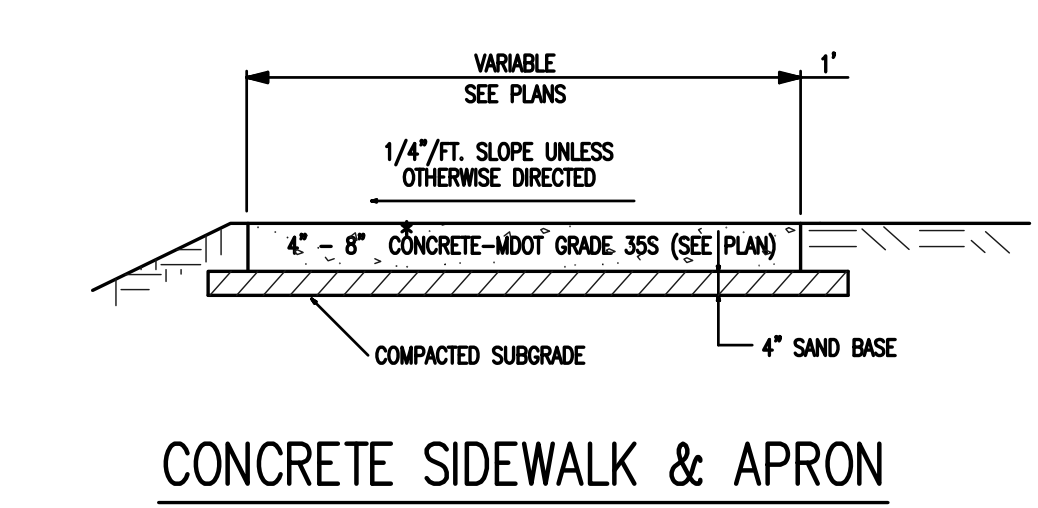
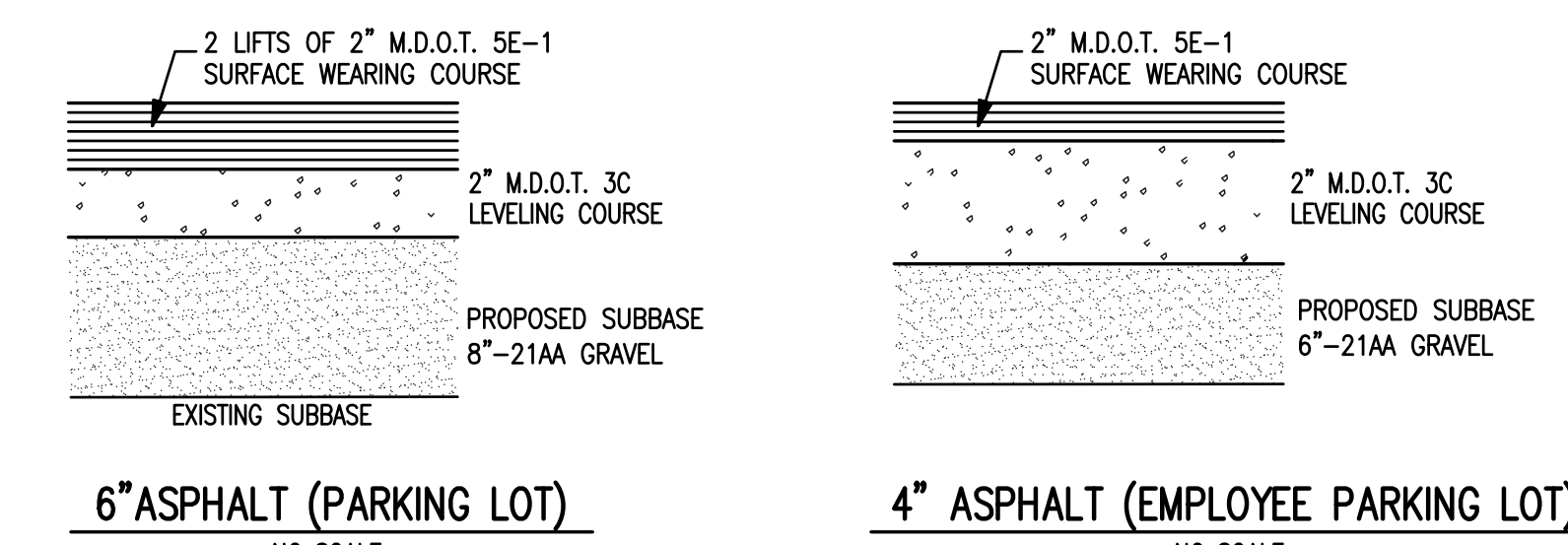

OAKLAND HARVESTERS SITE PLAN







