

DUMPSTER DETAIL

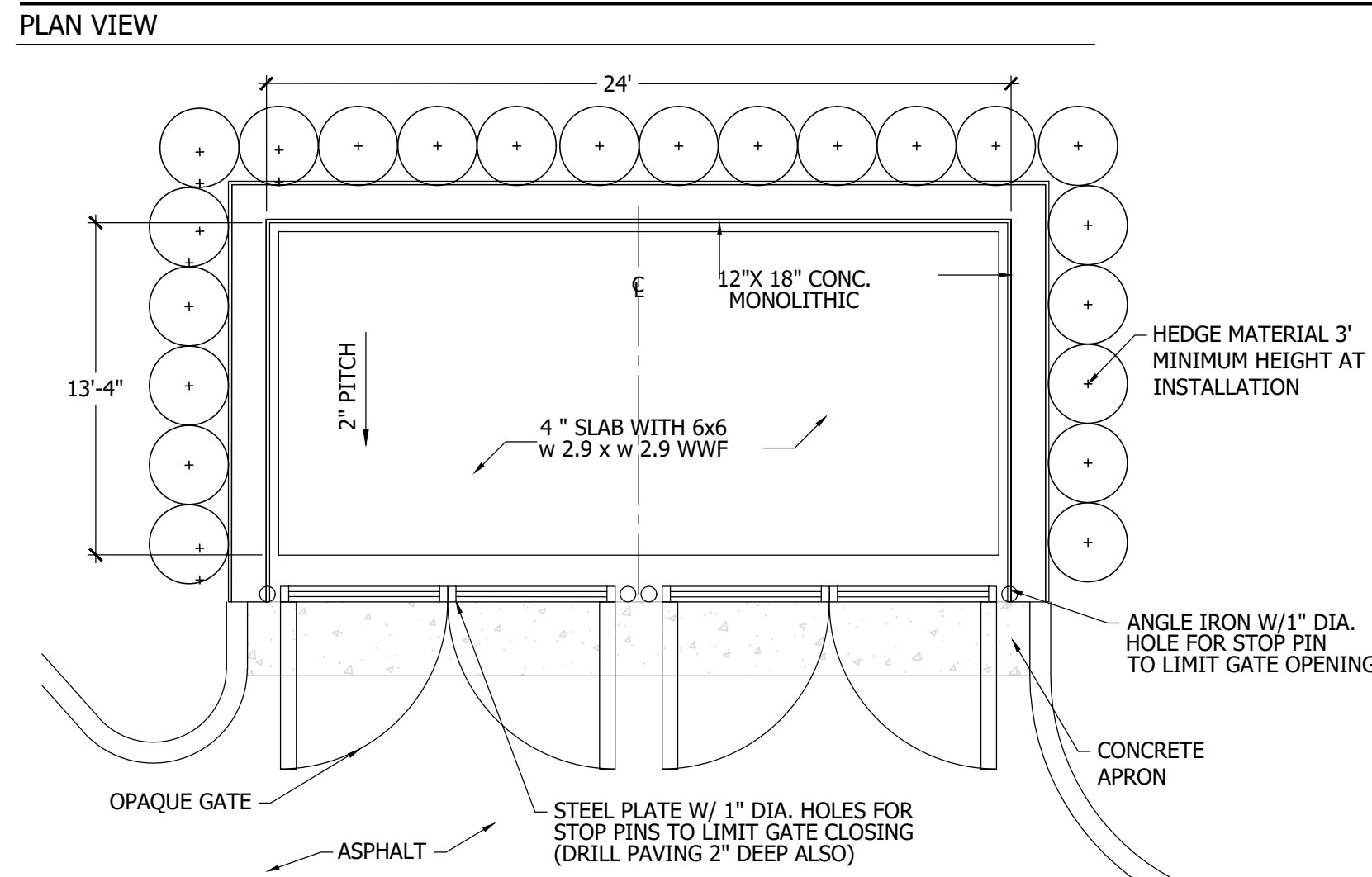

ELEVATION VIEW
NOTE: DUMPSTER MUST BE SCREENED PER SECTION 4.14 A) OF THE CITY OF WESTLAKE LANDSCAPE CODE

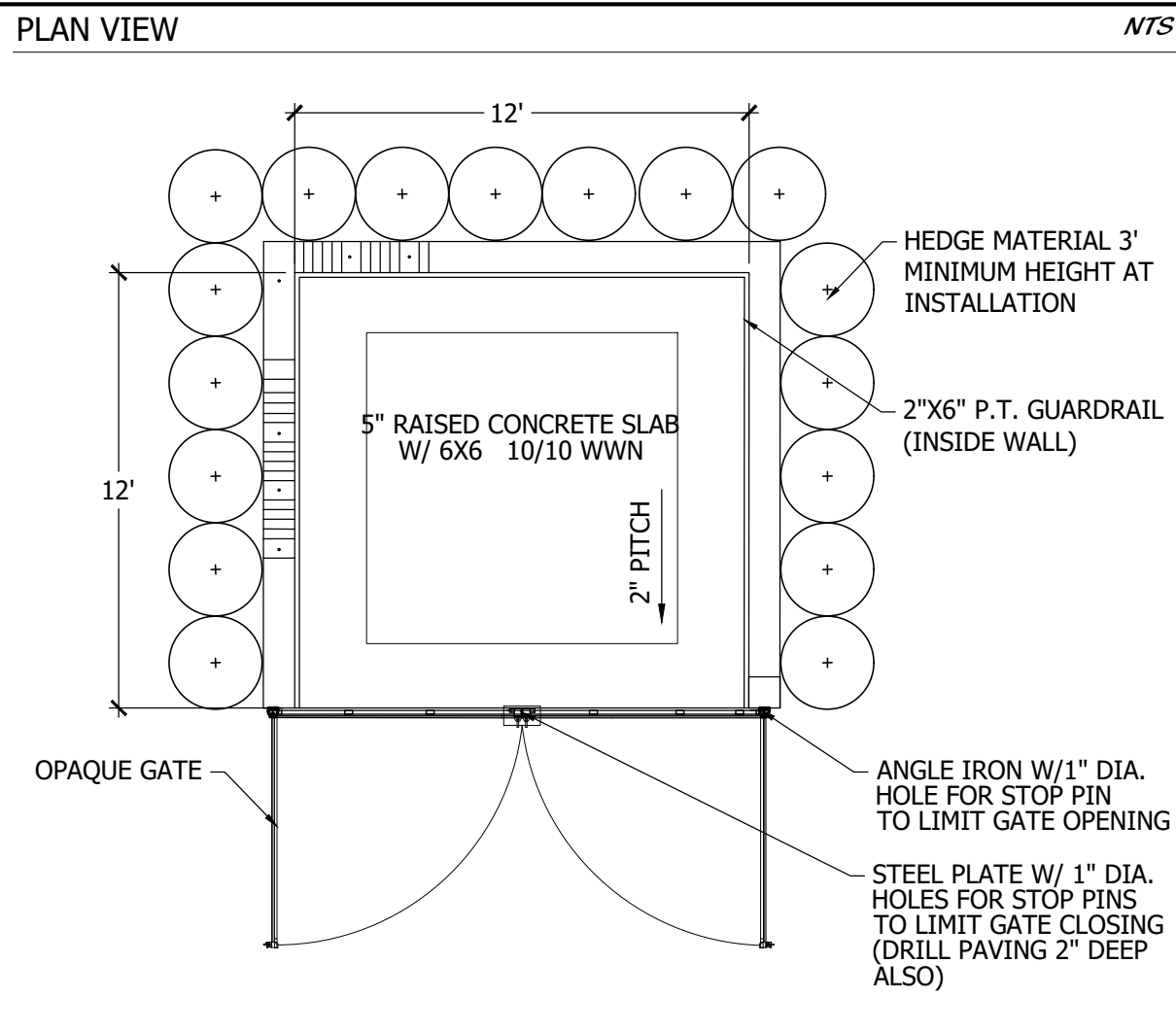
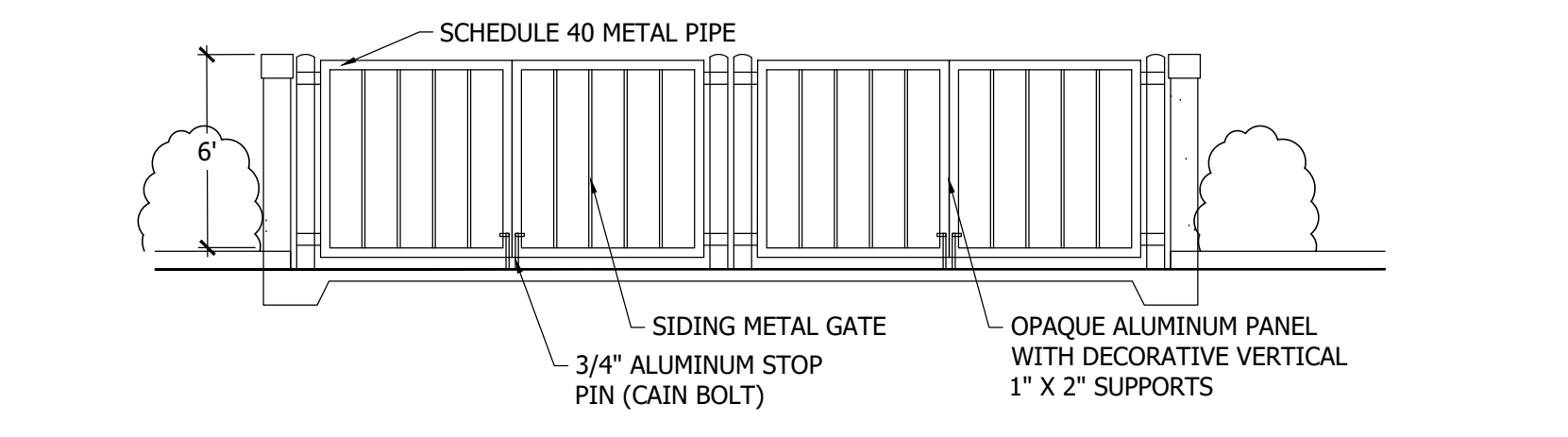

ELEVATION VIEW

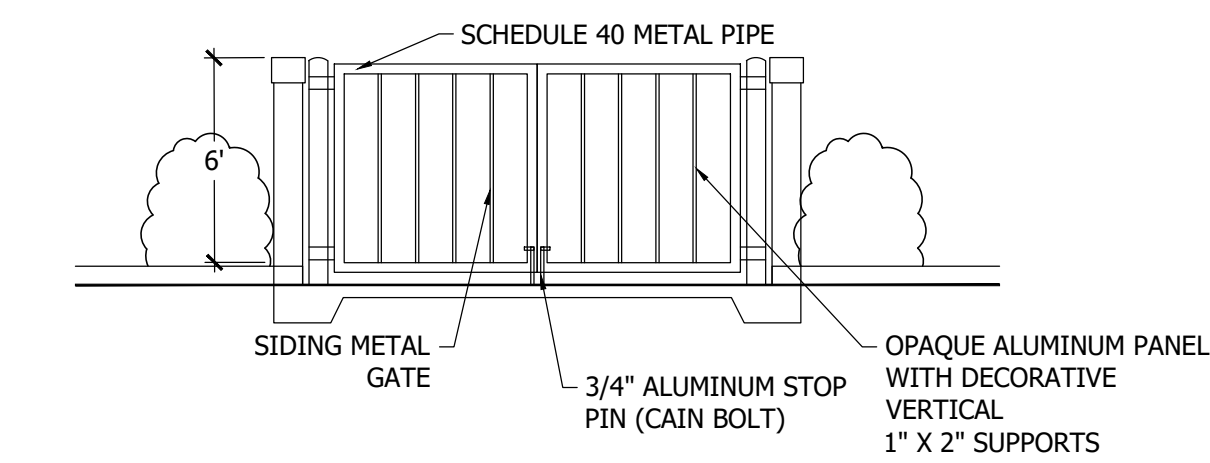

STANDARD AND ADA PARKING DETAIL

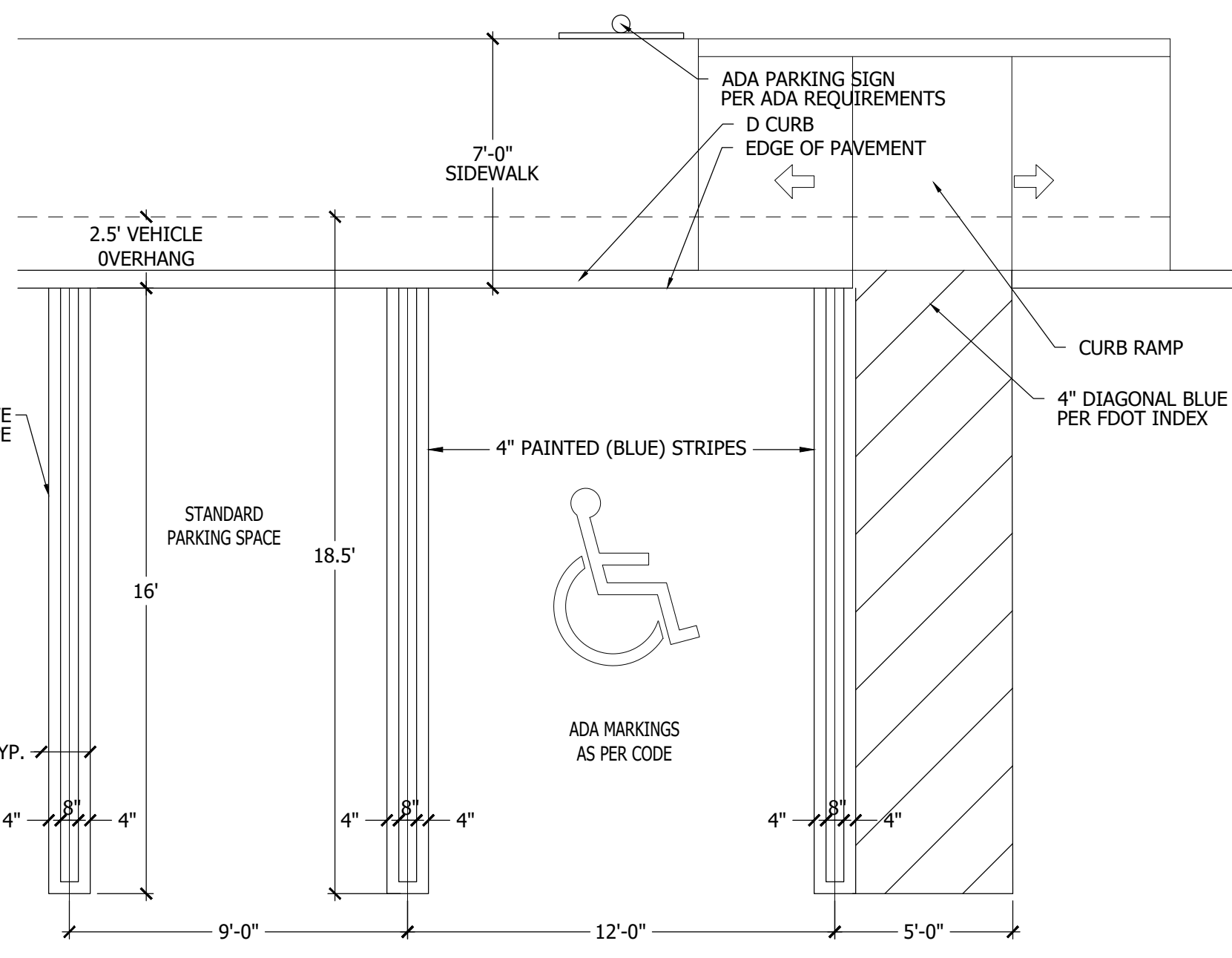

D CURB DETAIL

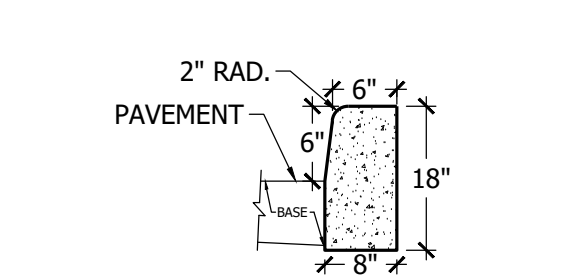

VALLEY CURB DETAIL

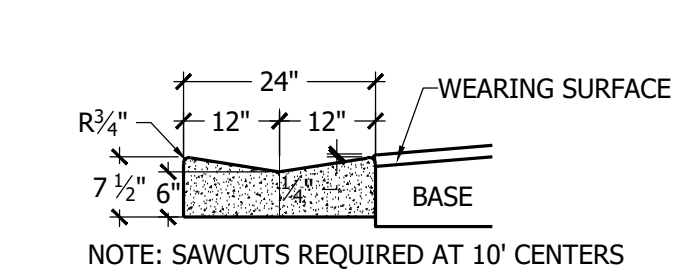

F CURB DETAIL

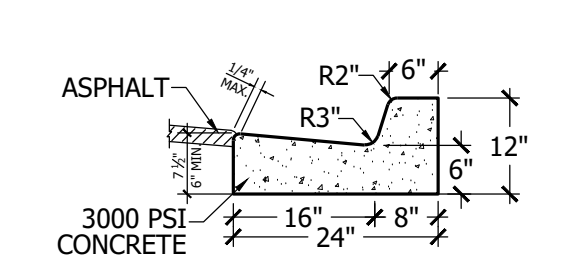

TRASH CAN DETAIL

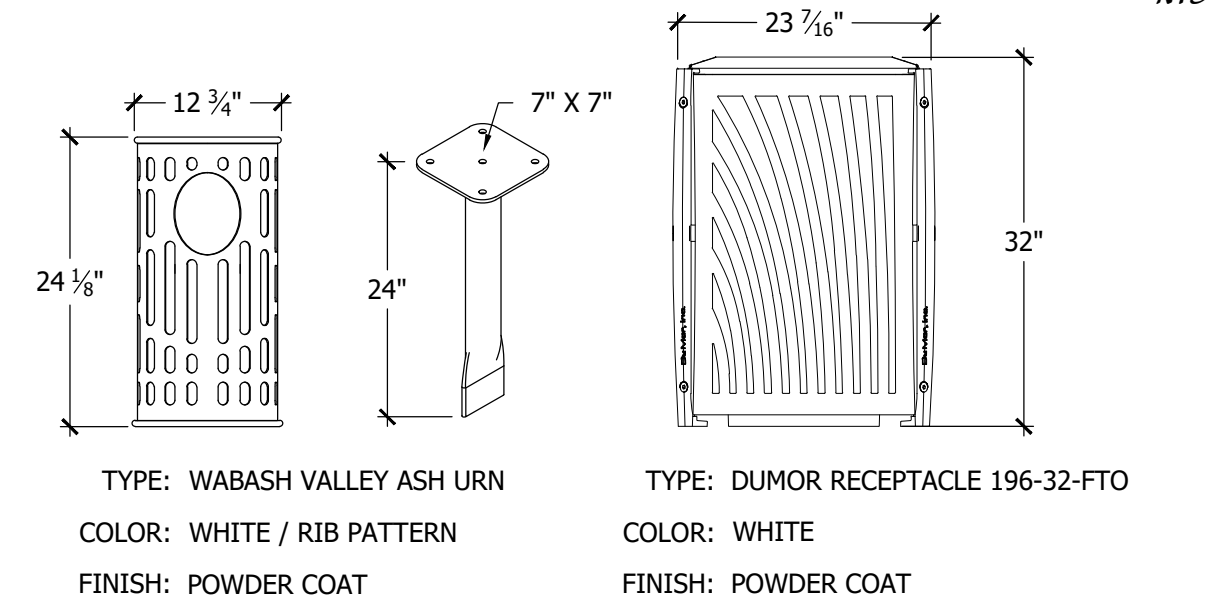

ADA RAMP DETAIL

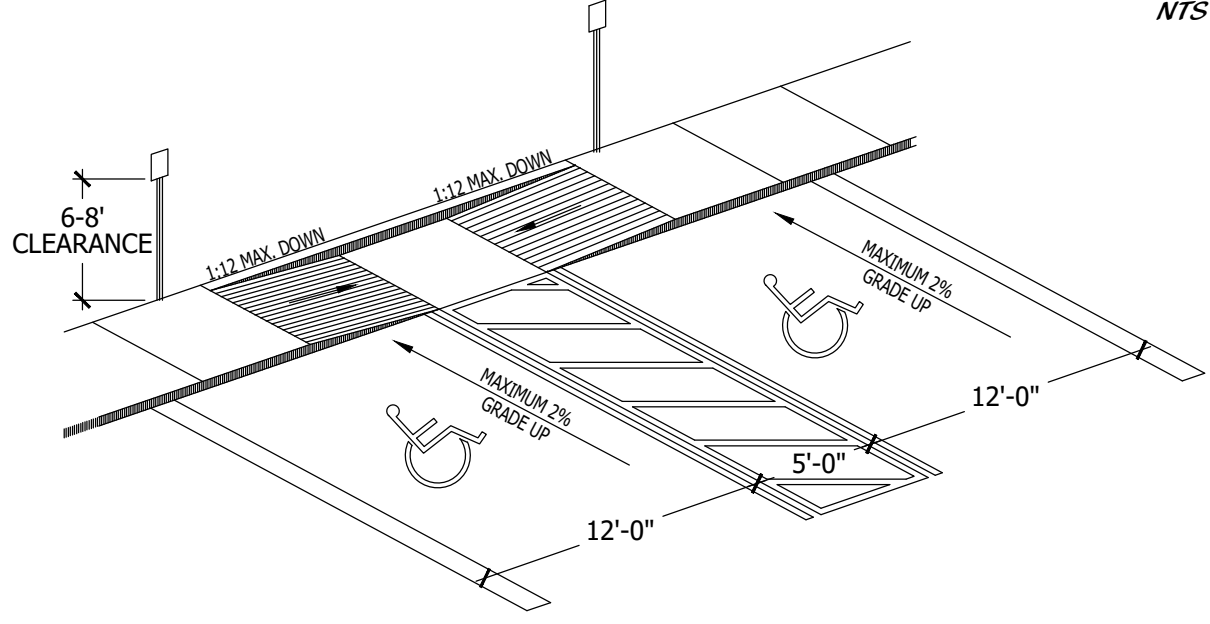

NOTE: IN THIS APPLICATION RAMP CAN BE SEPARATED AND SIDEWALK CAN BE FLUSH ACROSS ALL HC SPACES
NOTE: HCR#3-MOD MEANS ONLY 1 RAMP BUILT TO REQUIRED SIDE OF SIDEWALK. OR RAMP SEP. TO ENDS OF HC SPACES

ADA SIGN & SYMBOL DETAIL

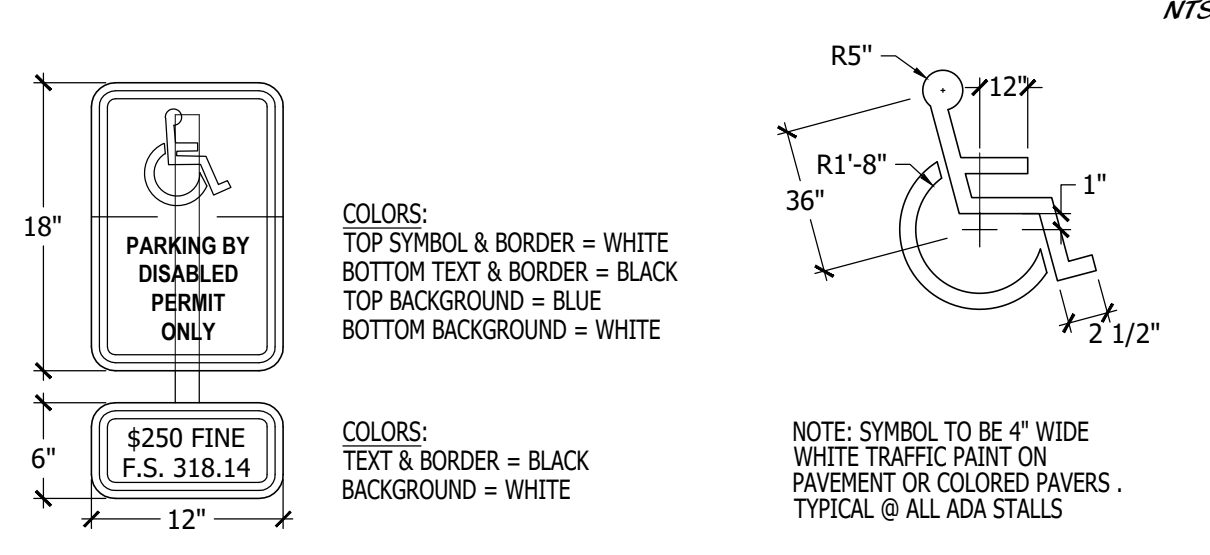

CROSS SECTIONS

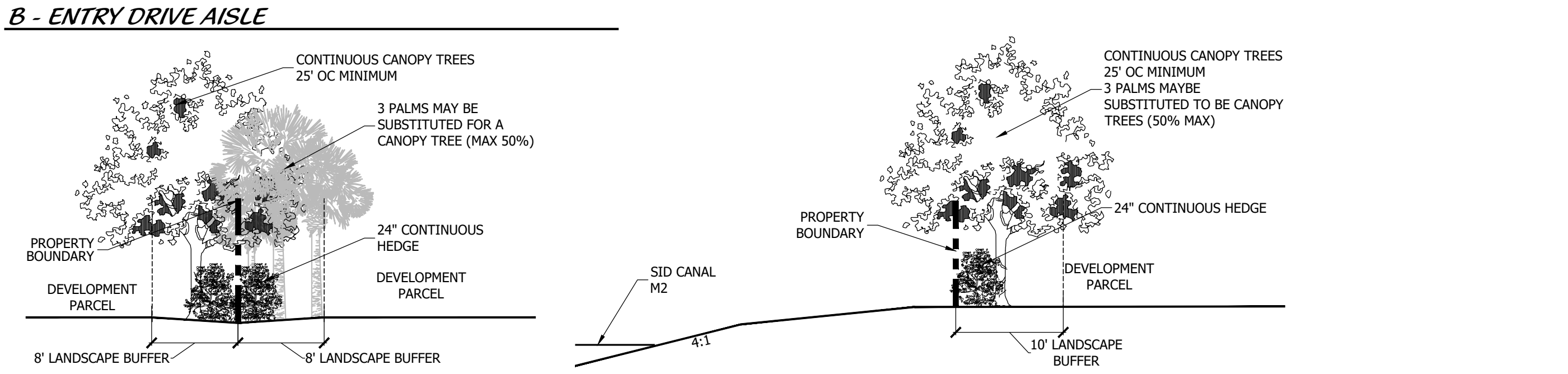
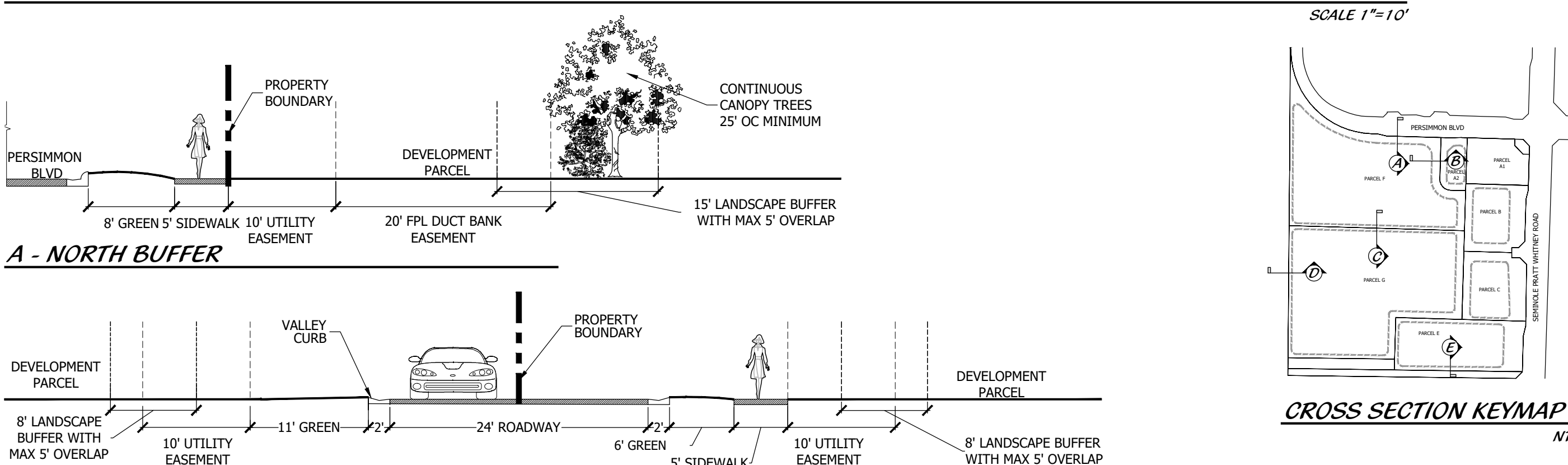

BENCH DETAILS

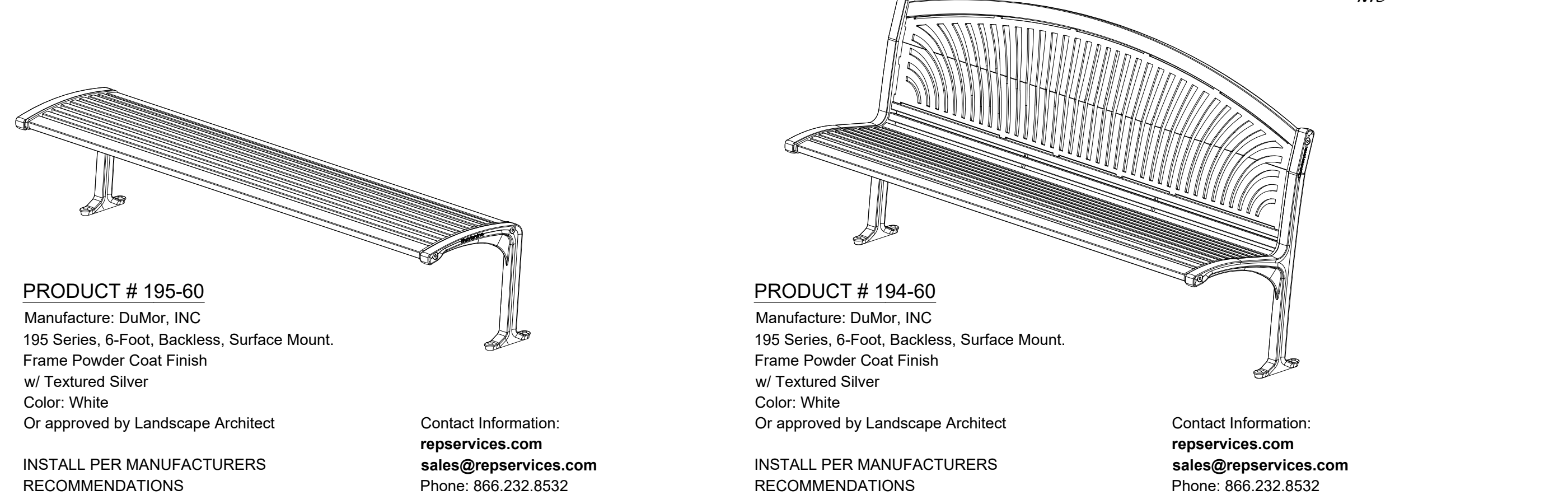

BIKE RACK DETAIL

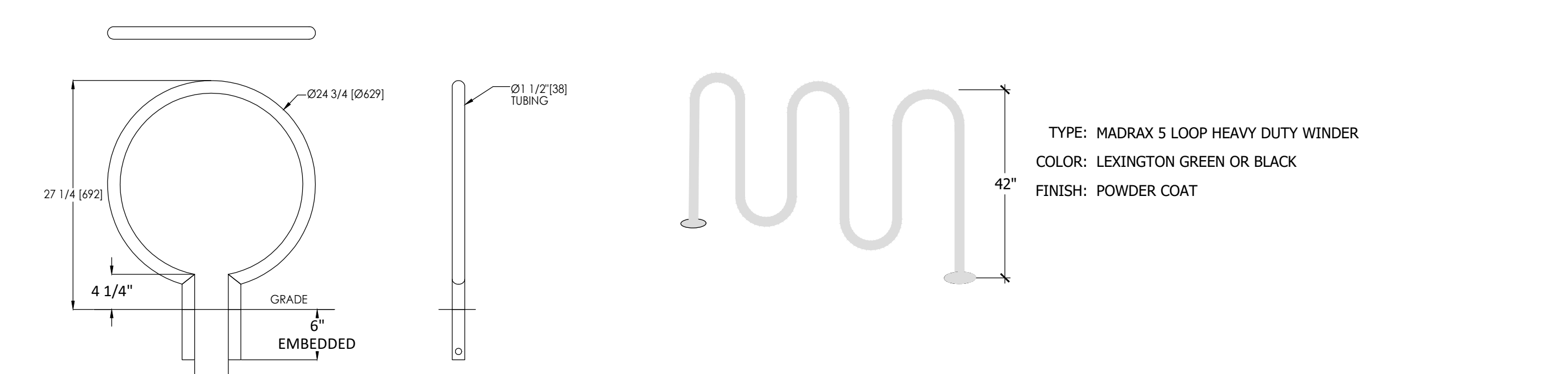

RING BIKE RACK, EMBEDDED (OR EQUAL) landscapeforms®
www.landscapeforms.com Ph: 800.521.2546

Site Details

Cotleur & Hearing
Landscape Architects
Land Planners
Environmental Consultants
1934 Commerce Lane
Suite 1
Jupiter, Florida 33458
561.747.6336 - Fax 747.1377
www.cotleurhearing.com
Lic# LC-C000239

WESTLAKE LANDINGS

POD H MASTER PLAN
PALM BEACH COUNTY, FL



DESIGNED	DEH
DRAWN	JAE/RNK
APPROVED	DEH
JOB NUMBER	13-0518.60
DATE	03-25-21
REVISIONS	04-12-21
	10-08-21 05-25-21
	11-03-21 06-12-21
	03-20-23 07-15-21
	01-03-23 09-03-21
	01-22-23 03-08-24 10-04-21