

ARPA SUBRECIPIENT AGREEMENT

Between
The CITY OF WESTLAKE, FLORIDA
And
SEMINOLE IMPROVEMENT DISTRICT
FOR AMERICAN RESCUE PLAN ACT (“ARPA”) FUNDS TO BE USED FOR STORMWATER
INFRASTRUCTURE

THIS AGREEMENT is made between the CITY OF WESTLAKE, FLORIDA (hereinafter “CITY”), and SEMINOLE IMPROVEMENT DISTRICT (hereinafter “SUBRECIPIENT”).

WHEREAS, on March 11, 2021, President Joseph R. Biden signed into law the American Rescue Plan Act of 2021 (hereinafter “ARPA”); and

WHEREAS, on May 10, 2021, the United States Department of the Treasury (hereinafter “US TREASURY”) published guidance regarding the allowable usage of the Coronavirus State and Local Fiscal Recovery Funds (hereinafter “SLFRF”) to be disseminated to local governments in accordance with the ARPA; and

WHEREAS, the CITY intends to allocate its funds to the SUBRECIPIENT for the construction of storm water infrastructure in accordance with all federal, state, and local guidelines regarding the usage of SLFRF funds; and

WHEREAS, under ARPA, the CITY may transfer funds to a special-purpose unit of local government for the purpose of meeting ARPA’s goals for the construction of storm water infrastructure; and

WHEREAS, during its City Council meeting on _____, the City Council (hereinafter “Council”) approved the request from the SUBRECIPIENT subject to all federal, state, and local guidelines regarding the usage of the funds, including any contractual guidelines set forth by the Council, as well as any audit requirements established by the Florida Auditor General’s Office; and

WHEREAS, the CITY and SUBRECIPIENT desire to enter into this Agreement.

NOW, THEREFORE, in consideration of the foregoing recitals which are incorporated herein by reference, and the terms and conditions set forth below, the parties agree as follows:

1. EFFECTIVE DATE AND TERM

This Agreement shall commence upon execution by all parties (“Commencement Date”) and remain in effect one (1) year subsequent to the Commencement Date, unless sooner terminated by the CITY in accordance with the terms herein.

2. GRAND TOTAL SLFRF FUNDS TO BE DISSEMINATED TO SUBRECIPIENT

The grand total award of ARPA funds to be disseminated by the CITY to the SUBRECIPIENT as part of this Agreement shall not exceed \$750,000.00.

3. LIMITATIONS REGARDING THE USE OF SLFRF FUNDS

The SUBRECIPIENT shall ensure that all expenditures utilizing SLFRF funds received in accordance with this Agreement shall be limited to only those eligible expenses as outlined under the guidelines of ARPA for the construction of storm water infrastructure and in accordance with all applicable law and the US TREASURY FAQs. Pursuant to 31 CFR §35.6, the SUBRECIPIENT may use funds to cover eligible costs incurred on behalf of the City to make the necessary improvements to the stormwater system and the master drainage system for the approximately 74-acre property located at the Northwest corner of Seminole Pratt Whitney Road and West Sycamore Street (“site”) in order to prepare the site for the development of a City park to serve the City residents (“Project”) in conformance with the attached Scope of Services, as set forth in Exhibit “A” attached hereto. Funds may not be used to pay interest or principal on other outstanding debt.

4. REPORTING REQUIREMENTS TO ENSURE COMPLIANCE WITH ARPA

In order to ensure compliance with the existing ARPA guidelines set forth by the US TREASURY while also ensuring that all expenditures within the scope of this Agreement adhere to future guidelines that may be established by the US TREASURY during the term of this Agreement, the SUBRECIPIENT, when requesting reimbursement for eligible ARPA expenditures, shall provide to the CITY a comprehensive and detailed list of all such expenditures on an itemized invoice, and shall also provide any backup documentation to support such expenditures. Said invoice must include a statement, signed by the SUBRECIPIENT, indicating that all expenditures therein comport with the guidelines of the ARPA as set forth by the US TREASURY. Reimbursement requests shall be submitted to the CITY no more than once per month. No reimbursement requests may be submitted to the CITY later 400 days subsequent to the Commencement Date. If any such future guidelines somehow prohibit SUBRECIPIENT’s intended use of funds, then the parties will use reasonable good faith efforts to make sure the funds are used in accordance with such guidelines.

5. TIMELINE REGARDING THE DISSEMINATION OF FUNDS TO SUBRECIPIENT

Upon receipt of the SUBRECIPIENT’s complete reimbursement request, the CITY shall disseminate funds for all eligible ARPA expenditures therein within twenty (20) calendar days of receipt of said reimbursement request. The dissemination of SLFRF funds shall only occur after the CITY reviews the SUBRECIPIENT’s reimbursement request to ensure that all expenditures detailed therein qualify for reimbursement in accordance with all published federal, state, and local guidance regarding the use of SLFRF funds as specified in the ARPA. CITY must notify SUBRECIPIENT within ten (10) days of if it does not approve the reimbursement request with directions how to cure (if any). All payments from the CITY to the SUBRECIPIENT are subject to all applicable federal, state, and local laws regarding the governance of CITY funds within the ARPA.

6. EVOLUTION OF ARPA GUIDANCE FROM THE US TREASURY

The CITY may request additional information from the SUBRECIPIENT, as needed, to meet any additional guidelines regarding the use of the funds that may be established by the US TREASURY

during the term of this Agreement.

7. TERMINATION

The CITY may terminate this Agreement, for convenience or otherwise and for no consideration or damages, upon prior notice to the SUBRECIPIENT. Termination of the Agreement will not affect funding that has already occurred.

8. INDEPENDENT CONTRACTOR

Each party under the Agreement shall be for all purposes an independent Contractor. Nothing contained herein will be deemed to create an association, a partnership, a joint venture, or a relationship of principal and agent, or employer and employee between the parties. The SUBRECIPIENT shall not be, or be deemed to be, or act or purport to act, as an employee, agent, or representative of the CITY for any purpose.

9. HOLD HARMLESS AND INDEMNIFICATION

The SUBRECIPIENT agrees to defend, indemnify, and hold the CITY, its officers, officials, employees, agents, and volunteers harmless from and against any and all third party claims, injuries, actual out of pocket damages, losses or expenses, including without limitation personal injury, bodily injury, sickness, disease, or death, or damage to or destruction of property, which are alleged or proven to be caused in whole or in part by an act or omission of the SUBRECIPIENT, its officers, directors, employees, and/or agents relating to the SUBRECIPIENT's performance or failure to perform under this Agreement, unless such claim, injury, damages, losses or expenses, resulted out of the CITY, its officers, officials, employees, agents, and volunteers own misconduct or negligence. The SUBRECIPIENT shall be entitled to prior notice and an opportunity to defend any indemnifiable third party claim. This section shall survive the expiration or termination of this Agreement.

10. COMPLIANCE WITH LAWS AND GUIDELINES

The SUBRECIPIENT shall at all times comply with all applicable federal, state, and local laws and all requirements and published guidance set forth regarding the usage of any and all monies appropriated under the ARPA. The SUBRECIPIENT agrees to execute any further documents necessary for this Agreement and the transfer of funds, as provided herein, to comply with any federal, state, and local laws or requirements under the ARPA.

11. MAINTENANCE AND AUDIT OF RECORDS

The SUBRECIPIENT shall maintain records, books, documents, and other materials relevant to its performance under this Agreement. These records shall be subject to inspection, review, and audit by the CITY or its designees, and the US TREASURY for seven (7) years following termination of this Agreement. If it is determined during the course of the audit that the SUBRECIPIENT was reimbursed for unallowable costs under this Agreement, the SUBRECIPIENT agrees to either promptly reimburse the CITY for such payments upon request or reallocate to funds to eligible costs as approved by City.

12. NOTICES

Any notices desired or required to be given hereunder shall be in writing, and shall be deemed received three (3) days after deposit with the US Postal Service (postage fully prepaid, certified mail, return receipt requested), and addressed to the party to which it is intended at its last known address, or to such person or address as either party shall designate to the other from time to time in writing forwarded in like manner:

SUBRECIPIENT Kenneth Cassel, District Manager
Seminole Improvement District
4001 Seminole Pratt Whitney Road
Westlake, Florida 33470
Telephone No. (561) 790-1742

Copy To: Robert Diffenderfer
Shareholder
Lewis, Longman & Walker, P.A.
360 South Rosemary Avenue, Suite 1100
West Palm Beach, Florida 33401
Email: rdiffenderfer@llw-law.com
Telephone No. 561.640.0820
Facsimile No. 561.640.8202

CITY Kenneth Cassel, City Manager
City of Westlake
4001 Seminole Pratt Whitney Road
Westlake, Florida 33470
Telephone No. (561) 790-1742

Copy To: Donald J. Doody, City Attorney
Goren, Cherof, Doody & Ezrol, P.A.
3099 East Commercial Boulevard, Suite 200
Fort Lauderdale, Florida 33308
Email: ddoody@gorencherof.com
Telephone No. (954) 771-4500
Facsimile No. (954) 771-4923

13. IMPROPER INFLUENCE

Each party warrants that it did not and will not employ, retain, or contract with any person or entity on a contingent compensation basis for the purpose of seeking, obtaining, maintaining, or extending this Agreement. Each party agrees, warrants, and represents that no gratuity whatsoever has been or will be offered or conferred with a view towards obtaining, maintaining, or extending this Agreement.

14. CONFLICT OF INTEREST

The elected and appointed officials and employees of the parties shall not have any personal interest, direct or indirect, which gives rise to a conflict of interest.

15. PUBLIC RECORDS

The CITY is a public agency subject to Chapter 119, Florida Statutes. SUBRECIPIENT shall comply with Florida's Public Records Law. Specifically, SUBRECIPIENT shall:

- A. Keep and maintain public records required by the CITY;
- B. Upon request from the CITY's custodian of public records, provide the CITY with a copy of the requested records or allow the records to be inspected or copied within a reasonable time at a cost that does not exceed the cost provided in Chapter 119, Florida Statutes, or as otherwise provided by law;
- C. Ensure that public records that are exempt or that are confidential and exempt from public records disclosure requirements are not disclosed except as authorized by law for the duration of the contract term and, following completion of the Agreement, SUBRECIPIENT shall destroy all copies of such confidential and exempt records remaining in its possession after SUBRECIPIENT transfers the records in its possession to the CITY; and
- D. Upon completion of the Agreement, SUBRECIPIENT shall transfer to the CITY, at no cost to the CITY, all public records in SUBRECIPIENT's possession. All records stored electronically by SUBRECIPIENT must be provided to the CITY, upon request from the CITY's custodian of public records, in a format that is compatible with the information technology systems of the CITY.

The failure of SUBRECIPIENT to comply with the provisions set forth in the Agreement shall constitute a Default and Breach of the Agreement, for which, the CITY may terminate the Agreement.

IF SUBRECIPIENT HAS QUESTIONS REGARDING THE APPLICATION OF CHAPTER 119, FLORIDA STATUTES, TO SUBRECIPIENT'S DUTY TO PROVIDE PUBLIC RECORDS RELATING TO THE AGREEMENT, CONTACT THE CUSTODIAN OF PUBLIC RECORDS AT:

**CITY CLERK
4001 SEMINOLE PRATT WHITNEY ROAD
WESTLAKE, FL 33470
(561) 790-1742
zburgess@westlakegov.com**

16. TIME

Time is of the essence in this Agreement.

17. SURVIVAL

The provisions of this Agreement that by their sense and purpose should survive expiration or termination of the Agreement shall so survive. Those provisions include without limitation Indemnification and Maintenance and Audit of Records.

18. AMENDMENT

No amendment or modification to the Agreement shall be effective without prior written consent of the authorized representatives of the parties.

19. GOVERNING LAW; VENUE

The Agreement shall be governed in all respects by the laws of the State of Florida, both as to interpretation and performance, without regard to conflicts of law or choice of law provisions. Any action arising out of or in conjunction with the Agreement may be instituted and maintained only in a court of competent jurisdiction in Palm Beach County, Florida.

20. NON-WAIVER

No failure on the part of the CITY to exercise, and no delay in exercising, any right hereunder shall operate as a waiver thereof, nor shall any single or partial exercise by the CITY of any right hereunder preclude any other or further exercise thereof or the exercise of any other right. The remedies herein provided are cumulative and not exclusive of any remedy available to the CITY at law or in equity.

21. BINDING EFFECT

This Agreement shall be binding upon and inure to the benefit of the parties hereto and their respective successors.

22. ASSIGNMENT

The SUBRECIPIENT shall not assign or transfer any of its interests in or obligations under this Agreement without the prior written consent of the CITY.

23. ENTIRE AGREEMENT

This Agreement constitutes the entire agreement between the CITY and the SUBRECIPIENT for the use of funds received under this Agreement and it supersedes all prior or contemporaneous communications and proposals, whether electronic, oral, or written between the parties with respect to this Agreement.

24. NO THIRD-PARTY BENEFICIARIES

Nothing herein shall or be deemed to create or confer any right, action, or benefit in, to, or on the part of any person or entity that is not a party to this Agreement. This provision shall not limit any obligation which either party has to the US TREASURY in connection with the use of ARPA funds, including the obligations to provide access to records and cooperate with audits as provided in this Agreement.

25. CIVIL RIGHTS COMPLIANCE

SubRecipients of Federal financial assistance from the US TREASURY are required to meet legal requirements relating to nondiscrimination and nondiscriminatory use of Federal funds. Those requirements include ensuring that entities receiving Federal financial assistance from the US TREASURY do not deny benefits or services, or otherwise discriminate on the basis of race, color, national origin (including limited English proficiency), disability, age, or sex (including sexual orientation and gender identity), in accordance with the following authorities: Title VI of the Civil Rights Act of 1964 (Title VI) Public Law 88-352, 42 U.S.C. 2000d-1 et seq., and the Department's implementing regulations, 31 CFR part 22; Section 504 of the Rehabilitation Act of 1973 (Section

504), Public Law 93-112, as amended by Public Law 93-516, 29 U.S.C. 794; Title IX of the Education Amendments of 1972 (Title IX), 20 U.S.C. 1681 et seq., and the Department's implementing regulations, 31 CFR part 28 [Title IX of the Education Amendments is not applicable]; Age Discrimination Act of 1975, Public Law 94-135, 42 U.S.C. 6101 et seq., and the Department implementing regulations at 31 CFR part 23.

26. SEVERABILITY

In the event that one or more provisions of this Agreement shall be determined to be invalid by any court of competent jurisdiction or agency having jurisdiction thereof, the remainder of the Agreement shall remain in full force and effect and the invalid provisions shall be deemed deleted.

27. COUNTERPARTS

This Agreement may be executed in on or more counterparts, any of which shall be deemed an original, but all of which together shall constitute one and the same instrument.

28. AUTHORIZATION

Each party signing below warrants to the other party, that they have the full power and authority to execute this Agreement on behalf of the party for whom they sign.

IN WITNESS WHEREOF, this Agreement is executed and shall become effective as of the last date signed below:

Dated this _____ day of _____, 2023.

SUBRECIPIENT:
SEMINOLE IMPROVEMENT DISTRICT

CITY:
CITY OF WESTLAKE

Scott Massey, President

John Paul O'Connor, Mayor

APPROVED AS TO FORM:

Office of the City Attorney

ATTEST:

City Clerk

EXHIBIT A
PLANS / SCOPE OF SERVICES

SEMINOLE IMPROVEMENT DISTRICT

Park Parcel C-4 Drainage Modifications

Westlake, Florida

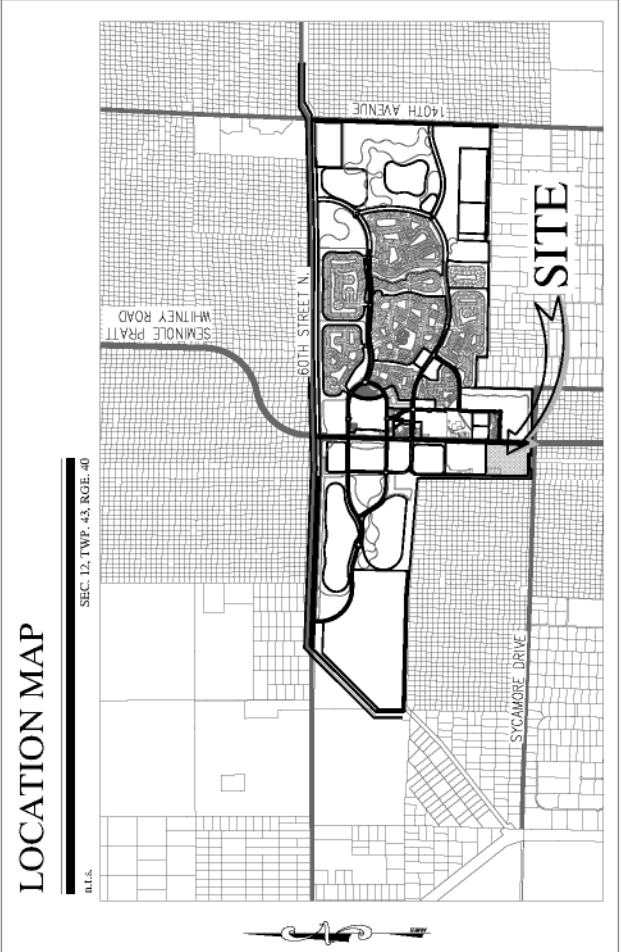

INDEX

- 01 Cover Page
- 02 - 03 Paving, Grading, & Drainage Plans
- 04 - 05 Paving, Grading, & Drainage Details
- 06 Pollution Prevention Plan

REVISIONS	DATE	BY

CAULFIELD & WHEELER, INC.
 CIVIL ENGINEERING - LAND PLANNING
 LANDSCAPE ARCHITECTURE - SURVEYING
 7000 GLENDS ROAD - SUITE 100
 ROCK HOLLOW, FLORIDA 33444
 PHONE (561) 342-1401 / FAX (561) 750-1452

SEMINOLE IMPROVEMENT DISTRICT /
 WESTLAKE PARK PARCEL C-4
 COVER SHEET
 WESTLAKE, FLORIDA

DATE 09/06/2023
DRAWN BY RHL
P.E.B./P.C. 0000
SCALE N/A

RYAN D. WHEELER
 PROFESSIONAL ENGINEER
 LICENSE NO. 12400
 STATE OF FLORIDA
 100 THE RIVER
 WESTLAKE, FLA 33080

JOB # 6500
SHEET
01
OF 06 SHEETS

DATE	12/12/2024
BY	
REVISIONS	
DATE	12/12/2024
BY	
REVISIONS	
DATE	12/12/2024
BY	
REVISIONS	

CAULFIELD & WHEELER, INC.
 CIVIL ENGINEERING - LAND PLANNING
 LANDSCAPE ARCHITECTURE - SURVEYING
 7000 GLADES ROAD - SUITE 100
 MIAMI, FLORIDA 33154
 PHONE (305) 392-4001 / FAX (305) 750-1152

SEMINOLE IMPROVEMENT DISTRICT /
 WESTLAKE PARK PARCEL C-4 /
 DRAINAGE IMPROVEMENTS
 WESTLAKE, FLORIDA

DATE 09/06/2023
 DRAWN BY RHT
 P.B./P.C. N/A
 SCALE 1"=50'

RYAN D. WHEELER
 PROFESSIONAL ENGINEER
 STATE OF FLORIDA
 LICENSE NO. 22825

JOB # 8500
 SHEET NO. 02
 OF 08 SHEETS

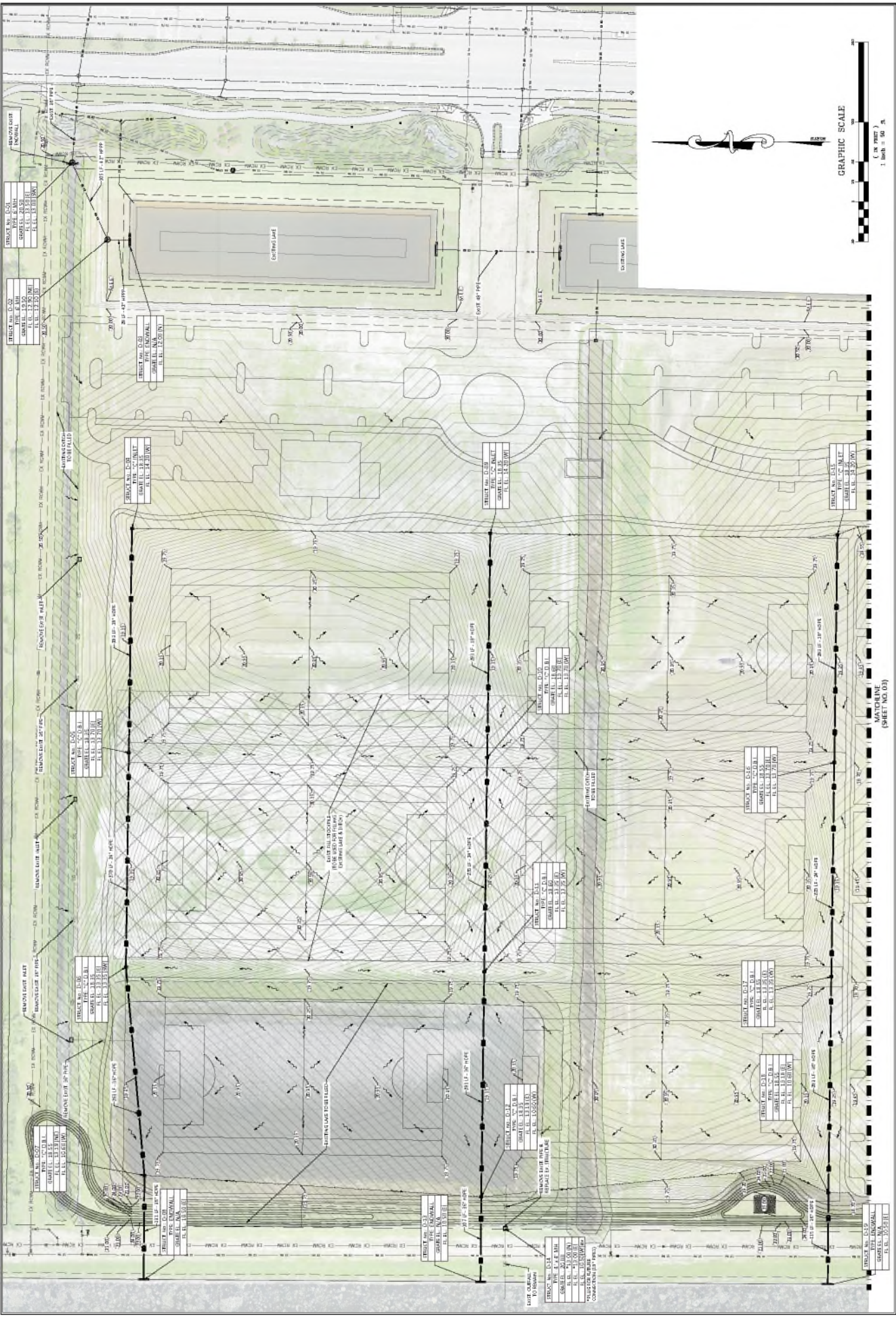

MATCHLINE
 (SHEET NO. 03)

DATE	01/17/2024
BY	
REV	
DESCRIPTION	
DATE	01/17/2024
BY	
REV	
DESCRIPTION	

CAULFIELD & WHEELER, INC.
 CIVIL ENGINEERING - LAND PLANNING
 LANDSCAPE ARCHITECTURE - SURVEYING
 7000 GLADES ROAD - SUITE 100
 MIAMI, FLORIDA 33154
 PHONE (305) 321-1001 / FAX (305) 750-1152

SEMINOLE IMPROVEMENT DISTRICT / WESTLAKE PARK PARCEL C-4
 DRAINAGE IMPROVEMENTS
 WESTLAKE, FLORIDA

DATE 09/06/2023
 DRAWN BY RHL
 P.E./P.L. N/A
 SCALE 1"=50'

RYAN D. WHEELER
 PROFESSIONAL ENGINEER
 STATE OF FLORIDA
 LICENSE NO. 22825

JOB # 6500
 SHEETS
03
 OF 06 SHEETS

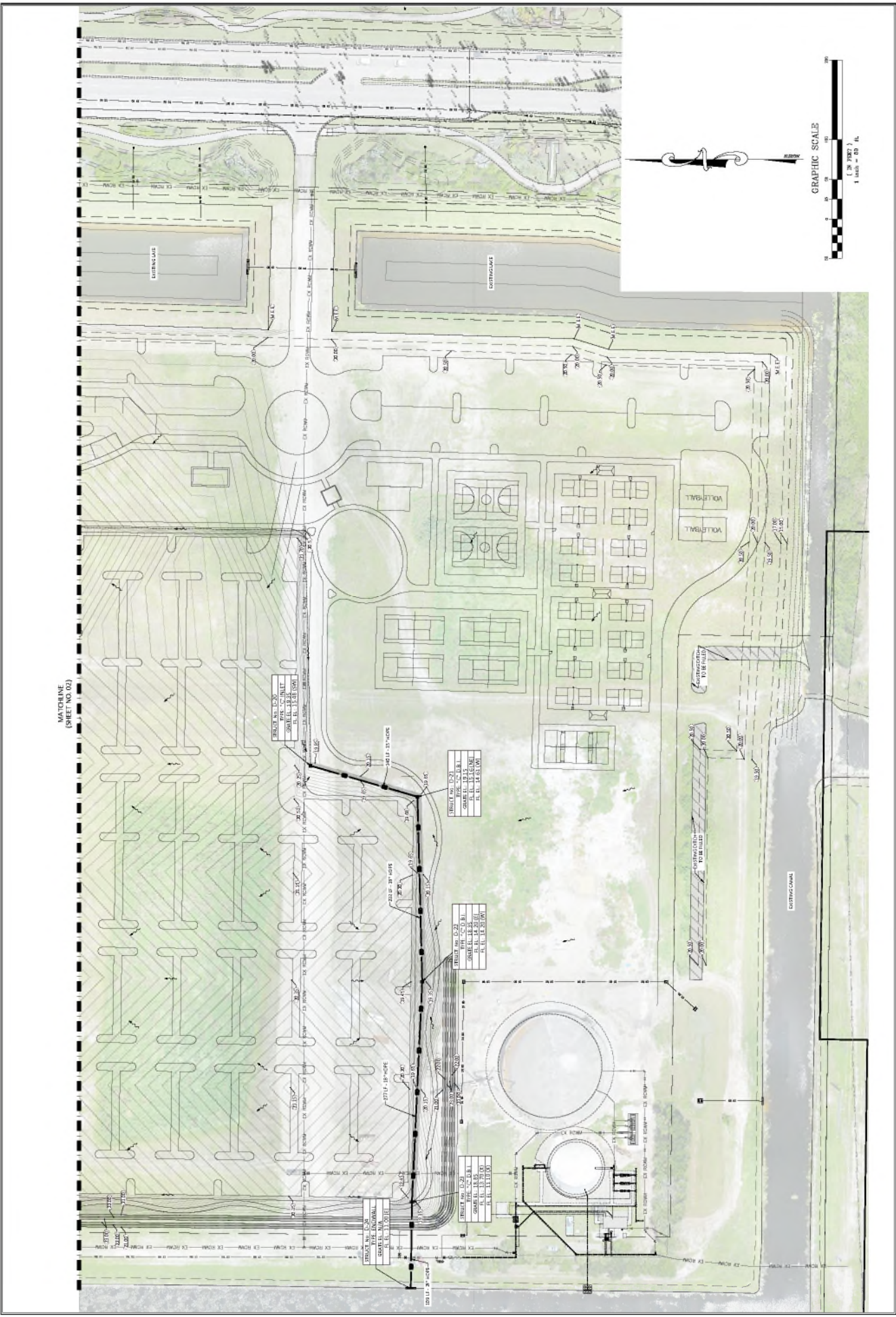

REVISIONS	DATE	BY

CAULFIELD & WHEELER, INC.
 7000 GLENDALE ROAD - SUITE 100
 ROCK HILL, SOUTH CAROLINA 29730
 PHONE (803) 324-4901 / FAX (803) 324-4922

SEMINOLE IMPROVEMENT DISTRICT /
 WESTLAKE PARK PARCEL C-4 /
 PAVING, GRADING, & DRAINAGE DETAILS
 WESTLAKE FLOORPLAN

DATE: 09/06/2023
 DRAWN BY: RHT
 P.E./P.C.: N/A
 SCALE: N/A

RYAN D. WHEELER
 PROFESSIONAL ENGINEER
 STATE OF FLORIDA
 LICENSE NO. 22825

JOB # 8500
 SHEET NO. 03
 OF 08 SHEETS

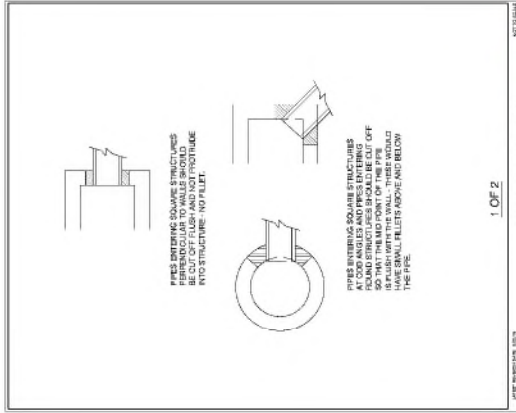

STRUCTURE PIPE
 GROUTING DETAIL
 (1 of 2)

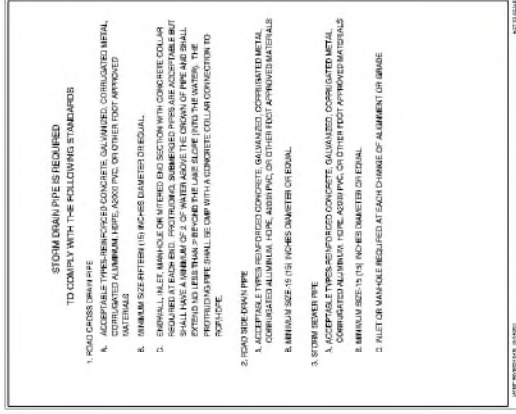

STORM DRAIN
 PIPE MATERIALS

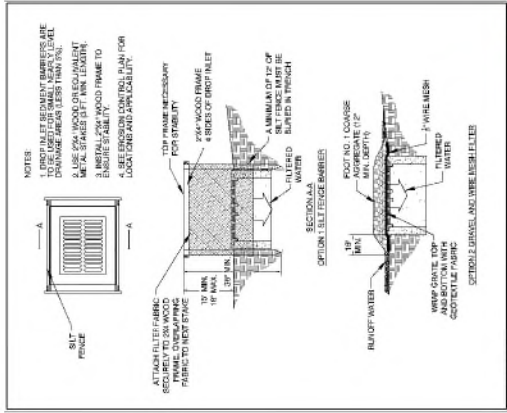
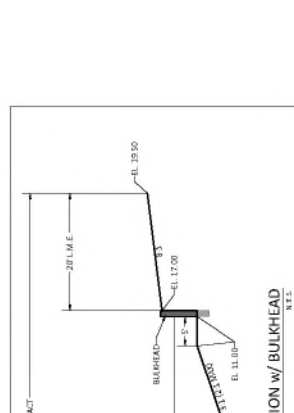
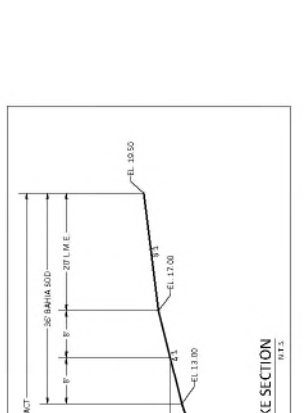

DROP INLET SEDIMENT
 FILTER DETAIL

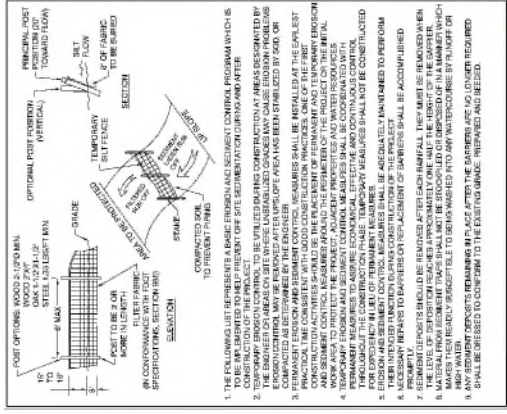

SILT FENCE AND EROSION
 CONTROL DETAIL

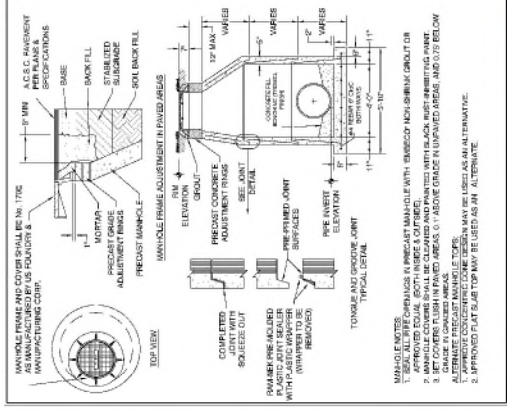

STORM SEWER MANHOLE
 DETAIL

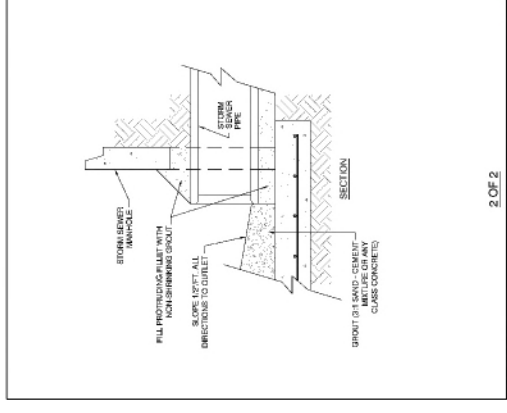

STRUCTURE PIPE
 GROUTING DETAIL
 (2 of 2)

