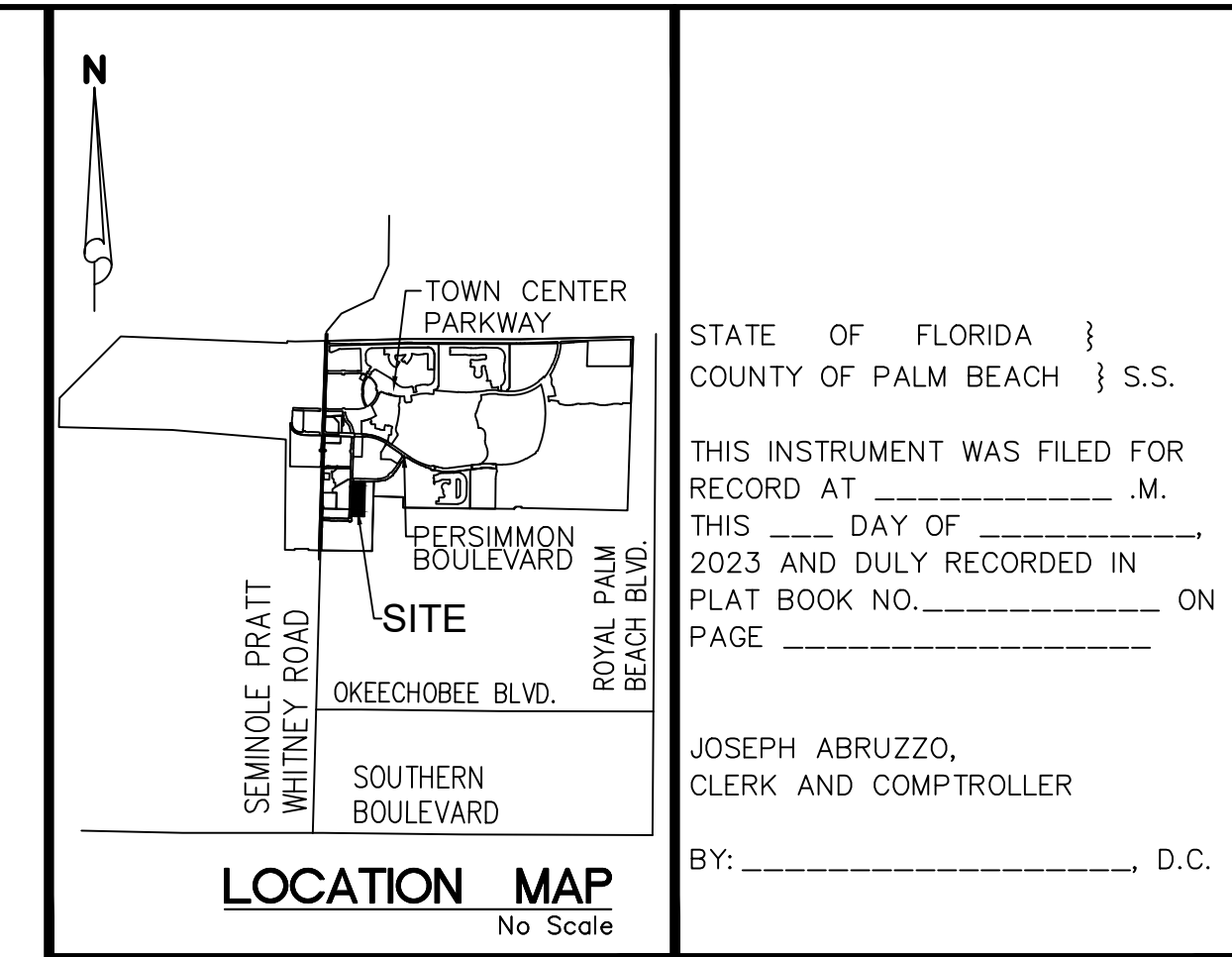

Exhibit 'B'
TERRACES OF WESTLAKE – PHASE I
PLAT

THIS PAGE WAS LEFT BLANK ON PURPOSE

TERRACES OF WESTLAKE - PHASE I

BEING A REPLAT OF A PORTION OF TRACT "A", WESTLAKE POD I AND POD J, PLAT BOOK 130, PAGES 153 AND 154, PUBLIC RECORDS OF PALM BEACH COUNTY, FLORIDA, LYING IN SECTION 12, TOWNSHIP 43 SOUTH, RANGE 40 EAST, CITY OF WESTLAKE, PALM BEACH COUNTY, FLORIDA.



DESCRIPTION:

KNOW ALL MEN BY THESE PRESENTS THAT MINTO PBLH, LLC, A FLORIDA LIMITED LIABILITY COMPANY, OWNER OF THE LAND SHOWN AND DESCRIBED HEREON AS TERRACES OF WESTLAKE - PHASE I, BEING A REPLAT OF A PORTION OF TRACT "A", WESTLAKE POD I AND POD J, PLAT BOOK 130, PAGES 153 AND 154, PUBLIC RECORDS OF PALM BEACH COUNTY, FLORIDA, LYING IN SECTION 12, TOWNSHIP 43 SOUTH, RANGE 40 EAST, CITY OF WESTLAKE, PALM BEACH COUNTY, FLORIDA, BEING MORE PARTICULARLY DESCRIBED AS FOLLOWS:

COMMENCE AT THE NORTHEAST CORNER OF SECTION 1, TOWNSHIP 43 SOUTH, RANGE 40 EAST; THENCE S.89°51'16"W., ALONG THE NORTH LINE OF SAID SECTION 1, TOWNSHIP 43 SOUTH, RANGE 40 EAST, A DISTANCE OF 2025.30 FEET; THENCE S.00°08'44"E., DEPARTING SAID NORTH LINE OF SECTION 1, A DISTANCE OF 6919.41 FEET TO THE NORTHEAST CORNER OF TRACT "A", WESTLAKE POD I AND POD J, AS RECORDED IN PLAT BOOK 130, PAGES 153 AND 154, PUBLIC RECORDS OF PALM BEACH COUNTY, FLORIDA, SAID CORNER BEING THE **POINT OF BEGINNING**; THENCE S.01°22'47"W., ALONG THE EAST LINE OF SAID TRACT "A", A DISTANCE OF 1655.39 FEET; THENCE N.88°37'13"W., A DISTANCE OF 618.87 FEET TO A POINT ON THE WESTERLY LINE OF SAID TRACT "A" AND A POINT ON THE ADDITIONAL EASTERLY RIGHT-OF-WAY OF ILEX WAY, AS RECORDED IN OFFICIAL RECORDS BOOK 32120, PAGE 776, OF SAID PUBLIC RECORDS; THENCE BY THE FOLLOWING SIXTEEN (16) COURSES, BEING ALONG SAID WESTERLY LINE OF TRACT "A" AND ADDITIONAL EASTERLY RIGHT-OF-WAY OF ILEX WAY: 1) N.01°42'29"E., A DISTANCE OF 23.64 FEET; 2) THENCE N.14°55'59"E., A DISTANCE OF 38.42 FEET TO A NON-TANGENT INTERSECTION WITH A CURVE CONCAVE TO THE WEST, WITH A RADIUS OF 5045.00 AND A RADIAL BEARING OF N.88°48'57"W., AT SAID INTERSECTION; 3) THENCE NORTHERLY, ALONG THE ARC OF SAID CURVE THROUGH A CENTRAL ANGLE OF 00°35'56", A DISTANCE OF 52.73 FEET TO A POINT OF REVERSE CURVATURE OF A CURVE CONCAVE TO THE EAST, WITH A RADIUS OF 4955.00 FEET; 4) THENCE NORTHERLY, ALONG THE ARC OF SAID CURVE, THROUGH A CENTRAL ANGLE OF 01°07'28", A DISTANCE OF 97.24 FEET TO A NON-TANGENT INTERSECTION; 5) THENCE N.01°42'52"E., A DISTANCE OF 173.57 FEET; 6) THENCE N.43°31'06"W., A DISTANCE OF 15.63 FEET; 7) THENCE N.01°42'52"E., A DISTANCE OF 118.28 FEET; 8) THENCE N.14°07'01"E., A DISTANCE OF 51.35 FEET; 9) THENCE N.01°42'52"E., A DISTANCE OF 409.91 FEET; 10) THENCE N.49°04'08"W., A DISTANCE OF 14.24 FEET; 11) THENCE N.01°42'52"E., A DISTANCE OF 327.18 FEET; 12) THENCE N.14°56'34"E., A DISTANCE OF 51.08 FEET TO A NON-TANGENT INTERSECTION WITH A CURVE CONCAVE TO THE SOUTHEAST, WITH A RADIUS OF 1149.00 AND A RADIAL BEARING OF S.86°18'08"E., AT SAID INTERSECTION; 13) THENCE NORTHERLY, ALONG THE ARC OF SAID CURVE THROUGH A CENTRAL ANGLE OF 01°08'29", A DISTANCE OF 22.89 FEET TO A POINT OF REVERSE CURVATURE OF A CURVE CONCAVE TO THE NORTHWEST, WITH A RADIUS OF 1251.00 FEET; 14) THENCE NORTHERLY, ALONG THE ARC OF SAID CURVE, THROUGH A CENTRAL ANGLE OF 03°07'28", A DISTANCE OF 68.22 FEET TO A POINT OF TANGENCY; 15) THENCE N.01°42'52"E., A DISTANCE OF 190.94 FEET; 16) THENCE N.46°42'52"E., A DISTANCE OF 3.02 FEET TO A POINT ON THE EASTERLY LINE OF ILEX WAY, AS SHOWN ON ILEX WAY - PHASE II, RECORDED IN PLAT BOOK 128, PAGES 22 THROUGH 25, INCLUSIVE, OF SAID PUBLIC RECORDS; THENCE S.88°17'08"E., ALONG SAID EASTERLY LINE OF ILEX WAY, A DISTANCE OF 14.14 FEET; THENCE N.46°42'52"E., ALONG SAID EASTERLY LINE OF ILEX WAY, A DISTANCE OF 16.97 FEET TO A POINT ON THE NORTH LINE OF SAID TRACT "A" AND A POINT ON THE SOUTHERLY RIGHT-OF-WAY LINE OF GREEN LANE, AS RECORDED IN PLAT BOOK 133, PAGES 83 THROUGH 87, INCLUSIVE, OF SAID PUBLIC RECORDS; THENCE S.88°17'08"E., ALONG SAID NORTH LINE OF TRACT "A" AND SAID SOUTHERLY RIGHT-OF-WAY LINE OF GREEN LANE A DISTANCE OF 348.87 FEET TO A POINT OF CURVATURE OF A CURVE CONCAVE TO THE NORTH, WITH A RADIUS OF 8050.00 FEET; THENCE EASTERLY, ALONG SAID NORTH LINE OF TRACT "A" AND SAID SOUTHERLY RIGHT-OF-WAY LINE OF GREEN LANE, AND ALONG THE ARC OF SAID CURVE THROUGH A CENTRAL ANGLE OF 01°29'36", A DISTANCE OF 209.81 FEET TO A POINT OF TANGENCY; THENCE S.89°46'44"E., A DISTANCE OF 11.73 FEET TO THE **POINT OF BEGINNING**.

CONTAINING: 1,008,827 SQUARE FEET OR 23.159 ACRES, MORE OR LESS.

HAS CAUSED THE SAME TO BE SURVEYED AND PLATTED AS SHOWN HEREON AND DO HEREBY DEDICATE AND RESERVE AS FOLLOWS:

ROAD RIGHT-OF-WAY

TRACT "A", SHOWN HEREON AS BANCROFT GARDENS LANE, BUTCHART LANE, GRAND TERRACE ISLE AND LONGWOOD LAKE SQUARE, ARE HEREBY DEDICATED TO TERRACES OF WESTLAKE HOMEOWNERS ASSOCIATION, INC., ITS SUCCESSORS AND ASSIGNS, IN FEE SIMPLE, AS A PRIVATE ROADWAY FOR INGRESS AND EGRESS, ACCESS, UTILITIES AND DRAINAGE PURPOSES, AND SHALL BE THE PERPETUAL MAINTENANCE OBLIGATION OF SAID ASSOCIATION. AN EASEMENT OVER AND UNDER SAID TRACT "A" AS SHOWN HEREON IS ALSO DEDICATED TO THE SEMINOLE IMPROVEMENT DISTRICT, AN INDEPENDENT SPECIAL DISTRICT OF THE STATE OF FLORIDA, ITS SUCCESSORS AND ASSIGNS, FOR ACCESS TO, AND FOR THE INSTALLATION AND MAINTENANCE OF, PUBLIC UTILITY FACILITIES, INCLUDING BUT NOT LIMITED TO STORMWATER, WATER, REUSE WATER AND WASTEWATER LINES AND APPURTENANT FACILITIES AND THE INSPECTION, REPAIR, REPLACEMENT, UPGRADE AND MAINTENANCE OF WATER, REUSE WATER, WASTEWATER, AND WATER MANAGEMENT FACILITIES. THE SEMINOLE IMPROVEMENT DISTRICT SHALL HAVE THE RIGHT TO GRANT OTHER UTILITY PROVIDERS THE ABILITY TO USE THE EASEMENT, IN ITS SOLE DISCRETION. AN EASEMENT OVER AND UNDER SAID TRACT "A" AS SHOWN HEREON IS ALSO RESERVED IN FAVOR OF THE CITY OF WESTLAKE FOR SERVICE VEHICLES AND EMERGENCY VEHICLES. THE CITY OF WESTLAKE AND THE SEMINOLE IMPROVEMENT DISTRICT SHALL NOT BE RESPONSIBLE FOR ANY MAINTENANCE OBLIGATIONS FOR SAID EASEMENT AREA OR SAID TRACT "A" EXCEPT AS SHALL RELATE TO THE SERVICING OF SUCH PUBLIC UTILITIES BY THE SEMINOLE IMPROVEMENT DISTRICT, AND FOR MAINTENANCE AS IT RELATES TO THE CITY OF WESTLAKE'S SERVICE VEHICLES AND EMERGENCY VEHICLES.

PRIVATE ROADS

TRACTS "B-1" THROUGH "B-3" SHOWN HEREON, ARE HEREBY DEDICATED TO TERRACES OF WESTLAKE HOMEOWNERS ASSOCIATION, INC., ITS SUCCESSORS AND ASSIGNS, IN FEE SIMPLE, AS A PRIVATE ROADS FOR THE PRIVATE INGRESS AND EGRESS OF THE ADJOINING LOT OWNERS OF SAID TRACTS, ACCESS, UTILITIES AND DRAINAGE PURPOSES, AND SHALL BE THE PERPETUAL MAINTENANCE OBLIGATION OF SAID ASSOCIATION. AN EASEMENT OVER AND UNDER SAID TRACTS AS SHOWN HEREON IS ALSO DEDICATED TO THE SEMINOLE IMPROVEMENT DISTRICT, AN INDEPENDENT SPECIAL DISTRICT OF THE STATE OF FLORIDA, ITS SUCCESSORS AND ASSIGNS, FOR ACCESS TO, AND FOR THE INSTALLATION AND MAINTENANCE OF, PUBLIC UTILITY FACILITIES, INCLUDING BUT NOT LIMITED TO STORMWATER, WATER, REUSE WATER AND WASTEWATER LINES AND APPURTENANT FACILITIES AND THE INSPECTION, REPAIR, REPLACEMENT, UPGRADE AND MAINTENANCE OF WATER, REUSE WATER, WASTEWATER, AND WATER MANAGEMENT FACILITIES. THE SEMINOLE IMPROVEMENT DISTRICT SHALL HAVE THE RIGHT TO GRANT OTHER UTILITY PROVIDERS THE ABILITY TO USE THE EASEMENT, IN ITS SOLE DISCRETION. AN EASEMENT OVER AND UNDER SAID TRACTS AS SHOWN HEREON IS ALSO RESERVED IN FAVOR OF THE CITY OF WESTLAKE FOR SERVICE VEHICLES AND EMERGENCY VEHICLES. THE CITY OF WESTLAKE AND THE SEMINOLE IMPROVEMENT DISTRICT SHALL NOT BE RESPONSIBLE FOR ANY MAINTENANCE OBLIGATIONS FOR SAID EASEMENT AREA OR SAID TRACTS EXCEPT AS SHALL RELATE TO THE SERVICING OF SUCH PUBLIC UTILITIES BY THE SEMINOLE IMPROVEMENT DISTRICT, AND FOR MAINTENANCE AS IT RELATES TO THE CITY OF WESTLAKE'S SERVICE VEHICLES AND EMERGENCY VEHICLES.

OPEN SPACE TRACTS

TRACTS O.S.T. #1 THROUGH O.S.T. #5, AS SHOWN HEREON, ARE HEREBY DEDICATED TO TERRACES OF WESTLAKE HOMEOWNERS ASSOCIATION, INC., ITS SUCCESSORS AND ASSIGNS, IN FEE SIMPLE, FOR OPEN SPACE PURPOSES AND SHALL BE THE PERPETUAL MAINTENANCE OBLIGATION OF SAID ASSOCIATION, ITS SUCCESSORS AND ASSIGNS, WITHOUT RECOURSE TO THE CITY OF WESTLAKE.

LIFT STATION EASEMENT

LIFT STATION EASEMENT, AS SHOWN HEREON, IS HEREBY DEDICATED TO THE SEMINOLE IMPROVEMENT DISTRICT, AN INDEPENDENT SPECIAL DISTRICT OF THE STATE OF FLORIDA, ITS SUCCESSORS AND ASSIGNS, AND IS THE PERPETUAL MAINTENANCE OBLIGATION OF SAID DISTRICT, ITS SUCCESSORS AND ASSIGNS, WITHOUT RECOURSE TO THE CITY OF WESTLAKE.

WATER MAIN EASEMENT

WATER MAIN EASEMENT, AS SHOWN HEREON, IS HEREBY DEDICATED TO THE SEMINOLE IMPROVEMENT DISTRICT, AN INDEPENDENT SPECIAL DISTRICT OF THE STATE OF FLORIDA, ITS SUCCESSORS AND ASSIGNS, AND IS THE PERPETUAL MAINTENANCE OBLIGATION OF SAID DISTRICT, ITS SUCCESSORS AND ASSIGNS, WITHOUT RECOURSE TO THE CITY OF WESTLAKE.

FORCE MAIN EASEMENT

FORCE MAIN EASEMENT, AS SHOWN HEREON, IS HEREBY DEDICATED TO THE SEMINOLE IMPROVEMENT DISTRICT, AN INDEPENDENT SPECIAL DISTRICT OF THE STATE OF FLORIDA, ITS SUCCESSORS AND ASSIGNS, AND IS THE PERPETUAL MAINTENANCE OBLIGATION OF SAID DISTRICT, ITS SUCCESSORS AND ASSIGNS, WITHOUT RECOURSE TO THE CITY OF WESTLAKE.

PRIVATE ACCESS EASEMENTS

THE PRIVATE ACCESS EASEMENTS, SHOWN HEREON ARE HEREBY DEDICATED TO TERRACES OF WESTLAKE HOMEOWNERS ASSOCIATION, INC., ITS SUCCESSORS AND ASSIGNS, AND OWNERS OF SUCH LOTS BENEFITTED BY THE EASEMENTS FOR THE CONTINUED PRIVATE USE FOR ACCESS, INGRESS, EGRESS AND OTHER PURPOSES NOT INCONSISTENT WITH THE DEDICATION AND SHALL BE THE PERPETUAL MAINTENANCE OBLIGATION OF SAID ASSOCIATION, WITHOUT RECOURSE TO THE CITY OF WESTLAKE.

DRAINAGE EASEMENTS

THE 20-FOOT-WIDE DRAINAGE EASEMENTS (D.E.) AS SHOWN HEREON IS HEREBY DEDICATED IN PERPETUITY TO THE SEMINOLE IMPROVEMENT DISTRICT, AN INDEPENDENT SPECIAL DISTRICT OF THE STATE OF FLORIDA, ITS SUCCESSORS AND ASSIGNS, IN PERPETUITY FOR DRAINAGE PURPOSES. THE MAINTENANCE OF ALL DRAINAGE FACILITIES LOCATED THEREIN SHALL BE THE PERPETUAL MAINTENANCE OBLIGATION OF THE SEMINOLE IMPROVEMENT DISTRICT WITHOUT RECOURSE TO THE CITY OF WESTLAKE.

CITY OF WESTLAKE SHALL HAVE THE RIGHT, BUT NOT THE OBLIGATION, TO MAINTAIN ANY PORTION OF THE DRAINAGE SYSTEM ENCOMPASSED BY THIS PLAT WHICH IS ASSOCIATED WITH THE DRAINAGE OF PUBLIC STREETS, INCLUDING THE RIGHT TO UTILIZE FOR DRAINAGE PURPOSES ANY AND ALL DRAINAGE, LAKE MAINTENANCE, AND LAKE MAINTENANCE ACCESS EASEMENTS, AND PRIVATE STREETS ASSOCIATED WITH SAID DRAINAGE SYSTEM.

TRACT "I"

TRACT "I", AS SHOWN HEREON, IS HEREBY RESERVED FOR MINTO PBLH, LLC, A FLORIDA LIMITED LIABILITY COMPANY, ITS SUCCESSORS AND ASSIGNS, FOR FUTURE DEVELOPMENT AND PURPOSES CONSISTENT WITH THE ZONING REGULATIONS OF THE CITY OF WESTLAKE, FLORIDA, AND IS THE PERPETUAL MAINTENANCE OBLIGATION OF SAID MINTO PBLH, LLC, ITS SUCCESSORS AND ASSIGNS, WITHOUT RECOURSE TO THE CITY OF WESTLAKE.

TRACT "I" IS ALSO DEDICATED AS A LAKE MAINTENANCE ACCESS EASEMENT, A DRAINAGE EASEMENT AND UTILITY EASEMENT TO THE SEMINOLE IMPROVEMENT DISTRICT, AN INDEPENDENT SPECIAL DISTRICT OF THE STATE OF FLORIDA, ITS SUCCESSORS AND ASSIGNS. THESE DEDICATIONS TO SEMINOLE IMPROVEMENT DISTRICT ARE TO SUNSET WITH THE RECORDING OF THE PLAT OF TERRACES OF WESTLAKE - PHASE II, WHEREIN THE LOCATION OF PERMANENT LAKE MAINTENANCE ACCESS EASEMENT, A DRAINAGE EASEMENT AND UTILITY EASEMENT SHALL BE IDENTIFIED AND GRANTED TO SEMINOLE IMPROVEMENT DISTRICT.

UTILITY EASEMENTS

ALL UTILITY EASEMENTS DESCRIBED ON THE PLAT ARE PRIVATE NON-EXCLUSIVE EASEMENTS UNLESS EXPRESSLY STATED OTHERWISE THEREIN. ALL UTILITY RIGHTS AND EASEMENTS ESTABLISHED BY OR RESERVED BY THIS PLAT ARE HEREBY DEDICATED IN PERPETUITY TO THE SEMINOLE IMPROVEMENT DISTRICT, (A LOCAL UNIT OF SPECIAL PURPOSE GOVERNMENT ESTABLISHED PURSUANT TO CHAPTERS 189 AND 298, FLORIDA STATUTES, AS A PUBLIC UTILITY PROVIDER OF WATER, SEWER AND RECLAIMED WATER), ITS SUCCESSORS AND ASSIGNS, SUBJECT TO THOSE CERTAIN RESTRICTION OF RIGHTS, COVENANTS AND DEDICATIONS AS MAY HEREAFTER BE IMPOSED BY GRANTOR; PROVIDED FURTHER SAID GRANTS OR ASSIGNMENTS SHALL NOT BE DEEMED A PUBLIC DEDICATION OF SAID RIGHTS OR EASEMENTS, THE SEMINOLE IMPROVEMENT DISTRICT SHALL HAVE THE RIGHT TO GRANT OTHER UTILITY PROVIDERS THE ABILITY TO USE THE EASEMENT, IN ITS SOLE DISCRETION.

IN FURTHERANCE OF THE FOREGOING, THERE IS HEREBY GRANTED TO FLORIDA POWER & LIGHT COMPANY, A FLORIDA CORPORATION, ITS AFFILIATES, LICENSEES, AGENTS, SUCCESSORS, AND ASSIGNS ("FPL"), A NON-EXCLUSIVE EASEMENT FOREVER OVER, UNDER, IN, ON, UPON AND ACROSS THE UTILITY EASEMENTS DESCRIBED ON THE PLAT, FOR THE CONSTRUCTION, OPERATION AND MAINTENANCE OF UNDERGROUND ELECTRIC UTILITY FACILITIES (INCLUDING CABLES, CONDUITS, APPURTENANT EQUIPMENT, AND APPURTENANT ABOVE-GROUND EQUIPMENT) TO BE INSTALLED FROM TIME TO TIME, TOGETHER WITH THE RIGHT TO PERMIT FPL TO ATTACH OR PLACE WIRES TO OR WITHIN ANY FACILITIES HEREUNDER AND LAY CABLE AND CONDUIT WITHIN THE EASEMENT AREA AND TO OPERATE THE SAME FOR FPL'S COMMUNICATIONS PURPOSES IN CONNECTION WITH ELECTRIC SERVICE AND THE RIGHT OF INGRESS AND EGRESS TO THE UTILITY EASEMENTS AT ALL TIMES.

IN WITNESS WHEREOF, MINTO PBLH, LLC, A FLORIDA LIMITED LIABILITY COMPANY HAS CAUSED THESE PRESENTS TO BE SIGNED BY ITS MANAGER AND ITS COMPANY SEAL TO BE AFFIXED HERETO BY AND WITH THE AUTHORITY OF ITS MEMBERS THIS ____ DAY OF _____, 2023.

WITNESS: _____ MINTO PBLH, LLC
A FLORIDA LIMITED LIABILITY COMPANY

PRINT NAME: _____ BY: _____
JOHN F. CARTER, MANAGER

WITNESS: _____

PRINT NAME: _____

ACKNOWLEDGEMENT

STATE OF FLORIDA
COUNTY OF PALM BEACH

THE FOREGOING INSTRUMENT WAS ACKNOWLEDGED BEFORE ME BY MEANS OF PHYSICAL PRESENCE OR ONLINE NOTARIZATION, THIS ____ DAY OF _____, 20____, BY JOHN CARTER, AS MANAGER FOR MINTO PBLH, LLC, A FLORIDA LIMITED LIABILITY COMPANY, ON BEHALF OF THE COMPANY, WHO IS PERSONALLY KNOWN TO ME OR HAS PRODUCED _____ AS IDENTIFICATION.

MY COMMISSION EXPIRES: _____ SIGNATURE _____
(PRINT NAME) - NOTARY PUBLIC

(SEAL)

ACCEPTANCE OF DEDICATION

STATE OF FLORIDA
COUNTY OF PALM BEACH

SEMINOLE IMPROVEMENT DISTRICT, AN INDEPENDENT SPECIAL DISTRICT OF THE STATE OF FLORIDA, HEREBY ACCEPTS THE DEDICATIONS AND RESERVATIONS TO SAID DISTRICT AS STATED AND SHOWN HEREON, AND ITS MAINTENANCE OBLIGATIONS FOR SAME, AND HEREBY JOINS IN AND CONSENTS TO THE UTILITY EASEMENTS DEDICATION, DATED THIS ____ DAY OF _____, 2023.

WITNESS: _____ SEMINOLE IMPROVEMENT DISTRICT
AN INDEPENDENT SPECIAL DISTRICT
OF THE STATE OF FLORIDA

PRINT NAME: _____ BY: _____
SCOTT MASSEY, PRESIDENT

WITNESS: _____

PRINT NAME: _____

ACKNOWLEDGEMENT

STATE OF FLORIDA
COUNTY OF PALM BEACH

THE FOREGOING INSTRUMENT WAS ACKNOWLEDGED BEFORE ME BY MEANS OF PHYSICAL PRESENCE OR ONLINE NOTARIZATION, THIS ____ DAY OF _____, 20____, BY SCOTT MASSEY AS PRESIDENT FOR SEMINOLE IMPROVEMENT DISTRICT, AN INDEPENDENT SPECIAL DISTRICT OF THE STATE OF FLORIDA, ON BEHALF OF THE DISTRICT, WHO IS PERSONALLY KNOWN TO ME OR HAS PRODUCED _____ AS IDENTIFICATION.

MY COMMISSION EXPIRES: _____ SIGNATURE _____
(PRINT NAME) - NOTARY PUBLIC

(SEAL)

ACCEPTANCE OF DEDICATION

STATE OF FLORIDA
COUNTY OF PALM BEACH

TERRACES OF WESTLAKE HOMEOWNERS ASSOCIATION, INC., ITS SUCCESSORS AND ASSIGNS, HEREBY ACCEPTS THE DEDICATIONS AND RESERVATIONS TO SAID ASSOCIATION AS STATED AND SHOWN HEREON, AND HEREBY ACCEPTS ITS MAINTENANCE OBLIGATIONS FOR SAME AS STATED HEREON, DATED THIS ____ DAY OF _____, 2023.

WITNESS: _____ TERRACES OF WESTLAKE
HOMEOWNERS ASSOCIATION, INC.
A FLORIDA CORPORATION NOT-FOR-PROFIT

PRINT NAME: _____ BY: _____
JOHN CARTER, PRESIDENT

WITNESS: _____

PRINT NAME: _____

ACKNOWLEDGEMENT

STATE OF FLORIDA
COUNTY OF PALM BEACH

THE FOREGOING INSTRUMENT WAS ACKNOWLEDGED BEFORE ME BY MEANS OF PHYSICAL PRESENCE OR ONLINE NOTARIZATION, THIS ____ DAY OF _____, 20____, BY JOHN CARTER, AS PRESIDENT FOR TERRACES OF WESTLAKE HOMEOWNERS ASSOCIATION, INC., ON BEHALF OF THE ASSOCIATION, WHO IS PERSONALLY KNOWN TO ME OR HAS PRODUCED _____ AS IDENTIFICATION.

MY COMMISSION EXPIRES: _____ SIGNATURE _____
(PRINT NAME) - NOTARY PUBLIC

(SEAL)

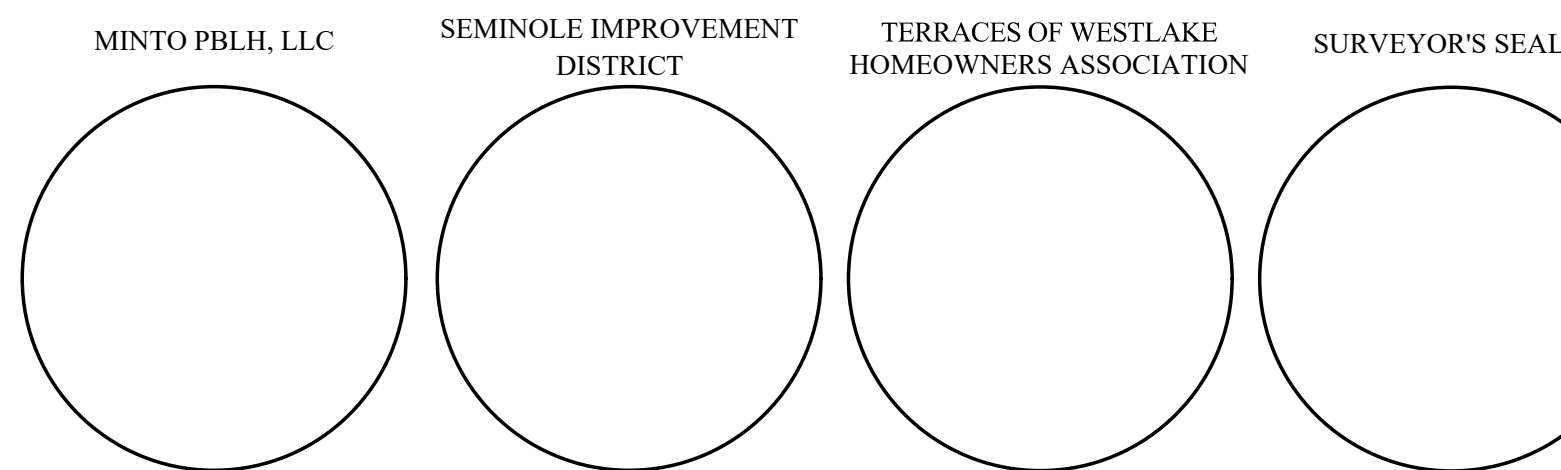

SURVEYORS NOTES

- PERMANENT REFERENCE MONUMENTS ARE SHOWN THUS: "■" A 1 1/2" BRASS DISK STAMPED "PRM LB7768" SET IN A 4"x4"x24" CONCRETE MONUMENT. PERMANENT CONTROL POINTS ARE SHOWN AS THUS: "●" A MAGNETIC NAIL AND DISK STAMPED "PCP LB7768". (UNLESS OTHERWISE NOTED)
- BEARINGS SHOWN HEREON ARE BASED ON THE NORTH BOUNDARY OF SECTION 6, TOWNSHIP 43 SOUTH, RANGE 41 EAST, HAVING A GRID BEARING OF S.89°48'53"E. BEARINGS SHOWN HEREON, REFER TO THE STATE PLANE COORDINATE SYSTEM, NORTH AMERICAN DATUM OF 1983 (NAD 83 / 07) FOR THE EAST ZONE OF FLORIDA. SAID BASIS OF BEARING IS THE SAME IN THE NORTH AMERICAN DATUM OF 1983 (NAD 83 / 90).
- NO BUILDING OR ANY KIND OF CONSTRUCTION OR TREES OR SHRUBS SHALL BE PLACED ON ANY EASEMENT WITHOUT PRIOR WRITTEN CONSENT OF ALL EASEMENT BENEFICIARIES AND ALL APPLICABLE CITY OR SEMINOLE IMPROVEMENT DISTRICT APPROVALS OR PERMITS AS REQUIRED FOR SUCH ENCROACHMENTS. THERE WILL BE NO ABOVE GROUND ENCROACHMENTS WHERE LAKE MAINTENANCE EASEMENTS AND UTILITY EASEMENTS OVERLAP.
- THE BUILDING SETBACKS SHALL BE AS REQUIRED BY THE CITY OF WESTLAKE ZONING REGULATIONS.
- NOTICE: THIS PLAT, AS RECORDED IN ITS GRAPHIC FORM, IS THE OFFICIAL DEPICTION OF THE SUBDIVIDED LANDS DESCRIBED HEREIN AND WILL IN NO CIRCUMSTANCES BE SUPPLANTED IN AUTHORITY BY ANY OTHER GRAPHIC OR DIGITAL FORM OF THE PLAT. THERE MAY BE ADDITIONAL RESTRICTIONS THAT ARE NOT RECORDED ON THIS PLAT THAT MAY BE FOUND IN THE PUBLIC RECORDS OF PALM BEACH COUNTY.
- IN THOSE CASES WHERE EASEMENTS OF DIFFERENT TYPES CROSS OR OTHERWISE COINCIDE, DRAINAGE EASEMENTS SHALL HAVE FIRST PRIORITY, UTILITY EASEMENTS SHALL HAVE SECOND PRIORITY, ACCESS EASEMENTS SHALL HAVE THIRD PRIORITY, AND ALL OTHER EASEMENTS SHALL BE SUBORDINATE TO THESE WITH THEIR PRIORITIES BEING DETERMINED BY USE RIGHTS GRANTED.
- ALL LINES INTERSECTING CIRCULAR CURVES ARE RADIAL UNLESS OTHERWISE NOTED.
- COORDINATES SHOWN HEREON ARE FLORIDA STATE PLANE GRID DATUM = NAD83 2007 ADJUSTMENT ZONE = FLORIDA EAST LINEAR UNITS = US SURVEY FEET COORDINATE SYSTEM = 1983 STATE PLANE PROJECTION = TRANSVERSE MERCATOR ALL DISTANCES ARE GROUND SCALE FACTOR: 1.0000 GROUND DISTANCE X SCALE FACTOR = GRID DISTANCE PLAT BEARING = GRID BEARING NO ROTATION ALL TIES TO SECTION CORNERS AND QUARTER CORNERS ARE GENERATED FROM MEASURED VALUES

SURVEYOR & MAPPER'S CERTIFICATE

THIS IS TO CERTIFY THAT THE PLAT SHOWN HEREON IS A TRUE AND CORRECT REPRESENTATION OF A SURVEY MADE UNDER MY RESPONSIBLE DIRECTION AND SUPERVISION; THAT SAID SURVEY IS ACCURATE TO THE BEST OF MY KNOWLEDGE AND BELIEF; THAT PERMANENT REFERENCE MONUMENTS ("P.R.M.S") HAVE BEEN PLACED AS REQUIRED BY LAW, AND THAT PERMANENT CONTROL POINTS ("P.C.P.S"), AND MONUMENTS ACCORDING TO SEC. 177.09(1), F.S., WILL BE SET UNDER THE GUARANTEES POSTED WITH THE CITY OF WESTLAKE FOR THE REQUIRED IMPROVEMENTS; AND, FURTHER, THAT THE SURVEY DATA COMPLIES WITH ALL THE REQUIREMENTS OF CHAPTER 177, FLORIDA STATUTES, AS AMENDED, AND THE ORDINANCES OF CITY OF WESTLAKE, FLORIDA.

DATE: _____ GARY A. RAGER, P.S.M.
LICENSE NO. LS4828
STATE OF FLORIDA

THIS INSTRUMENT PREPARED BY
GARY A. RAGER, P.S.M.
LS4828 STATE OF FLORIDA.
GEOPOINT SURVEYING, INC.
4152 WEST BLUE HERON BOULEVARD, SUITE 105,
RIVIERA BEACH, FLORIDA 33404.
CERTIFICATE OF AUTHORIZATION NO. LB7768



4152 W. Blue Heron Blvd. Phone: (561) 444-2720
Suite 105 www.geopointsurvey.com
Riviera Beach, FL 33404 Licensed Business Number LB 7768

TERRACES OF WESTLAKE - PHASE I
 BEING A REPLAT OF A PORTION OF TRACT "A", WESTLAKE POD I AND POD J, PLAT BOOK 130, PAGES 153 AND 154,
 PUBLIC RECORDS OF PALM BEACH COUNTY, FLORIDA, LYING IN SECTION 12, TOWNSHIP 43 SOUTH, RANGE 40 EAST,
 CITY OF WESTLAKE, PALM BEACH COUNTY, FLORIDA.

CITY OF WESTLAKE'S APPROVAL

THIS CERTIFIES THAT THIS PLAT HAS BEEN ACCEPTED AND APPROVED BY THE CITY COUNCIL FOR THE CITY OF WESTLAKE BY A RESOLUTION DULY ADOPTED BY THE CITY COUNCIL THIS _____ DAY OF _____, 2023, IN ACCORDANCE WITH SEC. 177.071(2), F.S., AND HAS BEEN REVIEWED BY A PROFESSIONAL SURVEYOR & MAPPER EMPLOYED BY THE CITY OF WESTLAKE IN ACCORDANCE WITH SEC. 177.081(1), F.S.

ATTEST: _____ BY: _____
 CITY MANAGER, KEN CASSEL CITY MAYOR, JOHN PAUL O'CONNOR

TITLE CERTIFICATION

STATE OF FLORIDA _____
 COUNTY OF _____

I, _____, A DULY LICENSED ATTORNEY IN THE STATE OF FLORIDA DO HEREBY CERTIFY THAT I HAVE EXAMINED THE TITLE TO THE HEREON DESCRIBED PROPERTY; THAT I FIND THE TITLE TO THE PROPERTY IS VESTED IN MINTO PBLH, LLC; THAT THE CURRENT TAXES HAVE BEEN PAID; AND THAT ALL PALM BEACH COUNTY SPECIAL ASSESSMENT ITEMS, AND ALL OTHER ITEMS HELD AGAINST SAID LANDS HAVE BEEN SATISFIED; THAT ALL MORTGAGES NOT SATISFIED OR RELEASED OF RECORD NOR OTHERWISE TERMINATED BY LAW ARE SHOWN HEREON; AND THAT THERE ARE ENCUMBRANCES OF RECORD BUT THOSE ENCUMBRANCES DO NOT PROHIBIT THE CREATION OF THE SUBDIVISION DEPICTED BY THIS PLAT.

DATED: THIS _____ DAY OF _____, 2023
 PRINT NAME: _____
 ATTORNEY-AT-LAW LICENSED IN FLORIDA
 BAR NO. _____

AREA TABULATION (IN ACRES)

SINGLE FAMILY LOTS (109 LOTS):	7.022
ROADWAY TRACT "A":	3.267
ALLEYWAY TRACT "B-1":	0.147
ALLEYWAY TRACT "B-2":	0.086
ALLEYWAY TRACT "B-3":	0.085
OPEN SPACE TRACT #1:	0.315
OPEN SPACE TRACT #2:	0.481
OPEN SPACE TRACT #3:	0.180
OPEN SPACE TRACT #4:	0.461
OPEN SPACE TRACT #5:	0.144
TRACT "I":	10.971
 TOTAL ACRES, MORE OR LESS:	 23.159

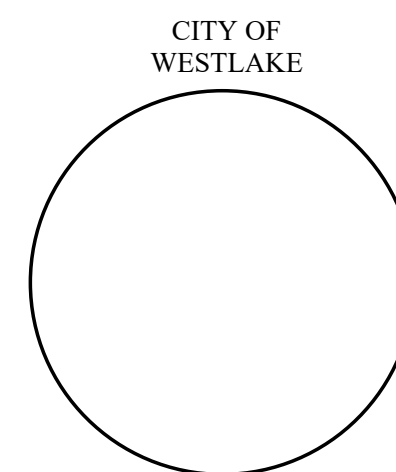

4152 W. Blue Heron Blvd. Phone: (561) 444-2720
 Suite 105 www.geopointsurvey.com
 Riviera Beach, FL 33404 Licensed Business Number LB 7768

TERRACES OF WESTLAKE - PHASE I

BEING A REPLAT OF A PORTION OF TRACT "A", WESTLAKE POD I AND POD J, PLAT BOOK 130, PAGES 153 AND 154, PUBLIC RECORDS OF PALM BEACH COUNTY, FLORIDA, LYING IN SECTION 12, TOWNSHIP 43 SOUTH, RANGE 40 EAST, CITY OF WESTLAKE, PALM BEACH COUNTY, FLORIDA.

NORTH EAST CORNER OF SECTION 1, TOWNSHIP 43 S., RANGE 40 E. SET 3.5" IRON PIPE "PUBLIC LAND SURVEY CORNER-TALLAHASSEE MERIDIAN" BRASS DISK "10" EAST" SET IN CONCRETE / FOUND 10' EAST ON SECTION LINE N: 884626.7147 - E: 886137.1629 NAD83 (2007 ADJUSTMENT) / CERTIFIED CORNER RECORD #107597

SOUTH LINE OF SECTION 31, TOWNSHIP 42 S., RANGE 41 E.

BASIS OF BEARING
NORTH BOUNDARY OF SECTION 6, TOWNSHIP 43 S., RANGE 41 E. S.89°48'53"E, 5270.23' (MEASURED) S.89°48'52"E, 5270.39' (COUNTY)

NORTHWEST CORNER OF SECTION 1, TOWNSHIP 43 S., RANGE 40 E. FOUND BRASS DISK IN CONCRETE "P.B.C." N: 884612.3300 - E: 880484.6585 NAD83 (2007 ADJUSTMENT) CERTIFIED CORNER RECORD #107585

NORTHEAST CORNER SECTION 6-43-41 FOUND BRASS DISK IN CONCRETE "P.B.C." N:884609.6818 E:891407.3638 NAD83 (2007 ADJUSTMENT) CERTIFIED CORNER RECORD #107591

WEST LINE OF SECTION 1, TOWNSHIP 43 S., RANGE 40 E

ORIGINAL EAST R/W LINE OF SEMINOLE-PRATT WHITNEY ROAD (O.R.B. 1544, PG. 378) (O.R.B. 1640, PG. 1626) (R.P.B. 4, PG. 34)

W.M.T. #2 WESTLAKE POD I AND POD J (P.B. 130, PG(s). 153 & 154)

P.O.B. - NORTHEAST CORNER OF TRACT "A" WESTLAKE POD I AND POD J (P.B. 130, PG(s). 153 & 154) N: 877702.1853 E: 884129.4613

GROVES OF WESTLAKE PHASE I (P.B. 130, PG(s). 120 - 135)

NORTHERLY EXTENSION OF WEST BOUNDARY OF THE EAST QUARTER (1/4) OF SECTION 12-43-40 AS DESCRIBED IN FINAL JUDGEMENT (CASE NO.: 73 1016 CA (L) 01 MACMILLAN)

W.M.T. #1 WESTLAKE POD I AND POD J (P.B. 130, PG(s). 153 & 154)

EAST LINE OF TRACT "A", POD I AND POD J (P.B. 130, PG(s). 153 & 154)

EASTERLY BOUNDARY OF CITY OF WESTLAKE

W.M.T. #1 WESTLAKE POD I AND POD J (P.B. 130, PG(s). 153 & 154)

TRACT "A" WESTLAKE POD I AND POD J (P.B. 130, PG(s). 153 & 154)

CHRIST FELLOWSHIP CHURCH, INC. (P.B. 129, PG(s). 138 & 139)

WATERS EDGE DRIVE (P.B. 128, PG(s). 29-30)

KEY SHEET

NOTE: REFER TO THE FOLLOWING SHEETS OF THIS PLAT FOR DETAILED LABELING AND DIMENSIONING.

BASIS OF BEARINGS

BEARINGS SHOWN HEREON ARE BASED ON THE NORTH BOUNDARY OF SECTION 6, TOWNSHIP 43 SOUTH, RANGE 41 EAST, HAVING A GRID BEARING OF S.89°48'53"E. (MEASURED), BEARINGS SHOWN HEREON, REFER TO THE STATE PLANE COORDINATE SYSTEM, NORTH AMERICA DATUM OF 1983 (NAD 83 - '07) FOR THE EAST ZONE OF FLORIDA. SAID BASIS OF BEARING IS THE SAME IN THE NORTH AMERICAN DATUM OF 1983 (NAD 83 - '90).

NOTICE:
THIS PLAT, AS RECORDED IN ITS GRAPHIC FORM, IS THE OFFICIAL DEPICTION OF THE SUBDIVIDED LANDS DESCRIBED HEREIN AND WILL IN NO CIRCUMSTANCES BE SUPPLANTED IN AUTHORITY BY ANY OTHER GRAPHIC OR DIGITAL FORM OF THE PLAT. THERE MAY BE ADDITIONAL RESTRICTIONS THAT ARE NOT RECORDED ON THIS PLAT THAT MAY BE FOUND IN THE PUBLIC RECORDS OF THIS COUNTY.

NOTE: EASEMENTS, BUFFERS AND OTHER SUCH LABELS AND DIMENSIONS OF A PARALLEL NATURE AS SHOWN HEREON AND INDICATED TO THE NEAREST FOOT (IE: 5' UTILITY EASEMENT) ARE ASSUMED TO BE THE SAME DIMENSION EXTENDED TO THE NEAREST HUNDREDTH OF A FOOT WITH NO GREATER OR LESSER VALUE (IE: 5' = 5.00') (IE: 7.5' = 7.50')

COORDINATES SHOWN HEREON ARE FLORIDA STATE PLANE GRID DATUM = NAD83 2007 ADJUSTMENT
ZONE = FLORIDA EAST
LINEAR UNITS = US SURVEY FEET
COORDINATE SYSTEM = 1983 STATE PLANE
PROJECTION = TRANSVERSE MERCATOR
ALL DISTANCES ARE GROUND
SCALE FACTOR: 1.0000
GROUND DISTANCE X SCALE FACTOR = GRID DISTANCE
PLAT BEARING = GRID BEARING
NO ROTATION
ALL TIES TO SECTION CORNERS AND QUARTER CORNERS ARE GENERATED FROM MEASURED VALUES

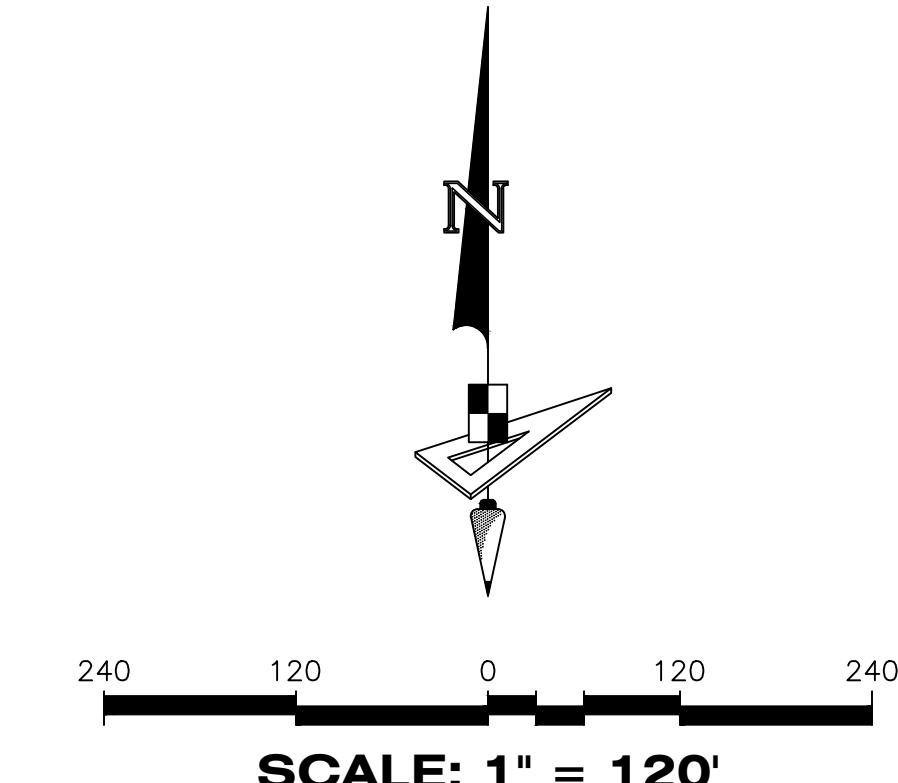

LEGEND	
P.O.B. -----	POINT OF BEGINNING
P.O.C. -----	POINT OF COMMENCEMENT
P.B. -----	PLAT BOOK
D.B. -----	DEED BOOK
R.P.B. -----	ROAD PLAT BOOK
O.R./O.R.B. -----	OFFICIAL RECORDS BOOK
PG./PG(s) -----	PAGE(S)
NAD -----	NORTH AMERICAN DATUM
W.M.T. -----	WATER MANAGEMENT TRACT
O.S.T. -----	OPEN SPACE TRACT
P.B.C. -----	PALM BEACH COUNTY
U.E. -----	UTILITY EASEMENT
D.E. -----	DRAINAGE EASEMENT
F.M.E. -----	FORCE MAIN EASEMENT
W.M.E. -----	WATER MAIN EASEMENT
12-43-40 -----	SECTION-TOWNSHIP-RANGE
AC.±/AC± -----	ACRES
LB -----	LICENSED BUSINESS
R -----	RADIUS
L -----	ARC LENGTH
D -----	DELTA ANGLE
CB -----	CHORD BEARING
C -----	CHORD
Ⓢ -----	CENTER LINE OF ROAD
N.T. -----	NON-TANGENT
N.T.C. -----	NON-TANGENT CURVATURE
N.T.I. -----	NON-TANGENT INTERSECTION
P.C. -----	POINT OF CURVATURE
P.T. -----	POINT OF TANGENCY
R.C. -----	REVERSE CURVATURE
R/W -----	RIGHT-OF-WAY
HOA -----	HOMEOWNERS ASSOCIATION
S.I.D. -----	SEMINOLE IMPROVEMENT DISTRICT
PRM -----	PERMANENT REFERENCE MONUMENT
● -----	PERMANENT CONTROL POINT
□ -----	FOUND PERMANENT REFERENCE MONUMENT
■ -----	SET 4"x4" CONCRETE MONUMENT WITH 2" ALUMINUM DISK STAMPED "PRM LB 7768"

GeoPoint
Surveying, Inc.

4152 W. Blue Heron Blvd. Suite 105
Riviera Beach, FL 33404
Phone: (561) 444-2720
www.geopointsurvey.com
Licensed Business Number LB 7768

Sheet No. 03 of 07 Sheets

TERRACES OF WESTLAKE - PHASE I

BEING A REPLAT OF A PORTION OF TRACT "A", WESTLAKE POD I AND POD J, PLAT BOOK 130, PAGES 153 AND 154, PUBLIC RECORDS OF PALM BEACH COUNTY, FLORIDA, LYING IN SECTION 12, TOWNSHIP 43 SOUTH, RANGE 40 EAST, CITY OF WESTLAKE, PALM BEACH COUNTY, FLORIDA.

DETAIL "A" (SCALE: 1"=20')

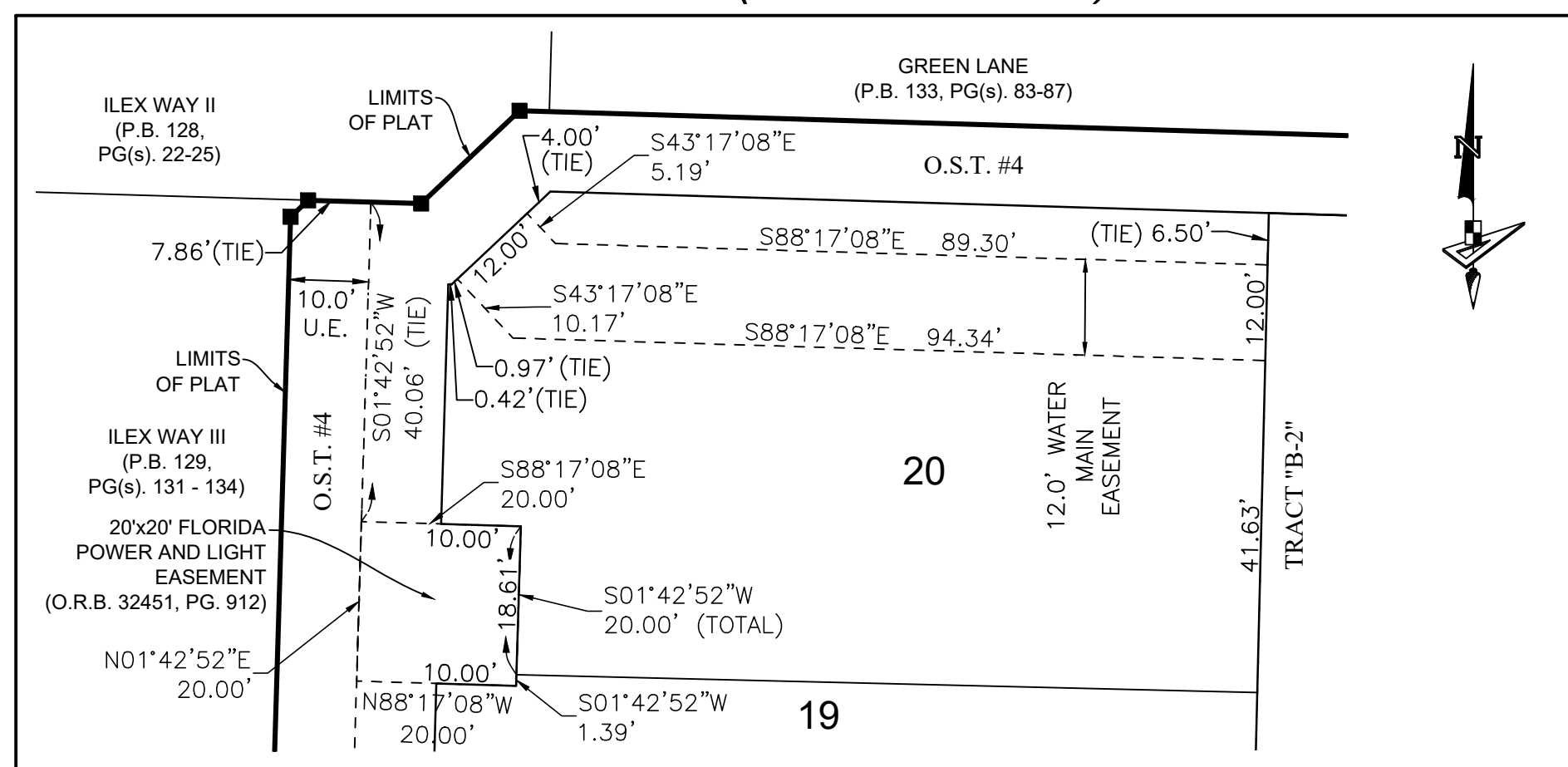

DETAIL "B" (SCALE: 1"=20')

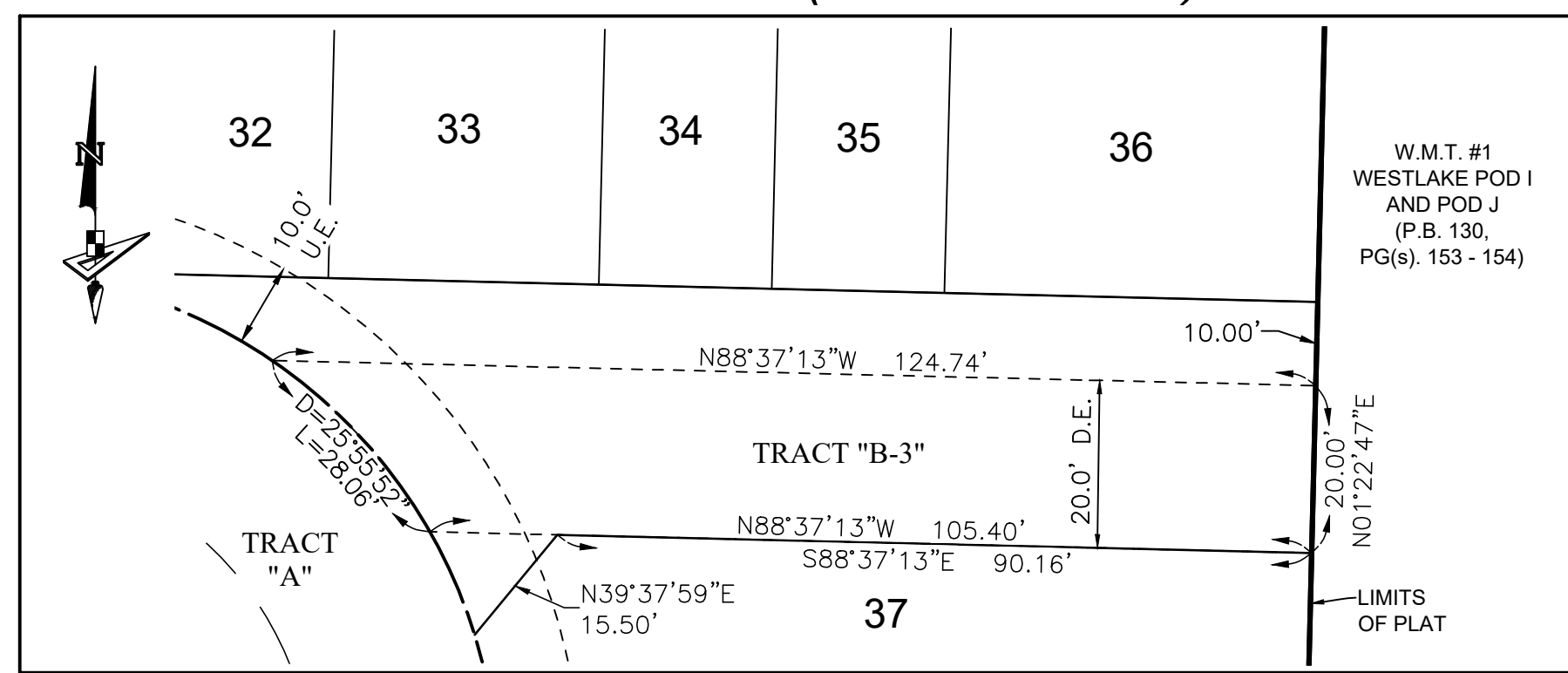

POINT OF COMMENCEMENT
NORTHEAST CORNER OF SECTION 1,
TOWNSHIP 43 S., RANGE 40 E.
SET 3.5" IRON PIPE "PUBLIC LAND SURVEY
CORNER-TALLAHASSEE MERIDIAN"
BRASS DISK "10' EAST" SET IN CONCRETE
FOUND 10' EAST ON SECTION LINE
N: 884626.7147 / E: 886137.1629
NAD83 (2007 ADJUSTMENT)
CERTIFIED CORNER RECORD #107597

SOUTH LINE OF SECTION 31,
TOWNSHIP 42 S., RANGE 41 E.

BASIS OF BEARINGS
NORTH BOUNDARY OF SECTION 6,
TOWNSHIP 43 S., RANGE 41 E.
S: 89°48'53"E, 5270.23' (MEASURED)
S: 89°48'52"E, 5270.39' (COUNTY)

NORTHEAST CORNER
SECTION 6-43-41
FOUND BRASS DISK IN
CONCRETE "P.B.C."
N: 884609.6818 E: 891407.3638
NAD83 (2007 ADJUSTMENT)
CERTIFIED CORNER
RECORD #107591

NORTH BOUNDARY OF SECTION 1,
TOWNSHIP 43 S., RANGE 40 E.

EAST LINE OF
SECTION 1-43-40

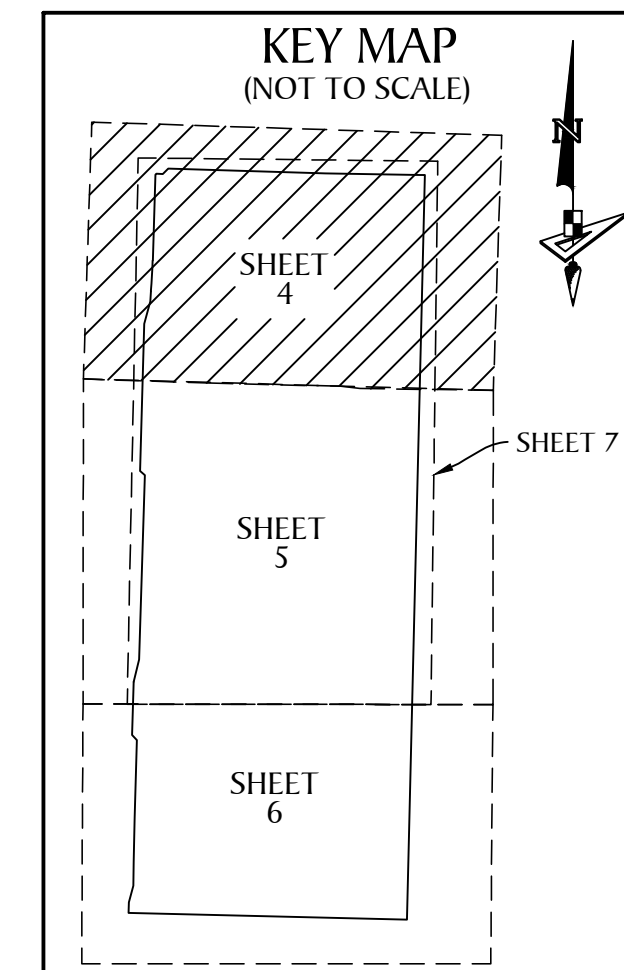
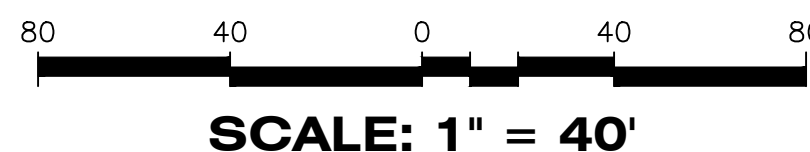

PACKING HOUSE
(P.B. 128, PG(s). 26-28)

W.M.T. #2
WESTLAKE POD I
AND POD J
(P.B. 130, PG(s). 153 & 154)

SKY COVE SOUTH
PHASE 1A
(P.B. 131, PG(s). 170-178)

(SEE SHEET 7 FOR
DETAIL OF PRIVATE
ACCESS EASEMENT)

POINT OF BEGINNING
NORTHEAST CORNER
OF TRACT "A"
WESTLAKE POD I AND POD J
(P.B. 130, PG(s). 153 & 154)
N: 877702.1853
E: 884129.4613

LEGEND

- P.O.B. ----- POINT OF BEGINNING
- P.O.C. ----- POINT OF COMMENCEMENT
- P.B. ----- PLAT BOOK
- D.B. ----- DEED BOOK
- R.P.B. ----- ROAD PLAT BOOK
- O.R./O.R.B. ----- OFFICIAL RECORDS BOOK
- PG./PG(S) ----- PAGE(S)
- NAD ----- NORTH AMERICAN DATUM
- W.M.T. ----- WATER MANAGEMENT TRACT
- O.S.T. ----- OPEN SPACE TRACT
- P.B.C. ----- PALM BEACH COUNTY
- U.E. ----- UTILITY EASEMENT
- D.E. ----- DRAINAGE EASEMENT
- F.M.E. ----- FORCE MAIN EASEMENT
- W.M.E. ----- WATER MAIN EASEMENT
- 12-43-40 ----- SECTION-TOWNSHIP-RANGE
- AC.±/AC± ----- ACRES
- LB ----- LICENSED BUSINESS
- R ----- RADIUS
- L ----- ARC LENGTH
- D ----- DELTA ANGLE
- CB ----- CHORD BEARING
- C ----- CHORD
- CL ----- CENTER LINE OF ROAD
- N.T. ----- NON-TANGENT
- N.T.C. ----- NON-TANGENT CURVATURE
- N.T.I. ----- NON-TANGENT INTERSECTION
- P.C. ----- POINT OF CURVATURE
- P.T. ----- POINT OF TANGENCY
- R.C. ----- REVERSE CURVATURE
- R/W ----- RIGHT-OF-WAY
- HOA ----- HOMEOWNERS ASSOCIATION
- S.I.D. ----- SEMINOLE IMPROVEMENT DISTRICT
- PRM ----- PERMANENT REFERENCE MONUMENT
- ----- PERMANENT CONTROL POINT
- ----- FOUND PERMANENT REFERENCE MONUMENT
- ----- SET 4"x4" CONCRETE MONUMENT WITH 2" ALUMINUM DISK STAMPED "PRM LB 7768"

CURVE DATA TABLE

NO.	RADIUS	DELTA	ARC	CHORD	BEARING
C3	40.00'	90°00'00"	62.83'	56.57'	S 46°22'47" W
C4	40.00'	90°00'00"	62.83'	56.57'	N 43°37'13" W

CURVE DATA TABLE

NO.	RADIUS	DELTA	ARC
C12	18.00'	90°00'00"	28.27'
C13	18.00'	90°00'00"	28.27'

(SEE SHEET 7 FOR
DETAIL OF PRIVATE
ACCESS EASEMENT)

(SEE SHEET 7 FOR
DETAIL OF PRIVATE
ACCESS EASEMENT)

(SEE SHEET 7 FOR
DETAIL OF PRIVATE
ACCESS EASEMENT)

MATCH LINE SEE SHEET 5



TERRACES OF WESTLAKE - PHASE I

BEING A REPLAT OF A PORTION OF TRACT "A", WESTLAKE POD I AND POD J, PLAT BOOK 130, PAGES 153 AND 154, PUBLIC RECORDS OF PALM BEACH COUNTY, FLORIDA, LYING IN SECTION 12, TOWNSHIP 43 SOUTH, RANGE 40 EAST, CITY OF WESTLAKE, PALM BEACH COUNTY, FLORIDA.

LEGEND

- | | | | |
|---|---------------------------------------|---------------------------------------|---|
| P.O.B. ----- POINT OF BEGINNING | O.S.T. ----- OPEN SPACE TRACT | R ----- RADIUS | P.T. ----- POINT OF TANGENCY |
| P.O.C. ----- POINT OF COMMENCEMENT | P.B.C. ----- PALM BEACH COUNTY | L ----- ARC LENGTH | R.C. ----- REVERSE CURVATURE |
| P.B. ----- PLAT BOOK | U.E. ----- UTILITY EASEMENT | D ----- DELTA ANGLE | R/W ----- RIGHT-OF-WAY |
| D.B. ----- DEED BOOK | D.E. ----- DRAINAGE EASEMENT | CB ----- CHORD BEARING | HOA ----- HOMEOWNERS ASSOCIATION |
| R.P.B. ----- ROAD PLAT BOOK | F.M.E. ----- FORCE MAIN EASEMENT | C ----- CHORD | S.I.D. ----- SEMINOLE IMPROVEMENT DISTRICT |
| O.R./O.R.B. ----- OFFICIAL RECORDS BOOK | W.M.E. ----- WATER MAIN EASEMENT | CL ----- CENTER LINE OF ROAD | PRM ----- PERMANENT REFERENCE MONUMENT |
| PG./PG(s) ----- PAGE(S) | 12-43-40 ----- SECTION-TOWNSHIP-RANGE | N.T. ----- NON-TANGENT | ● ----- PERMANENT CONTROL POINT |
| NAD ----- NORTH AMERICAN DATUM | AC.±/AC± ----- ACRES | N.T.C. ----- NON-TANGENT CURVATURE | □ ----- FOUND PERMANENT REFERENCE MONUMENT |
| W.M.T. ----- WATER MANAGEMENT TRACT | LB ----- LICENSED BUSINESS | N.T.I. ----- NON-TANGENT INTERSECTION | ■ ----- SET 4"x4" CONCRETE MONUMENT WITH 2" ALUMINUM DISK STAMPED "PRM LB 7768" |
| | | P.C. ----- POINT OF CURVATURE | |

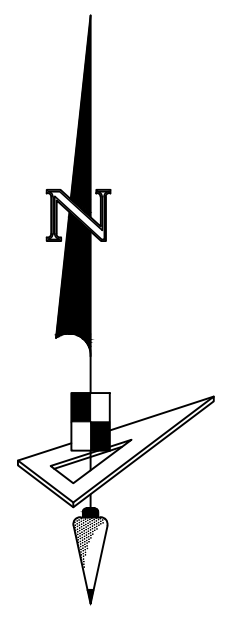

SCALE: 1" = 40'

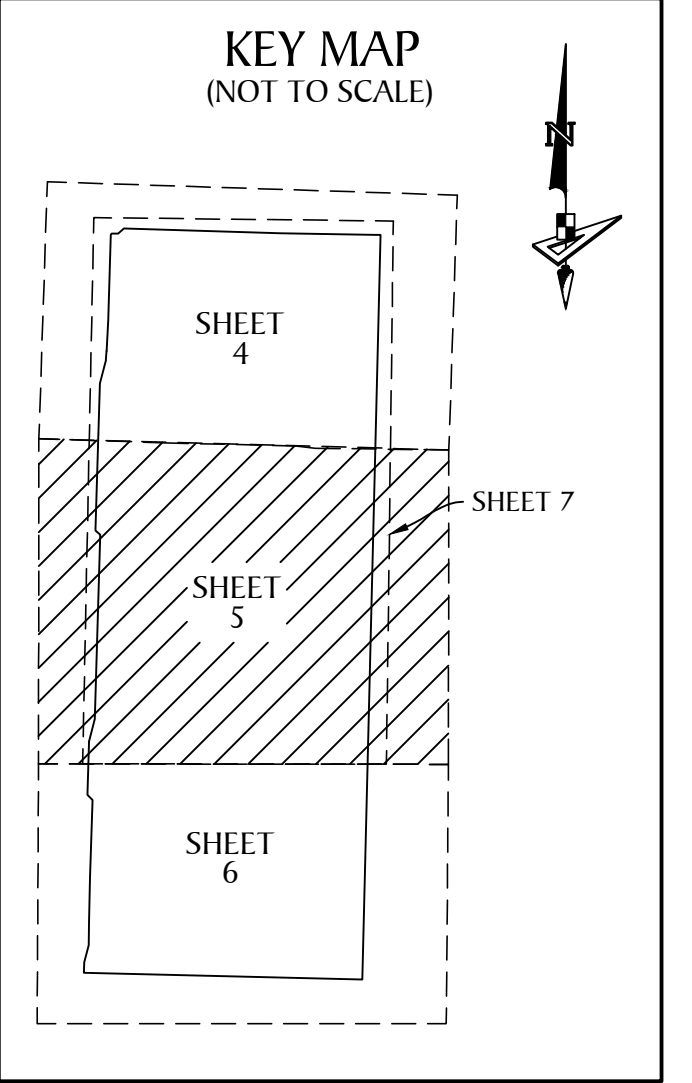

W.M.T. #2
WESTLAKE POD I
AND POD J
(P.B. 130, PG(s). 153 & 154)

EAST-WEST
QUARTER (1/4)
LINE OF SECTION 12,
TOWNSHIP 43 SOUTH,
RANGE 40 EAST

TRACT "B"
WESTLAKE POD I
AND POD J
(P.B. 130, PG(s). 153 & 154)

NO.	RADIUS	DELTA	ARC	CHORD	BEARING
C1	40.00'	90°00'00"	62.83'	56.57'	S 46°22'47" W
C2	40.00'	90°00'00"	62.83'	56.57'	S 43°37'13" E

NO.	RADIUS	DELTA	ARC
C5	8.00'	90°00'00"	12.57'
C6	8.00'	90°00'00"	12.57'
C7	8.00'	90°00'00"	12.57'
C8	8.00'	90°00'00"	12.57'
C9	18.00'	90°00'00"	28.27'
C10	18.00'	90°00'00"	28.27'
C11	62.00'	90°00'00"	97.39'
C14	72.00'	11°55'11"	14.98'
C15	72.00'	6°48'53"	8.56'

TRACT "B"
WESTLAKE POD I
AND POD J
(P.B. 130, PG(s). 153 & 154)

(SEE SHEET 7 FOR DETAIL OF PRIVATE ACCESS EASEMENT)

MATCH LINE SEE SHEET 4

(SEE SHEET 7 FOR DETAIL OF PRIVATE ACCESS EASEMENT)

(SEE SHEET 7 FOR DETAIL OF PRIVATE ACCESS EASEMENT)

DETAIL "C" (SCALE: 1"=30')

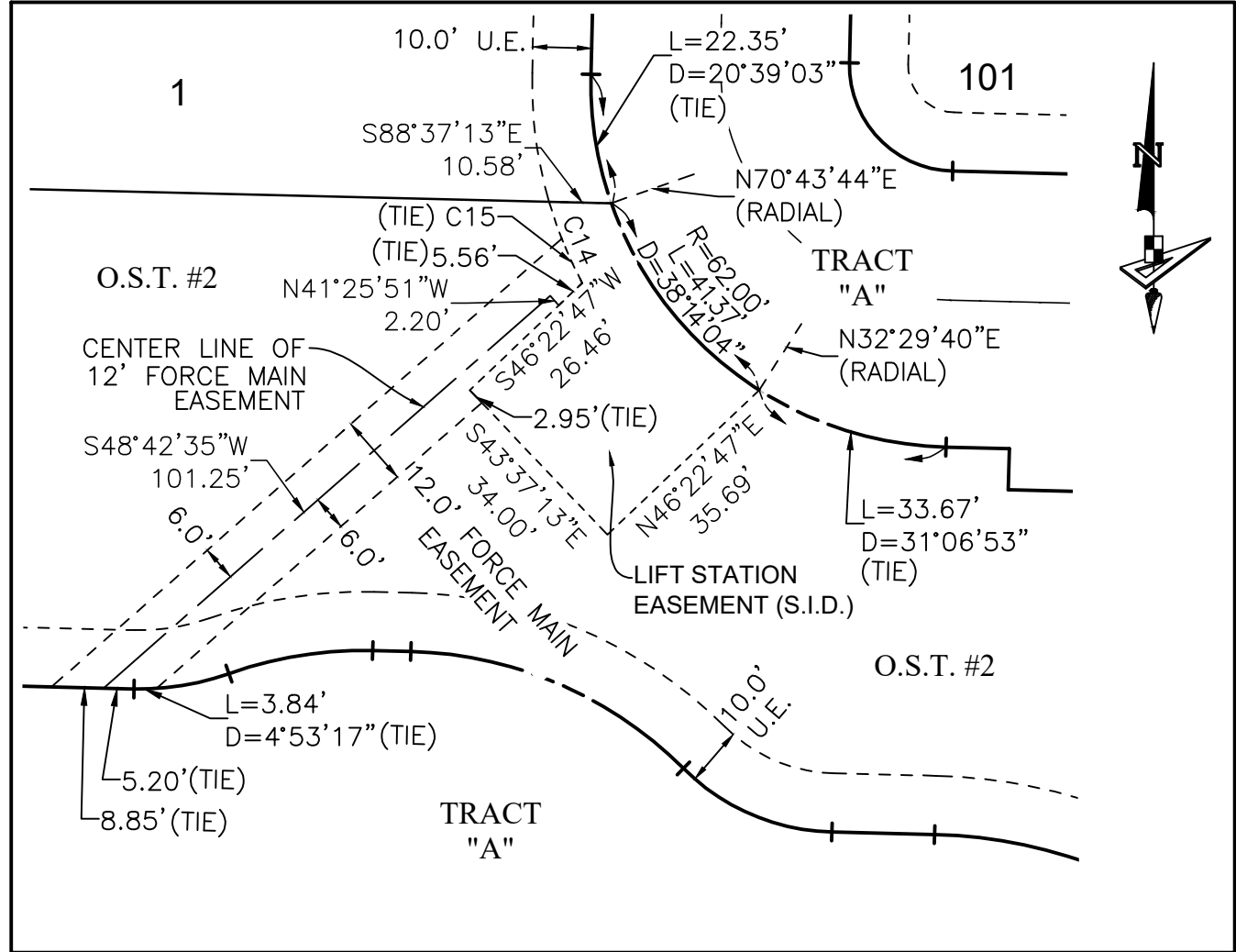

DETAIL "D" (SCALE: 1"=20')

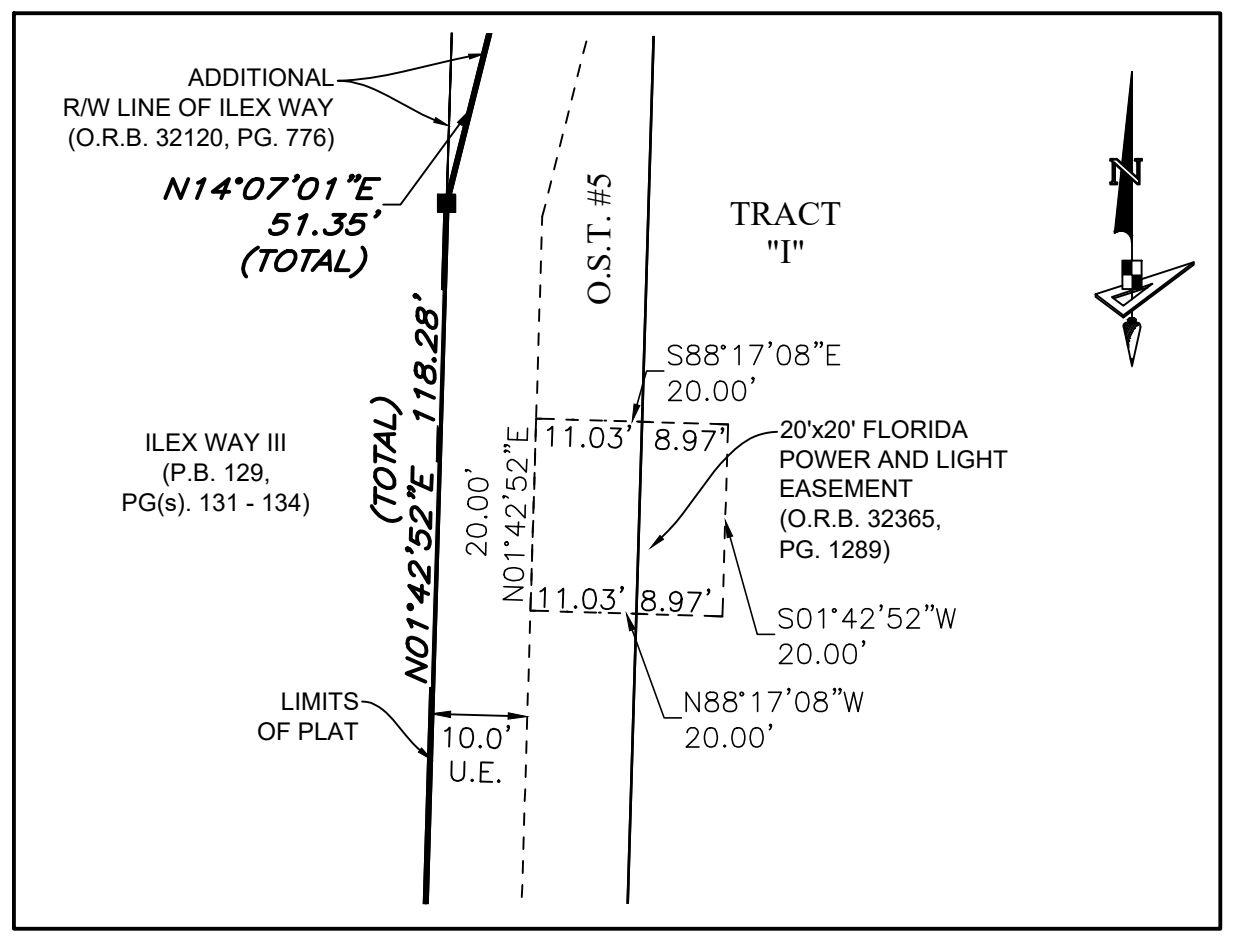

MATCH LINE SEE SHEET 6

TERRACES OF WESTLAKE - PHASE I

BEING A REPLAT OF A PORTION OF TRACT "A", WESTLAKE POD I AND POD J, PLAT BOOK 130, PAGES 153 AND 154,
PUBLIC RECORDS OF PALM BEACH COUNTY, FLORIDA, LYING IN SECTION 12, TOWNSHIP 43 SOUTH, RANGE 40 EAST,
CITY OF WESTLAKE, PALM BEACH COUNTY, FLORIDA.

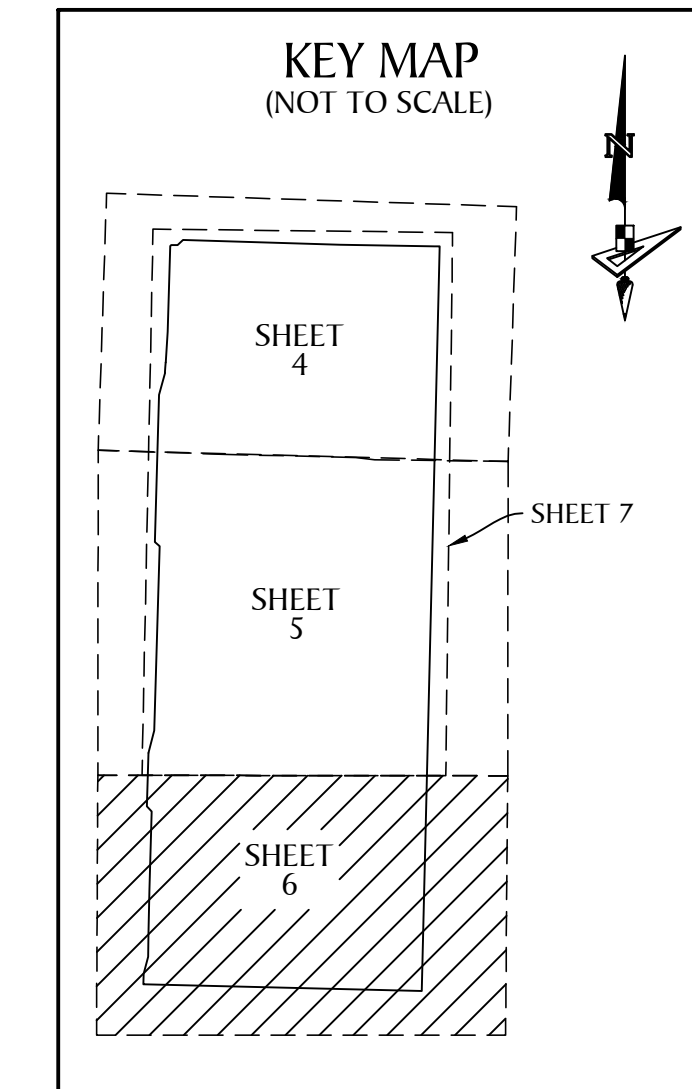
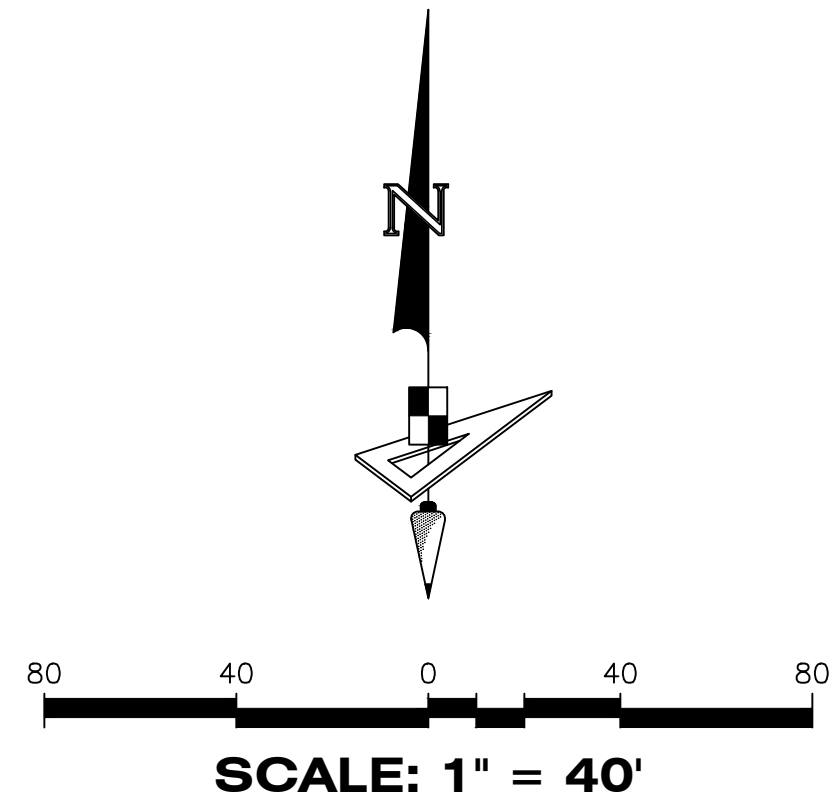

MATCH LINE SEE SHEET 5

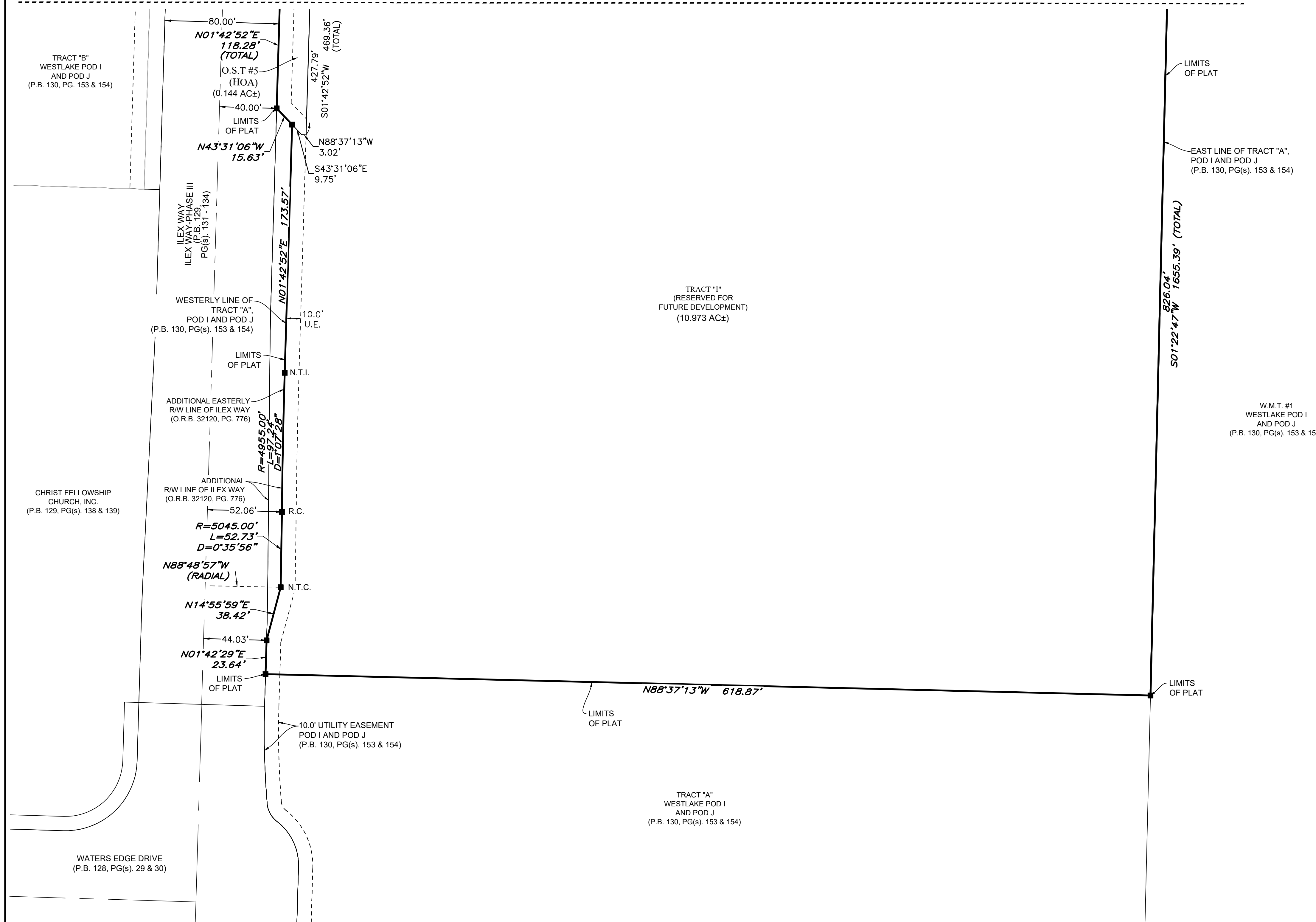

LEGEND

- P.O.B. ----- POINT OF BEGINNING
- P.O.C. ----- POINT OF COMMENCEMENT
- P.B. ----- PLAT BOOK
- D.B. ----- DEED BOOK
- R.P.B. ----- ROAD PLAT BOOK
- O.R./O.R.B. ----- OFFICIAL RECORDS BOOK
- PG./PG(s) ----- PAGE(s)
- NAD ----- NORTH AMERICAN DATUM
- W.M.T. ----- WATER MANAGEMENT TRACT
- O.S.T. ----- OPEN SPACE TRACT
- P.B.C. ----- PALM BEACH COUNTY
- U.E. ----- UTILITY EASEMENT
- D.E. ----- DRAINAGE EASEMENT
- F.M.E. ----- FORCE MAIN EASEMENT
- W.M.E. ----- WATER MAIN EASEMENT
- 12-43-40 ----- SECTION-TOWNSHIP-RANGE
- AC.±/AC± ----- ACRES
- LB ----- LICENSED BUSINESS
- R ----- RADIUS
- L ----- ARC LENGTH
- D ----- DELTA ANGLE
- CB ----- CHORD BEARING
- C ----- CHORD
- CL ----- CENTER LINE OF ROAD
- N.T. ----- NON-TANGENT
- N.T.C. ----- NON-TANGENT CURVATURE
- N.T.I. ----- NON-TANGENT INTERSECTION
- P.C. ----- POINT OF CURVATURE
- P.T. ----- POINT OF TANGENCY
- R.C. ----- REVERSE CURVATURE
- R/W ----- RIGHT-OF-WAY
- HOA ----- HOMEOWNERS ASSOCIATION
- S.I.D. ----- SEMINOLE IMPROVEMENT DISTRICT
- PRM ----- PERMANENT REFERENCE MONUMENT
- ----- PERMANENT CONTROL POINT
- ----- FOUND PERMANENT REFERENCE MONUMENT
- ----- SET 4"x4" CONCRETE MONUMENT WITH 2" ALUMINUM DISK STAMPED "PRM LB 7768"

TERRACES OF WESTLAKE - PHASE I

BEING A REPLAT OF A PORTION OF TRACT "A", WESTLAKE POD I AND POD J, PLAT BOOK 130, PAGES 153 AND 154, PUBLIC RECORDS OF PALM BEACH COUNTY, FLORIDA, LYING IN SECTION 12, TOWNSHIP 43 SOUTH, RANGE 40 EAST, CITY OF WESTLAKE, PALM BEACH COUNTY, FLORIDA.

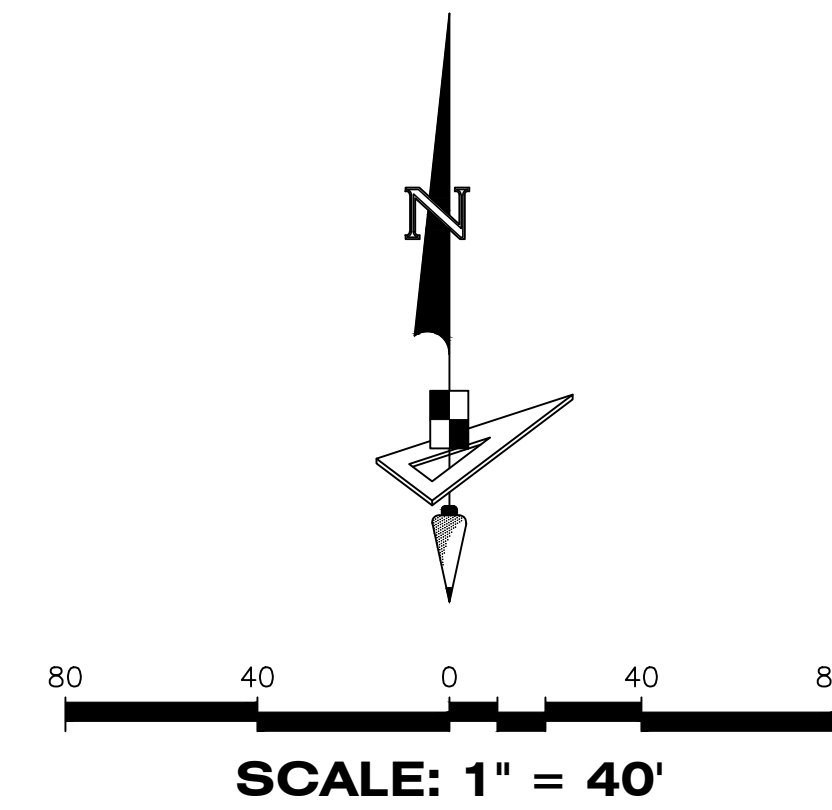
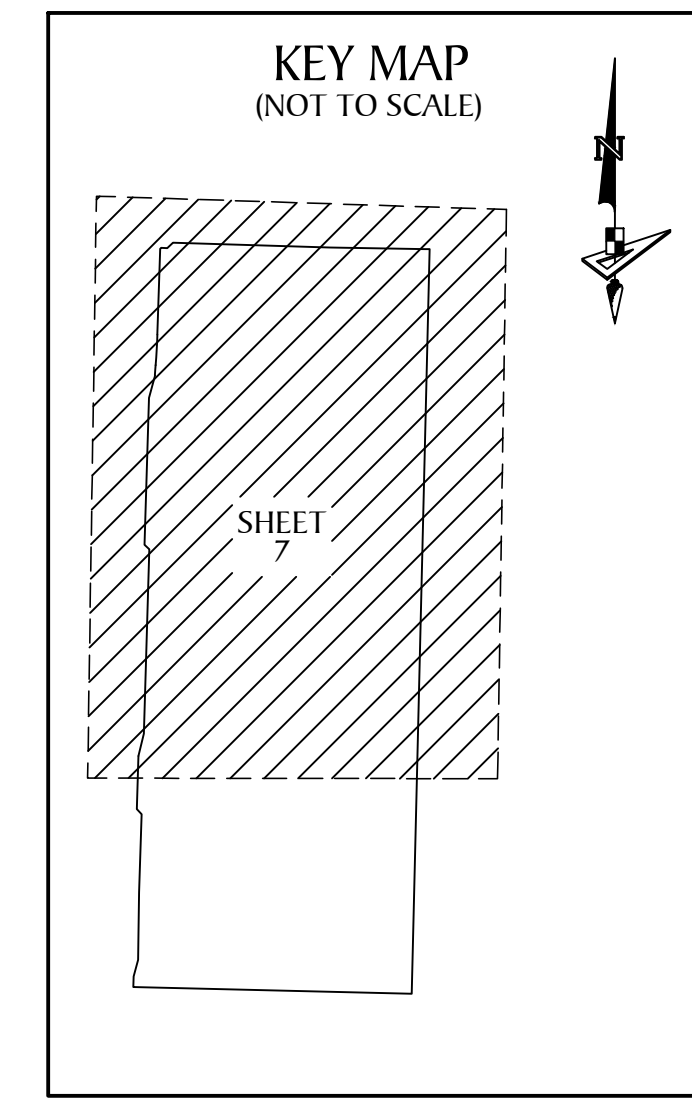

**PRIVATE ACCESS
EASEMENT
DETAIL SHEET**

LEGEND

- P.O.B. ----- POINT OF BEGINNING
- P.O.C. ----- POINT OF COMMENCEMENT
- P.B. ----- PLAT BOOK
- D.B. ----- DEED BOOK
- R.P.B. ----- ROAD PLAT BOOK
- O.R./O.R.B. ----- OFFICIAL RECORDS BOOK
- PG./PG(S) ----- PAGE(S)
- NAD ----- NORTH AMERICAN DATUM
- W.M.T. ----- WATER MANAGEMENT TRACT
- O.S.T. ----- OPEN SPACE TRACT
- P.B.C. ----- PALM BEACH COUNTY
- U.E. ----- UTILITY EASEMENT
- D.E. ----- DRAINAGE EASEMENT
- F.M.E. ----- FORCE MAIN EASEMENT
- W.M.E. ----- WATER MAIN EASEMENT
- 12-43-40 ----- SECTION-TOWNSHIP-RANGE
- AC.±/AC± ----- ACRES
- LB ----- LICENSED BUSINESS
- R ----- RADIUS
- L ----- ARC LENGTH
- Δ ----- DELTA ANGLE
- CB ----- CHORD BEARING
- C ----- CHORD
- CL ----- CENTER LINE OF ROAD
- N.T. ----- NON-TANGENT
- N.T.C. ----- NON-TANGENT CURVATURE
- N.T.I. ----- NON-TANGENT INTERSECTION
- P.C. ----- POINT OF CURVATURE
- P.T. ----- POINT OF TANGENCY
- R.C. ----- REVERSE CURVATURE
- R/W ----- RIGHT-OF-WAY
- HOA ----- HOMEOWNERS ASSOCIATION
- S.I.D. ----- SEMINOLE IMPROVEMENT DISTRICT
- PRM ----- PERMANENT REFERENCE MONUMENT
- ----- PERMANENT CONTROL POINT
- ----- FOUND PERMANENT REFERENCE MONUMENT
- ----- SET 4"x4" CONCRETE MONUMENT WITH 2" ALUMINUM DISK STAMPED "PRM LB 7768"

