

STANDARD AND HANDICAP PARKING DETAIL

NTS

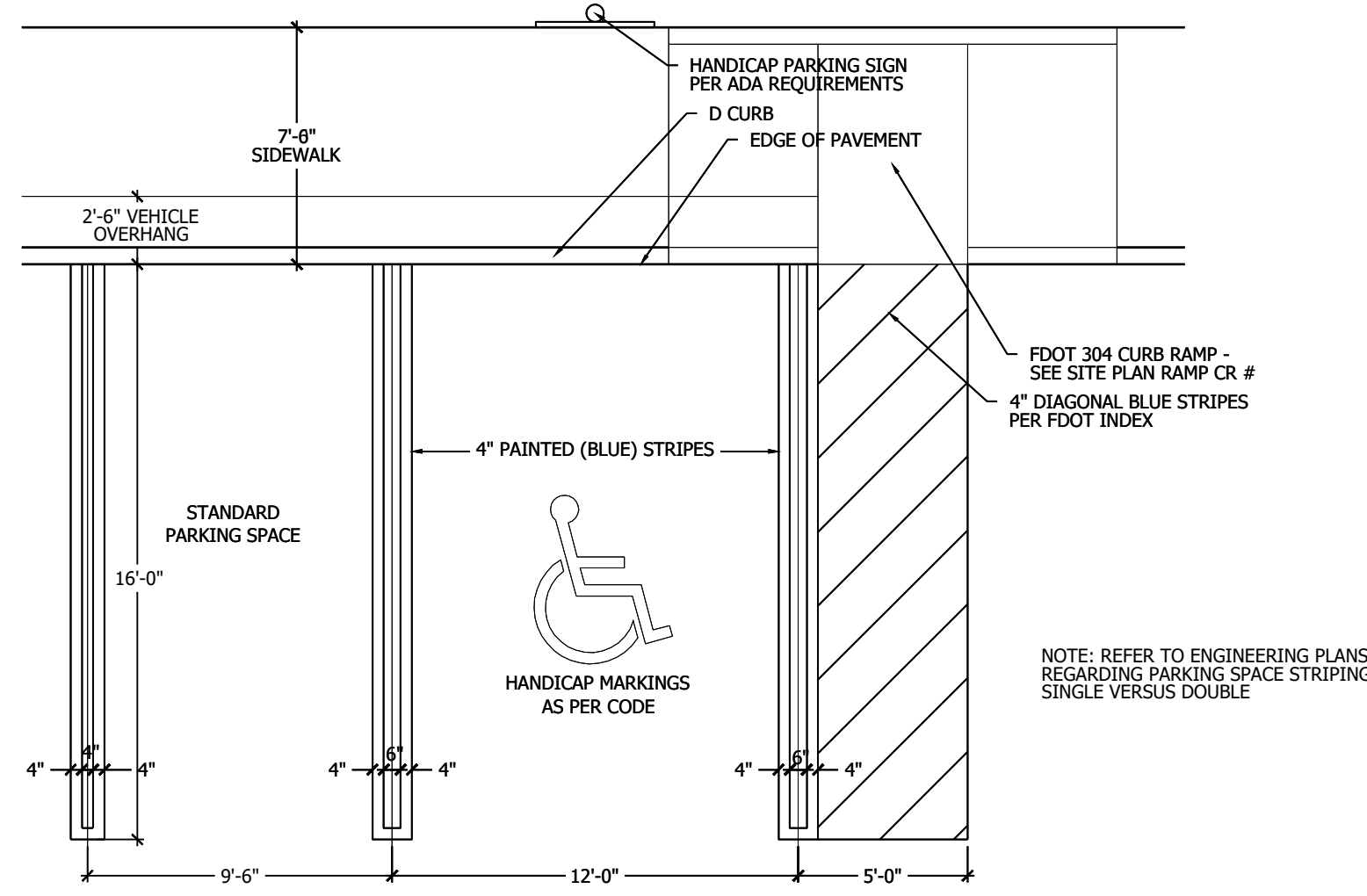

HANDICAP RAMP DETAIL

NTS

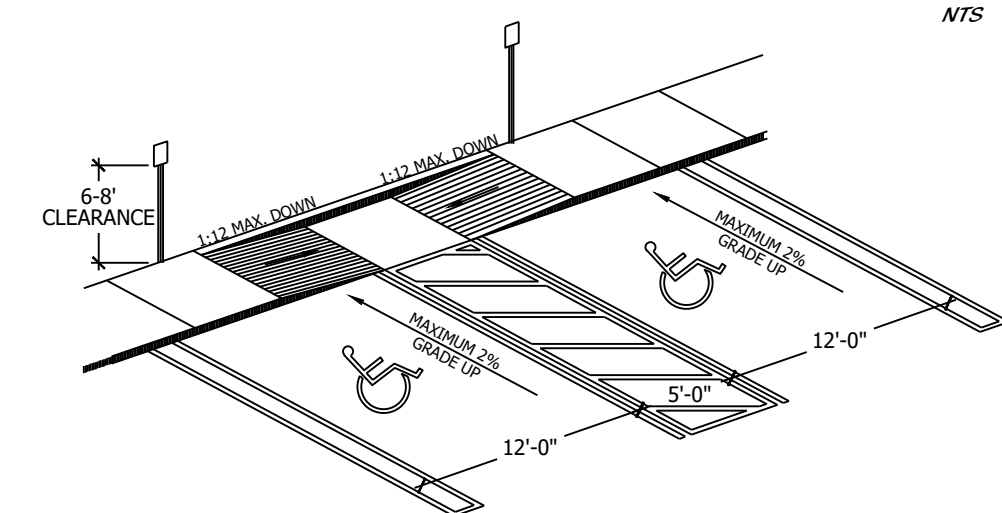

NOTE: IN THIS APPLICATION RAMPS CAN BE SEPARATED AND SIDEWALK CAN BE FLUSH ACROSS ALL HC SPACES
 NOTE: HCR#3-MOD MEANS ONLY 1 RAMP BUILT TO REQUIRED SIDE OF SIDEWALK. OR RAMPS SEP. TO ENDS OF HC SPACES
 NOTE: REFER TO ENGINEERING PLANS REGARDING PARKING SPACE STRIPING SINGLE VERSUS DOUBLE

HANDICAP SIGN DETAIL

NTS

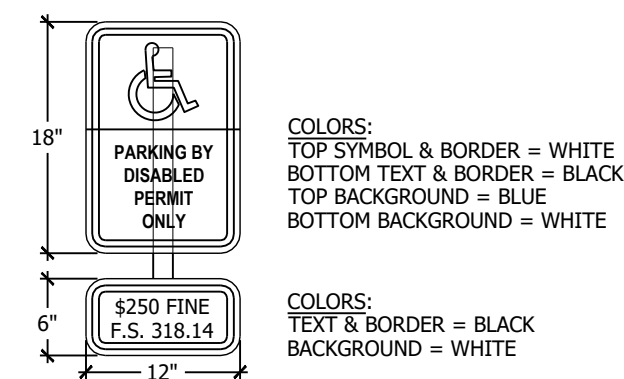

HANDICAP SYMBOL DETAIL

NTS

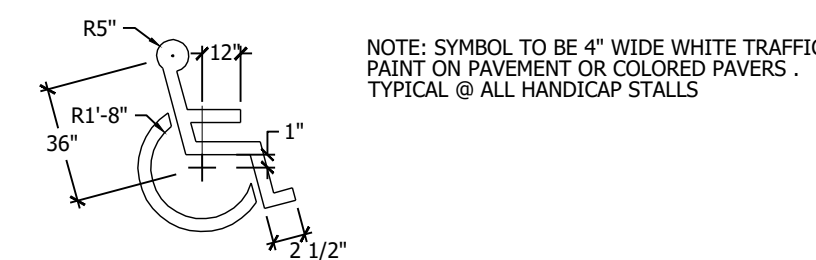

CAR CHARGING STATION

(OR EQUAL)

NTS



WWW.LEVITON.COM
 PRODUCT #Q 1478
 MANUFACTURE: LEVITON
 CHARGING: DUAL
 TYPE: DUAL MOUNT EV SERIES PEDESTAL SYSTEM
 OR APPROVED BY LANDSCAPE ARCHITECT
 INSTALL PER MANUFACTURERS RECOMMENDATIONS

DUMPSTER DETAIL

NTS

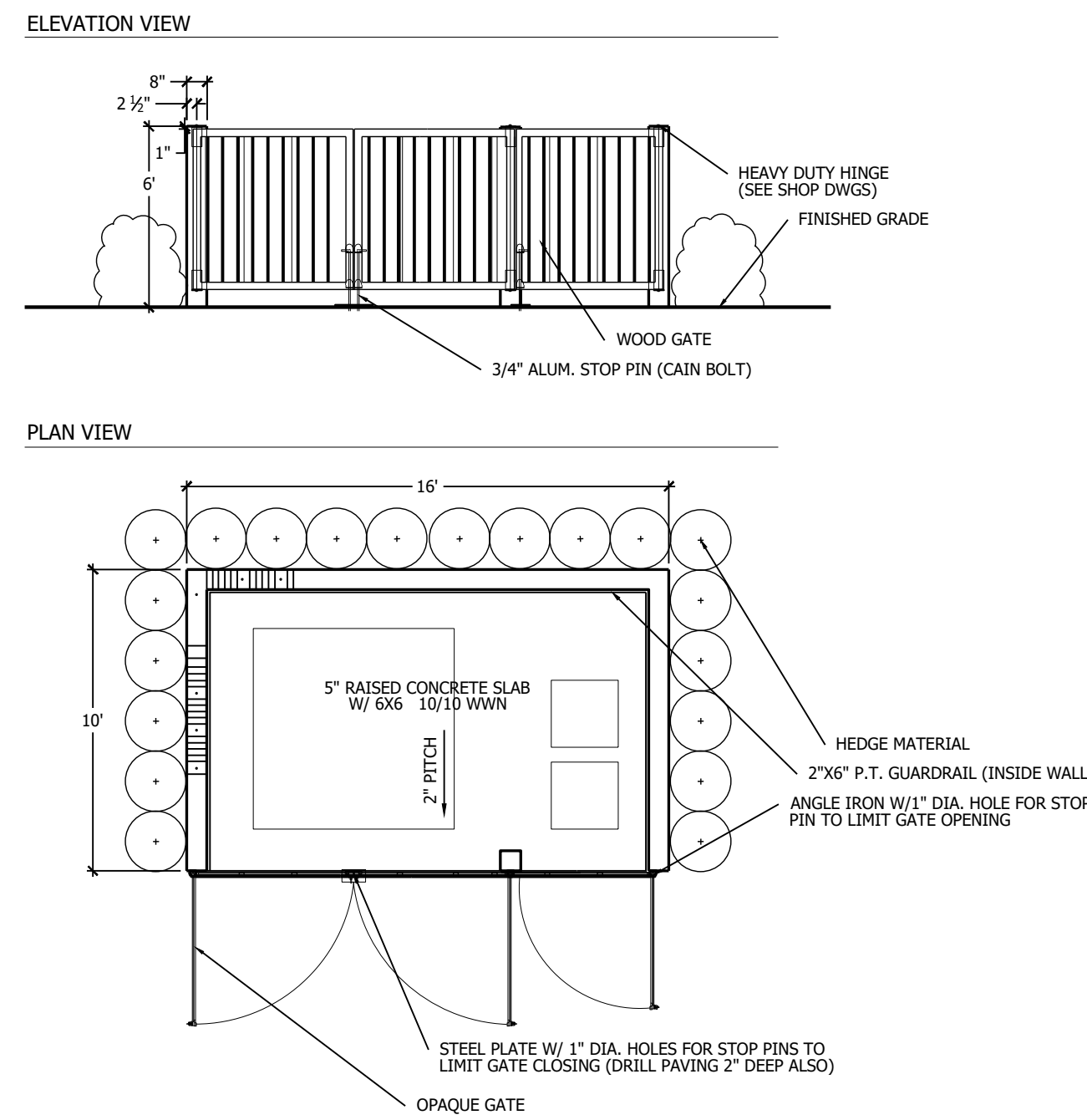

BENCH DETAIL

NTS



WWW.ULINE.COM
 MODEL NO. H-3019
 COURTYARD BENCH WITHOUT BACK 6'
 COLOR - BLACK

BIKE RACK DETAIL (5 SPACES PER RACK)

ULINE

NTS

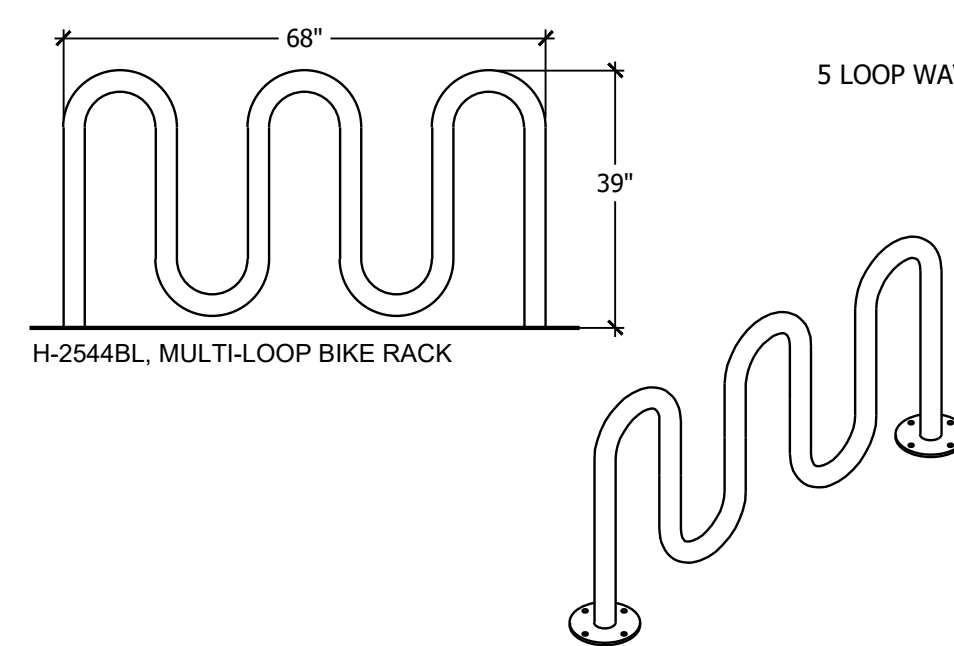

HEAD TO HEAD PARKING DETAIL

NTS

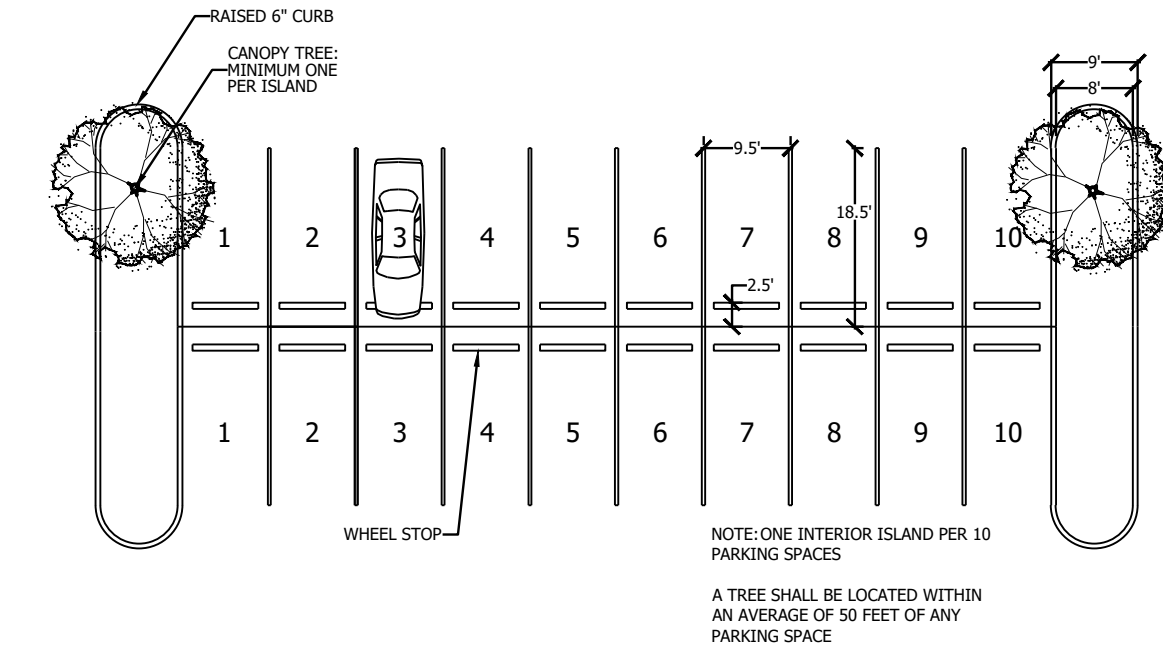

BOLLARD DETAIL

NTS

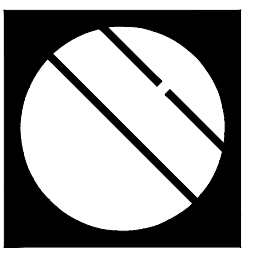
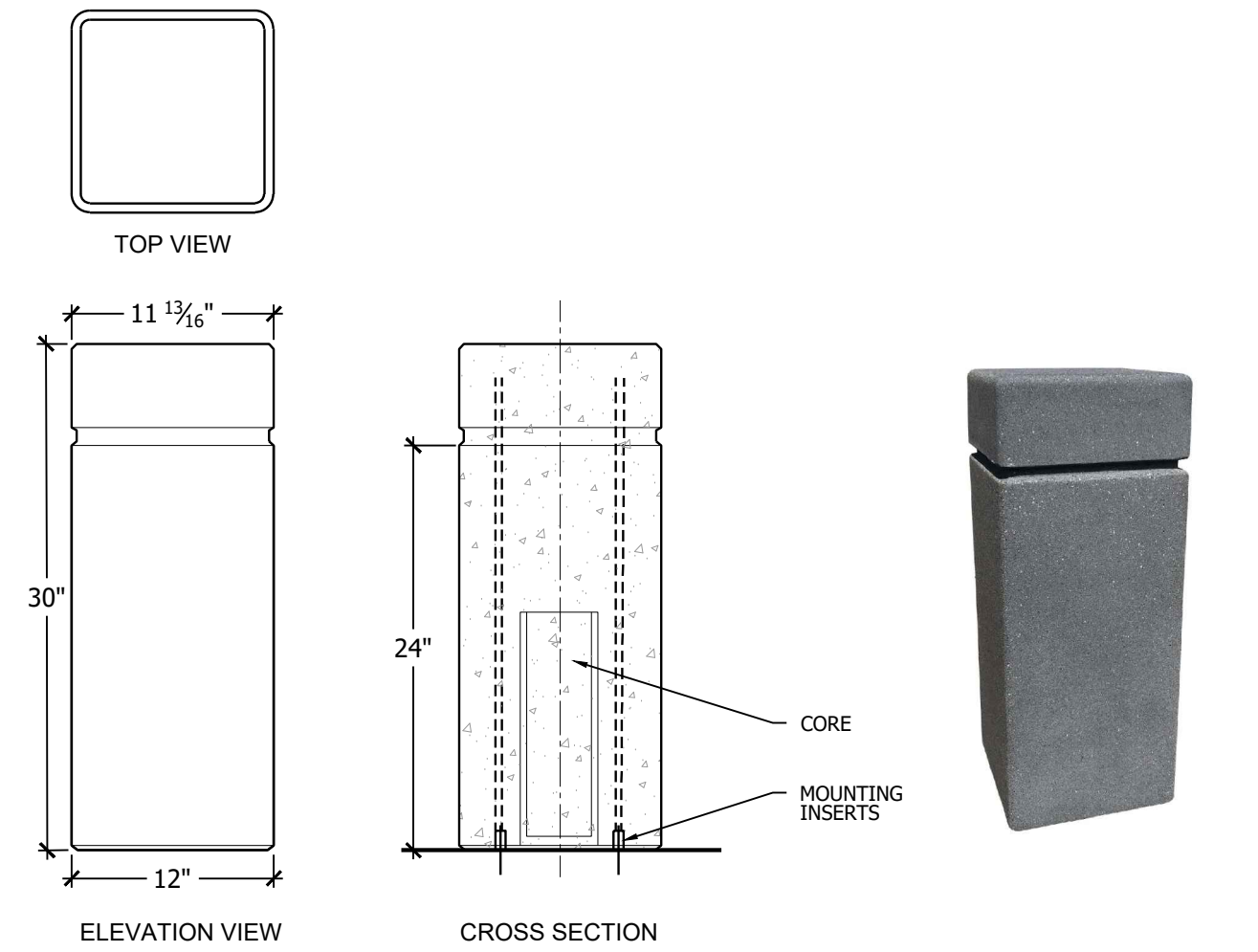

Cotleur & Hearing

Landscape Architects
 Land Planners
 Environmental Consultants
 1934 Commerce Lane
 Suite 1
 Jupiter, Florida 33458
 561.747.6336 · Fax 747.1377
 www.cotleurhearing.com
 Lic# LC-C000239

**MINTO WESTLAKE
 Christ Fellowship-Pod J
 REGULATING PLAN
 City of Westlake, Florida**

DESIGNED	DEH
DRAWN	RS
APPROVED	DEH
JOB NUMBER	19-0202
DATE	09-24-19
REVISIONS	11-08-19
	11-19-19
	03-21-23
	03-28-23
	04-14-23

APPROVAL STAMP

April 14, 2023 9:37:28 a.m.
 Drawing: 190202 REG.OWG