

DUMPSTER DETAIL

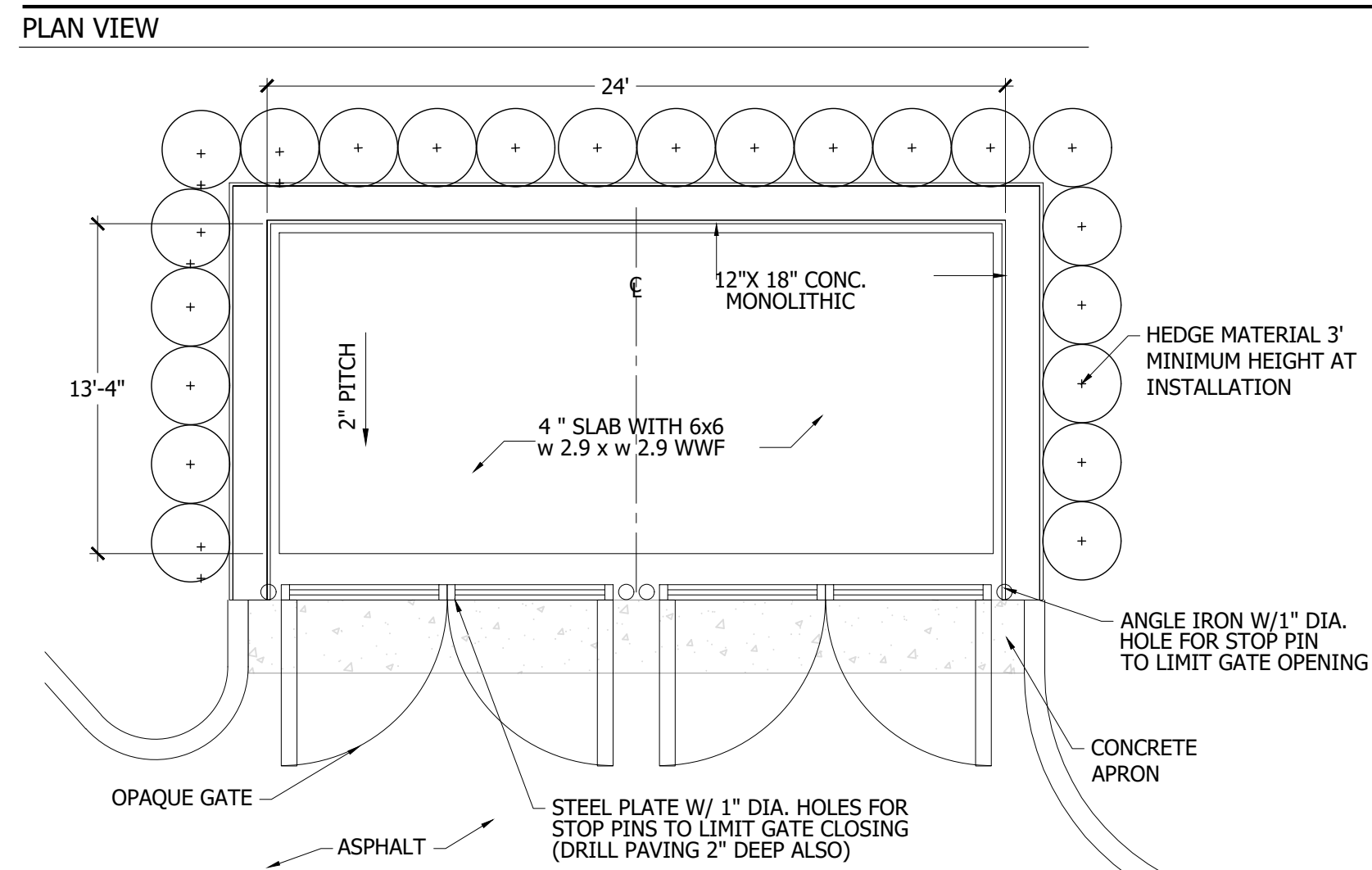

ELEVATION VIEW
NOTE: DUMPSTER MUST BE SCREENED PER SECTION 4.14 (A) OF THE CITY OF WESTLAKE LANDSCAPE CODE

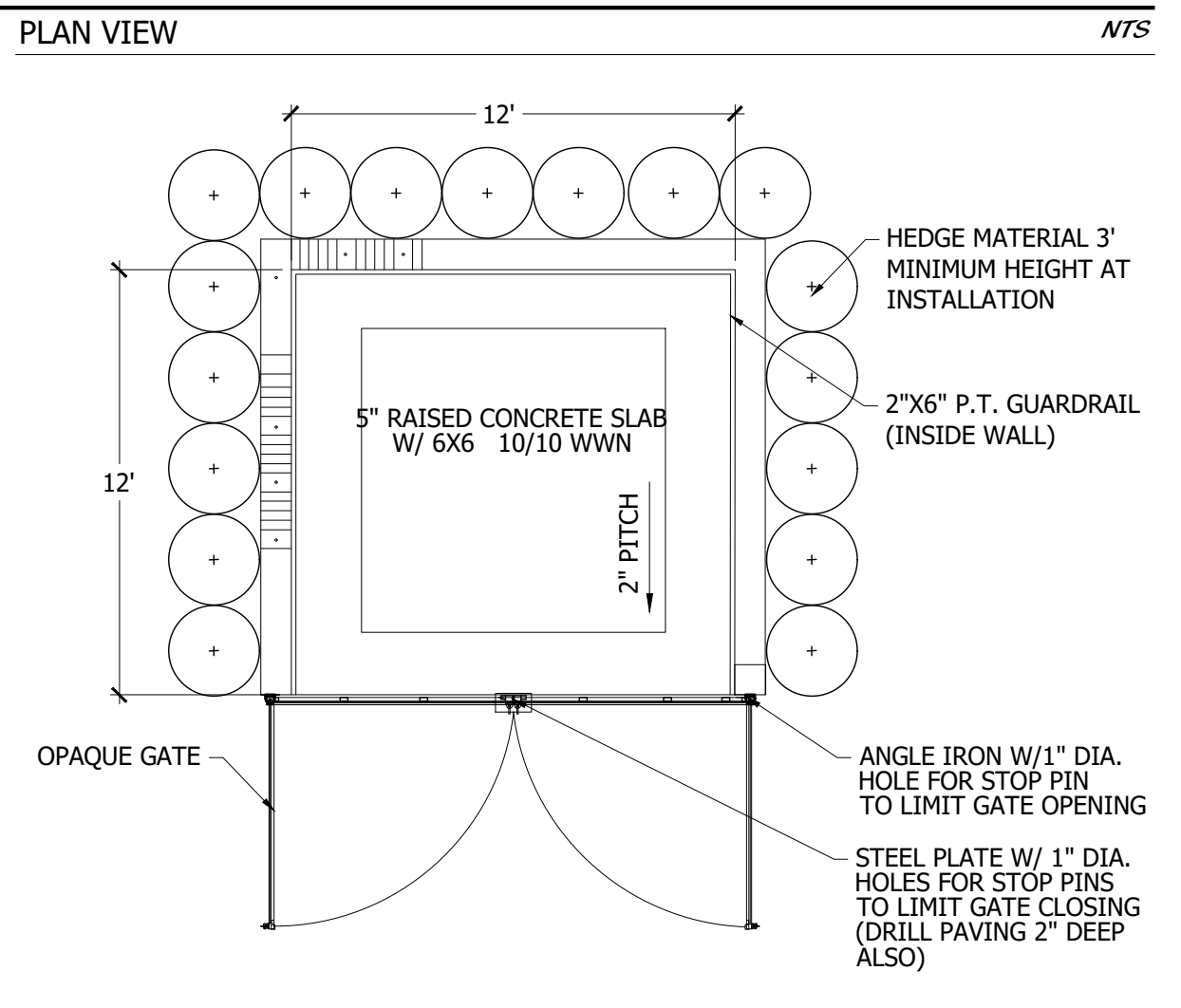
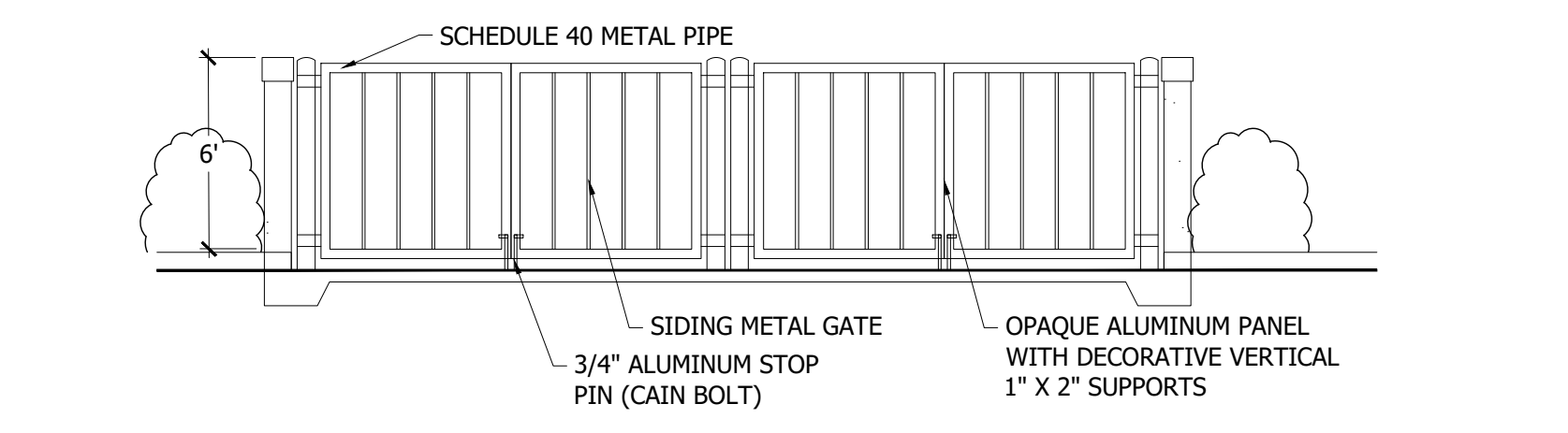

ELEVATION VIEW

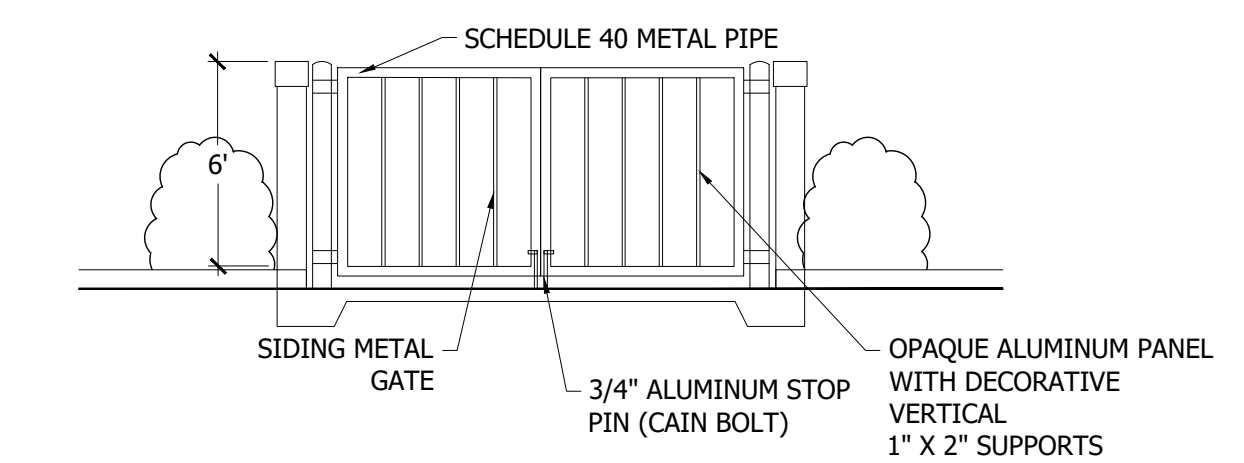

STANDARD AND ADA PARKING DETAIL

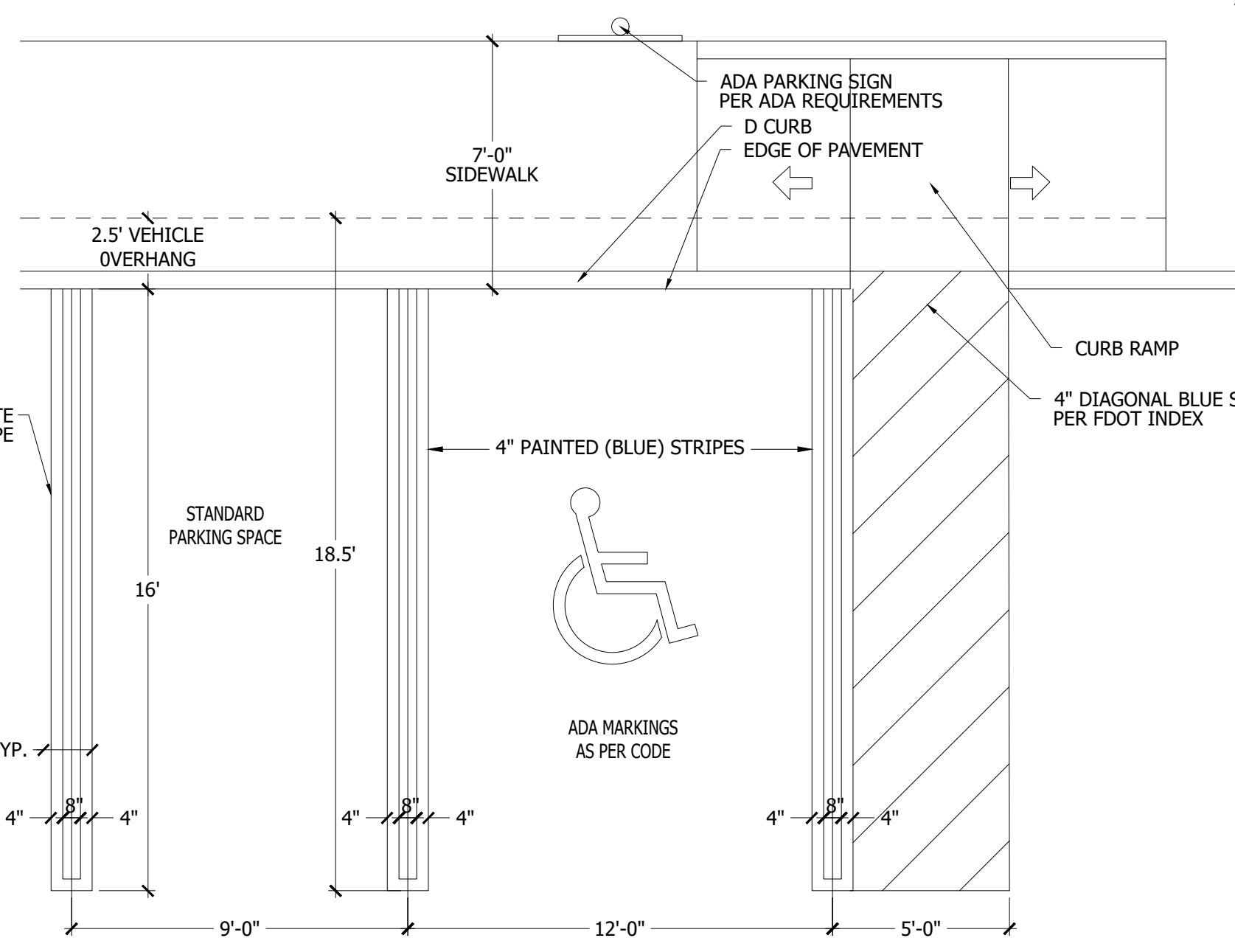

D CURB DETAIL VALLEY CURB DETAIL

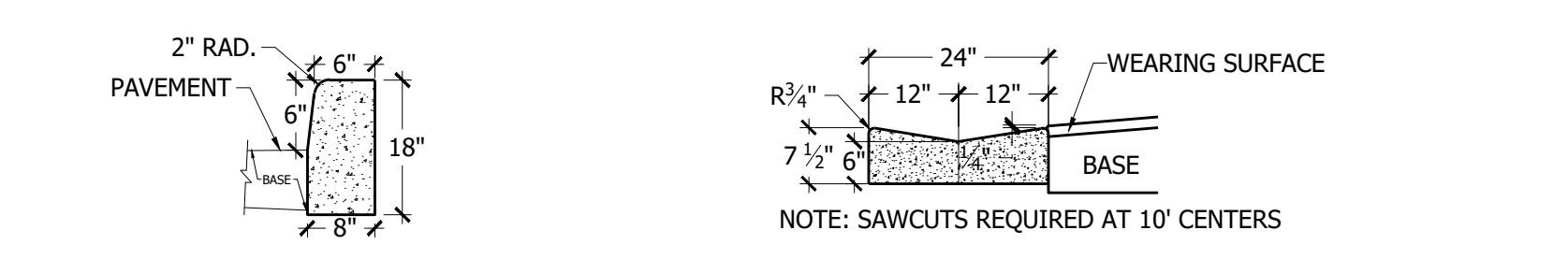

F CURB DETAIL

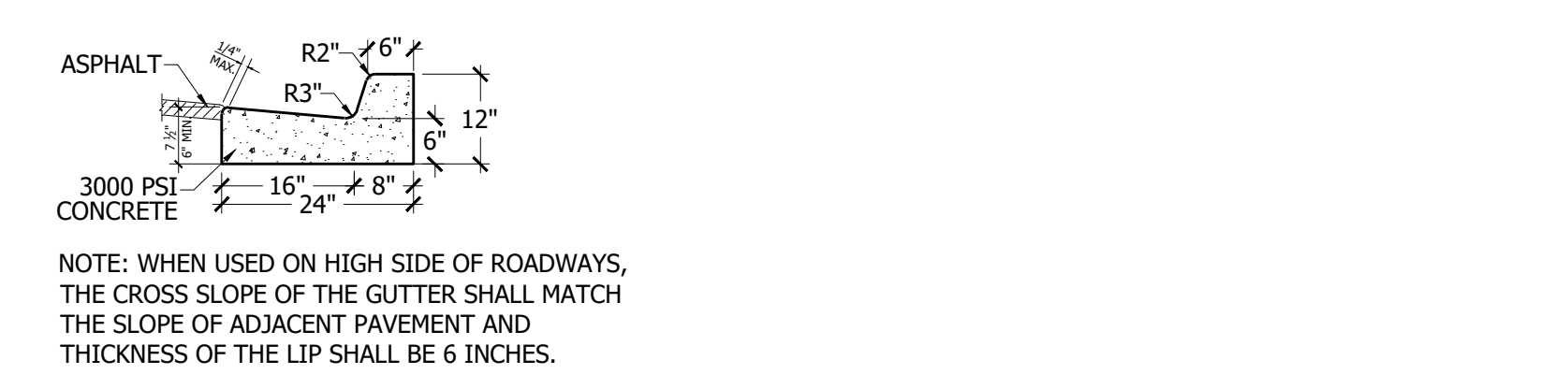

TRASH CAN DETAIL

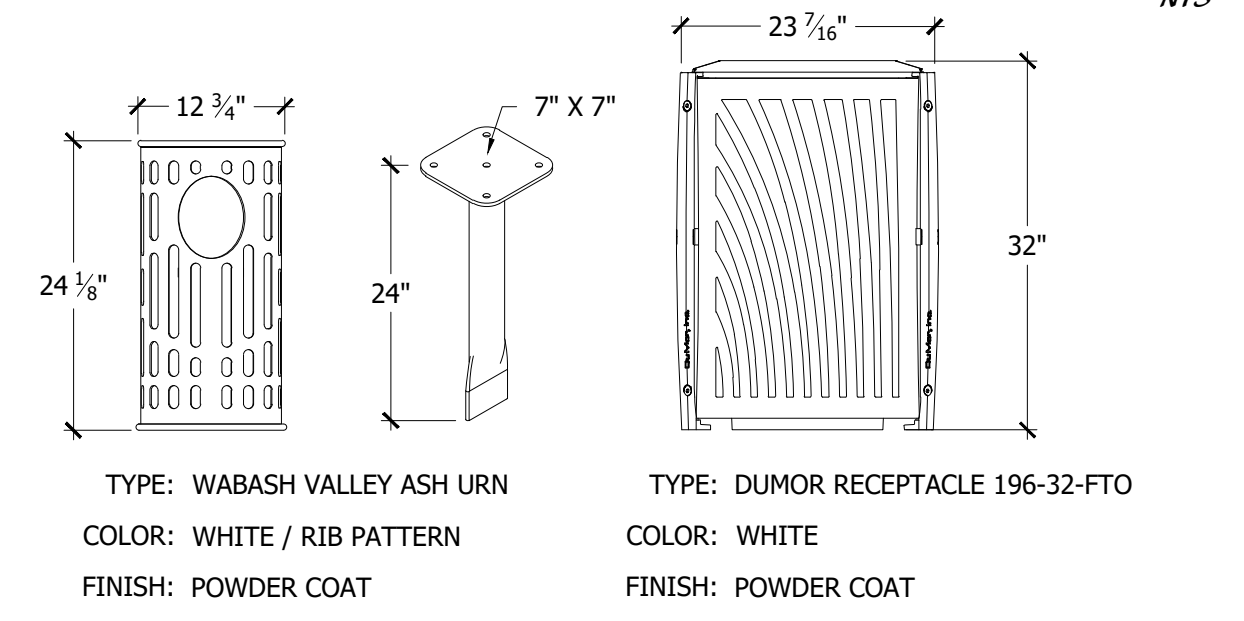

ADA RAMP DETAIL

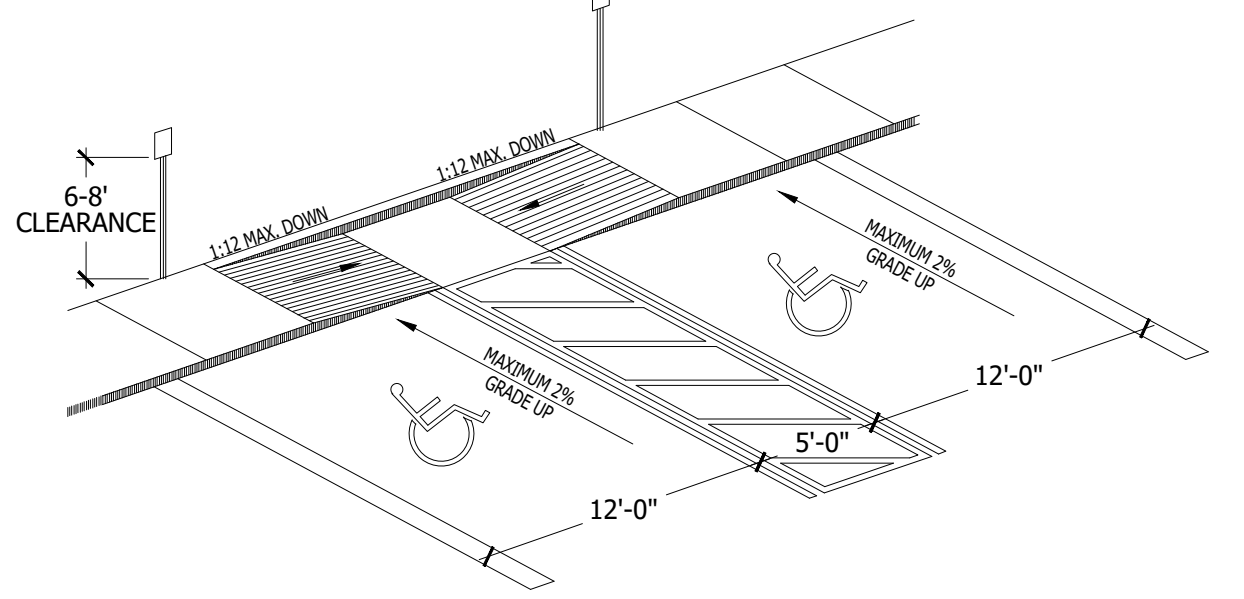

ADA SIGN & SYMBOL DETAIL

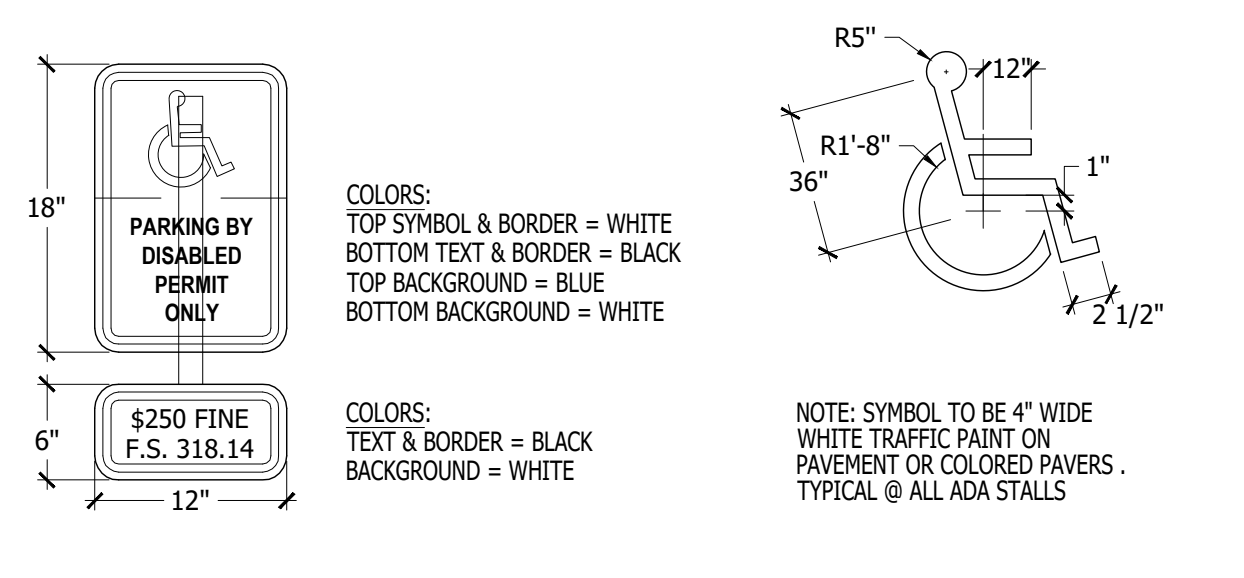

CROSS SECTIONS

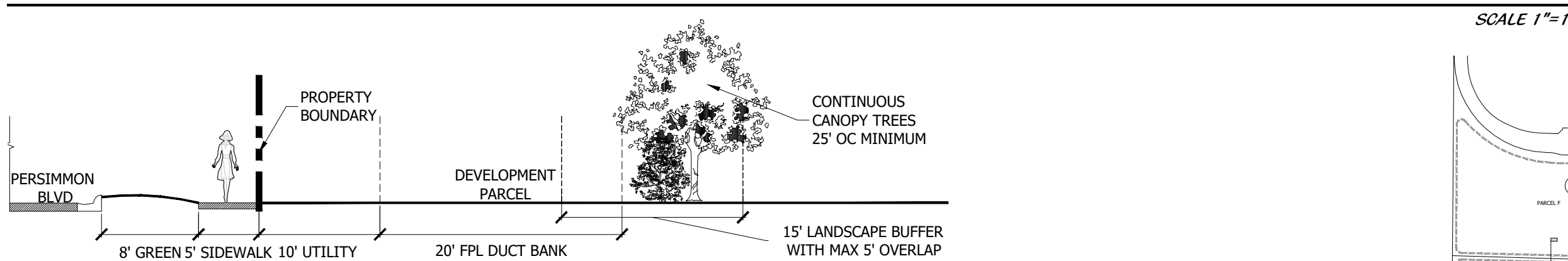

A - NORTH BUFFER

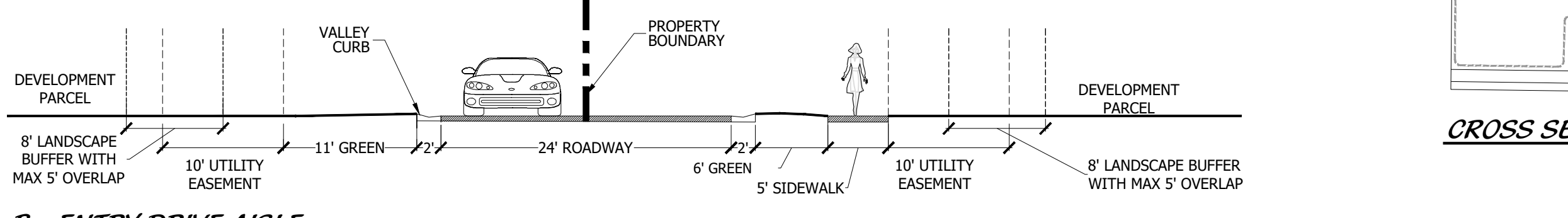

B - ENTRY DRIVE AISLE



C - PARCEL LANDSCAPE BUFFER

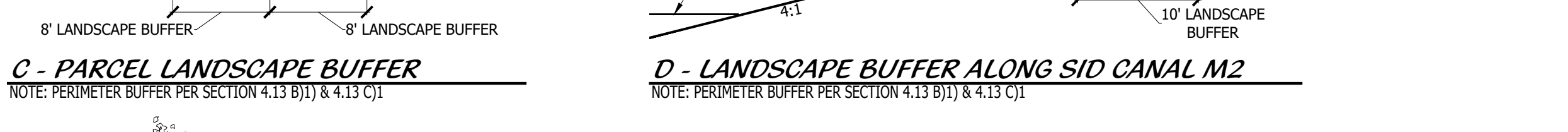

D - LANDSCAPE BUFFER ALONG SID CANAL M2



E - LANDSCAPE BUFFER ALONG SID CANAL D3



BENCH DETAILS

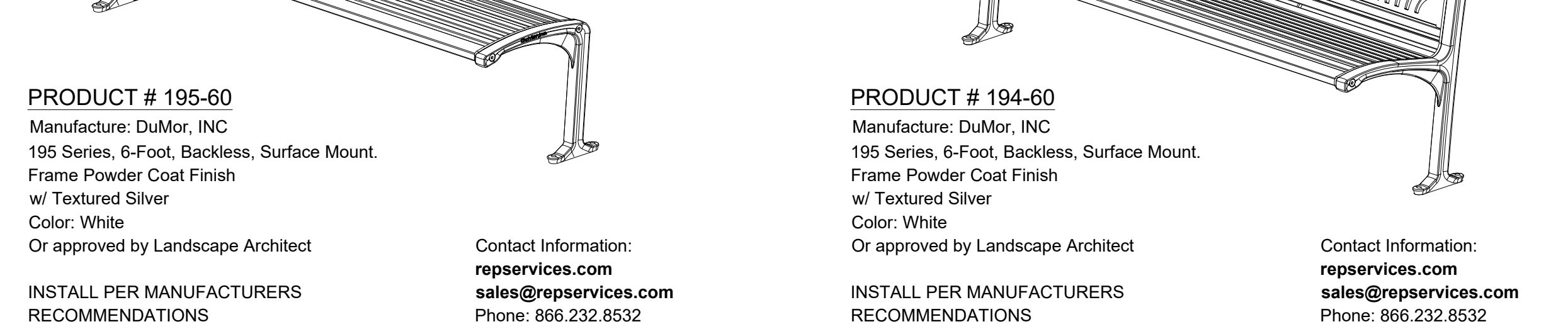

BIKE RACK DETAIL

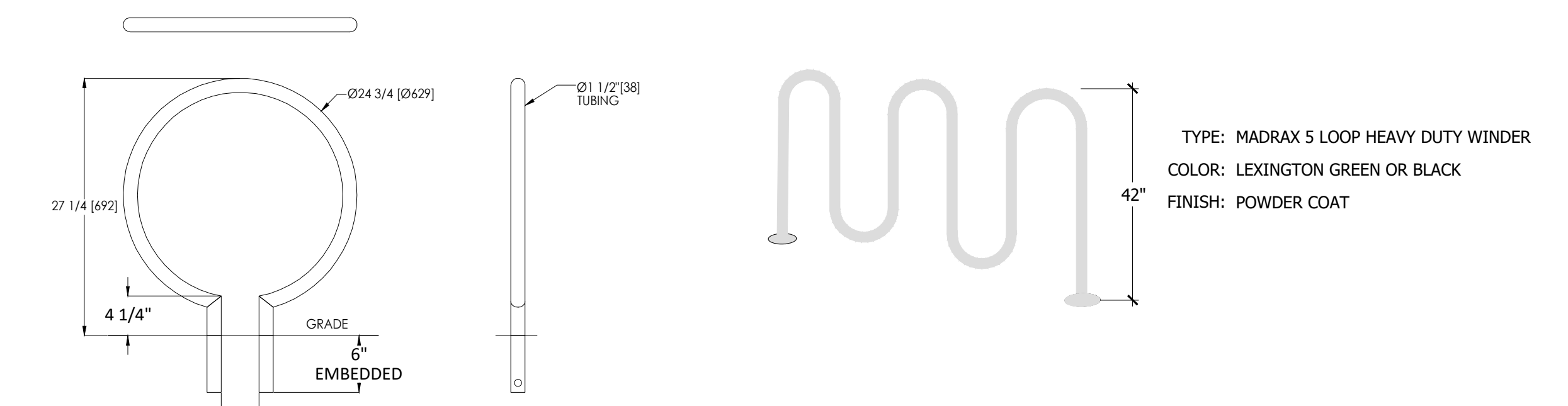

RING BIKE RACK, EMBEDDED (OR EQUAL) landscapeforms®
www.landscapeforms.com Ph: 800.521.2546

Cotleur & Hearing
Landscape Architects
Land Planners
Environmental Consultants
1934 Commerce Lane
Suite 1
Jupiter, Florida 33458
561.747.6336 - Fax 747.1377
www.cotleurhearing.com
Lic# LC-C000239

WESTLAKE LANDINGS

POD H MASTER PLAN
PALM BEACH COUNTY, FL

DESIGNED	DEH
DRAWN	JAE/RNK
APPROVED	DEH
JOB NUMBER	13-0518-60
DATE	03-25-21
REVISIONS	04-12-21
	05-25-21
	06-12-21
	07-15-21
	09-03-21
	10-04-21

November 02, 2021 3:32:48 p.m.
Drawing: 13-0518.60 SD.DWG

SHEET 2 OF 2

© COTLEUR & HEARING, INC.
These drawings are the property of the architect and are not to be used for extensions or on other projects except by agreement in writing with the architect. Immediately report any discrepancies to the architect.

Site Details