

PEDESTRIAN ASSEMBLY:

FIXTURE/ARM: DS6S-PLED-XX-XXLED-XXXMA-XXK-UNV-PT/XPD/STD FINISH
 POLE / SHAFT: 7-1070-12'-PT27-GFIIU-RAL9005T

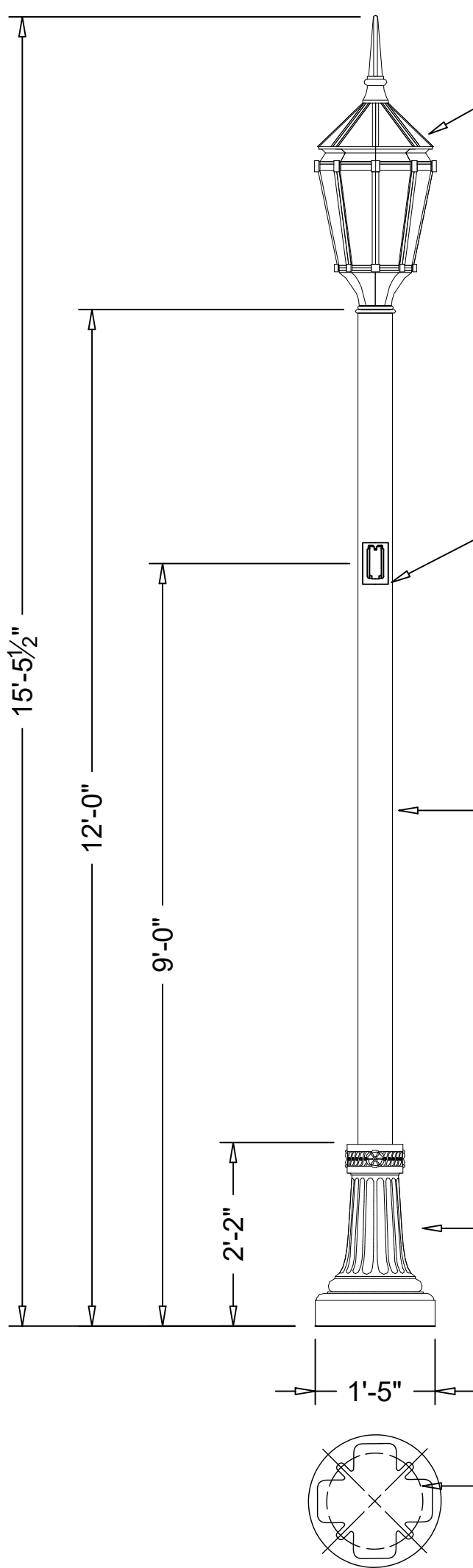

356 ALLOY CAST ALUMINUM FIXTURE CAGE AND HOUSING, HIGH IMPACT FROSTED ACRYLIC DIFFUSING LENSES PROVIDED WITH DURABLE CORROSION RESISTANT CAST ALUMINUM HOUSING. TOP IS HINGED FOR ACCESS. LUMINAIRE BASE HAS 3/4\"/>

- PLED-III-20LED-525MA-40K
- 55 WATT
 - 5805 LUMENS
 - 4000K COLOR TEMPERATURE
 - TYPE III DISTRIBUTION

15 AMP GFI DUPLEX RECEPTACLE WITH WEATHERPROOF IN USE COVER

ROUND EXTRUDED STRAIGHT SMOOTH POLE SHAFT, 6063 ALLOY ALUMINUM, 5\"/>

ELECTROSTATICALLY APPLIED TGIC POLYESTER POWDER COAT ON SUBSTRATE PREPARED WITH 20 PSI POWER WASH AT 140°F. FOUR STEP MEDIA BLAST AND IRON PHOSPHATE PRETREATMENT FOR PROTECTION AND PAINT ADHESION. 400°F BAKE FOR MAXIMUM HARDNESS AND DURABILITY. FINISH TO BE TEXTURED BLACK (RAL 9005T)

ONE PIECE CORROSION RESISTANT, DURABLE CAST ALUMINUM CONSTRUCTION. MINIMUM .210 WALL THICKNESS. BASE CONSISTS OF A SMOOTH, TAPERED BOTTOM SECTION, AND A HIGHLY DETAILED, DECORATIVE FLUTED SECTION, A DECORATIVE CAST ALUMINUM COLLAR AND A FLUTED HAND HOLE COVER CONTOURED TO BASE DESIGN. HAND HOLE COVER SUPPLIED WITH TAMPER RESISTANT HARDWARE. GROUNDING LUG PROVIDED INSIDE BASE OPPOSITE HAND HOLE.

A 3/4\"/>

12\"/>



No.	Revision/Issue	Date

Project Name:
Watertown WI

Part No:

Drawn By: S.S.	Sheet:
Date: 1/15/26	SS011526B
Scale: NTS	