

WALLER COUNTY

Danny R. Rothe, CCCA
County Facilities Director and Construction Manager



MEMORANDUM

To: Honorable Commissioners' Court

Item: Third Floor Courtroom Pews

Date: April 29, 2026

Background

Judge/Commissioners

3rd Floor Courtroom Pews. Same as Commissioners Court, except a different color fabric.

Costs:

- Total - \$22,387.00

Source of Funds:

- Third Floor Soft Cost #40 (Under \$28,000 budget)

Staff Recommendation

Please approve Quotes from Imperial Woodworks.

Danny R. Rothe
Waller County Construction Manager

d.rothe@wallercounty.us



Imperial Woodworks, Inc.
P.O. Box 7835
Waco, TX 76714

11/24/2025

Re: Waller County Courthouse - 3rd Floor Pews

Dear: Whitney Womble

Imperial Woodworks, Inc. appreciates the opportunity to submit this proposal for courtroom pews to be used in the Waller County Courthouse.

Total Base Bid, delivered and with installation: \$ 22,387.00

#28,000 #40
SOFT COST

The base bid includes the following:

10 courtroom pews totaling 166' per plan

Delivery and installation of new pews by Imperial Woodworks, Inc.

- Materials:** First grade, plain sliced Red Oak veneers and FAS solids
- Bench Body:** 940 All wood pew back
- Bench Seat:** 984 Foam seat with 4" contoured foam
- Bench End:** 24SE With rout
- Supports:** All supports will be evenly spaced on each bench with the distance between supports never exceeding 5'6". Supports made of plywood core with solid Red Oak. All supports 1 1/4" thick.
- Finish:** Imperial uses a conversion varnish finish for our furniture. This finish is MAINTENANCE FREE: No Mandatory polishing or other custodial care such as waxing is ever required as a condition of warranty. Only dusting with a barely damp cloth is recommended.
- Anchors:** Double concealed anchors at each end of the pew are standard. All concrete anchors shall be "Chicago" lead expansion bolts. Single anchors are not acceptable.
- Wood Color:** Owner Specified
- Fabric Color:** Choice of manufacturer's standard options
- Terms of Payment:** County terms of payment

Lead Time: 90-120 days from receipt of order with all details final

Our proposal includes delivery and installation as qualified below. Applicable sales taxes, if any, would be in addition to the prices quoted. Delivery is calculated using our tractor and trailer. Off loading of the disassembled benches and placement in the building is included using our non-union labor. Installation of the benches is included, using our non-union labor. Any costs for union labor, union dues, memberships, etc., are not part of this proposal.

Our proposal is subject to review in 30 days. Our price is predicated on delivery of the furniture within 12 months from our receipt of the order, with all details complete.

We look forward to being of service to you and the church. We know you will be completely satisfied with the **QUALITY, COMFORT, AND CRAFTSMANSHIP** of our product and the **INTEGRITY** of our people.

Wesley Abrahams
Project Manager at Imperial Woodworks, Inc.
Direct: (254) 537-9331 Office: (800) 234-6624 ext. 219
P.O. Box 7835 | Waco, TX 76714
www.pews.com

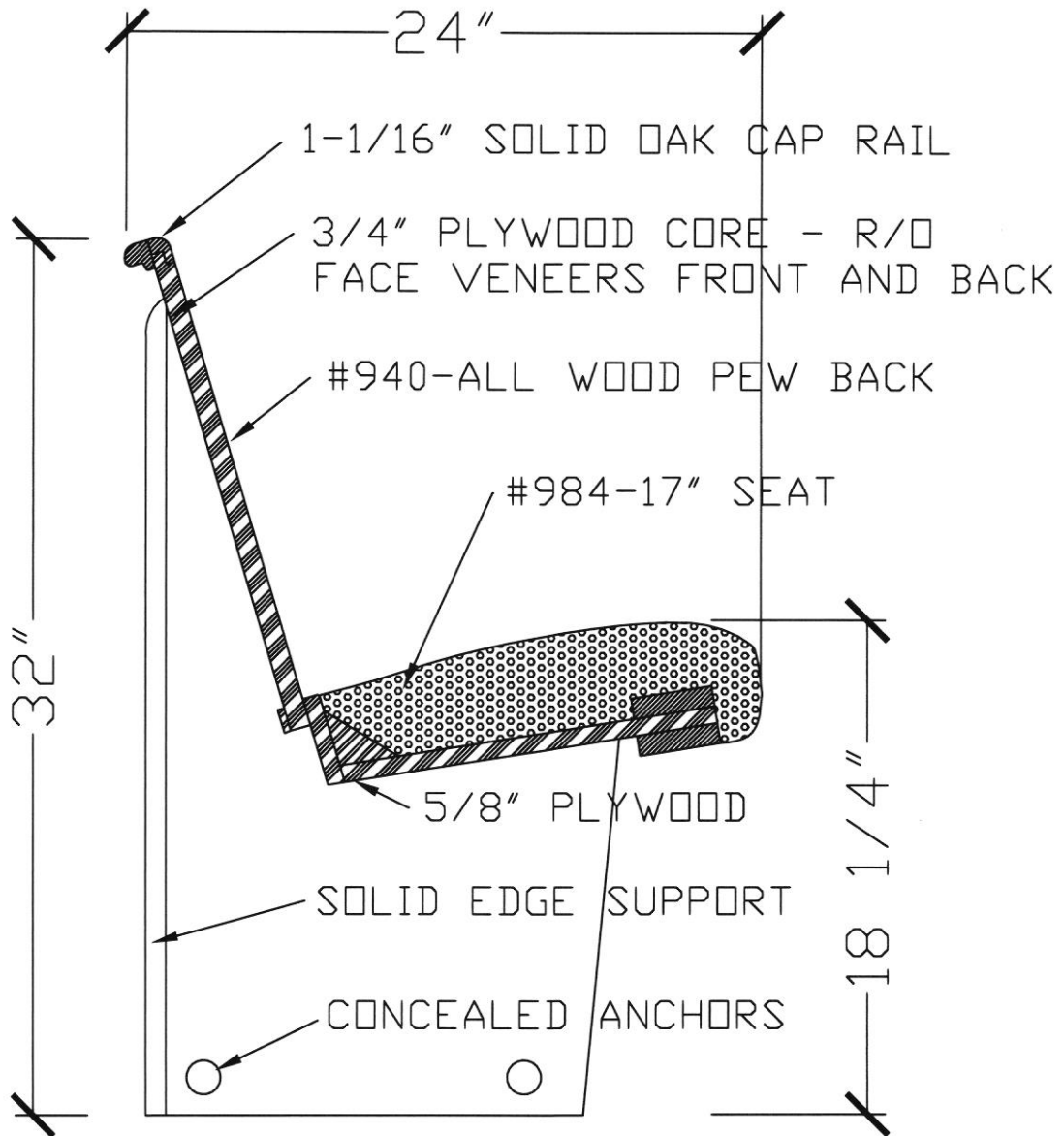

#940-984 PEW BODY SECTION

IMPERIAL WOODWORKS, INC.
WACO, TEXAS

SOLID RED OAK BAND
WITH #5 EDGE MOLD

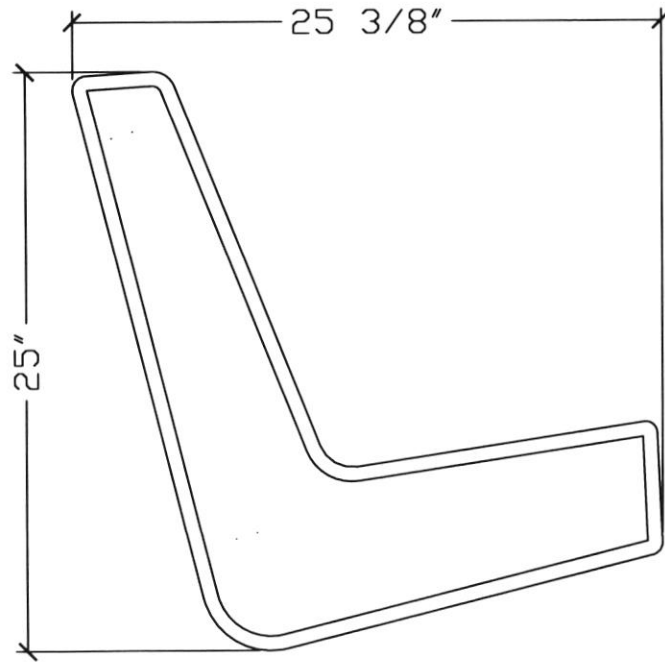

 7201 MARS DR WACO, TX 76712 (254) 741-0606 (800) 234-6624 www.pews.com		SITE	
		DWG TITLE PEW END, CANTILEVER #5 SOLID EDGE MOLD	
BY	DLW	DATE	10/24/19
CHK		DATE	
CUST APP		DATE	
JOB NO.		DWG NO.	REV
A		24-SE	-
SCALE	1/8	FILE NAME	SHEET 1 OF 1
		24-S.dwg	

REV	DESCRIPTION	BY	DATE