

**PLANNING COMMISSION RESOLUTION 2026-06
A RESOLUTION OF THE TOWN OF TRUCKEE PLANNING COMMISSION
APPROVING APPLICATION NO. 2025-00000150
(THE VILLAGE AT GRAY'S CROSSING PROJECT AMENDMENT #3)**

EXHIBIT "H"

TENTATIVE MAP (WITH RECORDED ITEMS REMOVED)

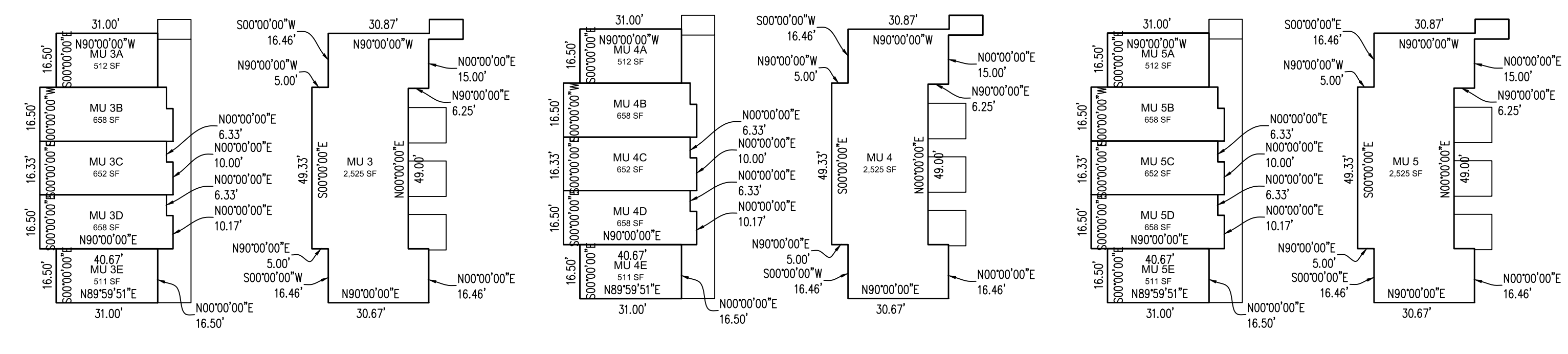

BUILDING MU 3
LOT 3
1" = 30'

BUILDING MU 4
LOT 2
1" = 30'

BUILDING MU 5
LOT 1
1" = 30'

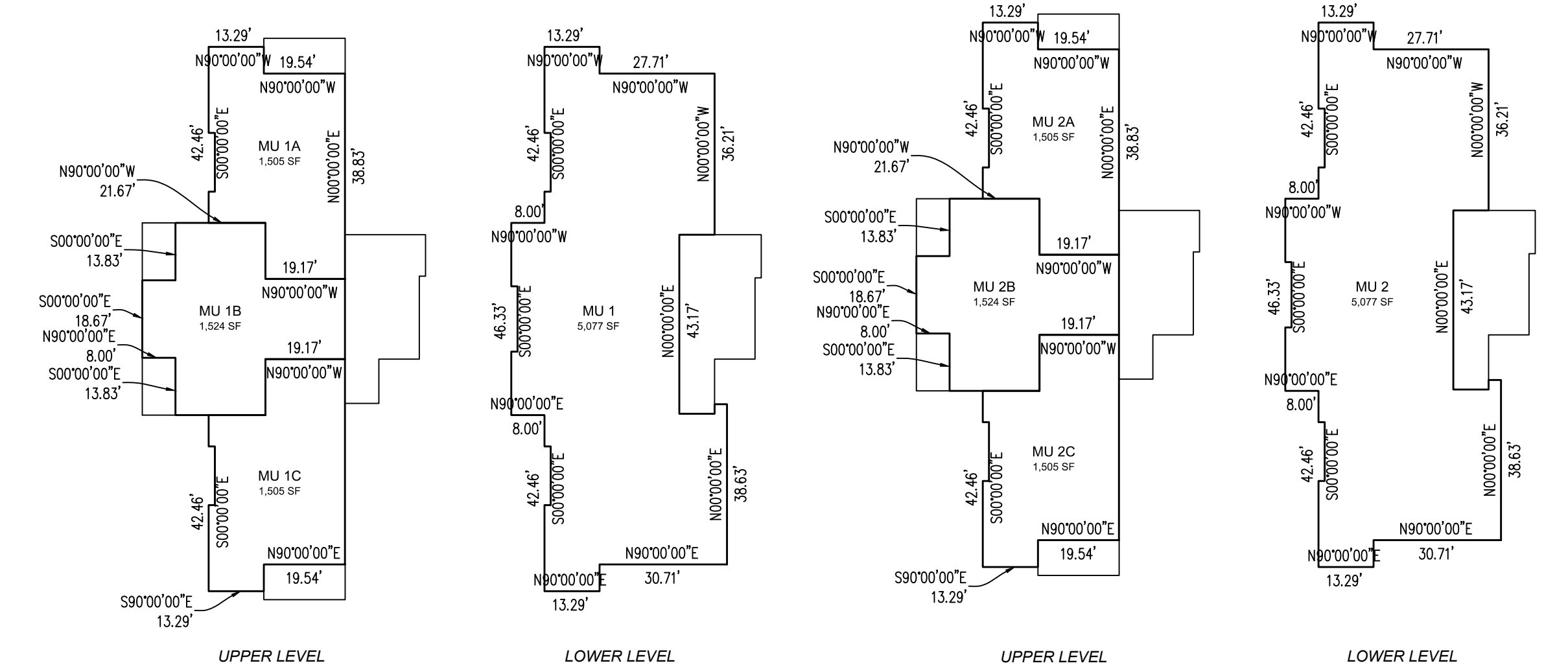

BUILDING MU 1
LOT 6
1" = 30'

BUILDING MU 2
LOT 5
1" = 30'

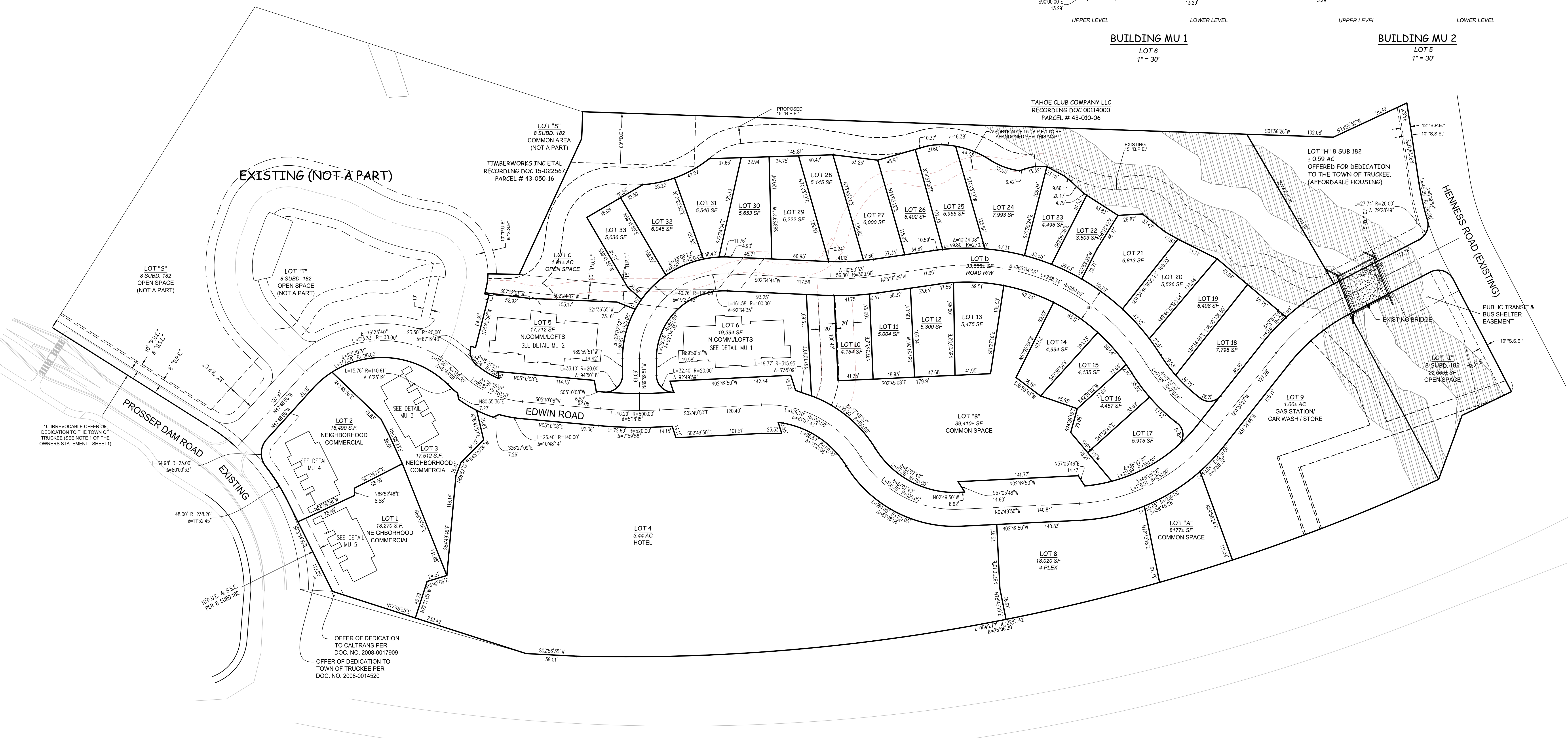

TAHOE CLUB COMPANY LLC
RECORDING DOC 00114000
PARCEL # 43-010-06

EXISTING (NOT A PART)

HENNESS ROAD (EXISTING)

EXISTING BRIDGE

PUBLIC TRANSIT & BUS SHELTER EASEMENT

LOT 11
8 SUBD. 182
22,684 SF
OPEN SPACE

LOT 9
1.024 AC
GAS STATION/
CAR WASH / STORE

LOT 18
7,788 SF

LOT 19
6,408 SF

LOT 20
5,526 SF

LOT 21
6,813 SF

LOT 22
3,603 SF

LOT 23
4,495 SF

LOT 24
7,993 SF

LOT 25
5,955 SF

LOT 26
6,402 SF

LOT 27
6,000 SF

LOT 28
5,145 SF

LOT 29
6,222 SF

LOT 30
5,653 SF

LOT 31
5,540 SF

LOT 32
6,045 SF

LOT 33
5,036 SF

LOT C
1.81 AC
OPEN SPACE

LOT 5
17,712 SF
N. COMM. LOFTS
SEE DETAIL MU 2

LOT 6
19,394 SF
N. COMM. LOFTS
SEE DETAIL MU 1

LOT 10
4,754 SF

LOT 11
6,004 SF

LOT 12
6,300 SF

LOT 13
5,475 SF

LOT 14
4,994 SF

LOT 15
4,735 SF

LOT 16
4,457 SF

LOT 17
5,915 SF

LOT 8
18,020 SF
4-PLEX

LOT A
COMMON SPACE

LOT B
29,415 SF
COMMON SPACE

LOT D
33,559 SF
ROAD ROW

LOT E
1.81 AC
OPEN SPACE

LOT F
1.81 AC
OPEN SPACE

LOT G
1.81 AC
OPEN SPACE

LOT H
8 SUBD. 182
± 0.59 AC
OFFERED FOR DEDICATION
TO THE TOWN OF TRUCKEE
(AFFORDABLE HOUSING)

LOT I
8 SUBD. 182
± 0.59 AC
OFFERED FOR DEDICATION
TO THE TOWN OF TRUCKEE
(AFFORDABLE HOUSING)

LOT J
8 SUBD. 182
± 0.59 AC
OFFERED FOR DEDICATION
TO THE TOWN OF TRUCKEE
(AFFORDABLE HOUSING)

LOT K
8 SUBD. 182
± 0.59 AC
OFFERED FOR DEDICATION
TO THE TOWN OF TRUCKEE
(AFFORDABLE HOUSING)

LOT L
8 SUBD. 182
± 0.59 AC
OFFERED FOR DEDICATION
TO THE TOWN OF TRUCKEE
(AFFORDABLE HOUSING)

LOT M
8 SUBD. 182
± 0.59 AC
OFFERED FOR DEDICATION
TO THE TOWN OF TRUCKEE
(AFFORDABLE HOUSING)

LOT N
8 SUBD. 182
± 0.59 AC
OFFERED FOR DEDICATION
TO THE TOWN OF TRUCKEE
(AFFORDABLE HOUSING)

LOT O
8 SUBD. 182
± 0.59 AC
OFFERED FOR DEDICATION
TO THE TOWN OF TRUCKEE
(AFFORDABLE HOUSING)

LOT P
8 SUBD. 182
± 0.59 AC
OFFERED FOR DEDICATION
TO THE TOWN OF TRUCKEE
(AFFORDABLE HOUSING)

LOT Q
8 SUBD. 182
± 0.59 AC
OFFERED FOR DEDICATION
TO THE TOWN OF TRUCKEE
(AFFORDABLE HOUSING)

LOT R
8 SUBD. 182
± 0.59 AC
OFFERED FOR DEDICATION
TO THE TOWN OF TRUCKEE
(AFFORDABLE HOUSING)

LOT S
8 SUBD. 182
± 0.59 AC
OFFERED FOR DEDICATION
TO THE TOWN OF TRUCKEE
(AFFORDABLE HOUSING)

LOT T
8 SUBD. 182
± 0.59 AC
OFFERED FOR DEDICATION
TO THE TOWN OF TRUCKEE
(AFFORDABLE HOUSING)

LOT U
8 SUBD. 182
± 0.59 AC
OFFERED FOR DEDICATION
TO THE TOWN OF TRUCKEE
(AFFORDABLE HOUSING)

LOT V
8 SUBD. 182
± 0.59 AC
OFFERED FOR DEDICATION
TO THE TOWN OF TRUCKEE
(AFFORDABLE HOUSING)

LOT W
8 SUBD. 182
± 0.59 AC
OFFERED FOR DEDICATION
TO THE TOWN OF TRUCKEE
(AFFORDABLE HOUSING)

LOT X
8 SUBD. 182
± 0.59 AC
OFFERED FOR DEDICATION
TO THE TOWN OF TRUCKEE
(AFFORDABLE HOUSING)

LOT Y
8 SUBD. 182
± 0.59 AC
OFFERED FOR DEDICATION
TO THE TOWN OF TRUCKEE
(AFFORDABLE HOUSING)

LOT Z
8 SUBD. 182
± 0.59 AC
OFFERED FOR DEDICATION
TO THE TOWN OF TRUCKEE
(AFFORDABLE HOUSING)

LOT AA
8 SUBD. 182
± 0.59 AC
OFFERED FOR DEDICATION
TO THE TOWN OF TRUCKEE
(AFFORDABLE HOUSING)

LOT AB
8 SUBD. 182
± 0.59 AC
OFFERED FOR DEDICATION
TO THE TOWN OF TRUCKEE
(AFFORDABLE HOUSING)

LOT AC
8 SUBD. 182
± 0.59 AC
OFFERED FOR DEDICATION
TO THE TOWN OF TRUCKEE
(AFFORDABLE HOUSING)

LOT AD
8 SUBD. 182
± 0.59 AC
OFFERED FOR DEDICATION
TO THE TOWN OF TRUCKEE
(AFFORDABLE HOUSING)

LOT AE
8 SUBD. 182
± 0.59 AC
OFFERED FOR DEDICATION
TO THE TOWN OF TRUCKEE
(AFFORDABLE HOUSING)

LOT AF
8 SUBD. 182
± 0.59 AC
OFFERED FOR DEDICATION
TO THE TOWN OF TRUCKEE
(AFFORDABLE HOUSING)

LOT AG
8 SUBD. 182
± 0.59 AC
OFFERED FOR DEDICATION
TO THE TOWN OF TRUCKEE
(AFFORDABLE HOUSING)

LOT AH
8 SUBD. 182
± 0.59 AC
OFFERED FOR DEDICATION
TO THE TOWN OF TRUCKEE
(AFFORDABLE HOUSING)

LOT AI
8 SUBD. 182
± 0.59 AC
OFFERED FOR DEDICATION
TO THE TOWN OF TRUCKEE
(AFFORDABLE HOUSING)

LOT AJ
8 SUBD. 182
± 0.59 AC
OFFERED FOR DEDICATION
TO THE TOWN OF TRUCKEE
(AFFORDABLE HOUSING)

LOT AK
8 SUBD. 182
± 0.59 AC
OFFERED FOR DEDICATION
TO THE TOWN OF TRUCKEE
(AFFORDABLE HOUSING)

LOT AL
8 SUBD. 182
± 0.59 AC
OFFERED FOR DEDICATION
TO THE TOWN OF TRUCKEE
(AFFORDABLE HOUSING)

LOT AM
8 SUBD. 182
± 0.59 AC
OFFERED FOR DEDICATION
TO THE TOWN OF TRUCKEE
(AFFORDABLE HOUSING)

LOT AN
8 SUBD. 182
± 0.59 AC
OFFERED FOR DEDICATION
TO THE TOWN OF TRUCKEE
(AFFORDABLE HOUSING)

LOT AO
8 SUBD. 182
± 0.59 AC
OFFERED FOR DEDICATION
TO THE TOWN OF TRUCKEE
(AFFORDABLE HOUSING)

LOT AP
8 SUBD. 182
± 0.59 AC
OFFERED FOR DEDICATION
TO THE TOWN OF TRUCKEE
(AFFORDABLE HOUSING)

LOT AQ
8 SUBD. 182
± 0.59 AC
OFFERED FOR DEDICATION
TO THE TOWN OF TRUCKEE
(AFFORDABLE HOUSING)

LOT AR
8 SUBD. 182
± 0.59 AC
OFFERED FOR DEDICATION
TO THE TOWN OF TRUCKEE
(AFFORDABLE HOUSING)

LOT AS
8 SUBD. 182
± 0.59 AC
OFFERED FOR DEDICATION
TO THE TOWN OF TRUCKEE
(AFFORDABLE HOUSING)

LOT AT
8 SUBD. 182
± 0.59 AC
OFFERED FOR DEDICATION
TO THE TOWN OF TRUCKEE
(AFFORDABLE HOUSING)

LOT AU
8 SUBD. 182
± 0.59 AC
OFFERED FOR DEDICATION
TO THE TOWN OF TRUCKEE
(AFFORDABLE HOUSING)

LOT AV
8 SUBD. 182
± 0.59 AC
OFFERED FOR DEDICATION
TO THE TOWN OF TRUCKEE
(AFFORDABLE HOUSING)

LOT AW
8 SUBD. 182
± 0.59 AC
OFFERED FOR DEDICATION
TO THE TOWN OF TRUCKEE
(AFFORDABLE HOUSING)

LOT AX
8 SUBD. 182
± 0.59 AC
OFFERED FOR DEDICATION
TO THE TOWN OF TRUCKEE
(AFFORDABLE HOUSING)

LOT AY
8 SUBD. 182
± 0.59 AC
OFFERED FOR DEDICATION
TO THE TOWN OF TRUCKEE
(AFFORDABLE HOUSING)

LOT AZ
8 SUBD. 182
± 0.59 AC
OFFERED FOR DEDICATION
TO THE TOWN OF TRUCKEE
(AFFORDABLE HOUSING)

LOT BA
8 SUBD. 182
± 0.59 AC
OFFERED FOR DEDICATION
TO THE TOWN OF TRUCKEE
(AFFORDABLE HOUSING)

LOT BB
8 SUBD. 182
± 0.59 AC
OFFERED FOR DEDICATION
TO THE TOWN OF TRUCKEE
(AFFORDABLE HOUSING)

LOT BC
8 SUBD. 182
± 0.59 AC
OFFERED FOR DEDICATION
TO THE TOWN OF TRUCKEE
(AFFORDABLE HOUSING)

LOT BD
8 SUBD. 182
± 0.59 AC
OFFERED FOR DEDICATION
TO THE TOWN OF TRUCKEE
(AFFORDABLE HOUSING)

LOT BE
8 SUBD. 182
± 0.59 AC
OFFERED FOR DEDICATION
TO THE TOWN OF TRUCKEE
(AFFORDABLE HOUSING)

LOT BF
8 SUBD. 182
± 0.59 AC
OFFERED FOR DEDICATION
TO THE TOWN OF TRUCKEE
(AFFORDABLE HOUSING)

LOT BG
8 SUBD. 182
± 0.59 AC
OFFERED FOR DEDICATION
TO THE TOWN OF TRUCKEE
(AFFORDABLE HOUSING)

LOT BH
8 SUBD. 182
± 0.59 AC
OFFERED FOR DEDICATION
TO THE TOWN OF TRUCKEE
(AFFORDABLE HOUSING)

LOT BI
8 SUBD. 182
± 0.59 AC
OFFERED FOR DEDICATION
TO THE TOWN OF TRUCKEE
(AFFORDABLE HOUSING)

LOT BJ
8 SUBD. 182
± 0.59 AC
OFFERED FOR DEDICATION
TO THE TOWN OF TRUCKEE
(AFFORDABLE HOUSING)

LOT BK
8 SUBD. 182
± 0.59 AC
OFFERED FOR DEDICATION
TO THE TOWN OF TRUCKEE
(AFFORDABLE HOUSING)

LOT BL
8 SUBD. 182
± 0.59 AC
OFFERED FOR DEDICATION
TO THE TOWN OF TRUCKEE
(AFFORDABLE HOUSING)

LOT BM
8 SUBD. 182
± 0.59 AC
OFFERED FOR DEDICATION
TO THE TOWN OF TRUCKEE
(AFFORDABLE HOUSING)

LOT BN
8 SUBD. 182
± 0.59 AC
OFFERED FOR DEDICATION
TO THE TOWN OF TRUCKEE
(AFFORDABLE HOUSING)

LOT BO
8 SUBD. 182
± 0.59 AC
OFFERED FOR DEDICATION
TO THE TOWN OF TRUCKEE
(AFFORDABLE HOUSING)

LOT BP
8 SUBD. 182
± 0.59 AC
OFFERED FOR DEDICATION
TO THE TOWN OF TRUCKEE
(AFFORDABLE HOUSING)

LOT BQ
8 SUBD. 182
± 0.59 AC
OFFERED FOR DEDICATION
TO THE TOWN OF TRUCKEE
(AFFORDABLE HOUSING)

LOT BR
8 SUBD. 182
± 0.59 AC
OFFERED FOR DEDICATION
TO THE TOWN OF TRUCKEE
(AFFORDABLE HOUSING)

LOT BS
8 SUBD. 182
± 0.59 AC
OFFERED FOR DEDICATION
TO THE TOWN OF TRUCKEE
(AFFORDABLE HOUSING)

LOT BT
8 SUBD. 182
± 0.59 AC
OFFERED FOR DEDICATION
TO THE TOWN OF TRUCKEE
(AFFORDABLE HOUSING)

LOT BU
8 SUBD. 182
± 0.59 AC
OFFERED FOR DEDICATION
TO THE TOWN OF TRUCKEE
(AFFORDABLE HOUSING)

LOT BV
8 SUBD. 182
± 0.59 AC
OFFERED FOR DEDICATION
TO THE TOWN OF TRUCKEE
(AFFORDABLE HOUSING)

LOT BV
8 SUBD. 182
± 0.59 AC
OFFERED FOR DEDICATION
TO THE TOWN OF TRUCKEE
(AFFORDABLE HOUSING)

LOT BV
8 SUBD. 182
± 0.59 AC
OFFERED FOR DEDICATION
TO THE TOWN OF TRUCKEE
(AFFORDABLE HOUSING)

LOT BV
8 SUBD. 182
± 0.59 AC
OFFERED FOR DEDICATION
TO THE TOWN OF TRUCKEE
(AFFORDABLE HOUSING)

LOT BV
8 SUBD. 182
± 0.59 AC
OFFERED FOR DEDICATION
TO THE TOWN OF TRUCKEE
(AFFORDABLE HOUSING)

LOT BV
8 SUBD. 182
± 0.59 AC
OFFERED FOR DEDICATION
TO THE TOWN OF TRUCKEE
(AFFORDABLE HOUSING)

LOT BV
8 SUBD. 182
± 0.59 AC
OFFERED FOR DEDICATION
TO THE TOWN OF TRUCKEE
(AFFORDABLE HOUSING)

LOT BV
8 SUBD. 182
± 0.59 AC
OFFERED FOR DEDICATION
TO THE TOWN OF TRUCKEE
(AFFORDABLE HOUSING)

LOT BV
8 SUBD. 182
± 0.59 AC
OFFERED FOR DEDICATION
TO THE TOWN OF TRUCKEE
(AFFORDABLE HOUSING)

LOT BV
8 SUBD. 182
± 0.59 AC
OFFERED FOR DEDICATION
TO THE TOWN OF TRUCKEE
(AFFORDABLE HOUSING)

LOT BV
8 SUBD. 182
± 0.59 AC
OFFERED FOR DEDICATION
TO THE TOWN OF TRUCKEE
(AFFORDABLE HOUSING)

LOT BV
8 SUBD. 182
± 0.59 AC
OFFERED FOR DEDICATION
TO THE TOWN OF TRUCKEE
(AFFORDABLE HOUSING)

LOT BV
8 SUBD. 182
± 0.59 AC
OFFERED FOR DEDICATION
TO THE TOWN OF TRUCKEE
(AFFORDABLE HOUSING)

LOT BV
8 SUBD. 182
± 0.59 AC
OFFERED FOR DEDICATION
TO THE TOWN OF TRUCKEE
(AFFORDABLE HOUSING)

LOT BV
8 SUBD. 182
± 0.59 AC
OFFERED FOR DEDICATION
TO THE TOWN OF TRUCKEE
(AFFORDABLE HOUSING)

LOT BV
8 SUBD. 182
± 0.59 AC
OFFERED FOR DEDICATION
TO THE TOWN OF TRUCKEE
(AFFORDABLE HOUSING)

LOT BV
8 SUBD. 182
± 0.59 AC
OFFERED FOR DEDICATION
TO THE TOWN OF TRUCKEE
(AFFORDABLE HOUSING)

LOT BV
8 SUBD. 182
± 0.59 AC
OFFERED FOR DEDICATION
TO THE TOWN OF TRUCKEE
(AFFORDABLE HOUSING)

LOT BV
8 SUBD. 182
± 0.59 AC
OFFERED FOR DEDICATION
TO THE TOWN OF TRUCKEE
(AFFORDABLE HOUSING)

LOT BV
8 SUBD. 182
± 0.59 AC
OFFERED FOR DEDICATION
TO THE TOWN OF TRUCKEE
(AFFORDABLE HOUSING)

LOT BV
8 SUBD. 182
± 0.59 AC
OFFERED FOR DEDICATION
TO THE TOWN OF TRUCKEE
(AFFORDABLE HOUSING)

LOT BV
8 SUBD. 182
± 0.59 AC
OFFERED FOR DEDICATION
TO THE TOWN OF TRUCKEE
(AFFORDABLE HOUSING)

LOT BV
8 SUBD. 182
± 0.59 AC
OFFERED FOR DEDICATION
TO THE TOWN OF TRUCKEE
(AFFORDABLE HOUSING)

LOT BV
8 SUBD. 182
± 0.59 AC
OFFERED FOR DEDICATION
TO THE TOWN OF TRUCKEE
(AFFORDABLE HOUSING)

LOT BV
8 SUBD. 182
± 0.59 AC
OFFERED FOR DEDICATION
TO THE TOWN OF TRUCKEE
(AFFORDABLE HOUSING)

LOT BV
8 SUBD. 182
± 0.59 AC
OFFERED FOR DEDICATION
TO THE TOWN OF TRUCKEE
(AFFORDABLE HOUSING)

BASIS OF BEARINGS:
THE BASIS OF BEARINGS IS IDENTICAL TO THE FINAL MAP NO. 02-007 FOR THE VILLAGE AT GRAY'S CROSSING - PHASE 1 RECORDED IN BOOK 8 OF SUBDIVISIONS AT PAGE 182, O.R.N.C.

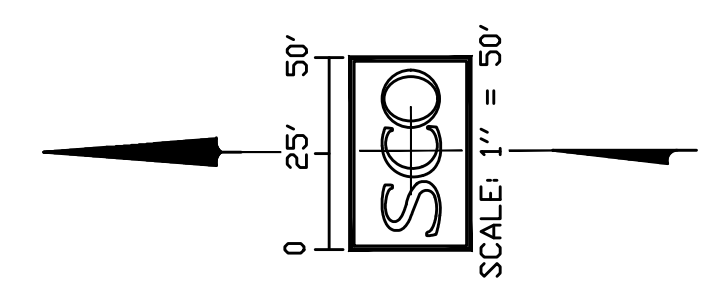

LEGEND	
"P.U.E."	PUBLIC UTILITY EASEMENT
"S.S.E."	SNOW STORAGE EASEMENT
"D.E."	DRAINAGE EASEMENT
(O.A.)	OVERALL
"B.P.E."	BICYCLE AND PEDESTRIAN EASEMENT
[Hatched Box]	50' SETBACK TO THE 100 YEAR FLOODPLAIN

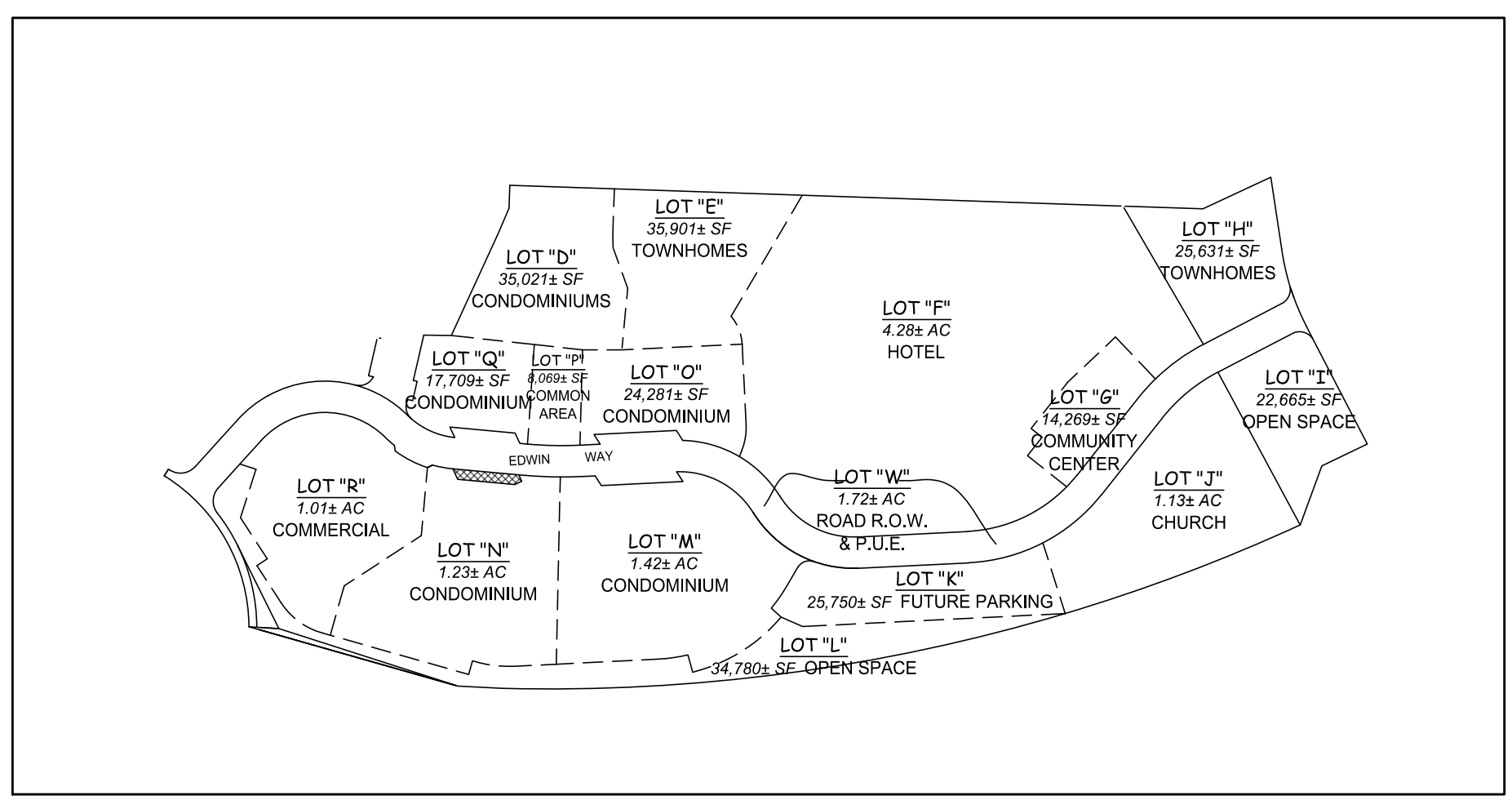

**EXISTING FINAL MAP 02-007
TO BE RESUBDIVIDED**
1" = 200'



Village at Gray's Crossing

PRELIMINARY
not for construction

Village at Gray's Crossing
Town of Truckee
APN 043-050-021,
043-060-001 to 008,
043-070-001 to 007

All drawings and written material appearing herein constitute original and unpublished work of the architect + engineer and may not be duplicated, used or disclosed without written consent of the architect + engineer

Job Number
Village at Gray's Crossing
Issue Date
18 June, 2019
Subject
Design Submittal

Drawing Title
**TENTATIVE
MAP**

Drawing Number
C-3