

Number : **SYSQ19731**

 Date : **04/23/2026**

 Expiration Date : **07/23/2026**
**Quoted**
**Company:**
**Village of Thornton**

 115 E. Margaret Street  
 Thornton, IL 60476  
 USA

**To:**
**Art Schweitzer**

 708-877-4459  
 aschweitzer@thorntonil.us

**Your Sales Rep:**
**Jeff Ryba**

 Braniff Communications, Inc.  
 Phone 708-597-3200  
 jryba@braniffcomm.com

**Prepared By:**
**Jeff Ryba**

 Braniff Communications, Inc.  
 Phone 708-597-3200  
 jryba@braniffcomm.com

**Notes:**

Replacement Warning Siren for Fire Station #1 location

Project Ref:

## New Replacement Warning Siren

		Terms	Ship Via	FOB	
		N30 EQUIP, SHIP DATE, N30 INSTALL SIGNOFF	Will Call / Installer	Origin	
Line	Qty	Part Number	Description	Unit Price	Ext. Price
<b>NEW WARNING SIREN EQUIPMENT</b>					
1	1	ECLIPSE8	SIREN, OMNI-DIRECTIONAL, 115dB, 500Hz, W/ HORNS	\$7,106.40	\$7,106.40
2	1	DCFCBH	MECAHNICAL SIREN CONTROLLER, DC, ONE-WAY, HIGH BAND	\$6,879.60	\$6,879.60
3	1	2001TRB	TRANSFORMER RECTIFIER PLUS	\$3,500.10	\$3,500.10
<b>INSTALLATION SERVICES</b>					
4	1	TK-IO-CUSTINS	INSTALLATION SERVICES, CUSTOM, INSTALLATION OF NEW SIREN EQUIPMENT ON A NEW 50' CLASS 2 TREATED TIMBER POLE INCLUDING RELATED INSTALLER PROVIDED MATERIAL AND HARDWARE. INCLUDES STANDARD DUTY BATTERIES, ANTENNA HARDWARE AND SIREN SITE COMMISSIONING SERVICES.	\$11,880.00	\$11,880.00
5	1	TK-IO-CUSTINS	SERVICES, CUSTOM, REMOVAL, HAUL-AWAY AND DISPOSAL OF EXISTING DEFECTIVE WARNING SIREN EQUIPMENT	\$2,745.00	\$2,745.00
6	1	TK-IO-CRTPAY-CU	ADMIN FEE-PREVAILING WAGE/CERTIFIED PAYROLL/DAVIS-BACON ACT.	\$1,390.00	\$1,390.00

Lead Time:

8 - 10 Week Lead Time, ARO.

SubTotal	<b>\$33,501.10</b>
Tax	
<b>Total USD</b>	<b>\$33,501.10</b>
Recurring Totals	<b>\$0.00</b>

This quotation is expressly subject to acceptance by Buyer of all terms stated on this and Federal Signal's terms of sale (available on request). Any exception to or modifications of such terms shall not be binding on Seller unless expressly accepted in writing by an authorized agent or office of Seller. Any order submitted to Seller on the basis set forth above, in whole or in part, shall constitute an acceptance by Buyer of Federal Signal's terms. Any such order shall be subject to acceptance by Seller in its discretion. Prices Subject To Change - Prices Based Upon Total Purchase - All Delivery, Training Or Consulting Services To Be Billed At Published Rates For Each Activity Involved. We Shall Not Be Liable For Any Loss Of Profits, Business, Goodwill, Data, Interruption Of Business, Nor For Incidental Or Consequential Merchantability Or Fitness Of Purpose, Damages Related To This Agreement.

Quote Approved By: \_\_\_\_\_

Closing Notes:

Taxes

Prices do not include taxes. Buyer shall pay Seller, in addition to the price of the goods, any applicable excise, sales, use or other tax (however designated) imposed upon the sale, production, delivery or use of the Goods or Services ordered to the extent required or not forbidden by law to be collected by Seller from Buyer, whether or not so collected at the time of the sale, unless valid exemption certificates acceptable to the taxing authorities are furnished to Seller before the date of invoice.

Cancellation Schedule - Material:

-Percentages shown are of total order value with weeks representing number of weeks from receipt of official order:

- 10% after 2 weeks.
- 20% after 4 weeks.
- 40% after 6 weeks.
- 80% after 8 weeks.

Cancellation Schedule - Services:

-If any cancellation of scheduled service visit occurs, Federal Signal reserves the right to impose cancellation charges as follows:

- Cancellation of visit within 7 days of mobilization - 50% of agreed upon labor and incurred expenses plus handling fee.
- Cancellation of visit within 2 days of mobilization - 100% of agreed upon labor and incurred expenses plus handling fee.

Delivery Schedule:

-From receipt of official purchase order, delivery is based upon the agreed upon schedule. Production does not commence until receipt of approved drawings to Code B (approved with comments)

Warranty/Guarantee:

Please see Federal Signal Limited Warranty Terms and Conditions document (attached)

Storage Charges:

-0.5% storage charge per month on total amount of invoice applies if product is not pickup/shipped within two weeks after signed FAT.

Quote Approved By: \_\_\_\_\_ Date: \_\_\_\_\_

This quotation is expressly subject to acceptance by Buyer of all terms stated on this and Federal Signal's terms of sale (available on request). Any exception to or modifications of such terms shall not be binding on Seller unless expressly accepted in writing by an authorized agent or office of Seller. Any order submitted to Seller on the basis set forth above, in whole or in part, shall constitute an acceptance by Buyer of Federal Signal's terms. Any such order shall be subject to acceptance by Seller in its discretion. Prices Subject To Change - Prices Based Upon Total Purchase - All Delivery, Training Or Consulting Services To Be Billed At Published Rates For Each Activity Involved. We Shall Not Be Liable For Any Loss Of Profits, Business, Goodwill, Data, Interruption Of Business, Nor For Incidental Or Consequential Merchantability Or Fitness Of Purpose, Damages Related To This Agreement.

# Eclipse<sup>8</sup> Omni-Directional Siren

## Features

- **Omni-directional coverage**
- **115dB(C) at 100 feet**
- **100% aluminum design**
- **Three distinct warning signals**
- **Full battery operation or battery back-up**
- **Ideal for outdoor warning**
- **5-year limited warranty**

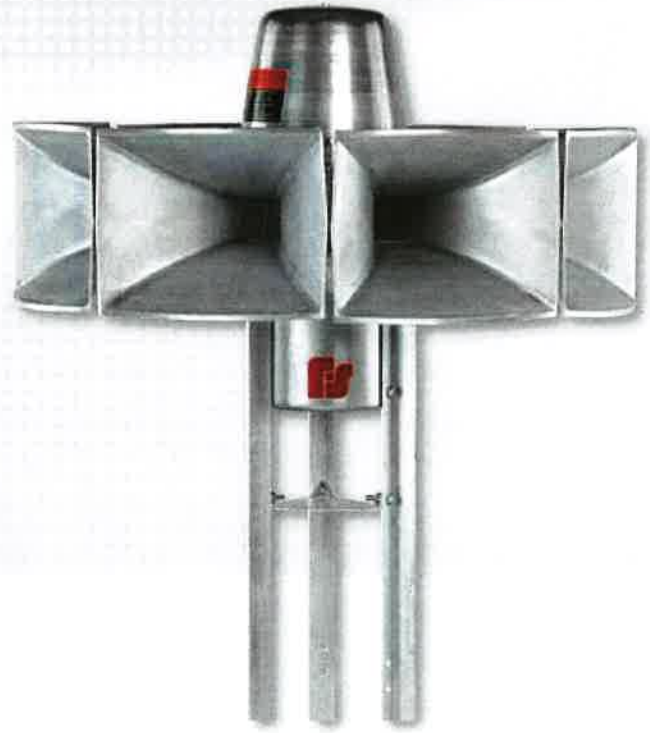

The Federal Signal Eclipse<sup>8</sup> is a mid-sized DC-powered, omni-directional siren for outdoor warning that produces high intensity warning signals. This powerful and lightweight siren provides coverage with a maximum sound pressure level of 115dB(C) at 100-ft (+/- 1dB). The Eclipse<sup>8</sup> siren is ideal for fire stations, communities, or nuclear plants. The high-decibel output provides maximum coverage with minimum installation costs. Operating from 48VDC, the siren utilizes the DC motor of our Federal Signal 2001-130 siren for proven reliability.

The siren's eight projector horns covers a 360-degree omni-directional area, with the capability of producing three signal options: steady, wail, and fast wail. The Eclipse<sup>8</sup> siren also offers a unique dual-tone feature. It provides low-frequency coverage while creating high frequency harmonics in the optimal range where most people hear better. The Eclipse<sup>8</sup> siren will supply a minimum of 15 minutes of continuous siren operation from its batteries even after 24 hours without AC power. The siren controls are available with battery (DC) operation, AC operation, and AC operation with battery back-up. One-way and two-way radio control or landline options are available. Designed to provide warning for events including: severe weather, local disasters, and all-hazard warning. The Eclipse<sup>8</sup> siren is a perfect choice to protect any community.

 **FEDERAL SIGNAL**  
Safety and Security Systems  
*Advancing security and well being.*

# Eclipse<sup>8</sup> Omni-Directional Siren

## Specifications

### Power Requirements\*

Siren Motor	48V (DC or full wave rectified AC) 112 Amps (nom.)
-------------	---

### Wiring

Siren Motor	2 AWG
-------------	-------

### Motor Type

Siren	Series Wound DC 7 Hp
-------	----------------------

### Signal Types

Steady, Wail, Fast Wail

### Output Frequency

Steady	525 Hz
Signal Duration	3 min. (programmable)
Signal Output (SPL):	115dB(C) (+/- 1dB(C)) (on axis) at 100' (30 m)
Effective Range at 70 dB(C)	2200 ft (370 m) at -10dB(C) per distance doubled

### Environmental

Operating Temperature**	-30°C to +60°C
-------------------------	----------------

### Weight

Siren Weight	255 lbs (116 kg)
Shipping Weight	380 lbs (173 kg)

\* Power requirements refer to the power supplied by the batteries or optional AC operation with battery back-up.

\*\* The siren can operate throughout this temperature range provided that battery temperature is maintained at -18°C or higher.

### Ordering Information

Eclipse <sup>8</sup>	115 dB(C) omni, electro-mechanical siren
RME	Roof or steel pole top mount and bracket
DCB	Battery cabinet and contactor
DCFBC (L, H or U)	Battery cabinet, contactor and controller board
DCFCTBD (H or U)	Two-way digital
DCFCTBD-IP	IP-enabled, two-way electro-mechanical controller
ACFCTBD (H or U)	Two-way digital, AC only
TRB	Transformer rectifier for AC or AC/DC operation
2001AC	AC control box (includes TRB)
FC (L,H or U)	Federal Controller (one-way, AC activation)

*Batteries are not included with any model.*



# DCFCTBD DC Two-Way Digital Controller

## Features

- **Two-way siren controller for 48VDC sirens**
- **Two-way radio control and status monitoring**
- **AFSK two-way signaling format**
- **Simultaneous single-tone, two-tone sequential, and DTMF, EAS, and POCSAG decoding.**
- **Push buttons for local activation**
- **UL Listed for general signaling**

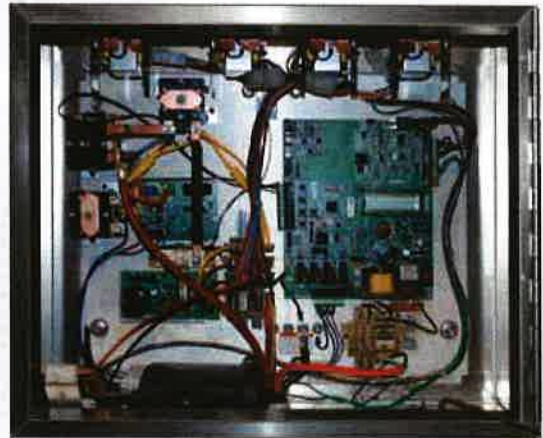

The Federal Signal DCFCTBD is a two-way digital, battery-operated status monitoring siren controller for use with the Federal Signal 2001-130 siren and Eclipse siren series. The controller interfaces with an off-the-shelf two-way radio transceiver and communicates to the base control via AFSK signaling. In addition to AFSK, the controllers will simultaneously decode any combination of single-tone, two-tone sequential, DTMF, POCSAG and EAS formats for activation. This makes the two-way controller compatible with virtually any existing siren control system.

All DCFCTBD models come equipped with four independent relay outputs that can be programmed to activate with various codes. There are four landline inputs and four local push buttons for activation, plus reset. Activation codes, relay timing, and optional warning sounds are programmed into the unit through a standard RS232 serial port or over-the-air from the central control point.

The DCFCTBD offers six user programmable functions in addition to the five pre-set functions: arm, disarm, report, growl test and master reset. The controller includes the necessary sensors and wiring to supply information on the following areas of operation: AC power status, communications status, low battery status, intrusion, siren activation, current intrusion, siren rotation and local activation.

 **FEDERAL SIGNAL**  
Safety and Security Systems  
*Advancing security and well being.*

# DCFCTBD DC Two-Way Digital Controller

## Specifications

### Electrical

AC supply voltage	120 VAC @ 4.0 Amps
Current Draw	+/- 10%, 50/60 Hz, maximum standby current
Power Supply	6A @ 13.3VDC
Battery Backup	48VDC
Current Draw	< .2 Amps in standby

### Serial Ports

Serial Port Protocol	RS232C 1200, N, 8, 1
----------------------	----------------------

### Transceiver

Programmable Frequency	Power Out and Private Line options. For further details consult the Motorola® product Manual.
------------------------	---

### Signaling Format

AFSK	1200 baud, MSK (Minimum Shift Key) modem type Useable decode sensitivity: 12dB SINAD (min.)
DTMF	3-12 standard DTMF characters

### Two-Tone Sequential

Frequency Range	282 Hz - 3000 Hz (non-CTCSS) 400 Hz - 3000 Hz (CTCSS)
Tone Timing	.5 sec - .25 sec min., 8 sec max
Intertone Gap	400ms (maximum)
Tone Accuracy	+/- 1.5%
Tone Spacing	5.0% preferred, 3% min.

### Single Tone

Frequency Range	282 Hz - 3000 Hz
Tone Timing	0.5 sec. - 8 sec maximum
Tone Accuracy	+/- 1.5%
Tone Spacing	5.0% preferred, 3% min.
EAS	Supports standard EAS codes and wildcards
POCSAG	Supports binary AFSK 512 Baud numeric messages.

### Relay Outputs

4 relay outputs	SPST
Contact Rating	(4 relays standard) 5A @ 28VDC - 5A @ 240VAC

### Audio Output

Output Voltage	>2V Peak to Peak
Maximum Load	8 Ohms
Total Harmonic Distortion	<10% @ 1kHz Sinewave

### Environmental

Operating Temperature	-30°C to 65°C
-----------------------	---------------

### Controller Dimensions (with battery cabinet)

HxWxD	62.5" x 23.5" x 16.94" 1588mm x 597mm x 430mm NEMA 4X Rated
-------	--

### Battery Cabinet Dimensions

HxWxD	18" x 28" x 15.19" 457mm x 711mm x 386mm Vented NEMA 4X Rated
-------	--

### Shipping Weight

Approx. Shipping Weight	300 lbs. (136.36 kg)
Actual Weight	234 lbs. (106.3 kg)

### 2001TR: AC Primary Operation

Operating Voltage	208/220/240 VAC single phase
Current Requirements	30 Amps (approx.)
Dimensions	23" x 11" x 10" (584mm x 279mm x 254mm)
Product Weight	150 lbs. (68.2 kg)

### Order information

DCFCTBD <sup>1,2</sup>	Two-way Federal Controller
DCFCTBDH <sup>1,2</sup>	Two-way Federal Controller, high band 136-174 MHz
DCFCTBDU <sup>1,2</sup>	Two-way Federal Controller, UHF band 403-470 MHz
DCFCTBD-IP <sup>1,3</sup>	IP-enabled two-way electro-mechanical controller

### Options

FSPWARE	Federal Programming Software (Non-Digital Applications)
SFCDWARE	Federal Commander Digital Software (See literature for details)
Q-DC-IP <sup>1,3</sup>	Retrofit kit to upgrade existing controller to IP
ES-PROG-DTMF	Two-Way DTMF Programming

<sup>1</sup> For use with 2001-130 and Eclipse siren series.

<sup>2</sup> Antenna and cable are not included with radio activation control and must be ordered separately.

<sup>3</sup> Broadband radio and Codespear software sold separately.

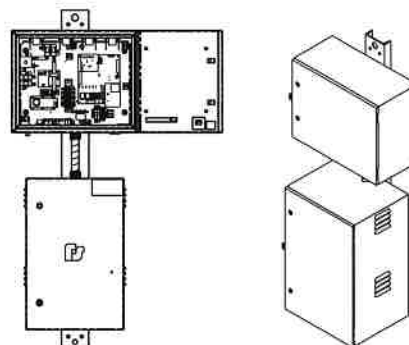

*Advancing security and well being.*



**TERMS AND CONDITIONS OF SALE (Goods and Services)**

Effective 2-20-2026

1. **DEFINITIONS.** In these Terms and Conditions of Sale, "Seller" means Federal Signal Corporation, including any division or subsidiary of Federal Signal Corporation; "Buyer" means the person or entity that placed the order or on whose behalf the order is placed; "Goods" means the goods identified in Seller's acknowledgment of Buyer's order; "Services" means the services identified in Seller's acknowledgment of Buyer's order; "Contract" means the written agreement (which shall include these Terms and Conditions) between Buyer and Seller for the supply of the Goods and/or provision of Services; and "Contract Price" means the price payable to Seller by Buyer for the Goods and/or Services.
2. **ORDERS; CONTRACT.** All orders must be in writing. Buyer understands and agrees that any order, upon Acceptance by Seller, shall be subject to these Terms and Conditions of Sale. Seller objects to and shall not be bound by any additional or different terms, whether printed or otherwise, in Buyer's order or in any other communication from Buyer to Seller, or any trade usage or course of dealing between Buyer and Seller, unless expressly agreed to in writing by Seller in Seller's acknowledgment of Buyer's order. If the details of the Goods or Services described in Seller's quotation differ from those set out in Seller's acknowledgment, the latter shall apply. Seller reserves the right to make minor modifications and/or improvements to the Goods before delivery provided that the performance of the Goods is not adversely affected and that neither the Contract Price nor the delivery date is affected.
3. **EFFECTIVE DATE; CANCELLATION.** The Contract shall become effective only upon the date of acceptance of Buyer's order by Seller's written acknowledgment or upon Seller's commencement of performance, whichever is first ("Acceptance"). Buyer may not cancel or change an order after Acceptance by Seller without the written consent of Seller. Notwithstanding the forgoing, Seller may, in its sole discretion, agree to a written request from Buyer for cancellation of an open order under the following conditions: Buyer shall be subject to cancellation charges equal to the greater of (i) 110% of the cost of work completed and/or custom materials purchased at the time the request is delivered, or (ii) a percentage of the canceled portion of the Contract calculated as follows:

10% - if cancelled more than 2 weeks from the Effective Date;  
20% - if cancelled more than 4 weeks from the Effective Date;  
40% - if cancelled more than 6 weeks from the Effective Date;  
80% - if cancelled more than 8 weeks from the Effective Date.

**Cancellation Schedule - Services:**

If services are cancelled within 1 week of the scheduled mobilization date; 110% of unrecoverable out-of-pocket costs + 50% of scheduled services will be charged.

If services are cancelled within 2 days of the scheduled mobilization date; 110% of unrecoverable out-of-pocket costs + 100% of scheduled services will be charged.

Notwithstanding anything to the contrary herein, any service and/or commissioning line items that remain open and unperformed for a period of twenty-four (24) months or more from the Effective Date or Issuance of Buyer's Order, whichever is first shall be deemed automatically cancelled without further notice or action by either party. Upon such automatic cancellation, Buyer shall remain liable for all costs and charges incurred by Seller up to the date of cancellation, including but not limited to unrecoverable out-of-pocket costs, work completed, and custom materials purchased.

4. **PRICE AND PAYMENT TERMS.** Unless previously withdrawn, Seller's quotation is open for acceptance within the period stated therein or, when no period is so stated, within thirty days after its date of issuance to Buyer. Prices are subject to increase by Seller based on Seller's prices in effect at the time of shipment in all instances where the specified shipment date is more than 30 days from the date of the order from Buyer. Unless otherwise specified in the Contract or Seller's applicable price list, prices are FOB Seller's point of shipment, and the terms of payment are NET 30 days from the date of invoice. Amounts not paid when due shall bear interest for each day after the due date calculated at the annual rate of 18% or the highest rate permitted by law, whichever is less. Freight, packing and handling will be charged at Seller's standard rates, which are available upon request by Buyer. If the Contract is for more than one unit of Goods, the Goods may be shipped in a single lot or in several lots at the discretion of Seller. In such event, each such shipment shall be paid separately and Buyer shall be responsible for all transportation charges. Seller may require full or partial payment or payment guarantee in advance of shipment whenever, in its opinion, the financial condition of Buyer so warrants. Payment by credit card may be subject to a service charge. If Buyer requires Seller to submit invoices through an electronic portal or other third-party invoicing platform, Buyer shall pay Seller a fee of \$150.00 per order.

5. **TITLE; RISK OF LOSS.** Title to, ownership of, and risk of loss or damage to the Goods shall pass to the Buyer, and Buyer shall be responsible for insurance of the Goods, upon delivery of the Goods to the carrier. Alternatively, if it is expressly stated in the Contract that Seller is to procure insurance for the Goods after delivery to the carrier, such insurance will be charged at the carrier's standard rates. "FOB" and any other delivery term used in the Contract shall be defined in accordance with the latest version of Incoterms. Buyer shall have sole responsibility for processing and collection of any claim of loss against the carrier.
6. **TAXES.** Prices do not include taxes. Buyer shall pay Seller, in addition to the price of the goods, any applicable excise, sales, use or other tax (however designated) imposed upon the sale, production, delivery or use of the Goods or Services ordered to the extent required or not forbidden by law to be collected by Seller from Buyer, whether or not so collected at the time of the sale, unless valid exemption certificates acceptable to the taxing authorities are furnished to Seller before the date of invoice.
7. **DELIVERY; FORCE MAJEURE.** Unless otherwise stated in Seller's quotation, all periods stated for delivery or completion run from the Effective Date and are to be treated as estimates only and are not guaranteed. If Seller is delayed in or prevented from performing any of its obligations under the Contract due to the acts or omissions of Buyer or its agents, the delivery/completion period and the Contract Price shall both be adjusted as necessary. If delivery is delayed due to any act or omission of Buyer, or if having been notified that the Goods are ready for shipment, Buyer fails to take delivery or provide adequate shipping instructions, Seller shall be entitled to place the Goods into storage at Buyer's expense. Upon placing the Goods into storage, delivery shall be deemed to be complete, risk in the Goods shall pass to Buyer and Buyer shall pay Seller accordingly. The Contract (other than Buyer's obligation to pay all sums due to Seller in accordance with the Contract) shall be suspended, without liability, in the event and to the extent that its performance is prevented or delayed due to any circumstance beyond the reasonable control of the party affected, including but not limited to: Act of God, war, armed conflict or terrorist attack, riot, fire, explosion, accident, flood, disease, health epidemic or pandemic, sabotage; governmental decisions or actions (including but not limited to prohibition of exports or re-exports or the failure to grant or the revocation of applicable export licenses), or labor trouble, strike, lockout or injunction. Seller shall have no obligation to deliver any hardware, software, services or technology unless and until it has received any necessary licenses or authorizations or has qualified for general licenses or license exceptions under applicable import, export control and sanctions laws, regulations, orders and requirements, as they may be amended from time to time (including without limitation those of the United States, the European Union and the jurisdiction in which Seller is established or from which the items are supplied). If for any reason any such licenses, authorizations or approvals are denied or revoked, or if there is a change in any such applicable laws, regulations, orders or requirements that would prohibit Seller from fulfilling the Contract, or would in the reasonable judgment of Seller otherwise expose Seller to a risk of liability under applicable laws, regulations, orders or requirements, Seller shall be relieved without liability of all obligations under the Contract.

If either party is delayed or prevented from performance of its obligations by reason of this clause for more than 180 consecutive calendar days, either party may terminate the then unperformed portion of the Contract by notice in writing given to the other party, without liability provided that Buyer shall be obliged to pay the reasonable cost and expense of any work in progress and to pay for all Goods delivered and Services performed as at the date of termination. Seller may deliver by installments, and each delivery shall constitute a separate Contract. Failure by Seller to deliver any one or more of the installments in accordance with their terms shall not entitle Buyer to terminate the whole Contract or treat it as repudiated.

8. **INSPECTION.** Buyer shall inspect the goods immediately upon the receipt thereof. All claims for shortfalls in quantity or for incorrect delivery or for any alleged defect in Seller's performance under this Contract, capable of discovery upon reasonable inspection, must be fully set forth in writing and received by Seller within five days of Buyer's receipt of the Goods. Failure to make any such claim within said period shall constitute a waiver of such claim and an irrevocable acceptance of the Goods by Buyer.
9. **DEDUCTIONS AND RETURNS.** Buyer must contact the factory before returning any merchandise. Goods in new, unused and undamaged condition that are resalable as new products without modification or repackaging may be returned to Seller for credit only upon the Seller's prior written consent (such consent to be in the sole discretion of Seller) and upon terms specified by Seller, including prevailing restocking, freight, and handling charges. A Return Material Authorization (RMA) must be obtained before returning merchandise for credit. All returns are subject to inspection of merchandise and any defects in the units will be charged back to the Buyer at the cost of parts and labor. Credit deductions will not be honored unless covered by an RMA. Buyer assumes all risk of loss for such returned goods until actual receipt thereof by Seller. Agents of Seller are not authorized to accept returned goods or to grant allowances or adjustments with respect to Buyer's account.

10. LIMITED WARRANTY.

NOTICE: IF ANY GOODS, INCLUDING ANY COMPONENT PART OF ANY GOODS, OR SERVICES SOLD BY SELLER ARE ACCOMPANIED BY A SEPARATE MANUFACTURER'S WARRANTY COVERING SUCH GOODS OR SERVICES, THE TERMS OF SUCH WARRANTY, INCLUDING ALL LIMITATIONS OF SUCH WARRANTY, SHALL GOVERN THOSE GOODS OR SERVICES, AND ANY WARRANTY OF SELLER OTHERWISE APPLICABLE TO SUCH GOODS OR SERVICES SHALL NOT APPLY.

- A. Goods. Subject to the foregoing, Seller's limited warranty for any new Goods which are the subject of any Seller's acknowledgment of Buyer's order may be found at [www.fedsig.com/SSG-Warranty](http://www.fedsig.com/SSG-Warranty), or maybe obtained by writing to Federal Signal Corporation, 2645 Federal Signal Drive, University Park, IL 60484; by email to [info@federalsignal.com](mailto:info@federalsignal.com); or by calling 708/534-3400.
- B. Services Seller warrants that Services provided by Seller will be performed with all reasonable skill, care and diligence and in accordance with standard industry practice. Seller will correct defects in Services provided by Seller and reported to Seller within ninety days after completion of such Services. Services corrected in accordance with this Section shall be subject to the foregoing warranty for an additional ninety days from the date of completion of correction of such Services.

11. REMEDIES AND LIMITATIONS OF LIABILITY. The remedies contained the preceding paragraph constitute the sole recourse against Seller for breach of any of Seller's obligations under the Contract, whether of warranty or otherwise. In no event shall Seller be liable for consequential damages nor shall Seller's liability on any claim for any direct, incidental, consequential or special damages arising out of or connected with the Contract or the manufacture, sale, delivery or use of the Goods or Services exceed the purchase price of the Goods or Services. The term "consequential damages" shall include, but not be limited to, loss of anticipated profits, business interruption, loss of use, revenue, reputation and data, costs incurred, including without limitation, for capital, fuel, power and loss or damage to property or equipment. It is expressly understood that any technical advice furnished by Seller with respect to the use of the Goods is given without charge, and Seller assumes no obligation or liability for the advice given, or results obtained, all such advice being given and accepted at Buyer's risk.

12. LIMITED INDEMNITY AGAINST INFRINGEMENT. Seller shall, at its own expense, defend any litigation resulting from sale of the Goods to the extent that such litigation alleges that the Goods or any part thereof infringes any United States patent, copyright, or trademark, provided that such claim does not arise from the use of the Goods in combination with equipment or devices not made by Seller or from modification of the Goods, and further provided that Buyer notifies Seller immediately upon its obtaining notice of such impending claim and cooperates fully with Seller in preparing a defense. If Buyer provides to Seller the authority, assistance, and information Seller needs to defend or settle such claim, Seller shall pay any final award of damages in such suit and any expense Buyer incurs at Seller's written request, but Seller shall not be liable for a settlement made without its prior written consent. If the Goods are held to be infringing and the use thereof is enjoined, Seller shall, at its option, either (i) procure for the Buyer the right to use the Goods, (ii) replace the Goods with others which do not constitute infringement, or (iii) remove the infringing Goods and refund the payment(s) made therefor by Buyer. The foregoing states the Buyer's sole remedy for, and Seller's entire liability and responsibility for, infringement of any patent, trademark, or copyright relating to the Goods provided hereunder. THIS LIMITED INDEMNITY IS IN LIEU OF ANY OTHER STATUTORY OR IMPLIED WARRANTY AGAINST INFRINGEMENT.

13. INTELLECTUAL PROPERTY RIGHTS. All drawings, data, designs, tooling, equipment, procedures, engineering changes, inventions, trade secrets, copyrights, mask works, source code, object code, patents, patent applications, know-how, computer and/or product software and all parts thereof, trademarks and all other information, technical or otherwise which was developed, made or supplied by or for Seller in the production of any Goods or Services sold hereunder will be and remain the sole property of Seller (or its licensors, if any). Buyer agrees not to reverse engineer any Goods purchased hereunder.

14. EXPORT REGULATIONS. Buyer agrees to comply fully with all laws and regulations concerning the export of goods from the United States, including, but not limited to Export Administration Rules ("EAR"), regulations of the Office of Foreign Asset Control ("OFAC"), International Traffic in Arms Regulations ("ITAR"), as well as Denial Order and Entry lists under EAR and Specially Designated Nationals and Blocked Persons list under OFAC regulations.

15. INSTALLATION. In those circumstances where Seller has agreed to install Goods for Buyer, the following provisions shall control:

- A. Responsibility. Installation shall be by Buyer unless otherwise specifically agreed to in writing by Seller.
- B. Receiving Product and Staging Location. Buyer is responsible to receive, store and protect all Goods intended for installation purposes, including, but not exclusively, siren equipment, poles, batteries, and installation materials. Materials received in cardboard containers must be protected from all forms of precipitation. Additionally, Buyer is to provide a staging area of an appropriate size for installation contractors to work from and to store equipment overnight.

- C. Installation Methods & Materials. Installation is based on methods and specifications intended to meet applicable safety and installation codes and regulations. Design changes required by Buyer may result in additional charges.
  - D. Radio Frequency Interference. Seller is not responsible for RF transmission and reception affected by system interference beyond its control.
  - E. Installation Site Approval. Buyer must provide signed documentation to Seller, such as the "WARNING SITE SURVEY FORM" or a document with the equivalent information, that Seller is authorized to commence installation at the site designated by Buyer before Seller will commence installation. Once installation has started at an approved site, Buyer is responsible for all additional costs incurred by Seller for redeployment of resources if the work is stopped by Buyer or its agents, property owners, or as the result of any governmental authority or court order, or if it is determined that installation is not possible at the intended location, or the site is changed for any reason by the Buyer.
  - F. AC Power Hookup. Buyer is responsible to coordinate and pay for all costs to bring proper AC power to the electrical service disconnect installed adjacent to the controller cabinet, unless these services are quoted by Seller.
  - G. Permits & Easements. Seller will obtain and pay for electrical and right-of-way work permits as necessary for installations. Buyer is responsible for obtaining and payment of all other required easements, permits, or other fees required for installation, unless specifically quoted.
  - H. Soil Conditions Clause. In the event of poor site conditions including, but not limited to rock, cave-ins, high water levels, or inability of soil to provide stable installation to meet specifications, Seller will direct installation contractors to attempt pole installation for a maximum of 2 hours. Buyer approval will be sought when pole installation exceeds 2 hours and abandoned if Seller cannot obtain approval in a timely manner.
  - I. Contaminated Sites. Seller is not responsible for cleanup and restoration of any installation sites or installer equipment where contaminated soil is encountered. Seller will not knowingly approve installation at any site containing contaminants. Buyer must inform Seller when known or suspected soil contaminants exist at any intended installation site.
  - J. Site Cleanup. Basic installation site cleanup includes installation debris removal, general site cleanup, and general leveling of affected soil within 30' of the pole. Additional site restoration quotes are available.
  - K. Waste Disposal. Buyer is responsible for providing disposal of all packing materials including shipping skids and containers.
  - L. Work Hours. All installation quotes are based on the ability to work outdoors during daylight hours and indoors from 7 AM to 7 PM Monday through Saturday. Work restrictions or limitations imposed by Buyer or its agents may result in additional charges being assessed to Buyer for services.
  - M. Project Reporting. Installation & Service Progress Reports will be provided on a regular basis, normally every week during active installation, unless pre-arranged otherwise by mutual agreement.
  - N. Safety Requirements & Compliance. Seller requires that all subcontractors and their employees follow applicable laws and regulations pertaining to all work performed, equipment utilized and personal protective gear common to electrical and construction site work performed in the installation of Seller equipment. Additional safety compliance requirements by Buyer may result in additional charges assessed to Buyer for the time and expenses required to comply with the additional requirements.
16. ASSIGNMENT AND SUBCONTRACTING. Seller may assign its rights and obligations by giving Buyer written notice thereof but without being obligated to obtain Buyer's consent prior thereto. In the event of an assignment, Seller shall be discharged of any liability pursuant to those purchase orders which have been assigned or delegated. Customer may not assign its rights nor delegate its obligations under any or all of its purchase orders unless Seller's written consent is obtained prior thereto and any such assignment or delegation without such consent shall be void.

17. **DEFAULT, INSOLVENCY AND CANCELLATION.** Seller shall be entitled, without prejudice to any other rights it may have, to cancel the Contract immediately, in whole or in part, by notice in writing to Buyer, if (a) Buyer is in default of any of its obligations under the Contract and fails, within 20 (twenty) days of the date of Seller's notification in writing of the existence of the default, either to rectify such default if it is reasonably capable of being rectified within such period or, if the default is not reasonably capable of being rectified within such period, to take and diligently continue action to remedy the default or (b) on the occurrence of an Insolvency Event in relation to Buyer. "Insolvency Event" in relation to Buyer means any of the following: (i) a meeting of creditors of Buyer being held or an arrangement or composition with or for the benefit of its creditors being proposed by or in relation to Buyer; (ii) a receiver, administrator or similar person taking possession of or being appointed over or any distress, execution or other process being levied or enforced (and not being discharged within seven days) on the whole or a material part of the assets of Buyer; (iii) Buyer ceasing to carry on business or being unable to pay its debts; (iv) Buyer or its equity holders or the holder of a qualifying floating charge giving notice of their intention to appoint, or making an application to the court for the appointment of, an administrator; (v) a petition being presented (and not being discharged within 30 days) or a resolution being passed or an order being made for the administration or the winding-up, bankruptcy or dissolution of Buyer; or (vi) the happening in relation to Buyer of an event analogous to any of the above in any jurisdiction in which it is incorporated or resident or in which it carries on business or has assets. Seller shall be entitled to recover from Buyer or Buyer's representative all costs and damages incurred by Seller as a result of such default or cancellation, including all costs of collection and a reasonable allowance for overheads and profit (including but not limited to loss of prospective profits and overheads).
18. **SEVERABILITY.** If any term, clause or provision contained in the sales contract is declared or held invalid by a court of competent jurisdiction, such declaration or holding shall not affect the validity of any other term, clause or provision herein contained.
19. **NO WAIVER.** No waiver by either party with respect to any breach or default or of any right or remedy and no course of dealing or performance, shall be deemed to constitute a continuing waiver of any other breach or default or of any other right or remedy, unless such waiver be expressed in writing and signed by the party to be bound.
20. **NOTICES.** All notices and claims in connection with the Contract must be in writing.
21. **INTEGRATION.** These terms and conditions supersede all other communications, negotiations and prior oral or written statements regarding the subject matter of these terms and conditions.
22. **GOVERNING LAW AND LIMITATIONS.** The formation and performance of the sales contract shall be governed by the laws of the State of Illinois. Venue for any proceeding initiated as the result of any dispute between the parties that arises under this Agreement shall be either the state or federal courts in Cook or DuPage County, Illinois. Whenever a term defined by the Uniform Commercial Code as adopted in Illinois is used in these standard terms, the definition contained in said Uniform Commercial Code is to control. Any action by the Buyer for breach of the sales contract or any covenant or warranty contained herein must be commenced within one year after the cause of action accrued.
23. **U.N. CONVENTION.** Pursuant to Article 6 of the United Nations Convention on Contracts for the International Sale of Goods (the "UN Convention"), the Parties agree that the UN Convention shall not apply to this Agreement.



## LIMITED WARRANTY POLICY

### Effective January 19, 2026

Federal Signal Corporation ("Federal Signal"), subject to the terms, conditions and exceptions contained herein, warrants each NEW product to be free from defects in material and workmanship, under normal and proper use, care, maintenance and required service only. Start of Warranty, Warranty periods and exceptions to the foregoing Limited Warranty are contained on the Schedule of Products included in this document and are subject to change at the sole discretion of Federal Signal.

#### SPECIFIC EXCLUSIONS AND EXCEPTIONS

This Limited Warranty does NOT apply nor is it extended to products that are not manufactured by Federal Signal. These products may be covered by a separate limited warranty provided by the particular manufacturer, and all claims and questions regarding the same are to be directed to the particular manufacturer. Goods sourced by Seller from a third party for resale to Buyer shall carry only the warranty extended by the original manufacturer.

Domes, lenses, lamps, and batteries installed on Federal Signal products are specifically excluded. Repair or replacement of any product(s) or part(s) under this warranty does NOT extend the term of this warranty, and such product(s) or part(s) shall remain covered by the unexpired portion of the warranty period or for ninety (90) days from the date of return to Federal Signal, whichever is later. This limited warranty applies ONLY to the initial or first installation of the product. This limited warranty shall not apply to products (1) that have been subjected to neglect, abuse, misuse, improper installation, inadequate maintenance, or damage due to improper use of cleaning or cleaning materials or chemicals, or non-compliance with Federal Signal's storage, installation, operation, maintenance or environmental requirements; (2) that have undergone any modification or repair not previously authorized by Federal Signal in writing, or service, repair or modification by or from any facility other than an authorized Federal Signal service center or technician, or that use non-authorized software or spare or replacement parts; or (3) that fail due to reasonable and normal use or wear and tear, or materials made, furnished, or specified by the Buyer or end user.

During the specific warranty periods set forth below, Federal Signal will, at its sole option, repair or replace the product(s) or particular part(s) that are found to be defective in either material or workmanship or, in its sole discretion, refund the purchase price for such product(s) or part(s), which are returned or delivered, transport or shipping prepaid by the Buyer or end user, to either Federal Signal or its designated and authorized warranty service center. This limited warranty does not cover travel expenses, the cost of specialized equipment for gaining access to the product(s) or part(s), or labor charges for removal and re-installation of the product.

No person or affiliated company representative is authorized to alter the terms of this warranty, to give any other warranties, to extend the term or duration of this warranty, or to assume any other liability on behalf of Federal Signal in connection with the sale, servicing, or repair of any product manufactured by the Federal Signal.

Federal Signal reserves the right to make design changes and improvements in its products without imposing any obligation upon itself to change or improve previously manufactured products.

The use in the product of any part other than parts approved by Federal Signal may invalidate this warranty. Federal Signal reserves the right to determine, in its sole discretion, if the use of non-approved parts invalidates this warranty.

THIS WARRANTY IS IN LIEU OF ALL OTHER WARRANTIES, EXPRESS OR IMPLIED, INCLUDING, WITHOUT LIMITATION, WARRANTIES OF MERCHANTABILITY AND FITNESS FOR A PARTICULAR PURPOSE, AND REGARDLESS OF ANY FAILURE OF ESSENTIAL PURPOSE. ALL OTHER WARRANTIES OF WHATSOEVER KIND AND NATURE, WHETHER EXISTING IN CONTRACT OR AT LAW, ARE HEREBY AND FOREVER DISCLAIMED. UNDER NO CIRCUMSTANCES WILL FEDERAL SIGNAL BE LIABLE OR RESPONSIBLE FOR SPECIAL, COMPENSATORY, INCIDENTAL, CONSEQUENTIAL OR PUNITIVE DAMAGES, LOST PROFITS, LOST SALES, OR LOSS OF USE OR LOSS OF BUSINESS OPPORTUNITY BY OR THROUGH THE USE OF THE PRODUCT. FEDERAL SIGNAL'S SOLE AND MAXIMUM LIABILITY WITH RESPECT TO THE PRODUCT, OTHER THAN ITS OBLIGATIONS SET FORTH ABOVE, SHALL BE THE TOTAL PURCHASE PRICE PAID FOR THE PRODUCT.



LIMITED WARRANTY — SCHEDULE OF PRODUCTS

**Federal Signal Corporation – Public Safety Systems Division (Police, Fire/EMS, Work Truck)**

	Warranty Period for Parts replacement from the date of manufacture stamped on the product	Warranty period for Factory Labor from the date of delivery to the first user-purchaser
<b>STANDARD WARRANTY COVERAGE</b>		
<b>AUDIBLE</b>		
Speakers	2 years	1 year
Pathway™	5 years	5 years
Pathfinder®	5 years	5 years
<b>LED PRODUCTS</b>		
All LED (Light Emitting Diode) products unless otherwise noted	5 years	5 years
MicroPulse® LED lights (shipped prior to January 1, 2021)	3 years	3 years
MicroPulse® LED lights (shipped on or after January 1, 2021)	5 years	5 years
416300 Series (shipped prior to January 1, 2021)	3 years	3 years
416300 Series (shipped on or after January 1, 2021)	5 years	5 years
MB1 LED Message Board	3 years	3 years
Commander® Series Flex	3 years	3 years
4200S-A Perimeter Light	3 years	3 years
4200S/8200S SignalMaster™	3 years	3 years
SignalTech® Lights	3 years	3 years
ICON™ Series	3 years	3 years
Renegade LED	3 years	3 years
Firebolt LED Class 3	3 years	3 years
<b>OTHER PRODUCTS</b>		
Littlite® Map lights	5-year warranty on LED components Limited lifetime warranty on mechanical components	5-year warranty on LED components Limited lifetime warranty on mechanical components
Reverse Camera Systems	2 years	2 years
Stinger Spike Systems	5 years	5 years
DFC Series Push Bumper	3 years	3 years
FSLink® Programmer	1 year	1 year
Atkinson Dynamics® Intercoms	2 years	1 year
Switch Boxes SW200, SW300, SW400SS	3 years	3 years
Mounting Bar	3 years	3 years
Littlite Platform Series	3 years	3 years
Convergence Network Controllers & Relay Modules	3 years	3 years
FSDirect™ Control Module	5 years	5 years
Backup Alarms	3 years	3 years
Mounts, brackets, all other products not specifically listed below	3 years	3 years

NOTE: Domes, lenses, lamps, and batteries are NOT covered under warranty.



## LIMITED WARRANTY — SCHEDULE OF PRODUCTS

Federal Signal Corporation – Systems Division	
PRODUCT*	WARRANTY PERIOD FOR PARTS REPLACEMENT AND FACTORY PERFORMANCE LABOR**
<b>MECHANICAL SIRENS</b>	
Mechanical Sirens	5 years parts and labor from date of delivery, return to factory for service
<b>ELECTRONIC SIRENS</b>	
MOD Series	2 years parts and labor from date of delivery, return to factory for service
DSA Series	
<b>CONTROLLERS</b>	
SS2000+	2 years parts and labor from date of delivery, return to factory for service
FC Series	
DC Series	
UltraVoice Series	
<b>SPEAKERS</b>	
Informers	1 year parts and labor from date of delivery, return to factory for service
IP Speakers	
100 W Speakers	
<b>ECHO INTERCOMS</b>	
ECHO Intercoms	5 years parts and labor from date of delivery, return to factory for service
<b>OEM PRODUCTS</b>	
PC Equipment	Federal Signal utilizes the original manufacturer's warranty
Field Devices	
Batteries	
UPS Systems	
PABX Systems	
Base Stations	
Solar Equipment	
<b>PAGA</b>	
PAGA	18 months from shipment or 12 months from commissioning system field acceptance whichever is sooner covering parts and labor, return to factory for service
<b>SOFTWARE</b>	
Commander®	For more information, <a href="#">click here</a> to refer to the Commander End User License Agreement.
CommanderOne®	For more information, <a href="#">click here</a> to refer to the CommanderOne End User License Agreement.

Federal Signal offers extended warranties and software maintenance agreements – contact Federal Signal for further information.

\*Onsite services not included

\*\* Domes, lenses, lamps and batteries installed on Federal Signal products are specifically excluded

When Federal Signal has provided a turnkey installation including optimization and/or commissioning services, Federal Signal will provide onsite warranty service during the first 60-days after completion of the installation.



LIMITED WARRANTY — SCHEDULE OF PRODUCTS

Federal Signal Corporation – Signaling Division	
PRODUCT TYPE	WARRANTY PERIOD FOR PARTS REPAIR OR REPLACEMENT
<b>VISUAL SIGNALS</b>	
Battery Powered Lights	5 years parts and labor from date of delivery. Return to factory for service.
Incandescent Beacons	
LED Beacons	
Panel Mount Lights	
Status Indicators/Stack Lights	
Strobe Beacons	
<b>AUDIBLE DEVICES</b>	
Bells	5 years parts and labor from date of delivery. Return to factory for service.
Horns	
Intercoms (excludes Atkinson Dynamics®)	
Sirens (Model A, L, eSiren)	
Sounders	
Speakers	
<b>MISCELLANEOUS</b>	
Amplifiers	5 years parts and labor from date of delivery. Return to factory for service.
Audible/Visual Combination Signals	
Audible and Visual Accessories	
AudioMaster Products	
Audio Routers	
Extension Ringers	
Fire Alarms	
Initiating Devices	
Mounts and Brackets	
Power Supplies	
SelecTone® Tone Modules, Connector Kits, Controllers and Command Units	
<b>ATKINSON® DYNAMICS</b>	
Intercoms	2 years parts and labor from date of delivery. Return to factory for service.
Speakers	