

Title 106 ZONING DESIGNATIONS

CHAPTER 106.10. ESTABLISHMENT OF ZONES¹

106.10.010. Purpose.

The purpose of this chapter is to establish the zones and overlays that regulate physical development, use, development options, and subdivision. Zone and overlay standards are established in order to achieve the desired future land use articulated in the Comprehensive Plan. The zones are grouped into overlay districts, residential zones, nonresidential zones, and special purpose zones for organizational purposes.

(Ord. No. 823, § 9, 11-13-2012; Ord. No. 881, § 24, 9-26-2017)

106.10.020. Reserved.

Editor's note(s)—Ord. No. 881, § 25, adopted September 26, 2017, repealed § 106.10.020, which pertained to establishment of allowed land uses and derived from Ord. No. 823, § 9, 11-13-2012.

106.10.030. Reserved.

Editor's note(s)—Ord. No. 881, § 26, adopted September 26, 2017, repealed § 106.10.030, which pertained to organization and derived from Ord. No. 823, § 9, 11-13-2012.

106.10.040. Establishment of zones.

- A. Zoning boundaries are depicted on the city's official zoning map, which is hereby adopted by reference. The abbreviated zoning designations used in this title have the same meaning as the entire zoning district classification title and are meant to implement the Comprehensive Plan Future Land Use designations for the city.
- B. Individual water, on-site wastewater, public water and public wastewater availability help determine the zoning densities allowed within each of the established zones. When private water or sewerage facilities are sought within the community, the Thurston county health department is the jurisdiction with approval authority regarding ultimate lot size, which may require more land than is shown in Table 106.10.070-2. This decision is based on physical constraints of the land including proximity of individual water (if applicable) and area requirements for on-site waste systems.
- C. Notwithstanding any provisions in this title to the contrary, surveying the location of lot lines or setback lines at a development site and/or construction related thereto shall be the responsibility of the applicant/owner.

(Ord. No. 823, § 9, 11-13-2012)

¹Editor's note(s)—Ordinance No. 881, § 23, adopted September 26, 2017, renamed Chapter 106.10 to read as herein set out. Formerly, such chapter pertained to land use zones.

106.10.050. Zoning map.

- A. The location and boundaries of all zones or districts designated in this title are hereby established as shown on the map entitled, City of Tenino Official Zoning Map, as adopted herewith and as may be amended from time to time, and hereafter may be referred to as "the zoning map." The zoning map shall be as shown on a geographic coverage layer attributed to zoning that is maintained as a part of the city's geographic information system (GIS) under the supervision of the designee. No unauthorized person may alter or modify the zoning geographic information system layer without approval by the designee. This geographic coverage layer, and as amended from time to time, shall constitute the official zoning map for the city's zoning jurisdictions and shall be incorporated into this title by reference as if fully set forth herein. An original, signed copy of the zoning map containing the zoning districts designated at the time of adoption of this title shall be retained in the office of the city clerk pursuant to RCW 35.63.100, and duplicates shall be filed in the community development department for reference and public distribution. All amendments thereafter made to the zoning map shall be made by ordinance and shall be reflected on such map, and it shall be the responsibility of the community development department to ensure that an up-to-date map is maintained at all times.
- B. Where questions arise concerning the location of a district boundary, the designee shall interpret the zone boundaries as a Process I Land Use Action.

(Ord. No. 823, § 9, 11-13-2012)

106.10.060—106.10.080. Reserved.

Editor's note(s)—Ord. No. 881, §§ 27—29, adopted September 26, 2017, repealed § 106.10.060—106.10.080, which pertained to purpose of zoning districts; development standards for zoning districts; additional standards for West Tenino Zone and derived from Ord. No. 823, § 9, 11-13-2012; Ord. No. 829, § 1, 10-8-2013.

CHAPTER 106.20. OVERLAY DISTRICTS²

106.20.010. Historic preservation overlay (HP) district.

- A. The city has a designated historic preservation overlay zone that includes 21 properties with frontage on Sussex Avenue, and encompasses 2.99 acres. The historic preservation (HP) zone district is identified to encourage the preservation of lands, sites, and structures of historical or archaeological significance through continued use of these historic places and structures.
- B. Most of the properties within the HP overlay zone have been submitted for listing on the National Historic Register as historic properties. The current and underlying zoning (C-1) remains in effect, to include height, setbacks, density, and uses as allowed in Tables 106.10.070-1 and 106.10.70-2, except public facility permits

²Editor's note(s)—Ord. No. 823, § 10, adopted November 13, 2012, amended chapter 106.20 in its entirety to read as herein set out. Former chapter 106.20, §§ 106.20.010—106.20.130, pertained to land use zones, and derived from Ord. No. 710, 4-26-2004; Ord. No. 731, 2-13-2007; Ord. No. 754, § 17, 2-24-2009; Ord. No. 791, § 2, 3-8-2011; Ord. No. 801, §§ 5—20, 11-22-2011; Ord. No. 805, §§ 1, 2, 12-13-2011; Ord. No. 810, §§ 1, 2, 2-28-2012.

not allowed within this overlay district. Renovations or new building will require design review pursuant to this code, to preserve the historic buildings or structures.

(Ord. No. 823, § 10, 11-13-2012)

106.20.020. Historic character overlay (HC) zoning district.

- A. *Purpose.* The purpose of this district is to promote the city's sandstone heritage by requiring new commercial development in the downtown core to add sandstone to the exterior of its building and to encourage existing buildings to also add sandstone.
- B. *Focal point.* The downtown area is the focal point of the community, and contains most of the area's historic sandstone buildings. The downtown area includes retail and service oriented businesses and is characterized by historic sandstone buildings built in the early 1900s as well as newer development that includes sandstone facades on buildings.
- C. *Intent.* The intent of this zone is to highlight the city's sandstone heritage by requiring design review standards for all new commercial activities fronting the main arterials within this district. Design standards shall require the use of sandstone and/or brick to some degree pursuant to this code. Existing commercial business will be encouraged, but not required, to conform to the design character. The current and underlying zoning (C-1) remains in effect, to include height, setbacks, density and uses as allowed in Tables 106.10.070-1 and 106.10.070-2, except public facility permits not allowed within this overlay district.

(Ord. No. 823, § 10, 11-13-2012)

106.20.030. Professional office (PO) overlay zoning district.

- A. *Purpose.* The professional office overlay zone is meant to allow administrative and professional offices and private training school uses in addition to the uses allowed in the underlying zone. The goal of this overlay designation is to provide incentives for owners to rehabilitate existing older single-family homes in the area into uses that are not overly intrusive to other existing residential uses, while providing an additional means of economic development for the city.
- B. *Conformance with standards of underlying zone.* Uses and development standards of this overlay zone shall conform to the requirements of the underlying zoning district.
- C. *Additional permitted uses.* This overlay zone allows for the following office/business uses in addition to the uses allowed by the underlying zone:
 - 1. Administrative and professional offices within existing single-family or duplex units;
 - 2. Small private training schools, such as tutors, music teachers, or similar uses, within existing single-family or duplex units.

(Ord. No. 823, § 10, 11-13-2012)

CHAPTER 106.30 RESIDENTIAL ZONES

106.30.010. Single family-environmentally sensitive (SF-ES) zone.

- A. *Intent.* The single-family-environmentally sensitive zone requires special consideration of environmental constraints, thus typically requiring larger residential lots. This zoning district seeks to reduce potential

(Supp. No. 5)

Created: 2025-03-27 14:35:22 [EST]

impacts created by the built environment and any potential impact to the environment, while also considering any potential environmental consequences that may befall existing or permitted uses.

- B. *Physical development.* Standards applicable to physical development in the SF-ES zone are provided on the following pages. Where a cross-reference is listed, see the referenced title, chapter or section for additional standards.

<i>1. Setbacks (min)</i>		<i>Sec. 108.30.040</i>
Front:		20'
Garage/Carport:		20'
Side:		10'
Rear:		20'
<i>2. Impervious surfaces</i>		
Maximum		50%
<i>3. Building coverage</i>		
Maximum		n/a
<i>4. Design standards</i>		<i>Sec. 108.30.140</i>
Buildings		n/a
Lighting		n/a
Landscaping		
Parking lots		n/a
Street trees		n/a
Visual screening		n/a
<i>5. Fencing</i>		<i>Sec 108.30.040</i>
Height in any front yard (max)		4'
Height in any side yard (max)		6'
Height in any rear yard (max)		6'
<i>6. Building height</i>		<i>Sec. 108.30.040</i>
Maximum		35'
<i>7. Environmental standards</i>		
Shoreline development		Title 109
SEPA review		Title 110
Critical area buffers		Title 112
Wetlands		50'—300'
CARAs		Protect water source
Frequently flooded areas		50'
Geologically hazardous areas		slope ht.
Wildlife habitat		varies
<i>8. Signs</i>		<i>Sec. 108.30.130</i>
<i>9. Grading, erosion control, stormwater (reserved)</i>		
<i>10. Required physical development permits (reserved)</i>		

- C. *Allowed uses and use standards.* Standards applicable to use are provided in this subsection. Where a cross-reference is listed, see the referenced title, chapter, or section for additional standards. All standards in Title 106 and Title 108 are applicable unless stated otherwise.

<i>1. Allowed Uses</i>			<i>2. Parking (Ch. 108.50)</i>	
<i>Use</i>	<i>Definition/Standards</i>	<i>Permit</i>	<i>Minimum</i>	<i>Maximum</i>

<i>Open Space Uses</i>				
Agriculture	[108.40.030.B.]	Y	n/a	n/a
<i>Residential Uses</i>				
Detached Single-Family Unit	[108.40.040.B.]	Y	2 per DU	n/a
<i>Institutional Uses</i>				
Assembly	[108.40.060.B.]	C	Independent Calculation	
Emergency Services	[108.40.060.E.]	C	Independent Calculation	
<i>Amusement and Recreation</i>				
Outdoor Recreation	[108.40.080.C.]	Y	Independent Calculation	
Developed Recreation	[108.40.080.D.]	A	Independent Calculation	
<i>Transportation and Infrastructure Uses</i>				
Utility Facility	[108.40.100.C.]	C	1 per employee + 1 per stored vehicle	1 per employee + 1 per stored vehicle
Wireless Telecommunications Facility	See Sec. 108.40.100.E.		1 per employee + 1 per stored vehicle	1 per employee + 1 per stored vehicle
<i>Accessory Uses</i>				
Accessory Dwelling Unit	[108.40.110.B.]	A	1 per DU	2 per DU
Bed and Breakfast	[108.40.110.C.]	A	0.75 per LU	1.5 per LU
Home Occupation	[108.40.110.D.]	A	n/a	n/a
Home Business	[108.40.110.E.]	C	1 per employee	1 per employee
Home Daycare	[108.40.110.G.]	A	1 per employee	1 per employee
Battery Charging Station	[108.40.110.H.]	Y	n/a	n/a
<i>Temporary Uses</i>				
Yard Sale	[108.40.120.B.]	Y	n/a	n/a

Farm Stand	[108.40.120.D.]	Y	5 per 1,000 sf display area	5 per 1,000 sf display area
Temporary Real Estate Sales Office	[108.40.120.E.]	A	2	4
Temporary Shelter	[108.40.120.F.]	A	2 per DU	2 per DU
Temporary Gravel Processing	[108.40.120.G.]	A	1 per employee	1 per employee

Y = allowed without use permit A = Administrative Use Permit required C = Conditional Use Permit required PF = Public Facilities Use Permit required (PO) = Only allowed in the PO Overlay

<i>3. Performance standards</i>	
Outdoor Storage	(Sec. 108.60.020.)
Recreational Vehicles	Allowed if standards are met
Outdoor Storage Areas and Yards	Prohibited
Shipping Containers and Compartments	Allowed if standards are met
Refuse and Recycling	(Sec. 108.60.030.)
Trash and recycling enclosure required	>4 DUs and all nonresidential
Noise	(Sec. 108.60.040.)
Sound level at property line (max)	75 DBA
Vibration	(Sec. 108.60.050.)
Odors	(Sec. 108.60.060.)
Light and Glare	(Sec. 108.60.070.)
Radioactivity and Electrical Disturbances	(Sec. 108.60.080.)

D. *Lot standards.*

1. *Minimum lot size.*

- a. *Width:* 75 feet.
- b. *Depth:* 90 feet.
- c. *Area:* 10,890 square feet.

2. *Maximum residential density.* Residential density is calculated by dividing the number of dwelling units by the site area. The allowed density is generally based on the availability of a sewer system. Where sewer is not available, the city defers to the Thurston County Health Department to establish maximum densities.

- a. *Individual water and septic.* Defers to Thurston County standards.
- b. *Public water and individual septic.* Defers to Thurston County standards.
- c. *Public water and sewer.* 4 du/ac.

E. *Development options and subdivision.* (Reserved.)

F. *Additional zone-specific standards.*

(Ord. No. 881, § 30, 9-26-2017)

106.30.020. Single Family (SF) Zone.

- A. *Intent.* The single-family zone provides for larger residential lots in specific areas where a pattern of larger lots exists. This zone seeks to preserve the identity of these residential areas and reduce traffic volumes to provide safe, family-friendly areas.
- B. *Physical development.* Standards applicable to physical development in the SF zone are provided on the following pages. Where a cross-reference is listed, see the referenced title, chapter or section for additional standards.

<i>1. Setbacks (min)</i>	<i>Sec. 108.30.040.</i>
Front:	10'
Garage/Carport:	20'
Side:	5'
Rear:	20'
<i>2. Impervious Surfaces</i>	
Maximum	50%
<i>3. Building Coverage</i>	
Maximum	n/a
<i>4. Design Standards</i>	<i>Sec. 108.30.140.</i>
Buildings	n/a
Lighting	n/a
Landscaping	
Parking lots	n/a
Street trees	n/a
Visual screening	n/a
<i>5. Fencing</i>	<i>Sec 108.30.040.</i>
Height in any front yard (max)	4'
Height in any side yard (max)	6'
Height in any rear yard (max)	6'
<i>6. Building Height</i>	<i>Sec. 108.30.040.</i>
Maximum	35'
<i>7. Environmental Standards</i>	
Shoreline Development	Title 109
SEPA Review	Title 110
Critical Area Buffers	Title 112
Wetlands	50'—300'
CARAs	protect water source
Frequently Flooded Areas	50'
Geologically Hazardous Areas	slope ht.
Wildlife Habitat	varies
<i>8. Signs</i>	<i>Sec. 108.30.130.</i>
<i>9. Grading, Erosion Control, Stormwater (reserved)</i>	
<i>10. Required Physical Development Permits (reserved)</i>	

- C. *Allowed uses and use standards.* Standards applicable to use are provided in this subsection. Where a cross-reference is listed, see the referenced title, chapter, or section for additional standards. All standards in Title 106 and Title 108 are applicable unless stated otherwise.

<i>1. Allowed Uses</i>			<i>2. Parking (Ch. 108.50)</i>	
<i>Use</i>	<i>Definition/Standards</i>	<i>Permit</i>	<i>Minimum</i>	<i>Maximum</i>
<i>Residential Uses</i>				
Detached Single-Family Unit	[108.40.040.B.]	Y	2 per DU	n/a
<i>Institutional Uses</i>				
Assembly	[108.40.060.B.]	C	Independent Calculation	
Daycare Center	[108.40.060.C.]	C	0.5 per employee	1 per employee
School	[108.40.060.D.]	C	Independent Calculation	
Emergency Services	[108.40.060.E.]	C	Independent Calculation	
<i>Commercial Uses</i>				
Office	[108.40.070.B.]	A(PO)	1 per 1,000 sf	5.5 per 1,000 sf
<i>Amusement and Recreation</i>				
Outdoor Recreation	[108.40.080.C.]	Y	Independent Calculation	
Developed Recreation	[108.40.080.D.]	A	Independent Calculation	
<i>Transportation and Infrastructure Uses</i>				
Utility Facility	[108.40.100.C.]	C	1 per employee + 1 per stored vehicle	1 per employee + 1 per stored vehicle
Wireless Telecommunications Facility	See Sec. [108.40.100.E.]		1 per employee + 1 per stored vehicle	1 per employee + 1 per stored vehicle
<i>Accessory Uses</i>				
Accessory Dwelling Unit	[108.40.110.B.]	A	1 per DU	2 per DU
Bed and Breakfast	[108.40.110.C.]	C	0.75 per LU	1.5 per LU
Home Occupation	[108.40.110.D.]	A	n/a	n/a

Home Business	[108.40.110.E.]	C	1 per employee	1 per employee
Home Daycare	[108.40.110.G.]	A	1 per employee	1 per employee
Battery Charging Station	[108.40.110.H.]	Y	n/a	n/a
<i>Temporary Uses</i>				
Yard Sale	[108.40.120.B.]	Y	n/a	n/a
Farm Stand	[108.40.120.D.]	Y	5 per 1,000 sf display area	5 per 1,000 sf display area
Temporary Real Estate Sales Office	[108.40.120.E.]	A	2	4
Temporary Shelter	[108.40.120.F.]	A	2 per DU	2 per DU
Temporary Gravel Processing	[108.40.120.G.]	A	1 per employee	1 per employee
Y = allowed without use permit A = Administrative Use Permit required C = Conditional Use Permit required PF = Public Facilities Use Permit required (PO) = Only allowed in the PO Overlay				

<i>3. Performance Standards</i>	
Outdoor Storage	(Sec. 108.60.020.)
Recreational Vehicles	allowed if standards are met
Outdoor Storage Areas and Yards	Prohibited
Shipping Containers and Compartments	allowed if standards are met
Refuse and Recycling	(Sec. 108.60.030.)
Trash and recycling enclosure required	>4 DUs and all nonresidential
Noise	(Sec. 108.60.040.)
Sound level at property line (max)	75 DBA
Vibration	(Sec. 108.60.050.)
Odors	(Sec. 108.60.060.)
Light and Glare	(Sec. 108.60.070.)
Radioactivity and Electrical Disturbances	(Sec. 108.60.080.)

D. *Lot standards.*

1. *Minimum lot size.*
 - a. *Width:* 50 feet.
 - b. *Depth:* 75 feet.
 - c. *Area:* 5,445 square feet.

- 2. *Maximum residential density.* Residential density is calculated by dividing the number of dwelling units by the site area. The allowed density is generally based on the availability of a sewer system. Where sewer is not available, the city defers to the Thurston County Health Department to establish maximum densities.
 - a. *Individual water and septic:* Defers to Thurston County standards.
 - b. *Public water and individual septic:* Defers to Thurston County standards.
 - c. *Public water and sewer:* 8 du/ac.
- E. *Development options and subdivision.* (Reserved).
- F. *Additional zone-specific standards.*
 - 1. *Battery Charging Stations.* Battery charging stations that require a 60 amp or higher dedicated breaker on a 480-volt or higher three-phase circuit with special grounding equipment are not allowed.

(Ord. No. 881, § 30, 9-26-2017)

106.30.030. Single-family/duplex (SFD) zone.

- A. *Intent.* The single-family/duplex zone is the city's primary residential zone, which provides for single-family and duplex dwellings in established residential neighborhoods.
- B. *Physical development.* Standards applicable to physical development in the SFD zone are provided on the following pages. Where a cross-reference is listed, see the referenced title, chapter or section for additional standards.

1. Setbacks (min)	<i>Sec. 108.30.040.</i>
Front:	10'
Duplex:	15'
Garage/Carport:	20'
Side:	5'
Rear:	10'
2. Impervious Surfaces	
Maximum	50%
3. Building Coverage	
Maximum	n/a
4. Design Standards	<i>Sec. 108.30.140.</i>
Buildings	n/a
Lighting	n/a
Landscaping	
Parking lots	n/a
Street trees	n/a
Visual screening	n/a
5. Fencing	<i>Sec 108.30.040.</i>
Height in any front yard (max)	4'
Height in any side yard (max)	6'
Height in any rear yard (max)	6'
6. Building Height	<i>Sec. 108.30.040.</i>
Maximum	35'

7. Environmental Standards	
Shoreline Development	Title 109
SEPA Review	Title 110
Critical Area Buffers	Title 112
Wetlands	50'—300'
CARAs	protect water source
Frequently Flooded Areas	50'
Geologically Hazardous Areas	slope ht.
Wildlife Habitat	varies
8. Signs	
9. Grading, Erosion Control, Stormwater (reserved)	
10. Required Physical Development Permits (reserved)	

- C. *Allowed uses and use standards.* Standards applicable to use are provided in this subsection. Where a cross-reference is listed, see the referenced title, chapter, or section for additional standards. All standards in Title 106 and Title 108 are applicable unless stated otherwise.

1. Allowed Uses			2. Parking (Ch. 108.50)	
Use	Definition/Standards	Permit	Minimum	Maximum
Residential Uses				
Detached Single-Family Unit	[108.40.040.B.]	Y	2 per DU	n/a
Duplex	[108.40.040.C.]	Y	2 per DU	n/a
Institutional Uses				
Assembly	[108.40.060.B.]	C	Independent Calculation	
Daycare Center	[108.40.060.C.]	C	0.5 per employee	1 per employee
School	[108.40.060.D.]	C	Independent Calculation	
Emergency Services	[108.40.060.E.]	C	Independent Calculation	
Amusement and Recreation				
Outdoor Recreation	[108.40.080.C.]	Y	Independent Calculation	
Developed Recreation	[108.40.080.D.]	A	Independent Calculation	
Transportation and Infrastructure Uses				
Utility Facility	[108.40.100.C.]	C	1 per employee + 1 per stored vehicle	1 per employee + 1 per stored vehicle

Wireless Telecommunications Facility	See Sec. 108.40.100.E.		1 per employee + 1 per stored vehicle	1 per employee + 1 per stored vehicle
<i>Accessory Uses</i>				
Accessory Dwelling Unit	[108.40.110.B.]	A	1 per DU	2 per DU
Bed and Breakfast	[108.40.110.C.]	C	0.75 per LU	1.5 per LU
Home Occupation	[108.40.110.D.]	A	n/a	n/a
Home Business	[108.40.110.E.]	C	1 per employee	1 per employee
Home Daycare	[108.40.110.G.]	A	1 per employee	1 per employee
Battery Charging Station	[108.40.110.H.] [subsection F.1.]	Y	n/a	n/a
<i>Temporary Uses</i>				
Yard Sale	[108.40.120.B.]	Y	n/a	n/a
Farm Stand	[108.40.120.D.]	Y	5 per 1,000 sf display area	5 per 1,000 sf display area
Temporary Real Estate Sales Office	[108.40.120.E.]	A	2	4
Temporary Shelter	[108.40.120.F.]	A	2 per DU	2 per DU
Temporary Gravel Processing	[108.40.120.G.]	A	1 per employee	1 per employee
Y = allowed without use permit A = Administrative Use Permit required C = Conditional Use Permit required PF = Public Facilities Use Permit required (PO) = Only allowed in the PO Overlay				

<i>3. Performance Standards</i>	
Outdoor Storage	(Sec. 108.60.020.)
Recreational Vehicles	allowed if standards are met
Outdoor Storage Areas and Yards	Prohibited
Shipping Containers and Compartments	allowed if standards are met
Refuse and Recycling	(Sec. 108.60.030.)
Trash and recycling enclosure required	>4 DUs and all nonresidential
Noise	(Sec. 108.60.040.)
Sound level at property line (max)	75 DBA
Vibration	(Sec. 108.60.050.)
Odors	(Sec. 108.60.060.)

Light and Glare	(Sec. 108.60.070.)
Radioactivity and Electrical Disturbances	(Sec. 108.60.080.)

D. *Lot standards.*

1. *Minimum lot size.*

- a. *Width:* 50 feet.
- b. *Depth:* 60 feet.
- c. *Area:* 5,445 square feet.

2. *Maximum residential density.* Residential density is calculated by dividing the number of dwelling units by the site area. The allowed density is generally based on the availability of a sewer system. Where sewer is not available, the city defers to the Thurston County Health Department to establish maximum densities.

- a. *Individual water and septic:* Defers to Thurston County standards.
- b. *Public water and individual septic:* Defers to Thurston County standards.
- c. *Public water and sewer:* 15 du/ac.

E. *Development options and subdivision.* (Reserved).

F. *Additional zone-specific standards.*

- 1. *Battery charging stations.* Battery charging stations that require a 60 amp or higher dedicated breaker on a 480-volt or higher three-phase circuit with special grounding equipment are not allowed.

(Ord. No. 881, § 30, 9-26-2017)

106.30.040. Multi-family residential (MF) zone.

A. *Intent.* The purpose of the multi-family residential zone is to promote small-lot detached dwellings and attached structures, such as apartments, condominiums and townhouses. This mix of housing may take a variety of forms, either mixed within a single site or mixed within a general area.

B. *Physical development.* Standards applicable to physical development in the SFD zone are provided on the following pages. Where a cross-reference is listed, see the referenced title, chapter or section for additional standards.

<i>1. Setbacks (min)</i>	<i>Sec. 108.30.040</i>
Front:	10'
Garage/Carport:	20'
Side:	5'
Rear:	10'
<i>2. Impervious Surfaces</i>	
Maximum	60%
<i>3. Building Coverage</i>	
Maximum	n/a
<i>4. Design Standards</i>	<i>Sec. 108.30.140</i>
Buildings	Sec. 108.30.140
Lighting	90° cut-off angle required

Landscaping	
Parking lots	1 tree per 2,000 sf
Street trees	required
Visual screening	between uses
5. Fencing	
Height in any front yard (max)	4'
Height in any side yard (max)	6'
Height in any rear yard (max)	6'
6. Building Height	
Maximum	35'
7. Environmental Standards	
Shoreline Development	Title 109
SEPA Review	Title 110
Critical Area Buffers	Title 112
Wetlands	50'—300'
CARAs	protect water source
Frequently Flooded Areas	50'
Geologically Hazardous Areas	slope ht.
Wildlife Habitat	varies
8. Signs	
9. Grading, Erosion Control, Stormwater (reserved)	
10. Required Physical Development Permits (reserved)	

- C. *Allowed uses and use standards.* Standards applicable to use are provided in this subsection. Where a cross-reference is listed, see the referenced title, chapter, or section for additional standards. All standards in Title 106 and Title 108 are applicable unless stated otherwise.

1. Allowed Uses			2. Parking (Ch. 108.50)	
Use	Definition/Standards	Permit	Minimum	Maximum
<i>Residential Uses</i>				
Detached Single-Family Unit	[108.40.040.B.]	Y	2 per DU	n/a
Duplex	[108.40.040.C.]	Y	2 per DU	n/a
Attached Single-Family Unit	[108.40.040.D.] [subsection F.1]	Y	1.5 per DU	2 per DU
Group Home	[108.40.040.E.]	Y	0.5 per bed	1.5 per bed
<i>Institutional Uses</i>				
Assembly	[108.40.060.B.]	C	Independent Calculation	
Daycare Center	[108.40.060.C.]	A	0.5 per employee	1 per employee
School	[108.40.060.D.]	C	Independent Calculation	
Emergency Services	[108.40.060.E.]	C	Independent Calculation	

<i>Commercial Uses</i>				
Office	[108.40.070.B.]	A	1.5 per 1,000 sf	4 per 1,000 sf
<i>Amusement and Recreation</i>				
Outdoor Recreation	[108.40.080.C.]	Y	Independent Calculation	
Developed Recreation	[108.40.080.D.]	A	Independent Calculation	
<i>Transportation and Infrastructure Uses</i>				
Utility Facility	[108.40.100.C.]	C	1 per employee + 1 per stored vehicle	1 per employee + 1 per stored vehicle
Wireless Telecommunications Facility	See Sec. 108.40.100.E.		1 per employee + 1 per stored vehicle	1 per employee + 1 per stored vehicle
<i>Accessory Uses</i>				
Accessory Dwelling Unit	[108.40.110.B.]	A	1 per DU	2 per DU
Bed and Breakfast	[108.40.110.C.]	Y	0.75 per LU	1.5 per LU
Home Occupation	[108.40.110.D.]	A	n/a	n/a
Home Business	[108.40.110.E.]	C	1 per employee	1 per employee
Home Daycare	[108.40.110.G.]	A	1 per employee	1 per employee
Battery Charging Station	[108.40.110.H.] [subsection F.2.]	Y	n/a	n/a
<i>Temporary Uses</i>				
Yard Sale	[108.40.120.B.]	Y	n/a	n/a
Farm Stand	[108.40.120.D.]	Y	5 per 1,000 sf display area	5 per 1,000 sf display area
Temporary Real Estate Sales Office	[108.40.120.E.]	A	2	4
Temporary Shelter	[108.40.120.F.]	A	2 per DU	2 per DU
Temporary Gravel Processing	[108.40.120.G.]	A	1 per employee	1 per employee

Y = allowed without use permit A = Administrative Use Permit required C = Conditional Use Permit required
 PF = Public Facilities Use Permit required (PO) = Only allowed in the PO Overlay

3. Performance Standards	
Outdoor Storage	(Sec. 108.60.020.)
Recreational Vehicles	allowed if standards are met
Outdoor Storage Areas and Yards	Prohibited
Shipping Containers and Compartments	allowed if standards are met
Refuse and Recycling	(Sec. 108.60.030.)
Trash and recycling enclosure required	>4 DUs and all nonresidential
Noise	(Sec. 108.60.040.)
Sound level at property line (max)	75 DBA
Vibration	(Sec. 108.60.050.)
Odors	(Sec. 108.60.060.)
Light and Glare	(Sec. 108.60.070.)
Radioactivity and Electrical Disturbances	(Sec. 108.60.080.)

D. *Lot standards.*

1. *Minimum lot size.*

- a. *Width:* 20 feet.
- b. *Depth:* 55 feet.

2. *Maximum residential density.* Residential density is calculated by dividing the number of dwelling units by the site area. The allowed density is generally based on the availability of a sewer system. Where sewer is not available, the city defers to the Thurston County Health Department to establish maximum densities.

- a. *Individual water and septic:* Defers to Thurston County standards.
- b. *Public water and individual septic:* Defers to Thurston County standards.
- c. *Public water and sewer:* 40 du/ac.

E. *Development options and subdivision.* (Reserved).

F. *Additional zone-specific standards.*

- 1. *Attached single-family dwellings.* The side yard setback may be reduced to zero feet when a row of townhouses or other attached dwelling units are constructed on different lots as part of the same development.

(Ord. No. 881, § 30, 9-26-2017)

CHAPTER 106.40. NONRESIDENTIAL ZONES

106.40.010. Commercial 1 (C1) zone.

- A. *Intent.* The commercial 1 zone encompasses the area in and around historic downtown Tenino and is meant to build on the historic and walkable nature of the area. Buildings are meant to be comprised of a high-quality design that compliments the historic architecture of the area, and storefronts are meant to contribute to the creation of a walkable business district, with features such as awnings, large windows and attractive window displays that help to encourage pedestrian exploration and purchasing within the area. Retail, service and certain craft uses, which generate significant pedestrian traffic, are meant to occupy bottom floors of buildings, while offices, services, and residences with lesser turnover are intended to be situated in upper stories or towards the back of structures. Buildings are meant to be set at or near the front property line to help define the walkable, pedestrian-oriented street front, and parking is intended to be located on the street, in shared parking facilities, or behind the structures.

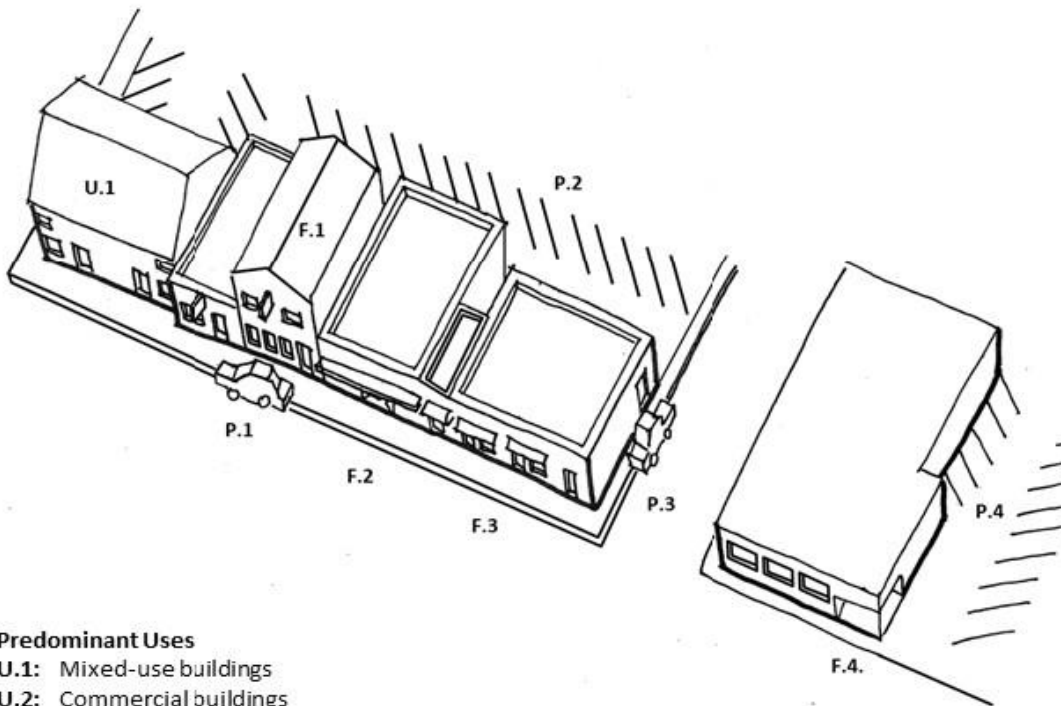

Predominant Uses

- U.1: Mixed-use buildings
- U.2: Commercial buildings

Predominant Form Characteristics

- F.1: New buildings designed to compliment scale of neighboring structures
- F.2: Pedestrian-oriented design features (high degree of windows on ground floor, doors facing the street, weather protection features such as awnings)
- F.3: Buildings set at front property line or at same setback as neighboring structures, and built to the side property line
- F.4: Doors oriented to both street and side parking area, when side parking lot is utilized

Parking Arrangements

- P.1: On-street parking
- P.2: Alley-accessed parking behind building
- P.3: Parking on side streets
- P.4: Side parking lot (allowed but not encouraged)

B. *Physical development.* Standards applicable to physical development in the C1 zone are provided on the following pages. Where a cross-reference is listed, see the referenced title, chapter or section for additional standards.

1. Setbacks (min)		<i>Sec. 108.30.040</i>
Front:		0'
Garage/Carport:		0'
Side:		0'
Rear:		0'
2. Impervious Surfaces		
Maximum		100%
3. Building Coverage		
Maximum		n/a
4. Design Standards		<i>Sec. 108.30.140</i>
Buildings		<i>Sec. 108.30.140</i>
Lighting		90° cut-off angle required
Landscaping		
Parking lots		1 tree per 2,000 sf
Street trees		required
Visual screening		between uses
5. Fencing		<i>Sec 108.30.040</i>
Height in any front yard (max)		4'
Height in any side yard (max)		6'
Height in any rear yard (max)		6'
6. Building Height		<i>Sec. 108.30.040</i>
Maximum		35'
7. Environmental Standards		
Shoreline Development		Title 109
SEPA Review		Title 110
Critical Area Buffers		Title 112
Wetlands		50'—300'
CARAs		protect water source
Frequently Flooded Areas		50'
Geologically Hazardous Areas		slope ht.
Wildlife Habitat		varies
8. Signs		<i>Sec. 108.30.130</i>
9. Grading, Erosion Control, Stormwater (reserved)		
10. Required Physical Development Permits (reserved)		

C. *Allowed Uses and Use Standards.* Standards applicable to use are provided in this subsection. Where a cross-reference is listed, see the referenced title, chapter, or section for additional standards. All standards in Title 106 and Title 108 are applicable unless stated otherwise.

1. Allowed Uses			2. Parking (Ch. 108.50)	
<i>Use</i>	<i>Definition/Standards</i>	<i>Permit</i>	<i>Minimum</i>	<i>Maximum</i>
<i>Residential Uses</i>				

Attached Single-Family Unit	[108.40.040.D.] [106.40.010.F.1]	A	1.5 per DU	2 per DU
Group Home	[108.40.040.E.] [106.40.010.F.1.]	A	0.5 per bed	1.5 per bed
<i>Lodging Uses</i>				
Conventional Lodging	[108.40.050.B.] [106.40.010.F.2]	Y	0.6 per LU	2 per LU
<i>Institutional Uses</i>				
Assembly	[108.40.060.B.]	Y	Independent Calculation	
Daycare Center	[108.40.060.C.]	Y	0.5 per employee	1 per employee
Emergency Services	[108.40.060.E.]	A	Independent Calculation	
<i>Commercial Uses</i>				
Office	[108.40.070.B.]	Y	1 per 1,000 sf	4 per 1,000 sf
Retail	[108.40.070.C.]	Y	3 per 1,000 sf	6 per 1,000 sf
Service	[108.40.070.D.]	Y	2 per 1,000 sf	4 per 1,000 sf
Restaurant/Bar	[108.40.070.E.]	Y	5 per 1,000 sf	20 per 1,000 sf
Mobile Food Vendor	[108.40.070.F.]	A	Independent Calculation	
Heavy Retail/Service	[108.40.070.G.]	A	2 per 1,000 sf + 3 per repair bay + 1 per wash bay	6 per 1,000 sf + 3 per repair bay + 1 per wash bay
Nursery	[108.40.070.I.]	A	2 per 1,000 sf + 1 per 4,000 sf outdoor display area + 1 per employee	2 per 1,000 sf + 1 per 4,000 sf outdoor display area + 1 per employee
Battery Exchange Station	[108.40.070.J.]	C	Independent Calculation	
Marijuana Business	[108.40.070.K.]	A	3 per 1,000 sf	6 per 1,000 sf
<i>Amusement and Recreation</i>				
Amusement	[108.40.080.B.]	A	3 per 1,000 sf	5 per 1,000 sf

Outdoor Recreation	[108.40.080.C.]	Y	Independent Calculation	
Developed Recreation	[108.40.080.D.]	Y	Independent Calculation	
<i>Industrial Uses</i>				
Craft Food Production	[108.40.090.B.]	A	Independent Calculation	
Light Industry	[108.40.090.C.]	C	0.5 per employee + 1 per company vehicle	1 per employee + 1 per company vehicle
<i>Transportation and Infrastructure Uses</i>				
Parking	[108.40.100.B.]	A	n/a	n/a
Utility Facility	[108.40.100.C.]	C	1 per employee + 1 per stored vehicle	1 per employee + 1 per stored vehicle
Wireless Telecommunications Facility	See Sec. 108.40.100.E.		1 per employee + 1 per stored vehicle	1 per employee + 1 per stored vehicle
<i>Accessory Uses</i>				
Bed and Breakfast	[108.40.110.C.]	Y	0.75 per LU	1.5 per LU
Home Occupation	[108.40.110.D.]	Y	n/a	n/a
Home Business	[108.40.110.E.]	A	1 per employee	1 per employee
Drive-Up Facility	[108.40.110.F.]	C	n/a	n/a
Home Daycare	[108.40.110.G.]	A	1 per employee	1 per employee
Battery Charging Station	[108.40.110.H.]	Y	n/a	n/a
<i>Temporary Uses</i>				
Yard Sale	[108.40.120.B.]	Y	n/a	n/a
Christmas Tree Sales	[108.40.120.C.]	Y	1 per 1,000 sf outdoor display area +	1 per 1,000 sf outdoor display area +

			1 per employee	1 per employee
Farm Stand	[108.40.120.D.]	Y	5 per 1,000 sf display area	5 per 1,000 sf display area
Temporary Real Estate Sales Office	[108.40.120.E.]	A	2	4
Temporary Shelter	[108.40.120.F.]	A	2 per DU	2 per DU
Temporary Gravel Processing	[108.40.120.G.]	A	1 per employee	1 per employee
Y = allowed without use permit A = Administrative Use Permit required C = Conditional Use Permit required PF = Public Facilities Use Permit required (PO) = Only allowed in the PO Overlay				

3. Performance Standards	
Outdoor Storage	(Sec. 108.60.020)
Recreational Vehicles	allowed if standards are met
Outdoor Storage Areas and Yards	allowed if standards are met
Shipping Containers and Compartments	allowed if standards are met
Refuse and Recycling	(Sec. 108.60.030)
Trash and recycling enclosure required	>4 DUs and all nonresidential
Noise	(Sec. 108.60.040)
Sound level at property line (max)	75 DBA
Vibration	(Sec. 108.60.050)
Odors	(Sec. 108.60.060)
Light and Glare	(Sec. 108.60.070)
Radioactivity and Electrical Disturbances	(Sec. 108.60.080)

D. *Lot standards.*

1. *Minimum lot size.*

- a. *Width:* 20 feet.
- b. *Depth:* 24 feet.

2. *Maximum residential density.* Residential density is calculated by dividing the number of dwelling units by the site area. The allowed density is generally based on the availability of a sewer system. Where sewer is not available, the city defers to the Thurston County Health Department to establish maximum densities.

- a. *Individual water and septic:* Defers to Thurston County standards.
- b. *Public water and individual septic:* Defers to Thurston County standards.
- c. *Public water and sewer:* 40 du/ac.

E. *Development Options and Subdivision.* (Reserved).

F. *Additional zone-specific standards.*

1. *Residential uses.* Residential uses may only be allowed as part of a mixed-use development and must not be located on the ground floor.
2. *Conventional lodging.* Conventional lodging may only be allowed as part of a mixed-use development.
3. *On-street parking.* Required parking may be provided on-street provided the following standards are met.
 - a. An on-street parking space shall have the following length of uninterrupted curb adjoining to the lot of record of the proposed use.

Uninterrupted Curb Per On-Street Parking Space	
Parking Space Angle	Uninterrupted Curb
Parallel	22'
45°/60°	20'
90°	9'

- b. On-street parking shall not be provided along a yellow curb or other no parking areas put in place by the City or WSDOT.
- c. The on-street parking shall follow the established configuration of existing on-street parking.
- d. On-street parking spaces shall be available for use by the public at all times. Signs or actions limiting public use of on-street spaces are prohibited.

(Ord. No. 881, § 31, 9-26-2017)

106.40.020. Commercial 2 (C2) zone.

- A. *Intent.* The commercial 2 zone is located at entrances to the community and at major community intersections. The zone is meant to accommodate primarily commercial uses, such as retail and service uses, though some dwellings in upper stories of structures are appropriate if desired. The zone is meant to be targeted primarily to passing motorists, though some individuals will walk to the area. Parking is meant to be located on-site.

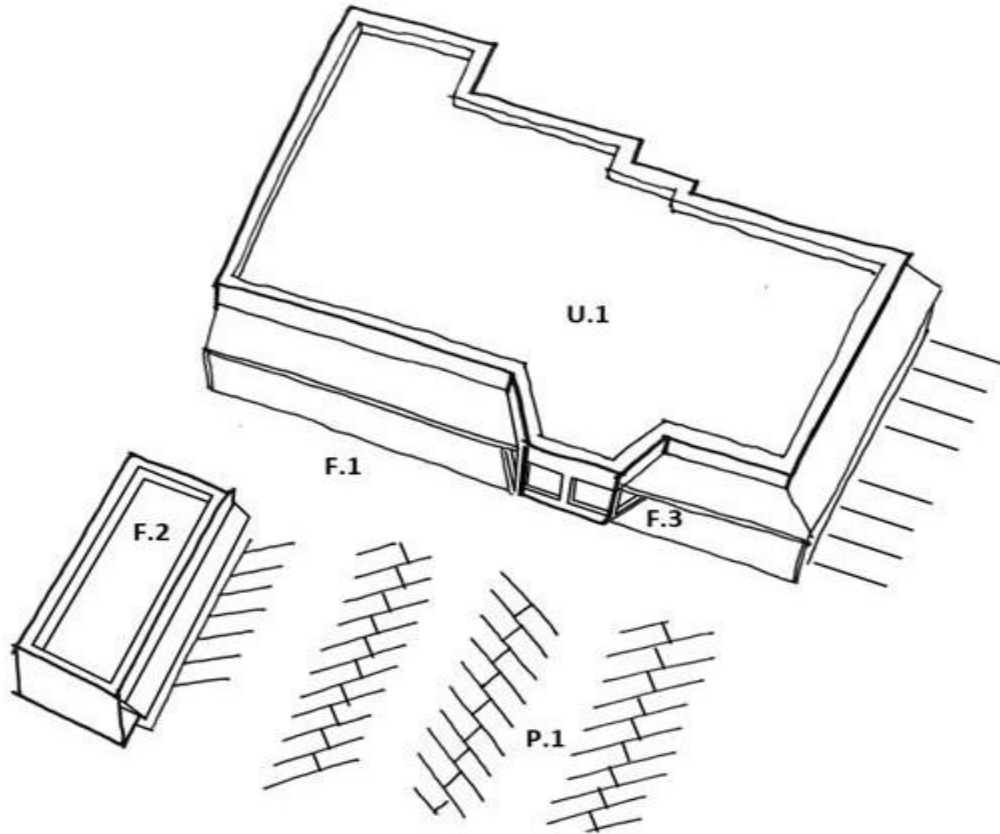

Predominant Uses

U.1: Auto-oriented commercial buildings (and possibly mixed-use buildings)

Predominant Form Characteristics

F.1: Buildings oriented to automobile traffic, though features to promote walking also included

F.2: Buildings set either near the front property line or back from the street

F.3: Doors oriented to parking lot

Parking Arrangements

P.1: On-site parking (either between buildings and street or inside parcel)

B. *Physical development.* Standards applicable to physical development in the C2 zone are provided on the following pages. Where a cross-reference is listed, see the referenced title, chapter or section for additional standards.

1. Setbacks (min)	<i>Sec. 108.30.040</i>
Front:	0'
Garage/Carport:	0'
Side:	0'
Rear:	0'
2. Impervious Surfaces	
Maximum	100%
3. Building Coverage	
Maximum	n/a
4. Design Standards	<i>Sec. 108.30.140</i>

Buildings	Sec. 108.30.140
Lighting	90° cut-off angle required
Landscaping	
Parking lots	1 tree per 2,000 sf
Street trees	required
Visual screening	between uses
5. <i>Fencing</i>	<i>Sec. 108.30.040</i>
Height in any front yard (max)	4'
Height in any side yard (max)	6'
Height in any rear yard (max)	6'
6. <i>Building Height</i>	<i>Sec. 108.30.040</i>
Maximum	35'
7. <i>Environmental Standards</i>	
Shoreline Development	Title 109
SEPA Review	Title 110
Critical Area Buffers	Title 112
Wetlands	50'—300'
CARAs	protect water source
Frequently Flooded Areas	50'
Geologically Hazardous Areas	slope ht.
Wildlife Habitat	varies
8. <i>Signs</i>	<i>Sec. 108.30.130</i>
9. <i>Grading, Erosion Control, Stormwater (reserved)</i>	
10. <i>Required Physical Development Permits (reserved)</i>	

- C. *Allowed uses and use standards.* Standards applicable to use are provided in this subsection. Where a cross-reference is listed, see the referenced title, chapter, or section for additional standards. All standards in Title 106 and Title 108 are applicable unless stated otherwise.

1. <i>Allowed Uses</i>			2. <i>Parking (Ch. 108.50)</i>	
<i>Use</i>	<i>Definition/Standards</i>	<i>Permit</i>	<i>Minimum</i>	<i>Maximum</i>
<i>Residential Uses</i>				
Attached Single-Family Unit	[108.40.040.D.] [106.40.020.F.1]	A	1.5 per DU	2 per DU
Group Home	[108.40.040.E.] [106.40.020.F.1]	A	0.5 per bed	1.5 per bed
Correctional Group Home	[108.40.040.F.] [106.40.020.F.1]	PF	0.5 per bed	1.5 per bed
<i>Lodging Uses</i>				
Conventional Lodging	[108.40.050.B.]	Y	0.6 per LU	2 per LU
<i>Institutional Uses</i>				
Assembly	[108.40.060.B.]	Y	Independent Calculation	

Daycare Center	[108.40.060.C.]	Y	0.5 per employee	1 per employee
School	[108.40.060.D.]	C	Independent Calculation	
Emergency Services	[108.40.060.E.]	A	Independent Calculation	
<i>Commercial Uses</i>				
Office	[108.40.070.B.]	Y	1.5 per 1,000 sf	4 per 1,000 sf
Retail	[108.40.070.C.]	Y	3 per 1,000 sf	6 per 1,000 sf
Service	[108.40.070.D.]	Y	2 per 1,000 sf	4 per 1,000 sf
Restaurant/Bar	[108.40.070.E.]	Y	5 per 1,000 sf	20 per 1,000 sf
Mobile Food Vendor	[108.40.070.F.]	A	Independent Calculation	
Heavy Retail/Service	[108.40.070.G.]	A	2 per 1,000 sf + 3 per repair bay + 1 per wash bay	6 per 1,000 sf + 3 per repair bay + 1 per wash bay
Nursery	[108.40.070.I.]	A	2 per 1,000 sf + 1 per 4,000 sf outdoor display area + 1 per employee	2 per 1,000 sf + 1 per 4,000 sf outdoor display area + 1 per employee
Battery Exchange Station	[108.40.070.J.]	A	Independent Calculation	
Marijuana Business	[108.40.070.K.]	A	3 per 1,000 sf	6 per 1,000 sf
<i>Amusement and Recreation</i>				
Amusement	[108.40.080.B.]	A	3 per 1,000 sf	5 per 1,000 sf
Outdoor Recreation	[108.40.080.C.]	Y	Independent Calculation	
Developed Recreation	[108.40.080.D.]	Y	Independent Calculation	
<i>Industrial Uses</i>				
Craft Food Production	[108.40.090.B.]	A	Independent Calculation	

Light Industry	[108.40.090.C.]	A	0.5 per employee + 1 per company vehicle	1 per employee + 1 per company vehicle
<i>Transportation and Infrastructure Uses</i>				
Parking	[108.40.100.B.]	A	n/a	n/a
Utility Facility	[108.40.100.C.]	C	1 per employee + 1 per stored vehicle	1 per employee + 1 per stored vehicle
Wireless Telecommunications Facility	See Sec. 108.40.100.E.		1 per employee + 1 per stored vehicle	1 per employee + 1 per stored vehicle
<i>Accessory Uses</i>				
Bed and Breakfast	[108.40.110.C.]	Y	0.75 per LU	1.5 per LU
Home Occupation	[108.40.110.D.]	Y	n/a	n/a
Home Business	[108.40.110.E.]	A	1 per employee	1 per employee
Drive-Up Facility	[108.40.110.F.]	Y	n/a	n/a
Home Daycare	[108.40.110.G.]	A	1 per employee	1 per employee
Battery Charging Station	[108.40.110.H.] [Subsection F.1.]	Y	n/a	n/a
<i>Temporary Uses</i>				
Yard Sale	[108.40.120.B.]	Y	n/a	n/a
Christmas Tree Sales	[108.40.120.C.]	Y	1 per 1,000 sf outdoor display area + 1 per employee	1 per 1,000 sf outdoor display area + 1 per employee
Farm Stand	[108.40.120.D.]	Y	5 per 1,000 sf display area	5 per 1,000 sf display area
Temporary Real Estate Sales Office	[108.40.120.E.]	A	2	4
Temporary Shelter	[108.40.120.F.]	A	2 per DU	2 per DU

Temporary Gravel Processing	[108.40.120.G.]	A	1 per employee	1 per employee
Y = allowed without use permit A = Administrative Use Permit required C = Conditional Use Permit required PF = Public Facilities Use Permit required (PO) = Only allowed in the PO Overlay				

<i>3. Performance Standards</i>	
Outdoor Storage	(Sec. 108.60.020)
Recreational Vehicles	allowed if standards are met
Outdoor Storage Areas and Yards	allowed if standards are met
Shipping Containers and Compartments	allowed if standards are met
Refuse and Recycling	(Sec. 108.60.030)
Trash and recycling enclosure required	>4 DUs and all nonresidential
Noise	(Sec. 108.60.040)
Sound level at property line (max)	75 DBA
Vibration	(Sec. 108.60.050)
Odors	(Sec. 108.60.060)
Light and Glare	(Sec. 108.60.070)
Radioactivity and Electrical Disturbances	(Sec. 108.60.080)

D. *Lot standards.*

1. *Minimum lot size.*

a. *Width:* 20 feet.

2. *Maximum residential density.* Residential density is calculated by dividing the number of dwelling units by the site area. The allowed density is generally based on the availability of a sewer system. Where sewer is not available, the city defers to the Thurston County Health Department to establish maximum densities.

a. *Individual water and septic:* Defers to Thurston County standards.

b. *Public water and individual septic:* Defers to Thurston County standards.

c. *Public water and sewer.* 40 du/ac.

E. *Development options and subdivision.* (Reserved).

F. *Additional zone-specific standards.*

1. *Residential uses.* Residential uses may only be allowed as part of a mixed-use development and must not be located on the ground floor.

2. *On-street parking.* Required parking may be provided on-street provided the following standards are met.

a. An on-street parking space shall have the following length of uninterrupted curb adjoining to the lot of record of the proposed use.

Uninterrupted Curb Per On-Street Parking Space	
Parking Space Angle	Uninterrupted Curb

Parallel	22'
45°/60°	20'
90°	9'

- b. On-street parking shall not be provided along a yellow curb or other no parking areas put in place by the City or WSDOT.
- c. The on-street parking shall follow the established configuration of existing on-street parking.
- d. On-street parking spaces shall be available for use by the public at all times. Signs or actions limiting public use of on-street spaces are prohibited.

(Ord. No. 881, § 31, 9-26-2017)

106.40.030. Commercial 3 (C3) zone.

- A. *Intent.* The commercial 3 zone is located along major corridors within the community, and near the historic downtown of Tenino. The zone currently has a mix of existing single-family uses, new and existing multifamily buildings, mixed-use structures, and commercial uses, and is meant to allow this diversity and mix of uses as the area transitions in the future. The area allows existing single-family homes to continue as a conforming use, and permits new uses such as multifamily residential, commercial and some industrial activities. Buildings within the zone are meant to be set back from the street to some degree, to respect the design of the existing structures within the area, though some existing uses that are set on or near the street are not meant to be non-conforming. Parking is intended to be provided on site (preferably in the back of the building and accessed by an alley or on the side of the building) to maintain the appearance of a street front lined with buildings.

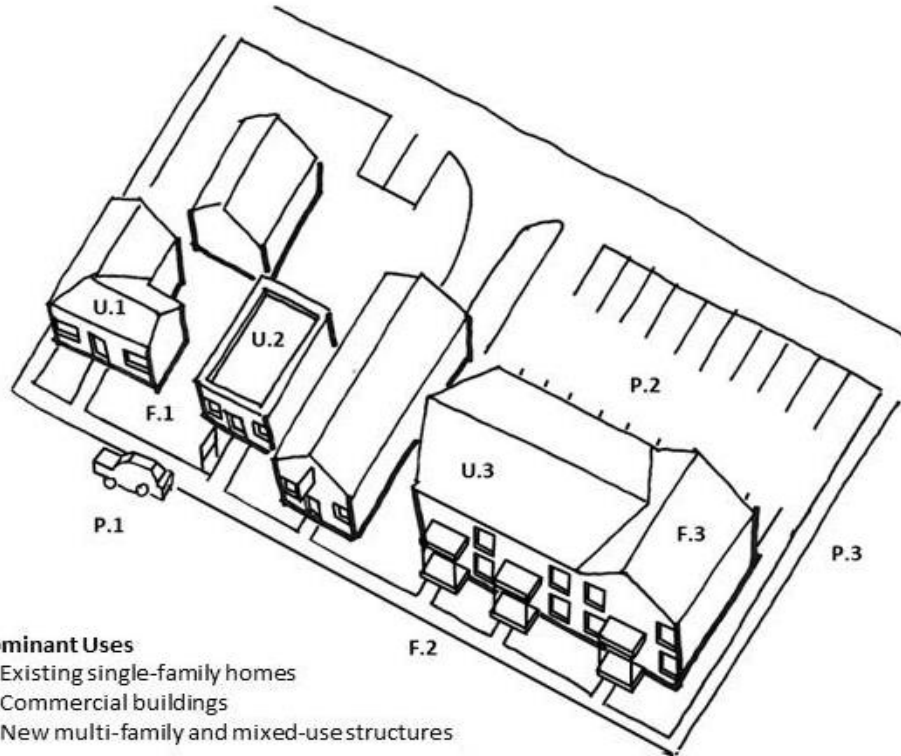

Predominant Uses

- U.1: Existing single-family homes
- U.2: Commercial buildings
- U.3: New multi-family and mixed-use structures

Predominant Form Characteristics

- F.1: New buildings set 5-10' from front property line with parking in back
- F.2: pedestrian-oriented design features (buildings and doors facing the street and building features such as porches, bay windows oriented to the street)
- F.3: New buildings designed to compliment the scale of neighboring structures (through features such as porches and variation in roof lines to break up the building mass)

Parking Arrangements

- P.1: On-street parking
- P.2: Alley-accessed parking behind building
- P.3: Parking on side streets
- P.4: *Not Shown* – Side parking lot or front parking lot (allowed but not encouraged)

B. *Physical Development.* Standards applicable to physical development in the C3 zone are provided on the following pages. Where a cross-reference is listed, see the referenced title, chapter or section for additional standards.

1. <i>Setbacks (min)</i>	<i>Sec. 108.30.040</i>
Front:	5'
Garage/Carport:	20'
Side:	5'
Rear:	10'
2. <i>Impervious Surfaces</i>	
Maximum	90%
3. <i>Building Coverage</i>	
Maximum	n/a
4. <i>Design Standards</i>	<i>Sec. 108.30.140</i>

Buildings	Sec. 108.30.140
Lighting	90° cut-off angle required
Landscaping	
Parking lots	1 tree per 2,000 sf
Street trees	required
Visual screening	between uses
5. Fencing	
Height in any front yard (max)	4'
Height in any side yard (max)	6'
Height in any rear yard (max)	6'
6. Building Height	
Maximum	35'
7. Environmental Standards	
Shoreline Development	Title 109
SEPA Review	Title 110
Critical Area Buffers	Title 112
Wetlands	50'—300'
CARAs	protect water source
Frequently Flooded Areas	50'
Geologically Hazardous Areas	slope ht.
Wildlife Habitat	varies
8. Signs	
<i>Sec. 108.30.130</i>	
9. Grading, Erosion Control, Stormwater (reserved)	
10. Required Physical Development Permits (reserved)	

- C. *Allowed uses and use standards.* Standards applicable to use are provided in this subsection. Where a cross-reference is listed, see the referenced title, chapter, or section for additional standards. All standards in Title 106 and Title 108 are applicable unless stated otherwise.

1. Allowed Uses			2. Parking (Ch. 108.50)	
Use	Definition/ Standards	Permit	Minimum	Maximum
Residential Uses				
Detached Single-Family Unit	[108.40.040.B.]	Y*	2 per DU	n/a
Attached Single-Family Unit	[108.40.040.D.]	A	1.5 per DU	2 per DU
Group Home	[108.40.040.E.]	A	0.5 per bed	1.5 per bed
Lodging Uses				
Conventional Lodging	[108.40.050.B.]	Y	0.6 per LU	2 per LU
Institutional Uses				
Assembly	[108.40.060.B.]	Y	Independent Calculation	
Daycare Center	[108.40.060.C.]	Y	1 per 1,000 sf	1 per 1,000 sf

School	[108.40.060.D.]	C	Independent Calculation	
Emergency Services	[108.40.060.E.]	A	Independent Calculation	
Commercial Uses				
Office	[108.40.070.B.]	Y	1.5 per 1,000 sf	4 per 1,000 sf
Retail	[108.40.070.C.]	Y	3 per 1,000 sf	6 per 1,000 sf
Service	[108.40.070.D.]	Y	2 per 1,000 sf	4 per 1,000 sf
Restaurant/Bar	[108.40.070.E.]	Y	5 per 1,000 sf	20 per 1,000 sf
Mobile Food Vendor	[108.40.070.F.]	A	Independent Calculation	
Heavy Retail/Service	[108.40.070.G.]	Y	2 per 1,000 sf + 1 per 4,000 sf outdoor display area + 1 per employee	2 per 1,000 sf + 1 per 4,000 sf outdoor display area + 1 per employee
Nursery	[108.40.070.I.]	A	2 per 1,000 sf + 3 per repair bay + 1 per wash bay	6 per 1,000 sf + 3 per repair bay + 1 per wash bay
Battery Exchange Station	[108.40.070.J.]	C	Independent Calculation	
Marijuana Business	[108.40.070.K.]	A	3 per 1,000 sf	6 per 1,000 sf
Amusement and Recreation				
Amusement	[108.40.080.B.]	A	3 per 1,000 sf	5 per 1,000 sf
Outdoor Recreation	[108.40.080.C.]	Y	Independent Calculation	
Developed Recreation	[108.40.080.D.]	Y	Independent Calculation	
Industrial Uses				
Craft Food Production	[108.40.090.B.]	A	Independent Calculation	
Light Industry	[108.40.090.C.]	A	0.5 per employee + 1 per company vehicle	1 per employee + 1 per company vehicle

Transportation and Infrastructure Uses				
Parking	[108.40.100.B.]	A	n/a	n/a
Utility Facility	[108.40.100.C.]	C	1 per employee + 1 per stored vehicle	1 per employee + 1 per stored vehicle
Wireless Telecommunications Facility	See Sec. 108.40.100.E.		1 per employee + 1 per stored vehicle	1 per employee + 1 per stored vehicle
Accessory Uses				
Bed and Breakfast	[108.40.110.C.]	Y	0.75 per LU	1.5 per LU
Home Occupation	[108.40.110.D.]	Y	n/a	n/a
Home Business	[108.40.110.E.]	A	1 per employee	1 per employee
Drive-Up Facility	[108.40.110.F.]	A	n/a	n/a
Home Daycare	[108.40.110.G.]	A	1 per employee	1 per employee
Battery Charging Station	[108.40.110.H.]	Y	n/a	n/a
Temporary Uses				
Yard Sale	[108.40.120.B.]	Y	n/a	n/a
Christmas Tree Sales	[108.40.120.C.]	Y	1 per 1,000 sf outdoor display area + 1 per employee	1 per 1,000 sf outdoor display area + 1 per employee
Farm Stand	[108.40.120.D.]	Y	5 per 1,000 sf display area	5 per 1,000 sf display area
Temporary Real Estate Sales Office	[108.40.120.E.]	A	2	4
Temporary Shelter	[108.40.120.F.]	A	2 per DU	2 per DU
Temporary Gravel Processing	[108.40.120.G.]	A	1 per employee	1 per employee
Y = allowed without use permit A = Administrative Use Permit required C = Conditional Use Permit required PF = Public Facilities Use Permit required (PO) = Only allowed in the PO Overlay				

* = Use that was legally established prior to November 13, 2012 is allowed to continue as an allowed conforming use. No new uses are allowed in the zone.

3. Performance Standards	
Outdoor Storage	(Sec. 108.60.020)
Recreational Vehicles	allowed if standards are met
Outdoor Storage Areas and Yards	allowed if standards are met
Shipping Containers and Compartments	allowed if standards are met
Refuse and Recycling	(Sec. 108.60.030)
Trash and recycling enclosure required	>4 DUs and all nonresidential
Noise	(Sec. 108.60.040)
Sound level at property line (max)	75 DBA
Vibration	(Sec. 108.60.050)
Odors	(Sec. 108.60.060)
Light and Glare	(Sec. 108.60.070)
Radioactivity and Electrical Disturbances	(Sec. 108.60.080)

D. Lot standards.

1. Minimum lot size.

- a. Width: 20 feet.
- b. Depth: 55 feet.

2. Maximum residential density. Residential density is calculated by dividing the number of dwelling units by the site area. The allowed density is generally based on the availability of a sewer system. Where sewer is not available, the city defers to the Thurston County Health Department to establish maximum densities.

- a. Individual water and septic: Defers to Thurston County standards.
- b. Public water and individual septic: Defers to Thurston County standards.
- c. Public water and sewer. 40 du/ac.

E. Development options and subdivision. (Reserved).

F. Additional zone-specific standards.

1. Attached single-family dwellings. The side yard setback may be reduced to zero feet when a row of townhouses or other attached dwelling units are constructed on different lots as part of the same development.

2. On-street parking. Required parking may be provided on-street provided the following standards are met.

- a. An on-street parking space shall have the following length of uninterrupted curb adjoining to the lot of record of the proposed use.

Uninterrupted Curb Per On-Street Parking Space	
Parking Space Angle	Uninterrupted Curb
Parallel	22'

45°/60°	20'
90°	9'

- b. On-street parking shall not be provided along a yellow curb or other no parking areas put in place by the City or WSDOT.
- c. The on-street parking shall follow the established configuration of existing on-street parking.
- d. On-street parking spaces shall be available for use by the public at all times. Signs or actions limiting public use of on-street spaces are prohibited.

(Ord. No. 881, § 31, 9-26-2017)

106.40.040. Industrial (I) zone.

- A. *Intent.* The industrial zone provides for some commercial and utilities activities and large-scale industrial types of activities. The designation allows for the manufacturing freight warehousing and finished product movement areas.
- B. *Physical development.* Standards applicable to physical development in the I zone are provided on the following pages. Where a cross-reference is listed, see the referenced title, chapter or section for additional standards.

1. Setbacks (min)	<i>Sec. 108.30.040</i>
Front:	0'
Garage/Carport:	0'
Side:	0'
Rear:	0'
2. Impervious Surfaces	
Maximum	100%
3. Building Coverage	
Maximum	n/a
4. Design Standards	<i>Sec. 108.30.140</i>
Buildings	<i>Sec. 108.30.140</i>
Lighting	90° cut-off angle required
Landscaping	
Parking lots	1 tree per 2,000 sf
Street trees	required
Visual screening	between uses
5. Fencing	<i>Sec 108.30.040</i>
Height in any front yard (max)	4'
Height in any side yard (max)	6'
Height in any rear yard (max)	6'
6. Building Height	<i>Sec. 108.30.040</i>
Maximum	40'
7. Environmental Standards	
Shoreline Development	Title 109
SEPA Review	Title 110
Critical Area Buffers	Title 112

Wetlands	50'—300'
CARAs	protect water source
Frequently Flooded Areas	50'
Geologically Hazardous Areas	slope ht.
Wildlife Habitat	varies
8. Signs	Sec. 108.30.130
9. Grading, Erosion Control, Stormwater (reserved)	
10. Required Physical Development Permits (reserved)	

- C. *Allowed uses and use standards.* Standards applicable to use are provided in this subsection. Where a cross-reference is listed, see the referenced title, chapter, or section for additional standards. All standards in Title 106 and Title 108 are applicable unless stated otherwise.

1. Allowed Uses			2. Parking (Ch. 108.50)	
Use	Definition/Standards	Permit	Minimum	Maximum
<i>Institutional Uses</i>				
Emergency Services	[108.40.060.E.]	A	Independent Calculation	
<i>Commercial Uses</i>				
Mobile Food Vendor	[108.40.070.F.]	A	Independent Calculation	
Heavy Retail/Service	[108.40.070.G.]	C	2 per 1,000 sf + 3 per repair bay + 1 per wash bay	6 per 1,000 sf + 3 per repair bay + 1 per wash bay
Storage	[108.40.070.H.]	A	1 per 10 storage units + 1 per employee	1 per 10 storage units + 1 per employee
Nursery	[108.40.070.I.]	A	2 per 1,000 sf + 1 per 4,000 sf outdoor display area + 1 per employee	2 per 1,000 sf + 1 per 4,000 sf outdoor display area + 1 per employee
Battery Exchange Station	[108.40.070.J.]	A	Independent Calculation	
Marijuana Business	[108.40.070.K.]	A	3 per 1,000 sf	6 per 1,000 sf
Sexually Oriented Business	[108.40.070.L.]	C	3 per 1,000 sf	6 per 1,000 sf

<i>Industrial Uses</i>				
Craft Food Production	[108.40.090.B.]	Y	Independent Calculation	
Light Industry	[108.40.090.C.]	Y	0.5 per employee + 1 per company vehicle	1 per employee + 1 per company vehicle
Heavy Industry	[108.40.090.D.]	C	0.5 per employee + 1 per company vehicle	1 per employee + 1 per company vehicle
Disposal	[108.40.090.E.]	PF	1 per employee	1 per employee
<i>Transportation and Infrastructure Uses</i>				
Parking	[108.40.100.B.]	A	n/a	n/a
Utility Facility	[108.40.100.C.]	C	1 per employee + 1 per stored vehicle	1 per employee + 1 per stored vehicle
Sewer Facility	[108.40.100.D.]	PF	1 per employee + 1 per stored vehicle	1 per employee + 1 per stored vehicle
Wireless Telecommunications Facility	See Sec. 108.40.100.E.		1 per employee + 1 per stored vehicle	1 per employee + 1 per stored vehicle
<i>Accessory Uses</i>				
Battery Charging Station	[108.40.110.H.]	Y	n/a	n/a
<i>Temporary Uses</i>				
Yard Sale	[108.40.120.B.]	Y	n/a	n/a
Christmas Tree Sales	[108.40.120.C.]	Y	1 per 1,000 sf outdoor display area + 1 per employee	1 per 1,000 sf outdoor display area + 1 per employee

Farm Stand	[108.40.120.D.]	Y	5 per 1,000 sf display area	5 per 1,000 sf display area
Temporary Real Estate Sales Office	[108.40.120.E.]	A	2	4
Temporary Shelter	[108.40.120.F.]	A	2 per DU	2 per DU
Temporary Gravel Processing	[108.40.120.G.]	A	1 per employee	1 per employee
Y = allowed without use permit A = Administrative Use Permit required C = Conditional Use Permit required PF = Public Facilities Use Permit required (PO) = Only allowed in the PO Overlay				

<i>3. Performance Standards</i>	
Outdoor Storage	(Sec. 108.60.020.)
Recreational Vehicles	allowed if standards are met
Outdoor Storage Areas and Yards	allowed if standards are met
Shipping Containers and Compartments	allowed if standards are met
Refuse and Recycling	(Sec. 108.60.030)
Trash and recycling enclosure required	>4 DUs and all nonresidential
Noise	(Sec. 108.60.040)
Sound level at property line (max)	75 DBA
Vibration	(Sec. 108.60.050)
Odors	(Sec. 108.60.060)
Light and Glare	(Sec. 108.60.070)
Radioactivity and Electrical Disturbances	(Sec. 108.60.080)

- D. *Lot standards.* (Reserved).
 - E. *Development options and subdivision.* (Reserved).
 - F. *Additional zone-specific standards.* (Reserved).
- (Ord. No. 881, § 31, 9-26-2017)

CHAPTER 106.50. SPECIAL PURPOSE ZONES

106.50.010. Public/semi-public (P/SP) zone.

- A. *Intent.* The public/semi-public zone provides for moderate- and large-scale activities relating to the purposes of state and local governmental entities and semi-public institutions by providing necessary public services. The designation allows for the specialized needs of providing public services to all areas of Tenino.
- B. *Physical development.* Standards applicable to physical development in the P/SP zone are provided on the following pages. Where a cross-reference is listed, see the referenced title, chapter or section for additional standards.

1. Setbacks (min)		<i>Sec. 108.30.040</i>
Front:		0'
Garage/Carport:		0'
Side:		0'
Rear:		0'
2. Impervious Surfaces		
Maximum		100%
3. Building Coverage		
Maximum		n/a
4. Design Standards		<i>Sec. 108.30.140</i>
Buildings		n/a
Lighting		n/a
Landscaping		
Parking lots		n/a
Street trees		n/a
Visual screening		n/a
5. Fencing		<i>Sec 108.30.040</i>
Height in any front yard (max)		4'
Height in any side yard (max)		6'
Height in any rear yard (max)		6'
6. Building Height		<i>Sec. 108.30.040</i>
Maximum		case by case
7. Environmental Standards		
Shoreline Development		Title 109
SEPA Review		Title 110
Critical Area Buffers		Title 112
Wetlands		50'—300'
CARAs		protect water source
Frequently Flooded Areas		50'
Geologically Hazardous Areas		slope ht.
Wildlife Habitat		varies
8. Signs		<i>Sec. 108.30.130</i>
9. Grading, Erosion Control, Stormwater (reserved)		
10. Required Physical Development Permits (reserved)		

C. *Allowed uses and use standards.* Standards applicable to use are provided in this subsection. Where a cross-reference is listed, see the referenced title, chapter, or section for additional standards. All standards in Title 106 and Title 108 are applicable unless stated otherwise.

1. Allowed Uses			2. Parking (Ch. 108.50)	
<i>Use</i>	<i>Definition/Standards</i>	<i>Permit</i>	<i>Minimum</i>	<i>Maximum</i>
Lodging Uses				
Campground	[108.40.050.C.]	A	1 per campsite + 1	n/a

			per 7.5 campsites	
<i>Institutional Uses</i>				
Assembly	[108.40.060.B.]	Y	Independent Calculation	
Daycare Center	[108.40.060.C.]	Y	0.5 per employee	1 per employee
School	[108.40.060.D.]	C	Independent Calculation	
Emergency Services	[108.40.060.E.]	A	Independent Calculation	
<i>Commercial Uses</i>				
Office	[108.40.070.B.]	Y	1 per 1,000 sf	5.5 per 1,000 sf
Mobile Food Vendor	[108.40.070.F.]	A		
<i>Amusement and Recreation</i>				
Amusement	[108.40.080.B.]	A	3 per 1,000 sf	5 per 1,000 sf
Outdoor Recreation	[108.40.080.C.]	Y	Independent Calculation	
Developed Recreation	[108.40.080.D.]	Y	Independent Calculation	
<i>Transportation and Infrastructure Uses</i>				
Parking	[108.40.100.B.]	A	n/a	n/a
Utility Facility	[108.40.100.C.]	C	1 per employee + 1 per stored vehicle	1 per employee + 1 per stored vehicle
Sewer Facility	[108.40.100.D.]	PF	1 per employee + 1 per stored vehicle	1 per employee + 1 per stored vehicle
Wireless Telecommunications Facility	See Sec. 108.40.100.E.		1 per employee + 1 per stored vehicle	1 per employee + 1 per stored vehicle
<i>Accessory Uses</i>				
Battery Charging Station	[108.40.110.H.]	Y	n/a	n/a

<i>Temporary Uses</i>				
Yard Sale	[108.40.120.B.]	Y	n/a	n/a
Farm Stand	[108.40.120.D.]	Y	5 per 1,000 sf display area	
Temporary Real Estate Sales Office	[108.40.120.E.]	A	2	4
Temporary Shelter	[108.40.120.F.]	A	2 per DU	2 per DU
Temporary Gravel Processing	[108.40.120.H.]	A	1 per employee	
Y = allowed without use permit A = Administrative Use Permit required C = Conditional Use Permit required PF = Public Facilities Use Permit required (PO) = Only allowed in the PO Overlay				

<i>3. Performance Standards</i>	
Outdoor Storage	(Sec. 108.60.020)
Recreational Vehicles	allowed if standards are met
Outdoor Storage Areas and Yards	allowed if standards are met
Shipping Containers and Compartments	allowed if standards are met
Refuse and Recycling	(Sec. 108.60.030)
Trash and recycling enclosure required	>4 DUs and all nonresidential
Noise	(Sec. 108.60.040)
Sound level at property line (max)	75 DBA
Vibration	(Sec. 108.60.050)
Odors	(Sec. 108.60.060)
Light and Glare	(Sec. 108.60.070)
Radioactivity and Electrical Disturbances	(Sec. 108.60.080)

- D. *Lot standards.* (Reserved).
 - E. *Development options and subdivision.* (Reserved).
 - F. *Additional zone-specific standards.* (Reserved).
- (Ord. No. 881, § 32, 9-26-2017)

106.50.020. West Tenino (WT) zone.

- A. *Intent.* The purpose of the West Tenino zone is to:
 1. Require the adoption of a master plan prior to any subdivision of land, except those subdivisions of land that occur subject to RCW 58.17.040(1), or RCW 58.17.040(3) through 58.17.040(9), to ensure that a number of smaller land divisions do not make the site unusable for future urban development.

2. Provide requirements and guidelines for the development of the area, including items such as the layout of road connections and certain building forms and uses to facilitate the development of an individual or series of master plans for the site.
 3. Specify the land uses that are allowed in the area prior to the creation of a master plan or any subdivision of property.
- B. *Physical development.* Standards applicable to physical development in the WT zone are provided on the following pages. Where a cross-reference is listed, see the referenced title, chapter or section for additional standards.

1. Setbacks (min)		<i>Sec. 108.30.040</i>
Use Type	Setback based on Street Type	
	Arterial and State Highway	Collector, Local, and Private
<i>Nonresidential Uses</i>		
Front:	35'	25'
Side Street:	10'	10'
Side:	10'	10'
Rear:	10'	10'
<i>Attached Single-Family Uses (3 or more units)</i>		
Front:	30'	20'
Side Street:	10'	10'
Side:	10'	10'
Rear:	10'	10'
<i>Detached Single-Family and Duplex Uses</i>		
Front:	30'	20'
Side Street:	10'	10'
Side:	6'	6'
Rear:	6'	6'
<i>Buildings Housing Animals</i>		
Front:	50'	50'
Side Street:	10'	10'
Side:	35'	35'
Rear:	35'	35'

2. <i>Impervious Surfaces (max)</i>	
Hydrologic soil groups C and D	
Lots less than 5 acres	45%
Lots 5 acres or more	10%
Hydrologic soil groups A and B	
	60%
3. <i>Building Coverage (max)</i>	
Lots 10 acres or less	6,000 sf
Lots more than 10 acres	20,000 sf
4. <i>Design Standards</i>	
Buildings	n/a
Lighting	n/a

Landscaping	
Parking lots	n/a
Street trees	n/a
Visual screening	n/a
5. Fencing	
Height in any front yard (max)	4'
Height in any side yard (max)	6'
Height in any rear yard (max)	6'
6. Building Height	
Maximum	35'
7. Environmental Standards	
Shoreline Development	Title 109
SEPA Review	Title 110
Critical Area Buffers	Title 112
Wetlands	50'—300'
CARAs	protect water source
Frequently Flooded Areas	50'
Geologically Hazardous Areas	slope ht.
Wildlife Habitat	varies
8. Signs	
9. Grading, Erosion Control, Stormwater (reserved)	
10. Required Physical Development Permits (reserved)	

- C. *Allowed uses and use standards.* Standards applicable to use are provided in this subsection. Where a cross-reference is listed, see the referenced title, chapter, or section for additional standards. All standards in Title 106 and Title 108 are applicable unless stated otherwise.

1. Allowed Uses			2. Parking (Ch. 108.50)	
Use	Definition/Standards	Permit	Minimum	Maximum
Open Space Uses				
Agriculture	[108.40.030.B.]	Y	n/a	n/a
Residential Uses				
Detached Single-Family Unit	[108.40.040.B.]	Y	2 per DU	n/a
Institutional Uses				
Assembly	[108.40.060.B.]	C	Independent Calculation	
Commercial Uses				
Retail	[108.40.070.C.] [106.40.020.F.2.]	Y	3 per 1,000 sf	6 per 1,000 sf
Restaurant/Bar	[108.40.070.E.] [106.40.020.F.2.]	Y	5 per 1,000 sf	20 per 1,000 sf
Heavy Retail/Service	[108.40.070.G.] [106.40.020.F.3.]	Y	2 per 1,000 sf + 3 per repair	6 per 1,000 sf + 3 per repair

			bay + 1 per wash bay	bay + 1 per wash bay
<i>Amusement and Recreation</i>				
Outdoor Recreation	[108.40.080.C.]	C	Independent Calculation	
Developed Recreation	[108.40.080.D.]	C	Independent Calculation	
<i>Transportation and Infrastructure Uses</i>				
Utility Facility	[108.40.100.C.]	C	1 per employee + 1 per stored vehicle	1 per employee + 1 per stored vehicle
<i>Accessory Uses</i>				
Accessory Dwelling Unit	[108.40.110.B.] [106.40.020.F.1.]	A	1 per DU	2 per DU
Bed and Breakfast	[108.40.110.C.]	Y	0.75 per LU	1.5 per LU
Home Occupation	[108.40.110.D.]	A	n/a	n/a
Home Business	[108.40.110.E.]	C	1 per employee	1 per employee
Home Daycare	[108.40.110.G.]	A	1 per employee	1 per employee
Battery Charging Station	[108.40.110.H.]	Y	n/a	n/a
<i>Temporary Uses</i>				
Farm Stand	[108.40.120.D.]	Y	5 per 1,000 sf display area	5 per 1,000 sf display area
<p>Y = allowed without use permit A = Administrative Use Permit required C = Conditional Use Permit required PF = Public Facilities Use Permit required (PO) = Only allowed in the PO Overlay</p>				

<i>3. Performance Standards</i>	
Outdoor Storage	(Sec. 108.60.020)
Recreational Vehicles	allowed if standards are met
Outdoor Storage Areas and Yards	allowed if standards are met
Shipping Containers and Compartments	allowed if standards are met
Refuse and Recycling	(Sec. 108.60.030.)
Trash and recycling enclosure required	>4 DUs and all nonresidential
Noise	(Sec. 108.60.040)
Sound level at property line (max)	75 DBA

Vibration	(Sec. 108.60.050)
Odors	(Sec. 108.60.060)
Light and Glare	(Sec. 108.60.070)
Radioactivity and Electrical Disturbances	(Sec. 108.60.080)

D. *Lot standards.* (Reserved).

E. *Development options and subdivision.*

1. *Subdivision prohibited.* Subdivision is prohibited prior to establishing a Master Plan except for those divisions that occur subject to RCW 58.17.040(1) or RCW 58.17.040(3) through 58.17.040(9):
 - a. Cemeteries and other burial plots.
 - b. Divisions made by testamentary provisions, or the laws of descent.
 - c. Divisions in accordance with an approved binding site plan.
 - d. Divisions for the purpose of lease in association with an approved binding site plan.
 - e. Boundary line adjustments.
 - f. Divisions for the purpose of leasing land for wireless telecommunications facilities.
 - g. Divisions of land into lots or tracts less than three acres in size for the purpose of establishing a utility facility.

F. *Additional zone-specific standards.*

1. *Accessory dwelling units.*
 - a. *Additional ADUs.* All lots with an existing single-family dwelling that is also actively farmed may be allowed one ADU. For lots that exceed 20 acres in size, one additional ADU is allowed for every 20 additional acres.

Example: An agriculture operation is sited on a 79-acre parcel of land. One ADU is allowed outright. One ADU is allowed for every 20 additional acres for a total of 3 ADUs (1 + (79-20)/20 = 3.95).
 - b. The ADUs must be clustered together and in proximity to a principal residential dwelling.
 - c. Accessory dwelling units must not be subdivided separate from the agricultural operation.
 - d. The sewage disposal and water supply must be approved by the City of Tenino.
2. *Retail and restaurants/bars.* Retail and restaurant/bar uses must be in a farmer's market format.
3. *Heavy retail/service.* Heavy retail/service uses shall be limited to no more than 5,000 square feet of floor area.
4. *West Tenino Master Plans.* A master plan pursuant to Section 100.55, Master Planned Developments, is required for any subdivision of land except for those subdivisions that occur subject to subsection E.1. above.
 - a. *Required master plan elements.* The master plan must include the following elements and must describe the fundamental characteristics of the proposed development as well as future development of neighboring properties.
 - i. *Transportation element.*

-
- ii. *Utilities element.* The utilities element must include a plan for ensuring there are water rights sufficient to accommodate the anticipated uses on the site.
 - iii. *Land use element.* The land use element must include a description of all proposed uses. Residential development must have an average net density of at least 6 dwelling units per acre.
 - iv. *Design guidelines element.* The design guidelines must include information on how sandstone will be used in the area.
- b. *Reserve areas allowed.* Reserve areas for future master plans may be established in the West Tenino Residential area (shown below) as part of a master plan. Reserve areas must be at least 20 acres in size, and have a shape appropriate for the development of a future master plan. When a reserve area is utilized, the transportation element and utilities element of the original master plan must show how roadways and utilities will be provided to the reserve area.
 - c. *Master plan principles.* A master plan should be designed in accordance with the following guidelines for the site.
 - i. *Form and use principles.* The following principles are meant to articulate the desired placement of building forms and land uses throughout various districts of the master plan area. The general location that these different forms and uses apply is shown below. Variations on the location of these districts are appropriate, so long as the districts meet the fundamental intent for each area as articulated below.

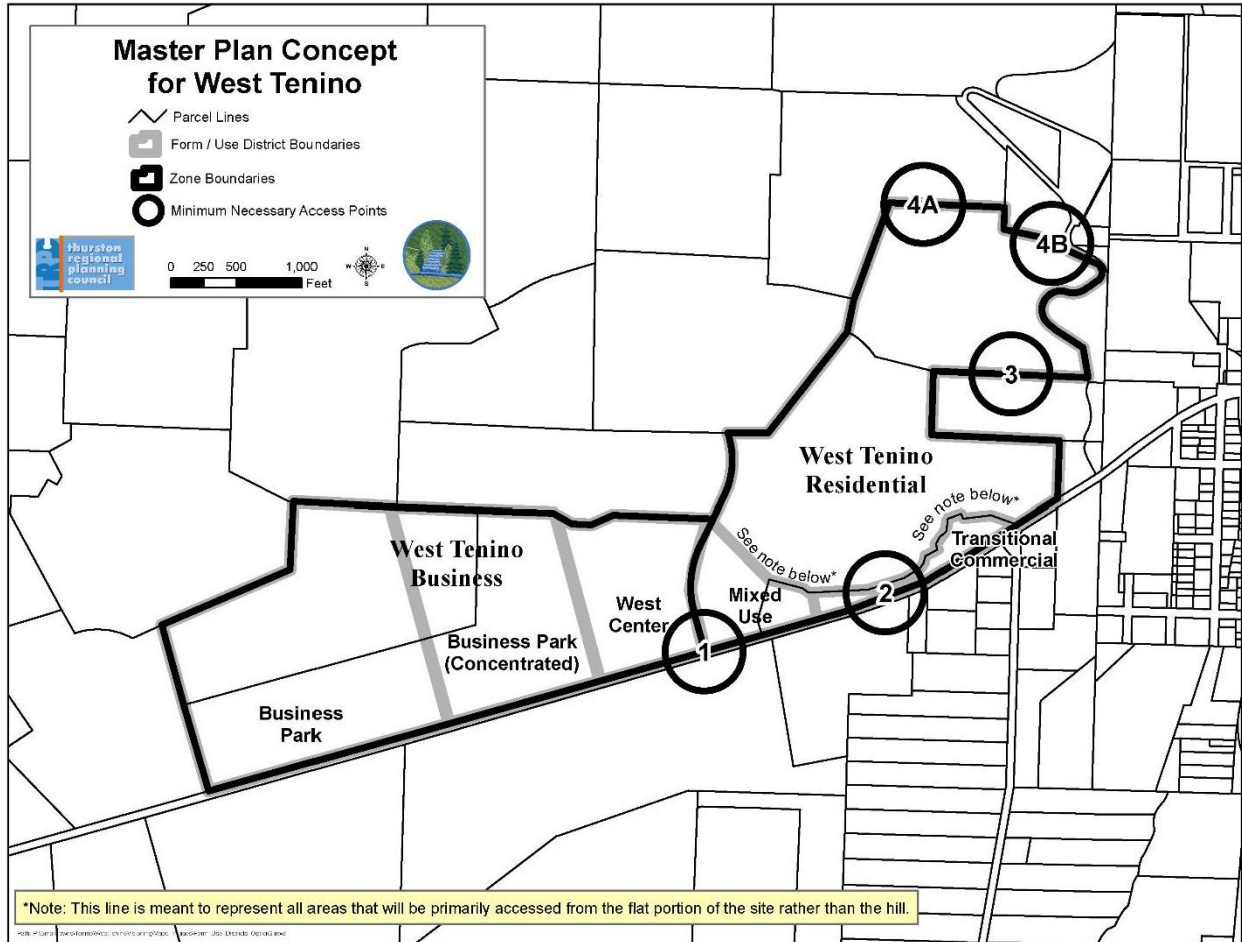

(a) *Business park area.*

- (1) *Form.* Buildings in the business park area may become even more spread out than in the concentrated business park. Buildings should be visually obscured from Old Highway 99 by the existing topography.
- (2) *Access.* Buildings should generally be accessed via a secondary access road (or roads) off of Old Highway 99.
- (3) *Setbacks.* Buildings are encouraged to be set at or near the front property line along the secondary access roads.
- (4) *Uses.* Appropriate uses for the business park area include agriculture, light industry, service, office, and heavy retail/service. Residential uses may also be appropriate, particularly in the northern portion of the area, but must not exceed 35 percent of the area. Residential uses should be consistent with the form principles for the West Tenino Residential area (subsection F.3.d.i.(e). below) rather than the business park area.

(b) *Business park (concentrated) area.*

- (1) *Form.* Transitioning away from the West Center area, buildings may become less dense with yards, landscaping or parking located between the structures, though the structures should continue. Blocks may be

longer than seen in the West Center area, but should not exceed 800 feet in length.

- (2) *Setbacks.* Buildings should be set at or near the front property line.
- (3) *Uses.* Appropriate uses for the business park (concentrated) area include light industry, office, and heavy retail/service. Residential uses may also be appropriate, particularly in the northern portion of the area, but must not exceed 35 percent of the area. Residential uses should be consistent with the form principles for the West Tenino Residential area (subsection F.3.d.i.(e). below) rather than the business park (concentrated) area.

(c) *West Center Area.*

- (1) *Form.* The West Center Area of the site should provide a small retail and cultural center that is located close to the residential area on the hill and the business areas on the flat portion of the site. The area should contain a pedestrian-oriented configuration of buildings that frames the street front. Sandstone features should also be present on some of the buildings to acknowledge the city's history. Parking should be located behind the structures and be served by an alley to maintain this pedestrian-oriented street front, though on-street parking is also appropriate and encouraged. Blocks should range in length from 240 to 400 feet.
- (2) *Setbacks.* Buildings should be set at or near the front property line and should have no side yards.
- (3) *Uses.* Appropriate uses for the West Center Area include retail, service, offices, and residential. Residential uses must not exceed 35 percent of the area. The pond on the north portion of this area should be considered an amenity and be designed as a park with a trail around the pond, or some other park-like use.

(d) *Transitional commercial area.*

- (1) *Form.* The western portion of the transitional commercial area should be a continuation of the retail and cultural center functions of the West Center area. Form should generally follow the characteristics listed for the West Center area. The eastern portion of the transitional commercial area (beyond where the hill creates a narrow strip of land between the hillside and roadway) may have buildings that are spread farther apart with parking located between the structures.
- (2) *Uses.* Appropriate uses for the transitional commercial area include retail, service, light industrial, and office. Residential uses are prohibited unless it can be demonstrated that there is no potential for nuisance odors from the Tenino Wastewater Treatment Plant that could have a negative impact on dwellings at any point in the future.

(e) *West Tenino residential area.*

- (1) *Form.* A mix of housing types is appropriate. Mixed-use development may also be appropriate but may not in total exceed the ten percent of the area. Mixed use buildings should have some sandstone features and be pedestrian oriented with parking at the rear of buildings.

-
- (2) *Access.* Dwellings should generally be accessed by a well-connected street system with few cul-de-sacs. A pedestrian system with paths and/or sidewalks throughout the area should also be incorporated.
 - (3) *Uses.* Appropriate uses for the Residential area include detached single-family dwellings, attached single-family dwellings, and retail when located in a mixed-use building. Open space associated with critical areas, such as the wetlands in the ravines on the hill, could include a trail system, and a park or trail system could provide views from areas on the hill.

ii. *Connectivity principles.*

(a) *Street connections.*

- (1) *Lemon Hill Roadway Network and Access Points.* The figure above shows the general location of necessary access points and the basic road connections that should be made on the hill portion of the West Tenino zone. Roadway locations and access points are meant to depict the primary arterial/collector corridors and minimum connectivity requirements necessary for the site. The figure is not meant to depict all roadways that will be constructed in the area. The placement of each roadway and access point may be moved to best suit the site design. However, the number of connections and access points should not decrease. The basic road connections required include:
 - (A) *Morningside Drive connector.* A connection from the flat portion of the site to Morningside Drive (the line connecting 1 to 4A or 4B). The Morningside Drive connector, should be considered as part of the Main Roadway Spine.
 - (B) *Old Highway 99 connector.* A connection from Old Highway 99 to the Morningside Drive Connector (the line connecting 2 and the line between 1 and 4A or 4B).
 - (C) *City connector.* A connection from the Main Roadway Spine to an adjacent parcel within City limits that is over ten acres in size as of December 13, 2011 (the line connecting 3 and the line between 1 and 4A or 4B).
 - (D) *County connector.* A connection from the Main Roadway Spine to an adjacent parcel more than ten acres in size as of December 13, 2011 that is located outside city limits. The parcel must also be located on Lemon Hill. This connection may be created through a roadway, a dedicated easement or a dedication for a future potential roadway to the adjacent parcel. The connection is intended to ensure connectivity should the land in unincorporated county be developed in the future.
- (2) *Westside Prairie Roadway Network and Access Points.* No access points or roadway network are depicted in the figure above for the flat portion of the site. Within the area, the roadway network may be tailored to best suit the design of the master plan, but should generally include the following characteristics:

-
- (A) A street system that is consistent with the district form principles articulated in subsection F.3.c.i. above;
 - (B) A well-connected roadway network (with few if any cul-de-sacs); and
 - (C) An extension of the Main Roadway Spine that connects the Spine to Lemon Hill (discussed below).
- (3) *Main Roadway Spine.* The main spine through the site should connect the western part of the flat portion of the site (and Old Highway 99) to Morningside Drive. The Main Roadway Spine should be designed in a manner consistent throughout its entire length. The design should define West Tenino as a unique area and include sidewalks on both sides of the street, planter strips, and bike lanes. A median in the center of the roadway should also be considered to help distinguish the road from others in the community and contribute to the sense that West Tenino is a distinct area of the community.
- (b) *Trail connections.* A trail should be constructed on the site that will eventually link to the Yelm/Tenino Trail. This trail should generally skirt along the bottom edge of Lemon Hill and be connected to trails, sidewalks and/or bike lanes that descend the hill. West of Lemon Hill, the trail may: Continue as an individual, stand-alone trail that travels through the West Center and Business Park areas; tie into bike lanes and sidewalks on the main roadway spine; or travel an alternative route that is based on the placement of parks within the master plan. Bike and pedestrian facilities should be considered a fundamental amenity necessary to connect West Tenino to downtown Tenino.

(Ord. No. 881, § 32, 9-26-2017)