

APPLICATION FOR ECONOMIC DEVELOPMENT INCENTIVE

The following information is required for all projects requesting economic development incentives from the Sweeny Economic Development Corporation ("SEDC"). Incomplete applications will not be considered. If any requested information is not applicable, please enter "N/A" in the space. After receipt of the application, the SEDC may require additional information to be submitted.

Business Name:
Sweeny Tire & Auto
Mailing Address:
1002 n. Main St., Sweeny, TX 77480
Phone Number:
979-548-6341
Website:
Sweenytire@windstream.net
Business Representative:
Paul R. Williams
Mailing Address (if different from above):
Phone Number (if different from above):
Email Address:
Sweenytire@windstream.net

I certify that the information submitted in this application, including attachments, is true, correct, and complete. Omissions or submissions of incorrect information will render this application invalid.



Signature of Business Representative

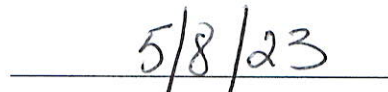

Date

SWEENEY ECONOMIC DEVELOPMENT CORPORATION

Are you applying for incentives for a new or existing business? Please circle one below.

NEW

EXISTING

22,000

The amount of Incentive you are requesting \$ ~~26,500.00~~ .

Please provide the following information about the existing or anticipated location of your business:

Property Address:	
1002 N. Main St.	
Est. Value of Taxable Improvements:	
Building	
Equipment	2 Automotive lifts + added electrical (upgrade)
Utilities Usage Information (Average Actual or Estimated):	
Water	\$80
Gas	None

Please provide the following information about your existing or anticipated employees:

Number of Employees	
Initial	3
After 6 months	3
After 1 year	4
After 2 years	4
After 3 years	4
After 4 years	4
After 5 years	4

Please attach the following:

- Description of how you intend to use the incentive funds for which you are applying
- Business plan
- [If existing business] Report of current finances
- [If existing business] Prior three years of tax returns



6880 E. Loop 1604 S
Adkins, TX 78101
Ph (210) 685-8484

QUOTE

Sweeny Tire & Auto
1002 N. Main St.
Sweeny, TX 77480
(979)548-6341

January 10, 2023

2	TP11KC-DX Two Post Lift 11,000lb Bi-symmetric Arm Design Each \$4,856.56	\$9,713.12
		Freight \$789.96
		Tax \$866.50
		Total \$11,369.58

Quote is valid for 10 days, and NO air, electrical or installation included.

Lift Available for delivery approximately 2 weeks after an order is placed.

Once an order is placed if canceled a 20% restocking fee will be charged

Thank you,

Clark Easley

(361) 765-6448 *

clarkeasley@yahoo.com

11,000 lbs.
Two Post
Direct Drive
Clear Floor
Bi-Symmetric™ Lift

Engineered and built to offer great features at an economical price, the TP11KC-DX features and designs will make this the most used lift in your garage. With versatile user-friendly *Bi-Symmetric™* configurable arms, 3 Stage Front Arms, Symmetric Columns, Single Point Lock Release, Low Profile Arms, Rubber Door Guards and Spin Up Pads with 2" and 4" Stackable Truck Adapters offers everything you'd expect and more!

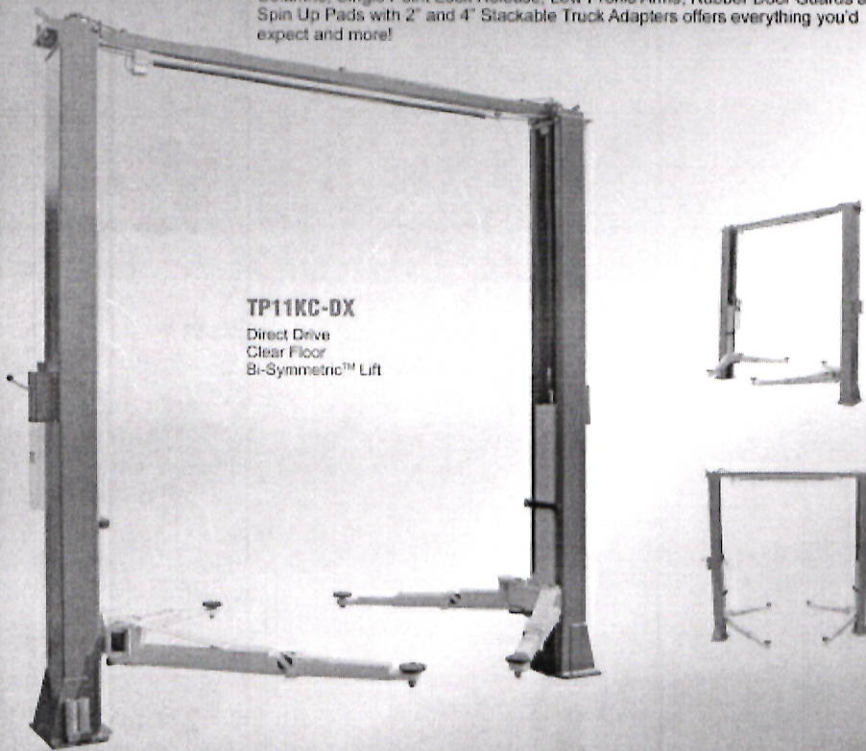

TP11KC-DX
Direct Drive
Clear Floor
Bi-Symmetric™ Lift

Specifications

• Capacity	11,000 lbs.
• Height Overall	144"
• Width Overall w/Power Unit	145-1/2"
• Max. Lift Height	71"
• Min. Pad Height	4"
• Width Between Columns	116"
• Drive Thru Clearance	104"
• Lifting Speed	50S
• Power	220V-20Amp-1PH
• Ship Weight	1,705lbs

Features

- 11,000 lb. lifting capacity
- Direct Drive
- 3 Stage Front Arms
- Asymmetric/ Symmetric Arm Configuration
- Symmetric Columns
- Single Point Lock Release
- Low Profile Arms
- Rubber Door Guards
- Spin Up Pads with Stackable Truck Adapters included 2" and 4"

Bi-Symmetric™ Asymmetric or Symmetric Configuration

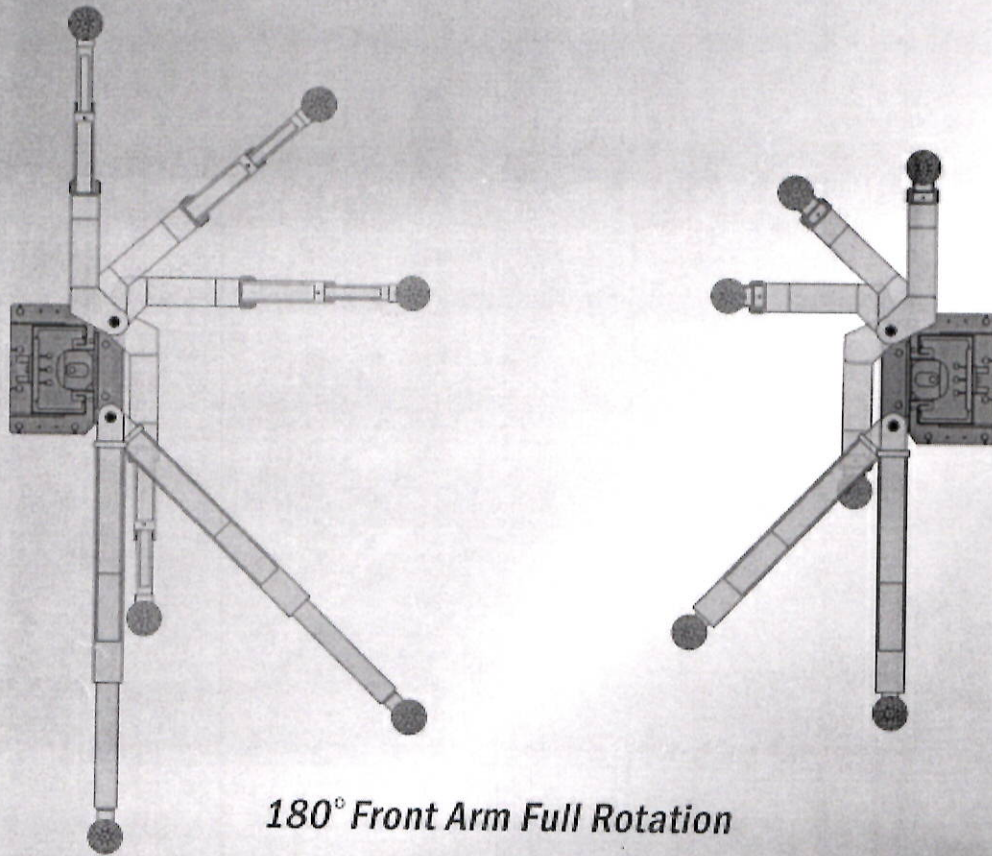

180° Front Arm Full Rotation

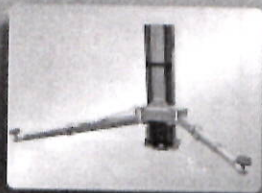

3 Stage Front Arms and
2 Stage Rear Arms

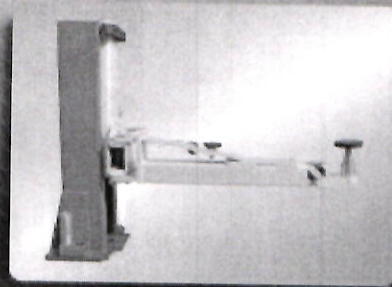

Rubber Door Guards and Spin Up
Pads with Stackable Adapters

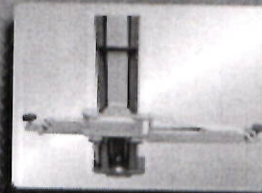

180° Front
Arm Rotation

FL

Family Living Homes, LLC

Barndominiums & Steel Buildings

8678 CR 628

Brazoria, Texas 77422

979-482-0765

Invoice No.

30323

Sheets: 1 of 1

Invoice Submitted To:

Work to be Performed at:

Sweeny Tire & auto

fm 524

Sweeny Tx fm 524 77480

Sweeny Tx 77480

Remove Two car lift's

Install Two new car lift's

Run electrical to both lift's

labor & tool rental

7904.40

1st Draw

3952.20

Completed

3952.20

All material is guaranteed to be as specified, and the above work to performed in accordance with the drawings and specifications submitted for above work and completed in a substantial workmanlike manner for the sum of:

1/2 down when old lift's are removed Balance upon completion

with payments to be as follows: determined by homeowner and contractor

Respectfully submitted

John W. Taylor

Note: This proposal may be withdrawn by us if not accepted within 60 days

ACCEPTANCE OF PROPOSAL

The above prices, specifications and conditions are satisfactory and are hereby accepted. You are authorized to do the work as specified. Payments will be made as outlined above.

5-4-2023

Date

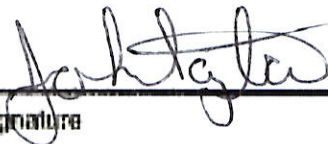
Signature

Signature