

IMPROVEMENT STANDARDS

May 2018

TABLE OF CONTENTS

1.00 PURPOSE.....	1
1.01 GENERAL	1
1.02 EXCEPTIONS	1
2.00 DEFINITIONS.....	2
2.01 GENERAL	2
3.00 GENERAL REQUIREMENTS.....	4
3.01 PLANS AND SPECIFICATIONS REQUIRED	4
3.02 PHASED IMPROVEMENTS	4
3.03 STANDARD SPECIFICATIONS.....	4
3.04 PLAN SUBMITTAL.....	4
3.05 CHANGE IN PLANS DURING CONSTRUCTION	5
3.06 CONTRACTOR AND DEVELOPER RESPONSIBILITY.....	5
3.07 MAINTENANCE GUARANTEE	5
4.00 CONSTRUCTION STAKING	7
4.01 SCOPE.....	7
4.02 CONTROL STAKES	7
4.03 REQUIRED STAKING	7
4.04 CONSTRUCTION STAKE CHECKING.....	9
4.05 CONSTRUCTION STAKING.....	9
4.06 LINES AND GRADES.....	9
4.07 UTILITIES	9
5.00 PLAN DETAILS.....	10
5.01 GENERAL	10
5.02 PLAN CONTENT REQUIREMENTS	10
5.03 PLAN FORMAT REQUIREMENTS.....	12
5.04 ADDITIONAL IMPROVEMENTS TO BE SHOWN	12
5.05 SIGN AND STRIPING PLAN	13
5.06 COMPLIANCE.....	13
6.00 INSPECTION DURING CONSTRUCTION.....	14
6.01 GENERAL	14
6.02 NOTIFICATION.....	14
6.03 COMPLIANCE AND RESPONSIBILITY	14
6.04 INSPECTION FEES	14
6.05 INSPECTION DEPOSIT.....	14
7.00 FINAL INSPECTION	15
7.01 CLEAN UP	15
7.02 CITY ENGINEER INSPECTION	15
8.00 "AS-BUILT" PLAN	15
8.01 "AS-BUILT" PLAN REQUIREMENTS	15
9.00 IMPROVEMENT AGREEMENTS AND SECURITY.....	16
9.01 IMPROVEMENT AGREEMENT	16
9.02 IMPROVEMENT AGREEMENT SECURITY.....	16
9.03 TERMINATION	16
9.04 DEPOSITS AND CERTIFICATES	16
9.05 LETTER OF CREDIT	17

9.06	PERFORMANCE AND LABOR/MATERIALS BOND	17
9.07	SECURITY RELEASE	17
9.08	TIME EXTENSION	17
10.00	DESIGN STANDARDS - STREETS	18
10.01	GENERAL	18
10.02	STREET CLASSIFICATIONS	18
10.03	GRADES, CROSS SLOPE, AND INTERSECTIONS	18
10.04	DESIGN SPEED	19
10.05	GEOMETRIC AND STRUCTURAL SECTIONS	19
10.06	TESTING OF MATERIALS	21
10.07	RIGHT OF WAY	21
10.08	SIGNING AND BARRICADES	21
11.00	DESIGN STANDARDS - STORM DRAINAGE	23
11.01	GENERAL	23
11.02	CLASSIFICATION OF STORM DRAINS	23
11.03	ALIGNMENT	24
11.04	LINES	24
11.05	EASEMENTS	24
11.06	NATURAL DRAINAGE COURSES	24
11.07	DRAINAGE STUDY	25
11.08	DRAINAGE MAP	25
11.09	CALCULATIONS	25
11.10	CLOSED STORM DRAIN SYSTEMS	26
11.11	OPEN CHANNELS	27
11.12	DRAINAGE STRUCTURES	27
12.00	DESIGN STANDARDS – SEWER SYSTEMS	30
12.01	INTRODUCTION	30
12.02	REGULATORY STANDARDS	30
12.03	DESIGN PROCEDURE	30
12.04	BENEFITING AREAS INCLUDED WITHIN PROJECT BOUNDARIES	32
12.05	CALCULATIONS	32
12.06	AVERAGE FLOW DETERMINATION	32
12.07	DESIGN FLOW (PEAK FLOW, OR PF)	33
12.08	PUMPING STATION DESIGN	33
12.09	COLLECTION SYSTEM	34
12.10	TRENCH LOADING	35
12.11	SEWER STRUCTURES	35
12.12	SEWER SERVICES	36
12.13	CREEK CROSSINGS	37
12.14	FORCE MAINS	38
12.15	REGULATIONS RELATING TO SANITARY HAZARDS	38
12.16	LOCATOR WIRE	38
13.00	CONSTRUCTION STANDARDS - STREETS	39
13.01	LINES AND GRADES	39
13.02	ORDER OF WORK	39
13.03	MAINTAINING TRAFFIC	39
13.04	CONSTRUCTION AREA SIGNS	40
13.05	TRAFFIC CONTROL SYSTEM FOR LANE CLOSURE	40
13.06	OBSTRUCTIONS	40
13.07	ADJUST UTILITIES TO GRADE	41
13.08	CLEARING AND GRUBBING	41
13.09	ASPHALT CONCRETE	41

13.10	PAVEMENT REINFORCING FABRIC	41
13.11	FOG SEAL COAT	41
13.12	STRIPING AND PAVEMENT MARKINGS.....	41
13.13	SUBSURFACE DRAIN.....	41
13.14	LOCATE AND PROTECT EXISTING UTILITIES.....	42
14.00	CONSTRUCTION STANDARDS - STREET LIGHTING	43
	GENERAL.....	43
14.01	MATERIALS AND CONSTRUCTION	43
14.02	FOUNDATIONS.....	43
14.03	ELECTROLIER STANDARDS.....	44
14.04	ELECTROLIER ARM.....	44
14.05	CONDUIT	44
14.06	PULL BOXES.....	45
14.07	CONDUCTORS AND WIRING.....	45
14.08	LUMINAIRES.....	45
14.09	LAMPS.....	46
14.10	PHOTOELECTRIC CONTROL.....	46
14.11	SERVICE CONNECTION (NON-SOLAR POWERED LIGHTS)	46
15.00	CONSTRUCTION STANDARDS - STORM DRAIN.....	47
15.01	STORM DRAIN PIPE	47
15.02	INSTALLATION.....	47
15.03	TRENCHES AND BACKFILL	47
15.04	COMPACTION TESTING.....	51
15.05	MANHOLES.....	51
15.06	CONCRETE STRUCTURES	52
15.07	MISCELLANEOUS IRON AND STEEL	52
15.10	ADJUSTING UTILITIES TO GRADE	52
16.00	CONSTRUCTION STANDARDS – SANITARY SEWER	53
	SECTION 01080 - STANDARD SPECIFICATIONS.....	54
	SECTION 01210 - PRECONSTRUCTION CONFERENCE	55
	SECTION 01220 - PROGRESS MEETINGS.....	56
	SECTION 01300 - SUBMITTALS	57
	SECTION 01380 - PRECONSTRUCTION PHOTOGRAPHS	58
	SECTION 01500 - TEMPORARY FACILITIES	59
	SECTION 01560 - SPECIAL CONTROLS	61
	SECTION 01700 - CONTRACT CLOSEOUT	63
	SECTION 02102 - CLEARING AND GRUBBING.....	64
	SECTION 02200 - EARTHWORK	65
	SECTION 02221 - EXCAVATION, TRENCHING AND BACKFILLING	66
	SECTION 02540 - EROSION CONTROL	70
	SECTION 02701 - ROADWAY REPAIR	73
	SECTION 03306 - CONCRETE.....	75
	SECTION 15060 - PIPE AND PIPE FITTINGS.....	77
	SECTION 154030- GRAVITY SEWERS	78
17.00	DESIGN STANDARDS - LANDSCAPING	83
18.00	STANDARD DETAILS: STREETS, STORM DRAIN, SEWER.....	84

1.00 PURPOSE

1.01 General

It is the purpose of these Improvement Standards to provide minimum standards to be applied to improvements and private development projects to be dedicated to the public and accepted by the City for maintenance or operation, as well as improvements to be installed within existing rights of way and easements. These standards provide for coordinated development of required facilities to be used by and for the protection of the public. These standards shall apply to and regulate the design and preparation of plans for construction of streets, highways, drainage, sewerage, street lighting, water system facilities and related public improvements.

Water system design criteria has been established by the water purveyor for Sutter Creek. For specific requirements or specifications contact:

Amador Water Agency (AWA)
12800 Ridge Rd
Sutter Creek, CA 95685
(209) 223-3018

Water lines shall be sized to meet the fire flow requirements of the Sutter Creek Fire Protection District. For specific fire requirements or specifications contact:

Sutter Creek Fire Protection District
350 Hanford St.
Sutter Creek, CA 95685
(209) 267-0285

1.02 Exceptions

It is not possible to anticipate all situations that arise or to prescribe standards applicable to every development. The intent of these Standards is to assist developers, engineers, and contractors toward completion of improvements that will comply with City requirements and be accepted by City for maintenance and operation. The Planning Commission or City Council may impose project specific requirements which may supercede the requirements and standards set forth herein. Any items or situation not included in these Improvement Standards shall be designed in accordance with accepted engineering practice, the applicable Standard Plans and Standard Specifications of the State of California Department of Transportation, and shall be subject to the approval of the City Engineer.

2.00 DEFINITIONS

2.01 General

In these Improvement Standards, the intent and meaning of the terms that are used shall be as defined in State Standard Specifications and as herein specifically noted.

CITY - Shall mean City of Sutter Creek including any special districts administered by the City Council.

CITY ENGINEER - Shall mean the Engineer authorized by the City Council to represent City or their authorized representatives including City Building Official and inspectors under direction of the City Engineer.

CONTRACTOR - Shall mean any person or persons, firm, partnership, corporation, or combination thereof, licensed to perform the type of work involved, who has entered into a contract with any person, corporation, company, special district of the City of Sutter Creek, or his or their legal representative, for the construction of any improvement or portions of any improvement within the City.

DETENTION BASIN - A facility which stores storm water for a relatively short time designed with some type of metered outlet.

DEVELOPER - Shall mean any person or persons, firm, partnership, corporation, or combination thereof, financially responsible for the work involved.

DEVELOPMENT - Shall mean single properties as well as subdivision improvement.

INFILTRATION BASIN - A facility which stores storm water for a relatively short time and is designed to direct storm water to groundwater through permeable soils or ground cover.

LABORATORY - Shall mean any testing agency or testing firm which has been approved by the City Engineer.

SITE IMPROVEMENTS - Shall mean required improvements for projects other than subdivisions.

STATE - As used in the State Standard Specifications or State Standard Drawings, shall mean City of Sutter Creek.

STATE STANDARD DRAWINGS - Shall mean the most recent Standard Drawings and Plans of the State of California Department of Transportation.

STATE STANDARD PLANS - Shall mean the most recent volume of the State of California Standard Plans as issued by the State of California Department of Transportation.

STATE STANDARD SPECIFICATIONS - Shall mean the most recent volume of the State of California Standard Specifications as issued by the State of California Department of Transportation.

ZONING CLASSIFICATIONS - Shall mean those zones established by and as listed in the Sutter Creek Development Code.

3.00 GENERAL REQUIREMENTS

3.01 Plans and Specifications Required

Complete plans and specifications shall be prepared by an engineer for all proposed streets, drainage facilities, sewerage, street lighting, and water distribution system improvements. All plans and specifications for improvements to be accepted for maintenance by the City shall be prepared by an Engineer of the appropriate branch of engineering covering the work submitted. All dedications and easements necessary to accommodate all improvements shall be submitted to the City Engineer for approval and offered for dedication to the City. Possession of a complete set of City approved plans and a valid encroachment permit shall constitute the necessary permits for a Contractor to perform work in the City right of ways or easements. Engineer or his representative shall order the Contractor to cease work on any project if said Contractor does not have properly approved plans in his possession. Contractor shall be duly licensed by the State of California and shall be bonded as required to meet the requirements of the City.

3.02 Phased Improvements

Where the buildout of a development project is divided into phases, land dedications and infrastructure development will be required on a pro rata basis as each phase is developed unless the applicant negotiates an alternative phasing schedule with the City. Each phase of a phased development project shall be designed to minimize the number of instances where streets, water, sewer, storm drain and other utilities will need to be extended for future phases. It is the intent of these standards to create standalone complete phases if possible in all phased development projects.

3.03 Standard Specifications

The Standard Specifications shall be made a part of contract documents by note or reference which shall appear in the Special Provisions and in the General Notes on the plans. The note or reference shall be as follows:

"The Standard Specifications are part of the contract documents of this project and all materials and construction shall be in strict conformance with said Standard Specifications or as authorized by these plans."

3.04 Plan Submittal

Two sets of plans for subdivisions and two sets of plans for site improvements, complete and in accordance with these Improvement Standards and the Standard Specifications, shall be submitted along with any required specifications, computations, test data, and other material required by the City for approval. When the plans are initially submitted to the City, a plan check fee will be required as a deposit to initiate checking of the plans by the City.

Any portion of the required deposit over and above the accumulated costs expended by the City on the development will be refunded to the Developer. Should there be required alterations or revisions to the plans as submitted, one copy will be returned with the required corrections marked or indicated thereon. Plans not prepared in accordance with these Improvement Standards and the Standard Specifications or plans not prepared consistent with the standards of the profession, may be returned unmarked and unapproved.

No plans will be approved nor construction authorized until such times as all appropriate City Official(s) signify approval on the plans. All changes, corrections, or additions required shall be resubmitted to the City for approval as prescribed. At such times when the plans meet the requirements of the City and the plan check and inspection fees have been paid, the plans will be signed and stamped "Approved for Construction." The Engineer shall deliver not less than three complete sets of plans to the City Engineer. Two sets will be retained by the City.

Excepted from approval are any features of the plans that are contrary to or in conflict with any California State Law, City ordinance or resolution, generally accepted sound engineering practice, or standards of the profession; even though such errors, omissions or conflict may have been overlooked in City review of the plans.

3.05 Change in Plans During Construction

Should changes become necessary during construction, the Engineer shall resubmit "red lined" plan sheet prints for approval by the City. Necessary changes shall be clearly shown and dated on the plans. Minor changes, which do not affect the basic design or contract, may be made upon the authorization of the City Engineer. All changes shall be shown on "as-built" plans when the work is completed.

3.06 Contractor and Developer Responsibility

Contractor and Developer are directed to the Construction Safety Orders of the Division of Industrial Safety. Contractor and Developer shall conduct all work in accordance with these standards. Contractor and Developer shall be responsible for all damage arising from any failure to comply with such orders regardless of any action taken by the City or its authorized agents.

Contractor and Developer are directed to the regulatory provisions of the State Standard Specifications. City will assume no costs or liability for complying with these provisions.

3.07 Maintenance Guarantee

Developer or Contractor shall guarantee the entire work required by City to be free of defects in materials and workmanship for a period of one (1) year following the date of acceptance of work by the City. Developer or Contractor shall make, at their expense, any repairs or replacements made necessary by defects in materials and workmanship which become evident within guarantee period. The Developer or Contractor shall indemnify and save harmless the City and officers, agents, and employees of the City against and from all claims and liability arising from damage and injury due to said defects. The Developer shall cause all repairs and replacements to be made promptly upon receipt of written order from the City. Should Developer fail to have

repairs and replacements made promptly, City shall cause the work to be done, and the surety provided therefore shall be claimed for the cost of all such work.

Maintenance guarantee shall be a surety bond or other approved security which shall be delivered to City prior to recording of a final map or other approval requested of City. Said security shall be in an approved form and executed by a surety company or companies satisfactory to City in the amount of ten percent (10%) of approved engineer's estimate of construction costs. Security shall remain in force for the duration of the guarantee period specified. In lieu of providing security as prescribed above, the Developer may provide for the Faithful Performance Bond under agreement to remain in force until the expiration of guarantee periods.

Specific guarantees for periods longer than one (1) year may be specified due to special conditions of materials or workmanship.

4.00 CONSTRUCTION STAKING

4.01 Scope

It is the intent of this section to define the responsibilities of the Contractor regarding the use, maintenance, and replacement of construction stakes. The Developer's Engineer or Contractor shall furnish the stakes and reference points for the improvements relative to the work and shall provide restaking as required by the City as set forth in Section 3.03.

4.02 Control Stakes

Control and reference stakes for all construction work shall be conspicuously flagged. Contractor shall be responsible for the preservation and perpetuation of these points, marks, and stakes. When removal of a control point, mark, or stake is required by construction operations, Contractor shall notify the Developer's Engineer at least two (2) working days in advance of such operations. Developer's Engineer shall perpetuate such control points subject to approval of City Engineer.

4.03 Required Staking

The Developer's Engineer shall provide the stakes and reference marks sufficient to control the work. Staking requirements shall be not less than:

A. Street Grading

One set of slope stakes will be set at fifty (50) foot intervals and twenty-five (25) foot intervals along vertical curves. Reference stakes will be set at an appropriate offset from the top of cut or toe of fill. The top of cut or toe of fill need not be staked. The reference stake will indicate the offset to the top of cut or toe of fill and indicate the cut or fill from the reference point to the top of cut or toe of fill. The reference stakes will indicate the cuts or fills and distances from the top of cut or toe of fill to the subgrade hinge point and centerline subgrade elevation.

At street intersections, the radius points for pavement rounding will be staked. The elevation of the top of the stake will be established and marked on witness lath.

B. Clearing

When slope stakes are not required, clearing stakes will be set on streets and roads. Lath marked "CLEAR" will be set at fifty (50) foot intervals at the clearing limits. Lath will be oriented so the marking faces the centerline of the street or the improvement.

C. Sewer

Sewer trunk lines will be staked on an appropriate offset from centerline at fifty (50) foot intervals on tangents and twenty-five (25) foot intervals on horizontal and vertical curves. All manholes and curve points will be staked on an appropriate offset from the sewer centerline. Stakes will indicate offset to pipe centerline and the cut to the flow line of the sewer pipe. When a flow-line grade is indicated on the plans for a sewer service, a cut to the flow line at the end of the service will be marked on the offset stake or witness lath thereto.

D. Curb and Gutter

Stakes for curb and gutter will be set no more than five (5) feet from the proposed work and at twenty-five (25) foot intervals. Subgrade and **forms shall be checked and approved by the City prior to placing curb and gutter.**

E. Cross Culverts

The ends of all cross culverts will be staked by an offset stake set on the prolongation of the centerline of the culvert. Offset stakes will be marked with a cut or fill to the flow line at the ends of the culverts. The final length of cross culverts shall be determined in the field at the time of staking.

F. Underground Storm Drains

Underground storm drains will be staked in the same general manner as sewer trunk lines.

G. Drain Channels

The centerline of drainage channels will be marked with lath at fifty (50) foot intervals for horizontal alignment only. When vertical alignment is noted on the plans, offset grade stakes will be set at fifty (50) foot intervals and slope stakes will be at twenty-five (25) foot intervals along vertical curves.

H. Finish Subgrade

One set of finish subgrade stakes will be set on centerline at finished subgrade at fifty (50) foot intervals on tangent and twenty-five (25) foot intervals on vertical curve by the Developer's Engineer. An additional set of stakes will be set on hinge points at finished subgrade at fifty (50) foot intervals on tangents and twenty-five (25) feet on vertical curves by Contractor and checked by Developer's Engineer. Any realignment or adjustments of stakes on hinge points will be reset and rechecked as necessary. Developer will be responsible for staking base rock

grade from the finished subgrade once the subgrade has been accepted by the City Engineer. The method of staking shall be approved by the City Engineer.

I. Additional Stakes

Any additional stakes required by the City will be set at the Developer's expense.

4.04 Construction Stake Checking

Should occasion arise where the validity of a stake is questionable, either as to its location, offset, cut or fill marked thereon, Contractor shall notify the City Engineer and Developer's Engineer, who will check the stake or stakes in question. **It shall be the Contractor's responsibility to examine the stakes before commencing operations.** Any stakes found to be in error shall be reset. The Developer shall be responsible for any error in the finished work resulting from questionable or erroneous stakes.

4.05 Construction Staking

When the Developer has a registered civil engineer or licensed land surveyor, other than the engineer who prepared the plans, provide construction staking, he shall provide the City Engineer, in writing, with the name of the individual or firm one week prior to staking of the project for construction. Developer shall be responsible for providing professional engineering services for any plan change which may be required during the construction phase, and for the preparation of revised plans, and preparation of "as-built" plans upon completion of the improvements.

4.06 Lines and Grades

At all points along any grade line shown on the drawings, between the points along any grade line shown on the drawings, and between the points at which the grade elevations are given, the grades shall conform to a straight line except that grading through a vertical curve shall conform to a smooth curvilinear alignment. In any case where grade variation exists, it shall be reported to the Developer and City Engineer.

Contractor shall preserve all stakes and points set for lines, grades, or measurements of the work in their proper place until authorized to remove them by the Developer and City Engineer. All expenses incurred in replacing stakes that have been removed without proper authority shall be paid by the Contractor.

4.07 Utilities

All utilities shall be shown on the plans. The Engineer shall contact utilities early in the planning stage. Prints with the utilities approval shall be submitted to the City. All utilities must be contacted so they can properly plan their relocation work and construction of additional facilities. Engineer shall notify the City Engineer, by letter, when all utility companies have been so notified. Utility company approved plans for underground work in city streets shall be submitted to the City Engineer for review and approval prior to start of work. Utilities shall be clearly identified as existing or proposed.

5.00 PLAN DETAILS

5.01 General

All plans submitted to the City shall be prepared in a manner that will produce legible prints. All line work must be clear, sharp and heavy. Letters and numerals shall be 1/8 inch minimum height, well formed, and sharp. Numerals showing profile elevations shall not be bisected by station grid lines. Computer drafting shall be by clear and legible lettering acceptable to City.

5.02 Plan Content Requirements

The following requirements shall apply to all plans submitted for approval. Engineer shall prepare plans neat, accurate, and comprehensive in keeping with the standards of the profession. Engineers are directed to Caltrans Standard Plans.

A. Title Sheet

On subdivision or improvement plans, exceeding three sheets in the set, a title sheet shall be prepared showing the entire subdivision or project complete with subdivision or assessment district limits, city limits, street names, section lines, corners, and the location within the City. (Minimum scale 1"=500'.) The title sheet shall also include an index of the sheets; Engineer's name, license number, and signature; the date and scale of the drawing; north arrow; and the block for the necessary approval of the City Engineer and other officials. A sample of the City approval block may be obtained from the City Engineer. All sheets shall be 24" x 36".

B. Layout Sheet

The layout sheet (Sheet 2) shall contain thereon the entire subdivision unit on one sheet in skeleton form showing drainage features and sewer and water lines. Drainage pipe, sewer pipe, water lines, and other underground utilities shall each be identifiable from other underground conduits. Appurtenances such as manholes, valves, and drop inlets shall be shown in their proper location. The scale of the project shall be 1" = 100' or 1" = 200'. An index of the plan and profiles sheets shall be shown on the layout sheet.

C. Title Blocks

Each sheet within the set of drawings shall show the sheet title, sheet number, date, scale, and the Engineer's name, signature, and license number.

D. Right of Way

Right-of-way lines, the boundaries of lots fronting on the street, drainage easements, utility easements, planting easements, section lines and corners, land

grant lines, and temporary construction easements both existing and proposed shall be shown on the plans. All right-of-way and easement lines shall be properly dimensioned.

E. Topography

All pertinent topographic features shall be shown such as street lines, curbs, sidewalks, shoulders, location and size of storm and sanitary sewer lines, high water and frequent inundation levels, water lines, gas lines, telephone conduits, other underground utilities, existing structures, houses, trees (6" and larger) and other foliage, traffic signals, street lights, pull boxes, underground electrical conduits, drainage ditches, utility poles, fire hydrants, retaining walls, masonry structures, and all other features in the area which may affect the design requirements for the area. Any tree (6" and larger) which falls within the existing or proposed right of way or easement shall be shown on the cross section when requested by the City Engineer. Permission to remove any tree (not required to be removed by construction) in the City rights of way or easements shall be obtained from the City Engineer prior to removal.

F. Contours, Elevations, and Drainage Plan

Existing contours or supporting elevation data shall be shown on all plans. The Drainage Plan, if required, shall contain contours of the subdivision unit and the immediate vicinity sufficient to indicate the perimeter of areas to be drained by each structure. Calculations supporting the design of drainage facilities shall be submitted with the drainage plan. Scale of plan shall be of sufficient size to clearly show the drainage features and the location of major structures. FEMA established 100 year floodplains shall be identified when applicable.

G. Profiles

Plans shall show the profile of all existing roadway centerlines, existing edges of pavement, existing curb and gutter flow lines, drainage ditches, storm and sanitary sewers. All profiles of proposed improvement shall state centerline elevations at fifty (50) foot intervals and rate of grades, vertical curves and other vertical alignment data. Elevations of any warped surfaces and vertical curves shall be set at twenty-five (25) foot intervals. When required by the City Engineer, the Engineer shall provide centerline profiles and cross section information beyond the limits of the proposed development to facilitate setting proper vertical alignment within the proposed improvement limits.

H. Stationing and Orientation

The stationing on plan and profiles sheets shall read from left to right. Plans shall be so arranged that the north arrow points toward the top or upper 180 degrees of the sheet, insofar as practical.

I. Bench Marks

The bench marks and datum shall be clearly noted on the plans both as to location, description, and elevations. The datum shall be U.S.G.S., NGVD29, NAVD88 or as otherwise approved by the City Engineer.

J. Typical Sections

A typical section, setting out the structural features for each type of facility within the improvement, shall be set forth on the plans.

K. Cross Sections

Cross sections, when required, shall be included with the plans. When, in limited areas, unusual topographic features or special conditions occur that would affect the work, individual cross sections or typical sections may be shown on the pertinent plan sheet.

L. Special Notes

Special notes shall be clearly indicated and it shall be conspicuously noted on the plans that all construction work and installation shall conform to the State Standard Specifications, the City of Sutter Creek Improvement Standards, and that all work is subject to the approval of the City Engineer.

5.03 Plan Format Requirements

All improvement plans shall be prepared on plan and profile sheets, 24" x 36". Scales: Horizontal 1" = 20', 40', or 50'; Vertical 1" = 2', 5', or 10'. Design cross sections plotted on 1" = 5' scale, taken on maximum 50' intervals shall be submitted with preliminary improvement plans or cut and fill slopes shall be shown on the plans. Cross sections shall be plotted with background grid with reference to identifiable base line or centerline.

5.04 Additional Improvements to Be Shown

Storm drainage improvements shall be shown on the street plans. Sanitary sewer and water improvements may be shown on the street plans or separately as indicated above. Street lighting shall be shown separately. Street lighting plans shall be drawn to a scale of 1" = 100' with individual lot dimensions and street dimensions shown. Location of all utilities shall be shown on the "as-built" plans.

5.05 Sign and Striping Plan

Sign and striping plan shall be set forth on a separate plan sheet or detail sheet. Signage and striping shall be consistent with State Standard Drawings, and plan sheets shall contain references thereto.

5.06 Compliance

Plans shall be checked for compliance with these standards and all conditions of approval by the City Engineer. Plan checking deposit shall be as set forth in Section 6.05 of these standards.

6.00 INSPECTION DURING CONSTRUCTION

6.01 General

Any improvement which is intended for future City maintenance responsibility or required by City as a condition of approval shall be constructed to City requirements and inspected during construction by the City Engineer. Each phase of construction shall be inspected and approved prior to proceeding to subsequent phases.

Inspection includes field inspection during the course of construction and materials testing of those improvements over which no other public agency or utility exercises inspection responsibility.

6.02 Notification

The Engineer shall notify the City Engineer when the Contractor first calls for grades or staking. Any improvements constructed without inspection as provided above or any construction contrary to the orders or instructions of the City Engineer shall be deemed not in compliance with City requirements and will not be accepted by City.

6.03 Compliance and Responsibility

The City will inspect the work for ultimate compliance with the specifications but will not be responsible for the conduct of the work itself or the manner in which it is performed. Requirements of State or Federal agencies shall be verified by appropriate agency representatives.

6.04 Inspection Fees

The applicant shall deposit an estimated fee to cover the City's actual cost of plan checking and inspection of the project. This fee may be deposited in two installments. The first installment shall be paid when plans are submitted for checking. The balance of the inspection fee shall be deposited prior to approval of the plans. All other public agency or utility fees shall be paid separately by the developer. The inspection fee deposit shall be determined in accordance with the Fee Resolution adopted by the City Council in effect at the time application is made.

6.05 Inspection Deposit

Inspection deposits shall be placed in a plan check fund and all charges for inspection, as deemed necessary by the City shall be charged against that fund. No inspection work or construction work shall be undertaken when the cost of such inspection or work exceeds the funds remaining in the account for the project.

Whenever the inspection fee deposit is exhausted, the developer shall deposit additional funds for further inspection work. When the total inspection charges are less than the deposit, the balance will be returned to the applicant after the improvements have been certified as complete by the City Engineer and all conditions of approval complied with.

7.00 FINAL INSPECTION

7.01 Clean Up

Upon completion of any improvements which are constructed under and in conformance with these Improvement Standards and prior to requesting a final inspection, the work area shall be thoroughly cleaned of all rubbish, excess material, and all portions of the work shall be left in a neat and orderly condition.

7.02 City Engineer Inspection

Within five (5) working days after receiving a request for final inspection, the City Engineer shall inspect the work. Contractor, Engineer, and Developer will be notified in writing as to any particular defects or deficiencies to be remedied. Contractor shall proceed to correct all defects or deficiencies at the earliest possible date. At such time as the work has been completed, an inspection shall be made by the City Engineer to determine if all defects have been repaired, altered, and completed in accordance with these Improvement Standards. At such time as the City Engineer finds the work acceptable, the City Clerk will be notified and the matter scheduled for City Council approval. The Contractor, Engineer, and Developer will be notified in writing as to the date of final approval and acceptance by the City Council.

8.00 "AS-BUILT" PLAN

8.01 "As-Built" Plan Requirements

One complete set of "as-built" reproducible plans, as prescribed by the City Engineer, shall be submitted to the City Engineer prior to acceptance of the improvements.

Developer's Engineer shall keep an accurate record of all approved deviations from the plans. These are to be utilized with the Inspector's plans for preparing a complete and accurate set of "as-built" drawings for the permanent records of the City. "As-built" plans shall be prepared by the Engineer responsible for the work. Preparation of as-built plans, complete and in accordance with these standards, shall be the responsibility of the Developer.

9.00 IMPROVEMENT AGREEMENTS AND SECURITY

9.01 Improvement Agreement

When project improvements are not completed at the time the Final or Parcel Map is ready for approval by the City Council, the applicant shall enter into an Improvement Agreement with the City. The agreement shall require the applicant to complete all conditions of approval and improvements as shown on the approved improvement plans within the time frame set forth therein.

9.02 Improvement Agreement Security

Applicant's performance under any such agreement shall be secured by a good and sufficient instrument of surety in an amount fixed by the estimated costs of the improvement in accordance with Table II. The estimate of construction costs shall be submitted to the City Engineer for review and approval. Security for City maintained street improvements shall provide that ten percent of the secured amount be withheld by the City for a period of one year after the completion of improvements. The ten percent retention may be used by the City to correct any defects in material or workmanship which become evident in the one year period following completion.

TABLE II			
AMOUNT OF AGREEMENT SECURITY			
TYPE OF SECURITY	PERFORMANCE	LABOR/ MATERIALS	TOTAL
Bonds	100%	100%	200%
Letter of Credit	100%	50%	150%
Bank Deposit (1)	100%	50%	150%
Deposit with City (2)	100%	50%	150%
(1) Savings account assigned to City.			
(2) Deposit in a trust account or a negotiable certificate of deposit with principal payable to the City upon demand.			

9.03 Termination

Termination date of any security shall extend beyond the termination date of the agreement or any extension thereof. Termination date shall be subject to the requirements of the City Council.

9.04 Deposits and Certificates

Bank deposits and certificates of deposit shall be purchased or an account opened so that the principal and interest are payable to the City of Sutter Creek.

When the account or certificate is made jointly payable to the developer and the City, the developer shall submit a negotiable order of withdrawal with the bank book or an endorsed certificate.

9.05 Letter of Credit

The letter of credit shall be extended prior to its expiration date for any extension of time requested.

9.06 Performance and Labor/Materials Bond

Performance and Labor/Materials bonds shall be for the amount set forth in Table II. Performance and Labor/Materials bonds shall be provided by an "admitted California surety."

9.07 Security Release

Security will be released upon request of the project proponent in accordance with the terms of these standards, the Sutter Creek City Code Chapter 17.26, "Improvement Security," and the Improvement Agreement.

9.08 Time Extension

Upon written request by the developer, no less than thirty days prior to the expiration of the agreement, an extension of time may be requested from the City. To receive approval, the developer shall have made a good faith effort to complete improvement requirements, or conditions or circumstances beyond their control such as weather conditions or litigation shall have prevented completion of the improvements. An extension of time of up to one year may be approved, provided the improvement security is adjusted where required.

10.00 DESIGN STANDARDS - STREETS

10.01 General

The Design Standards provide the minimum standards for the design, construction and alterations for all streets, roadways, drainage, utility placement, and all appurtenances thereto. The Design Standards shall consist of the applicable provisions in the Highway Design Manual, the State Standard Plans, and this Chapter.

The City Engineer, at his discretion, may approve or require modifications to the minimum standards for a particular development whenever it appears necessary, reasonable, and proper. Exceptions to these standards will not be allowed unless the request is accompanied by written justification and certification by a licensed engineer that traffic safety is not compromised.

The City Engineer shall be the final authority on all questions which may arise as to the interpretation of the Design Standards. The City Engineer's decision shall be final and he shall have authority to enforce and make effective such decisions. Appeals of the City Engineer's decisions shall be in writing to the City Clerk pursuant to Sutter Creek City Code Chapter 17.31, "Appeal."

10.02 Street Classifications

Streets shall be classified as arterial, collector, local or private streets. Street classification shall be as follows:

- Arterial:** A through street collecting traffic from minor and collector streets and classified in the Circulation Element of the City as an "arterial" street.
- Collector:** A primary street that collects traffic from local streets and is classified in the Circulation Element of the City as a "collector" street.
- Local:** A local street that collects traffic along its frontage.
- Private:** A local street not accepted for maintenance by the City.

10.03 Grades, Cross Slope, and Intersections

The criteria for road grades and cross slopes shall be as follows:

- A. Minimum grade on new streets shall be 1.00 percent.
- B. Minimum grade of gutter section constructed on existing street shall be 0.50 percent with approval of City Engineer.
- C. Standard cross slope on new streets shall be 2.0 percent.
- D. Minimum cross slope on widening shall be 1.5 percent.

- E. Maximum cross slope of the traveled way shall be 3.0 percent.
- F. The roadway minimum vertical curve length allowable at the intersection of two grades shall be fifty (50) feet. Vertical curves may be omitted at intersections where the algebraic difference in grades does not exceed 2.0 percent.
- G. Streets shall have a desirable maximum grade of 15 percent. Steeper grades may be authorized where justified and approved by the City Engineer. Decision of the City Engineer concerning grades in excess of 15 percent shall be based upon local conditions.
- H. When two streets intersect, the minor street shall not have a grade greater than 7.0 percent for a minimum distance of forty (40) feet measured from the curb line of the intersecting street, except in unusually rough terrain, as determined by the City Engineer. The centerline of the lesser intersecting street shall meet the crown slope at the projected lip of gutter. Crown slope of the major street may be reduced to 1.0 percent within the intersection when approved by the City Engineer.

10.04 Design Speed

Streets shall be based upon design speeds as follows:

Classification	Design Speed
Arterial	45 MPH
Collector	35 MPH
Local and Private	25 MPH

Cul-de-sac streets, less than 300' in length, may be designed for 15 miles per hour.

Streets with grades in excess of 5 percent intersecting highways or arterial roads shall have a minimum of thirty (30) feet "storage" area from the edge of pavement of the primary road to the beginning of vertical curves (BVC).

10.05 Geometric and Structural Sections

Geometric and structural sections for proposed improvements shall comply with the following:

- A. Cross gutters will be allowed only with the specific approval of the City Engineer. Cross gutters shall be concrete with rebar reinforcement.
- B. The curve data for all centerline curves shall be computed and shown on the plans. Where unusual alignment problems exist, less than minimum curve radii may be allowed when approved by the City Engineer. Property lines radius at curb returns for intersecting streets shall be not less than twenty (20) feet.

- C. The property line radius for cul-de-sacs shall be fifty (50) feet unless otherwise specified by the City Engineer. A curve of twenty (20) foot radius shall connect the tangent and the fifty (50) foot radius curve. (See Section 18.00, Standard Details.)
- D. Cut and fill slopes: Fill slopes shall be 2:1 or flatter and cut slopes shall be 2:1 or flatter depending upon the material encountered. Desired slopes are 3:1 where compatible with other project design criteria. This condition may be modified when engineering studies indicate the need for flatter slopes or when stable slopes can be maintained on steeper grades and are approved by the City Engineer. Slope rounding shall be provided where the height of cuts or fills exceeds six (6) feet.
- E. Clearing Right of Way: All trees and all brush shall be removed from the road right of way when within a distance of seven (7) feet from the edge of the paved surface of the roadway regardless of the width of the paved section. The right of way shall be cleared to a minimum of three (3) feet beyond any cut or fill slope. At intersections, clearing may be required to the property line for a distance of 100 feet from the centerline of the intersection when deemed necessary to provide safe sight distance for approaching traffic.

Tree removal shall be consistent with Sutter Creek City Code Chapter 13.24, "Trees and Landscaping," and may be restricted by project specific conditions. The clearing limits of this section may be modified to comply therewith.
- F. Driveways: In areas where sidehill cuts and fills exceed three (3) feet or where damage may occur to public right of way during future driveway construction, driveways shall be graded into each lot at the time of grading for the roadway. All material from driveway construction shall be disposed of consistent with the grading plan or applicable chapter of the California Building Code.
- G. Access Roads: All roads to be accepted for dedication and maintenance by the City shall be paved to the boundary of the subdivision. Private road approaches that encroach into a City maintained street shall be constructed in accordance with these standards.
- H. Minimum allowable roadbed structural section shall be in accordance with Standard Detail ST-1.
- I. Pavement thickness and total structural section shall be designed on the basis of resistance factor "R" determined in accordance with State of California, Department of Transportation, California R-value determination or other approved method.

- J. The thickness of various structural components shall be determined by the tables, charts, formulas, and procedures contained in Chapter 600 of the State Highway Design Manual with a factor of safety of 1.2, and shall be approved by the City Engineer.
- K. The minimum traffic index used for structural section design shall be as follows:

<u>Street Type</u>	<u>Traffic Index</u>
Arterial	8
Collector	6
Local	5
Cul-De-Sac	4.5

- L. Where new paving meets existing paving, all low areas shall be paved as directed by City to maintain a uniform cross slope and provide required drainage improvements.

10.06 Testing of Materials

Testing of materials for compliance with these Standards shall be performed in accordance with the methods set forth in the State Standard Specifications. Signed copies of all test results required shall be submitted to the City Engineer. Test results shall show clearly the name of the individual and the firm performing the tests, as well as the name of the project, the date of sampling, and the date of testing.

The tests indicated in the State Standard Specifications will be required at locations and frequencies determined by the City Engineer.

10.07 Right of Way

Minimum right-of-way widths, to be dedicated in fee title to the City for all newly constructed streets, shall be as set forth in these Standards for the type of street under consideration. (See Section 18.00, Standard Details.) In no instance, without specific approval of the City Council, shall a street have a right-of-way width which is less than fifty (50) feet. Right-of-way requirements for widening at intersections shall be as approved by the City Engineer.

All proposed utilities (including but not limited to water, sewer, and storm drain) shall be contained within said dedicated right of way. If utilities are proposed to be installed outside of the right of way, developer shall submit sufficient documentation why the facilities must be installed in their proposed location for City approval.

10.08 Signing and Barricades

Street name signs shall be furnished and erected at all intersections. Street name signs shall conform to requirements of these Standards. Street names shall appear on plans submitted for approval.

Where phased improvement covers a portion of the ultimate improvement and where an improved street is proposed to be extended in the future, the improvements shall include a permanent-type barricade at the end of such a street to extend completely across the right of way to serve as a warning to the public. The barricade shall be constructed, painted, and signed in accordance with the Standard Specifications and Standard Plans. Gates may be required where streets stub into areas where ingress and egress is required.

11.00 DESIGN STANDARDS - STORM DRAINAGE

11.01 General

These standards shall serve as a guideline for drainage system design and indicate minimum design standards acceptable to the City.

Improvement projects shall be protected from inundation, flood hazard, sheet overflow, and ponding of storm water, springs, and other surface waters. The design of improvements shall be such that water accumulating within the project will be carried away from the project without injury to adjacent improvements, residential sites, or residences to be constructed on sites within the project, or to adjoining areas. Water accumulating within the project shall be carried to storm drainage facilities or to a natural water course by closed conduit or open channel, shall not exceed pre-development flows, and shall meet the design standards herein set forth.

Drainage systems within the project shall accommodate anticipated future development (consistent with the General Plan) within the drainage basin. Off-site drainage facilities shall be adequate for ultimate development of the drainage basin. Diversion of natural drainage will be allowed only within the limits of the proposed improvement. All natural drainage must enter and leave the improvement area at its original horizontal and vertical alignment unless an agreement, approved by the City, has been executed with the adjoining property owners. All concentrated drainage leaving the boundaries of an improvement area shall be connected to existing drainage ways approved by the City Engineer.

Where a subdivision is subject to flood hazard, the developer shall provide flood control works, drainage facilities, or other improvements sufficient to provide all structures or building sites, both existing and proposed, with 100-year flood protection and compliance with the Sutter Creek City Code Chapter 15.20, "Flood Plain Management."

Street improvements shall include adequate provisions for storm drainage. Adequate storm drainage shall consist of a system of underground piping, generating self-scouring velocities and leading to a disposal point which is workable under conditions of heavy rainfall and runoff.

Special design problems involving pump stations, infiltration basins, on-site retention, or other unusual features not covered herein, will require individual study and approval. Pump stations will not be allowed except where special circumstances warrant consideration.

11.02 Classification of Storm Drains

Cross Culverts - Drainage culverts transporting runoff across roadways into open ditches or natural drainage courses.

Driveway Culverts - Drainage culverts transporting runoff across driveways.

Onsite Drainage Facilities - All surface drains and underground drainage pipe within the development.

Offsite Drainage Facilities - Facilities required to carry storm water from the proposed project to a natural drainage course or existing conduit.

Modification of storm drain classifications may be required by special conditions. Any modification of classifications will be resolved on an individual basis by the City Engineer.

11.03 Alignment

The location of storm drainage pipelines in new streets shall be under or adjacent to the curb and gutter parallel to roadway centerline. Pipes placed under curb and gutter shall have minimum clearance of 0.5 feet between the bottom of gutter section and top of pipe.

11.04 Lines

Lines shall be as near parallel with the centerline of streets as possible. Angular changes shall not exceed 90 degrees. Open ditches, lined channels, swales, and flood plain areas shall be maintained as nearly as possible in their existing alignment. When an open ditch, other than a roadside ditch, is to be constructed parallel to an existing roadway, the ditch shall be constructed outside the proposed right of way of the ultimate street development.

11.05 Easements

Drainage conduits and channels, when not located in a public street, road or alley, or within an existing public drainage easement, shall be located in a recorded or dedicated public utility / public facility easement (PUE/PFE).

Dedications necessary for construction on private property shall be completed prior to acceptance of improvements by the City. Where a minor improvement of a drainage channel falls on adjacent property, a right of entry shall be obtained from the property owners, and a copy of the right of entry shall be submitted to the City prior to approval of the improvement plans.

Easements for closed conduits shall have a minimum width of fifteen (15) feet. The centerline of the pipe shall be not less than five (5) feet from the easement limit. Pipe may reverse sides of the easement at angle points.

Easements shall provide sufficient widths for vehicle access and working space.

For pipes exceeding 24" in diameter or trenches exceeding five (5) feet in depth, the easement shall have additional width to provide working space as required by the City Engineer.

Easements shall be provided for all ditches, culverts, and conduit systems whether constructed as newly built improvements or as rebuilt improvements and shall adequately meet the minimum width specified herein.

11.06 Natural Drainage Courses

All natural drainage courses within the boundaries of an area to be improved shall be provided with drainage easements extending the full length of the drainage courses within the improved

area. The width of such easement shall be determined from the limit of the 100-year flood plain. A natural drainage course is defined as an existing drainage way having specific sides and bottom, but may not have year-round flow.

11.07 Drainage Study

A drainage study consisting of calculations and a drainage map shall be submitted with all improvement plans requiring storm drain improvements. The following information shall be included in the drainage study:

- A. A drainage map that depicts onsite facilities, offsite drainage adjacent to the project, and all natural water courses within the project limits.
- B. All existing drainage structures shall be checked to see that sufficient capacity exists to safely pass the increased runoff.
- C. Calculations as set forth in Section 11.09.

11.08 Drainage Map

A drainage map shall be submitted with each set of improvement plans and shall reflect the following criteria:

- A. Must be of adequate scale and accurately and clearly show contour lines and reference to the datum.
- B. All individual watershed areas shall be clearly delineated on the plan.
- C. Concentrated storm flow patterns shall be delineated on the plan.
- D. The quantity of water arriving at each structure, pipe or ditch from a 10-year and a 100-year frequency storm shall be calculated and shown on the plan.
- E. The size, type, and location of conduit proposed.
- F. Channel dimensions and water surface profile computations for 100-year storm when required.
- G. Detention facility details, size, location, and discharge structure location.

11.09 Calculations

One set of drainage calculations shall be submitted with each set of improvement plans. The calculations shall be submitted by a California registered civil engineer and shall conform to standard engineering practice.

Drainage calculations shall be checked and approved by the City Engineer. Drainage calculations may be from any accepted engineering method. The City will check flow determinations by the rational method.

Storm drains shall be designed to pass a 10-year storm with no head. The 100-year storm must be carried within drainage facility or roadways with no potential for property damage. All major structures shall be designed to pass the 100-year storm.

Runoff factors for the rational method shall be not less than the following:

<u>Land Use</u>	<u>Runoff Factor "C"</u>
Rural Residential	0.50
Single Family Residential	0.50 – 0.60
Multi-Family Residential	0.60 – 0.75
Commercial and Industrial	0.75 – 0.95

Time of concentration (t_c) shall be determined by accepted methods. A 10 minute minimum may be used for unsurfaced basins.

Rainfall intensities shall be in accordance with the "Rainfall Intensity Chart," (See Standard Detail SD-6) and shall be not less than:

t_c	i_{10} (in/hr)	i_{100} (in/hr)
10 minutes	2.5	3.4

11.10 Closed Storm Drain Systems

Closed conduits shall be of cast-in-place concrete pipe, precast reinforced concrete pipe, non-reinforced concrete pipe, or smooth wall PVC pipe as set forth in the Standard Specifications. The specific type of pipe or alternate pipes to be used in the development shall be shown on the plans and be subject to approval of the City Engineer.

The minimum pipe diameter allowable on any storm drain trunk line shall be 15 inches for onsite development. The minimum pipe diameter allowable on any drop inlet laterals shall be 12 inches and laterals shall connect directly to a manhole or other drop inlet.

The minimum velocity in closed conduits shall be 2 f.p.s. when flowing at a depth of 0.8 D, (D = pipe diameter).

Minimum cover requirements are shown on Standard Drawings. At locations where the minimum cover requirements cannot feasibly be obtained, conduit shall be backfilled with cement slurry backfill or other method of pipe protection approved by the City Engineer.

11.11 Open Channels

Open channels shall consist of concrete-lined channels, rock slope protection lined channels, or earth channels with approved fabric liners. Open channels shall be designed to the following criteria:

Minimum Velocity - 2 f.p.s.

Maximum Velocity

1. Unlined channels - 6 f.p.s.
2. Lined channels - 10 f.p.s.
3. Paved invert channels – 8 f.p.s.

All channels with earth sides shall have freeboard of not less than 1.5 feet at design capacity for a 10-year storm. All lined channels shall have freeboard of not less than 0.5 feet at design capacity for a 100-year storm.

In existing channels, all abrupt changes in alignment or profile and all underbrush and debris, which restricts flow, shall be removed, trimmed, or otherwise improved.

All open channels shall pass the 100-year storm without the potential for property damage.

11.12 Drainage Structures

Drainage structures shall comply with the following specifications:

Manholes - Manholes shall be standard precast concrete. Cast-in-place type manholes may be used where required. Where special manholes or junction boxes are required, the design shall be approved by the City Engineer. In no case will junction boxes be allowed which are less than twenty-four (24) inches (inside dimensions). Manholes shall have a forty-eight (48) inch inside diameter.

Manholes shall be located at junction points and changes in conduit size. Manholes shall be placed at the BC and EC of all curves and on 300-foot maximum intervals along the curve.

Manholes, junction boxes or inlets shall be placed at intervals not to exceed 400 feet. All manholes and junction boxes other than inlets shall have standard manhole covers, as shown in Standard Detail SD-2. Manholes will not be allowed in gutter flow lines.

Drop Inlets (DI) - Drop inlets shall be open curb-face types as shown in the Standard Drawings or other approved inlets.

Drop inlets shall be spaced so that the length of flow in the gutter does not exceed 600 feet. The depth of the flow in the gutter shall not exceed 0.35 feet for a 10-year storm. Outfall pipes shall accommodate the design runoff taking into consideration bypass flow from upstream inlets.

Junction Boxes - Junction boxes shall be constructed of reinforced concrete or precast concrete. Minimum wall thickness for reinforced concrete junction boxes shall be 6 inches.

The inside dimension of junction boxes shall be sufficient to provide a minimum of three inches clearance on the outside diameter of the largest pipe in each face. All junction boxes shall be rectangular in shape unless otherwise approved by the City Engineer. Junction boxes deeper than four feet shall have a minimum inside dimension of 48 inches.

Headwalls, Wingwalls, Endwalls, Trash Racks, and Railings - All headwalls, wing-walls, and endwalls shall be considered individually and shall be, in general, designed in accordance with the Standards and Specifications of the California Department of Transportation and the requirements of the City.

Trash racks shall be provided where, in the opinion of the City Engineer, they are necessary to prevent clogging of culverts and storm drains or eliminate hazards. Trash racks shall conform to the requirements of the City Engineer. Temporary trash racks will be allowed where pipe will be extended in the near future.

On cross culvert drains, flared-end sections shall be used where required by the City Engineer.

Guardrails may be required by the City Engineer at culverts, headwalls, and box culverts and on steep side slopes. When so required, the railing shall be installed in accordance with the requirements of the current edition of the California Building Code or State of California, Department of Transportation.

Pipe used as cross culverts to open ditches may be corrugated steel.

Detention Basins - Storm water detention basins shall be provided with any proposed development which would increase offsite flows in order to limit said flows to pre-development levels. Basins may be considered a permanent means for handling peak storm runoff flows. A plan outlining the proper maintenance and/or abandonment of the basin in the future shall be provided for approval.

Basins shall be constructed such that the collection system drains into the basin by gravity. Design criteria shall be as follows:

Design Storm: 100 year, 24 hour

Basin volume shall be calculated by $V = (CAR)/12$ where:

V = Basin Volume in Acre Feet

C = Runoff Coefficient (Section 11.09)

A = Contributing Area in Acres

R = Total Rainfall in Inches for the Design Storm (100 Year, 24 hour event in inches)

Freeboard = 2 ft minimum

The volume shall account for a constant outflow not to exceed the pre-development peak runoff rate.

Alternate methods for volume calculations are subject to approval of the City Engineer.

12.00 DESIGN STANDARDS – SEWER SYSTEMS

12.01 Introduction

These design criteria shall govern the engineering design of sanitary sewer systems which will be dedicated to the public and accepted by the City of Sutter Creek (COSC) for maintenance and operation and those systems designed for COSC by its consultants.

It is the intent of these criteria to provide a sewerage system that will dependably and safely convey the peak sewage flows by gravity, where possible, to a point of existing effluent disposal all with minimum maintenance and operational costs to COSC.

Developer shall furnish, without cost to COSC, all intrinsic and auxiliary components for maintenance and operation as necessary to provide said complete system.

12.02 Regulatory Standards

Pertinent requirements of the following agency standards, including all changes thereto, shall be considered and complied with, except that in the event of conflict, the stricter design criteria shall govern.

1. Laws and standards of the State of California Department of Public Health.
2. The Porter-Cologne Water Quality Control Act and the California Regional Water Quality Control Board, Central Valley Region.
3. Ordinances of the City of Sutter Creek
4. Others as appropriate.

12.03 Design Procedure

A design for each project proposed to be constructed under COSC Agreement shall be submitted to and approved by, the City Sanitary Sewer Engineer. In addition the following requirements are applicable.

1. An engineering report on the development of the site shall include, but not be limited to, soils survey, geology, ground and surface water hydrology, water supply, liquid waste disposal, probably population densities, effects of construction and other development activities on the existing environment and conformance with the master regional or City plans.
2. A Master Plan relating to the disposal of wastes anticipated from the ultimate development, shall conform to the regional or City Master Plan for sewage disposal. Stage development may be acceptable for some components of the system if such stage development can be proved financially feasible and if approved by COSC.
3. If treatment plant expansion is required to accommodate new development flows, a report shall be filed on the proposed waste discharge in COSC's name by the Owner,

accompanied by the appropriate filing fee and pursuant to Section 13260 of the State Water Code to the Regional Water Quality Control Board, Central Valley Region.

COSC will provide one CD containing Standard Details to the Design Engineer for development of the Design drawings.

Preliminary Design. A preliminary design shall be submitted for “Planning Approval” and shall be submitted in the form of a map and table relative to the sewerage system.

The Map shall show the following:

1. Location of project.
2. Tributary areas outside project.
3. Adjacent areas.
4. Contours over complete map (ten (10) foot minimum).
5. Line layout and preliminary pipe size, manholes.
6. Predicted average and peak flows at major junction points, including flow coming from outside the project area.
7. Direction of flow.
8. Zoning used to predict flows.
9. Special areas such as hospitals, schools, large office buildings, etc.
10. Boundaries of areas within the project which are tributary to points of major flow.
11. Location and sizing of major system components, including sewage pumping facilities if included in the project.
12. Electrical & telemetry details.

The Table shall include the following in Tabular Form:

1. Areas tributary to points of major flow.
2. Zoning within each area.
3. Predicted flow from each area.
4. Infiltration flow.
5. Peaking factors.
6. Cumulative flow.
7. Pipe size and slope.
8. Equations used and references.
9. Sludge disposal recommendations.

Final Design. The final design shall be an expansion of the “Planning Review” preliminary design in such detail as to verify all preliminary sizing of facilities and to size those facilities not included in the preliminary design. All such final design calculations shall accompany the construction plans and specifications for the review leading to the plans being “Released for Construction.”

12.04 Benefiting Areas Included Within Project Boundaries

A parcel or area which benefits **and participates** in a project, but is not included within the project boundaries shall have a note to this effect placed on the overall project map and on the plan and profile sheet if the parcel appears thereon. Parcels not so noted which make use of a project's facilities after the project's completion will be required to pay an "expansion fee" prior to such use.

12.05 Calculations

Gravity Pipeline Flow. The Manning formula shall be used in the hydraulic study of the system, using an "n" value of 0.013 or the value recommended by the pipe manufacturer, whichever is higher.

Pressure Pipeline (Force Main) Flow. The Hazen-Williams formula shall be used in the hydraulic study of the system, using a "C" value of 140 or the value recommended by the pipe manufacturer, whichever is lower. Design shall provide for adequate aeration and odor control. The minimum velocity at design flow shall be not less than three and one-half feet per second (3.5 fps).

12.06 Average Flow Determination

Zoning. Flow determination shall be based upon the most recent or proposed zoning. The minimum population density in areas of potential development shall be equivalent to that of single family zoning. The area shall be examined for trends toward population concentration and, if found, an estimate shall be made of the probable extent of such concentration. This estimate shall be used as the basis for determining flow. All calculations shall assume ultimate development, except where a stage concept has been specifically approved by COSC.

Residential Living Units.

1. Design population per living unit:
 - Developments of 100 living units and less -3.5
 - Developments of greater than 100 living units -3.0
2. Average flow: Residential living units – 75 gals. per person per day.

Commercial, Industrial Development. Every attempt should be made to base flow requirements on specific development plans in consultation with the City Sanitary Sewer Engineer.

Schools. The flow shall be determined by the following method:

Flow shall be based on ultimate design student population plus administration, teaching and operation personnel.

Average Daily Flow (ADF). Average Daily Flow shall be determined for tributary areas by multiplying the sum of the area(s) design population by the per capita daily flow requirements, as determined above, plus any commercial, industrial, school, etc., contribution(s).

12.07 Design Flow (Peak Flow, or PF)

Average Daily Flow (ADF), as determined above, multiplied by peaking factors of 4.0 for laterals and 4.0 for outfall sewers. The recommended Infiltration Design Rate is 200 gallons per inch diameter per 5,000 feet per day or 40 gallons per inch per 1,000 feet per day or as approved by the City Sanitary Sewer Engineer.

12.08 Pumping Station Design

All phases of pumping station design shall be closely coordinated with COSC. In general, such facilities shall include all necessary components and amenities as required by COSC to ensure a complete, automated, operating facility which will lend itself to minimum maintenance and operational costs.

Auxiliary power shall be provided as required to prevent pump station overflow and operate pumping stations during power outages and shall automatically activate when a power outage occurs.

Pumping Unit. Shall approximately “pace” the expected flow pattern and shall be capable of providing the maximum design flow with the largest pumping unit out of service. All telemetry and electrical shall be compatible with existing COSC equipment.

Access. All weather, asphalt paved access with twelve (12) foot minimum width shall be provided to all pump stations. All pump stations shall be fenced with 6 foot high chain link fencing with 3 strand barbed wire at top. A ten (10) foot wide rolling, locking gate shall be provided in fence.

Structures. Shall provide protection against weather and vandalism, shall be designed to blend architecturally with the character of the Development and shall provide maximum efficiency and minimum operational and maintenance costs to COSC. Access to lower or higher structure levels shall be by inside stairways. Structures shall be multi-purpose wherever practicable. Toilet and sink facilities will be provided where required by the COSC.

Metering, Recording and Monitoring Equipment. Metering, recording and monitoring equipment shall be provided at all pumping stations. Auto-dialer and alarm equipment shall be required at all pumping stations and will be purchased and installed from COSC vendor.

Generally, but not necessarily limited to, requirements are as follows:

Pumping Stations

1. Flow meter and recorder.
2. Auto-dialer and alarm equipment.

Design Flow Rate. Pumping stations shall be designed utilizing peak flow rate.

Odor Control. Pump stations shall be provided with odor control systems. The preferred system is an active air blower and odor bed absorption system.

12.09 Collection System

Design Flow Rate. Pipe capacity shall be adequate to carry the design flow rate from the entire tributary area (even though said area is not within the project boundary), at the design velocity and, unless the line is designated as a force main, without surcharge on the pipelines.

Pipeline Velocity. Minimum velocity shall be two (2) feet per second (fps) when the pipe is half full or full, unless the City Sanitary Sewer Engineer has approved a specific exemption.

Following is a table of slope vs. diameter when the velocity is two (2) fps with the pipe half full or full.

<u>Diameter, inches</u>	<u>Slope, foot per foot</u>
6	0.0050
8	0.0035
10	0.0025
12	0.0020
15	0.0015
18	0.0012

Minimum Size Sewer Lines. Minimum size of collection lines which serve single family or duplex development shall be six (6) inches in diameter. Schools, commercial, industrial and multiple residential shall be served by lines eight (8) inches in diameter, minimum.

Exceptions: COSC approved Innovative and Alternative projects.

Sewer Line Location and Alignment.

1. **Location.** All sewer lines shall be designed to be installed within the paved portion of the roadway, normally six (6) feet from the right-of-way center line and parallel with the center line whenever possible, or in a public easement. All locations within existing road right-of-way shall be approved by the City Director of Public Works. If it is necessary to install a sewer line within a private road, the easement shall be the width of the paving plus one (1) foot on each side or fifteen (15) feet, whichever is larger.

2. **Horizontal Alignment.** Alignment shall be parallel to the street centerline wherever possible. Minimum radius for sanitary sewers six (6) inches through ten (10) inches in diameter shall be 200 feet unless a larger diameter is required by the proposed pipe material and/or pipe joint. A larger radius shall be used whenever practical. Pipe length/joint deflection

shall not exceed manufactures' recommendations. A manhole shall be placed at any abrupt change in alignment.

3. **Vertical Alignment.** Maximum deflection for vertical curves shall be ¼ inch per foot. A manhole shall be placed at any abrupt change in grade. Elevation shall be shown on the plans at twenty-five (25) foot intervals throughout the length of vertical curve.

4. **Typical Cross Section.** COSC Standard Details show typical pipe locations within roadways and minimum clearance between pipe lines.

12.10 Trench Loading

Deflection Equation. The Marston formula shall be used in determining pipe loading.

Deflection Limit. Design deflection of flexible pipelines shall be limited to five (5) percent.

Bedding Types. Bedding types shall be as per COSC Standard Details. Bedding type shall be as necessitated by height of cover over the pipe, trench width, pipe strength and other factors used to determine safe piping loading. Concrete bedding shall require specific approval of the City Sanitary Sewer Engineer before use. These bedding types are intended primarily for emergency field use and their use shall normally not be specified on the plans.

12.11 Sewer Structures

Manholes. Manholes shall be precast conforming to current ASTM Spec. No. C-478 with ASTM C-923 Resilient Connectors (See Standard Details). Manholes shall be placed at all intersections of sewer lines, other than sewer service connections and at the ends of all permanent lines 150 feet or more in length. Maximum spacing of manholes shall be 300 feet. All manholes, from which future sewer line extensions are anticipated, shall have a pipe stub planned and installed at the grade and direction of the anticipated sewer extension. Between manholes, the following combinations of vertical and horizontal curves will be allowed; two (2) horizontal and one (1) vertical curve or two (2) vertical curves and one (1) horizontal curve.

The average hydraulic grade line of any pipe which flows into a manhole shall be one-tenth (0.10) foot minimum above the average hydraulic grade line of the exit pipe. When the major conduit, based on flow, passes through a manhole with less than twenty (20) degrees deflection, the one-tenth (0.10) foot differential between hydraulic grade lines will not be required for the major conduit. The average hydraulic grade lines shall be derived from design flows based upon one hundred (100) percent development of the tributary areas. The crown of the exit pipe, when larger than twelve (12) inches, shall never be higher than the crown of pipes entering the manhole.

A manhole shall be required at the terminus of any collection line terminating within a cul-de-sac.

The minimum inside diameter for manholes shall be:

<u>HEIGHT IN FEET</u>	<u>INSIDE DIAMETER IN FEET</u>
≤8	4
>8 and ≤12	5
>12	6

Drop Connection. In general, the use of drop connections **will** be approved by the City Sanitary Sewer Engineer only. Free drops from an incoming collection line or service to the bottom of the manhole **will not** be permitted and shall be eliminated by use of a drop connection, vertical curve or increased slope of the incoming lateral.

Flushing Branches. A flushing branch (cleanout) may be used in-lieu of a manhole at the end of any line less than 150 feet long.

12.12 Sewer Services The sewer services shall extend from the collection line to the edge of public right-of-way or edge of easement. Sewer services shall extend one (1) foot beyond the edge of pavement of any private road. Easements of adequate width to accommodate the services shall be provided. A plan and profile of any sewer service shall be supplied to the City Sanitary Sewer Engineer upon request.

Minimum Size. Normal service sewer size to each lot is four (4) inches. Schools and other developments expected to contribute high sewage flows shall be served by six (6) inch or larger service sewers. In addition, sewer services shall be sized according to requirements of the Uniform Plumbing Code. A six (6) inch service sewer and larger services shall be connected to the collection line by use of a manhole.

Tapping Existing Lines. The Owner shall make all service sewer taps into existing collection lines upon application for permit and payment of required fees. COSC shall inspect all taps. A note of this effect shall be placed on all plan sheets which require such tapping.

Connection to Trunk Lines. Service sewers shall **not** connect to trunk sewers twelve (12) inches diameter and larger without the written approval of COSC.

Service Location and Depths. Unless specifically requested otherwise by the property owner, service sewers shall be placed on the low side of any typical subdivision lot. Consideration shall be given to trees, improvements, etc., so as to minimize interference when service sewer is extended to the proposed building.

The Consulting Engineer shall verify the adequacy of the normal service sewer depth at the edge of easement or right-of-way, to service the intended parcel at the point of anticipated structure location. The Consulting Engineer shall designate the invert elevation of the service sewer at the edge of the right-of-way or easement on the construction plans, whenever the required depth is greater than three (3) feet.

Clean Out. A four (4) inch clean out will be placed at the property line on all sewer service laterals.

Backflow Device. A sewer backflow device shall be installed on all sewer services and shall be located at or near the property line.

Grease Traps. Grease traps will be installed at all service connections (commercial and industrial) as required and sized by the Uniform Plumbing Code. See City of Sutter Creek F.O.G. Ordinance for additional requirements (SCMC 14.04.070).

Pumped Service. Pumped services will be permitted only on a very limited, individual basis.

Providing Service Sewers. When sanitary sewers are part of new subdivision construction, a service sewer shall be constructed to each parcel.

In developed areas, a sewer service shall be provided to each parcel which contains a source of sewage. A property owner's request for service shall be honored whenever practical. Parcels which have two or more sources of sewage must have an independent service sewer provided for each sewage source which can be separated from the rest of the parcel and sold. A service sewer shall be provided to each subdivision lot or lot similar as to size and possible development. At an early stage of design, the Consulting Engineer shall send every property owner affected by the proposed work a questionnaire requesting, in writing, the owner's preferred service sewer location. In absence of a response to this questionnaire, the Consulting Engineer shall provide a house service as required by this Section. In addition, when the service sewers are staked immediately prior to construction, each property owner shall be given notice that he should look at the staked location of his service sewer and, if not satisfactory, immediately notify the Consulting Engineer. The date of notification by the property owner, method of notification, nature of change and other pertinent information shall be furnished to COSC.

12.13 Creek Crossings

Crossing details of pipe, pier, anchorage, transition couplings, etc., shall be shown upon a detail sheet of the plans in large scales.

Ductile iron pipe shall be used under the full creek width plus ten (10) feet on each side. All soft or organic material shall be replaced with select imported backfill. Special care shall be used to provide a firm base for the pipe bedding. Full concrete encasement is required.

Any proposed crossing above the creek bed must be approved by the city Sanitary Sewer Engineer.

Calculations shall be submitted which clearly indicate the design of the pipe and supports regarding impact, horizontal and vertical forces, overturning, pier and anchorage reactions, etc.

12.14 Force Mains

Design shall be closely coordinated with COSC. Design criteria generally shall be as contained in Section 12.05, with due regard for the characteristics of the sewage to be conveyed.

12.15 Regulations Relating to Sanitary Hazards

All construction shall conform to applicable regulations relative to safeguarding the public health, particularly the regulations relative to cross-connections as established by the California Administrative Code, Title 17.

In designing the collection system, it is intended that twelve (12) feet be the minimum horizontal distance between parallel water and sanitary sewer lines and that the water main be at least twelve (12) inches higher. When crossing a sanitary sewer force main, the water main shall be a minimum of twelve (12) inches above the sewer line.

Construction of sewers across areas that are frequently saturated or have springs or which are within 25 feet of the 100-year high water line of a lake, reservoir or stream, or within 25 feet of an irrigation canal, should be avoided whenever possible. Construction in these areas may be required to meet the standards of Section 12.13, Creek Crossings, or other special requirements may be required to protect the water quality.

12.16 Locator Wire

All runs of non-metallic pipe shall have a No. 10 AWG solid, soft drawn copper wire with Type UF insulation. Locator wire shall be grounded with a ground rod at the end of a pipe run.

13.00 CONSTRUCTION STANDARDS - STREETS

13.01 Lines and Grades

Attention is directed to Section 4.00, "Construction Staking," of these Improvement Standards. Construction staking to be supplied by the Engineer shall consist of horizontal and vertical location of curb, gutters, valley gutters, and storm drains as determined by the Engineer. Flow line, and grate and rim elevations of drop inlets and junction boxes shall be staked with offsets. All supplemental construction staking required by the Contractor shall be supplied by the Contractor. Engineer may revise curb and gutter alignment in the field to avoid tree root structure or conform to existing improvements.

13.02 Order of Work

Contractor shall provide City with a schedule of work, and Contractor shall perform all work in accordance therewith. Should circumstances cause Contractor to anticipate falling out of compliance with said schedule, Contractor shall notify City in advance and provide revised schedule for review and approval by the City.

13.03 Maintaining Traffic

Attention is directed to Sections 7-1.03, "Public Convenience," 7-1.04, "Public Safety," and Section 12, "Temporary Traffic Control," of the State Standard Specifications and these special provisions. Nothing in these special provisions shall be construed as relieving the Contractor from his responsibility as provided in said Section 7-1.04.

Lane closures shall conform to the provisions of Section 13.05, "Traffic Control System for Lane Closure" of these Improvement Standards.

The Contractor shall notify local authorities of his intent to begin work at least 5 days before work is begun. The Contractor shall cooperate with local authorities relative to handling traffic through the work area and shall make his own arrangements to keep the working area clear of parked vehicles.

Whenever construction vehicles or equipment are parked on the shoulder within 6 feet of a traffic lane, the shoulder area shall be closed with fluorescent traffic cones or portable delineators placed on a taper in advance of the parked vehicles or equipment and along the edge of the pavement at 25-foot intervals to a point not less than 25 feet past the last vehicle or piece of equipment. A minimum of 9 cones or portable delineators shall be used for the taper. A C23 (Road Work Ahead) or C24 (Shoulder Work Ahead) sign shall be mounted on a telescoping flag tree with flags. The flag tree shall be placed where directed by the Engineer.

Minor deviations from the requirements of this section concerning hours of work which do not significantly change the scope of the work may be permitted upon the written request of the Contractor if in the opinion of the City Engineer public traffic will be better served and the work expedited. Such deviations shall not be adopted until the City Engineer has indicated his written approval.

13.04 Construction Area Signs

Construction area signs shall be furnished, installed, maintained, and removed when no longer required in accordance with the provisions in Section 12, "Construction Area Traffic Control Devices," of the State Standard Specifications.

Type IV reflective sheeting for sign panels for portable construction area signs shall conform to the requirements specified as "Pre-qualified and Tested Signing and Delineation Materials" by Caltrans.

13.05 Traffic Control System for Lane Closure

A traffic control system shall consist of closing traffic lanes in accordance with the provisions of Section 12, "Construction Area Traffic Control Devices," of the State Standard Specifications and the provisions under "Maintaining Traffic" elsewhere in these Improvement Standards.

The provisions in this section will not relieve the Contractor from his responsibility to provide such additional devices or take such measures as may be necessary to comply with the provisions in Section 7-1.04, "Public Safety," of the State Standard Specifications.

If any component in the traffic control system is displaced, or ceases to operate or function as specified, from any cause, during the progress of the work, the Contractor shall immediately repair said component to its original condition or replace said component and shall restore the component to its original location.

When lane closures are made for work periods only, at the end of each work period, all components of the traffic control system, except portable delineators placed along open trenches or excavation adjacent to the traveled way, shall be removed from the traveled way and shoulder. When the Contractor so elects, said components may be stored at selected central locations approved by the Engineer, within the limits of the right of way.

Work areas adjacent to city streets shall be open to two-way traffic by 4:00 p.m. each work day. One lane shall remain open to traffic during construction unless otherwise approved by the City.

Contractor shall submit a Traffic Control Plan for review and approval by the City Engineer and Police Chief prior to commencing work affecting city streets.

13.06 Obstructions

Attention is directed to Section 15, "Existing Facilities," of the State Standard Specifications.

The Contractor shall notify the City and the appropriate regional notification center for operators of subsurface installations at least 2 working days, but not more than 14 calendar days, prior to performing any excavation or other work close to any underground pipeline, conduit, duct, wire or other structure. Regional notification centers include but are not limited to the following:

NOTIFICATION CENTER	TELEPHONE NUMBER
City of Sutter Creek	(209) 267-5647
Underground Service Alert Northern California (USA)	811

13.07 Adjust Utilities to Grade

Contractor shall adjust all valve boxes, manhole frames, and meter boxes to grade in accordance with the approved plans and these Improvement Standards. (See Section 18.00, Standard Details)

13.08 Clearing and Grubbing

Clearing and grubbing shall conform to the provisions in Section 17-2, "Clearing and Grubbing," of the State Standard Specifications.

Contractor shall protect existing trees from damage caused by his operations. All work in drip line of trees shall be as directed by City Engineer. Pervious backfill shall be placed around all root structures exposed by Contractor's operations. Attention is directed to Sutter Creek City Code Chapter 13.24, "Trees and Landscaping," and specific project conditions of approval.

13.09 Asphalt Concrete

Asphalt concrete and pavement reinforcing fabric shall conform to the provisions in Section 39, "Asphalt Concrete," of the State Standard Specifications and shall be 1/2" or 3/4" maximum, medium grade, Type B aggregate as directed by the City Engineer.

13.10 Pavement Reinforcing Fabric

Pavement reinforcing fabric shall conform to the provisions of Section 96, "Geosynthetics" of the State Standard Specifications. Reinforcing fabric shall be placed at location specified on the plans or in accordance with limits marked in the field.

13.11 Fog Seal Coat

Fog seal coat shall conform to the provisions in Section 37, "Bituminous Seals," of the State Standard Specifications. Fog seal shall be 60 percent asphalt emulsion and 40 percent water and shall be applied at the rate of 0.10 to 0.12 gallons per square yard. Contractor shall provide City Engineer verification of asphalt emulsion used.

13.12 Striping and Pavement Markings

Roadway striping shall conform to Section 84, "Markings," of the State Standard Specifications, Manual on Uniform Traffic Control Devices, the approved plans and these Improvement Standards.

13.13 Subsurface Drain

Contractor shall construct subsurface drain where required in accordance with Section 68, "Subsurface Drains," of the State Standard Specifications, the approved plans and these Improvement Standards.

13.14 Locate and Protect Existing Utilities

This item of work shall cover the location and protection of ALL existing underground utilities as required under Section 4215 of the Government Code as amended and Section 13.06, "Obstructions," of these Improvement Standards.

Contractor shall locate existing utilities and pothole designated areas for location and protection of existing underground facilities within the project limits prior to start of work and as necessary to coordinate and schedule his work.

14.00 CONSTRUCTION STANDARDS - STREET LIGHTING

General

Street lighting improvements associated with new development shall be constructed in conformance with Section 86, Signals, Lighting and Electrical Systems, of the State Standard Specifications and the requirements of the National Electric Code (NEC) except as modified by these improvement standards. The work shall consist of furnishing and installing luminaires with LED lamps, photoelectric cells; electrolier standards, electrolier arms and foundations, solar powered lights where feasible, conduit and conductor wiring and all other materials and appurtenances in accordance with the project plans and these standards.

14.01 Materials and Construction

All materials and construction shall be in compliance with this section of these Improvement Standards.

- A. All materials delivered to the job shall be new and best quality of their respective grades in accordance with the following specifications and packed in their original sealed containers. All materials to be installed shall bear the Underwriters Laboratories, Inc. (U.L.) label.
- B. The Contractor shall use materials mentioned in these Improvement Standards as standard, and in no case will a substitute be allowed without written approval of the City Engineer.
- C. All work and material shall be protected at all times. Conduit openings shall be closed with protective caps during installation and all materials shall be covered and protected against dirt, water, and mechanical or other injury. All materials damaged during course of construction shall be replaced or repaired to original condition by the Contractor prior to acceptance of work.
- D. The Contractor shall not allow or cause any of his work to be covered up or enclosed until it has been inspected and approved by the City Inspector. Should any of the work be enclosed or covered up before such inspection, the Contractor shall uncover the work at his own expense and after it has been inspected and approved make all repairs with such material as may be necessary to restore all work to its original and proper condition.
- E. The Contractor shall furnish and install the street lighting equipment in accordance with these Improvement Standards.

14.02 Foundations

Foundations shall be cast-in-place and in conformance with Section 86-2.01 "Excavating and Backfilling," and Section 86-2.03, "Foundations," of the State Standard Specifications except as amended herein and on the Standard Details.

14.03 Electrolier Standards

Electrolier standards shall be defined for the purpose of these Improvement Standards to include the pole, base, and base cover. Electrolier Standards shall conform to the Standard Details and the following requirements:

- A. Each standard shall have an identification Street Light number sticker as assigned by PG&E.
- B. The hand hole shall be oriented on the pole so that a technician facing oncoming traffic while facing the hand hole.
- C. All electrolier standards shall be furnished with a grounding lug or nut installed opposite the hand hole/removable access door and inside the standard.
- D. Electrolier standards shall conform to the Standard Details and the following criteria:
 - 1. The pole shall consist of galvanized steel material with a minimum thickness of 11 gauge.
 - 2. The poles shall be single-arm poles unless the Project Plans specify otherwise.

14.04 Electrolier Arm

Electrolier Arms shall conform to City Standard Details.

14.05 Conduit

Conduit shall be furnished and installed, conforming to the Standard Details, the requirements of Underwriters Laboratories Publication UL 543, and the following:

- A. Conduit shall be 1¹/₂" PVC, Schedule 40 conduit.
- B. Cutting and machining of conduit shall be in accordance with the manufacturer's recommendations. Pre-assembly of sections of conduit shall not be permitted except where jacking is required.
- C. Pulling bells shall be installed on the ends of conduit terminating in pull boxes and electrolier standards.
- D. The installation of conduit shall conform to the following:
 - 1. Excavation and Backfill for conduit installation shall conform to Section 15.04 " Trenches & Backfill," of the City Improvement Standards except as amended by this Section 14, "Street Lighting," of the City Improvement Standards and the Standard Details.

2. The conduit shall be laid over two inches of uniformly spread sand, and shall be covered by a minimum of 6 inches of sand.

14.06 Pull Boxes

Pull boxes shall conform to the provisions of Section 86-2.06, "Pull Boxes," of the State Standard Specifications as amended herein by this Section 14, "Street Lighting," of the City Improvement Standards and Standard Details.

- A. Pull boxes shall be precast reinforced concrete, Caltrans #3 1/2 Box with brass hold down bolts.
- B. The cover shall be marked "Street Lighting."
- C. Grout shall not be placed in the bottom of the pull box.

14.07 Conductors and Wiring

Conductors and wiring shall conform to the provisions of Section 86-2.08, "Conductors," and Section 86-2.09, "Wiring," of the State Standard Specifications as amended herein by this Section 14, "Street Lighting," of the City Improvement Standards and Standard Details.

- A. Conductors shall be AWG and THHN copper stranded conductor Underwriters Laboratory Approved.
- B. The size of the conductors shall be as designated on the Project Plans.
- C. Any NEC approved splice excluding wire nuts connections may be used for splice connections.
- D. Splices shall be insulated in accordance with Section 86-2.09E, "Splice Insulation," type "B" method of the State Standard Specifications.
- E. A fused disconnect splice connector shall be installed in each conductor between the line and ballast and shall be located and readily accessible within the hand hole of the electrolier standard. The fused disconnect splice shall consist of a Class CC (NEC) midget fuse holder with a 5 amp 250 volt non time delay midget fuse.

14.08 Luminaires

Luminaires shall conform to the Standard Details and the following requirements:

- A. Luminaires shall consist of a housing, a reflector, a photoelectric control, and integral regular type ballast unless otherwise approved by the City Engineer. Luminaires, complete with LED lamps, shall be installed in the proper orientation to produce the desired light pattern and shall be completely assembled and connected to the conductor. The operating voltage shall be 120 volts unless otherwise specified.

The following shall be provided for City approval:

1. Maximum power in watts.
2. Maximum designed junction temperature.
3. Heat sink area in square inches.
4. Designed junction-to-ambient thermal resistance calculation with thermal resistance components clearly defined.
5. L70 in hours when extrapolated for the average nighttime operating temperature.
6. Life expectancy based on the junction temperature.
7. Manufacturer's data sheet for the power supply, including the rated life.

Submit the manufacturer's QC test data for LED luminaires as an informational submittal.

14.09 Lamps

Unless otherwise specified, LED lamps shall be installed in the luminaires. The wattage of the lamps shall be specified on the Project Plans.

14.10 Photoelectric Control

Photoelectric control shall be multi voltage photoelectric relay on a twist lock receptacle. A photoelectric cell shall be installed on each street light located on the top of the luminaire fixture.

14.11 Service Connection (Non-Solar Powered Lights)

Service connections for street lights served by underground electrical systems will be made at the Service Point Location designated on the Project Plans which is normally a PG&E secondary box. Service Connections shall conform to the following requirements:

- A. The Contractor shall provide conduit and wire from the PG&E secondary box to and throughout the new street light system.
- B. Wires shall be tagged at secondary box in accordance with the latest and applicable PG&E detail.
- C. Service connections for electroliers served by the overhead electrical systems will be made at a junction box located at the base of the service riser pole. The Contractor shall provide the junction box, conduit and wire from the junction box to the pull box adjacent to the nearest street light.
- D. All service connections will be made by PG&E. The Contractor/Developer shall bear all costs by PG&E for service connection(s).

15.00 CONSTRUCTION STANDARDS - STORM DRAIN

15.01 Storm Drain Pipe

Storm drain pipe shall conform to the provisions in Section 64, "Plastic Pipe" of the State Standard Specifications. Storm drain pipe shall be SDR 35. All piping shall be backfilled in accordance with Section 15.04 of these Improvement Standards.

Backfill material shall conform to Section 18.00, Standard Details.

15.02 Installation

Pipe shall be laid in strict conformity with the prescribed alignment and grade specified in the plans and these Improvement Standards, or as directed by the City Engineer. Before any length of pipe is laid, it shall be carefully inspected for defects. No pipe or other material that shows defect shall be placed. Pipe laying shall proceed upgrade with the bell ends of the pipe placed upstream. Each section of pipe shall be laid in such a manner as to form a water tight concentric joint with the adjoining pipe. The interior of the pipe shall be kept clear of all dirt and debris during construction.

All pipe laying and joining, including the maximum deflection of joints in curved alignment shall be in accordance with the pipe manufacturer's specifications and as directed by the City Engineer.

Small diameter storm drain connections to 36" diameter storm drain shall be in accordance with 36" diameter pipe manufacturer's recommendations and shall be water tight. No protrusion into large diameter pipe will be allowed.

Deflection for PVC pipe after installation shall not exceed manufacturer's recommended maximum deflection at any location. Should the installed pipe exceed manufacturer's recommended maximum deflection, each and every length of pipe so affected shall be removed and replaced.

15.03 Trenches and Backfill

This work shall consist of performing all operations necessary to excavate earth and rock or other material, of whatever nature, including water, regardless of character and subsurface conditions, necessary to excavate trenches for pipes and appurtenances; to place backfill for structure, pipes and appurtenances and other facilities; to backfill trenches and depressions resulting from the removal of obstructions; to remove and replace unsuitable material; to construct protection dikes; and to remove unstable material and slide material which may enter trenches. All such work shall be in conformance with the approved plans and these Improvement Standards or as directed by the City Engineer. Typical trench details shall be shown on the plans.

Backfill material shall conform to the provisions in Section 19, "Earthwork," of the State Standard Specifications. Pervious backfill material required by the plans and these specifications shall be considered structure backfill and full compensation therefore shall be included in the contract price paid for the various items of work, and no additional compensation will be allowed therefore.

When a firm foundation is not encountered due to soft, spongy, or other unsuitable material, such material shall be removed to the limits directed by the Engineer, and the resulting excavation shall be backfilled with approved washed drain rock compacted to ninety-five percent (95%).

When removal of unsuitable material requires excavation to a depth greater than 12" below pipe flow line grade, the Engineer will determine the limits of the required excavation. Excavation limits shall be trench width for the length specified by the Engineer.

Where pipes are to be installed above original ground or in new embankment fills, embankment shall first be constructed to the required height for a distance on each side of the pipeline of not less than five feet (5'). Embankment shall have relative compaction of not less than ninety-five percent (95%). Upon completion and approval of the embankment the trench shall be excavated with the sides nearly vertical and the pipelines installed in accordance with these Improvement Standards.

Materials excavated from trenches shall be placed and maintained so as to offer minimum obstruction to traffic.

Unsuitable materials shall become the property of the Contractor and disposed of in accordance with local regulations.

Ditches shall be kept clear for the purpose of handling road drainage. Drainage ways, walkways, and driveways shall be kept clear.

At the end of each working day, there shall be no open trench, unless otherwise permitted by the City Engineer.

In connection with earthwork, all tests shall be made in conformance with the following requirements set forth in the State Standard Specifications:

<u>Tests</u>	<u>Test Method No</u>
Relative Compaction	Cal 216 & 231
Sand Equivalent	217
Resistance (R-value)	301
Sieve Analysis	202

Foreign material which falls into the trench prior to or during placement of the backfill shall be removed.

The trench widths set forth on the plans are minimum widths. Where excavation greater than the specified widths is necessary for execution of the work, machine or hand excavation to a stabilized slope will be permitted provided one-way traffic can be maintained. Minimum trench width is the distance face-to-face of trench walls or inside face to inside face of sheeting should solid sheeting be used. Maximum trench widths from the bottom of the trench to the top of the pipe shall be limited to six inches (6") outside the specified minimum trench width, except with specific approval by the City Engineer.

The Contractor shall furnish all materials and facilities required for trench excavation and shall make trenches and excavation dry throughout all pipe laying operations.

The location of underground utilities or other obstructions shall be determined by the Contractor sufficiently in advance of excavation so that pipe alignment can be confirmed or re-routed without delay. Contractor's attention is directed to Section 13.14, "Locate and Protect Existing Utilities," of these Improvement Standards.

Material for backfill shall be placed in uniform horizontal layers not exceeding one foot (1') in thickness before compaction, and shall be brought up uniformly on all sides of the trench, structure or facility. When the Contractor can satisfactorily demonstrate to the City Engineer an alternative method of placing the backfill so that all requirements, other than the layer thickness, are met, the City Engineer may permit the Contractor to use the alternative method. Under no circumstance will the Contractor use the alternative method unless the City Engineer's approval is obtained in writing.

Each layer of backfill shall be compacted to a relative compaction indicated for the backfill involved.

Backfill shall not be placed until the pipe or other facility has been inspected by the City Engineer and approved for backfilling. The percentage composition by weight as determined by laboratory sieves shall conform to the following requirements:

Class 1 Backfill

<u>Sieve Sizes</u>	<u>% Passing Sieves*</u>
No. 4	90-100
No. 200	<5

*Gradations requirements may be waived with written approval from the Engineer.

"Crusher fines" are acceptable for Class 1 backfill. "Pervious backfill" shall be coarse or medium screenings in accordance with Section 37, "Bituminous Seals," of the State Standard Specifications or as otherwise approved by Engineer.

Class 2 Backfill

Class 2 Aggregate Base, 3/4" maximum, in accordance with Sections 26-1.02, 26-1.02B, 26-1.03 of the State Standard Specifications except that percentage of No. 200 material shall be 15-30% unless otherwise approved by the Engineer.

Class 3 Backfill

Material for Class 3 Backfill may consist of material from excavation free from rocks or lumps exceeding three inches (3") in greatest dimension, vegetable matter, and other unsatisfactory material. Backfill shall be compacted to the relative compaction shown on the plans or as set forth in these specifications.

Class 4 Backfill

Class 4 Backfill shall be cement-sand slurry comprised of aggregate, cement and water. The aggregate, cement and water shall be proportioned either by weight or volume. Cement used shall be 190 to 210 pounds for each cubic yard of material produced. The water content shall be sufficient to produce a fluid workable mix that will flow and can be pumped without segregation of the aggregate while being placed.

Materials shall be thoroughly machine mixed in a rotary drum mix truck and placed in the trench from a direct truck discharge unless otherwise approved.

Mixing shall continue until cement and water are thoroughly dispersed throughout the material. All mixed slurry shall be placed within one hour of the introduction of water and cement to the material.

Aggregate shall be commercial-quality concrete sand. Aggregate shall be free of organic materials and other deleterious substances and have a minimum sand equivalent of 20. Aggregate shall conform to the following grading:

<u>Sieve Sizes</u>	<u>% Passing Sieves*</u>
1/2"	95-100%
3/8"	80-100%
#4	75-100%
#100	10-24%

The Contractor may use Class 4 backfill, slurry backfill, at locations approved by the Engineer as an alternative to Class 1 backfill. Slurry backfill shall be placed to neat line trench walls using

care to completely envelope the pipe in the backfill. Road surfacing will not be permitted until the Engineer is satisfied that the set is sufficient to support traffic but in no case prior to setting four (4) hours. The Contractor shall include in all items of work using slurry backfill the full cost of all labor and equipment to prevent traffic from crossing any trench with slurry backfill prior to setting.

The Contractor may use sufficient amounts of additives for speeding the set of slurry backfill in accordance with manufacturer's recommendations. No additive shall be used without prior approval of the Engineer as to type and amount.

Slurry backfill shall be placed in a uniform manner that prevents voids in, or segregation of the backfill and will not float the pipe.

15.04 Compaction Testing

The Owner will provide compaction tests at various locations during the work as directed by the Engineer. In the event of a test failure, the Contractor shall remove and re-compact unacceptable backfill or fills in accordance with the plans and specifications.

THE COST OF RE-TESTING SHALL BE BORNE BY THE OWNER OR CONTRACTOR.

15.05 Manholes

All manholes shall be of concrete construction and shall be placed in accordance with the approved plans, and these Improvement Standards. The manhole base may be pre-cast or poured in place, conform to ASTM C-470, and shall be placed in accordance with the plans and these specifications. Control of water in excavations shall be to the satisfaction of the City Engineer. Precautions shall be taken to assure that pipe entering and leaving manholes does not deviate from the installed alignment and grade during and after construction. Flex connectors at the inlet and outlet of manholes shall comply with ASTM C-923. Sufficient material shall be placed on said lines to prevent such movement. Ground beneath the manhole shall be compacted to 95% relative compaction prior to placing the base.

All manholes shall be precast concrete bases with precast reinforced concrete pipe sections, tapered sections, and adjustment rings. Reinforced concrete parts shall conform to ASTM designation C-478, and pipe sections shall be not less than 4 feet inside diameter.

Manhole joints shall be sealed against infiltration and exfiltration by means of sand-cement mortar between each joint, or by means of joint sealing compound as manufactured by the K.T. Schneider Co., Houston, Texas under the brand name "Ram-Nek," or "Quick-Seal," as manufactured by Associated Concrete Products, Inc., or approved equal. Appropriate primers and preparation as specified by manufacturer shall be used.

Manholes shall be finished inside and out with sand-cement mortar to produce a water tight, smooth finish. Flow line channel through manhole shall have smooth trowel finish.

Backfill shall be placed uniformly around the outside of the manhole so as to not create differential forces and the possibility of dislodging the manhole sections.

15.06 Concrete Structures

Concrete structures (drainage inlets and junction boxes, headwalls, inlet and outlet structures) shall be constructed of Class A concrete and shall conform to the plans, the provisions in Section 51, "Concrete Structures," of the State Standard Specifications, and these Improvement Standards. Concrete structure reinforcement, when not set forth on plans, shall conform to Caltrans Standard Plan details.

Box culvert invert elevations shall be as directed by the City Engineer to match existing conditions.

All concrete structures shall have smooth trowel finish and rounded inlets at all openings. Drainage inlet, junction box combination structures shall pass full pipe flow in concrete channel.

Concrete structures in roadways shall be backfilled with Class 2 backfill compacted to not less than ninety-five percent (95%) relative compaction. Concrete structures off road or behind concrete curbs shall be backfilled with Class 3 backfill at not less than ninety percent (90%) relative compaction.

15.07 Miscellaneous Iron and Steel

Frames, grates, covers, and manhole riser rings shall conform to the provisions in Section 75, "Miscellaneous Metal," of the State Standard Specifications.

Manhole frames and covers shall be cast iron in accordance with ASTM A-48, Class 35B with H20 loading rating and shall be California Concrete Pipe Model A-640/A-1024 or approved equal.

Manhole covers shall have raised lettering not less than 1" spelling out "City of Sutter Creek," cast into cover and center of each manhole shall spell out "Sewer" or "Storm Drain" with 2" lettering or as approved by City Engineer.

15.10 Adjusting Utilities to Grade

Contractor shall adjust existing manhole frames, water valve boxes, and water meter boxes affected by his work to grade in accordance with these Improvement Standards.

Manholes shall be adjusted to grade with cast iron riser rings and asphalt concrete backfill. Riser rings shall conform to these Improvement Standards. Asphalt concrete shall conform with Section 13.09 except it can be hand placed.

16.00 CONSTRUCTION STANDARDS – SANITARY SEWER

TITLE	PAGE
SECTION 01080 – STANDARD SPECIFICATIONS	01080/1
SECTION 01210 – PRECONSTRUCTION CONFERENCE	01210/1
SECTION 01220 – PROGRESS MEETING	01220/1
SECTION 01300 – SUBMITTALS	01300/1
SECTION 01380 – PRECONSTRUCTION PHOTOGRAPHS	01380/1
SECTION 01500 – TEMPORARY FACILITIES	01500/1 – 01500/2
SECTION 01560 – SPECIAL CONTROLS	01560/1 – 01560/3
SECTION 01700 – CONTRACT CLOSEOUT	01700/1 – 01700/2
SECTION 02102 – CLEARING AND GRUBBING	02102/1
SECTION 02200 – EARTHWORK	02200/1
SECTION 02221 – EXCAVATION, TRENCHING AND BACKFILLING	02221/1 – 02221/4
SECTION 02540 – EROSION CONTROL	02540/1 – 02540/3
SECTION 02701 – ROADWAY REPAIR	02701/1 – 02701/2
SECTION 03306 – CONCRETE	03306/1 – 03306/3
SECTION 15060 – PIPE AND PIPE FITTINGS	15060/1
SECTION 15403 – GRAVITY SEWERS	15403/1 – 15403/6
STANDARD PRACTICE FOR TESTING CONCRETE SEWER MANHOLES BY THE NEGATIVE AIR PRESSURE (VACUUM) TEST	ATTACHMENT A
STANDARD DETAILS	ATTACHMENT B

SECTION 01080 - STANDARD SPECIFICATIONS

All items noted on the plans related to the installation of sewers not covered by these Technical Specifications shall be provided and installed per the Standard Specifications.

The Standard Specifications shall be as published by the State of California, Business and Transportation Agency, Department of Transportation, latest edition.

Whenever in the Standard Specifications the following terms are used, the intent and meaning shall be interpreted as follows:

1. Department of Transportation: City of Sutter Creek
2. Engineer of State Highway Engineer: Weatherby-Reynolds-Fritson Engineering and Design.
3. State: City of Sutter Creek
4. Special Provisions: These specifications and contract documents.

In case of conflict between the Standard Specifications and these Technical Specifications, these Technical Specifications shall take precedence over and be used in lieu of such conflicting portions.

SECTION 01210 - PRECONSTRUCTION CONFERENCE

DESCRIPTION: Prior to start of construction, owner will arrange an on-site meeting with the contractor. The meeting agenda will include the following:

- Correspondence Procedures
- Designation of Responsible Personnel
- Labor Standards Provisions
- Payroll Reports
- Changes
- Payments to Contractor
- Subcontractors
- County and State Regulations
- Accident Prevention Program (including name of responsible supervisor)
- Safety Program
- Tentative Construction Schedule
- Submittal of Shop Drawings, Project Data and Samples

The contractor shall designate a supervisory employee to carry out the Contractor's Accident Prevention Program and shall submit a proposed Safety Program, for approval by the owner, prior to commencing work under the contract.

SECTION 01220 - PROGRESS MEETINGS

Once each month, the contractor and engineer shall arrange for an on-site meeting to discuss the following agenda items:

1. Review past months progress and update progress schedule submitted (Section 01300).
2. Determine and review next months' progress.
3. Update record drawings.
4. Determine contract payment amount.
5. Review change order progress.
6. Determine need for additional change orders.
7. Review payroll records.
8. Submission of shop drawings, project data and samples.
9. Other items, as necessary.

The contractor shall be responsible for maintaining one complete set of plans and specifications at the job site for the progress meeting and shall be turned over to the engineer before final payment request.

Upon completion of all work and prior to final contract payment, the contractor shall furnish the engineer with three (3) sets of prints, catalog cuts, parts lists and operations and maintenance manuals for all mechanical and electrical items incorporated in the work.

SECTION 01300 - SUBMITTALS

1. **SUBMISSION PROCEDURES:** At least ten (10) days before contractor's need for approval, submit three copies or two specimens (unless a different number is specified in the individual section) of all submittals required under this section to engineer. Identify all submittals. When approved, one copy will be returned to contractor. However, engineer reserves the right to request additional submittals. No materials requiring engineer's approval shall be delivered to the site until approval has been given.
2. **ENGINEER'S APPROVAL:** Engineer will indicate his approval or disapproval of the submittals and, if not approved as submitted, will indicate his reasons therefor. Any work done prior to such approval shall be at contractor's risk.
3. **SHOP DRAWINGS:**
 - A. **Definition:** The term "shop drawings" includes drawings, diagrams, layouts, schematics, descriptive literature, illustrations, schedules, performance and test data, and similar materials furnished by contractor to explain in detail specific portions of the work required by the contract.
 - B. **Contractor's Review and Approval:** Contractor shall coordinate all such drawings, and review them for legibility, accuracy, completeness and compliance with contract requirements and shall indicate his approval thereon as evidence of such coordination and review. Shop drawings submitted to engineer without evidence of contractor's approval shall be returned for resubmission.
 - C. **Approval by Engineer:** Such approval shall not relieve contractor from responsibility for any errors or omissions in such drawings, nor from responsibility for complying with the requirements of this contract, except with respect to variations described and approved in accordance with Paragraph D below.
 - D. **If shop drawings show variations from the contract requirements, contractor shall describe such variations in writing, separate from the drawings, at the time of submission. All such variations must be approved by the engineer.**
4. **PROGRESS SCHEDULE:** Within five (5) days after receiving Notice to Proceed, submit a Progress Schedule (normally in bar chart form) showing estimated starting and completion dates for each part of the work.

SECTION 01380 - PRECONSTRUCTION PHOTOGRAPHS

Prior to starting construction, contractor shall provide engineer with preconstruction photographs as follows:

Pipeline:

- a) Public streets - 100 ft. intervals looking ahead.
- b) Cross-Country - 200 ft. intervals looking ahead.
- c) Fence Lines and Driveways - Two (2) required at each crossing to clearly show condition and materials of construction.
- d) Minor Structures - Four (4) required, one (1) from each of the cardinal directions, such as: North, South, East and West; or, in the case of stream structures, upstream and downstream; and one (1) from each side of the stream.

Buildings and Major Structures:

At least ten (10) photographs from angles sufficient to show all aspects of the construction.

Photographs will be processed; identified for location and placed in a photo album; bound in hard-back, three ring (two-inch diameter) binders; and turned over to the owner within thirty (30) days after award of contract and prior to starting construction.

NO WORK SHALL BE ALLOWED TO START UNTIL PHOTO ALBUM HAS BEEN REVIEWED AND APPROVED BY THE ENGINEER.

SECTION 01500 - TEMPORARY FACILITIES

1. **SIGNS, SIGNALS, AND BARRICADES:** Contractor to provide, erect and maintain barricades, lights, danger signals and warning signs, and take all necessary precautions for the protection of the work.
2. **UTILITIES:**
 - A. **Power:** The contractor shall arrange with the Pacific Gas and Electric Company for temporary and permanent electric power used for construction and operation. The cost of construction power shall be paid by the contractor. **EXISTING UTILITY POLES ARE NOT TO BE MOVED.**
 - B. **Water:** Water for all domestic consumption and construction will be provided by the contractor. Contact the Amador County Water Agency at 223-3018.
 - C. **Temporary Heating:** The contractor shall provide temporary heating, covering and portable enclosures as necessary to protect all work and material against damage by dampness and cold. The contractor shall supply all fuel, equipment and materials required for temporary heating.
3. **STORAGE FACILITIES:**
 - A. Confine storage of materials to contractor's office site.
 - B. Contractor to provide temporary sheds or other covered facilities for storage of materials subject to weather damage. Number and size of structures shall be subject to engineer's approval. Locate structures to avoid interference with work and relocate as required by progress of work.
 - C. Contractor to remove structures and surplus stored materials at completion of work.
4. **SANITARY FACILITIES:**
 - A. Contractor to provide and maintain facilities in compliance with applicable state and local laws, codes and ordinances.
 - B. Contractor to provide cool, potable water for construction personnel in locations convenient to work stations.
 - C. Contractor to provide sufficient lighted and ventilated toilet facilities in weatherproof, sightproof, sturdy enclosures. Place in approved locations where facilities will be secluded from public observation and convenient to work stations. Relocate as work progress requires.
 - D. Contractor to completely remove temporary facilities on completion of work.
5. **CONSTRUCTION CAMP:** No construction camp will be allowed on the project site.

6. **CONTRACTOR'S OFFICE:** During the performance of the contract, the contractor may maintain a suitable office at the site of the work which shall be the headquarters of a representative of the contractor. If the contractor elects to provide office space, it shall be a subsidiary obligation of all other items of work.

SECTION 01560 - SPECIAL CONTROLS

1. **PRESERVATION OF NATURAL FEATURES:** Confine all operations to within the work limits of the project. Exercise special care to maintain natural surroundings undamaged. Do not remove, injure or destroy trees or other planting without prior approval. Do not fasten ropes, cables or guys to existing trees for anchorage. Restore damaged trees or natural features as nearly as possible to original condition at no additional expense to the owner.
2. **HOUSEKEEPING:**
 - A. Keep project neat, orderly and in a safe condition at all times. Immediately remove all hazardous rubbish. Do not allow rubbish to accumulate. Provide on-site containers for collection of rubbish or dispose of it at weekly intervals during progress of work.
 - B. Wet down dry materials and rubbish to prevent blowing dust.
 - C. Keep volatile waste in covered containers.
 - D. Unless stated otherwise in permits, place cold mix surfacing where trench crosses areas where permanent paving is required at the end of each day's work.
3. **DISPOSAL OF RUBBISH:** Dispose of waste materials, legally, at county dump. Do not bury wastes inside the project site.
4. **AIR AND WATER POLLUTION CONTROL:**
 - A. Take all necessary reasonable measures to reduce air and water pollution by any material or equipment used during construction.
 - B. No burning of debris will be permitted inside the project unless a valid California Division of Forestry burning permit has been issued.
 - C. Do not dispose of volatile wastes or oils in storm or sanitary drains, nor allow such materials to reach streams.
 - D. Do not allow waste materials to be washed into the bed of a stream. Provide silt fences and hay bales, as required.
 - E. When excavations are made, immediately utilize resultant loose earth by filling and compacting in place, or dispose of it off the site.
5. **FIRE PREVENTION AND PROTECTION:**
 - A. **Hazard Control:** Take all necessary precautions to prevent fire during construction. Provide adequate ventilation during use of volatile or noxious substances.
 - B. **Spark Arrestors:** Equip all gasoline or diesel powered equipment used in potential forest or grass fire locations with spark arrestors approved by the U.S. Forest Service. Written determinations of areas and periods of potential fire hazard will be issued by engineer.

- C. Building Safety: Smoking within buildings or temporary storage sheds is prohibited. No welding or cutting by torch shall be performed unless adequate fire protection is provided and maintained for the duration of the work in the area of operations.
 - D. Protection Equipment Required: Provide and maintain suitable fire protection equipment. Furnish a minimum of one UL Class 2A, 2.5 gallon water type, stored pressure extinguisher, and one UL Class 10, Type 1, 15 pound B:C carbon dioxide extinguisher for each 3,000 square feet of building area or major fraction thereof. Travel distance from any workstation to the nearest extinguisher shall not exceed 100 feet.
6. DUST CONTROL: The contractor shall be responsible for alleviation or prevention of any dust nuisance arising from the work on this project, but the use of water or dust palliative as required, and as directed by the Engineer, and as set forth in these specifications. No separate payment will be made for dust control. The cost for same shall be considered to be included in the unit bid prices for the items to which it may apply. No petroleum or asphalt dust palliative may be used.
 7. OCCUPATIONAL SAFETY AND HEALTH REGULATIONS: All provisions of the California Occupational Safety and Health Act (OSHA) shall be adhered to.
 8. TRENCH SAFETY PLAN: The contractor shall be responsible for meeting all requirements of the State Division of Industrial Safety for trench excavations. Prior to the starting of work, the contractor shall obtain, at his expense, any necessary permits.

Nothing herein shall be deemed to allow the use of shoring, sloping or protective system less effective than that required by the Construction Safety Orders of the Division of Industrial Safety. In particular, the contractor shall, within five (5) days of the Notice to Proceed and in advance of excavation of any trench or trenches five feet or more in depth, submit to the owner a detailed plan showing the design of shoring, bracing, sloping or other provisions to be made for worker protection from the hazard of caving ground during the excavation of trench or trenches, in accordance with Section 6705 of the Labor Code, for acceptance by the engineer, and shall not proceed with such trenching until the plan has been accepted by the engineer. If such plan varies from the shoring system standards established by the Construction Safety Orders, the plan shall be prepared by a registered civil or structural engineer. Attention is directed to Section 832 of the Civil Code of the State of California relating to lateral and subjacent support, and the contractor shall comply with this law.

9. RIGHT OF ACCESS: The right is reserved to the owner, their consultants, employees or authorized agents, and electric, telephone and telegraph companies, and other utility companies to enter upon the area for the purpose of making repairs, changes and new installations that have become necessary by the improvement thereof, or for necessary maintenance or for construction review.
10. UTILITIES: Prior to starting construction, call U.S.A. (800) 227-2600 for assistance in locating all existing underground utilities.

SECTION 01700 - CONTRACT CLOSEOUT

1. FINAL CLEANING: Remove all tools, equipment, surplus materials, and rubbish. Repair marred surfaces and remove grease, dirt, stains, foreign materials, fingerprints, and labels from interior and exterior finished surfaces. Do any required waxing and polishing. At time of final inspection, project shall be thoroughly clean and ready for occupancy.
2. PROJECT RECORD DRAWINGS:
 - A. Using colored ink, make changes on a set of clean prints of original tracings. Indicate all changes and revisions to the original design, which affect the permanent structures and will exist in the completed work. Reference underground utilities to semi-permanent or permanent physical objects.
 - B. Keep record drawings current. Inspection will be made monthly. Certification of accuracy and completeness will be required on submitted monthly payment requisitions.
3. SUBSTANTIAL COMPLETION AND FINAL INSPECTION: Submit written certification that project, or designated portion of project, is substantially complete, and request, in writing, a final inspection within ten days of receipt of request.

Should owner determine that the work is substantially complete, he will prepare a punch list of deficiencies that need to be corrected before final acceptance, and issue a notice of substantial completion with the deficiencies noted. Should owner determine that the work is not substantially complete, he will immediately notify contractor, in writing, stating reasons. After contractor completes work, he shall resubmit certification and request for final inspection.

4. ACCEPTANCE OF THE WORK: After all deficiencies have been corrected, a letter of final acceptance will be issued. If only designated portions of the project have been inspected, a letter of partial acceptance will be issued for that portion of the work.

Temporary use of facilities by the owner will not constitute acceptance of the facilities used.

5. CLOSEOUT SUBMITTALS: Submit before final payment request.
 - A. Project Record Drawings: As specified above.
6. POST-CONSTRUCTION INSPECTION: Prior to expiration of one year from date of final acceptance, owner will inspect project to determine whether corrective work is required. Contractor will be notified, in writing, of all deficiencies. In accordance with terms of the Performance Bond, corrective work must start on noted deficiencies within ten days of receipt of notification to contractor or bonding company will be notified of forfeiture.

SECTION 02102 - CLEARING AND GRUBBING

PART 1: GENERAL

- 1-1 DESCRIPTION: The work of this section consists of the clearing of vegetation; removal of foundations, culverts, stumps, roots and debris; disposal of unutilized materials; and related incidentals required to prepare the site for the contract work.
- 1-2 JOB CONDITIONS: Work Limits: Specific areas to be cleared and grubbed will be the areas necessary to do the contract work. However, in no case shall the area to be cleared extend beyond twenty feet from the centerline of the pipe work or twenty feet from any structure, unless shown otherwise on the plans.

PART 2: MATERIALS – None.

PART 3: EXECUTION

- 3-1 GRUBBING: When the height of the embankment is less than three feet from finish subgrade, removal all stumps, roots, and debris a minimum of twelve inches below the original ground. When the height of the embankment is three feet or more from finish subgrade, stumps may be cut flush and left in place. In embankment areas, backfill stump and root holes with approved material and compact before placing embankment material. In all excavation areas, remove stumps, roots, and debris a minimum of twelve inches below finish grade. All excess material shall be hauled to the County solid waste disposal site, unless an alternative is presented to the engineer and approved prior to the need for disposal.

PART 4: MEASUREMENT AND PAYMENT

- 4-1 Per project agreement.

SECTION 02200 - EARTHWORK

PART 1: GENERAL

- 1-1 DESCRIPTION: Earthwork includes all labor, equipment, appliances, and materials as required or necessary to excavate, fill, backfill, and grade for the construction of all structures, ditches, dikes, embankments and graded areas, as shown on the plans and specified herein.

PART 2: MATERIALS

- 2-1 All materials for fill shall be native materials from the site unless all materials are found to be unusable. Material specifications shall be as noted in the Standard Specifications Section 19 and the California Building Code Appendix J, Latest Edition.

PART 3: EXECUTION

- 3-1 Earthwork shall conform to the provisions in section 19, "Earthwork", of the Standard Specifications, Appendix J of the California Building Code, Latest Edition, and these Special Provisions.

Compaction and placement dimensions shall meet the requirements of Section 19-6 (95% relative compaction) and the plans.

- 3-2 SURPLUS MATERIALS: All surplus materials may be stored at locations designated by the City of Sutter Creek Department of Public Works.

PART 4: MEASUREMENT AND PAYMENT

Measurement and payment shall conform to the provisions in Section 19-2 of the Standard Specifications (end-area method and cubic yards).

SECTION 02221 - EXCAVATION, TRENCHING AND BACKFILLING

PART 1: GENERAL

- 1-1 DESCRIPTION: The work of this section consists of excavating, trenching, and backfilling for the construction and installation of pipelines and related structures. All excavation will be open cut. It includes all clearing and grubbing, drilling and blasting, construction of cribbing and cofferdams, dewatering and incidental work.
- 1-2 RELATED WORK SPECIFIED ELSEWHERE: Watering, Section 02233.
- 1-3 JOB CONDITIONS: If unauthorized overexcavation occurs, contractor shall be responsible for the repair of the area by backfilling with approved select material and compacting to 95 percent maximum density. (AASHO-T-191)
- 1-4 EXCAVATION CLASSIFICATION: Regardless of the nature of material excavated, all excavation will be considered unclassified.

PART 2: MATERIALS

- 2-1 GENERAL: All backfill material shall be approved before use and be free of roots, brush, debris, or other objectionable material.
- 2-2 EXCAVATED MATERIALS: Use only approved material for backfill and provide additional needs from approved sources outside of the project boundaries. Excess excavated material for backfill may be transported and used in areas of deficiency.
- 2-3 BACKFILL MATERIAL:
 - A. Initial Backfill: Shall be the material placed around the pipe to a point six inches below the top of the pipe and may be selected from job excavated material provided such material is finely divided and free from debris, organic matter and other deleterious substances and shall be classified such that 100 percent passes the No. 3/4 inch sieve. The material shall be placed immediately after pipe joints have been completed, inspected and passed by the Engineer. The material shall be carefully placed so as not to disturb or damage the pipe and shall be brought up evenly on both sides.

Where imported bedding material is used, initial backfill material may be selected from job excavated material, as described previously, if such suitable material is available.
 - B. Intermediate Backfill: Trench backfill above the initial backfill and to a point two feet below the top of the trench may be of job excavated material or imported backfill material, placed in any manner determined by the contractor. However, until the total backfill above the top of the pipe exceeds one (1) foot, machine-placed backfill material shall not be allowed to "free-fall" more than two feet. Jetting will not be allowed.

- C. Trench Excavated Intermediate Backfill Material: Shall be free from organic matter and other deleterious material and shall contain no concrete, stones or clods larger than three (3) inches in diameter and shall contain sufficient fines so that all voids will be filled when compacted, and shall be so constituted that compaction requirements can be met.
- D. Imported Intermediate Backfill Material: Shall be identical with imported bedding material specified previously and shall be used where shown on the drawings. Jetting will not be allowed.
- E. Top Backfill: The top two feet of backfill shall be job excavated material free from organic matter and other deleterious material and shall contain no concrete, stones, clods larger than three (3) inches in diameter and shall contain sufficient fines so that all voids will be filled when compacted, and shall be so constituted that compaction requirements can be met.

3-1 WATER: Clean, free from harmful substances.

PART 3: EXECUTION

3-1 STRUCTURE EXCAVATION:

- A. Excavation Dimensions: Provide eighteen inches of clear working space, except as noted on the plans, between the exterior lines of the structure and the face of excavation or shoring. In all cases, extend to solid bearing and below frost line.
- B. Foundation Treatment: Clean all rock or other foundation surface of loose material and cut to a firm surface either level, stepped, or serrated, as directed. Avoid excavation below the specified grade.
- C. Excavation Approval: When excavation has been completed for a structure, the contractor shall notify the engineer, who will inspect the excavation. Place no concrete until the excavation is approved.

3-2 TRENCH EXCAVATION:

- A. General: Excavate trenches to lines, grades and elevations indicated or staked in the field. Fine grade the trench bottom throughout and excavate to accommodate joints and connections so the barrel of the pipe will receive bearing pressure throughout from the trench bottom.
- B. Trenching Guidelines: For excavation, trench width and depth shall be as follows: Width, ample to allow a minimum free working space of one foot on each side of pipe barrel, except when hand dug; width of hand excavated trenches may be reduced providing approval is given, stability of soil is consistent with depth of trench required, and pipe can be satisfactorily installed to line and grade and properly backfilled; depth, at least four inches, but not exceeding twelve inches below pipe bottom; hand excavate placements for thrust blocks at grade and trim sides straight upward to original ground; pump off water which has accumulated in low ground; and keep excavation drained of water.

- C. If water is allowed to stand and the earth is softened, the earth must be completely dried or removed to firm material and the proper backfill placed before construction can proceed.

3-3 SHORING AND SHEETING:

- A. Construct and maintain all shoring and sheeting necessary to protect the excavation, as needed for the safety of the employees and as required by applicable state and federal laws.
- B. Do not disturb or remove timber or other sheeting driven to a depth below the elevation of the top of the pipe.
- C. As directed, remove all other sheeting and shoring when safe to do so. Any portion wholly buried by earth and at a distance of at least eighteen inches from any timber members of permanent structures need not be stripped.
- D. When shoring or sheeting is used in the trench, the fill shall be carried to a height sufficient to prevent the surrounding ground from cracking or caving into the trench before the shoring or sheeting is removed.

3-4 BACKFILL: As directed, mound at the surface to allow for settlement to adjacent finish grades. Prior to final inspection and acceptance, level areas of fill to surrounding ground surface. Do not backfill until all pipelines have been inspected and tested, and permission given to backfill. Place no backfill against foundation walls until concrete has thoroughly set.

- A. Compaction of Backfill Material: May be accomplished by mechanical tamper, by vibrating, or by a combination of these methods, as required.

3-5 BACKFILL OF STRUCTURES: Place backfill material in horizontal uniform layers not to exceed eight inches. Bring each layer up uniformly on all sides of the structure and thoroughly compact using pneumatic compaction or other approved methods. Moisten backfill prior to placing to insure maximum compaction. Puddling or water flooding for consolidation of the backfill will not be permitted.

3-6 TRENCH BACKFILL WITHIN CITY ROADS: Trench backfill within City roads shall be concrete slurry per City Standard Detail.

3-7 TRENCH WORK WITHIN STATE RIGHT OF WAY: Same as above or per City permit.

3-8 TRENCH WORK WITHIN PRIVATE ROADWAYS, DRIVEWAYS AND/OR IN OTHER TRAFFIC AREAS: None.

3-9 TRENCH WORK WITHIN NON-TRAFFIC EASEMENTS LOCATIONS: Bedding and initial backfill portions of the trench shall be compacted to a minimum compactive effort of 90%, as measured by California Test Method No. 216. The intermediate portion of backfill shall be compacted sufficiently to prevent settling of the trench backfill.

- 3-10 SHORING, SHEETING AND BRACING: When shoring or sheeting is used in the trench, the fill shall be carried to a height sufficient to prevent the surrounding ground from cracking or caving into the trench before the shoring or sheeting is removed.
- 3-11 CHECK DAMS: Check dams shall be constructed to reduce erosion along the surface of the new trench construction.
- 3-12 CLEANUP: Grade all areas disturbed to a finish ordinarily obtained from a blade grader with no abrupt changes in grade or irregularities that will hold water. Prior to final inspection and acceptance, remove all rubbish and excess material and leave area in a neat, satisfactory condition.

PART 4: MEASUREMENT AND PAYMENT

- 4-1 Per project agreement.

SECTION 02540 - EROSION CONTROL

PART 1: GENERAL

- 1-1 DESCRIPTION: This work shall consist of performing, erosion control, planting and other work necessary for improving the appearance of the disturbed areas and preserving the owner's investment.

Erosion control and planting shall be performed in accordance with these technical specifications, the Cal-Trans Standard Specifications, Section 21 (Latest Edition), the details shown on the plans, and as directed by the engineer.

PART 2: MATERIALS

- 2-1 TOPSOIL: Shall consist of fertile, friable soil of loamy character and shall contain an amount of organic matter normal to the region. It shall be obtained from well drained arable land and shall be reasonably free from subsoil, refuse, roots, heavy or stiff clay, stones larger than one inch in size, coarse sand, noxious seeds, sticks, brush, litter and other deleterious substances. Topsoil shall be capable of sustaining healthy plant life.
- 2-2 COMMERCIAL FERTILIZER: Shall conform to the requirements of the California Food and Agricultural Code. Commercial fertilizer for erosion control work shall be in pelleted or granular form and shall have a minimum guaranteed chemical analysis of sixteen percent (16%) nitrogen and twenty percent (20%) phosphoric acid. The fertilizer for erosion control work need not contain water-soluble potash.
- 2-3 FIBER: Unless otherwise specified, fiber shall be produced from non-recycled wood, such as wood chips or similar wood materials and shall not be produced from sawdust or from paper, cardboard, or other such materials. Fiber shall be of such character that the fiber will disperse into a uniform slurry when mixed with water. Water content of the fiber, before mixing into a slurry, shall not exceed fifteen percent (15%) of the dry weight of the fiber. The percentage of water in the fiber shall be determined by California Test 226. Commercially packaged fiber shall have the moisture content of the fiber marked on the package. Fiber shall be colored to contrast with the area on which the fiber is to be applied, shall be non-toxic to plant or animal life, and shall not stain concrete or painted surfaces.
- 2-4 SEED: All seed that is required to be labeled under the California Food and Agricultural Code, shall be labeled in accordance with said Code.

Before seeding, the contractor shall furnish written evidence (seed label or letter) to the engineer that seed, not required to be labeled under the California Food and Agricultural Code, conforms to the purity and germination requirements in the special provisions.

The percentage of seed germination shall include the germination percentage of any hard seed.

If seed conforming to the specified purity or germination is not readily available, seed with less than the specified purity or germination may be used under the following conditions:

- A. The application rate for such seed shall be increased to compensate for the less than specified purity or germination.
- B. Prior to using such seed, the contractor shall submit to the engineer the purity and germination percentages, and the proposed increased application rate for such seed.
- C. No such seed shall be used before the engineer has approved, in writing, the use of such seed and the increased application rate.
- D. The additional seed required because of the increased application rate shall be furnished and applied at the contractor's expense.

Seed specified without a purity or germination requirement shall be labeled to include the name, date (month and year) collected, and the name and address of the seed supplier. Said seed, at the time of sowing, shall be from the previous or current year's harvest.

All shipments of seed not accompanied by a valid California Nursery Stock Certificate shall be reported to the County Agricultural Commissioner at the point of destination for inspection and shall be held until released by the Commissioner.

Seed treated with mercury compounds shall not be used.

- 2-5 SEED SPECIES: The seed used for all outside of yard areas shall consist of 50% Blando Brome and 50% Annual Rye. Contractor to contact the Amador County Agricultural Commissioner for verification of seed mixture. Seed for yard areas shall be an approved lawn seed selected by the contractor and approved by the engineer.
- 2-6 Twelve (12) straw hay bales shall be kept on the site at all times when rainfall and runoff are eminent. Steel rods (three feet long) shall be used (two per bale) to hold bales down.

PART 3: EXECUTION

- 3-1 DESCRIPTION: This work shall consist of furnishing erosion Control materials; preparing slopes and planting areas; placing topsoil where necessary; applying fertilizer, seed, fiber; and planting all areas disturbed by construction. Erosion control work shall consist of mixing seed, fertilizer, fiber and water and applying said mixture by hand or with hydro-seeding equipment, at the contractor's option.
- 3-2 PREPARATION: Preparation shall include all work required to make ready the areas for erosion control materials.

Loose rocks larger than 2.5 inches in maximum dimension and debris on the surface of the ground shall be removed and disposed of outside the project.

- 3-3 SEEDING AND FERTILIZING: Hand-seeding or hydro-seeding shall consist of mixing and applying seed and commercial fertilizer with fiber and water.

The materials shall be applied uniformly at the following rates:

- Seed: 100 pounds per acre
- Fertilizer: 100 pounds per acre
- Fiber: 500 pounds per acre

The quantity of water shall be as need for application.

Mixing of materials with hydro-seeding equipment shall be performed in a tank with a built-in continuous agitation system of sufficient operating capacity to produce a homogeneous mixture and a discharge system which will apply the mixture at a continuous and uniform rate.

- 3-4 PLACING STRAW BALES: Three (3) bales shall be placed at locations identified by the engineer if runoff occurs.

PART 4: MEASUREMENT AND PAYMENT

- 4-1 Per project agreement.

SECTION 02701 - ROADWAY REPAIR

PART 1: GENERAL

- 1-1 DESCRIPTION: The work of this section consists of the backfilling, compaction, grading and repaving of roadways damaged or destroyed during the construction of project elements and appurtenances.
- 1-2 RELATED WORK SPECIFIED ELSEWHERE: Section 02221 - Excavation, Trenching and Backfilling; Section 02233 - Watering; Encroachment Permits.
- 1-3 QUALITY ASSURANCE: California Business and Transportation Agency, Department of Transportation (Cal-Trans) Standard Specifications. Reference to Cal-Trans is for the purposes of specifying material requirements and methods only.

PART 2: MATERIALS

- 2-1 BACKFILL UNDER ROADWAYS: Shall be selected material approved by the Engineer and shall be free of humus, organic material and deleterious material.
- 2-2 AGGREGATE BASE COURSE: Shall comply with Standard Specifications Section 26-1.02B, Class 2 Aggregate Base and shall be 3/4 inch maximum.
- 2-3 PRIME COAT: Shall conform to Standard Specifications Section 93, Liquid Asphalts and shall be grade MC-70.
- 2-4 ASPHALTIC PAVEMENT: Shall conform to Standard Specifications Section 39, Asphaltic Concrete and shall be Type B, gradation .75 inch maximum medium. Asphalt shall be grade AR 4000. An equivalent cold mix shall be used for temporary paving.

PART 3: EXECUTION

- 3-1 BACKFILL: Shall be placed in accordance with Section 02221. The uppermost two feet of backfill shall be compacted to ninety-five percent (95%) of optimum density at optimum moisture content as measured in the field using AASHTO T-191, or as specified in the applicable Encroachment Permit.
- 3-2 AGGREGATE BASE: Shall be in accordance with Standard Specifications Section 26. Minimum depth shall be six inches for roadways.
- 3-3 PRIME COAT: Shall be in accordance with Standard Specifications Section 93 and shall be applied at the rate of .50 gallons per square yard, as directed for roadways.
- 3-4 ASPHALTIC PAVEMENT: All disturbed areas which were originally paved shall be repaved with minimum of two inches of asphalt concrete pavement for roadways. Asphalt concrete shall be in accordance with Standard Specifications Section 39. Finished pavement shall be spread and compacted in accordance with Standard Specifications Section 39-6 and 39-7.

At end of each day's work, temporary paving shall be placed in all areas where permanent paving will be placed.

PART 4: MEASUREMENT AND PAYMENT

4-1 Per project agreement.

SECTION 03306 - CONCRETE

PART 1: GENERAL

- 1-1 QUALITY ASSURANCE: Standards, American Concrete Institute (ACI), American Society for Testing and Materials (ASTM), and Federal Specifications (FS).
- 1-2 Coordinate these specifications with Section 90 of the Standard Specifications.

PART 2: MATERIALS

- 2-1 CEMENT: FS SS-CI92, Type I, Portland Cement, free from lumps.
- 2-2 AGGREGATE: Free from oil, alkali, organic matter, or other deleterious substances. Aggregate may consist of sand and gravel separately batched at construction site, central batching plant combined sand and gravel, or pit-run gravel, as approved, and well graded in accordance with Section 90-3.04 of the Standard Specifications, one inch maximum.
- 2-3 WATER: Potable.
- 2-4 REINFORCING STEEL BARS: FS QQ-S-632, Type II, Class B40, Intermediate, billet-steel, free from rust, scale or oil.
- 2-5 REINFORCING STEEL MESH: Welded steel fabric, ASTM A185, free from rust, scale or oil. Fabric, steel wire, FS RR-W- 375.
- 2-6 FORMS: Steel, plywood, or other approved material.
- 2-7 CURING COMPOUNDS: In accordance with Section 90-7 of the Standard Specifications.
- 2-8 ADMIXTURES: In accordance with Section 90-4 of the Standard Specifications.

PART 3: EXECUTION

- 3-1 FORMS: Construct true to line and grade, sufficiently rigid to prevent deformation under load or vibration placement of concrete. Clean and oil forms before placing concrete.
- 3-2 REINFORCING STEEL: Clean, place and secure, using metal chairs, spacers, or other approved devices. Tie wire, eighteen-gauge minimum, black annealed wire. Bending, splicing, and protection, ACI 318. Provide dowels in foundations for all vertical bars. Place reinforcement as indicated or directed.
- 3-3 PROPORTIONING AND CONTROL: Concrete, minimum of six 94-pound sacks (I. 5 barrels) of cement per cubic yard of concrete. Maximum allowable net water content, including water in aggregate, 6.5 gallons of water per sack of cement. Roadway deck slabs shall have a minimum of seven 94 pound sacks of cement per cubic yard of concrete.

- A. Consistency: Determine consistency in the field by the slump test, ASTM C143. Slump for vibrated concrete, two to four inches; for non-vibrated concrete, two to five inches.
- B. Strength: During pouring of the concrete, the contractor shall prepare standard test cylinders, which shall accurately represent the concrete placed in the forms. For each 75 cubic yards, or portions, poured each day in each separate structure, four standard cylinders shall be cast. Casting, handling, and curing of all cylinders shall be in accordance with ASTM C31. Additional cylinders may be required if an error in batching is suspected. The engineer may require that the test cylinders be prepared by inspection personnel.

Cylinders shall be tested for strength by a recognized testing laboratory at the contractor's expense and certified copies of the results shall be submitted to the engineer. One test cylinder from each group of four shall be tested at the end of seven days and three shall be tested at the end of twenty-eight days, all in accordance with ASTM C39. The minimum compressive strength for slabs and walls shall be 3000 pounds per square inch and all other structure shall be minimum 2400 pounds per square inch.

- 3-4 **MIXING**: Mix cement, aggregate, and water in an approved mechanical mixer for a minimum of 1.5 minutes before concrete placement. For small quantities, hand mixing may be permitted with approval. Remove entire content of drum before filling with materials for a succeeding batch. Mix concrete only in quantities required for immediate use. Retempering of concrete will not be permitted.
- 3-5 **PLACING**: With minimum handling, place concrete within thirty minutes after mixing. Do not drop freely more than five feet. Place concrete footings on surfaces free of mud, loose or unsound rock, or other detrimental substances. Thoroughly tamp or vibrate concrete in forms.
- 3-6 **FORMS REMOVAL**: After concrete has set, minimum twelve hours, remove forms when and as directed.
- 3-7 **CURING**: Prevent rapid drying by covering exposed surfaces with craft paper, mats, earth, wet burlap, or an approved membrane curing compound for at least seven days.
- 3-8 **PROTECTION**: After placement in forms, maintain concrete at a temperature of fifty degrees Fahrenheit for a period of seventy-two hours, and at a temperature above thirty-two degrees Fahrenheit for an additional period of three days.

PART 4: MEASUREMENT AND PAYMENT

- 4-1 Per project agreement.

SECTION 15060 - PIPE AND PIPE FITTINGS

PART 1: GENERAL

- 1-1 DESCRIPTION: The work of this section includes furnishing and installing all pipe, fittings and other appurtenances where replacement is found to be the most cost effective means of rehabilitation.
- 1-2 QUALITY ASSURANCE: See individual sections in Division 15.
- 1-3 RELATED WORK SPECIFIED ELSEWHERE: Excavation, Trenching and Backfilling - Section 02221; Concrete - Section 03306; Gravity Sewer - Section 15403.

PART 2: MATERIALS

- 2-1 PIPING: Cast iron, ductile iron or plastic pipe may be used. Alternative materials will be reviewed on a case by case basis.
- 2-2 PIPE FITTINGS: Fittings to be manufactured by the pipe manufacturer or to their specifications. Other appurtenances shall have special adapters which are compatible with both fittings and pipes. All metal fittings shall be bituminous coated and lined.

PART 3: EXECUTION

- 3-1 INSTALLATION: Shall be in accordance with the pipe manufacturer's recommendations, these specifications and the engineer's direction.
- 3-2 CLEANING: All cleaning shall be accomplished prior to testing and shall be in accordance with individual pipe sections.
- 3-3 TESTING: According to Section 15403 for the respective pipe.
- 3-4 DISINFECTION: No disinfection is required for any pipeline work.

PART 4: MEASUREMENT AND PAYMENT

- 4-1 Per project agreement.

SECTION 154030- GRAVITY SEWERS

PART 1: GENERAL

- 1-1 DESCRIPTION: The work of this section consists of furnishing and installing PVC pipe for the gravity flow sewer lines and furnishing and installing ductile iron pipe at locations where shown on and detailed in the plans.
- 1-2 RELATED WORK SPECIFIED ELSEWHERE: Excavation, Trenching and Backfilling, Section 02221; Watering, Section 02233; Clearing and Grubbing, Section 02102; Concrete, Section 03306; Pipe and Pipe Fittings, Section 15060; Roadway Repair, Section 02701.
- 1-3 QUALITY ASSURANCE: References, American National Standards Institute (ANSI); American Water Works Association (AWWA); and manufacturer's printed recommendations.

PART 2: MATERIALS

- 2-1 PIPE: Pipe and pipe fittings of the type, class and size shown on the plans shall conform to the respective specifications and other requirements specified below.
- PVC sewer pipe shall conform to the requirements of ASTM Designation D3034, Type PSM of the size as shown on the plans. Pipe joints shall be an integral part of the pipe, joining with an O-ring.
- 2-2 At locations where shown on and detailed in the plans, the contractor shall install the below listed pipe.
- A. Ductile iron pipe shall conform to the requirements of ANSI Standards A21.50 and A21.51, thickness Class 5. The pipe shall be bell and spigot with a tyton joint conforming to the requirements of ANSI Standards A21.11. Pipe shall have a coal-tar epoxy lining in conformance with AWWA Standards C210.
- 2-3 At locations shown on the plans, furnish and install casing of the size shown, meeting the requirements of the State Department of Transportation.
- 2-4 PRECAST CONCRETE MANHOLES:
- A. Precast concrete manhole parts shall conform to the requirements of ASTM Designation C478 or AASHTO Designation M199, using Type II cement conforming to ASTM Designation C150.
- B. Manhole Joints: Precast manhole shall be a commercial joint compound. Cement mortar shall consist of one part Portland cement and two parts sand by volume. Sand shall be well-graded and of such size as will pass a No. 8 sieve and shall conform to the strength requirements of AASHTO Designation M45.
- C. Miscellaneous Iron and Steel Items: Shall conform to the dimensions and details shown on the plans, and as specified herein:

Cast iron for manhole frames and covers and cleanout frames and covers shall conform to the requirements for Class 30 gray iron castings, as specified in ASTM Designation A48. The castings shall be thoroughly cleaned and coated with commercial quality, asphaltum paint. Frames and covers shall fit into their frames without rocking.

- 2-5 FLEXIBLE COUPLINGS: Shall be Smith-Blair flexible cast iron couplings series 411, Dresser Style 38, or equal or in locations where no evidence of high ground water exists, flexible couplings made of virgin poly-vinyl chloride installed with stainless steel clamps may be used.

PART 3: EXECUTION

- 3-1 EXCAVATION, TRENCHING AND BACKFILLING: Excavation of trenches, backfilling and compacting for gravity sewers shall be in accordance with the applicable requirements of Section 02221 - Excavation, Trenching and Backfilling.
- 3-2 PIPE LAYING: Shall proceed upgrade with the spigot ends of bell and spigot pipe painting in the direction of the flow. If the maximum width of the trench at the top of the pipe, specified in Section 02221, is exceeded for any reason other than by direction, the contractor shall install, at no additional cost to the owner, such higher strength pipe or improved bedding as may be required to satisfactorily support the added load of the backfill. Trenches shall be kept free from water, and pipe shall not be laid when the condition of the trench or the weather is unsuitable for such work. As work progresses, a 9 gage galvanized steel locator wire shall be installed under the centerline of all non-metallic pipe in the trench.
- A. Alignment: Each pipe shall be laid true to line and grade and in such manner as to form a close concentric joint with the adjoining pipe and to prevent sudden offsets of the flow line. Alignment and grade shall be obtained by plumbing and measuring from a tightly stretched wire or line running parallel with the flow line grade, and supported over the center line of the sewer by batterboards or bars accurately placed and firmly fastened in place across the trench.
- B. Pipe Cleaning: As the work progresses, the interior of the sewer pipe shall be cleared of all dirt and superfluous materials of every description. At times when work is not in progress, or where pipe stub-outs have been constructed, open ends of pipe and fittings shall be securely and satisfactorily closed so that no trench water, earth or other substances will enter the pipe or fittings.
- 3-3 JOINTING: The inside of bells or couplings, gasket grooves, gaskets and spigot ends shall be cleaned prior to joining pipe. All jointing surfaces shall be lubricated and the joint assembled as recommended by the respective pipe manufacturer.
- 3-4 MANHOLES: Manholes shall be constructed in the location and to the dimensions shown on the plans. The precast units shall be assembled accurately, with full-bed commercial joint compound. All manhole bases shall be four way precast units.

The top of the manhole covers shall be accurately brought to the elevations indicated on the plans, or if no elevations are indicated, they shall be brought flush with the surface of the surrounding pavement. Manholes located outside paved areas shall be constructed to a cover grade six inches above the surrounding ground. Manholes shall be constructed

with not more than twelve inches of throat section between the top of the cone and the base of the frame.

All precast concrete manhole parts and cast iron frames and covers, which are removed per plans, shall be returned to the owner. All precast concrete manhole parts and cast iron frames and covers, which are removed, shall be shipped to suitable storage site, as specified by the owner.

- 3-5 AREAS REQUIRING FILL: Areas requiring fill so as to provide protection for the pipe or manholes shall be filled with import or select excavated material similar to normal backfill material to the required grade as shown on the plans. Grading, spreading and compacting shall be as approved by the engineer.
- 3-6 PAVEMENT RESTORATION: Pavement, bases and subgrade cut or damaged during the construction of sewer facilities, shall be replaced as specified in Section 02701. Where permanent pavement cannot be placed within 24 hours after backfilling, temporary pavement shall be placed and then removed when permanent paving is installed.
- 3-7 CLEANING SEWER LINES: Pressure sewer shall be flushed with water and "balled" to ensure that all dirt, debris and obstructions are removed. Such work shall be performed in the presence of and to the satisfaction of the engineer; and the contractor shall notify said party at least one working day in advance of starting the cleaning work. Water for flushing shall be furnished and paid for by the contractor.
- 3-8 LEAKAGE TESTS: Gravity sewers and manholes shall be initially tested by the contractor for tightness after they have been completed and backfill has been placed.

All tests shall be witnessed and approved by the engineer. Water, air and equipment for tests shall be furnished and paid for by the contractor.

- A. Air Test for Gravity Sewer Lines: Shall be performed in accordance with the following:

Before this test is performed, the pipe installation shall be cleaned in the following manner:

The contractor shall furnish an inflatable rubber ball of a size that will inflate to fit snugly into the pipe to be tested. The ball may, at the option of the contractor, be used without a tag line; or a rope or cord may be fastened to the ball to enable the contractor to know and control its position at all times. The ball shall be placed in the last cleanout or manhole on the pipe to be cleaned, and water shall be introduced behind it. The ball shall pass through the pipe with only the force of the water impelling it. All debris flushed out ahead of the ball shall be removed at the first manhole where its presence is noted. In the event cemented or wedged debris, or a damaged pipe shall stop the ball, the contractor shall remove the obstruction.

Test: The contractor shall furnish test plugs; an air compressor; and personnel for conducting the acceptance test under the direction of the owner. The owner shall furnish the test gauge; stopwatch; and the supervision of the test.

Immediately following the pipe cleaning described, the pipe installation shall be tested with low-pressure air. Air shall be slowly supplied to the plugged pipe installation until the internal air pressure reaches 4.0 pounds per square inch greater than the average back pressure of any ground water that may submerge the pipe. At least two minutes shall be allowed for temperature stabilization before proceeding further.

The rate of air loss shall then be determined by measuring the time interval required for the internal pressure to decrease from 3.5 to 3.0 pounds per square inch greater than the average back pressure of any ground water that may submerge the pipe.

The pipeline shall be considered acceptable, when the time interval for the decrease in pressure exceeds that shown in the table below:

<u>Pipe Size (Inches)</u>	<u>Time</u>
4	2 min. 32 sec.
6	3 min. 50 sec.
8	5 min. 6 sec.
10	6 min. 22 sec.
12	7 min. 39 sec.

If leakage is greater than that specified above, the defective joints shall be located and repaired until the leakage is within the specified allowance, without additional cost to the owner.

- B. Manhole Leakage: All manholes shall be tested for leakage. This test shall be made by plugging all openings in the manholes, filling same with water and checking the loss in a one-hour period. The loss shall not exceed 0.25 gallons, per foot of depth, per hour. Manhole leakage in excess of the allowable maximum shall be corrected by repairs and retesting, as required.
- C. Alternate Manhole Leakage Test Method: An acceptable leakage test method for the manholes shall be by the negative air pressure (vacuum) test method. Testing shall be per ASTM Standard C924 and “Standard Practice for Testing Concrete Sewer Manholes by the Negative Air Pressure (Vacuum) Test” as prepared by Mel C. Marshall Industrial Consultants, Inc. Testing apparatus and printed detailed testing procedures are available from Teichert Precast (916) 386-6964.

3-9 Following completion of each line, connect new line to old line with the least amount of disturbance to existing customers. Notify City maintenance and cooperate in determining an appropriate time for the changeover.

PART 4: MEASUREMENT AND PAYMENT

4-1 MEASUREMENT:

- A. General: Work covered by this section will not be accepted until backfilling and tests connected with the work have been completed satisfactorily. Any section of the sewer that is found defective in material, alignment, grade or joints before acceptance shall be satisfactorily corrected by the contractor at no additional cost to the owner.
- B. Gravity Pipe: Gravity pipe of the respective sizes and types will be measured in place along the surface of the pipe by the linear foot. The measurement will be continuous through all manholes, except that said measurement will be taken to center only of manholes where sewer lines terminate.
- C. Manholes: Will be measured on the basis of each manhole type completely installed. The cost of plugged sewer stubs shall be included in the unit price bid for manholes.

All precast concrete manhole parts and cast iron frames and covers, which are removed per plans, shall be returned to the owner. All precast concrete manhole parts and cast iron frames and covers, which are removed, shall be shipped to suitable storage site, as specified by the owner.

- D. Casing: Will be measured for the respective sizes in place.

4-2 PAYMENT:

Per project agreement.

17.00 DESIGN STANDARDS - LANDSCAPING

Project specific tree, landscaping, and irrigation plans shall be provided in accordance with the requirements of City of Sutter Creek Municipal Code Section 13.24. All plans are to be prepared by a qualified landscape person and submitted to the City for approval. Upon plan approval, all trees, landscaping, and irrigation system defined therein shall be constructed by the project proponent. All landscaping must be installed prior to issuance of a building permit certificate of occupancy.

18.00 STANDARD DETAILS: STREETS, STORM DRAIN, SEWER

Index of Standard Detail Drawings

STREET DETAILS:

Typical Street Sections	ST-1
Typical Locations of Underground Utilities	ST-2
Curb, Gutter, & Sidewalk	ST-3
Typical Ramp Driveways	ST-4
Standard Residential Driveway Approach	ST-5
Driveway Profile	ST-6
Standard Driveway for Hillside Lots	ST-7
Standard Cul-De-Sac	ST-8
Intersection Bulb	ST-9
Standard Street Sign Detail	ST-10
Standard Street and Stop Sign Post Detail	ST-11
Standard Cross Gutter	ST-12
Standard Guard Panel	ST-13
Trench Restoration	ST-14
Street Light	ST-15

STORM DRAIN DETAILS:

Drain Inlet Box	SD-1
Storm Drain Manhole	SD-2
Curb & Grate Inlet	SD-3
Under Walk Drain	SD-4
Storm Drain Outfall	SD-5
Rainfall Intensity Chart	SD-6

SANITARY SEWER DETAILS:

Standard Sewer Manhole Detail	SS-1
Sewer Service Detail	SS-2
Cleanout to Grade	SS-3
Trench Detail	SS-4
Minimum Coverage Section	SS-5
Water Main Crossing Detail	SS-6
Sewer Notes	SS-7

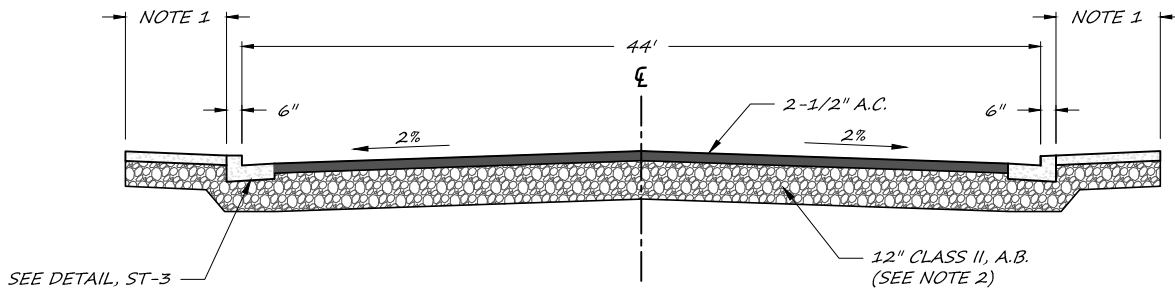

ARTERIAL

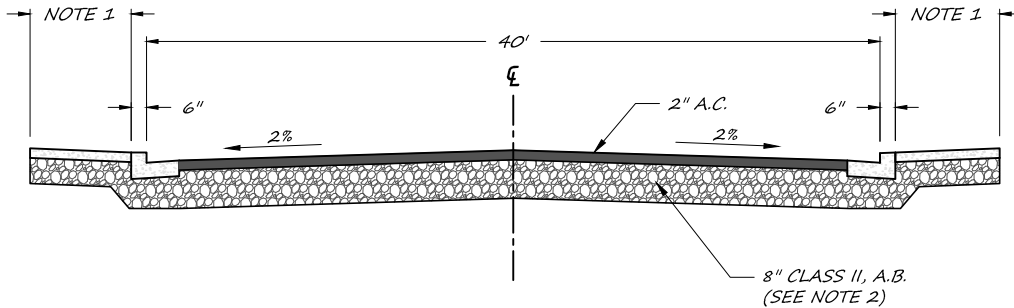

COLLECTOR

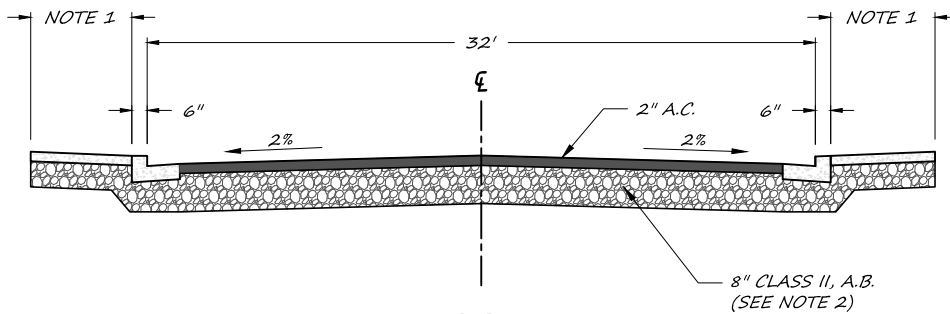

LOCAL

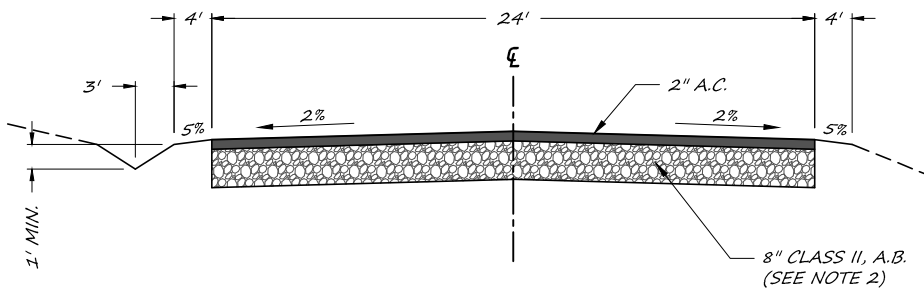

LOCAL RURAL

NOTES :

1. 6' COMMERCIAL
4' RESIDENTIAL
2. MINIMUM STRUCTURAL SECTION, PER CITY STANDARDS, ACTUAL STRUCTURAL SECTION TO BE BASE UPON R-VALUE TESTING.
3. SUBGRADE AND A.B. UNDER CURB, GUTTER & A.C., SHALL BE COMPACTED TO 95% R.C.

CITY OF SUTTER CREEK
TYPICAL STREET SECTIONS

			ST
REV No.:	DATE:	BY:	1

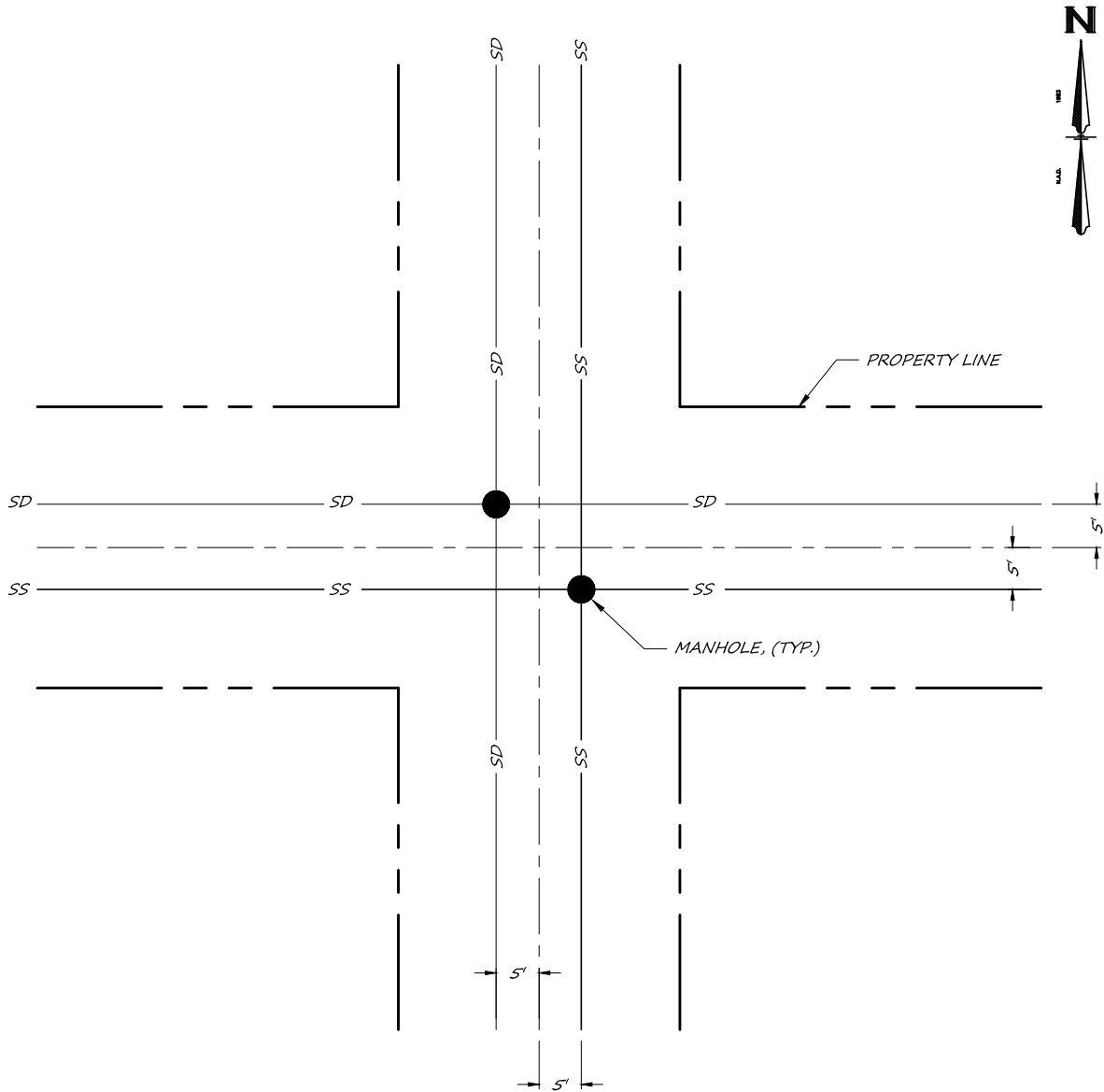

LEGEND :

- STORM DRAIN, (SD) ——— SD ———
- SANITARY SEWER, (SS) ——— SS ———
- STREET CENTERLINE - - - - -
- PROPERTY LINE - - - - -

NOTES :

1. DEVIATIONS FROM THE STANDARD LOCATIONS SHOWN SHALL BE APPROVED BY THE CITY ENGINEER.

**CITY OF SUTTER CREEK
TYPICAL LOCATION OF
UNDERGROUND UTILITIES**

			ST
			2
REV No.:	DATE:	BY:	

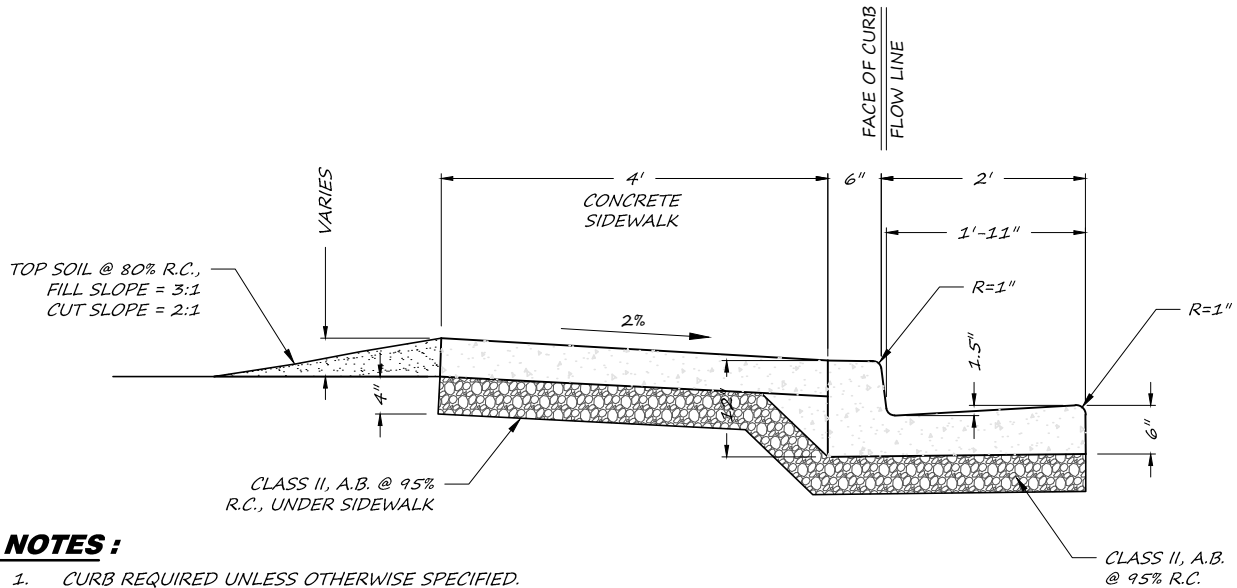

NOTES :

1. CURB REQUIRED UNLESS OTHERWISE SPECIFIED.
2. LOCATE 1/2" TRANSVERSE EXPANSION JOINTS OF ASPHALT IMPREGNATED CELOTEX IN SIDEWALK, CURB AND GUTTER AT 20' INTERVALS.
3. ALL CONCRETE TO BE CLASS "B" OR BETTER.
4. FORMS SHALL BE APPROVED BY THE CITY ENGINEER PRIOR TO PLACEMENT OF CURB AND GUTTER.

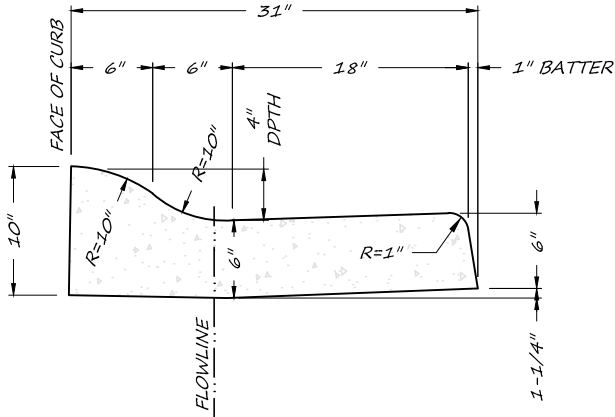

ROLLED CURB & GUTTER

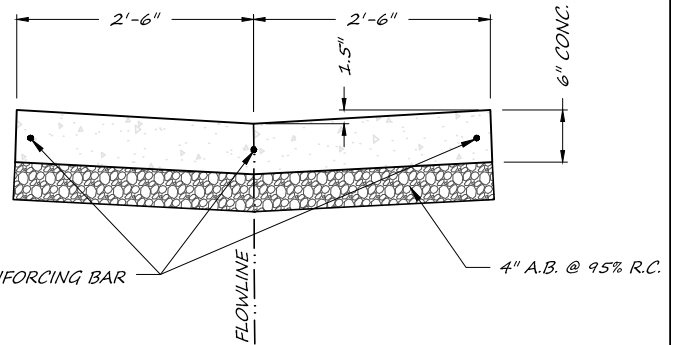

V-GUTTER

NOTES :

1. VERTICAL CURB AND GUTTER SHALL BE USED AT ALL CURB RETURNS.
2. 1/2" EXPANSION JOINT AT BOTH ENDS & MIDPOINT OF CURB RETURN
3. 1/2" WIDE EXPANSION JOINTS MAXIMUM INTERVAL 60'
4. 3/8" SCORED CONTROL JOINTS MAXIMUM INTERVAL 10'
5. GUTTER PAN WIDTH MAY BE REDUCED WITH APPROVAL OF CITY ENGINEER

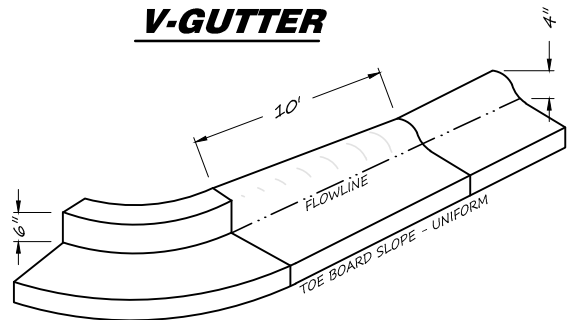

TRANSITION FROM ROLLED CURB & GUTTER TO VERTICAL CURB & GUTTER AT CURB RETURNS

**CITY OF SUTTER CREEK
CURB, GUTTER, AND SIDEWALK**

			ST
			3
REV No.:	DATE:	BY:	

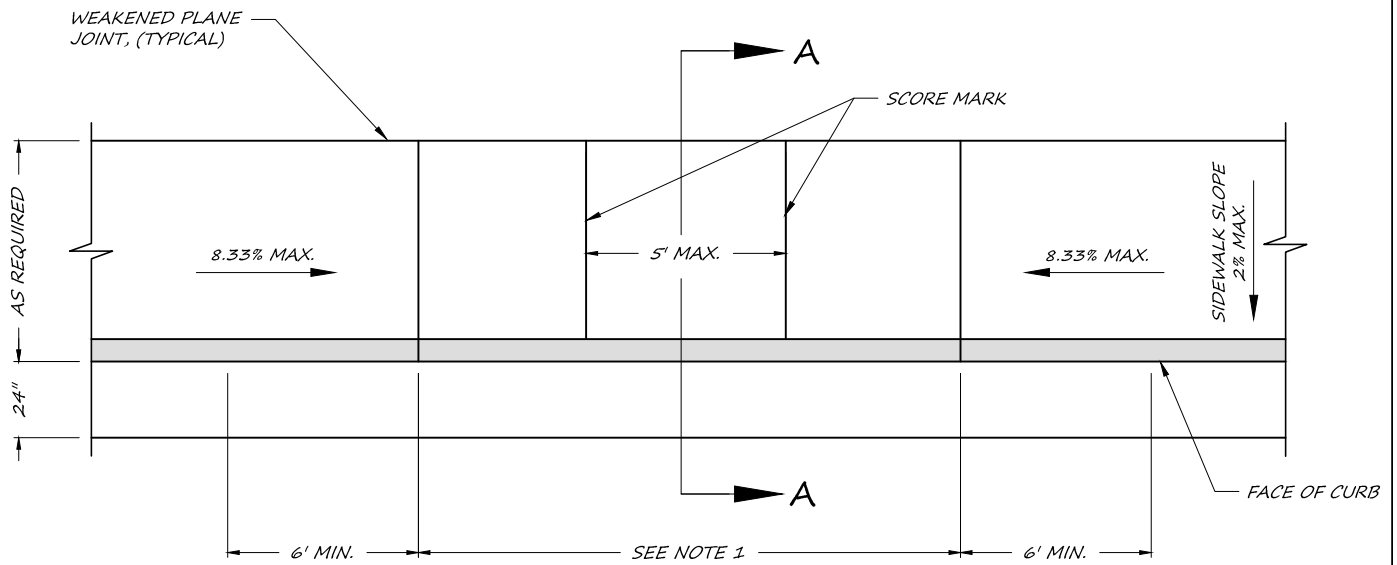

PLAN

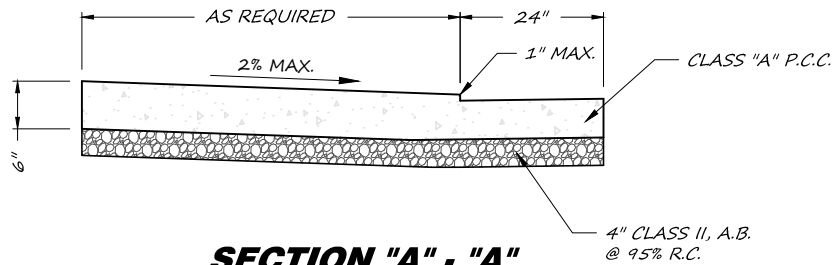

SECTION "A" - "A"

NOTES :

1. MINIMUM DRIVEWAY WIDTH SHALL BE 16' FOR RESIDENTIAL AND 24' FOR COMMERCIAL. MAXIMUM WIDTH SHALL BE 30'.
2. DRIVEWAY TO CONFORM WITH EXISTING SIDEWALK UNLESS OTHERWISE DIRECTED BY THE CITY ENGINEER.
3. IF SIDEWALK EXISTS, IT SHALL BE REMOVED AND REPLACED WITH PORTLAND CONCRETE 6" THICK
4. WHERE HIGH STREET CROWN EXISTS, DRIVEWAY RAMP MAY BE EXTENDED TO BACK OF SIDEWALK
5. WHERE DRIVEWAY PROVIDES ACCESS TO A ONE-WAY STREET, APPROPRIATE SIGNS AS SPECIFIED BY THE CITY ENGINEER WILL BE REQUIRED.
6. DRIVEWAY RAMP SHALL BE AS WIDE AS EXISTING DRIVEWAY INTO YARD, ROUNDED UP TO NEXT EVEN FOOT. (10' MINIMUM).
7. IN EVENT OF OBSTRUCTIONS IN PARKWAY, (E.G. POWER POLES ETC.), WIDTH MAY BE MODIFIED TO MEET EXISTING CONDITIONS.
8. PARKWAY WARP WINGS SHALL BE 3' FOR 6" OR HIGHER CURB. FOR 4-1/2" CURB, WARP WINGS SHALL BE 2'.
9. WHEN IT IS NOT POSSIBLE TO PROVIDE 2 LINEAL FEET OF FULL CURB HEIGHT, (WITH STANDARD 3' WARPS ON EITHER SIDE) BETWEEN ADJACENT DRIVEWAYS, A COMMON DRIVEWAY SHALL BE INSTALLED.
10. FINE HAIR BROOM FINISH ON ALL DRIVEWAYS

CITY OF SUTTER CREEK

TYPICAL RAMP DRIVEWAYS

ST

4

REV No.:

DATE:

BY:

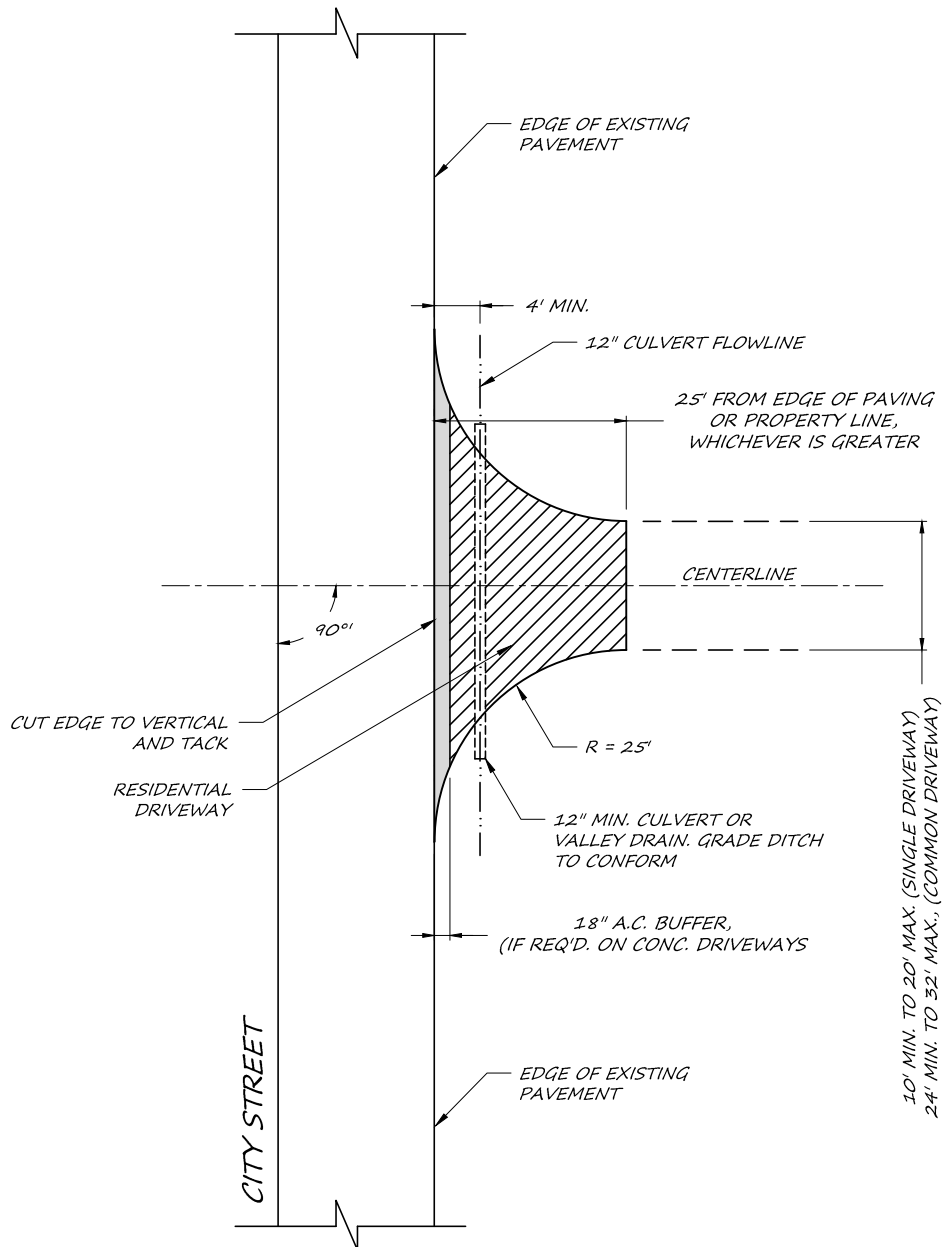

NOTES :

1. APPROACH SHALL BE CONSTRUCTED FROM ONE OF THE FOLLOWING:
 - A) 2" A.C. OVER 4" CLASS II A.B.
 - B) 6" CONCRETE w/6" x 6" x 10GA MESH OVER 2" CLASS II A.B.
 - C) ALTERNATE DESIGN SUGGESTED AND APPROVED BY THE CITY.
2. SUBGRADE INSPECTION IS REQUIRED BEFORE PLACING A.B.
3. A BASE ROCK OR SAND LEVELING COURSE INSPECTION IS REQUIRED BEFORE PLACING A.C. OR CONCRETE.
4. ALL WORK SHALL BE IN CONFORMANCE WITH CITY STANDARDS.
5. DRIVEWAY APPROACH SHALL BE AT 90° OR AS NEAR AS 90° AS POSSIBLE.
6. PERPETUAL MAINTENANCE IS THE RESPONSIBILITY OF THE PERMITTEE.

**CITY OF SUTTER CREEK
STANDARD RESIDENTIAL
DRIVEWAY APPROACH**

			ST
			5
REV No.:	DATE:	BY:	

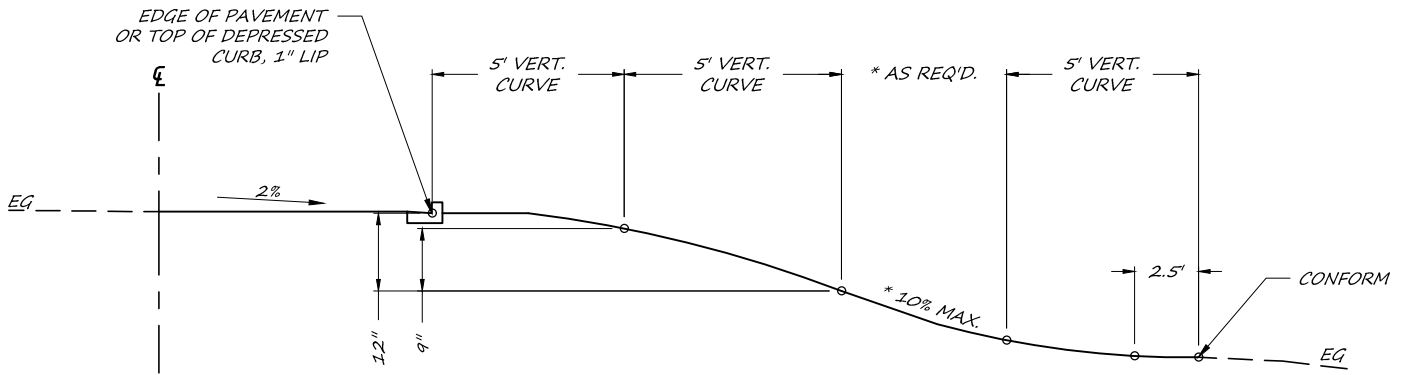

DESCENDING DRIVEWAY

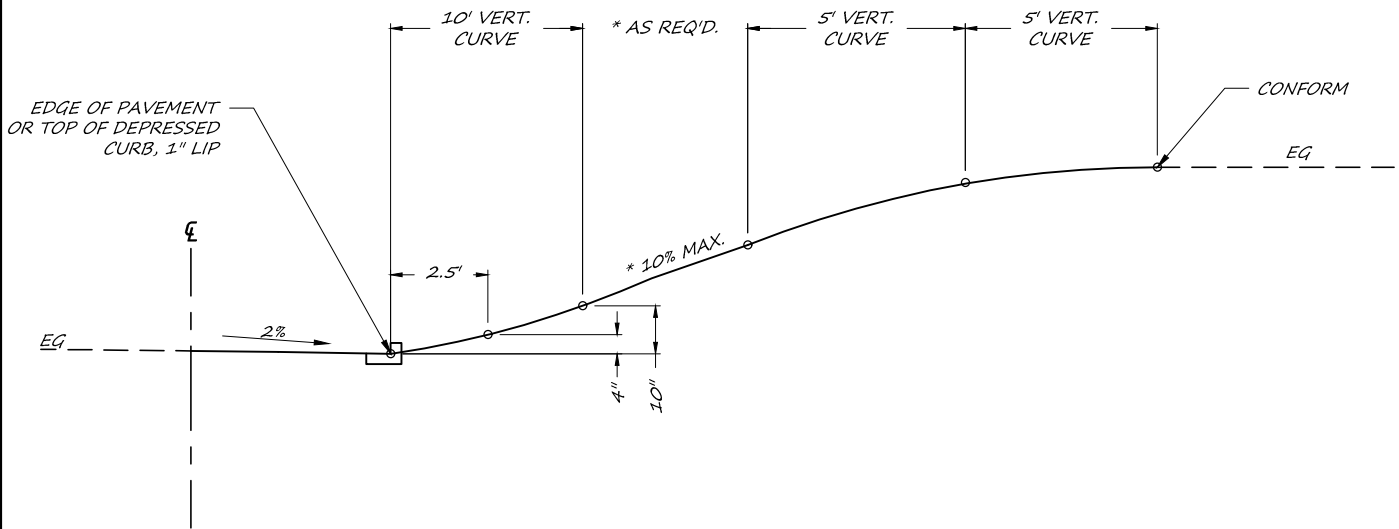

ASCENDING DRIVEWAY

* GRADE CHANGE OF 8% MAX. IN 10'.

**CITY OF SUTTER CREEK
DRIVEWAY PROFILE**

			ST
			6
REV No.:	DATE:	BY:	

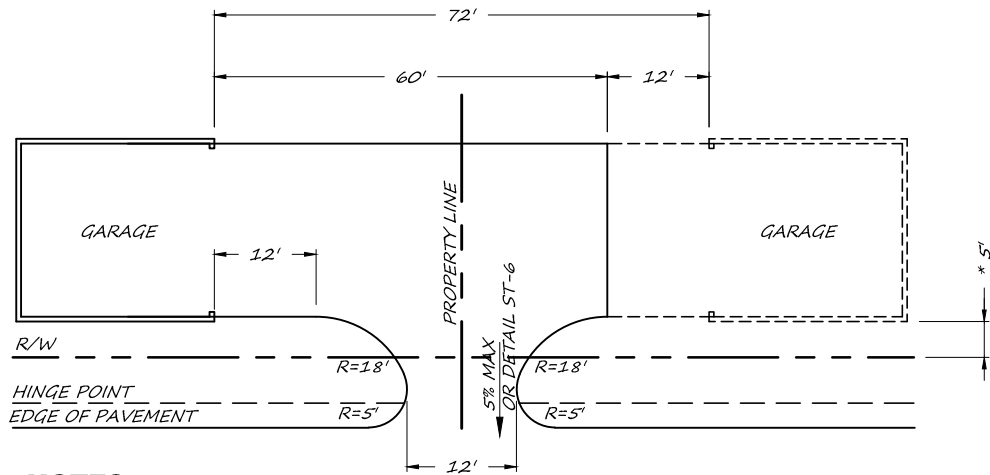

NOTES :

1. PROPERTY LINE AT CENTERLINE OF DRIVEWAY ONLY WHEN BOTH OWNERS USE SAME DRIVEWAY
2. * DEPENDS ON SETBACK REQUIREMENT

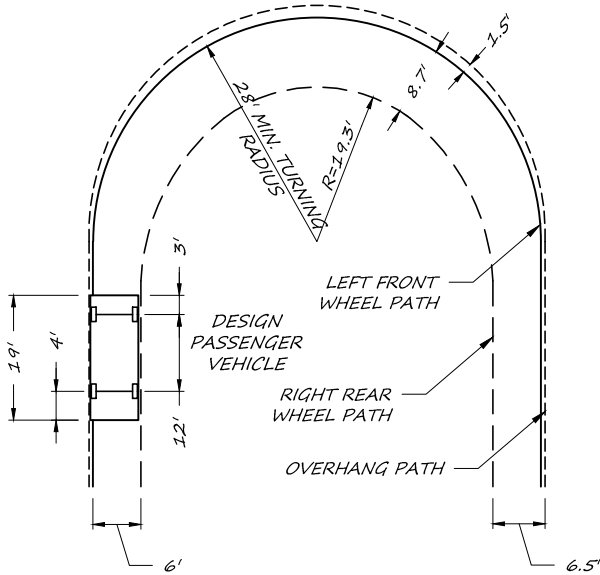

OTHER DRIVEWAY DESIGNS MAY BE APPROVED BASED ON THIS STANDARD

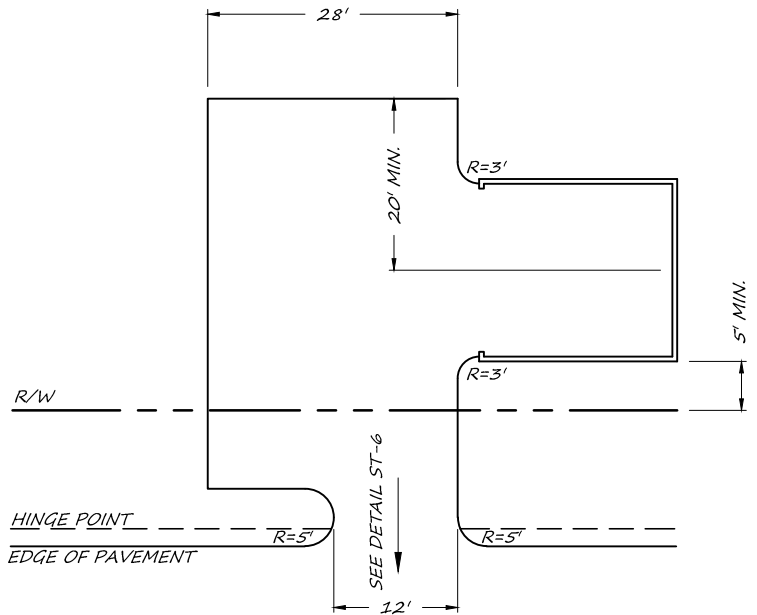

NOTE :

1. THESE STANDARDS APPLY ONLY WHEN GARAGE AND TURNING AREA ARE NEAR ROAD GRADE AND NEAR R/W.

**CITY OF SUTTER CREEK
STANDARD DRIVEWAYS
FOR HILLSIDE LOTS**

			ST
			7
REV No.:	DATE:	BY:	

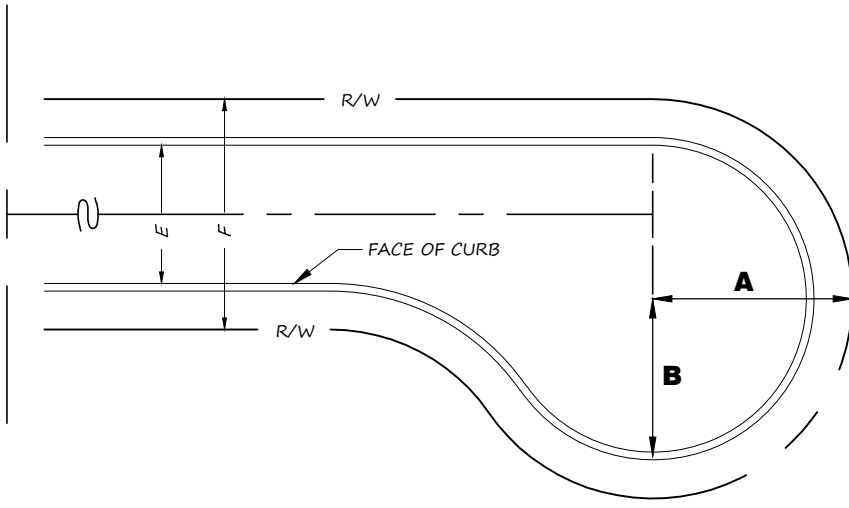
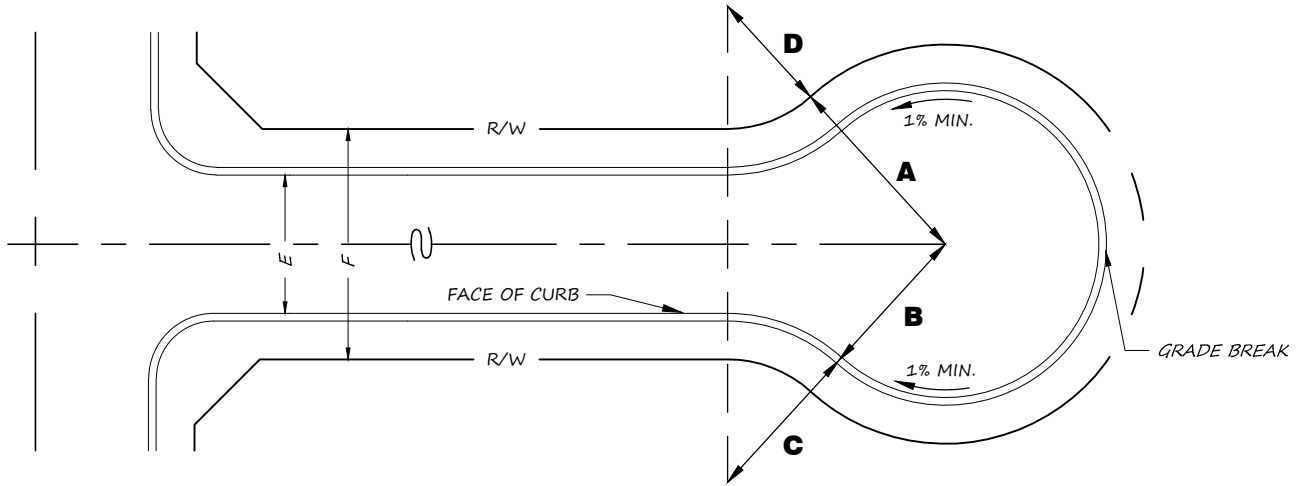

TABLE OF DIMENSIONS			
A	B	C	D
50'	40'	32'	20'

NOTES :

1. NO MORE THAN 20 SINGLE FAMILY RESIDENCES MAY BE SERVED BY A CUL-DE-SAC STREET, (OR A TEMPORARY DEAD-END STUBBED STREET).
2. DIMENSION "E" & "F" SUBJECT TO SPECIFIC PROJECT APPROVAL.
3. 500' MAXIMUM LENGTH TO CENTERLINE OF INTERSECTING STREET.
4. GUTTER SLOPE AROUND CUL-DE-SAC SHALL BE 0.005 FT./FT. MINIMUM
5. BULB DIAMETER TO BE 104' AT PROPERTY LINE.

CITY OF SUTTER CREEK
STANDARD CUL-DE-SAC

			ST
			8
REV No.:	DATE:	BY:	

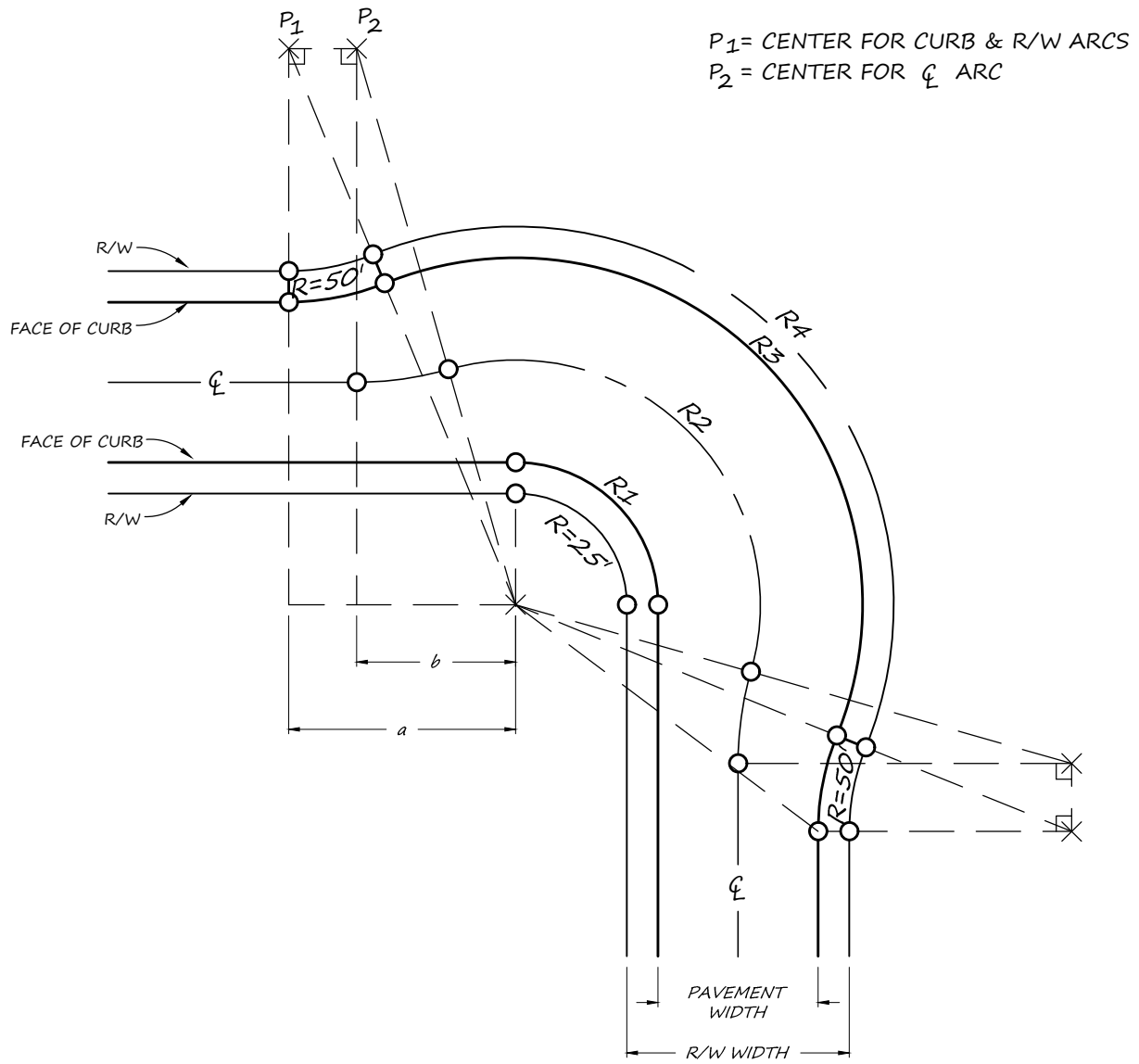

R/W WIDTH	PAVEMENT WIDTH	R_1 CURB	R_2 ϕ	R_3 CURB	R_4 R/W	a	b	P_1 TO P_2
60'	40'	35'	60'	85'	95'	52.91'	37.10'	15.81'
50'	32'	25'	60'	79'	85'	62.91'	47.10'	15.81'

NOTES:

1. KNUCKLE DIMENSIONS TO VARY PROPORTIONALLY WITH OTHER R/W AND PAVEMENT WIDTHS.
2. OTHER R/W AND PAVEMENT WIDTHS SUBJECT TO APPROVAL BY CITY ENGINEER.

CITY OF SUTTER CREEK

INTERSECTION BULB

ST

9

REV No.:

DATE:

BY:

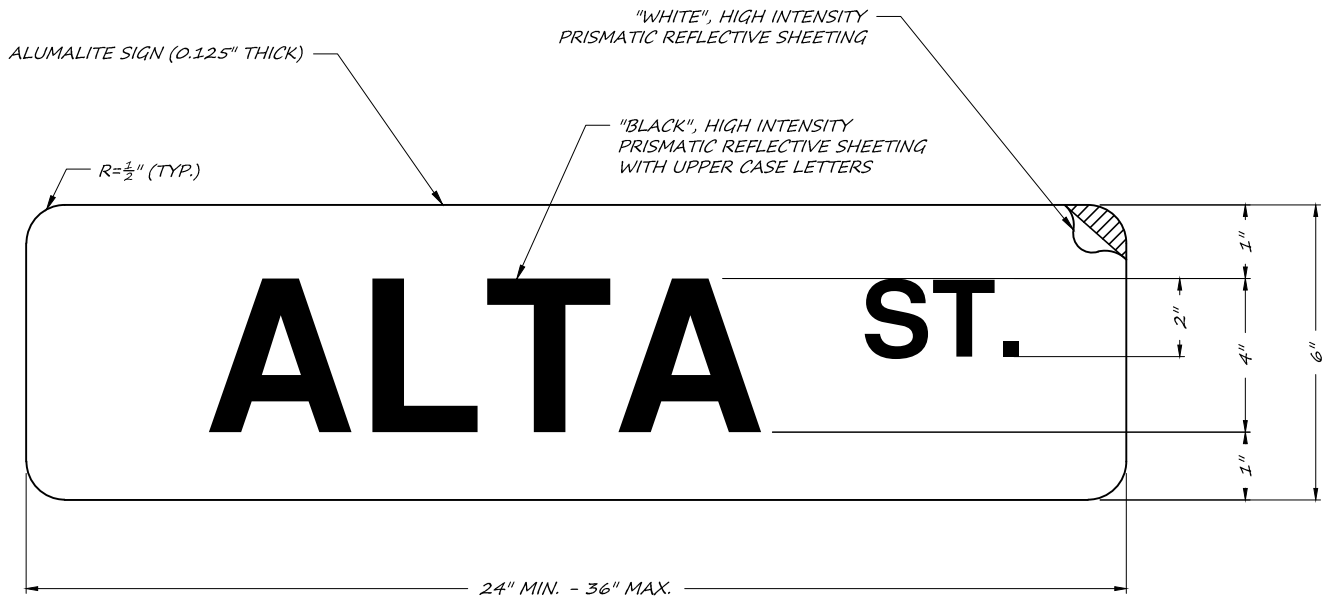

NOTES :

1. SIGNS SHALL BE PRINTED ON BOTH SIDES.
2. ALLEN HEAD SCREWS AFFIXING THE SIGN TO THE HARDWARE & CAP TO THE PIPE SHALL BE TIGHTENED, WITH HOLES THEN BEING FILLED WITH A "LIQUID METAL", IN SUCH A MANNER THAT THEIR REMOVAL IS RENDERED IMPOSSIBLE.
3. SEE STANDARD SIGN POST DETAIL ST-11..
4. CENTER LETTERS ON SIGN AND LEAVE $\frac{1}{2}"$ MIN. MARGIN ON BOTH ENDS.
5. 8-1/2" WITH BLOCK NUMBERS, BLOCK NUMBERS MAY BE REQUIRED BY CITY OR FIRE DISTRICT. BLOCK NUMBER & ARROW SHALL BE LOCATED AT THE TOP CENTER OF THE SIGN.

CITY OF SUTTER CREEK STANDARD STREET SIGN DETAIL				ST
				10
	REV No.:	DATE:	BY:	

NOTES :

1. STOP SIGN SHALL BE 30" FOR ALL STREET TYPES.
2. HIGH INTENSITY PRISMATIC REFLECTIVE SHEETING SHALL BE USED ON ALUMINUM 0.080".
3. USE STANDARD 2" I.D. GALVANIZED IRON PIPE.
4. STOP BAR & "STOP" PER CALTRANS STANDARD DETAIL.

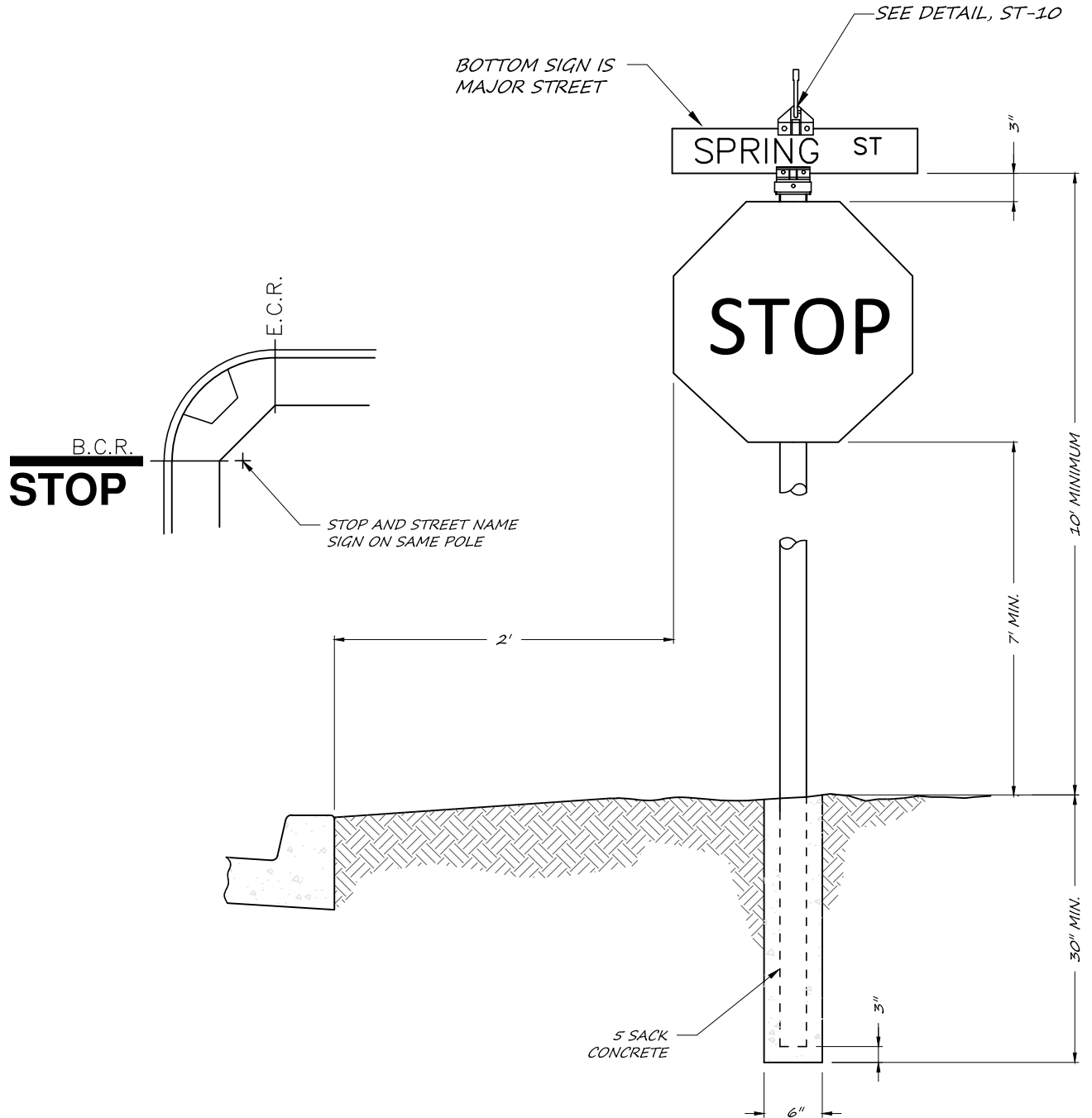

**CITY OF SUTTER CREEK
STANDARD STREET AND STOP SIGN
POST DETAIL**

				ST
				11
REV No.:	DATE:	BY:		

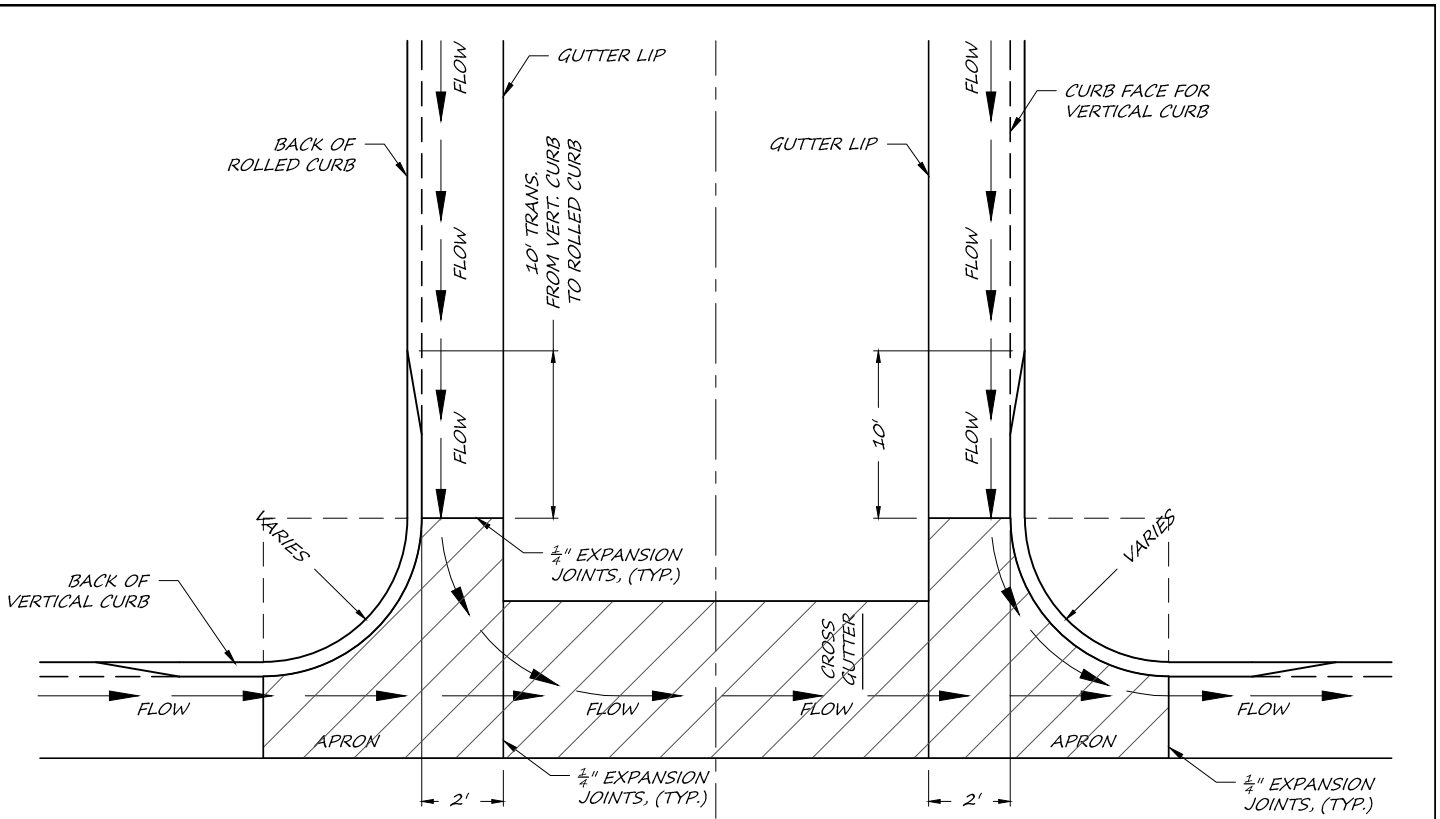

PLAN VIEW

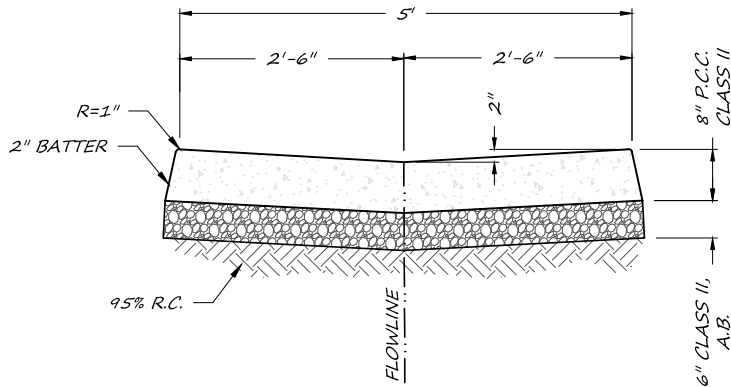

TYPICAL SECTION

NOTES :

1. ENTIRE APRON SHALL BE CLASS II, (6 SACKS / CU. YD.) CONCRETE 8" THICK THROUGHOUT.
2. VERTICAL CURB SHALL BE USED ON ALL CURB RETURNS.
3. EXPANSION JOINTS SHALL BE PLACED AT EACH END OF CROSS GUTTERS AND AT MID-SPAN, PERPENDICULAR TO THE LONGITUDINAL AXIS.
4. CROSS GUTTERS MAY BE USED ONLY WHEN OTHER DRAINAGE SOLUTIONS ARE UNAVAILABLE.



CITY OF SUTTER CREEK

STANDARD CROSS GUTTER

			ST
			12
REV No.:	DATE:	BY:	

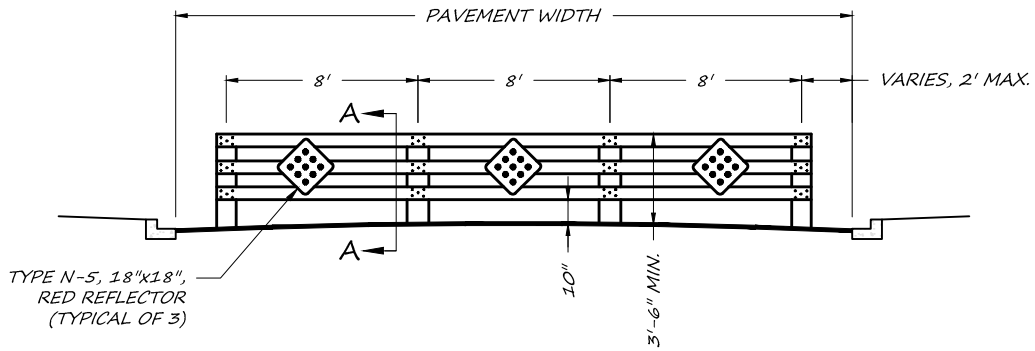

FRONT ELEVATION

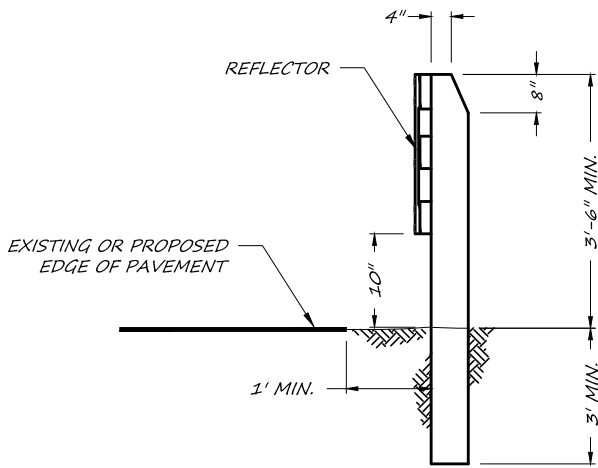

SECTION "A" - "A"

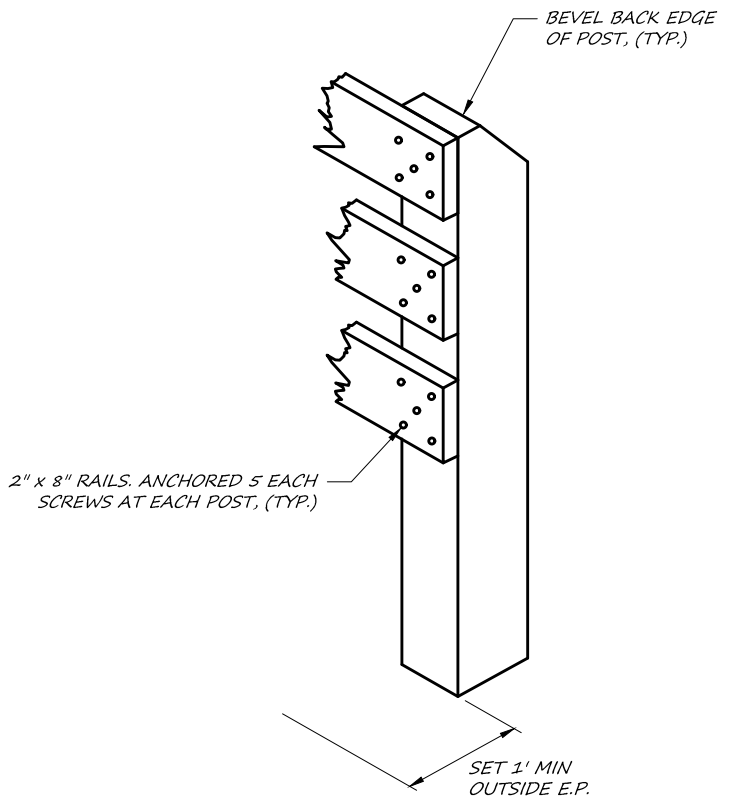

ISOMETRIC

NOTES :

1. RAILS TO BE 2" x 8" CLEAR DOUGLAS FIR S4S, AND POSTS TO BE 6" x 6" PRESSURE TREATED DOUGLAS FIR.
2. BUTT ALL RAIL JOINTS ON CENTER OF POSTS, AND ADD ADDITIONAL SCREWS AS DIRECTED.
3. ALL EXPOSED WOOD SHALL BE PAINTED WHITE, 2 COATS OF EXTERIOR ALKYD RESIN HI-GLOSS ENAMEL OR APPROVED EQUAL.
4. STANDARD TYPE N-5, 18" x 18" REFLECTOR TO BE CENTERED BETWEEN BARRICADE POSTS..

CITY OF SUTTER CREEK

STANDARD GUARD PANEL

			ST
			13
REV No.:	DATE:	BY:	

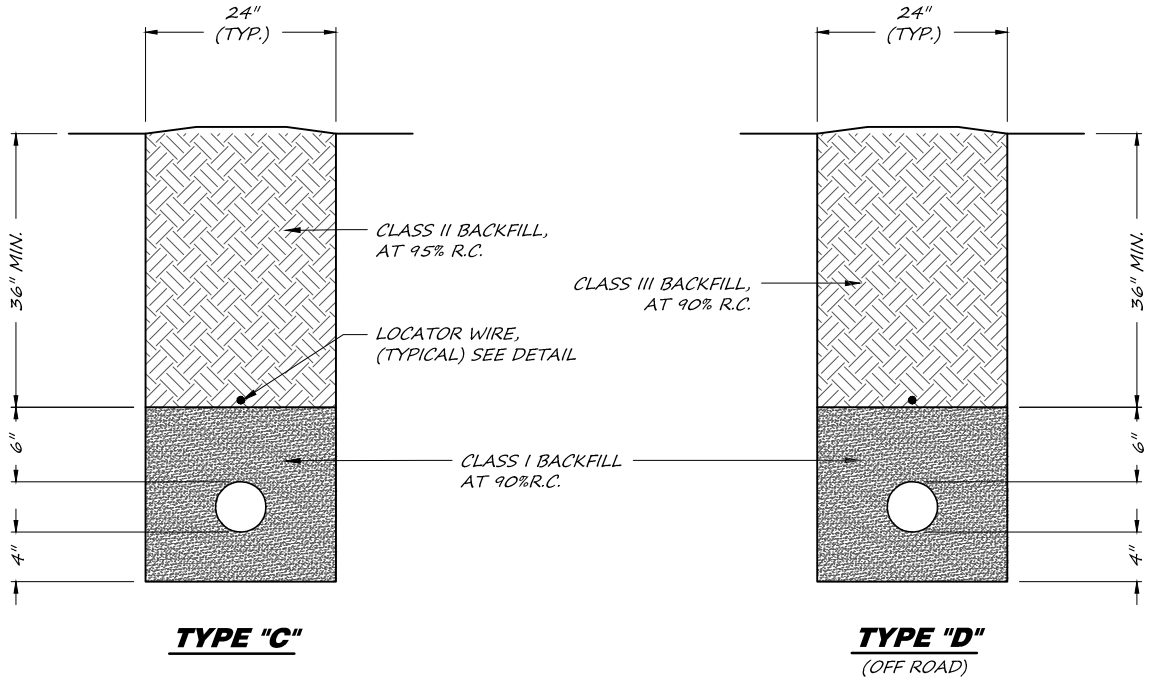
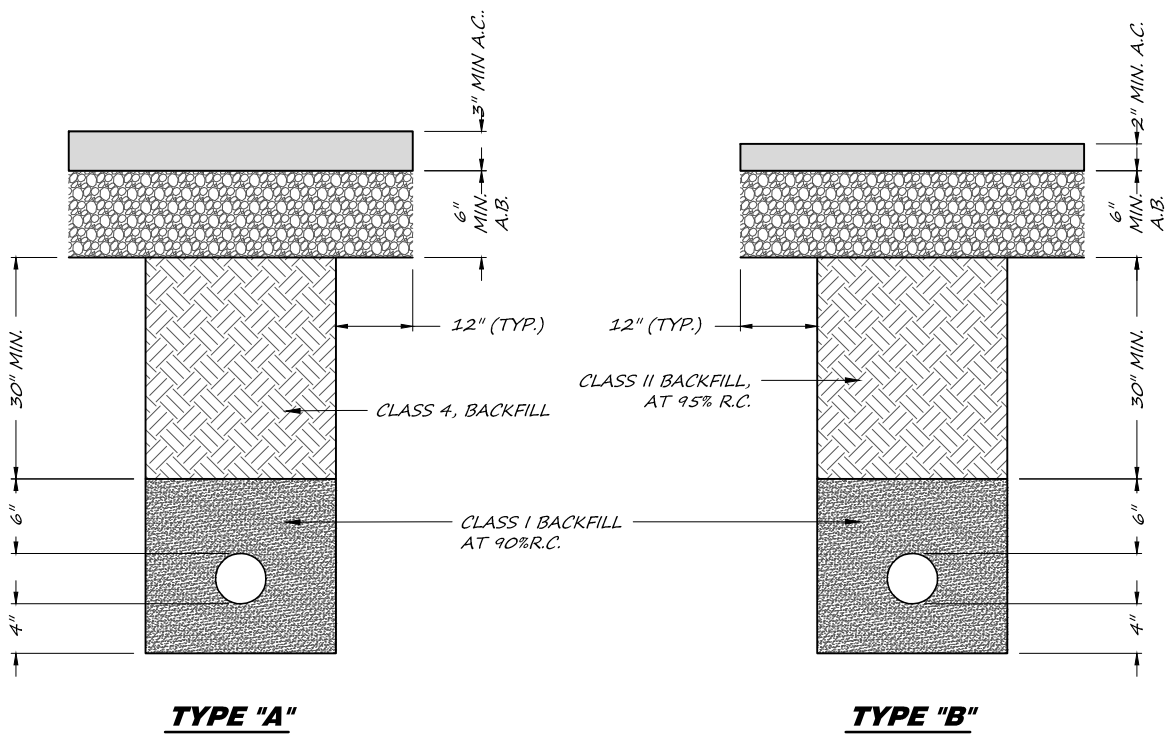

CITY OF SUTTER CREEK

TRENCH RESTORATION

			ST
			14
REV No.:	DATE:	BY:	

NOTES :

1. ASTM A307 ANCHOR BOLTS ARE REQUIRED FOR EACH POLE. PROVIDE A HEX NUT, LEVELING NUT AND (2) WASHERS FOR EACH BOLT.
2. HAND HOLES SHALL BE ORIENTED ON THE POLE SO THAT A TECHNICIAN FACING THE HAND HOLE IS ALSO FACING ONCOMING TRAFFIC.
3. CAP SCREWS SHALL BE TIGHTENED BY THE TURN-OFF-NUT METHOD, 1/3 TURN TO FORM A SNUG TIGHT CONDITION. NO WASHER WILL BE REQUIRED.
4. DURING POLE ERECTION, THE POST SHALL BE RAKED AS NECESSARY WITH THE LEVELING NUTS TO PROVIDE A PLUMB POLE AXIS.
5. ELECTROLIER IDENTIFICATION DECALS TO BE ASSIGNED BY PG&E.
6. OUTSIDE DIAMETER WALL THICKNESS AND CORRESPONDING SECTION PROPERTIES AS SHOWN IN THE CITY STANDARDS ARE MINIMUMS UNLESS OTHERWISE SPECIFIED, ALTERNATIVE SECTIONS REQUIRE APPROVAL BY THE CITY ENGINEER.
7. STREET LIGHT LUMINAIRE SHALL BE LED AND SOLAR POWER WHERE POSSIBLE.

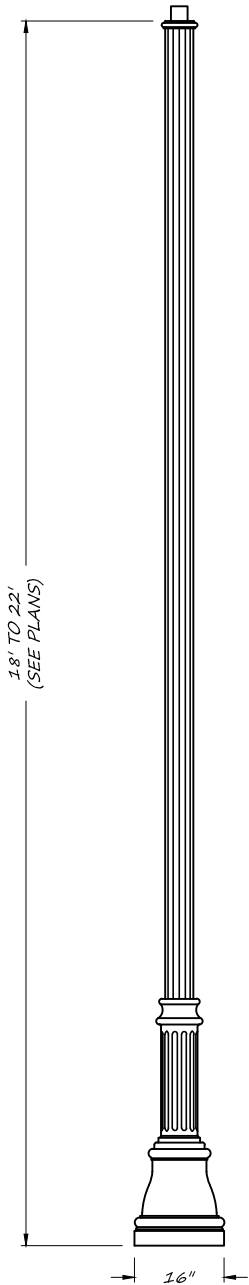

**CHARLESTON,
STYLE 5\"/>**

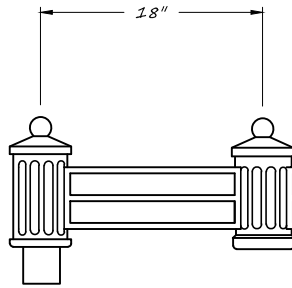

**BRACKET ARM,
(PHILADELPHIA)**

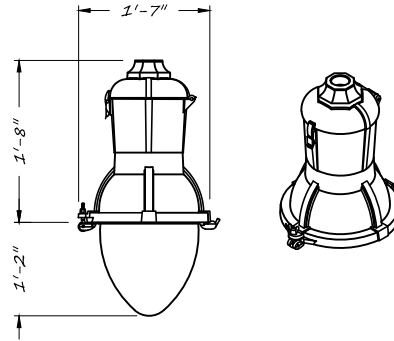

**TEARDROP LUMINAIRE,
(MEMPHIS)**

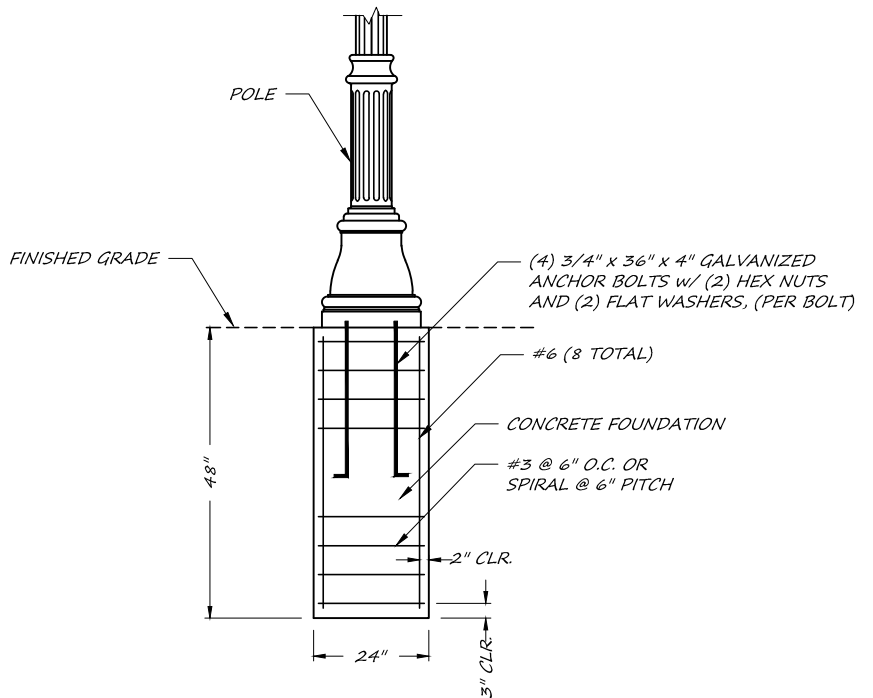

**FOUNDATION DETAIL
FOR CITY DECORATIVE STREETLIGHT**

CITY OF SUTTER CREEK

STREET LIGHT

ST

15

REV No.:

DATE:

BY:

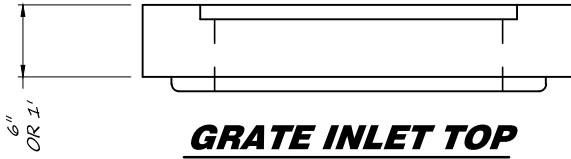

GRATE INLET TOP

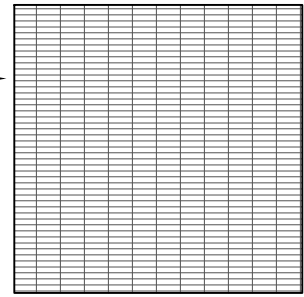

*24" x 24", CAST-IN GALVANIZED
FRAME AND GRATE*

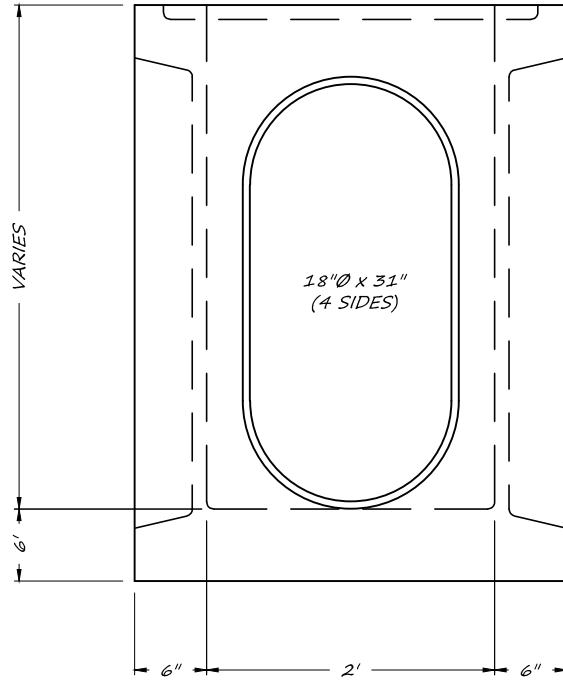

END VIEW

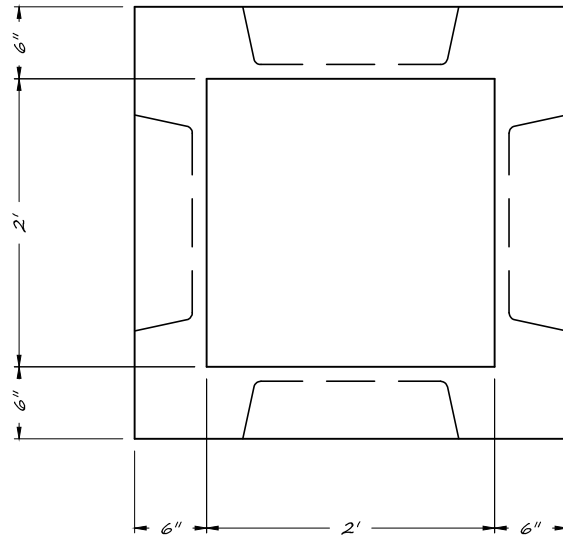

PLAN VIEW

CITY OF SUTTER CREEK

DRAIN INLET BOX

			SD
			1
REV No.:	DATE:	BY:	

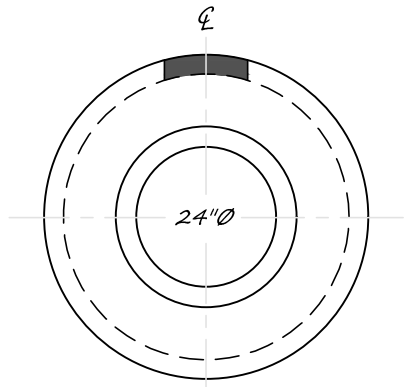

PLAN VIEW

NOTES :

1. ALL JOINTS BETWEEN PRECAST SECTIONS SHALL BE MORTARED, INSIDE AND OUTSIDE.
2. INTERIOR OF THE MANHOLE SHALL HAVE A SMOOTH TROWELED SURFACE.
3. MANHOLE COVER SHALL HAVE THE WORDS "STORM DRAIN" MOLDED INTO THE COVER, WITH PICK HOLE AND EDGE HOLE.
4. PIPES LARGER THAN 24" REQUIRE A SPECIAL DESIGN.
5. CONSTRUCT STORM DRAIN BOX WITH DECK AND KEY FOR PRECAST TAPERED CONE, FOR A FULL DECK BEARING. ALL CONSTRUCTION JOINTS TO BE APPROVED BY CITY ENGINEER.
6. REINFORCED CONCRETE GRADE RINGS, CONES, PIPE RISERS OR APPROVED PRECAST MANHOLE SECTIONS SHALL CONFORM TO CURRENT A.S.T.M. SPEC. No. C-478.

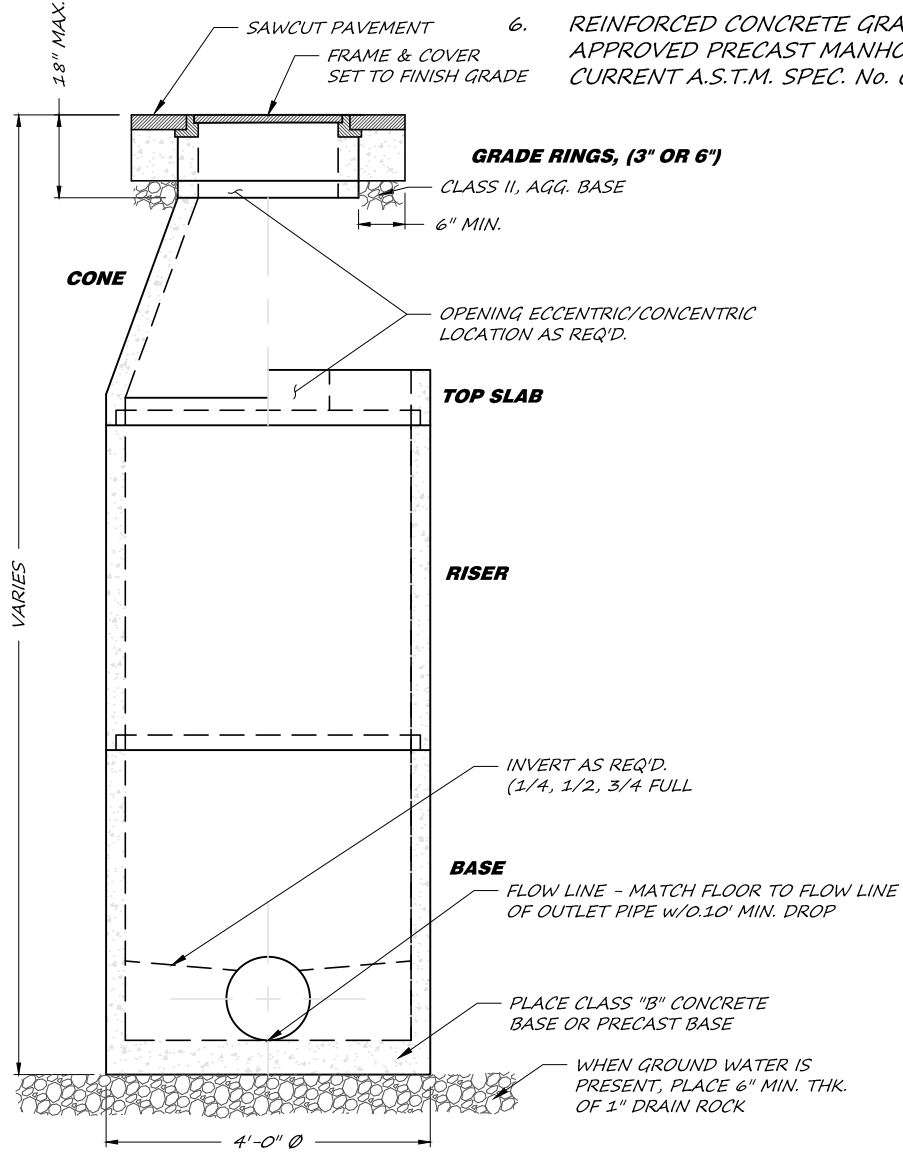

ELEVATION VIEW

CITY OF SUTTER CREEK
STORM DRAIN MANHOLE

			SD
			2
REV No.:	DATE:	BY:	

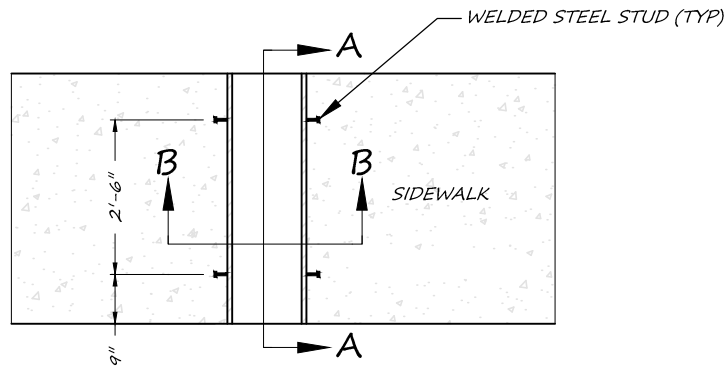

PLAN VIEW

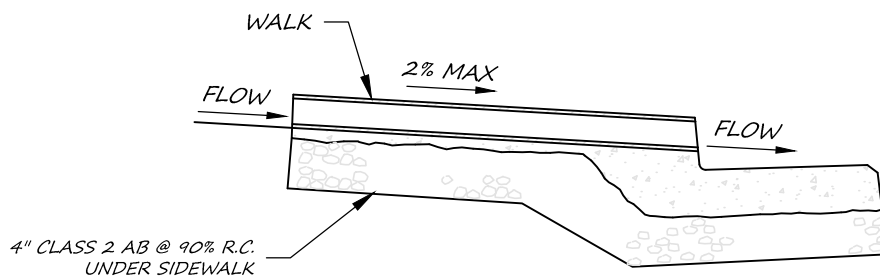

SECTION A-A

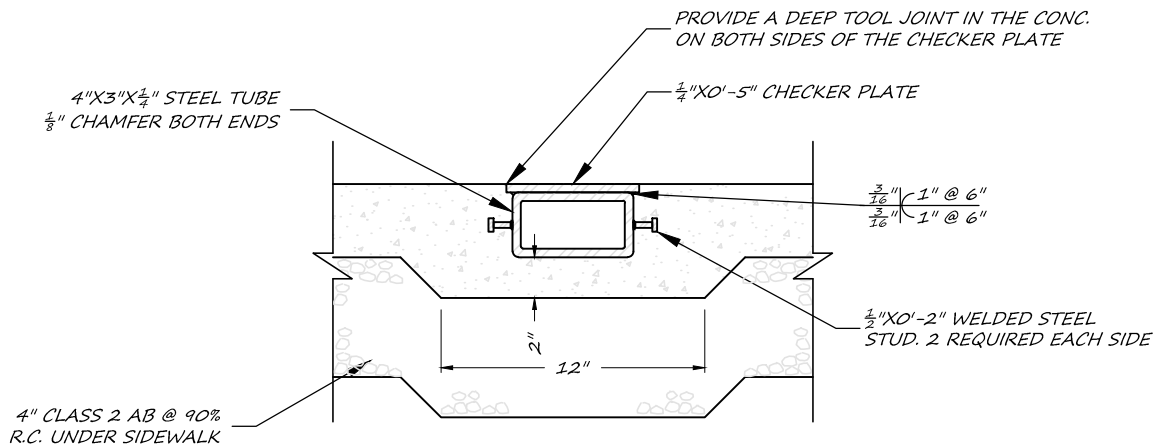

SECTION B-B

NOTES:

1. GALVANIZE AFTER FABRICATION.

CITY OF SUTTER CREEK

UNDER WALK DRAIN

			SD
			4
REV No.:	DATE:	BY:	

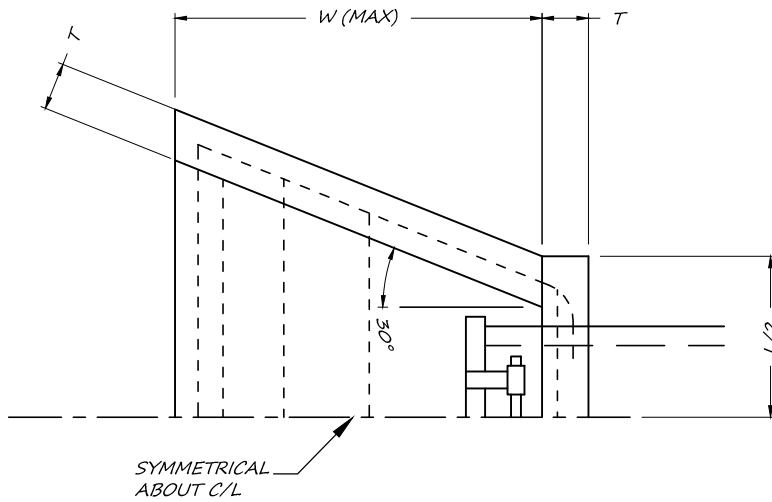

PLAN

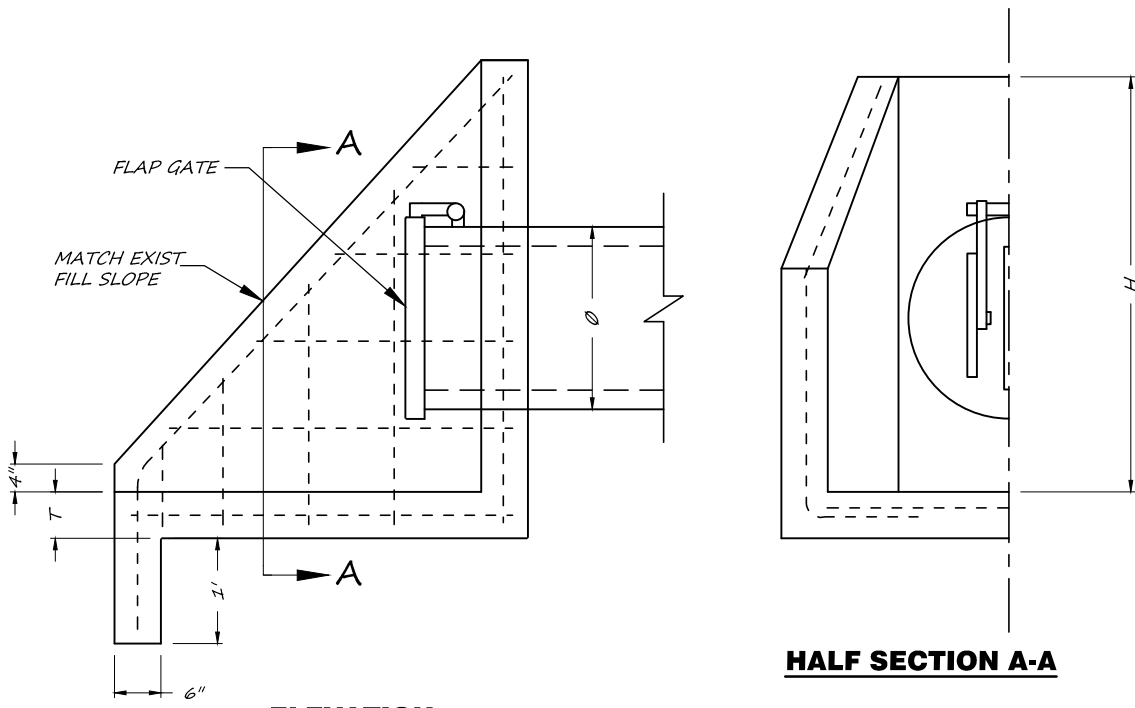

ELEVATION

HALF SECTION A-A

- NOTES:
 1. REINFORCING BAR SPACING & HEAD WALL DIMENSIONS SHALL COMPLY WITH CALTRANS DETAIL RSP D89 OR AS APPROVED BY CITY ENGINEER.

CITY OF SUTTER CREEK

STORM DRAIN OUTFALL

			SD
			5
REV No.:	DATE:	BY:	

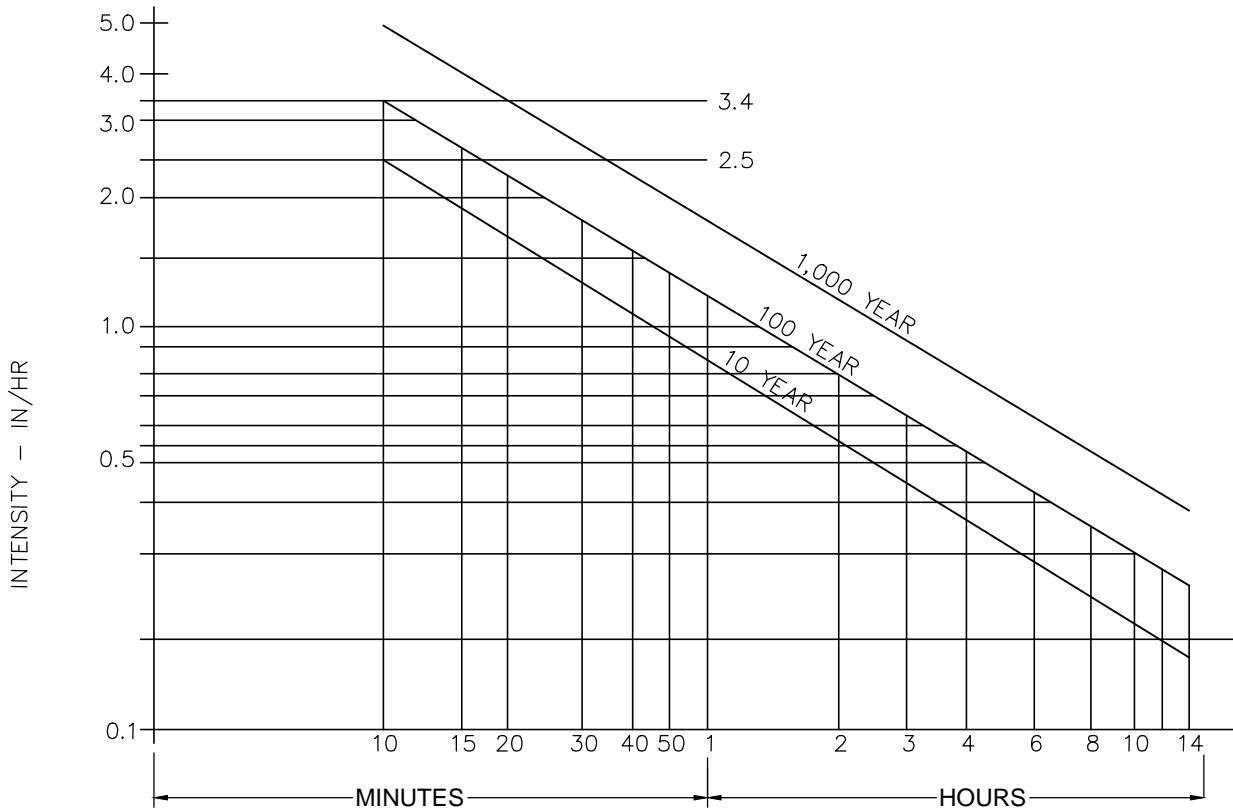

t_c = DURATION (TIME OF CONCENTRATION)

SLOPE	VELOCITY - FT. / SEC		
	OVERLAND	UNPAVED CHANNEL	PAVED GUTTER
< - .005	.25	2 - 3	1.0 - 1.7
.005 - .015	.50	3 - 6	1.7 - 3.0
.015 - .030	.75	6 - 8	3.0 - 4.2
.030 - .060	1.00	8 - 10	4.2 - 5.4
.060 - .10	1.50	10 - 13	5.4 - 7.8
.10 - .15	2.00	13 - 14	7.8 - 10
.15 - <	3.00	15	10

INSTRUCTIONS:

1. SELECT VELOCITY FROM TABLE AT LEFT
2. $t_c = L/\sqrt{v} \times 60$, SEE FIGURE I-6 OF STREET AND HIGHWAY DRAINAGE VOLUME 1 (ITTE)
3. IN CHART, GO VERTICAL TO STORM FREQUENCY CURVE DESIRED, THEN HORIZONTAL TO READ THE INTENSITY.

NOTES:

CURVES ARE BASED ON DATA FROM P.G.&E. RAINFALL RECORDS & U.S. DEPARTMENT OF COMMERCE PRECIPITATION FREQUENCY ATLAS FOR WESTERN U.S.

CITY OF SUTTER CREEK
RAINFALL INTENSITY CHART

			SD
			6
REV No.:	DATE:	BY:	

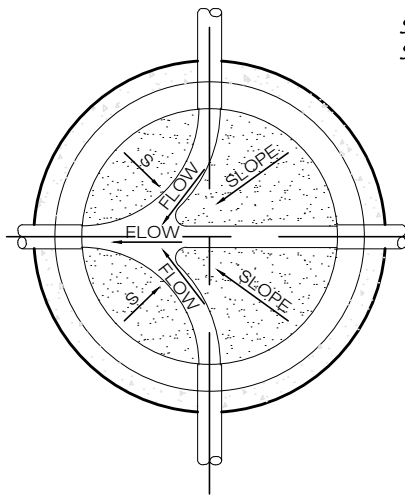

SEE DETAIL SS-7 FOR ADDITIONAL INFORMATION.
SEE NOTE 21 FOR ADDITIONAL INFORMATION.

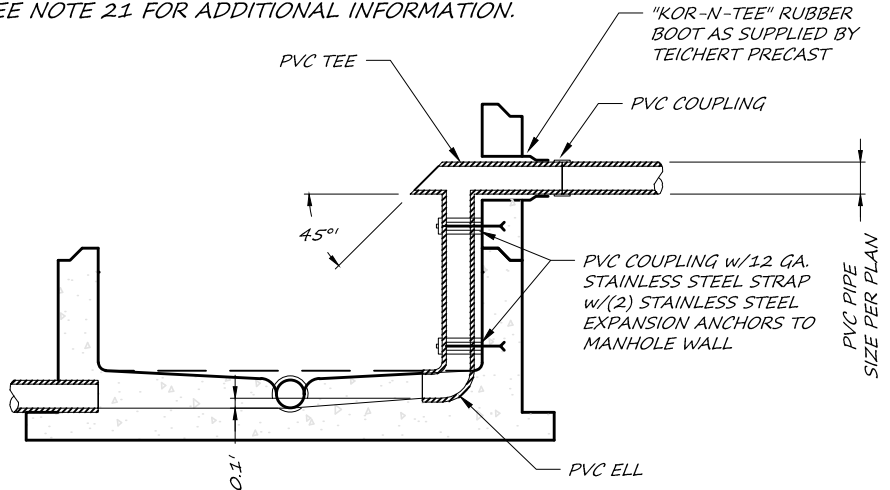

MANHOLE HEIGHT / DIAMETER CHART	
HEIGHT IN FEET	INSIDE DIAMETER IN FEET
≤8	4
>8 AND ≤12	5
>12	6

DROP CONNECTION DETAIL

NOTES:

- ① REINFORCED CONCRETE GRADE RINGS, CONES, PIPE RISERS OR APPROVED PRECAST MANHOLE SECTIONS SHALL CONFORM TO CURRENT ASTM SPEC. NO. C-478 (TEICHERT PRECAST).
- ② ALL INLETS AND OUTLETS FROM MANHOLE STRUCTURES SHALL HAVE A FACTORY INSTALLED "KOR-N-TEE" RUBBER BOOT AS PROVIDED BY TEICHERT PRECAST OR EQUIVALENT.
- ③ RUBBER GASKETS SHALL BE "RAMNECK". GASKET PRIMER SHALL BE USED AT ALL JOINTS.
- ④ SEE SPECIFICATIONS FOR REQUIRED WATER-TIGHTNESS TESTING AT JOINTS.
- ⑤ MANHOLE LIDS SHALL BE SIZED AS FOLLOWS: 4' DIA. MANHOLE = 2' DIA. LID, 5' DIA. MANHOLE = 2' DIA. LID, AND 6' DIA. MANHOLE = 2' DIA. LID.

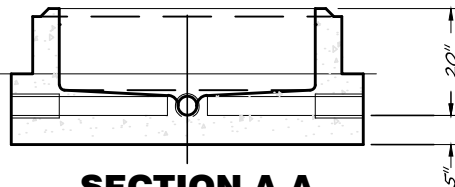
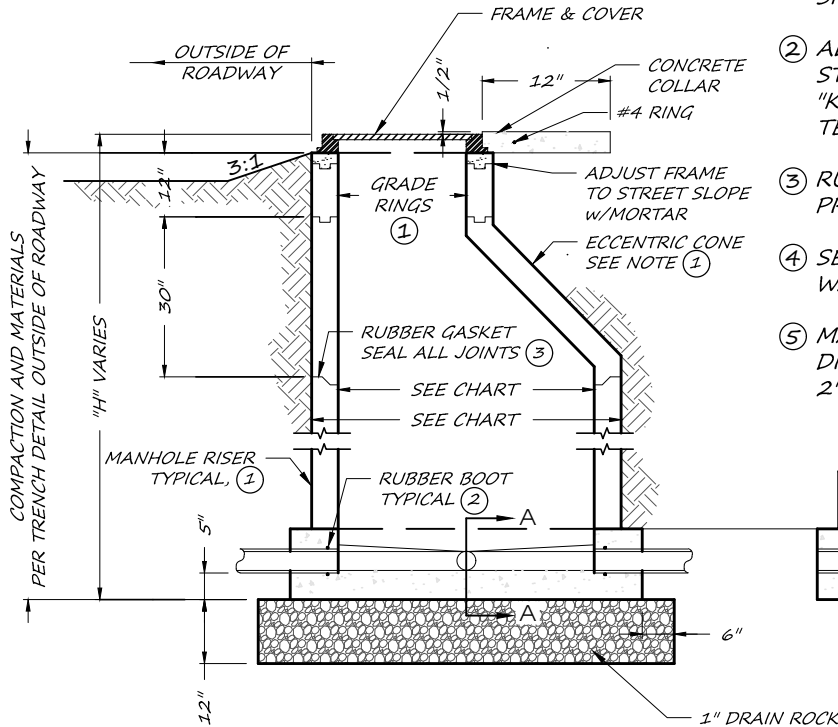

CITY OF SUTTER CREEK				SS
	STANDARD SEWER MANHOLE DETAIL			
	REV No.:	DATE:	BY:	

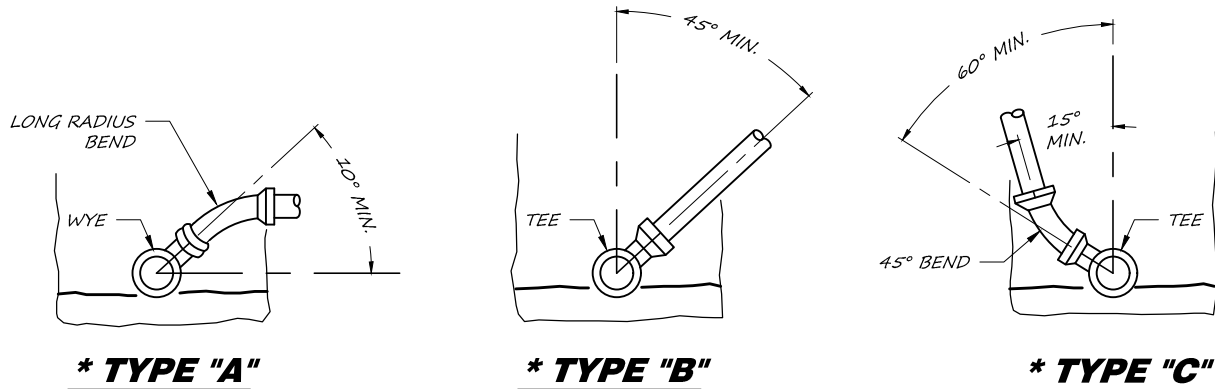
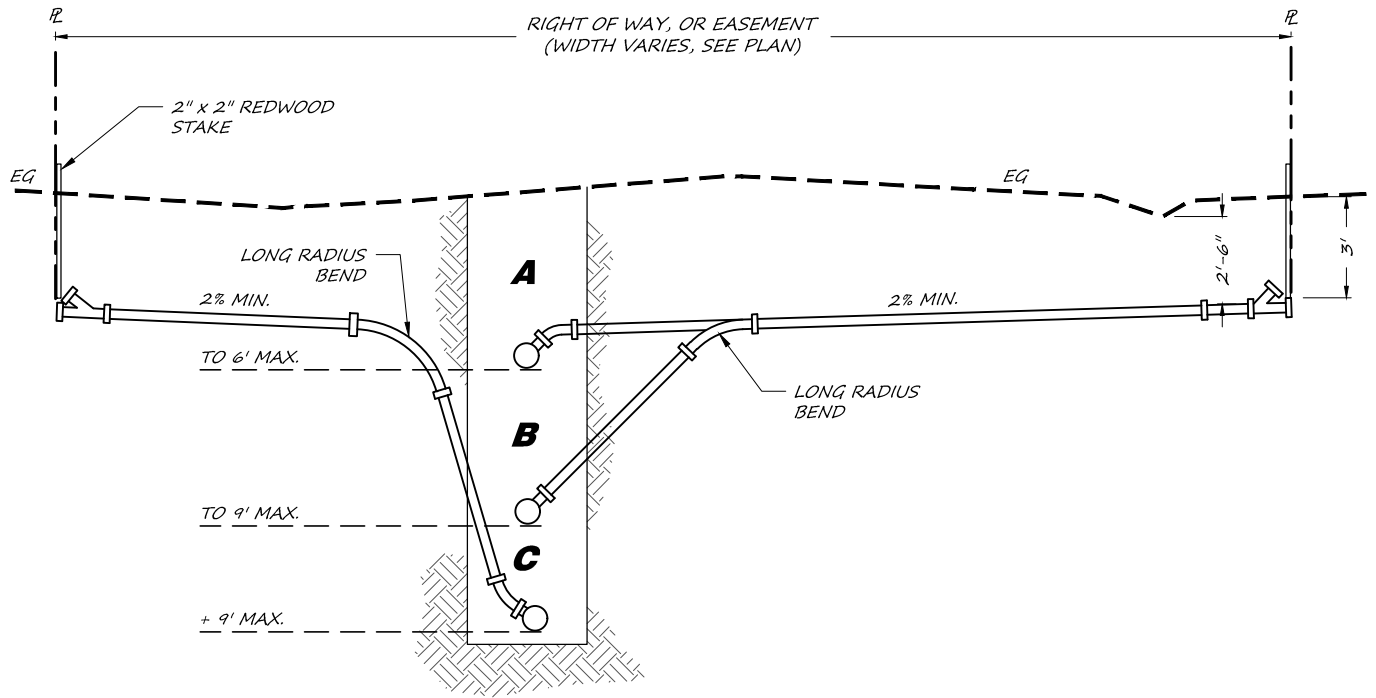

CONNECTION DETAILS

NOTES :

1. ALL SERVICE LINES SHALL BE 4" I.D. U.N.O.
2. SERVICES SHALL HAVE SAME BEDDING AND BACKFILL AS LATERAL SEWER.
3. CONTRACTOR SHALL USE THE MOST APPROPRIATE TYPE OF CONNECTION, (A, B OR C) FOR THE PARTICULAR SITUATION ENCOUNTERED.
4. SERVICE SEWER SHALL HAVE A MINIMUM 3' COVER AT PROPERTY LINE.
5. PLACE CONCRETE 12" WIDE OR WELL COMPACTED BEDDING MATERIAL 18" WIDE UNDER WYE BRANCH AND FITTINGS, AND UNSUPPORTED PIPE. WHEN BEDDING MATERIAL IS USED, PLACE ADDITIONAL MATERIAL TO TOP OF BEND, THE FULL WIDTH OF THE TRENCH.
6. INSTALL OSCAR VALVE OR APPROVED BACKFLOW PREVENTION DEVICE AS REQUIRED ON SERVICE LINE.
7. WHERE REQUIRED PLACE CHRISTY B-5 UTILITY BOX WITH COVER MARKED "SEWER" OVER CLEANOUTS CUT TO GRADE.

CITY OF SUTTER CREEK

SEWER SERVICE DETAIL

				SS
				2
REV No.:	DATE:	BY:		

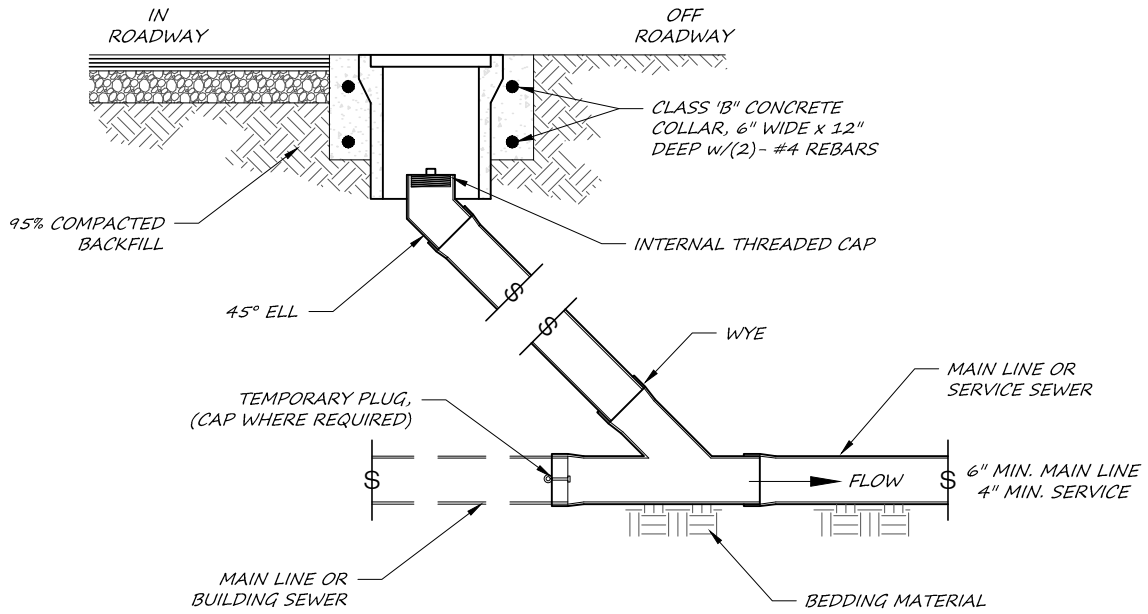

NOTES:

ALL PIPE AND FITTINGS SHALL BE THE SAME SIZE AND MATERIAL AS THE HORIZONTAL PIPE IN WHICH THEY CONNECT. JOINT SHALL BE AS SPECIFIED FOR THE TYPE OF PIPE USED.

CITY OF SUTTER CREEK

CLEANOUT TO GRADE

			SS
			3
REV No.:	DATE:	BY:	

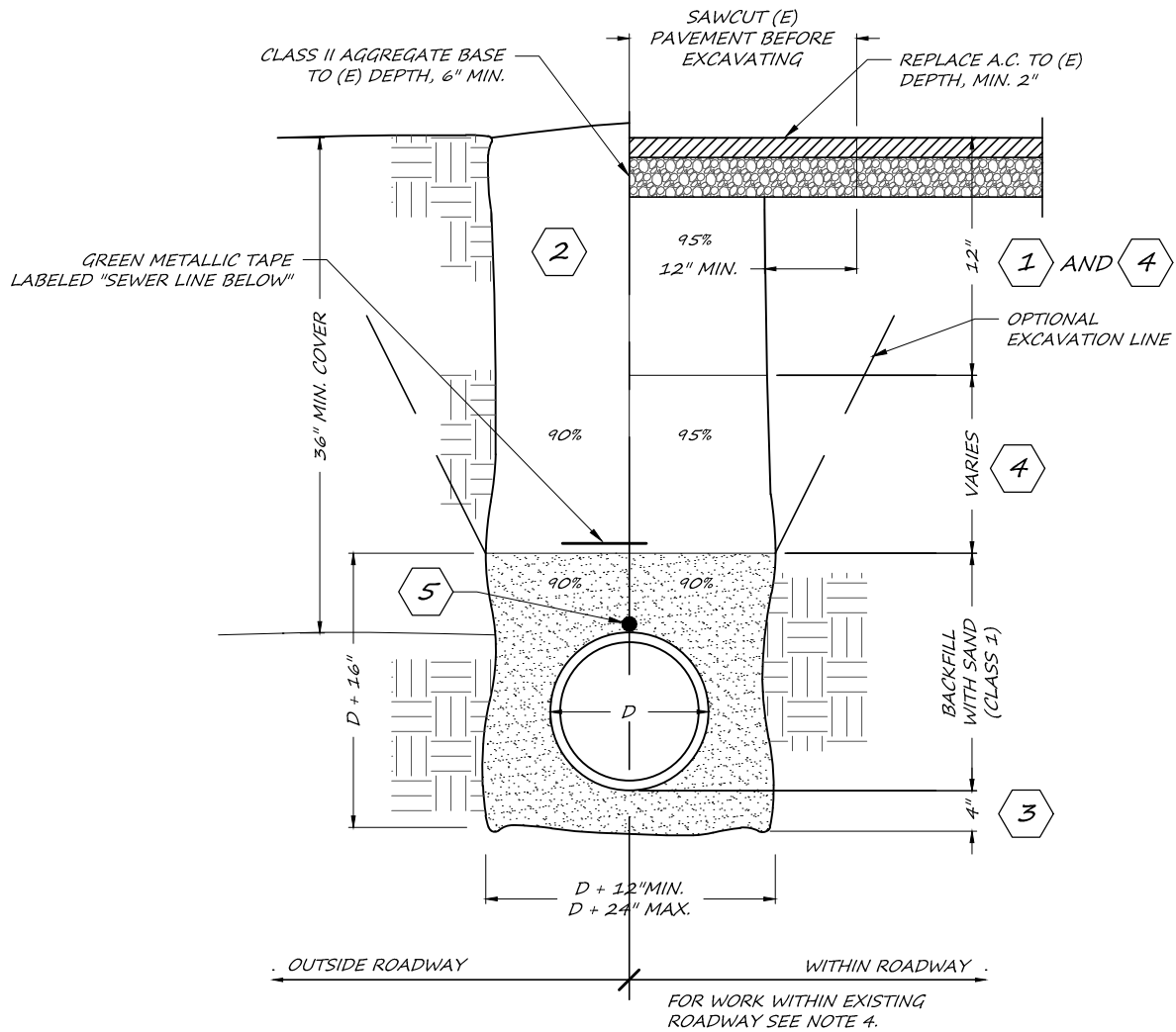

NOTES :

1. TOP BACKFILL SHALL BE IN ACCORDANCE WITH "SPEC. 19-5" STATE OF CALIF STD. SPECS.
2. INTERMEDIATE BACKFILL (CLASS III) MAY BE FROM NATIVE MATERIAL, NO ROCKS LARGER THAN 3'. SCREEN INSIDE ROADWAY, HAND PICK OUTSIDE ROADWAY. (MAY BE EXTENDED TO SURFACE OUTSIDE ROADWAY STRUCTURAL SECTION)
3. EXCAVATE 4" BELOW PIPE AND BACKFILL WITH SAND.
4. IN EXISTING ROADWAYS, TOP AND INTERMEDIATE BACKFILL SHALL BE 2 SACK CONCRETE SLURRY (CLASS IV) IF MIN. COVER IS LESS THAN 36". IF COVER EXCEEDS 36" REMAINDER OF BACKFILL ABOVE SAND SHALL BE AGGREGATE BASE (CLASS II)
5. PROVIDE LOCATOR WIRE NO. 10 AWG COATED SOFT DRAWN COPPER WIRE. TAPE TO PIPE EVERY 10 FEET.

CITY OF SUTTER CREEK

TRENCH DETAIL

			SS
			4
REV No.:	DATE:	BY:	

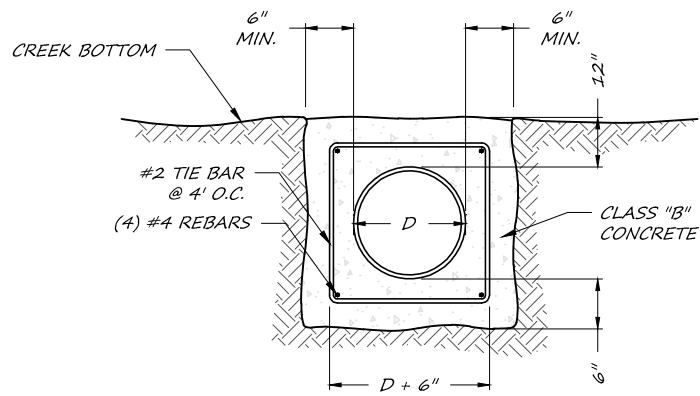

NOTES:

PROVIDE FLEXIBLE CONNECTION AT EACH END OF ENCASEMENT TO PROVIDE FOR SETTLEMENT.

CONTRACTOR TO PROVIDE CONNECTOR SUBMITTAL FOR APPROVAL PRIOR TO PURCHASE.

CITY OF SUTTER CREEK

MINIMUM COVERAGE SECTION

			SS
			5
REV No.:	DATE:	BY:	

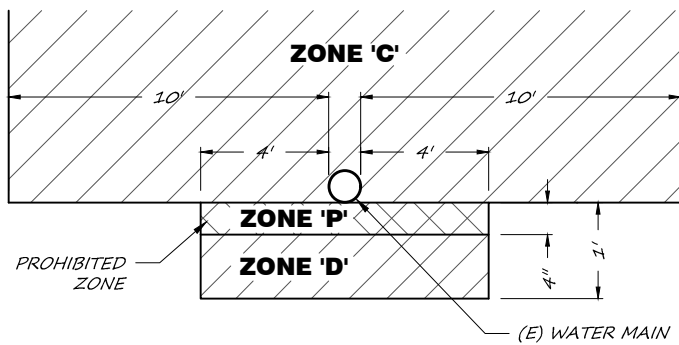

NOTES :

IF A SEWER LINE CROSSES A WATER MAIN IN ZONE 'C' OR 'D', THE SEWER LINE SHALL BE DUCTILE IRON PIPE CI. 50, COMPRESSION JOINT, OR PVC CI. 200 (4:1 SAFETY FACTOR AS PER AWWA SPEC. C-900) WITH RUBBER GASKET JOINT, WITHIN 10 FEET OF WATER MAIN.

CITY OF SUTTER CREEK WATER MAIN CROSSING DETAIL				SS
				6
	REV No.:	DATE:	BY:	

NOTES:

1. ALL CONSTRUCTION SHALL CONFORM TO THESE PLANS AND CALTRANS STANDARD SPECIFICATIONS (MOST CURRENT EDITION) AND TO THE STANDARD SPECIFICATIONS OF THE CITY OF SUTTER CREEK.
2. THE CONTRACTOR SHALL NOTIFY THE CITY 48 HOURS BEFORE STARTING CONSTRUCTION.
3. ALL SEWER SYSTEM CONSTRUCTION SHALL CONFORM TO THE CITY OF SUTTER CREEK SPECIFICATIONS AND STANDARD DETAILS.
4. ALL SEWER SERVICES SHALL HAVE A MINIMUM OF THREE (3) FEET OF COVER AT THE PROPERTY LINE AND TERMINATE AT THE PROPERTY LINE WITH PLUG AND CLEANOUT, AS PER THE CITY STANDARD.
5. A MINIMUM OF 36" COVER BELOW FINISH GRADE FOR SEWER LINE.
6. ALL GRAVITY SEWER PIPE SHALL BE ASTM D-3034, SDR-35, PVC UNLESS REQUIRED TO BE CL200 AWWA C900 AT WATER MAIN CROSSINGS. ALL PRESSURE SEWER PIPE SHALL BE PVC CLASS 200, UNLESS OTHERWISE APPROVED. IF AWWA C900 PIPE IS USED, THE PIPE SHALL BE COLORED GREEN OR A GREEN STRIPE SHALL BE PAINTED ALONG THE TOP OF THE PIPE ALONG ITS ENTIRE LENGTH.
7. CONTRACTOR SHALL BE RESPONSIBLE FOR THE LOCATING AND PROTECTING OF ALL UNDERGROUND FACILITIES AFFECTED BY THE WORK AND SHALL CONTACT UNDERGROUND SERVICES ALERT (USA) 48 HOURS PRIOR TO ANY EXCAVATION WORK FOR DETERMINATION AND LOCATION OF UNDERGROUND UTILITIES (PHONE 800-227-2600).
8. WHERE EXCAVATION FOR ANY FACILITIES CONSTRUCTION EXCEEDS 5 FEET IN DEPTH, CONTRACTOR SHALL OBTAIN AN EXCAVATION PERMIT FROM CAL/OSHA.
9. ALL SEWER SERVICES TO BE 4" INSIDE DIAMETER UNLESS OTHERWISE NOTED.
10. SERVICES SHALL HAVE SAME BEDDING AND BACKFILL AS LATERAL SEWER.
11. SERVICE SEWER SHALL HAVE MINIMUM 3'-0" COVER AT PROPERTY LINE WHENEVER LATERAL DEPTH AND SERVICE SEWER SLOPE OF 1/4" PER FOOT PERMITS. CONTRACTOR SHALL VERIFY THE DEPTH OF ALL SEWER SERVICES AND SHALL NOTIFY THE ENGINEER IF ANY SERVICES CANNOT HAVE THE REQUIRED MINIMUM COVER PRIOR TO INSTALLATION. ALL WATER AND SEWER LINES SHALL MAINTAIN A 10'-0" HORIZONTAL CLEARANCE AND A 1'-0" VERTICAL CLEARANCE.
12. AT SERVICES, PLACE CONCRETE 12" WIDE OR WELL COMPACTED BEDDING MATERIAL 18" WIDE UNDER THE WYE BRANCH, THE FITTING, AND UNSUPPORTED PIPE. WHEN BEDDING MATERIAL IS USED, PLACE ADDITIONAL BEDDING MATERIAL TO TOP OF BEND, THE FULL WIDTH OF THE TRENCH.
13. MINIMUM COVER 3'-0" AT THE PROPERTY LINE SHALL BE MEASURED FROM THE EXISTING GROUND SURFACE OR EDGE OF ADJACENT ROADWAY, WHICHEVER IS LOWER.
14. ALL MANHOLE BARREL SECTIONS, K CONES, AND GRADE RISING SHALL BE REINFORCED IN ACCORDANCE WITH THE REQUIREMENTS OF THE REINFORCED CONCRETE SECTION, A.S.T.M. DESIG. C 478-75.
15. PREFORMED, ROPE-LIKE, READY TO USE, COLD-APPLIED, PERMANENTLY ADHESIVE AND FLEXIBLE, PLASTIC JOINT SEALING COMPOUND, (K.T. SNYDER CO. INC., RAM-NEK) OR EQUAL SHALL BE USED ON MANHOLE JOINTS.
16. ALL SEWER MAINS AND SEWER LATERALS SHALL BE BALLED, MANDRELLED, TELEVISION INSPECTED AND AIR TESTED PRIOR TO ACCEPTANCE BY THE CITY. SEE CITY STANDARD FOR AIR TESTING REQUIREMENTS
17. ALL MANHOLES SHALL BE VACUUM TESTED PRIOR TO ACCEPTANCE BY THE CITY. SEE CITY STANDARD SPECIFICATION FOR VACUUM TESTING REQUIREMENTS.
18. ALL MANHOLE LIDS SHALL HAVE BLIND HOLES FOR LIFTING. PICK HOLES WILL NOT BE ALLOWED. ALL MANHOLES SHALL BE GASKETED USING FLAT GASKETS. "O" RINGS WILL NOT BE ALLOWED.
19. SEWER LINE INSTALLATIONS ON A RADIUS SHALL BE ACCOMPLISHED BY BENDING PIPE ON A RADIUS NOT LESS THAN MANUFACTURER'S MINIMUM RADIUS OR BY USING FITTINGS. AXIAL DEFLECTIONS AT PIPE JOINTS WILL NOT BE ALLOWED.
20. MANHOLE LIDS SHALL BE SIZED AS FOLLOWS: 4' DIA. MANHOLE = 2' DIA. LID, 5' DIA. MANHOLE = 2' DIA. LID, AND 6' DIA. MANHOLE = 2' DIA. LID.
21. AT DEEP DROP SERVICE LINES AT MANHOLES, PROVIDE PVC COUPLING WITH STAINLESS STEEL STRAPS AND STAINLESS STEEL ANCHORS WITHIN 6" OF THE TOP AND BOTTOM AND 4'-0" ON CENTER MAXIMUM SPACING.

CITY OF SUTTER CREEK

SEWER NOTES

SS

7

REV No.:

DATE:

BY: