

Amador Regional Sanitation Authority



“Servicing Amador City, Martell, & Sutter Creek”

August 8, 2025

John J. Baum, P.E.
Assistant Executive Officer
Central Valley Regional Water Quality Control Board
11020 Sun Center Drive #200
Rancho Cordova, CA 95670
John.Baum@waterboards.ca.gov

Subject: Combined Water Balance for the California Department of Corrections and Rehabilitation, Castle Oaks Water Reclamation Facility, Amador Regional Sanitation Authority, and City of Ione

Dear Mr. Baum:

On behalf of the Amador Regional Sanitation Authority (ARSA) I am pleased to submit the Combined Water Balance Technical Memorandum dated August 8, 2025. This Technical Memorandum and supporting documentation have been prepared to satisfy the requirements of the Water Code Section 13267 Order issued on August 14, 2024. The Water Code Section 13267 Order requires dischargers permitted under the Water Reclamation Requirement Order 93-240, including California Department of Corrections and Rehabilitation (CDCR) Mule Creek State Prison (MCSP), ARSA, the City of Ione, and Portlock International LTD, to submit a combined water balance by May 1, 2024. The May 9, 2025, letter of review and concurrence from the Central Valley Regional Water Quality Control Board (Regional Board) provided notice that the submittal date for the combined water balance was extended to August 11, 2025.

The enclosed Technical Memorandum contains the analysis of the combined system including effluent discharges from the Sutter Creek WWTP and MCSP WWTP, operation of the Henderson Reservoir and Preston Reservoir storage facilities, and operations of the Castle Oaks Water Reclamation Facility treatment system and the disposal operations of effluent at the Castle Oaks Golf Course as managed and operated by the City of Ione and Portlock International LTD.

On February 3, 2025, the SWRCB issued a comment letter to ARSA, the City, and Portlock International requiring revisions to the individual water balance submitted pursuant to a separate Water Code Section 13267 Order. The respective Agencies all submitted their revised individual water balance calculations to the SWRCB by February 24, 2025.

Response to SWRCB Letter of Review and Concurrence for ARSA Revised Individual Water Balance, dated May 9, 2025

As a related matter to the combined water balance and in response to the submittal of the ARSA individual water balance on February 24, 2025, the SWRCB provided a letter of review and concurrence with the revised individual water balance calculations on May 9, 2025. The review letter required clarification or additional documentation for the following items, to which our responses are included below:

1. *Clarification from ARSA was requested on how the Sutter Creek Inflow and Infiltration information included the unaccounted for volume of water mentioned in Finding 14 of Cleanup and Abatement Order R5-2017-0708 was considered or included in the ARSA water balance calculations.* Response: As mentioned in the September 2017 ARSA Conveyance, Storage, and Disposal Capacity Report previously submitted to the SWRCB, the actual 2015/2016 flows to Preston Reservoir were overestimated by approximately 35%, and therefore the accuracy of the unaccounted for volume mentioned in Order R5-2017-0708 is highly uncertain. The recent water balances have utilized the best available information for the most recent 5-years including daily flows, monthly facilities status reports for storage reservoirs, and staff reports. No recent data appears to conflict with the information utilized for the updated ARSA water balances.
2. *The City of Ione and COGC are required to prepare and submit a plan detailing the steps and practices that will be implemented with respect to Lake I operations to ensure no unauthorized discharge to Mule Creek occur in the future.* Response: This plan is provided by the City of Ione and COGC separate from this memo.
3. *If ARSA intends to continue land application on Bower's Ranch, Hoskin's Ranch, or the proposed Noble Ranch, ARSA is required to submit signed Form 200s from each landowner along with a Report of Waste Discharge and/or Title 22 Engineering Report demonstrating compliance with the Central Valley Water Board's Basin Plan.* Response: These forms and reports will be prepared by ARSA and submitted to the SWRCB as part of the planned permit update process.

All data for the combined water balance have been reviewed and approved by the respective management personnel of each responsible party. Each Agency will provide certification of the document(s) under separate cover letters. As the General Manager of ARSA, I have reviewed the contents of the Technical Memorandum and provide the following certification of its basis and findings:

Amador Regional Sanitation Authority



"Servicing Amador City, Martell, & Sutter Creek"

I certify under penalty of law that I have personally examined and am familiar with the information submitted in this document and all attachments and that, based on my inquiry of those individuals immediately responsible for obtaining the information, I believe that the information is true, accurate, and complete. I am aware that there are significant penalties for submitting false information, including the possibility of fine and imprisonment.

Sincerely,

A handwritten signature in cursive script that reads "Tom Dubois".

Tom Dubois
General Manager
Amador Regional Sanitation Authority

CC:

Kari Holmes, PE, Supervising Water Resources Control Engineer Compliance and Enforcement Program, CVRWQCB
Howard Hold, Senior Engineering Geologist, WDRs and Title 27 Compliance and Enforcement Unit, CVRWQCB
Scott Armstrong, CVRWQCB, Rancho Cordova
George Lee, City of Ione
Dan Griffin, Castle Oaks Golf Club
Frank Hahn, Portlock International LTD.
Gregor Larabee, California Department of Corrections, Sacramento
Gary Ghio, Weber, Ghio, and Associates, Inc.
Bill Slenter, HydroScience Engineers, Inc.



**City of Ione
P.O. Box 398
1 E. Main Street
Ione, CA 95640**

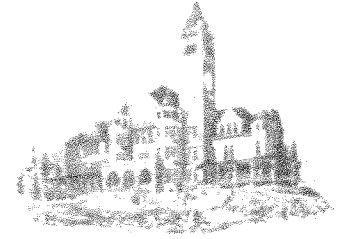

August 7, 2025

John J. Baum, P.E.
Assistant Executive Officer
Central Valley Regional Water Quality Control Board
11020 Sun Center Drive #200
Rancho Cordova, CA 95670
John.Baum@waterboards.ca.gov

Subject: Certification Letter for Combined Water Balance for the California Department of Corrections and Rehabilitation, Castle Oaks Water Reclamation Facility, Amador Regional Sanitation Authority, and City of Ione

Dear Mr. Baum,

On August 14, 2024, the Central Valley Water Quality Control Board (Regional Board) issued a 13267 Order letter to the City of Ione (City), the Jackson Rancheria Development Corporation, Amador Regional Sanitation Agency (ARSA), Portlock International Ltd. (Portlock), the California Department of Corrections and Rehabilitation (CDCR) Mule Creek State Prison, and the California Department of Forestry Fire Academy. These entities are permitted by the Regional Board under the following orders:

- Water Reclamation Requirement (WRR) Order 93-240 (1993 WRRS), which permits discharges within the ARSA system, the Ione Castle Oaks Water Reclamation Facility (COWRF), and discharge to the land application areas on Castle Oaks Golf Course (COGC);
- Waste Discharge Requirements (WDRs) R5-2013-0022-001 (Ione WWTF WDRs), which permits the City of Ione's Wastewater Treatment Facility and the discharges to land application areas owned by the City of Ione and the Jackson Rancheria Development Corporation; and

- WDRs Order R5-2015-0129 (MCSP WDRs), which permits the Mule Creek State Prison treatment facility and associated land application areas.

The 13267 Order requires that by May 1, 2024 the named permittees submit a combined water balance that accounts for the inflow, storage, treatment, and disposal capacity for the entire interconnected system. A May 9, 2025 letter from the Regional Board provided notice that the submittal date for the combined water balance was extended to August 11, 2025.

In February 2025, the City of Lone submitted an individual water balance for the City of Lone's Wastewater Treatment Facility. The City's facility does not discharge to the combined system and flows from the combined system into the City of Lone's facility were accounted for in the City's individual water balance submitted in February 2025 and approved by the Regional Board in May 2025. Therefore, the preparation of a combined water balance does not impact the City of Lone's previously submitted information. Consequently, ARSA led the development of the combined water balance required under the 13267 Order.

The August 13267 Order states that a cover letter for the water balance submittal be signed by the appropriate representatives (i.e. owners) for each party that includes a certification statement. The City of Lone's City Manager and our consultant team have participated in the development of the combined water balance. The City Manager believes appropriate due diligence was applied in development of the combined water balance and provides the following certification statement as it pertains to the COWRF, the COGC, and the City's Wastewater Treatment Facility:

I certify under penalty of law that I have personally examined and am familiar with the information submitted in this document and all attachments and that, based on my inquiry of those individuals immediately responsible for obtaining the information, I believe that the information is true, accurate, and complete. I am aware that there are significant penalties for submitting false information, including the possibility of fine and imprisonment.

Sincerely,

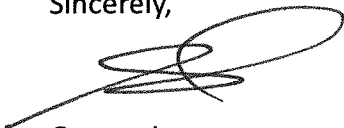

George Lee
City Manager
City of Lone

CC:

Kari Holmes, PE, Supervising Water Resources Control Engineer Compliance and Enforcement Program, CVRWQCB

Howard Hold, Senior Engineering Geologist, WDRs and Title 27 Compliance and Enforcement Unit, CVRWQCB

Scott Armstrong, CVRWQCB, Rancho Cordova

Tom Dubois, ARSA

Gregor Larabee, California Department of Corrections, Sacramento

MULE CREEK STATE PRISON

4001 Highway 104
Ione, CA 95640



August 8, 2025

John J. Baum, Assistant Executive Officer
Central Valley Regional Water Quality Control Board
11020 Sun Center Drive, #200
Rancho Cordova, CA 95670

Dear Mr. Baum,

Mule Creek State Prison has cooperated with the City of Ione and the Amador Regional Sanitation Authority to develop the enclosed combined water balance as required by the August 14, 2024 Water Code 13267 Order.

I certify under penalty of law that I have personally examined and am familiar with the information submitted in this document and all attachments and that, based on my inquiry of those individuals immediately responsible for obtaining the information, I believe that the information is true, accurate, and complete. I am aware that there are significant penalties for submitting false information, including the possibility of fine and imprisonment.

Sincerely,

A handwritten signature in black ink, appearing to be "Luis Garnica".

LUIS GARNICA
Warden

Enclosure

cc: Isolette Gunther, Facility Planning, Construction and Management, CDCR
Gregor Larabee, Facility Planning, Construction and Management, CDCR
Laurie Perri, Facility Planning Construction and Management, CDCR
Eric Papathakis, Office of Legal Affairs, CDCR
George Lee, City of Ione
Tom DuBois, Amador Regional Sanitation Authority
James Swift, Amador Regional Sanitation Authority
Catherine Frazer, California Department of Forestry and Fire Protection
Crystal Jack, Jackson Rancheria Development Corporation

Technical Memorandum

To: Tom DuBois, General Manager, Amador Regional Sanitation Authority
George Lee, City Manager, City of Ione
Gregor Larabee, Chief of Environmental and Regulatory Compliance Section,
CDCR

From: HydroScience Engineers, Inc.

Prepared By: Steven Whittlesey, PE

Reviewed By: Bill Slenter, PE

Subject: Amador Regional Sanitation Authority, City of Ione,
and Mule Creek State Prison Combined Water Balance Update

Date: August 8, 2025



This Technical Memorandum (TM) provides the results of combined water balance calculations that have been prepared in response to the August 14, 2024, Central Valley Regional Water Quality Control Board (Water Board) Water Code Section 13267 Order for Technical Report, Mule Creek State Prison (MCSP), California Department of Corrections and Rehabilitation (CDCR)/California Department of Forestry and Fire Protection (CalFire); Amador County Regional Outfall and Castle Oaks Golf Course and Development (COGC), City of Ione / Amador Regional Sanitation Authority (ARSA)/Portlock int. LTD; Ione Wastewater Treatment Facility, City of Ione (City) / Jackson Rancheria Development Corporation, Amador County. The calculations for this combined water balance utilize the previous data submitted to the Water Board for the City of Ione individual water balance for the City of Ione Wastewater Treatment Facility (WWTF), MCSP individual water balance, the ARSA individual water balance, and the disposal system in joint operation with the Castle Oaks Water Reclamation Facility (COWRF) and the COGC which receive secondary disinfected effluent from the MCSP and Sutter Creek Wastewater Treatment Plants (WWTPs). This TM is organized into the following sections:

- Background Information
- Basis of Water Balance Calculations
- Results of Water Balance Calculations

Background Information

The ARSA, City, and Portlock International Ltd. (Portlock) are all permittees under the State Water Resources Control Board (SWRCB) Water Reclamation Requirement Order 93-240 (WRRs). The WRRs permit the Henderson and Preston Reservoirs system, the COWRF, and the COGC land application areas (LAAs). ARSA operates the storage and disposal facilities downstream of the Sutter Creek WWTP, however the City operates the COWRF and Portlock operates the COGC.

The system includes conveyance infrastructure, three storage reservoirs and two LAAs. The system receives secondary disinfected effluent from the Sutter Creek WWTP and disposes of it on the Bower's Ranch and Hoskin's Ranch LAAs. Storage is provided in the system by the Henderson Reservoir, Preston Forebay and Preston Reservoir. Remaining effluent that is not disposed in the system is conveyed to the COWRF to receive tertiary treatment before it is disposed at the COGC. ARSA also owns a diversion from Sutter Creek that may divert surface

water to meet irrigation demands when inadequate volume of effluent is available. The Sutter Creek diversion is in need of repair and ARSA continues to seek cost effective bids for the work.

The MCSP WWTP receives wastewater from the Preston Youth Correctional Facility (PYCF), the CalFire Training Academy (CFTA), the Mule Creek Infill Complex (MCIC), and the MCSP. Effluent from the MCSP WWTP is treated to disinfected secondary standards and is discharged to six LAAs encompassing 200 acres. MCSP WWTP effluent is also discharged to the COWRF to a maximum of 350 acre-feet per year. The flow diagram from wastewater generating sources to the MCSP WWTP are shown in Figure 1. Discharges from the MCSP WWTP are shown schematically in Figure 2.

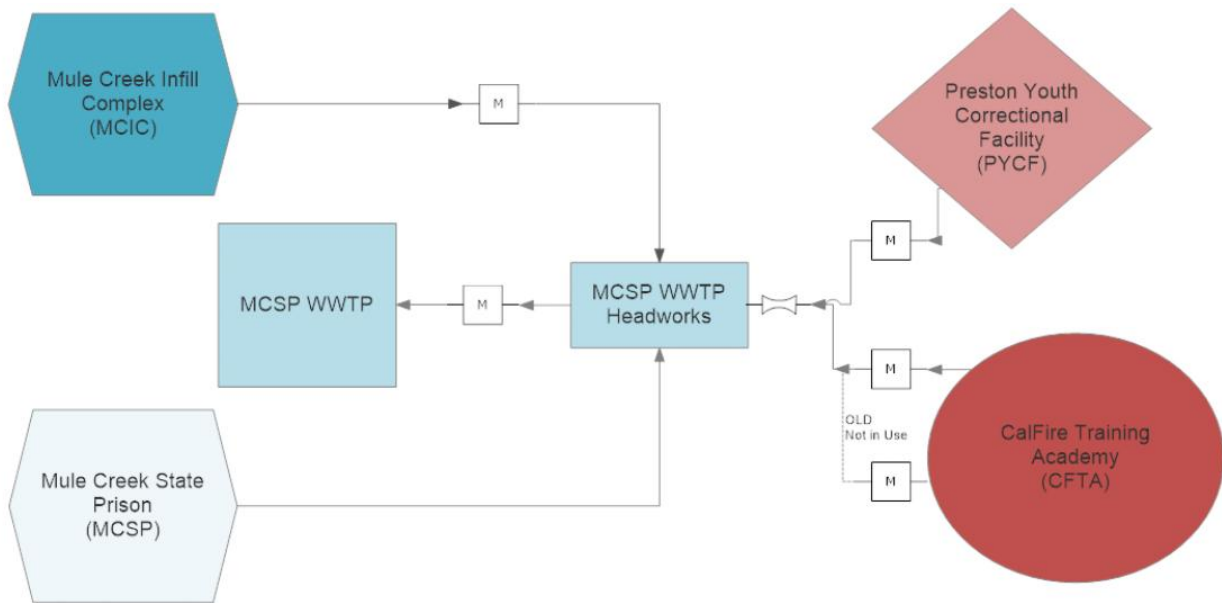

Figure 1: MCSP WWTP Collection System Flow Diagram

Source: MCSP Individual Water Balance TM, KSN Engineers, Revised February 24, 2025

Under a 2007 contractual agreement (Tri-Party Agreement) with the City, the MCSP has sent effluent to the COWRF either through Preston Reservoir or directly via a bypass line. The discharge from MCSP to the COWRF is not described in the WRRs and is an agreement between ARSA, the City, and the CDCR. This agreement is the Parties' effort to manage the system to the maximum benefit possible. The flow diagram of the interconnected system is illustrated in Figure 2.

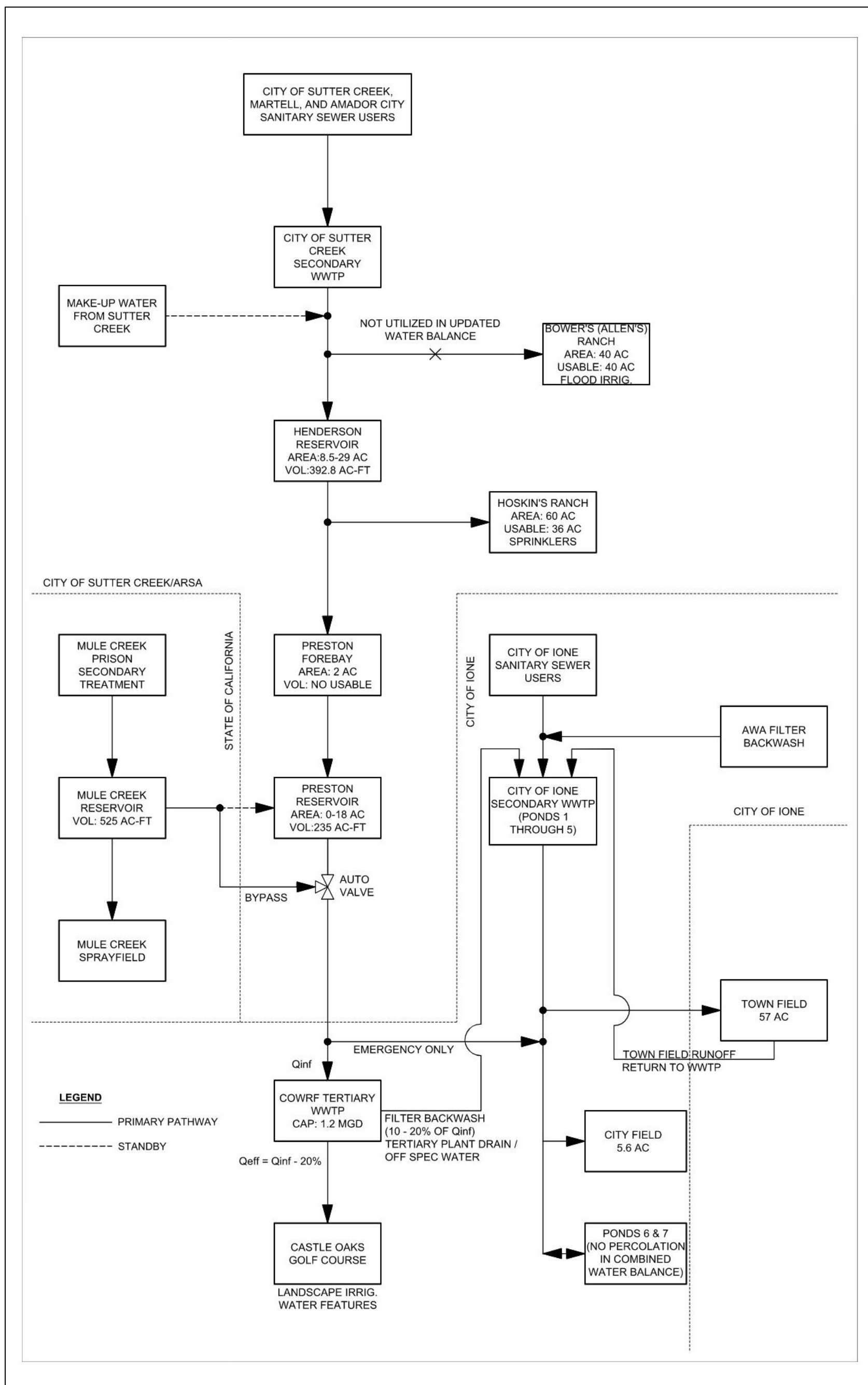

Figure 2: Combined Storage and Disposal System Flow Diagram

On August 14, 2024, the SWRCB issued a Water Code Section 13267 Order to CDCR, CalFire, ARSA, the City, Jackson Rancheria Development Corporation, and Portlock International Ltd., requiring a statement signed by all parties stating if they intended to cooperate on a combined water balance based on the individual facility water balances. The parties coordinated joint responses sent to the SWRCB on or before February 1, 2025, that affirmed the intent to prepare a combined water balance. On May 9, 2025, the SWRCB issued a letter of review and concurrence with the individual water balance which required additional analysis and clarifications specific to each Agencies' individual water balances. The letter of review and concurrence also revised the due date for the combined water balance to August 11, 2025.

This TM includes the combined water balance for the combined Henderson/Preston/COWRF/COGC system (Combined System) including effluent from all parties and incorporates the forecasted flows, facilities, and projected operations over the next 5 years.

The following documents are referenced as sources of information on each Agencies' projected flows and operations over the next 5 years, but are not included as attachments to this memorandum due to file size and redundancy as they have already been received by the SWRCB:

- Technical Memorandum - Revised ARSA Water Balance Update, February 2025, by HydroScience Engineers, Inc.
- Certification Letter for Castle Oaks Golf Course Recycled Water Demands, February 2025 (dated February 26, 2024), by City of Lone
- Technical Memorandum - Updated Water Balance for City of Lone Wastewater Treatment Facility, WDR Order R5-2013-0022-001, February 2025 (dated February 26, 2024), by West Yost Associates, Inc.
- Technical Memorandum - Castle Oaks Water Reclamation Facility Capacity and Operations Summary, December 2024, by West Yost Associates, Inc.
- Technical Memorandum - Castle Oaks Golf Course Recycled Water Demands, December 2024, by West Yost Associates, Inc.
- Technical Memorandum – Mule Creek State Prison Individual Water Balance, Revised February 24, 2025, by KSN, Inc.

Basis of Water Balance Calculations

This section summarizes the sources of historical flows, facilities operations, and climatological data used to complete the combined water balance calculations. The combined water balance calculations address effluent from ARSA and MCSP, storage at Henderson and Preston Reservoirs, treatment at COWRF, and application at COGC and the ARSA LAAs, and do not include effluent from the City of Lone WWTF.

Existing wastewater flows to the Sutter Creek WWTP, and wastewater flows and operations of the Combined System over the next 5 years are based on the information provided in the ARSA Revised Individual Water Balance TM submitted to the SWRCB on February 24, 2025. As mentioned in the ARSA Revised Individual Water Balance TM, the precipitation distribution pattern from the 2016/2017 water year results in a higher storage requirement due to higher precipitation during the winter when no disposal is occurring. Therefore, the combined water balance calculations for this TM are based on the 2016/2017 precipitation distribution.

Changes to ARSA's water balance to characterize the combined water balance include the estimated export volumes from MCSP into the Combined System. Current MCSP practice is to discharge via the bypass line, directly to COWRF. This water balance assumes MCSP discharge to Preston Reservoir in acknowledgement of this option. MCSP discharge to Preston Reservoir during the irrigation season as opposed to direct discharge to COWRF does not significantly impact this water balance.

Discharge volumes to the Preston Reservoir or COWRF from MCSP WWTP are based on the population and flow projections, operations, and climatological factors in the MCSP Individual Water Balance TM submitted to the SWRCB on February 24, 2025. Included as Attachment B is a summary of the required discharge volumes to the COWRF to maintain storage capacity and disposal operations in compliance with their Waste Discharge Requirements. Under the individual water balance, MCSP was requested to analyze 0.54, 0.67 and 0.74 MGD Average Dry Weather Flow (ADWF) in their water balance, however with input from Regional Water Quality Control Board staff, the projections were revised to consist of only the 0.54 and 0.67 MGD basis for the Combined Water Balance. These two scenarios were also analyzed in the combined water balance calculations of this TM. The required minimum discharge volumes from the MCSP WWTP are presented in Table 1.

During the 100-year return period (RP100) water year, the 0.54 MGD ADWF scenario requires 27.6 acre-feet to be discharged over the months of May through September. The 0.67 MGD ADWF scenario requires 31.9 acre-feet discharged throughout November through May, and 221.6 acre-feet throughout June through September in the RP100 water year for a total of 253.5 acre-feet. Each of these discharges were averaged by dividing their volumes by the number of months they are discharged into Preston Reservoir.

Table 1: MCSP WWTP Discharges to Preston Reservoir for RP100 and Average Water Years

Month	2030 MCSP WWTP Discharges to Preston Reservoir			
	0.54 MGD ADWF		0.67 MGD ADWF	
	RP100 WY (Ac-ft)	Avg WY (Ac-ft)	RP100 WY (Ac-ft)	Avg WY (Ac-ft)
October	0.0	0.0	0.0	0.0
November	0.0	0.0	4.56	0.0
December	0.0	0.0	4.56	0.0
January	0.0	0.0	4.56	0.0
February	0.0	0.0	4.56	0.0
March	0.0	0.0	4.56	0.0
April	0.0	0.0	4.56	0.0
May	5.52	0.0	4.56	0.0
June	5.52	0.0	55.4	0.0
July	5.52	0.0	55.4	0.0
August	5.52	0.0	55.4	0.0
September	5.52	0.0	55.4	0.0
Total	27.60	0.00	253.52	0.00

Preston Reservoir has an existing usable storage capacity of approximately 235 acre-feet while maintaining a minimum 2-feet of freeboard. As described in the COWRF Title 22 Engineers Report prepared by West Yost Associates, the Preston Reservoir storage capacity is reduced to create an emergency buffer for potential shutdown of the COWRF. Emergency storage volumes are required to be 20 days of the COGC irrigation demands. The required emergency storage volume varies from month to month depending on the evapotranspiration potential at the COGC. During high evapotranspiration months such as July, when COGC irrigation demands reach their peak, the required emergency storage volume will also be greater. The emergency storage volumes and resulting usable Preston Reservoir storage volumes are presented in Table 2.

Table 2: COWRF and COGC Demands and Preston Reservoir Storage Capacities

Month	RP100 WY			Avg WY		
	COWRF + COGC Demands (Ac-ft)	Emergency 20-d Storage Required (Ac-ft)	Preston Reservoir Usable Capacity (Ac-ft)	COWRF + COGC Demands (Ac-ft)	Emergency 20-d Storage Required (Ac-ft)	Preston Reservoir Usable Capacity (Ac-ft)
October	11.3	8	227	27.3	18	217
November	0.0	0	235	0.0	0	235
December	0.0	0	235	0.0	0	235
January	0.0	0	235	0.0	0	235
February	0.0	0	235	0.0	0	235
March	0.0	0	235	0.0	0	235
April	11.9	8	227	35.3	24	211
May	61.7	40	195	70.1	46	189
June	89.4	60	175	92.4	62	173
July	99.9	64	171	100.9	66	169
August	89.4	58	177	91.1	58	177
September	59.9	40	195	64.6	44	191
Total	423.5	--	--	481.7	--	--

Basis of City of Lone Excess Effluent Volumes

As shown in Figure 2, the City of Lone WWTF receives backwash flow from the COGC. The COGC backwash flows are proportional to the amount of effluent treated at the COWRF, and therefore the excess effluent flows estimated for the City of Lone’s WWTF are also affected by the COGC backwash flows to a certain extent. The basis of the excess effluent volumes for the City of Lone WWTF are discussed in this section.

On February 3, 2025, the Water Board issued a letter titled Review of Site Specific Water Balance to the City of Lone that identified the use of Ponds 6 and/or 7 for percolation as being inconsistent with the requirements of the Lone WWTF WDRs or Cease and Desist Order (CDO) R5-2014-0157, which required the lining or closure of the ponds. The City of Lone was required to prepare a revised water balance dated February 26, 2025, that reflected the Lone WWTF without percolation disposal from Ponds 6 and 7. Without percolation from Ponds 6 and 7, the City’s facilities were undersized to store and dispose of the effluent. It was assumed that both Ponds 6 and 7 are emptied in October to another storage location which was not yet defined.

Excess effluent volume projections from the City of Lone’s WWTF are separate from the Henderson Reservoir, Preston Reservoir, and COWRF/COGC system, and are based on the City’s projected 2030 ADWF of 0.65 MGD. The monthly excess effluent volumes summarized in Table 3 are taken from the water balance model results for the City’s February 2025 water balance analysis specifically Column 49 for “Discharge/Store Elsewhere” values. The City provided documentation and summary of their water balance results, which is included in Attachment A.

Table 3: Lone WWTF Excess Effluent Volumes for RP100 and Average Water Years

Month	2030 Lone WWTF Excess Effluent Volumes	
	0.65 MGD ADWF	
	RP100 WY (Ac-ft)	Avg WY (Ac-ft)
October	97.9	94.5
November	19.8	8.9
December	92.1	60.8
January	116.1	62.8
February	67.0	49.9
March	62.3	53.1
April	47.0	41.8
May	41.3	39.9
June	42.9	41.7
July	38.2	38.2
August	33.8	33.8
September	38.6	39.4
Total	697.0	564.8

Combined System Water Balance Results

This section discusses water balance calculations for the Combined System that were completed for calibrated future flow conditions. All water balance calculations consist of evaluation of system operations during a RP100 WY followed by an average year WY.

The assumptions of the water balance calculations incorporate the following logic:

- 1) Fully meet all irrigation demands at the LAAs utilizing effluent to the maximum agronomic rate for each given month.
- 2) Henderson Reservoir is assumed to maintain a minimum dead pool of 27.5 Ac-ft at 5 ft stage, whereas Preston Reservoir is allowed to reach 0 Ac-ft storage (empty).
- 3) MCSP discharges into the Henderson/Preston System are only to Preston Reservoir or via the bypass line, and not into any upstream facilities..
- 4) Any excess of Sutter Creek WWTP effluent or precipitation / runoff not used to meet irrigation demands is stored in Henderson Reservoir first and then, once it reaches full capacity of 392.8 Ac-ft at 2 ft freeboard, any excess volume is sent to Preston Reservoir. Runoff and precipitation within Henderson Reservoir or its catchment area is retained in it. All other runoff and precipitation in the system in excess of monthly irrigation demand is retained in Preston Reservoir. Evaporation from Preston Reservoir is limited to the evaporation surface area at 235 Ac-ft even when it is shown to exceed its storage capacity. The resulting final storage volumes for the month are then carried over as the beginning storage volume for the following month.
- 5) It is assumed there are zero percolation losses from either Henderson or Preston Reservoirs. This conservative assumption is used because no recent site-specific percolation studies have been completed for the system.

When MCSP ADWF is 0.54 MGD, the excess effluent storage volume (Row I) is approximately 2.1 Ac-ft for the RP100 water year and an additional 8 Ac-ft of effluent outflows (Row O) are needed to empty the Preston Reservoir by the end of the average water year to reach a final system storage of 27.5 Ac-ft at end of September. This 2.1 Ac-ft excess volume is primarily due to the Title 22-required COWRF 20-day emergency effluent storage volume change between June and July. However, the Preston Reservoir would only be at 173.1 Ac-ft of its 235 Ac-ft capacity and the 2.1 Ac-ft excess volume may not actually result in overtopping unless the COWRF were shut down for more than 20 days and ARSA and MCSP continued to convey effluent to Preston Reservoir. Additionally, the 8 Ac-ft of excess effluent volume may be negligible if an actual percolation rate were applied to the water balance. Hypothetically, a percolation rate of 1.92E-03 feet per day, or 6.67E-06 inches per hour, at the Henderson Reservoir, Preston Forebay, and Preston Reservoir would balance the 8 Ac-ft of excess effluent volume.

In the scenario where MCSP ADWF is 0.67 MGD, the excess effluent storage volume (Row I) would be 138.5 Ac-ft in the RP100 water year, and 208.8 Ac-ft in the following average year. Additional effluent outflows (see Row O) of 215.6 Ac-ft would be required to empty Preston Reservoir and return the system to the minimum storage volume of 27.5 Ac-ft by the end of the average water year. The overall water balance results for each scenario are summarized in Table 4. Detailed water balance calculations are provided in Attachment C for further reference.

Table 4: Summary of ARSA/MCSP and COGC System Water Balance Calculation Results

Row Number	Row Calculations	Parameters	Water Balance Scenario Results			
			Scenario 1		Scenario 2	
			Future Flows MCSP 0.54 MGD ADWF		Future Flows MCSP 0.67 MGD ADWF	
			Climate Conditions	RP100 (Year 1)	Avg Year (Year 2)	RP100 (Year 1)
Inflow Results						
A	--	Sutter Creek WWTP Effluent (Ac-ft)	537.4	465.0	537.4	465.0
B	--	MCSP WWTP Effluent (Ac-ft)	27.6	0.0	253.5	0.0
C	--	Precipitation and Runoff (Ac-ft)	230.6	120.1	230.6	120.1
Storage Facilities Results						
D	--	Henderson Reservoir Max Storage Volume (Ac-ft)	392.8	300.4	392.8	300.4
E	--	Preston Reservoir Max Storage Volume (Ac-ft)	175.2	171.7	333.5	389.4
F	--	Henderson Reservoir Evaporation (Ac-ft)	73.8	60.2	73.8	60.2
G	--	Preston Forebay Evaporation (Ac-ft)	6.6	7.2	6.6	7.2
H	--	Preston Reservoir Evaporation (Ac-ft)	47.5	50.1	52.9	63.0
I	--	Preston Reservoir Excess Storage Volume (Ac-ft)	2.1	0.0	138.5	209.2
Disposal Results						
J	--	Bower's Ranch Irrigation Demands (Ac-ft)	0.0	0.0	0.0	0.0
K	--	Hoskin's Ranch Irrigation Demands (Ac-ft)	115.5	106.7	115.5	106.7
L	--	COWRF & COGC Irrigation Demands (Ac-ft)	423.4	481.7	423.4	481.7
Overall Calculation Results						
M	(A+B+C)	Total Inflows Excluding Unmet Irrigation Demands (Ac-ft)	795.6	585.1	1021.5	585.1
N	(F+G+H+J+K+L)	Total Outflows (Ac-ft)	666.9	705.9	672.2	718.9
O	-- ⁽²⁾	Combined System Excess Effluent Volume (Ac-ft)	-- ⁽²⁾	8.0	-- ⁽²⁾	215.6
P	(D+E), or as shown ⁽¹⁾	Combined System Maximum Storage Volume Required (Ac-ft)	568.0	472.1	594.8	689.8

(1) The peak month storage volumes for Henderson and Preston Reservoirs may be in different months than the overall system's peak storage month, resulting in discrepancies of between Row S values and (D+E) calculations (see Scenario 2 values). Where discrepancies occur, Row S displays overall peak storage month volumes from water balance calculations.

(2) Emptying Preston Reservoir is not required in the first water year. Volumes are the outflow estimated at the end of the second water year to bring the ARSA final storage volume to the minimum 27.5 Ac-ft minimum pool in Henderson Reservoir.

Summary of Results and Future Considerations

Both the City of Ione WWTF and the Combined System indicate there will be excess effluent volume from both system’s respective water balance calculations. A summary of the excess effluent volumes from each system is provided in Table 5.

Table 5: Summary of Excess Effluent Volumes

Entity / Flow Scenario	Excess Effluent Volume (Ac-ft)
City of Ione (2030 Ione ADWF of 0.65 MGD)	697.0 (RP100 Conditions) 564.8 (Avg Yr Conditions)
Combined System (MCSP ADWF of 0.54 MGD)	2.1 (RP100 Conditions) 8.0 (Avg Yr Conditions)
Combined System (MCSP ADWF of 0.67 MGD)	138.5 (RP100 Conditions) 215.6 (Avg Yr Conditions)

The City of Ione’s excess effluent volume at a projected 2030 ADWF of 0.65 MGD range from 564.8 Ac-ft during average year conditions to 697.0 Ac-ft under RP100 conditions. The City of Ione continues to investigate options to increase the storage and disposal capacity necessary to accommodate existing demands and projected growth. The City is currently seeking grant funding to support the completion of the required Feasibility Study related to this effort. The results of the joint water balance effort will inform Ione’s preparation of the Feasibility Study. Options will also be developed in conjunction with ARSA, CDCR, and/or the Regional Water Quality Control Board.

For the Combined System, the excess effluent volumes vary between RP100 and average water year conditions from approximately 2.1 to 8 Ac-ft at an MCSP ADWF of 0.54 MGD, and from 138.5 to 215.6 Ac-ft at an MCSP ADWF of 0.67 MGD. The combined water balance model consists of a RP100 water year followed by an avg water year. Excess effluent volumes for the avg water year are larger than the RP100 because all remaining effluent in storage must be disposed of by the end of the avg water year. Excess effluent volumes presented are not indicative of volumes from a standalone RP100 or avg water year.

The actual system improvements to accommodate the excess effluent volumes will be defined in future site-specific planning and design phases. As mentioned in CDCR’s individual water balance, the future potential infrastructure changes under consideration for the MCSP system include additional onsite or offsite LAA development.

THIS PAGE INTENTIONALLY LEFT BLANK

ATTACHMENT A
Amador Regional Sanitation Authority
2025 Combined Water Balance

City of Ione Wastewater Flow Information for Combined Water
Balance
TM by West Yost Associates, Inc.

THIS PAGE INTENTIONALLY LEFT BLANK

TECHNICAL MEMORANDUM

DATE: July 8, 2025

Project No.: 988-50-24-10

SENT VIA: EMAIL

TO: George Lee, City Manager, City of Lone
Bill Slenter, Hydrosience Engineers

CC: Justin Granados, WaterStone Services

FROM: Ansley Guillebeau, EIT

REVIEWED BY: Kathryn Gies, PE, RCE #65022

SUBJECT: Information Required for Joint Agency Water Balance



This technical memorandum documents the information from the City of Lone (City) that is required to prepare a joint water balance that includes all wastewater flows that are eventually discharged to the City's Wastewater Treatment Facility (WWTF) and/or to the Castle Oaks Water Reclamation Facility (COWRF). In February 2024, the City completed an updated water balance for the WWTF in response to a 13267 Order letter from the Central Valley Regional Water Quality Control Board (Regional Board). The 13267 Order requires a combined water balance be submitted to the Regional Board by May 1, 2025. This deadline was later extended by the Regional Board to August 11, 2025.

To support the development of the joint water balance, this TM provides water balance model results for the WWTF. In addition, this TM defines the storage requirements of the Amador Regional Sanitation Authority (ARSA) Preston Reservoir, located upstream from the COWRF. This storage is needed to satisfy the COWRF recycled water reliably requirements that are defined in the California Code of Regulations (CCR), Title 22, Division 4, Chapter 3 (Title 22).

WATER BALANCE RESULTS FOR THE WWTF

The water balance model results for the WWTF, which will serve as inputs to the combined water balance, are shown in Table 1. These values are taken from Attachment F of the February 2024 Water Balance Analysis, specifically Column 49 for "Discharge/Store Elsewhere" values in the respective water balance tables. Two separate sets of water balances were included with the prior analysis, based on two different crop coefficients (0.32 and 1.0); the values provided/shown are from water balances based on a crop coefficient of 0.32.

Month	Current Wastewater Flows		Projected Year 2030 Wastewater Flows	
	Average Year Water Balance	1-in-100 Year Water Balance	Average Year Water Balance	1-in-100 Year Water Balance
October	84.5	87.9	94.5	97.9
November	0.0	10.8	8.9	19.8
December	51.8	82.1	60.8	92.1
January	52.8	107.1	62.8	116.1
February	40.9	58.0	49.9	67.0
March	44.1	53.3	53.1	62.3
April	32.8	38.0	41.8	47.0
May	30.9	31.3	39.9	41.3
June	32.7	33.8	41.7	42.9
July	28.2	29.3	38.2	38.2
August	24.7	23.8	33.8	33.8
September	29.4	38.6	39.4	38.6

STORAGE REQUIREMENTS OF THE ARSA PRESTON RESERVOIR

The COWRF produces disinfected tertiary recycled water for irrigation use at the Castle Oaks Golf Club. Title 22 includes reliability requirements, which the COWRF satisfies by providing emergency long-term storage. When long-term storage is used to meet Title 22 reliability requirements, at least 20 days of storage capacity must be provided. For the COWRF, this requirement is met by the ARSA system’s Preston Reservoir, which is located upstream from the COWRF.

In the event of the shutdown of the COWRF, secondary effluent received from either the Mule Creek State Prison (MCSP) Wastewater Treatment Plant (WWTP) or the Sutter Creek WWTP can be directed to and/or stored in the Preston Reservoir until the COWRF can be returned to service. The storage required in each month is defined based on the irrigation demands of the golf course during the irrigation season, as defined in the *Castle Oaks Golf Course Recycled Water Demands Technical Memorandum*, which has been provided separately. The calculated long-term storage needed for the Preston Reservoir is shown in Table 2 for both the average rain year and the 100-year rain year.

Table 2. Long Term Storage Required in ARSA Preston Reservoir						
Month	Average Rainfall Year			1-in-100 Rainfall Year		
	Total Monthly Influent Flow^(a), acre-feet	Daily Average Influent Flow, acre-feet/day	Long-Term Storage Required, acre-feet	100-Year	Daily Average Influent Flow^(b), acre-feet/day	Long-Term Storage Required, acre-feet
April	35.3	1.2	24	11.9	0.4	8
May	70.1	2.3	46	61.7	2.0	40
June	92.4	3.1	62	89.4	3.0	60
July	100.9	3.3	66	99.9	3.2	64
August	91.1	2.9	58	89.4	2.9	58
September	64.6	2.2	44	59.9	2.0	40
October	27.3	0.9	18	11.3	0.4	8

(a) Data provided in Table 9 of the *Castle Oaks Golf Course Recycled Water Demands Technical Memorandum*.
 (b) Data provided in Table 10 of the *Castle Oaks Golf Course Recycled Water Demands Technical Memorandum*.

As part of the efforts to develop the joint water balance, the storage requirements summarized in Table 2 will need to be accounted for. Additionally, the information in Table 2 can be used by MCSP and ARSA staff to help ensure the minimum storage is available in the Preston Reservoir throughout the irrigation season.

ATTACHMENT B
Amador Regional Sanitation Authority
2025 Combined Water Balance

MCSP Wastewater Flow Information for Combined Water Balance
TM by KSN Inc.

THIS PAGE INTENTIONALLY LEFT BLANK

TECHNICAL MEMORANDUM

April 24, 2025

To: Isolette Gunther, California Department of Corrections and Rehabilitation
Laurie Perri, California Department of Corrections and Rehabilitation
Gregor Larabee, California Department of Corrections and Rehabilitation

Subject: Mule Creek State Prison Input to Combined Water Balance

Project: Mule Creek State Prison Water Balance Calculations and Revised Report of Waste Discharge

Prepared By: Jade A. Fredeen E.I.T.
Todd Thompson, R.C.E. 58278

Reviewed By: Neal T. Colwell R.C.E. 59437



1.0 Purpose and Objective

The purpose of this technical memorandum (TM) is to define and summarize the Mule Creek State Prison (MCSP) inputs to the combined waterbalance calculations in response to the California Central Valley Regional Water Quality Control Board's (Board, RWQCB) 13267 Order addressed jointly to the California Department of Corrections and Rehabilitation (CDCR), the City of Lone (City), and the Amador Regional Sanitation Authority (ARSA) dated August 14, 2024. The provided MCSP input to the combined waterbalance calculations is derived from modifications to the calculations performed for the Mule Creek State Prison Individual Waterbalance dated December 13, 2024 (modified February 24, 2025), which evaluated the treatment and disposal capacity of the Wastewater Treatment Plant (WWTP) serving MCSP, Mule Creek Infill Complex (MCIC), Preston Youth Correctional Facility (PYCF) and the CalFire Training Academy (CFTA). The input provided by MCSP to the combined waterbalance calculations is performed in accordance with the RWQCB's 13267 Order which intends to evaluate an optional avenue of conveyance, treatment, and disposal of wastewater effluent through interconnected operations between the MCSP, ARSA, and the City of Lone. The waterbalance combined calculations will be performed by HydroScience on behalf of ARSA. It is noted that MCSP is participating in the collaborative waterbalance effort with the understanding that the results of the joint calculations will be considered and are not obligatory.

2.0 Basis of Input to Combined Waterbalance

After the initial review of the MCSP Individual Waterbalance TM, additional waterbalance calculations for the 0.54 and 0.67 Mgal/d Average Dry Weather Flow (ADWF) scenarios were prepared to support discussions and coordination between all parties participating in the combined waterbalance effort. The waterbalance calculations prepared through this effort are provided in Exhibit A. Upon review of the average year flow scenario models, it was found that both of the average year ADWF



flows were able to be treated, stored, and disposed of at the MCSP WWTP facility through use of the on-site LAAs without the need for off-site discharges.

Under the 1 in 100 year precipitation season condition, the influent flow and disposal model at the current capacity ADWF of 0.54 Mgal/d was modified to establish the minimum discharge volume necessary to be sent to the Preston / Castle Oaks Water Recycling Plant (COWRP) system on a month to month basis to maintain compliance with permit requirements. The model was also analyzed to verify that the storage balance at the end of the water year could be accommodated in a following average year after a 1 in 100 year wet weather season. Results of the modified waterbalance indicate that a total of 9 Mgal (27.6 acre-feet) would need to be discharged to the COWRP system from May to September to maintain permit compliance in the 1 in 100 year condition and a following average year.

The MCSP maximum capacity condition of 0.67 Mgal/d ADWF initially performed under the Individual Waterbalance TM was re-evaluated under 1-in-100 year conditions to establish the minimum volume that MCSP would be required to deliver on a month to month basis to the Preston / COWRP system to come to an end of the water year storage balance that could be accommodated in a following average year through usage of existing disposal facilities. Results of the waterbalance indicate that a total of 82.6 Mgal (253.5 acre-feet) would need to be sent to the COWRP system to maintain permit compliance under the following conditions:

- 10.4 Mgal (31.9 acre-feet) to be sent from November to May, and
- 72.2 Mgal (221.6 acre-feet) to be sent from June to September.

A summary of the minimum required COWRP discharge to remain within storage capacity under 1 in 100 year and average precipitation season conditions is provided in Table 1.



Table 1
 MCSP Minimum Required COWRP Discharge, 1 in 100 and Average Year Conditions

1 in 100 Year CDCR Discharges to COWRP, Acre-feet	October	November	December	January	February	March	April	May	June	July	August	September	Total	
Preston System Discharge Required at 0.54 MGD MCSP ADWF*	0.0	0.0	0.0	0.0	0.0	0.0	0.0	27.6**					27.6	
Preston System Discharge Required at 0.67 MGD MCSP ADWF*	0.0	31.9**							221.6**					253.5
Average Year CDCR Discharges to COWRP, Acre-feet	October	November	December	January	February	March	April	May	June	July	August	September	Total	
Preston System Discharge Required at 0.54 MGD MCSP ADWF***	0.0	0.0	0.0	0.0	0.0	0.0	0.0	0.0	0.0	0.0	0.0	0.0	0.0	
Preston System Discharge Required at 0.67 MGD MCSP ADWF***	0.0	0.0	0.0	0.0	0.0	0.0	0.0	0.0	0.0	0.0	0.0	0.0	0.0	

Notes:

*Based on existing MCSP LAAs and on-site storage

**Total can be distributed as needed throughout specified timeframe

***Based on disposal needs under typical average water year conditions

Exhibit A

**MCSP COWRP Distribution Input to Combined
Waterbalance**

RECENT AVERAGE OCCUPANCY ADWF WATER BALANCE UNDER AVG YEAR TYPE HYDROLOGIC CONDITIONS, NO OFF-SITE DISCHARGES

SANITARY FLOW CHARACTERISTICS		INPUT DATA, CONSTANT				CLIMATOLOGICAL FACTORS			
STARTING AVERAGE FLOW (MGD)	0.54	CATCHMENT AREA (AC)	27.0	EXISTING STORAGE RESERVOIRS	21.6	CLIMATOLOGICAL DESIGN BASIS	Avg. Year Cond.		
IRRIGATION AREA CHARACTERISTICS		WATER SURFACE (AC)	9.6	BOTTOM SURFACE (AC)	155	DESIGN PRECIP/AVG PRECIP RATIO	1.00		
POST MCIC IRRIGATION AREA TOTAL (AC)	200	STORAGE AVAILABLE (MG)	0.40	EFFECTIVE STORAGE PERCOLATION RATE (IN/DAY)	0.28	OCT-APR EVAP/AVG EVAP RATIO	1.00		
POST MCIC IRRIGATION FIELDS 1-4 & 6 AREA (AC)	157	OXIDATION DITCH SURFACE AREA (AC)	0.18	COMBINED CLARIFIER SURFACE AREA (AC)	0.7	MAY-SEP EVAP/AVG EVAP RATIO	1.00		
POST MCIC IRRIGATION FIELD 7 AREA (AC)	43	CHLORINE CONTACT BASIN SURFACE AREA (AC)	1.2	TOTAL TREATMENT PROCESS SURFACE AREA (AC)	1.2	IRRIGATION AREA SOIL RUNOFF COEFFICIENT	0.05		
POST MCIC NEW AREA (AC)	0					STORAGE CATCHMENT SOIL RUNOFF COEFF	0.50		
POST MCIC NEW AREA W/II RESERVOIR (AC)	0					STORAGE CATCHMENT RESERVOIR RUNOFF COEFF	1.00		
IRRIGATION FIELD 7 MAX APPLICATION EFFICIENCY	1.10								
IRRIGATION FIELDS 1-4 & 6 MAX APPLICATION EFFICIENCY	0.60								

MONTH	INPUT DATA, MONTHLY VARIABLE												
	ANNUAL	OCT	NOV	DEC	JAN	FEB	MAR	APR	MAY	JUN	JUL	AUG	SEP
DAYS IN MONTH	365	31	30	31	31	28	31	30	31	30	31	31	30
AVERAGE DRY WEATHER FLOW (MGD)		0.54	0.54	0.54	0.54	0.54	0.54	0.54	0.54	0.54	0.54	0.54	0.54
AVG PRECIP, AVG OF IONE & PARDEE (IN)	21.8	0.31	1.17	2.69	3.49	4.52	3.35	3.29	1.82	0.74	0.25	0.06	0.10
ZONE 14 TYPICAL YEAR REFERENCE EVAPOTRANSPIRATION (Eto) (IN)	56.2	3.86	1.25	1.14	0.73	2.36	4.13	5.82	7.62	8.00	8.36	7.11	5.82
ZONE 12 WET REFERENCE EVAPOTRANSPIRATION (Eto) (IN)	53.4	3.72	1.25	0.93	1.24	1.56	3.41	5.10	6.82	7.80	8.06	7.13	5.40
WATER SURFACE EVAPORATION COEFFICIENT		1.00	1.00	1.00	1.00	1.00	1.00	1.00	1.00	1.00	1.00	1.00	1.00
CROP COEFFICIENT (Kc), EXISTING GRASSES		0.85	0.74	0.93	1.18	0.65	0.65	0.84	1.00	1.01	1.00	1.02	0.99
CROP COEFFICIENT (Kc), TREES (OAKS)		0.69	0.48	0.93	1.18	0.39	0.30	0.43	0.86	0.94	0.93	0.95	0.92
WEIGHTED Kc CROP COEFFICIENT FOR MCSP SITE		0.82	0.68	0.93	1.18	0.60	0.58	0.76	0.97	1.00	0.99	1.01	0.97
MCIC FACILITY II VOLUME (MGD)	0.000	0.000	0.001	0.002	0.002	0.000	0.000	0.005	0.000	0.000	0.000	0.000	0.000
MCSP, PYCF, CAL FIRE FACILITY II VOLUME (MGD)	0.000	0.000	0.000	0.043	0.032	0.026	0.035	0.011	0.006	0.001	0.000	0.000	0.000
TOTAL II VOLUME (MGD)	0.000	0.000	0.001	0.045	0.034	0.028	0.035	0.016	0.006	0.001	0.000	0.000	0.000
TOTAL INFLUENT FLOW RATE (MGD)		0.54	0.54	0.58	0.57	0.56	0.57	0.55	0.54	0.54	0.54	0.54	0.54

CALCULATIONS / MONTH	CALCULATIONS												
	ANNUAL	OCT	NOV	DEC	JAN	FEB	MAR	APR	MAY	JUN	JUL	AUG	SEP
RAIN-RELATED CALCULATIONS													
PERCENT ANNUAL RAINFALL(MONTH %)		1.4%	5.4%	12.4%	16.0%	20.8%	15.4%	15.1%	8.4%	3.4%	1.1%	0.3%	0.4%
ESTIMATED IONE-RAIN, Avg. Year Cond. (IN)	21.8	0.31	1.17	2.69	3.49	4.52	3.35	3.29	1.82	0.74	0.25	0.06	0.10
EFFECTIVE RAIN FOR PLANTS (IN)	20.7	0.29	1.11	2.56	3.32	4.29	3.18	3.12	1.73	0.70	0.23	0.05	0.09
EVAPORATION-RELATED CALCULATIONS													
EVAPOTRANSPIRATION POTENTIAL (IN) (Eto) (Eto * Weighted Kc)	51	3.16	0.86	1.06	0.86	1.42	2.40	4.41	7.38	7.97	8.24	7.15	5.67
Avg. Year Cond. DESIGN ET POTENTIAL (IN) (Eto * Seasonal Evaporation Ratio)	51	3.16	0.86	1.06	0.86	1.42	2.40	4.41	7.38	7.97	8.24	7.15	5.67
WWTP / STORAGE RESERVOIR EVAPORATION (IN) (Eto * Water Surface Coefficient)	56	3.86	1.25	1.14	0.73	2.36	4.13	5.82	7.62	8.00	8.36	7.11	5.82
SANITARY-RELATED CALCULATIONS													
AVERAGE DRY WEATHER FLOW VOLUME (MG)	195	16.6	16.1	16.6	16.6	15.0	16.6	16.1	16.6	16.1	16.6	16.6	16.1
II FLOW VOLUME (MG)	5	0.00	0.04	1.40	1.06	0.79	1.08	0.48	0.19	0.04	0.00	0.00	0.01
TOTAL INFLUENT FLOW VOLUME (MG)	201	16.7	16.2	18.0	17.7	15.8	17.7	16.6	16.8	16.2	16.7	16.7	16.1

DESIGN DISCHARGE TO FIELD 7													
BEGINNING AVAILABLE RAIN WATER IN SOIL (IN)		0.00	0.00	0.26	1.75	4.20	4.20	4.20	2.91	0.00	0.00	0.00	0.00
LAND AREA UNDER IRRIGATION (AC)		43	43	43	43	43	43	43	43	43	43	43	43
POTENTIAL Avg. Year Cond. EFFLUENT APPLICATION RATE (IN/MONTH)	37	3.15	0.00	0.00	0.00	0.00	0.00	0.00	3.01	8.00	8.81	7.81	6.14
POTENTIAL Avg. Year Cond. EFFLUENT APPLICATION VOLUME (MG)	43	3.68	0.00	0.00	0.00	0.00	0.00	0.00	3.52	9.34	10.29	9.12	7.16
MAX EFFLUENT VOLUME AVAILABLE FOR LAND (MG)		16.7	18.1	33.3	48.7	62.8	79.2	92.7	103.2	96.1	79.2	59.5	43.3
AVAILABLE EFFLUENT APPLIED TO LAND (MG)	43	3.68	0.00	0.00	0.00	0.00	0.00	0.00	3.52	9.34	10.29	9.12	7.16
AVERAGE EFFLUENT DISCHARGE RATE TO FIELD 7 (MGD)		0.12	0.00	0.00	0.00	0.00	0.00	0.00	0.11	0.31	0.33	0.29	0.24
EFFLUENT IRRIGATION RATE (IN/MONTH)	37	3.15	0.00	0.00	0.00	0.00	0.00	0.00	3.01	8.00	8.81	7.81	6.14
DESIGN DISCHARGE TO FIELDS 1-4 & 6													
BEGINNING AVAILABLE RAIN WATER IN SOIL (IN)		0.00	0.00	0.26	0.28	0.28	0.28	0.28	0.00	0.00	0.00	0.00	0.00
LAND AREA UNDER IRRIGATION (AC)		157	157	157	157	157	157	157	157	157	157	157	157
POTENTIAL Avg. Year Cond. EFFLUENT APPLICATION RATE (IN/MONTH)	22	1.72	0.00	0.00	0.00	0.00	0.00	0.00	0.61	3.39	4.36	4.81	4.26
POTENTIAL Avg. Year Cond. EFFLUENT APPLICATION VOLUME (MG)	96	7.32	0.00	0.00	0.00	0.00	0.00	0.00	2.58	14.45	18.60	20.49	18.16
REMAINING EFFLUENT VOLUME AVAILABLE FOR LAND (MG)		13.02	18.13	33.27	48.74	62.84	79.17	92.74	99.68	86.73	68.92	50.38	36.14
REMAINING AVAILABLE EFFLUENT APPLIED TO LAND (MG)	96	7.32	0.00	0.00	0.00	0.00	0.00	0.00	2.58	14.45	18.60	20.49	18.16
AVERAGE EFFLUENT DISCHARGE RATE (MGD)		0.24	0.00	0.00	0.00	0.00	0.00	0.00	0.09	0.47	0.62	0.66	0.59
EFFLUENT IRRIGATION RATE (IN/MONTH)	22	1.72	0.00	0.00	0.00	0.00	0.00	0.00	0.61	3.39	4.36	4.81	4.26
DESIGN DISCHARGE TO COWRP													
AVERAGE COWRP DISCHARGE (MGD)		0.00	0.00	0.00	0.00	0.00	0.00	0.00	0.00	0.00	0.00	0.00	0.00
MONTHLY DISCHARGE TO COWRP (MG)	0	0.0	0.0	0.0	0.0	0.0	0.0	0.0	0.0	0.0	0.0	0.0	0.0
HISTORICAL AVERAGE DISCHARGE TO COWRP (MG)	93.8	8.9	3.4	0.2	2.4	1.1	0.0	0.9	3.9	9.3	15.0	27.7	21.1
CDCR/ARSA AGREEMENT LIMITED PRESTON DISCHARGE (MG)	114	1.8	1.8	1.8	1.8	1.8	1.8	17.3	17.3	17.3	17.3	17.3	17.3
CDCR/ARSA AGREEMENT LIMITED PRESTON DISCHARGE (ACFT)	350	5.4	5.4	5.4	5.4	5.4	5.4	53.0	53.0	53.0	53.0	53.0	53.0
DESIGN LOSSES AND GAINS FROM STORAGE													
STORAGE AT BEGINNING OF MONTH (MG)		0.00	1.93	15.27	31.04	47.04	61.47	76.14	86.40	79.87	62.51	42.80	27.20
EFFLUENT STORAGE VOLUME GAIN/LOSS (MG)		5.71	16.20	18.00	17.70	15.80	17.70	14.02	-1.17	-11.74	-14.07	-10.58	-5.33
UNADJUSTED STORAGE VOLUME (MG)		5.71	18.13	33.27	48.74	62.84	79.17	90.16	85.23	68.13	48.43	32.22	21.87
APPROXIMATE EFFECTIVE RESERVOIR EVAP AREA (AC)		5.3	6.7	8.3	10.0	11.6	13.3	14.6	14.0	12.1	10.0	8.2	7.1
APPROXIMATE EFFECTIVE RESERVOIR PERC AREA (AC)		9.6	9.6	9.6	9.6	9.6	9.6	9.6	9.6	9.6	9.6	9.6	9.6
APPROXIMATE AREA OF WWTP PROCESSES (AC)		1.2	1.2	1.2	1.2	1.2	1.2	1.2	1.2	1.2	1.2	1.2	1.2
EVAPORATIVE LOSS FROM STORAGE (MG)	18	0.68	0.27	0.29	0.22	0.82	1.63	2.48	3.14	2.89	2.53	1.81	1.30
PERCOLATION LOSS FROM STORAGE (MG)	38	3.23	3.13	3.23	3.23	2.92	3.23	3.13	3.23	3.13	3.23	3.23	3.13
RUNOFF TO STORAGE FROM RAIN CATCHMENT AREA (MG)	11	0.14	0.53	1.29	1.75	2.36	1.83	1.85	1.01	0.39	0.12	0.03	0.04
PRECIP CAPTURED BY WWTP PROCESS AREAS (MG)	1	0.02	0.07	0.17	0.22	0.28	0.21	0.21	0.11	0.05	0.02	0.00	0.01
STORAGE AT END OF MONTH (MG)		1.93	15.27	31.04	47.04	61.47	76.14	86.40	79.87	62.51	42.80	27.20	17.49
												MAXIMUM STORAGE REQUIRED (MG)	86.4
												TOTAL AVAILABLE STORAGE (MG)	155.0

SUMMARY			
ANNUAL INFLOWS (MG)		ANNUAL OUTFLOWS (MG)	OVERALL BALANCE (MUST NOT BE NEGATIVE)
WASTEWATER	195	EVAPORATION	-18
INFLOW AND INFILTRATION	5	PERCOLATION	38
PRECIPITATION INTO WWTP AND RESERVOIR	13	ON-SITE LAND DISPOSAL	139
		DISCHARGE TO COWRP	0
TOTAL INFLOW	213	TOTAL OUTFLOW	195
		TOTAL UNUSED DISPOSAL CAPACITY (MG)	-18
		UNUSED LAA CAPACITY (MG)	0
		UNUSED COWRP CAPACITY (MG)	0
		TOTAL UNUSED STORAGE CAPACITY (MG)	69

RECENT AVERAGE OCCUPANCY ADWF WATER BALANCE UNDER 1-in-100 YEAR TYPE HYDROLOGIC CONDITIONS, EXISTING LAAs + MINIMUM REQUIRED DISCHARGE TO COWRP

SANITARY FLOW CHARACTERISTICS		INPUT DATA, CONSTANT				CLIMATOLOGICAL FACTORS			
STARTING AVERAGE FLOW (MGD)	0.54	CATCHMENT AREA (AC)	27.0	EXISTING STORAGE RESERVOIRS	21.6	CLIMATOLOGICAL DESIGN BASIS	1-in-100 YEAR	DESIGN PRECIP/AVG PRECIP RATIO	1.81
IRRIGATION AREA CHARACTERISTICS		WATER SURFACE (AC)	9.6	BOTTOM SURFACE (AC)	155	OCT-APR EVAP/AVG EVAP RATIO	0.75	MAY-SEP EVAP/AVG EVAP RATIO	1.00
POST MCIC IRRIGATION AREA TOTAL (AC)	200	STORAGE AVAILABLE (MG)	0.40	EFFECTIVE STORAGE PERCOLATION RATE (IN/DAY)	0.28	IRRIGATION AREA SOIL RUNOFF COEFFICIENT	0.05	STORAGE CATCHMENT SOIL RUNOFF COEFF	0.50
POST MCIC IRRIGATION FIELDS 1-4 & 6 AREA (AC)	157	EXISTING WWTP PROCESS AREAS		0.18	OXIDATION DITCH SURFACE AREA (AC)	0.7	STORAGE CATCHMENT RESERVOIR RUNOFF COEFF	1.00	
POST MCIC IRRIGATION FIELD 7 AREA (AC)	43	COMBINED CLARIFIER SURFACE AREA (AC)	0.7	CHLORINE CONTACT BASIN SURFACE AREA (AC)	1.2	TOTAL TREATMENT PROCESS SURFACE AREA (AC)			
POST MCIC NEW AREA (AC)	0								
POST MCIC NEW AREA W/ RESERVOIR (AC)	0								
IRRIGATION FIELD 7 MAX APPLICATION EFFICIENCY	1.10								
IRRIGATION FIELDS 1-4 & 6 MAX APPLICATION EFFICIENCY	0.60								

INPUT DATA, MONTHLY VARIABLE													
MONTH	ANNUAL	OCT	NOV	DEC	JAN	FEB	MAR	APR	MAY	JUN	JUL	AUG	SEP
DAYS IN MONTH	365	31	30	31	31	28	31	30	31	30	31	31	30
AVERAGE DRY WEATHER FLOW (MGD)		0.54	0.54	0.54	0.54	0.54	0.54	0.54	0.54	0.54	0.54	0.54	0.54
AVG PRECIP, AVG OF IONE & PARDEE (IN)	21.8	0.31	1.17	2.69	3.49	4.52	3.35	3.29	1.82	0.74	0.25	0.06	0.10
ZONE 14 WET YEAR REFERENCE EVAPOTRANSPIRATION (ET ₀) (IN)	45.6	3.86	1.19	1.17	0.41	0.87	2.90	4.30	4.13	6.63	7.87	7.21	5.01
WATER SURFACE EVAPORATION COEFFICIENT		1.00	1.00	1.00	1.00	1.00	1.00	1.00	1.00	1.00	1.00	1.00	1.00
CROP COEFFICIENT (K _c), EXISTING MISC. GRASSES		0.92	1.11	0.95	1.15	1.17	1.10	1.03	1.13	1.02	1.00	1.00	1.00
CROP COEFFICIENT (K _c), TREES (OAKS)		0.75	0.92	0.94	1.05	1.10	0.85	0.89	1.13	0.98	0.90	0.94	0.92
WEIGHTED CROP COEFFICIENT FOR MCSP SITE		0.88	1.07	0.95	1.13	1.16	1.05	1.10	1.13	1.01	0.98	0.99	0.98
PRESTON YOUTH FACILITY III VOLUME (MGD)		0.011	0.014	0.016	0.067	0.097	0.029	0.023	0.001	0.000	0.000	0.000	0.000
MCIC FACILITY III VOLUME (MGD)		0.013	0.002	0.000	0.000	0.001	0.005	0.010	0.002	0.002	0.000	0.000	0.000
MCSP + CAL FIRE FACILITY III VOLUME (MGD)		0.000	0.000	0.000	0.087	0.051	0.000	0.003	0.025	0.018	0.000	0.000	0.000
TOTAL III VOLUME (MGD)		0.024	0.016	0.016	0.154	0.149	0.034	0.036	0.028	0.020	0.000	0.000	0.000
TOTAL INFLUENT FLOW RATE (MGD)		0.56	0.55	0.55	0.69	0.68	0.57	0.57	0.56	0.56	0.54	0.54	0.54

CALCULATIONS													
CALCULATIONS / MONTH	ANNUAL	OCT	NOV	DEC	JAN	FEB	MAR	APR	MAY	JUN	JUL	AUG	SEP
RAIN-RELATED CALCULATIONS													
PERCENT ANNUAL RAINFALL MONTH (%)		1.4%	5.4%	12.4%	16.0%	20.8%	15.4%	15.1%	8.4%	3.4%	1.1%	0.3%	0.4%
ESTIMATED IONE RAIN, 1-in-100 YEAR (IN)	39.4	0.56	2.12	4.87	6.32	8.17	6.05	5.95	3.29	1.33	0.44	0.10	0.17
EFFECTIVE RAIN FOR PLANTS (IN)	37.4	0.53	2.01	4.63	6.00	7.76	5.75	5.65	3.13	1.26	0.42	0.09	0.16
EVAPORATION-RELATED CALCULATIONS													
EVAPOTRANSPIRATION POTENTIAL (IN) (ET ₀) (ET ₀ * Weighted K _c)	46	3.42	1.28	1.11	0.46	1.01	3.04	4.30	4.66	6.69	7.71	7.11	4.92
1-in-100 YEAR DESIGN ET POTENTIAL (IN) (ET ₀ * Seasonal Evaporation Ratio)	42	2.56	0.96	0.83	0.35	0.76	2.28	3.23	4.66	6.69	7.71	7.11	4.92
WWTP / STORAGE RESERVOIR EVAPORATION (IN) (ET ₀ * Water Surface Coefficient)	42	2.90	0.89	0.88	0.31	0.65	2.18	3.23	4.13	6.63	7.87	7.21	5.01
SANITARY-RELATED CALCULATIONS													
AVERAGE DRY WEATHER FLOW VOLUME (MG)	195	16.6	16.1	16.6	16.6	15.0	16.6	16.1	16.6	16.1	16.6	16.6	16.1
III FLOW VOLUME (MG)	14	0.74	0.48	0.50	4.77	4.17	1.05	1.08	0.87	0.60	0.00	0.00	0.00
TOTAL INFLUENT FLOW VOLUME (MG)	210	17.4	16.6	17.1	21.4	19.2	17.7	17.2	17.5	16.7	16.7	16.7	16.1

DESIGN DISCHARGE TO FIELD 7													
BEGINNING AVAILABLE RAIN WATER IN SOIL (IN)		0.00	0.00	1.05	4.20	4.20	4.20	4.20	4.20	2.67	0.00	0.00	0.00
LAND AREA UNDER IRRIGATION (AC)		43	43	43	43	43	43	43	43	43	43	43	43
POTENTIAL 1-in-100 YEAR EFFLUENT APPLICATION RATE (IN/MONTH)	26	2.23	0.00	0.00	0.00	0.00	0.00	0.00	0.00	3.04	8.02	7.71	5.23
POTENTIAL 1-in-100 YEAR EFFLUENT APPLICATION VOLUME (MG)	31	2.61	0.00	0.00	0.00	0.00	0.00	0.00	0.00	3.55	9.37	9.00	6.11
MAX EFFLUENT VOLUME AVAILABLE FOR LAND (MG)		17.4	22.7	37.6	58.2	77.7	97.2	114.1	130.8	132.1	125.9	108.1	91.2
AVAILABLE EFFLUENT APPLIED TO LAND (MG)	31	2.61	0.00	0.00	0.00	0.00	0.00	0.00	0.00	3.55	9.37	9.00	6.11
AVERAGE EFFLUENT DISCHARGE RATE TO FIELD 7 (MGD)		0.08	0.00	0.00	0.00	0.00	0.00	0.00	0.00	0.12	0.30	0.29	0.20
EFFLUENT IRRIGATION RATE (IN/MONTH)	26	2.23	0.00	0.00	0.00	0.00	0.00	0.00	0.00	3.04	8.02	7.71	5.23
DESIGN DISCHARGE TO FIELDS 1-4 & 6													
BEGINNING AVAILABLE RAIN WATER IN SOIL (IN)		0.00	0.00	0.28	0.28	0.28	0.28	0.28	0.28	0.00	0.00	0.00	0.00
LAND AREA UNDER IRRIGATION (AC)		157	157	157	157	157	157	157	157	157	157	157	157
POTENTIAL 1-in-100 YEAR EFFLUENT APPLICATION RATE (IN/MONTH)	17	1.22	0.00	0.00	0.00	0.00	0.00	0.00	0.00	0.75	3.26	4.38	2.85
POTENTIAL 1-in-100 YEAR EFFLUENT APPLICATION VOLUME (MG)	71	5.19	0.00	0.00	0.00	0.00	0.00	0.00	0.00	3.21	13.88	18.65	12.16
REMAINING EFFLUENT VOLUME AVAILABLE FOR LAND (MG)		14.79	22.72	37.60	58.20	77.73	97.23	114.09	130.79	128.60	116.50	99.05	85.06
REMAINING AVAILABLE EFFLUENT APPLIED TO LAND (MG)	71	5.19	0.00	0.00	0.00	0.00	0.00	0.00	0.00	3.21	13.88	18.65	12.16
AVERAGE EFFLUENT DISCHARGE RATE (MGD)		0.17	0.00	0.00	0.00	0.00	0.00	0.00	0.10	0.46	0.60	0.58	0.41
EFFLUENT IRRIGATION RATE (IN/MONTH)	17	1.22	0.00	0.00	0.00	0.00	0.00	0.00	0.75	3.26	4.38	4.21	2.85
DESIGN DISCHARGE TO COWRP													
AVERAGE COWRP DISCHARGE (MGD)		0.00	0.13	0.01	0.02	0.06	0.00	0.00	0.13	0.34	0.48	0.87	0.66
MONTHLY DISCHARGE TO COWRP (MG)	9	0.0	0.0	0.0	0.0	0.0	0.0	0.0	9.0	0.0	0.0	0.0	0.0
HISTORICAL AVERAGE DISCHARGE TO COWRP (MG)	93.8	8.9	3.4	0.2	2.4	1.1	0.0	0.9	3.9	9.3	15.0	27.7	21.1
CDCR/ARSA AGREEMENT LIMITED PRESTON DISCHARGE (MG)	114	1.8	1.8	1.8	1.8	1.8	1.8	17.3	17.3	17.3	17.3	17.3	17.3
CDCR/ARSA AGREEMENT LIMITED PRESTON DISCHARGE (ACFT)	350	5.4	5.4	5.4	5.4	5.4	5.4	53.0	53.0	53.0	53.0	53.0	53.0
DESIGN LOSSES AND GAINS FROM STORAGE													
STORAGE AT BEGINNING OF MONTH (MG)		0.00	6.12	20.50	36.80	58.53	79.53	96.89	113.29	115.45	109.16	91.36	75.07
EFFLUENT STORAGE VOLUME GAIN/LOSS (MG)		9.60	16.60	17.10	21.40	19.20	17.70	17.20	5.29	-0.72	-11.32	-10.24	-2.17
UNADJUSTED STORAGE VOLUME (MG)		9.60	22.72	37.60	58.20	77.73	97.23	114.09	118.58	114.72	97.85	81.12	72.90
APPROXIMATE EFFECTIVE RESERVOIR EVAP AREA (AC)		5.7	7.2	8.8	11.1	13.2	15.3	17.2	17.7	17.2	15.4	13.6	12.7
APPROXIMATE EFFECTIVE RESERVOIR PERC AREA (AC)		9.6	9.6	9.6	9.6	9.6	9.6	9.6	9.6	9.6	9.6	9.6	9.6
APPROXIMATE AREA OF WWTP PROCESSES (AC)		1.2	1.2	1.2	1.2	1.2	1.2	1.2	1.2	1.2	1.2	1.2	1.2
EVAPORATIVE LOSS FROM STORAGE (MG)	18	0.54	0.20	0.24	0.10	0.25	0.97	1.61	2.11	3.31	3.54	2.88	1.88
PERCOLATION LOSS FROM STORAGE (MG)	38	3.23	3.13	3.23	3.23	2.92	3.23	3.13	3.23	3.13	3.23	3.23	3.13
RUNOFF TO STORAGE FROM RAIN CATCHMENT AREA (MG)	22	0.25	0.98	2.37	3.26	4.46	3.48	3.57	2.00	0.80	0.26	0.05	0.09
PRECIP CAPTURED BY WWTP PROCESS AREAS (MG)	2	0.04	0.13	0.31	0.40	0.51	0.38	0.37	0.21	0.08	0.03	0.01	0.01
STORAGE AT END OF MONTH (MG)		6.12	20.50	36.80	58.53	79.53	96.89	113.29	115.45	109.16	91.36	75.07	68.00
MAXIMUM STORAGE REQUIRED (MG)..... 115.4													
TOTAL AVAILABLE STORAGE (MG)..... 155.0													

SUMMARY			
ANNUAL INFLOWS (MG)	ANNUAL OUTFLOWS (MG)	OVERALL BALANCE (MUST NOT BE NEGATIVE)	
WASTEWATER..... 195	EVAPORATION..... 18	TOTAL UNUSED DISPOSAL CAPACITY (MG)..... -66	
INFLOW AND INFILTRATION..... 14	PERCOLATION..... 38	UNUSED LAA CAPACITY (MG)..... 0	
PRECIPITATION INTO WWTP AND RESERVOIR..... 24	ON-SITE LAND DISPOSAL..... 102	UNUSED COWRP CAPACITY (MG)..... 0	
	DISCHARGE TO COWRP..... 9	TOTAL UNUSED STORAGE CAPACITY (MG)..... 40	
TOTAL INFLOW..... 233	TOTAL OUTFLOW..... 167		

RECENT AVERAGE OCCUPANCY ADWF WATER BALANCE AVERAGE YEAR FOLLOWING 1-in-100 YEAR TYPE HYDROLOGIC CONDITIONS, EXISTING LAAS + DISCHARGE TO COWRP 4/24/2025

SANITARY FLOW CHARACTERISTICS		INPUT DATA, CONSTANT				CLIMATOLOGICAL FACTORS			
STARTING AVERAGE FLOW (MGD)	0.54	CATCHMENT AREA (AC)	27.0	EXISTING STORAGE RESERVOIRS	21.6	CLIMATOLOGICAL DESIGN BASIS	Average		
IRRIGATION AREA CHARACTERISTICS		WATER SURFACE (AC)	9.6	BOTTOM SURFACE (AC)	155	DESIGN PRECIP/AVG PRECIP RATIO	1.00		
POST MCIC IRRIGATION AREA TOTAL (AC)	200	STORAGE AVAILABLE (MG)	0.40	EFFECTIVE STORAGE PERCOLATION RATE (IN/DAY)	0.28	OCT-APR EVAP/AVG EVAP RATIO	1.00		
POST MCIC IRRIGATION FIELDS 1-4 & 6 AREA (AC)	157	OXIDATION DITCH SURFACE AREA (AC)	0.18	COMBINED CLARIFIER SURFACE AREA (AC)	0.7	MAY-SEP EVAP/AVG EVAP RATIO	1.00		
POST MCIC IRRIGATION FIELD 7 AREA (AC)	43	CHLORINE CONTACT BASIN SURFACE AREA (AC)	1.2	TOTAL TREATMENT PROCESS SURFACE AREA (AC)	1.2	IRRIGATION AREA SOIL RUNOFF COEFFICIENT	0.05		
POST MCIC NEW AREA (AC)	0	EXISTING WWTP PROCESS AREAS							
POST MCIC NEW AREA W/II RESERVOIR (AC)	0	STORAGE CATCHMENT SOIL RUNOFF COEFF	1.00						
IRRIGATION FIELD 7 MAX APPLICATION EFFICIENCY	1.10								
IRRIGATION FIELDS 1-4 & 6 MAX APPLICATION EFFICIENCY	0.60								

MONTH	INPUT DATA, MONTHLY VARIABLE												
	ANNUAL	OCT	NOV	DEC	JAN	FEB	MAR	APR	MAY	JUN	JUL	AUG	SEP
DAYS IN MONTH	365	31	30	31	31	28	31	30	31	30	31	31	30
AVERAGE DRY WEATHER FLOW (MGD)		0.54	0.54	0.54	0.54	0.54	0.54	0.54	0.54	0.54	0.54	0.54	0.54
AVG PRECIP, AVG OF IONE & PARDEE (IN)	21.8	0.31	1.17	2.69	3.49	4.52	3.35	3.29	1.82	0.74	0.25	0.06	0.10
ZONE 14 TYPICAL YEAR REFERENCE EVAPOTRANSPIRATION (ET _o) (IN)	56.2	3.86	1.25	1.14	0.73	2.36	4.13	5.82	7.62	8.00	8.36	7.11	5.82
WATER SURFACE EVAPORATION COEFFICIENT		1.00	1.00	1.00	1.00	1.00	1.00	1.00	1.00	1.00	1.00	1.00	1.00
CROP COEFFICIENT (K _c), EXISTING MISC. GRASSES		0.92	1.06	0.97	0.64	0.43	0.77	0.76	0.61	0.84	0.94	1.01	0.86
CROP COEFFICIENT (K _c), TREES (OAKS)		0.75	0.88	0.96	0.59	0.41	0.60	0.66	0.61	0.82	0.85	0.95	0.79
WEIGHTED CROP COEFFICIENT FOR MCSP SITE		0.82	0.68	0.93	1.18	0.60	0.58	0.76	0.97	1.00	0.99	1.01	0.97
MCIC FACILITY II VOLUME (MGD)	0.000	0.001	0.001	0.002	0.002	0.002	0.000	0.005	0.000	0.000	0.000	0.000	0.000
MCSP, PYCF, CAL FIRE FACILITY III VOLUME (MGD)	0.000	0.000	0.000	0.043	0.032	0.026	0.035	0.011	0.006	0.001	0.000	0.000	0.000
TOTAL III VOLUME (MGD)	0.000	0.001	0.045	0.034	0.028	0.035	0.016	0.006	0.001	0.000	0.000	0.000	0.000
TOTAL INFLUENT FLOW RATE (MGD)	0.54	0.54	0.58	0.57	0.57	0.56	0.57	0.55	0.54	0.54	0.54	0.54	0.54

CALCULATIONS / MONTH	CALCULATIONS												
	ANNUAL	OCT	NOV	DEC	JAN	FEB	MAR	APR	MAY	JUN	JUL	AUG	SEP
RAIN-RELATED CALCULATIONS													
PERCENT ANNUAL RAINFALL MONTH (%)		1.4%	5.4%	12.4%	16.0%	20.8%	15.4%	15.1%	8.4%	3.4%	1.1%	0.3%	0.4%
ESTIMATED IONE RAIN, Average (IN)	21.8	0.31	1.17	2.69	3.49	4.52	3.35	3.29	1.82	0.74	0.25	0.06	0.10
EFFECTIVE RAIN FOR PLANTS (IN)	20.7	0.29	1.11	2.56	3.32	4.29	3.18	3.12	1.73	0.70	0.23	0.05	0.09
EVAPORATION-RELATED CALCULATIONS													
EVAPOTRANSPIRATION POTENTIAL (IN) (ET _o) (ET _o * Weighted K _c)	51	3.16	0.86	1.06	0.86	1.42	2.40	4.41	7.38	7.97	8.24	7.15	5.67
Average DESIGN ET POTENTIAL (IN) (ET _c * Seasonal Evaporation Ratio)	51	3.16	0.86	1.06	0.86	1.42	2.40	4.41	7.38	7.97	8.24	7.15	5.67
WWTP / STORAGE RESERVOIR EVAPORATION (IN) (ET _o * Water Surface Coefficient)	56	3.86	1.25	1.14	0.73	2.36	4.13	5.82	7.62	8.00	8.36	7.11	5.82
SANITARY-RELATED CALCULATIONS													
AVERAGE DRY WEATHER FLOW VOLUME (MG)	195	16.6	16.1	16.6	16.6	15.0	16.6	16.1	16.6	16.1	16.6	16.6	16.1
II FLOW VOLUME (MG)	5	0.00	0.04	1.40	1.06	0.79	1.08	0.48	0.19	0.04	0.00	0.00	0.01
TOTAL INFLUENT FLOW VOLUME (MG)	201	16.7	16.2	18.0	17.7	15.8	17.7	16.6	16.8	16.2	16.7	16.7	16.1

DESIGN DISCHARGE TO FIELD 7													
BEGINNING AVAILABLE RAIN WATER IN SOIL (IN)		0.00	0.00	0.26	1.75	4.20	4.20	4.20	2.91	0.00	0.00	0.00	0.00
LAND AREA UNDER IRRIGATION (AC)		43	43	43	43	43	43	43	43	43	43	43	43
POTENTIAL Average EFFLUENT APPLICATION RATE (IN/MONTH)	37	3.15	0.00	0.00	0.00	0.00	0.00	0.00	3.01	8.00	8.81	7.81	6.14
POTENTIAL Average EFFLUENT APPLICATION VOLUME (MG)	43	3.68	0.00	0.00	0.00	0.00	0.00	0.00	3.52	9.34	10.29	9.12	7.16
MAX EFFLUENT VOLUME AVAILABLE FOR LAND (MG)		84.7	85.4	96.6	112.0	126.0	140.9	154.2	164.1	152.0	123.9	88.5	45.1
AVAILABLE EFFLUENT APPLIED TO LAND (MG)	43	3.68	0.00	0.00	0.00	0.00	0.00	0.00	3.52	9.34	10.29	9.12	7.16
AVERAGE EFFLUENT DISCHARGE RATE TO FIELD 7 (MGD)		0.12	0.00	0.00	0.00	0.00	0.00	0.00	0.11	0.31	0.33	0.29	0.24
EFFLUENT IRRIGATION RATE (IN/MONTH)	37	3.15	0.00	0.00	0.00	0.00	0.00	0.00	3.01	8.00	8.81	7.81	6.14
DESIGN DISCHARGE TO FIELDS 1-4 & 6													
BEGINNING AVAILABLE RAIN WATER IN SOIL (IN)		0.00	0.00	0.26	0.28	0.28	0.28	0.28	0.00	0.00	0.00	0.00	0.00
LAND AREA UNDER IRRIGATION (AC)		157	157	157	157	157	157	157	157	157	157	157	157
POTENTIAL Average EFFLUENT APPLICATION RATE (IN/MONTH)	22	1.72	0.00	0.00	0.00	0.00	0.00	0.00	0.61	3.39	4.36	4.81	4.26
POTENTIAL Average EFFLUENT APPLICATION VOLUME (MG)	96	7.32	0.00	0.00	0.00	0.00	0.00	0.00	2.58	14.45	18.60	20.49	18.16
REMAINING EFFLUENT VOLUME AVAILABLE FOR LAND (MG)		81.02	85.40	96.59	111.96	125.97	140.87	154.20	160.59	142.62	113.61	79.36	37.99
REMAINING AVAILABLE EFFLUENT APPLIED TO LAND (MG)	96	7.32	0.00	0.00	0.00	0.00	0.00	0.00	2.58	14.45	18.60	20.49	18.16
AVERAGE EFFLUENT DISCHARGE RATE (MGD)		0.24	0.00	0.00	0.00	0.00	0.00	0.09	0.47	0.62	0.66	0.59	0.48
EFFLUENT IRRIGATION RATE (IN/MONTH)	22	1.72	0.00	0.00	0.00	0.00	0.00	0.61	3.39	4.36	4.81	4.26	3.35
DESIGN DISCHARGE TO COWRP													
AVERAGE COWRP DISCHARGE (MGD)		0.00	0.13	0.01	0.02	0.06	0.00	0.00	0.13	0.34	0.48	0.87	0.66
MONTHLY DISCHARGE TO COWRP (MG)	82.6	0.0	3.9	0.3	0.5	1.7	0.0	0.0	4.0	10.2	15.0	27.1	19.9
HISTORICAL AVERAGE DISCHARGE TO COWRP (MG)	93.8	8.9	3.4	0.2	2.4	1.1	0.0	0.9	3.9	9.3	15.0	27.7	21.1
CDCR/ARSA AGREEMENT LIMITED PRESTON DISCHARGE (MG)	114	1.8	1.8	1.8	1.8	1.8	1.8	17.3	17.3	17.3	17.3	17.3	17.3
CDCR/ARSA AGREEMENT LIMITED PRESTON DISCHARGE (ACFT)	350	5.4	5.4	5.4	5.4	5.4	5.4	53.0	53.0	53.0	53.0	53.0	53.0
DESIGN LOSSES AND GAINS FROM STORAGE													
STORAGE AT BEGINNING OF MONTH (MG)		68.00	69.20	78.59	94.26	110.17	123.17	137.60	147.31	135.75	107.20	71.78	29.05
EFFLUENT STORAGE VOLUME GAIN/LOSS (MG)		5.71	12.30	17.70	17.20	14.10	17.70	14.02	-5.17	-21.94	-29.07	-37.68	-25.23
UNADJUSTED STORAGE VOLUME (MG)		73.71	81.50	96.29	111.46	124.27	140.87	151.62	142.13	113.82	78.13	34.10	3.82
APPROXIMATE EFFECTIVE RESERVOIR EVAP AREA (AC)		12.7	13.6	15.2	16.9	18.3	20.1	21.3	20.2	17.1	13.2	8.4	5.1
APPROXIMATE EFFECTIVE RESERVOIR PERC AREA (AC)		9.6	9.6	9.6	9.6	9.6	9.6	9.6	9.6	9.6	9.6	9.6	9.6
APPROXIMATE AREA OF WWTP PROCESSES (AC)		1.2	1.2	1.2	1.2	1.2	1.2	1.2	1.2	1.2	1.2	1.2	1.2
EVAPORATIVE LOSS FROM STORAGE (MG)	25	1.46	0.50	0.51	0.36	1.25	2.38	3.55	4.43	3.98	3.27	1.85	0.99
PERCOLATION LOSS FROM STORAGE (MG)	38	3.23	3.13	3.23	3.23	2.92	3.23	3.13	3.23	3.13	3.23	3.23	3.13
RUNOFF TO STORAGE FROM RAIN CATCHMENT AREA (MG)	13	0.17	0.64	1.54	2.08	2.78	2.14	2.15	1.17	0.44	0.13	0.03	0.04
PRECIP CAPTURED BY WWTP PROCESS AREAS (MG)	1	0.02	0.07	0.17	0.22	0.22	0.21	0.21	0.11	0.05	0.02	0.00	0.01
STORAGE AT END OF MONTH (MG)		69.20	78.59	94.26	110.17	123.17	137.60	147.31	135.75	107.20	71.78	29.05	0.00
MAXIMUM STORAGE REQUIRED (MG)													147.3
TOTAL AVAILABLE STORAGE (MG)													155.0

ANNUAL INFLOWS (MG)			ANNUAL OUTFLOWS (MG)			OVERALL BALANCE (MUST NOT BE NEGATIVE)		
WASTEWATER	195		EVAPORATION	25		TOTAL UNUSED DISPOSAL CAPACITY (MG)	70	
INFLOW AND INFILTRATION	5		PERCOLATION	38		UNUSED LAA CAPACITY (MG)	0	
PRECIPITATION INTO WWTP AND RESERVOIR	15		ON-SITE LAND DISPOSAL	139		UNUSED COWRP CAPACITY (MG)	0	
TOTAL INFLOW	215		DISCHARGE TO COWRP	83		TOTAL UNUSED STORAGE CAPACITY (MG)	8	
			TOTAL OUTFLOW	285				

MAX POTENTIAL OCCUPANCY ADWF WATER BALANCE UNDER AVG YEAR TYPE HYDROLOGIC CONDITIONS, NO OFF-SITE DISCHARGES

SANITARY FLOW CHARACTERISTICS		INPUT DATA, CONSTANT				CLIMATOLOGICAL FACTORS			
STARTING AVERAGE FLOW (MGD)	0.67	CATCHMENT AREA (AC)	27.0	EXISTING STORAGE RESERVOIRS	21.6	CLIMATOLOGICAL DESIGN BASIS	Avg. Year Cond.		
IRRIGATION AREA CHARACTERISTICS		WATER SURFACE (AC)	9.6	BOTTOM SURFACE (AC)	155	DESIGN PRECIP/AVG PRECIP RATIO	1.00		
POST MCIC IRRIGATION AREA TOTAL (AC)	200	STORAGE AVAILABLE (MG)	0.40	EFFECTIVE STORAGE PERCOLATION RATE (IN/DAY)	0.28	OCT-APR EVAP/AVG EVAP RATIO	1.00		
POST MCIC IRRIGATION FIELDS 1-4 & 6 AREA (AC)	157	OXIDATION DITCH SURFACE AREA (AC)	0.18	COMBINED CLARIFIER SURFACE AREA (AC)	0.7	MAY-SEP EVAP/AVG EVAP RATIO	1.00		
POST MCIC IRRIGATION FIELD 7 AREA (AC)	43	CHLORINE CONTACT BASIN SURFACE AREA (AC)	1.2	TOTAL TREATMENT PROCESS SURFACE AREA (AC)	1.2	IRRIGATION AREA SOIL RUNOFF COEFFICIENT	0.05		
POST MCIC NEW AREA (AC)	0					STORAGE CATCHMENT SOIL RUNOFF COEFF	0.50		
POST MCIC NEW AREA W/II RESERVOIR (AC)	0					STORAGE CATCHMENT RESERVOIR RUNOFF COEFF	1.00		
IRRIGATION FIELD 7 MAX APPLICATION EFFICIENCY	1.10								
IRRIGATION FIELDS 1-4 & 6 MAX APPLICATION EFFICIENCY	0.60								

MONTH	INPUT DATA, MONTHLY VARIABLE												
	ANNUAL	OCT	NOV	DEC	JAN	FEB	MAR	APR	MAY	JUN	JUL	AUG	SEP
DAYS IN MONTH	365	31	30	31	31	28	31	30	31	30	31	31	30
AVERAGE DRY WEATHER FLOW (MGD)	0.67	0.67	0.67	0.67	0.67	0.67	0.67	0.67	0.67	0.67	0.67	0.67	0.67
AVG PRECIP, AVG OF IONE & PARDEE (IN)	21.8	0.31	1.17	2.69	3.49	4.52	3.35	3.29	1.82	0.74	0.25	0.06	0.10
ZONE 14 TYPICAL YEAR REFERENCE EVAPOTRANSPIRATION (ET _o) (IN)	56.2	3.86	1.25	1.14	0.73	2.36	4.13	5.82	7.62	8.00	8.36	7.11	5.82
ZONE 12 WET REFERENCE EVAPOTRANSPIRATION (ET _o) (IN)	53.4	3.72	1.20	0.93	1.24	1.56	3.41	5.10	6.82	7.80	8.06	7.13	5.40
WATER SURFACE EVAPORATION COEFFICIENT	1.00	1.00	1.00	1.00	1.00	1.00	1.00	1.00	1.00	1.00	1.00	1.00	1.00
CROP COEFFICIENT (K _c), EXISTING GRASSES	0.85	0.74	0.93	1.18	0.65	0.65	0.84	1.00	1.01	1.00	1.02	0.99	0.99
CROP COEFFICIENT (K _c), TREES (OAKS)	0.69	0.48	0.93	1.18	0.39	0.30	0.43	0.86	0.94	0.93	0.95	0.92	0.92
WEIGHTED CROP COEFFICIENT FOR MCSP SITE	0.82	0.68	0.93	1.18	0.60	0.58	0.76	0.97	1.00	0.99	1.01	0.97	0.97
MCIC FACILITY II VOLUME (MGD)	0.000	0.001	0.002	0.002	0.002	0.000	0.005	0.000	0.000	0.000	0.000	0.000	0.000
MCSP, PYCF, CAL FIRE FACILITY II VOLUME (MGD)	0.000	0.000	0.043	0.032	0.024	0.036	0.011	0.006	0.001	0.000	0.000	0.000	0.000
TOTAL II VOLUME (MGD)	0.000	0.001	0.045	0.034	0.026	0.036	0.016	0.006	0.001	0.000	0.000	0.000	0.000
TOTAL INFLUENT FLOW RATE (MGD)	0.67	0.67	0.72	0.70	0.70	0.71	0.69	0.68	0.67	0.67	0.67	0.67	0.67

CALCULATIONS / MONTH	CALCULATIONS												
	ANNUAL	OCT	NOV	DEC	JAN	FEB	MAR	APR	MAY	JUN	JUL	AUG	SEP
RAIN-RELATED CALCULATIONS													
PERCENT ANNUAL RAINFALL(MONTH %)		1.4%	5.4%	12.4%	16.0%	20.8%	15.4%	15.1%	8.4%	3.4%	1.1%	0.3%	0.4%
ESTIMATED IONE-RAIN, Avg. Year Cond. (IN)	21.8	0.31	1.17	2.69	3.49	4.52	3.35	3.29	1.82	0.74	0.25	0.06	0.10
EFFECTIVE RAIN FOR PLANTS (IN)	20.7	0.29	1.11	2.56	3.32	4.29	3.18	3.12	1.73	0.70	0.23	0.05	0.09
EVAPORATION-RELATED CALCULATIONS													
EVAPOTRANSPIRATION POTENTIAL (IN) (ET _o) (ET _o * Weighted K _c)	51	3.16	0.86	1.06	0.86	1.42	2.40	4.41	7.38	7.97	8.24	7.15	5.67
Avg. Year Cond. DESIGN ET POTENTIAL (IN) (ET _c * Seasonal Evaporation Ratio)	51	3.16	0.86	1.06	0.86	1.42	2.40	4.41	7.38	7.97	8.24	7.15	5.67
WWTP / STORAGE RESERVOIR EVAPORATION (IN) (ET _o * Water Surface Coefficient)	56	3.86	1.25	1.14	0.73	2.36	4.13	5.82	7.62	8.00	8.36	7.11	5.82
SANITARY-RELATED CALCULATIONS													
AVERAGE DRY WEATHER FLOW VOLUME (MG)	245	20.8	20.1	20.8	20.8	18.8	20.8	20.1	20.8	20.1	20.8	20.8	20.1
II FLOW VOLUME (MG)	5	0.00	0.04	1.40	1.06	0.74	1.13	0.48	0.19	0.04	0.00	0.00	0.01
TOTAL INFLUENT FLOW VOLUME (MG)	250	20.8	20.2	22.2	21.9	19.5	21.9	20.6	21.0	20.2	20.8	20.8	20.2

DESIGN DISCHARGE TO FIELD 7													
BEGINNING AVAILABLE RAIN WATER IN SOIL (IN)		0.00	0.00	0.26	1.75	4.20	4.20	4.20	2.91	0.00	0.00	0.00	0.00
LAND AREA UNDER IRRIGATION (AC)		43	43	43	43	43	43	43	43	43	43	43	43
POTENTIAL Avg. Year Cond. EFFLUENT APPLICATION RATE (IN/MONTH)	37	3.15	0.00	0.00	0.00	0.00	0.00	0.00	3.01	8.00	8.81	7.81	6.14
POTENTIAL Avg. Year Cond. EFFLUENT APPLICATION VOLUME (MG)	43	3.68	0.00	0.00	0.00	0.00	0.00	0.00	3.52	9.34	10.29	9.12	7.16
MAX EFFLUENT VOLUME AVAILABLE FOR LAND (MG)		20.8	26.2	45.5	65.2	83.0	103.6	121.0	135.3	131.5	117.9	101.4	88.4
AVAILABLE EFFLUENT APPLIED TO LAND (MG)	43	3.68	0.00	0.00	0.00	0.00	0.00	0.00	3.52	9.34	10.29	9.12	7.16
AVERAGE EFFLUENT DISCHARGE RATE TO FIELD 7 (MGD)		0.12	0.00	0.00	0.00	0.00	0.00	0.00	0.11	0.31	0.33	0.29	0.24
EFFLUENT IRRIGATION RATE (IN/MONTH)	37	3.15	0.00	0.00	0.00	0.00	0.00	0.00	3.01	8.00	8.81	7.81	6.14
DESIGN DISCHARGE TO FIELDS 1-4 & 6													
BEGINNING AVAILABLE RAIN WATER IN SOIL (IN)		0.00	0.00	0.26	0.28	0.28	0.28	0.28	0.00	0.00	0.00	0.00	0.00
LAND AREA UNDER IRRIGATION (AC)		157	157	157	157	157	157	157	157	157	157	157	157
POTENTIAL Avg. Year Cond. EFFLUENT APPLICATION RATE (IN/MONTH)	22	1.72	0.00	0.00	0.00	0.00	0.00	0.00	0.61	3.39	4.36	4.81	4.26
POTENTIAL Avg. Year Cond. EFFLUENT APPLICATION VOLUME (MG)	96	7.32	0.00	0.00	0.00	0.00	0.00	0.00	2.58	14.45	18.60	20.49	18.16
REMAINING EFFLUENT VOLUME AVAILABLE FOR LAND (MG)		17.12	26.19	45.51	65.18	83.03	103.56	120.95	131.74	122.15	107.64	92.25	81.23
REMAINING AVAILABLE EFFLUENT APPLIED TO LAND (MG)	96	7.32	0.00	0.00	0.00	0.00	0.00	0.00	2.58	14.45	18.60	20.49	18.16
AVERAGE EFFLUENT DISCHARGE RATE (MGD)		0.24	0.00	0.00	0.00	0.00	0.00	0.09	0.47	0.62	0.66	0.59	0.48
EFFLUENT IRRIGATION RATE (IN/MONTH)	22	1.72	0.00	0.00	0.00	0.00	0.00	0.61	3.39	4.36	4.81	4.26	3.35
DESIGN DISCHARGE TO COWRP													
AVERAGE COWRP DISCHARGE (MGD)	0	0.00	0.00	0.00	0.00	0.00	0.00	0.00	0.00	0.00	0.00	0.00	0.00
MONTHLY DISCHARGE TO COWRP (MG)		0.0	0.0	0.0	0.0	0.0	0.0	0.0	0.0	0.0	0.0	0.0	0.0
HISTORICAL AVERAGE DISCHARGE TO COWRP (MG)	93.8	8.9	3.4	0.2	2.4	1.1	0.0	0.9	3.9	9.3	15.0	27.7	21.1
CDCR/ARSA AGREEMENT LIMITED PRESTON DISCHARGE (MG)	114	1.8	1.8	1.8	1.8	1.8	1.8	17.3	17.3	17.3	17.3	17.3	17.3
CDCR/ARSA AGREEMENT LIMITED PRESTON DISCHARGE (ACFT)	350	5.4	5.4	5.4	5.4	5.4	5.4	53.0	53.0	53.0	53.0	53.0	53.0
DESIGN LOSSES AND GAINS FROM STORAGE													
STORAGE AT BEGINNING OF MONTH (MG)		0.00	5.99	23.31	43.28	63.53	81.66	100.35	114.26	111.29	97.12	80.56	68.19
EFFLUENT STORAGE VOLUME GAIN/LOSS (MG)		9.81	20.20	22.20	21.90	19.50	21.90	18.02	3.03	-7.74	-9.97	-6.48	-1.23
UNADJUSTED STORAGE VOLUME (MG)		9.81	26.19	45.51	65.18	83.03	103.56	118.37	117.29	103.55	87.15	74.09	66.96
APPROXIMATE EFFECTIVE RESERVOIR EVAP AREA (AC)		5.8	7.5	9.7	11.8	13.8	16.0	17.5	17.5	16.0	14.2	12.8	12.0
APPROXIMATE EFFECTIVE RESERVOIR PERC AREA (AC)		9.6	9.6	9.6	9.6	9.6	9.6	9.6	9.6	9.6	9.6	9.6	9.6
APPROXIMATE AREA OF WWTP PROCESSES (AC)		1.2	1.2	1.2	1.2	1.2	1.2	1.2	1.2	1.2	1.2	1.2	1.2
EVAPORATIVE LOSS FROM STORAGE (MG)	23	0.72	0.30	0.33	0.26	0.56	1.93	2.97	3.87	3.73	3.49	2.69	2.08
PERCOLATION LOSS FROM STORAGE (MG)	38	3.23	3.13	3.23	3.23	2.92	3.23	3.13	3.23	3.13	3.23	3.23	3.13
RUNOFF TO STORAGE FROM RAIN CATCHMENT AREA (MG)	12	0.14	0.55	1.34	1.84	2.50	1.95	1.99	1.10	0.43	0.14	0.03	0.05
PRECIP CAPTURED BY WWTP PROCESS AREAS (MG)	1	0.02	0.07	0.17	0.22	0.28	0.21	0.21	0.11	0.05	0.02	0.00	0.01
STORAGE AT END OF MONTH (MG)		5.99	23.31	43.28	63.53	81.66	100.35	114.26	111.29	97.12	80.56	68.19	61.80
												MAXIMUM STORAGE REQUIRED (MG)	114.3
												TOTAL AVAILABLE STORAGE (MG)	155.0

SUMMARY			
ANNUAL INFLOWS (MG)		ANNUAL OUTFLOWS (MG)	OVERALL BALANCE (MUST NOT BE NEGATIVE)
WASTEWATER	245	EVAPORATION	TOTAL UNUSED DISPOSAL CAPACITY (MG)
INFLOW AND INFILTRATION	5	PERCOLATION	UNUSED LAA CAPACITY (MG)
PRECIPITATION INTO WWTP AND RESERVOIR	13	ON-SITE LAND DISPOSAL	UNUSED COWRP CAPACITY (MG)
		DISCHARGE TO COWRP	TOTAL UNUSED STORAGE CAPACITY (MG)
TOTAL INFLOW	263	TOTAL OUTFLOW	200

SANITARY FLOW CHARACTERISTICS		INPUT DATA, CONSTANT				CLIMATOLOGICAL FACTORS			
STARTING AVERAGE FLOW (MGD)	0.67	CATCHMENT AREA (AC)	27.0	EXISTING STORAGE RESERVOIRS	21.6	CLIMATOLOGICAL DESIGN BASIS	1-in-100 YEAR	DESIGN PRECIP/AVG PRECIP RATIO	1.81
IRRIGATION AREA CHARACTERISTICS		WATER SURFACE (AC)	9.6	BOTTOM SURFACE (AC)	1.55	OCT-APR EVAP/AVG EVAP RATIO	0.75	MAY-SEP EVAP/AVG EVAP RATIO	1.00
POST MCIC IRRIGATION AREA TOTAL (AC)	200	STORAGE AVAILABLE (MG)	0.40	EFFECTIVE STORAGE PERCOLATION RATE (IN/DAY)	0.28	IRRIGATION AREA SOIL RUNOFF COEFFICIENT	0.05	STORAGE CATCHMENT SOIL RUNOFF COEFF	0.50
POST MCIC IRRIGATION FIELDS 1-4 & 6 AREA (AC)	157	EXISTING WWTP PROCESS AREAS		0.18	OXIDATION DITCH SURFACE AREA (AC)	0.7	STORAGE CATCHMENT RESERVOIR RUNOFF COEFF	1.00	
POST MCIC IRRIGATION FIELD 7 AREA (AC)	43	COMBINED CLARIFIER SURFACE AREA (AC)	0.7	CHLORINE CONTACT BASIN SURFACE AREA (AC)	1.2	TOTAL TREATMENT PROCESS SURFACE AREA (AC)			
POST MCIC NEW AREA (AC)	0								
POST MCIC NEW AREA W/ RESERVOIR (AC)	0								
IRRIGATION FIELD 7 MAX APPLICATION EFFICIENCY	1.10								
IRRIGATION FIELDS 1-4 & 6 MAX APPLICATION EFFICIENCY	0.60								

MONTH	INPUT DATA, MONTHLY VARIABLE												
	ANNUAL	OCT	NOV	DEC	JAN	FEB	MAR	APR	MAY	JUN	JUL	AUG	SEP
DAYS IN MONTH	365	31	30	31	31	28	31	30	31	30	31	31	30
AVERAGE DRY WEATHER FLOW (MGD)	0.67	0.67	0.67	0.67	0.67	0.67	0.67	0.67	0.67	0.67	0.67	0.67	0.67
AVG PRECIP, AVG OF IONE & PARDEE (IN)	21.8	0.31	1.17	2.69	3.49	4.52	3.35	3.29	1.82	0.74	0.25	0.06	0.10
ZONE 14 WET YEAR REFERENCE EVAPOTRANSPIRATION (ET ₀) (IN)	45.6	3.86	1.19	1.17	0.41	0.87	2.90	4.30	4.13	6.63	7.87	7.21	5.01
WATER SURFACE EVAPORATION COEFFICIENT	1.00	1.00	1.00	1.00	1.00	1.00	1.00	1.00	1.00	1.00	1.00	1.00	1.00
CROP COEFFICIENT (K _c), EXISTING MISC. GRASSES	0.92	1.11	0.95	1.15	1.17	1.10	1.03	1.13	1.13	1.02	1.00	1.00	1.00
CROP COEFFICIENT (K _c), TREES (OAKS)	0.75	0.92	0.94	1.05	1.10	0.85	0.89	1.13	0.98	0.90	0.94	0.92	0.92
WEIGHTED CROP COEFFICIENT FOR MCSP SITE	0.88	1.07	0.95	1.13	1.16	1.05	1.10	1.13	1.01	0.98	0.99	0.98	0.98
PRESTON YOUTH FACILITY III VOLUME (MGD)	0.011	0.014	0.016	0.067	0.097	0.029	0.023	0.001	0.000	0.000	0.000	0.000	0.000
MCIC FACILITY III VOLUME (MGD)	0.013	0.002	0.000	0.000	0.001	0.005	0.010	0.002	0.002	0.000	0.000	0.000	0.000
MCSP + CAL FIRE FACILITY III VOLUME (MGD)	0.000	0.000	0.000	0.087	0.051	0.000	0.003	0.025	0.018	0.000	0.000	0.000	0.000
TOTAL III VOLUME (MGD)	0.024	0.016	0.016	0.154	0.149	0.034	0.036	0.028	0.020	0.000	0.000	0.000	0.000
TOTAL INFLUENT FLOW RATE (MGD)	0.69	0.69	0.69	0.82	0.82	0.70	0.71	0.70	0.69	0.67	0.67	0.67	0.67

CALCULATIONS / MONTH	CALCULATIONS												
	ANNUAL	OCT	NOV	DEC	JAN	FEB	MAR	APR	MAY	JUN	JUL	AUG	SEP
RAIN-RELATED CALCULATIONS													
PERCENT ANNUAL RAINFALL MONTH (%)		1.4%	5.4%	12.4%	16.0%	20.8%	15.4%	15.1%	8.4%	3.4%	1.1%	0.3%	0.4%
ESTIMATED IONE RAIN, 1-in-100 YEAR (IN)	39.4	0.56	2.12	4.87	6.32	8.17	6.05	5.95	3.29	1.33	0.44	0.10	0.17
EFFECTIVE RAIN FOR PLANTS (IN)	37.4	0.53	2.01	4.63	6.00	7.76	5.75	5.65	3.13	1.26	0.42	0.09	0.16
EVAPORATION-RELATED CALCULATIONS													
EVAPOTRANSPIRATION POTENTIAL (IN) (ET ₀ * Weighted K _c)	46	3.42	1.28	1.11	0.46	1.01	3.04	4.30	4.66	6.69	7.71	7.11	4.92
1-in-100 YEAR DESIGN ET POTENTIAL (IN) (ET ₀ * Seasonal Evaporation Ratio)	42	2.56	0.96	0.83	0.35	0.76	2.28	3.23	4.66	6.69	7.71	7.11	4.92
WWTP / STORAGE RESERVOIR EVAPORATION (IN) (ET ₀ * Water Surface Coefficient)	42	2.90	0.89	0.88	0.31	0.65	2.18	3.23	4.13	6.63	7.87	7.21	5.01
SANITARY-RELATED CALCULATIONS													
AVERAGE DRY WEATHER FLOW VOLUME (MG)	245	20.8	20.1	20.8	20.8	18.8	20.8	20.1	20.8	20.1	20.8	20.8	20.1
III FLOW VOLUME (MG)	14	0.74	0.48	0.50	4.77	4.17	1.05	1.08	0.87	0.60	0.00	0.00	0.00
TOTAL INFLUENT FLOW VOLUME (MG)	259	21.6	20.6	21.3	25.6	23.0	21.9	21.2	21.7	20.7	20.8	20.8	20.1

DESIGN DISCHARGE TO FIELD 7													
BEGINNING AVAILABLE RAIN WATER IN SOIL (IN)		0.00	0.00	1.05	4.20	4.20	4.20	4.20	4.20	2.67	0.00	0.00	0.00
LAND AREA UNDER IRRIGATION (AC)		43	43	43	43	43	43	43	43	43	43	43	43
POTENTIAL 1-in-100 YEAR EFFLUENT APPLICATION RATE (IN/MONTH)	26	2.23	0.00	0.00	0.00	0.00	0.00	0.00	0.00	3.04	8.02	7.71	5.23
POTENTIAL 1-in-100 YEAR EFFLUENT APPLICATION VOLUME (MG)	31	2.61	0.00	0.00	0.00	0.00	0.00	0.00	0.00	3.55	9.37	9.00	6.11
MAX EFFLUENT VOLUME AVAILABLE FOR LAND (MG)		21.6	30.8	45.9	70.1	92.7	114.3	134.8	155.3	165.2	152.4	123.4	83.6
AVAILABLE EFFLUENT APPLIED TO LAND (MG)	31	2.61	0.00	0.00	0.00	0.00	0.00	0.00	0.00	3.55	9.37	9.00	6.11
AVERAGE EFFLUENT DISCHARGE RATE TO FIELD 7 (MGD)		0.08	0.00	0.00	0.00	0.00	0.00	0.00	0.00	0.12	0.30	0.29	0.20
EFFLUENT IRRIGATION RATE (IN/MONTH)	26	2.23	0.00	0.00	0.00	0.00	0.00	0.00	0.00	3.04	8.02	7.71	5.23
DESIGN DISCHARGE TO FIELDS 1-4 & 6													
BEGINNING AVAILABLE RAIN WATER IN SOIL (IN)		0.00	0.00	0.28	0.28	0.28	0.28	0.28	0.28	0.00	0.00	0.00	0.00
LAND AREA UNDER IRRIGATION (AC)		157	157	157	157	157	157	157	157	157	157	157	157
POTENTIAL 1-in-100 YEAR EFFLUENT APPLICATION RATE (IN/MONTH)	17	1.22	0.00	0.00	0.00	0.00	0.00	0.00	0.00	0.75	3.26	4.38	2.85
POTENTIAL 1-in-100 YEAR EFFLUENT APPLICATION VOLUME (MG)	71	5.19	0.00	0.00	0.00	0.00	0.00	0.00	0.00	3.21	13.88	18.65	12.16
REMAINING EFFLUENT VOLUME AVAILABLE FOR LAND (MG)		18.99	30.85	45.90	70.14	92.66	114.28	134.80	155.32	161.70	143.01	114.37	77.52
REMAINING AVAILABLE EFFLUENT APPLIED TO LAND (MG)	71	5.19	0.00	0.00	0.00	0.00	0.00	0.00	0.00	3.21	13.88	18.65	12.16
AVERAGE EFFLUENT DISCHARGE RATE (MGD)		0.17	0.00	0.00	0.00	0.00	0.00	0.00	0.10	0.46	0.60	0.58	0.41
EFFLUENT IRRIGATION RATE (IN/MONTH)	17	1.22	0.00	0.00	0.00	0.00	0.00	0.00	0.75	3.26	4.38	4.21	2.85
DESIGN DISCHARGE TO COWRP													
AVERAGE COWRP DISCHARGE (MGD)		0.00	0.13	0.01	0.02	0.06	0.00	0.00	0.13	0.34	0.48	0.87	0.66
MONTHLY DISCHARGE TO COWRP (MG)	82.6	0.0	3.9	0.3	0.5	1.7	0.0	0.0	4.0	10.2	15.0	27.1	19.9
HISTORICAL AVERAGE DISCHARGE TO COWRP (MG)	93.8	8.9	3.4	0.2	2.4	1.1	0.0	0.9	3.9	9.3	15.0	27.1	21.1
CDCR/ARSA AGREEMENT LIMITED PRESTON DISCHARGE (MG)	114	1.8	1.8	1.8	1.8	1.8	1.8	17.3	17.3	17.3	17.3	17.3	17.3
CDCR/ARSA AGREEMENT LIMITED PRESTON DISCHARGE (ACFT)	350	5.4	5.4	5.4	5.4	5.4	5.4	53.0	53.0	53.0	53.0	53.0	53.0
DESIGN LOSSES AND GAINS FROM STORAGE													
STORAGE AT BEGINNING OF MONTH (MG)		0.00	10.25	24.60	44.54	69.66	92.38	113.60	133.62	144.54	131.57	102.58	63.53
EFFLUENT STORAGE VOLUME GAIN/LOSS (MG)		13.80	16.70	21.00	25.10	21.30	21.90	21.20	14.49	-6.92	-22.22	-33.24	-18.07
UNADJUSTED STORAGE VOLUME (MG)		13.80	26.95	45.60	69.64	90.96	114.28	134.80	148.11	137.62	109.35	69.34	45.46
APPROXIMATE EFFECTIVE RESERVOIR EVAP AREA (AC)		6.2	7.6	9.7	12.3	14.6	17.2	19.4	20.9	19.7	16.7	12.3	9.7
APPROXIMATE EFFECTIVE RESERVOIR PERC AREA (AC)		9.6	9.6	9.6	9.6	9.6	9.6	9.6	9.6	9.6	9.6	9.6	9.6
APPROXIMATE AREA OF WWTP PROCESSES (AC)		1.2	1.2	1.2	1.2	1.2	1.2	1.2	1.2	1.2	1.2	1.2	1.2
EVAPORATIVE LOSS FROM STORAGE (MG)	18	0.58	0.21	0.26	0.11	0.28	1.08	1.80	2.47	3.76	3.61	2.63	1.47
PERCOLATION LOSS FROM STORAGE (MG)	38	3.23	3.13	3.23	3.23	2.92	3.23	3.13	3.23	3.13	3.23	3.23	3.13
RUNOFF TO STORAGE FROM RAIN CATCHMENT AREA (MG)	22	0.25	1.00	2.42	3.37	4.62	3.63	3.75	2.14	0.84	0.26	0.05	0.09
PRECIP CAPTURED BY WWTP PROCESS AREAS (MG)	2	0.04	0.13	0.31	0.40	0.51	0.38	0.37	0.21	0.08	0.03	0.01	0.01
STORAGE AT END OF MONTH (MG)		10.25	24.60	44.54	69.66	92.38	113.60	133.62	144.54	131.57	102.58	63.53	40.95
MAXIMUM STORAGE REQUIRED (MG)..... 144.5													
TOTAL AVAILABLE STORAGE (MG)..... 155.0													

SUMMARY			
ANNUAL INFLOWS (MG)		ANNUAL OUTFLOWS (MG)	OVERALL BALANCE (MUST NOT BE NEGATIVE)
WASTEWATER	245	EVAPORATION	18
INFLOW AND INFILTRATION	14	PERCOLATION	38
PRECIPITATION INTO WWTP AND RESERVOIR	25	ON-SITE LAND DISPOSAL	102
		DISCHARGE TO COWRP	83
TOTAL INFLOW	284	TOTAL OUTFLOW	241
		TOTAL UNUSED DISPOSAL CAPACITY (MG)	-43
		UNUSED LAA CAPACITY (MG)	0
		UNUSED COWRP CAPACITY (MG)	0
		TOTAL UNUSED STORAGE CAPACITY (MG)	10

MAX POTENTIAL OCCUPANCY ADWF WATER BALANCE AVERAGE YEAR FOLLOWING AVERAGE YEAR TYPE HYDROLOGIC CONDITIONS, EXISTING LAAS + DISCHARGE TO COWRP 4/24/2025

SANITARY FLOW CHARACTERISTICS		INPUT DATA, CONSTANT				CLIMATOLOGICAL FACTORS			
STARTING AVERAGE FLOW (MGD)	0.67	CATCHMENT AREA (AC)	27.0	EXISTING STORAGE RESERVOIRS	21.6	CLIMATOLOGICAL DESIGN BASIS	Average		
IRRIGATION AREA CHARACTERISTICS		WATER SURFACE (AC)	9.6	BOTTOM SURFACE (AC)	155	DESIGN PRECIP/AVG PRECIP RATIO	1.00		
POST MCIC IRRIGATION AREA TOTAL (AC)	200	STORAGE AVAILABLE (MG)	0.40	EFFECTIVE STORAGE PERCOLATION RATE (IN/DAY)	0.28	OCT-APR EVAP/AVG EVAP RATIO	1.00		
POST MCIC IRRIGATION FIELDS 1-4 & 6 AREA (AC)	157	OXIDATION DITCH SURFACE AREA (AC)	0.18	COMBINED CLARIFIER SURFACE AREA (AC)	0.7	MAY-SEP EVAP/AVG EVAP RATIO	1.00		
POST MCIC IRRIGATION FIELD 7 AREA (AC)	43	CHLORINE CONTACT BASIN SURFACE AREA (AC)	1.2	TOTAL TREATMENT PROCESS SURFACE AREA (AC)	1.2	IRRIGATION AREA SOIL RUNOFF COEFFICIENT	0.05		
POST MCIC NEW AREA (AC)	0	EXISTING WWTP PROCESS AREAS							
POST MCIC NEW AREA W/II RESERVOIR (AC)	0	STORAGE CATCHMENT SOIL RUNOFF COEFF							
IRRIGATION FIELD 7 MAX APPLICATION EFFICIENCY	1.10	STORAGE RESERVOIR RUNOFF COEFF							
IRRIGATION FIELDS 1-4 & 6 MAX APPLICATION EFFICIENCY	0.60								

MONTH	INPUT DATA, MONTHLY VARIABLE												
	ANNUAL	OCT	NOV	DEC	JAN	FEB	MAR	APR	MAY	JUN	JUL	AUG	SEP
DAYS IN MONTH	365	31	30	31	31	28	31	30	31	30	31	31	30
AVERAGE DRY WEATHER FLOW (MGD)	0.67	0.67	0.67	0.67	0.67	0.67	0.67	0.67	0.67	0.67	0.67	0.67	0.67
AVG PRECIP, AVG OF IONE & PARDEE (IN)	21.8	0.31	1.17	2.69	3.49	4.52	3.35	3.29	1.82	0.74	0.25	0.06	0.10
ZONE 14 TYPICAL YEAR REFERENCE EVAPOTRANSPIRATION (ET _o) (IN)	56.2	3.86	1.25	1.14	0.73	2.36	4.13	5.82	7.62	8.00	8.36	7.11	5.82
WATER SURFACE EVAPORATION COEFFICIENT	1.00	1.00	1.00	1.00	1.00	1.00	1.00	1.00	1.00	1.00	1.00	1.00	1.00
CROP COEFFICIENT (K _c), EXISTING MISC. GRASSES	0.92	1.06	0.97	0.64	0.43	0.77	0.76	0.61	0.84	0.94	1.01	0.86	0.86
CROP COEFFICIENT (K _c), TREES (OAKS)	0.75	0.88	0.96	0.59	0.41	0.60	0.66	0.61	0.82	0.85	0.95	0.79	0.79
WEIGHTED CROP COEFFICIENT FOR MCSP SITE	0.88	1.02	0.97	0.63	0.43	0.74	0.74	0.61	0.84	0.92	1.00	0.85	0.85
MCIC FACILITY II VOLUME (MGD)	0.000	0.001	0.002	0.002	0.002	0.000	0.005	0.000	0.000	0.000	0.000	0.000	0.000
MCSP, PYCF, CAL FIRE FACILITY III VOLUME (MGD)	0.000	0.000	0.043	0.032	0.026	0.035	0.011	0.006	0.001	0.000	0.000	0.000	0.000
TOTAL III VOLUME (MGD)	0.000	0.001	0.045	0.034	0.028	0.035	0.016	0.006	0.001	0.000	0.000	0.000	0.000
TOTAL INFLUENT FLOW RATE (MGD)	0.67	0.67	0.72	0.70	0.70	0.70	0.69	0.68	0.67	0.67	0.67	0.67	0.67

CALCULATIONS / MONTH	CALCULATIONS												
	ANNUAL	OCT	NOV	DEC	JAN	FEB	MAR	APR	MAY	JUN	JUL	AUG	SEP
RAIN-RELATED CALCULATIONS													
PERCENT ANNUAL RAINFALL MONTH (%)		1.4%	5.4%	12.4%	16.0%	20.8%	15.4%	15.1%	8.4%	3.4%	1.1%	0.3%	0.4%
ESTIMATED IONE RAIN, Average (IN)	21.8	0.31	1.17	2.69	3.49	4.52	3.35	3.29	1.82	0.74	0.25	0.06	0.10
EFFECTIVE RAIN FOR PLANTS (IN)	20.7	0.29	1.11	2.56	3.32	4.29	3.18	3.12	1.73	0.70	0.23	0.05	0.09
EVAPORATION-RELATED CALCULATIONS													
EVAPOTRANSPIRATION POTENTIAL (IN) (ET _o) (ET _o * Weighted K _c)	46	3.42	1.28	1.11	0.46	1.01	3.04	4.30	4.66	6.69	7.71	7.11	4.92
Average DESIGN ET POTENTIAL (IN) (ET _c * Seasonal Evaporation Ratio)	46	3.42	1.28	1.11	0.46	1.01	3.04	4.30	4.66	6.69	7.71	7.11	4.92
WWTP / STORAGE RESERVOIR EVAPORATION (IN) (ET _o * Water Surface Coefficient)	56	3.86	1.25	1.14	0.73	2.36	4.13	5.82	7.62	8.00	8.36	7.11	5.82
SANITARY-RELATED CALCULATIONS													
AVERAGE DRY WEATHER FLOW VOLUME (MG)	245	20.8	20.1	20.8	20.8	18.8	20.8	20.1	20.8	20.1	20.8	20.8	20.1
II FLOW VOLUME (MG)	5	0.00	0.04	1.40	1.06	0.79	1.08	0.48	0.19	0.04	0.00	0.00	0.01
TOTAL INFLUENT FLOW VOLUME (MG)	250	20.8	20.2	22.2	21.9	19.6	21.9	20.6	21.0	20.2	20.8	20.8	20.2

DESIGN DISCHARGE TO FIELD 7													
BEGINNING AVAILABLE RAIN WATER IN SOIL (IN)		0.00	0.00	0.00	1.45	4.20	4.20	4.20	3.02	0.09	0.00	0.00	0.00
LAND AREA UNDER IRRIGATION (AC)		43	43	43	43	43	43	43	43	43	43	43	43
POTENTIAL Average EFFLUENT APPLICATION RATE (IN/MONTH)	31	3.43	0.18	0.00	0.00	0.00	0.00	0.00	0.00	6.50	8.23	7.76	5.31
POTENTIAL Average EFFLUENT APPLICATION VOLUME (MG)	37	4.01	0.21	0.00	0.00	0.00	0.00	0.00	0.00	7.59	9.61	9.06	6.20
MAX EFFLUENT VOLUME AVAILABLE FOR LAND (MG)		61.8	65.7	80.5	100.1	117.9	136.9	154.3	168.7	170.7	151.2	121.2	81.5
AVAILABLE EFFLUENT APPLIED TO LAND (MG)	37	4.01	0.21	0.00	0.00	0.00	0.00	0.00	0.00	7.59	9.61	9.06	6.20
AVERAGE EFFLUENT DISCHARGE RATE TO FIELD 7 (MGD)		0.13	0.01	0.00	0.00	0.00	0.00	0.00	0.00	0.25	0.31	0.29	0.21
EFFLUENT IRRIGATION RATE (IN/MONTH)	31	3.43	0.18	0.00	0.00	0.00	0.00	0.00	0.00	6.50	8.23	7.76	5.31
DESIGN DISCHARGE TO FIELDS 1-4 & 6													
BEGINNING AVAILABLE RAIN WATER IN SOIL (IN)		0.00	0.00	0.00	0.28	0.28	0.28	0.28	0.00	0.00	0.00	0.00	0.00
LAND AREA UNDER IRRIGATION (AC)		157	157	157	157	157	157	157	157	157	157	157	157
POTENTIAL Average EFFLUENT APPLICATION RATE (IN/MONTH)	19	1.87	0.10	0.00	0.00	0.00	0.00	0.00	0.54	1.76	3.60	4.49	2.90
POTENTIAL Average EFFLUENT APPLICATION VOLUME (MG)	83	7.98	0.42	0.00	0.00	0.00	0.00	0.00	2.30	7.51	15.33	19.14	12.35
REMAINING EFFLUENT VOLUME AVAILABLE FOR LAND (MG)		57.74	65.51	80.52	100.08	117.85	136.95	154.31	168.69	163.12	141.63	112.17	75.28
REMAINING AVAILABLE EFFLUENT APPLIED TO LAND (MG)	83	7.98	0.42	0.00	0.00	0.00	0.00	0.00	2.30	7.51	15.33	19.14	12.35
AVERAGE EFFLUENT DISCHARGE RATE (MGD)		0.26	0.01	0.00	0.00	0.00	0.00	0.00	0.08	0.24	0.51	0.62	0.58
EFFLUENT IRRIGATION RATE (IN/MONTH)	19	1.87	0.10	0.00	0.00	0.00	0.00	0.00	0.54	1.76	3.60	4.49	2.90
DESIGN DISCHARGE TO COWRP													
AVERAGE COWRP DISCHARGE (MGD)		0.00	0.13	0.01	0.02	0.06	0.00	0.00	0.13	0.34	0.48	0.87	0.66
MONTHLY DISCHARGE TO COWRP (MG)	82.6	0.0	3.9	0.3	0.5	1.7	0.0	0.0	4.0	10.2	15.0	27.1	19.9
HISTORICAL AVERAGE DISCHARGE TO COWRP (MG)	93.8	8.9	3.4	0.2	2.4	1.1	0.0	0.9	3.9	9.3	15.0	27.7	21.1
CDCR/ARSA AGREEMENT LIMITED PRESTON DISCHARGE (MG)	114	1.8	1.8	1.8	1.8	1.8	1.8	17.3	17.3	17.3	17.3	17.3	17.3
CDCR/ARSA AGREEMENT LIMITED PRESTON DISCHARGE (ACFT)	350	5.4	5.4	5.4	5.4	5.4	5.4	53.0	53.0	53.0	53.0	53.0	53.0
DESIGN LOSSES AND GAINS FROM STORAGE													
STORAGE AT BEGINNING OF MONTH (MG)		40.95	45.52	58.32	78.18	98.25	115.05	133.71	147.69	150.51	130.44	100.43	61.28
EFFLUENT STORAGE VOLUME GAIN/LOSS (MG)		8.81	15.67	21.90	21.40	17.90	21.90	19.30	9.49	-12.91	-22.94	-33.40	-18.25
UNADJUSTED STORAGE VOLUME (MG)		49.76	61.19	80.22	99.58	116.15	136.95	152.01	157.18	137.59	107.50	67.02	43.03
APPROXIMATE EFFECTIVE RESERVOIR EVAP AREA (AC)		10.1	11.4	13.5	15.6	17.4	19.7	21.3	21.9	19.7	16.4	12.0	9.4
APPROXIMATE EFFECTIVE RESERVOIR PERC AREA (AC)		9.6	9.6	9.6	9.6	9.6	9.6	9.6	9.6	9.6	9.6	9.6	9.6
APPROXIMATE AREA OF WWTP PROCESSES (AC)		1.2	1.2	1.2	1.2	1.2	1.2	1.2	1.2	1.2	1.2	1.2	1.2
EVAPORATIVE LOSS FROM STORAGE (MG)	27	1.18	0.43	0.45	0.33	1.19	2.34	3.55	4.77	4.54	4.00	2.54	1.67
PERCOLATION LOSS FROM STORAGE (MG)	38	3.23	3.13	3.23	3.23	2.92	3.23	3.13	3.23	3.13	3.23	3.23	3.13
RUNOFF TO STORAGE FROM RAIN CATCHMENT AREA (MG)	13	0.16	0.61	1.48	2.02	2.72	2.12	2.16	1.21	0.47	0.14	0.03	0.05
PRECIP CAPTURED BY WWTP PROCESS AREAS (MG)	1	0.02	0.07	0.17	0.22	0.28	0.21	0.21	0.11	0.05	0.02	0.00	0.01
STORAGE AT END OF MONTH (MG)		45.52	58.32	78.18	98.25	115.05	133.71	147.69	150.51	130.44	100.43	61.28	38.29
												MAXIMUM STORAGE REQUIRED (MG)	150.5
												TOTAL AVAILABLE STORAGE (MG)	155.0

SUMMARY				OVERALL BALANCE (MUST NOT BE NEGATIVE)			
ANNUAL INFLOWS (MG)		ANNUAL OUTFLOWS (MG)					
WASTEWATER	245	EVAPORATION	27	TOTAL UNUSED DISPOSAL CAPACITY (MG)	3		
INFLOW AND INFILTRATION	5	PERCOLATION	38	UNUSED LAA CAPACITY (MG)	0		
PRECIPITATION INTO WWTP AND RESERVOIR	15	ON-SITE LAND DISPOSAL	120	UNUSED COWRP CAPACITY (MG)	0		
TOTAL INFLOW	265	DISCHARGE TO COWRP	83	TOTAL UNUSED STORAGE CAPACITY (MG)	4		
			TOTAL OUTFLOW	268			

ATTACHMENT C
Amador Regional Sanitation Authority
2025 Combined Water Balance

2025 Detailed Combined Water Balance Calculations

THIS PAGE INTENTIONALLY LEFT BLANK

ARSA, COWRF/COGC, and MCSP Combined Water Balance Update

Scenario 2: MCSP ADWF 0.67 MGD

Future Flows & Facilities, Calibrated at 2016/17 Rainfall Distribution

August 2025 By: Bill Slenter/Steven Whittlesey, HydroScience

<u>WASTEWATER INFLUENT FLOW</u>	<u>MAX STORAGE CAPACITIES</u>	<u>I/I & CLIMATE INPUTS</u>	<u>FUTURE FACILITY NEEDS</u>	<u>PERCOLATION INPUTS</u> <i>(FUTURE SITE STUDIES NEEDED FOR CONFIRMATION)</i>
ARSA Daily Average Wastewater Inflow 319,420 gpd	Henderson Reservoir 392.8 ac-ft Preston Reservoir 235.0 ac-ft Total System 627.8 ac-ft	I/I Reduction Factor 0.00% unitless 100-YR Multiplier 1.92 unitless Pan Evap Coefficient 0.75 unitless	MCSP/ARSA Additional LAA 0.0 Acres City of Lone Add'l Reservoir 0.0 ac-ft City of Lone Add'l LAA 0.0 Acres	Henderson/Preston Percolation Rate 0 ft/day 0 in./hr

No. Days	100-YEAR ANNUAL PRECIPITATION RETURN PERIOD													Water Year	AVERAGE ANNUAL PRECIPITATION RETURN PERIOD													Water Year
	31	30	31	31	28	31	30	31	30	31	31	30	31		31	30	31	31	28	31	30	31	30	31	31	30		
Units	October	November	December	January	February	March	April	May	June	July	August	September	Year	October	November	December	January	February	March	April	May	June	July	August	September	Year		
CLIMATE INPUTS																												
Precipitation - Calibrated & 2016/17 Distribution	in	5.98	2.42	5.10	14.28	4.48	3.21	3.88	0.50	1.21	0.00	0.02	0.02	41.11	1.20	3.47	3.50	3.83	3.10	3.01	2.06	0.47	0.15	0.10	0.19	0.33	21.41	
Precipitation - Calibrated & 2016/17 Distribution	in	5.98	2.42	5.10	14.28	4.48	3.21	3.88	0.50	1.21	0.00	0.02	0.02															
2016/2017 WY Precipitation	in	6.31	2.55	5.38	15.07	4.73	3.39	4.09	0.53	1.28	0.00	0.02	0.02	43.37														
Pan Evaporation	in	3.77	1.40	0.72	0.72	1.12	2.32	4.18	7.04	9.43	11.17	9.50	6.51	57.88	3.77	2.10	1.50	1.50	2.20	3.70	5.60	7.40	8.60	9.40	8.30	6.60	60.67	
Effective Water Surface Evaporation	in	2.83	0.79	0.41	0.41	0.63	1.31	3.14	5.28	7.07	8.38	7.13	4.88	42.23	2.83	1.05	0.54	0.54	0.84	1.74	3.14	5.28	7.07	8.38	7.13	4.88	43.41	
WASTEWATER GENERATION																												
Facility Wastewater Effluent (ADWF)	MG	9.9	9.6	9.9	9.9	8.9	9.9	9.6	9.9	9.6	9.9	9.9	9.6	116.6	9.9	9.6	9.9	9.9	8.9	9.9	9.6	9.9	9.6	9.9	9.6	9.9	116.6	
I/I Contributions - Calibrated	MG	6.7	3.1	7.3	18.8	6.5	4.9	5.8	1.2	1.9	0.7	0.7	0.7	58.5	1.9	4.2	5.3	5.7	4.8	4.7	3.5	1.2	0.9	0.8	0.9	1.1	34.9	
ARSA Wastewater Effluent	ac-ft	51.0	39.1	52.8	88.02	47.4	45.5	47.1	34.2	35.4	32.6	32.7	31.7	537.4	36.3	42.3	46.6	47.9	42.1	44.7	40.1	34.1	32.1	32.9	33.2	32.7	465.0	
ARSA 2016/2017 WY Effluent Flow Values	ac-ft	33.8	34.3	50.6	94.9	81.3	47.6	49.4	29.5	27.3	26.5	33.8	33.8	542.8														
MCSP Export Effluent (0.54 MGD ADWF)	ac-ft	0.0	0.0	0.0	0.00	0.0	0.0	0.0	5.5	5.5	5.5	5.5	5.5	27.6	0.0	0.0	0.0	0.0	0.0	0.0	0.0	0.0	0.0	0.0	0.0	0.0	0.0	
MCSP Export Effluent (0.67 MGD ADWF)	ac-ft	0.0	4.6	4.6	4.6	4.6	4.6	4.6	4.6	55.4	55.4	55.4	55.4	253.5	0.0	0.0	0.0	0.0	0.0	0.0	0.0	0.0	0.0	0.0	0.0	0.0	0.0	
WATERSHED CONTRIBUTING AREAS																												
Precipitation into Henderson Reservoir	ac-ft	14.4	5.8	12.3	34.4	10.8	7.7	9.3	1.2	2.9	0.0	0.0	0.0	98.9	2.9	8.4	8.4	9.2	7.5	7.2	5.0	1.1	0.4	0.2	0.5	0.8	51.5	
Run-off into Henderson Reservoir	ac-ft	2.2	0.9	1.8	5.2	1.6	1.2	1.4	0.2	0.4	0.0	0.0	0.0	14.8	0.4	1.3	1.3	1.4	1.1	1.1	0.7	0.2	0.1	0.0	0.1	0.1	7.7	
Precipitation into Preston Forebay	ac-ft	1.0	0.4	0.8	2.4	0.7	0.5	0.6	0.1	0.2	0.0	0.0	0.0	6.9	0.2	0.6	0.6	0.6	0.5	0.5	0.3	0.1	0.0	0.0	0.0	0.1	3.6	
Precipitation into Preston Reservoir	ac-ft	9.0	3.6	7.6	21.4	6.7	4.8	5.8	0.8	1.8	0.0	0.0	0.0	61.7	1.8	5.2	5.3	5.7	4.7	4.5	3.1	0.7	0.2	0.2	0.3	0.5	32.1	
Run-off into Preston Reservoir	ac-ft	7.0	2.8	6.0	16.8	5.3	3.8	4.6	0.6	1.4	0.0	0.0	0.0	48.3	1.4	4.1	4.1	4.5	3.6	3.5	2.4	0.6	0.2	0.1	0.2	0.4	25.2	
STORAGE RESERVOIRS																												
Henderson Reservoir Volume	ac-ft	27.5	78.8	123.7	190.1	317.0	375.4	392.8	392.8	334.7	243.3	133.8	43.9		27.5	36.3	87.4	143.2	200.9	250.2	299.8	300.4	237.9	141.7	37.3	27.5		
Henderson Reservoir Evaporation	ac-ft	-1.8	-0.8	-0.5	-0.7	-1.4	-3.1	-7.5	-12.6	-15.9	-16.2	-9.7	-3.7	-73.8	-1.8	-0.7	-0.6	-0.8	-1.5	-3.4	-6.7	-11.4	-13.5	-11.8	-5.0	-3.0	-60.2	
Henderson Reservoir Percolation	ac-ft	0.0	0.0	0.0	0.0	0.0	0.0	0.0	0.0	0.0	0.0	0.0	0.0	0.0	0.0	0.0	0.0	0.0	0.0	0.0	0.0	0.0	0.0	0.0	0.0	0.0	0.0	
Preston Forebay Evaporation	ac-ft	0.0	-0.1	-0.1	-0.1	-0.1	-0.2	-0.5	-0.9	-1.2	-1.4	-1.2	-0.8	-6.6	-0.5	-0.2	-0.1	-0.1	-0.1	-0.3	-0.5	-0.9	-1.2	-1.4	-1.2	-0.8	-7.2	
Preston Forebay Percolation	ac-ft	0.0	0.0	0.0	0.0	0.0	0.0	0.0	0.0	0.0	0.0	0.0	0.0	0.0	0.0	0.0	0.0	0.0	0.0	0.0	0.0	0.0	0.0	0.0	0.0	0.0	0.0	
Preston Reservoir COWRF Emergency Storage	ac-ft	8.0	0.0	0.0	0.0	0.0	0.0	8.0	40.0	60.0	64.0	58.0	40.0		18.0	0.0	0.0	0.0	0.0	0.0	24.0	46.0	62.0	66.0	58.0	44.0		
Preston Reservoir Max Usable Storage	ac-ft	227.0	235.0	235.0	235.0	235.0	227.0	195.0	175.0	171.0	177.0	195.0			217.0	235.0	235.0	235.0	235.0	235.0	211.0	189.0	173.0	169.0	177.0	191.0		
Preston Reservoir Volume	ac-ft	0.0	17.0	28.1	46.9	91.8	108.4	154.6	202.0	199.8	247.7	289.6	333.5		349.3	348.2	356.3	365.4	375.4	382.9	388.6	389.4	382.2	371.2	357.9	271.3		
Preston Excess Storage Volume	ac-ft	0.0	0.0	0.0	0.0	0.0	0.0	7.0	24.8	76.7	112.6	138.5		132.3	113.2	121.3	130.4	140.4	147.9	177.6	200.4	209.2	202.2	180.9	80.3			
Preston Reservoir Evaporation	ac-ft	0.0	-0.2	-0.2	-0.2	-0.6	-1.3	-3.8	-7.3	-9.7	-12.2	-10.3	-7.1	-52.9	-4.1	-1.5	-0.8	-0.8	-1.2	-2.5	-4.6	-7.7	-10.3	-12.2	-10.3	-7.1	-63.0	
Preston Reservoir Percolation	ac-ft	0.0	0.0	0.0	0.0	0.0	0.0	0.0	0.0	0.0	0.0	0.0	0.0	0.0	0.0	0.0	0.0	0.0	0.0	0.0	0.0	0.0	0.0	0.0	0.0	0.0	0.0	
Combined System Total Beginning Water Storage	ac-ft	27.5	95.8	151.8	237.0	408.7	483.8	547.4	594.8	534.4	491.0	423.4	377.4		376.8	384.4	443.8	508.6	576.3	633.0	688.4	689.8	620.1	512.9	395.2	298.8		
Combined System Total Reservoir Evaporation	ac-ft	-1.8	-1.2	-0.8	-1.0	-2.0	-4.6	-11.8	-20.8	-26.8	-29.8	-21.3	-11.6	-133.3	-6.3	-2.4	-1.4	-1.6	-2.8	-6.2	-11.8	-19.9	-25.0	-25.4	-16.5	-10.9	-130.4	
Combined System Total Reservoir Percolation	ac-ft	0.0	0.0	0.0	0.0	0.0	0.0	0.0	0.0	0.0	0.0	0.0	0.0	0.0	0.0	0.0	0.0	0.0	0.0	0.0	0.0	0.0	0.0	0.0	0.0	0.0	0.0	
LAND APPLICATION DISPOSAL DEMANDS																												
Bowers' Ranch	ac-ft	0.0	0.0	0.0	0.0	0.0	0.0	0.0	0.0	0.0	0.0	0.0	0.0	0.0	0.0	0.0	0.0	0.0	0.0	0.0	0.0	0.0	0.0	0.0	0.0	0.0	0.0	
2016/2017 WY Bower's Ranch	ac-ft	-7.7	0	0	0	0	0	0	0	-24.6	-26.7	-26.7	-26.7	-112.4														
Hoskins' Ranch	ac-ft	-3.3	0.0	0.0	0.0	0.0	0.0	-2.3	-19.4	-24.7	-26.0	-23.5	-16.4	-115.5	-1.8	0.0	0.0	0.0	0.0	0.0	-3.2	-16.4	-22.8	-24.9	-23.1	-14.6	-106.7	
2016/2017 WY Hoskin's Ranch	ac-ft	0	0	0	0	0	0	0	-8.3	-27	-32.8	-26.4	-36.5	-131.0														
COWRF and Castle Oaks Golf Course	ac-ft	-11.3	0.0	0.0	0.0	0.0	0.0	-11.9	-61.7	-89.4	-99.9	-89.4	-59.9	-423.4	-27.3	0.0	0.0	0.0	0.0	0.0	-35.3	-70.1	-92.4	-100.9	-91.1	-64.6	-481.7	
ARSA Additional LAA Disposal	ac-ft	0.0	0.0	0.0	0.0	0.0	0.0	0.0	0.0	0.0	0.0	0.0	0.0	0.0	0.0	0.0	0.0	0.0	0.0	0.0	0.0	0.0	0.0	0.0	0.0	0.0	0.0	
MONTHLY STORAGE BALANCE																												
Total Inflows (excluding Unmet Irrigation Demands)	ac-ft	84.5	57.2	85.9	172.7	77.2	68.1	73.4	41.5	97.6	88.0	88.2	87.2	1021.5	43.0	61.8	66.3	69.4	59.5	61.6	51.7	36.7	32.9	33.5	34.3	34.5	585.1	
Total Inflows (including Unmet Irrigation Demands)	ac-ft	84.5	57.2	85.9	172.7	77.2	68.1	73.4	41.5	97.6	88.0	88.2	87.2	1021.5	43.0	61.8	66.3	69.4	59.5	61.6	51.7	36.7	32.9	33.5	34.3	34.5	585.1	
Total Outflows	ac-ft	-16.3	-1.2	-0.7	-1.0	-2.0	-4.6	-26.0	-101.9	-141.0	-155.6	-134.2	-87.8	-672.2	-35.4	-2.4	-1.4	-1.6	-2.8	-6.2	-50.3	-106.4	-140.1	-151.2	-130.7	-90.2	-718.9	
Beginning Storage Volume	ac-ft	27.5	95.8	151.8	237.0	408.7	483.8	547.4	594.8	534.4	491.0	423.4	377.4		376.8	384.4	443.8	508.6	576.3	633.0	688.4	689.8	620.1	512.9	395.2	298.8		
Change in Water Volume	ac-ft	68.3	56.0	85.2	171.8	75.1	63.5	47.4	-60.3	-43.4	-67.6	-46.0	-0.6		7.6	59.3	64.8	67.7	56.7	55.4	1.4	-69.7	-107.2	-117.7	-96.4	-55.7		
Final Storage Volume	ac-ft	95.8	151.8	237.0	408.7	483.8	547.4	594.8	534.4	491.0	423.4	377.4	376.8		384.4	443.8	508.6	576.3	633.0	688.4	689.8	620.1	512.9	395.2	298.8	243.1		

ARSA Maximum Seasonal Storage Used (ac-ft) **594.8** 193.8 Mgal
Henderson Unutilized Capacity (ac-ft) **0.0** 0.0 Mgal
Preston Unutilized Capacity (ac-ft) **-138.5** -45.1 Mgal

ARSA Maximum Seasonal Storage Used (ac-ft) **689.8** 224.8 Mgal
Henderson Unutilized Capacity (ac-ft) **92.4** 30.1 Mgal
Preston Unutilized Capacity (ac-ft) **-209.2** -68.2 Mgal
Excess Effluent Volume (ac-ft) **215.6** 70.2 Mgal

ARSA, COWRF/COGC, and MCSP Combined Water Balance Update
Scenario 1a: MCSP ADWF 0.54 MGD - Hypothetical Required Percolation Rate to Achieve Balance
Future Flows & Facilities, Calibrated at 2016/17 Rainfall Distribution
 August 2025 By: Bill Slenter/Steven Whittlesey, HydroScience

<u>WASTEWATER INFLUENT FLOW</u>	<u>MAX STORAGE CAPACITIES</u>	<u>I/I & CLIMATE INPUTS</u>	<u>FUTURE FACILITY NEEDS</u>	<u>PERCOLATION INPUTS</u> <i>(FUTURE SITE STUDIES NEEDED FOR CONFIRMATION)</i>
ARSA Daily Average Wastewater Influent Flow 319,420 gpd	Henderson Reservoir 392.8 ac-ft Preston Reservoir 235.0 ac-ft Total System 627.8 ac-ft	I/I Reduction Factor 0.00% unitless 100-YR Multiplier 1.92 unitless Pan Evap Coefficient 0.75 unitless	MCSP/ARSA Additional LAA 0.0 Acres City of Lone Add'l Reservoir 0.0 ac-ft City of Lone Add'l LAA 0.0 Acres	Henderson/Preston Percolation Rate 0.00192 ft/day 6.67E-06 in./hr

No. Days	100-YEAR ANNUAL PRECIPITATION RETURN PERIOD													Water Year	AVERAGE ANNUAL PRECIPITATION RETURN PERIOD													Water Year
	31	30	31	31	28	31	30	31	30	31	31	30	31		31	30	31	31	28	31	30	31	30	31	31	30		
Units	October	November	December	January	February	March	April	May	June	July	August	September	Year	October	November	December	January	February	March	April	May	June	July	August	September	Year		
CLIMATE INPUTS																												
Precipitation - Calibrated & 2016/17 Distribution	in	5.98	2.42	5.10	14.28	4.48	3.21	3.88	0.50	1.21	0.00	0.02	0.02	41.11	1.20	3.47	3.50	3.83	3.10	3.01	2.06	0.47	0.15	0.10	0.19	0.33	21.41	
Precipitation - Calibrated & 2016/17 Distribution	in	5.98	2.42	5.10	14.28	4.48	3.21	3.88	0.50	1.21	0.00	0.02	0.02															
2016/2017 WY Precipitation	in	6.31	2.55	5.38	15.07	4.73	3.39	4.09	0.53	1.28	0.00	0.02	0.02	43.37														
Pan Evaporation	in	3.77	1.40	0.72	0.72	1.12	2.32	4.18	7.04	9.43	11.17	9.50	6.51	57.88	3.77	2.10	1.50	1.50	2.20	3.70	5.60	7.40	8.60	9.40	8.30	6.60	60.67	
Effective Water Surface Evaporation	in	2.83	0.79	0.41	0.41	0.63	1.31	3.14	5.28	7.07	8.38	7.13	4.88	42.23	2.83	1.05	0.54	0.54	0.84	1.74	3.14	5.28	7.07	8.38	7.13	4.88	43.41	
WASTEWATER GENERATION																												
Facility Wastewater Effluent (ADWF)	MG	9.9	9.6	9.9	9.9	8.9	9.9	9.6	9.9	9.6	9.9	9.6	9.9	116.6	9.9	9.6	9.9	9.9	8.9	9.9	9.6	9.9	9.6	9.9	9.6	9.9	116.6	
I/I Contributions - Calibrated	MG	6.7	3.1	7.3	18.8	6.5	4.9	5.8	1.2	1.9	0.7	0.7	0.7	58.5	1.9	4.2	5.3	5.7	4.8	4.7	3.5	1.2	0.9	0.8	0.9	1.1	34.9	
ARSA Wastewater Effluent	ac-ft	51.0	39.1	52.8	88.02	47.4	45.5	47.1	34.2	35.4	32.6	32.7	31.7	537.4	36.3	42.3	46.6	47.9	42.1	44.7	40.1	34.1	32.1	32.9	33.2	32.7	465.0	
ARSA 2016/2017 WY Effluent Flow Values	ac-ft	33.8	34.3	50.6	94.9	81.3	47.6	49.4	29.5	27.3	26.5	33.8	33.8	542.8														
MCSP Export Effluent (0.54 MGD ADWF)	ac-ft	0.0	0.0	0.0	0.00	0.0	0.0	0.0	5.5	5.5	5.5	5.5	5.5	27.6	0.0	0.0	0.0	0.0	0.0	0.0	0.0	0.0	0.0	0.0	0.0	0.0	0.0	
MCSP Export Effluent (0.67 MGD ADWF)	ac-ft	0.0	4.6	4.6	4.6	4.6	4.6	4.6	4.6	55.4	55.4	55.4	55.4	253.5	0.0	0.0	0.0	0.0	0.0	0.0	0.0	0.0	0.0	0.0	0.0	0.0	0.0	
WATERSHED CONTRIBUTING AREAS																												
Precipitation into Henderson Reservoir	ac-ft	14.4	5.8	12.3	34.4	10.8	7.7	9.3	1.2	2.9	0.0	0.0	0.0	98.9	2.9	8.4	8.4	9.2	7.5	7.2	5.0	1.1	0.4	0.2	0.5	0.8	51.5	
Run-off into Henderson Reservoir	ac-ft	2.2	0.9	1.8	5.2	1.6	1.2	1.4	0.2	0.4	0.0	0.0	0.0	14.8	0.4	1.3	1.3	1.4	1.1	1.1	0.7	0.2	0.1	0.0	0.1	0.1	7.7	
Precipitation into Preston Forebay	ac-ft	1.0	0.4	0.8	2.4	0.7	0.5	0.6	0.1	0.2	0.0	0.0	0.0	6.9	0.2	0.6	0.6	0.6	0.5	0.5	0.3	0.1	0.0	0.0	0.0	0.1	3.6	
Precipitation into Preston Reservoir	ac-ft	9.0	3.6	7.6	21.4	6.7	4.8	5.8	0.8	1.8	0.0	0.0	0.0	61.7	1.8	5.2	5.3	5.7	4.7	4.5	3.1	0.7	0.2	0.2	0.3	0.5	32.1	
Run-off into Preston Reservoir	ac-ft	7.0	2.8	6.0	16.8	5.3	3.8	4.6	0.6	1.4	0.0	0.0	0.0	48.3	1.4	4.1	4.1	4.5	3.6	3.5	2.4	0.6	0.2	0.1	0.2	0.4	25.2	
STORAGE RESERVOIRS																												
Henderson Reservoir Volume	ac-ft	27.5	78.3	122.6	188.0	313.7	370.8	392.8	392.8	333.0	240.1	129.4	38.7		27.5	35.8	86.5	141.5	198.2	246.4	294.7	293.8	229.9	132.7	27.8	27.5		
Henderson Reservoir Evaporation	ac-ft	-1.8	-0.8	-0.5	-0.7	-1.4	-3.1	-7.5	-12.6	-15.9	-16.1	-9.5	-3.5	-73.3	-1.8	-0.7	-0.6	-0.8	-1.4	-3.4	-6.7	-11.2	-13.3	-11.4	-4.5	-3.0	-58.7	
Henderson Reservoir Percolation	ac-ft	-0.4	-0.7	-0.9	-1.2	-1.4	-1.7	-1.6	-1.7	-1.6	-1.4	-1.0	-0.5	-14.1	-0.4	-0.5	-0.8	-1.0	-1.1	-1.4	-1.5	-1.5	-1.3	-1.0	-0.4	-0.4	-11.3	
Preston Forebay Evaporation	ac-ft	0.0	-0.1	-0.1	-0.1	-0.1	-0.2	-0.5	-0.9	-1.2	-1.4	-1.2	-0.8	-6.6	-0.5	-0.2	-0.1	-0.1	-0.1	-0.3	-0.5	-0.9	-1.2	-1.4	-1.2	-0.8	-7.2	
Preston Forebay Percolation	ac-ft	0.0	-0.1	-0.1	-0.1	-0.1	-0.1	-0.1	-0.1	-0.1	-0.1	-0.1	-0.1	-1.3	-0.1	-0.1	-0.1	-0.1	-0.1	-0.1	-0.1	-0.1	-0.1	-0.1	-0.1	-0.1	-1.4	
Preston Reservoir COWRF Emergency Storage	ac-ft	8.0	0.0	0.0	0.0	0.0	0.0	8.0	40.0	60.0	64.0	58.0	40.0		18.0	0.0	0.0	0.0	0.0	0.0	24.0	46.0	62.0	66.0	58.0	44.0		
Preston Reservoir Max Usable Storage	ac-ft	227.0	235.0	235.0	235.0	235.0	235.0	227.0	195.0	175.0	171.0	177.0	195.0		217.0	235.0	235.0	235.0	235.0	235.0	211.0	189.0	173.0	169.0	177.0	191.0		
Preston Reservoir Volume	ac-ft	0.0	17.4	24.3	39.1	80.2	93.1	129.5	171.8	171.8	171.0	164.8	160.2		121.1	120.7	128.9	138.0	148.3	156.2	162.8	164.7	159.0	149.9	138.8	44.5		
Preston Excess Storage Volume	ac-ft	0.0	0.0	0.0	0.0	0.0	0.0	0.0	0.0	0.0	0.0	0.0	0.0	0.0	0.0	0.0	0.0	0.0	0.0	0.0	0.0	0.0	0.0	0.0	0.0	0.0		
Preston Reservoir Evaporation	ac-ft	0.0	-0.2	-0.1	-0.2	-0.5	-1.2	-3.4	-6.8	-9.1	-10.7	-8.9	-6.0	-47.2	-3.0	-1.1	-0.6	-0.6	-1.0	-2.1	-3.9	-6.6	-8.7	-10.0	-8.1	-2.6	-48.4	
Preston Reservoir Percolation	ac-ft	0.0	-0.2	-0.3	-0.4	-0.5	-0.6	-0.8	-0.9	-0.9	-0.9	-0.9	-0.9		-0.8	-0.7	-0.8	-0.8	-0.8	-0.9	-0.9	-0.9	-0.9	-0.9	-0.9	-0.9	-0.4	
Combined System Total Beginning Water Storage	ac-ft	27.5	95.8	146.9	227.1	393.9	463.9	522.3	564.6	504.7	411.1	294.1	198.9		148.6	156.5	215.4	279.5	346.5	402.6	457.4	458.5	389.0	282.6	166.6	71.9		
Combined System Total Reservoir Evaporation	ac-ft	-1.8	-1.2	-0.7	-0.9	-2.0	-4.4	-11.4	-20.2	-26.2	-28.2	-19.7	-10.3	-127.1	-5.2	-2.0	-1.3	-1.5	-2.6	-5.8	-11.1	-18.7	-23.2	-22.8	-13.8	-6.5	-114.4	
Combined System Total Reservoir Percolation	ac-ft	-0.4	-1.0	-1.3	-1.7	-2.0	-2.4	-2.5	-2.7	-2.6	-2.4	-2.0	-1.5	-22.6	-1.3	-1.3	-1.7	-1.9	-2.0	-2.4	-2.5	-2.5	-2.3	-1.9	-1.4	-0.9	-22.1	
LAND APPLICATION DISPOSAL DEMANDS																												
Bowers' Ranch	ac-ft	0.0	0.0	0.0	0.0	0.0	0.0	0.0	0.0	0.0	0.0	0.0	0.0	0.0	0.0	0.0	0.0	0.0	0.0	0.0	0.0	0.0	0.0	0.0	0.0	0.0	0.0	
2016/2017 WY Bower's Ranch	ac-ft	-7.7	0	0	0	0	0	0	0	-24.6	-26.7	-26.7	-26.7	-112.4														
Hoskins' Ranch	ac-ft	-3.3	0.0	0.0	0.0	0.0	0.0	-2.3	-19.4	-24.7	-26.0	-23.5	-16.4	-115.5	-1.8	0.0	0.0	0.0	0.0	0.0	-3.2	-16.4	-22.8	-24.9	-23.1	-14.6	-106.7	
2016/2017 WY Hoskin's Ranch	ac-ft	0	0	0	0	0	0	0	-8.3	-27	-32.8	-26.4	-36.5	-131.0														
COWRF and Castle Oaks Golf Course	ac-ft	-11.3	0.0	0.0	0.0	0.0	0.0	-11.9	-61.7	-89.4	-99.9	-89.4	-59.9	-423.4	-27.3	0.0	0.0	0.0	0.0	0.0	-35.3	-70.1	-92.4	-100.9	-91.1	-64.6	-481.7	
Additional LAA Disposal	ac-ft	0.0	0.0	0.0	0.0	0.0	0.0	0.0	0.0	0.0	0.0	0.0	0.0	0.0	0.0	0.0	0.0	0.0	0.0	0.0	0.0	0.0	0.0	0.0	0.0	0.0	0.0	
MONTHLY STORAGE BALANCE																												
Total Inflows (excluding Unmet Irrigation Demands)	ac-ft	84.5	52.6	81.4	168.2	72.6	63.5	68.8	42.5	47.7	38.1	38.3	37.3	795.6	43.0	61.8	66.3	69.4	59.5	61.6	51.7	36.7	32.9	33.5	34.3	34.5	585.1	
Total Inflows (including Unmet Irrigation Demands)	ac-ft	84.5	52.6	81.4	168.2	72.6	63.5	68.8	42.5	47.7	38.1	38.3	37.3	795.6	43.0	61.8	66.3	69.4	59.5	61.6	51.7	36.7	32.9	33.5	34.3	42.2	592.8	
Total Outflows	ac-ft	-16.7	-2.2	-2.0	-2.6	-4.0	-6.9	-28.2	-104.1	-142.9	-156.5	-134.5	-88.0	-688.6	-35.6	-3.3	-2.9	-3.4	-4.6	-8.2	-52.0	-107.8	-140.6	-150.5	-129.3	-86.6	-724.9	
Beginning Storage Volume	ac-ft	27.5	95.8	146.9	227.1	393.9	463.9	522.3	564.6	504.7	411.1	294.1	198.9		148.6	156.5	215.4	279.5	346.5	402.6	457.4	458.5	389.0	282.6	166.6	71.9		
Change in Water Volume	ac-ft	67.8	50.4	79.3	165.6	68.6	56.7	40.7	-61.6	-95.2	-118.4	-96.2	-50.7		7.4	58.5	63.4	66.0	55.0	53.4	-0.4	-71.1	-107.7	-117.0	-95.1	-44.5		
Final Storage Volume	ac-ft	95.3	146.2	226.2	392.7	462.5	520.6	562.9	503.0	409.6	292.8	197.9	148.1		156.1	215.0	278.8	345.5	401.5	456.0	457.1	387.4	281.3	165.6	71.5	27.5		

ARSA Maximum Seasonal Storage Used (ac-ft) **562.9** 183.4 Mgal
 Henderson Unutilized Capacity (ac-ft) **0.0** 0.0 Mgal
 Preston Unutilized Capacity (ac-ft) **0.0** 0.0 Mgal

ARSA Maximum Seasonal Storage Used (ac-ft) **457.1** 148.9 Mgal
 Henderson Unutilized Capacity (ac-ft) **98.1** 32.0 Mgal
 Preston Unutilized Capacity (ac-ft) **14.0** 4.6 Mgal
 Excess Effluent Volume (ac-ft) **0.0** 0.0 Mgal