



CHANGE ORDER REQUEST SUMMARY

CHANGE ORDER REQUEST #: 107

DATE: 7/15/2024

DESCRIPTION : REVISED PR #02 Shooting Range Lighting Controls

PROJECT : Spring Lake Park City Hall Renovation / Expansion

C.R.C. PROJECT : 7088

	Supervision and Project Management	PR #02 Shooting Range Lighting Controls						TOTALS	RATE	COST
LABOR (MAN-HOURS) :										
LABORER								0.000	\$98.00	\$0.00
LABORER - OVERTIME								0.000	\$147.00	\$0.00
CARPENTER								0.000	\$105.00	\$0.00
CARPENTER - OVERTIME								0.000	\$157.50	\$0.00
SUPERINTENDENT	1.00							1.000	\$150.00	\$150.00
PROJECT MANAGER	1.00							1.000	\$150.00	\$150.00
MATERIALS & EQUIPMENT :										
										\$0.00
										\$0.00
										\$0.00
										\$0.00
										\$0.00
SUBCONTRACTORS :										
										\$0.00
Retrofit Electric		\$ 833.88								\$833.88
										\$0.00
										\$0.00
										\$0.00
										\$0.00

SUBTOTAL =	\$1,133.88
10% OVERHEAD & FEE =	\$30.00
5% OVERHEAD & FEE =	\$41.69
BOND COST =	\$22.91
TOTAL =	\$1,228.48

Proposal Request



PROJECT: Spring Lake Park City Hall Renovation/
Expansion Project
1301 81st Avenue NE
Spring Lake Park, MN 55432

PROPOSAL REQUEST NO: 2
DATE: 4/11/2024
PROJECT NO: 193806049
CONTRACT FOR: Building Construction

OWNER: City of Spring Lake Park, MN

TO: Jason Haraldson
Construction Results Corporation
5465 Hwy 169 North
Plymouth, MN 55442

Please submit an itemized quotation for changes in the Contract Sum and/or Time incidental to proposed modifications to the Contract Documents described herein. Your quotation shall be provided to this office at the earliest possible date but no later than 10 days after date listed above to allow for review without impacting the project construction schedule. The quotation and supporting documents can be mailed to my attention at Stantec Consulting Services, Inc., 733 Marquette Avenue, Suite 1000, Minneapolis, MN 55402, or emailed to me at bruce.paulson@stantec.com . Please contact me with any questions at (612) 712-2108.

THIS IS NOT A CHANGE ORDER NOR A DIRECTION TO PROCEED WITH THE WORK DESCRIBED HEREIN.

Written Description of the Work

ITEM NO. 1: Shooting Range Lighting Controls Clarification

Sheet E701 (Issued):

1. Add Police Light Wiring Diagram G as indicated.

Attachments:

1. E701

END OF PROPOSAL REQUEST

ARCHITECT: BRUCE P. PAULSON

THE CONTRACTOR SHALL VERIFY AND BE RESPONSIBLE FOR ALL DIMENSIONS. DO NOT SCALE THE DRAWING. ALL DIMENSIONS SHALL BE TO FACE UNLESS NOTED OTHERWISE. REPRODUCTION OF THIS DRAWING WITHOUT THE WRITTEN PERMISSION OF STANTEC IS PROHIBITED.

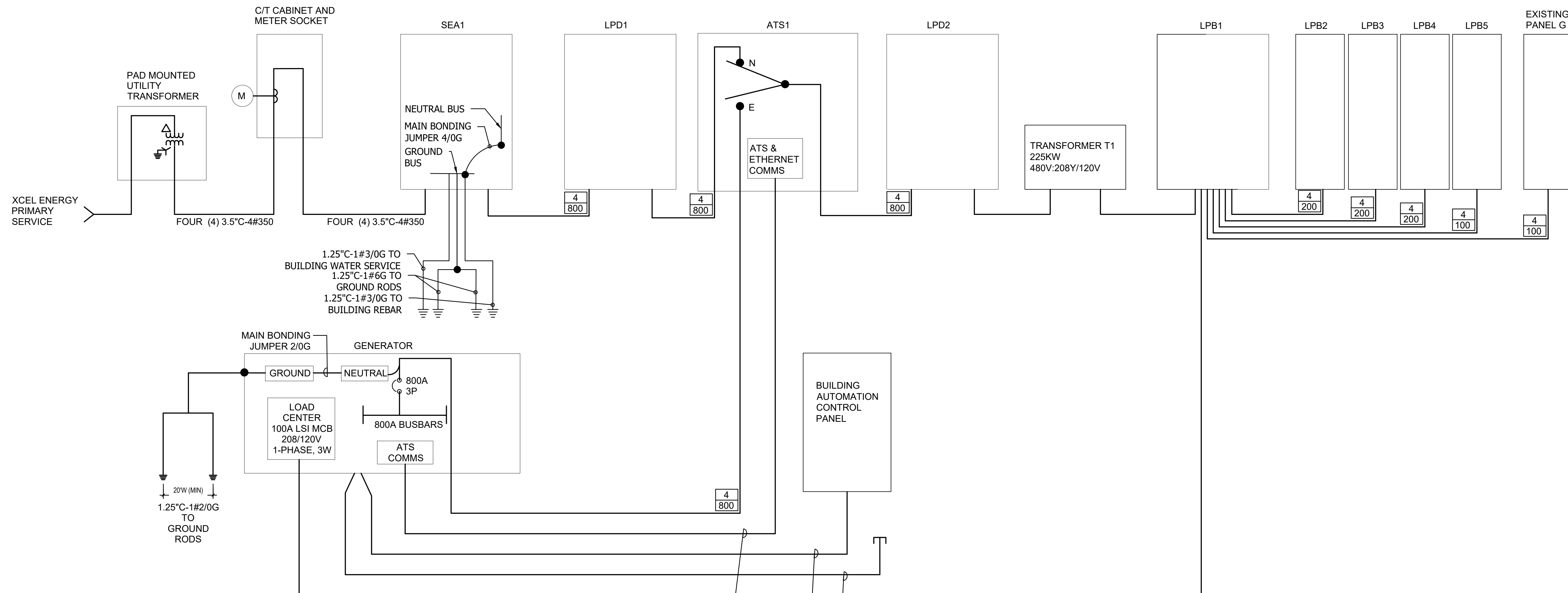

ATS ETHERNET COMMS START SIGNAL & REMOTE EMERGENCY STOP CABLING IN 1.5\"/>

PROVIDE 1.5\"/>

PROVIDE SPARE 1.5\"/>

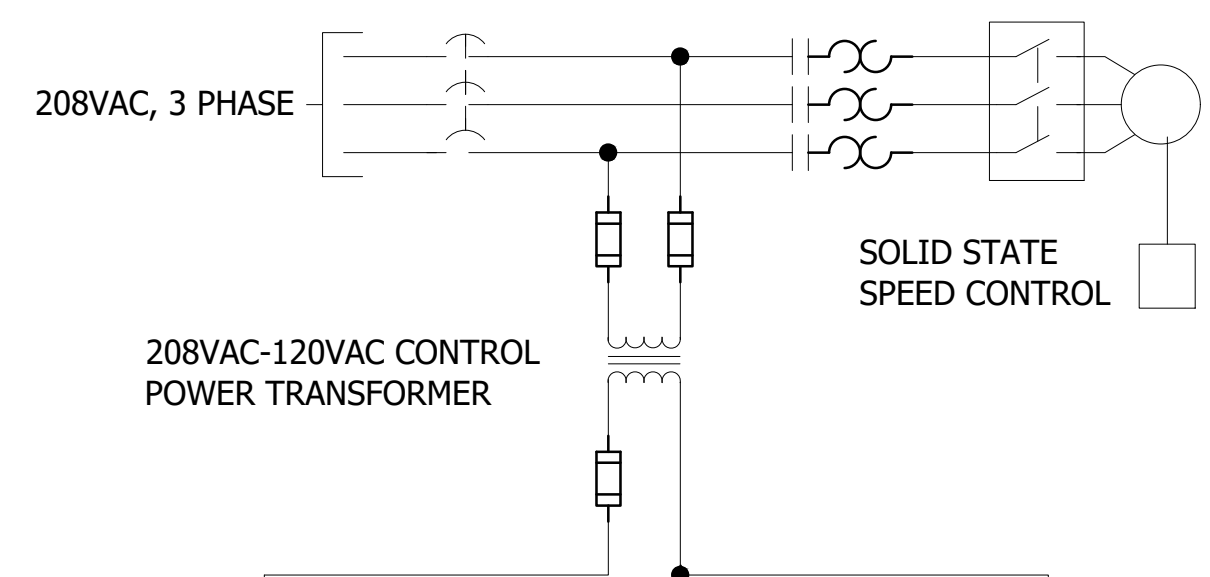

A LINE DIAGRAM
NO SCALE

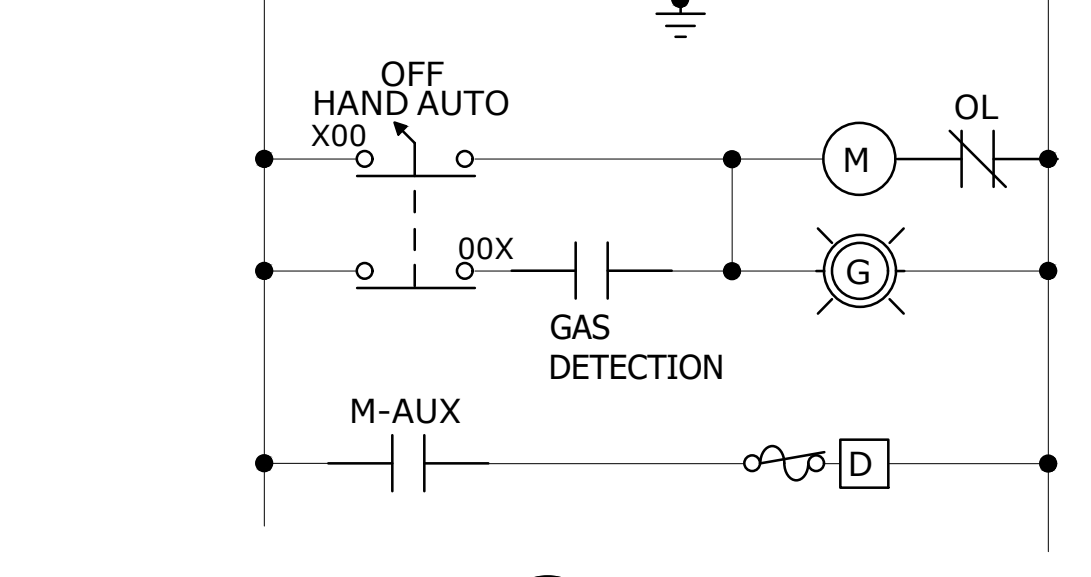

B EF 1 WIRING DIAGRAM
NO SCALE

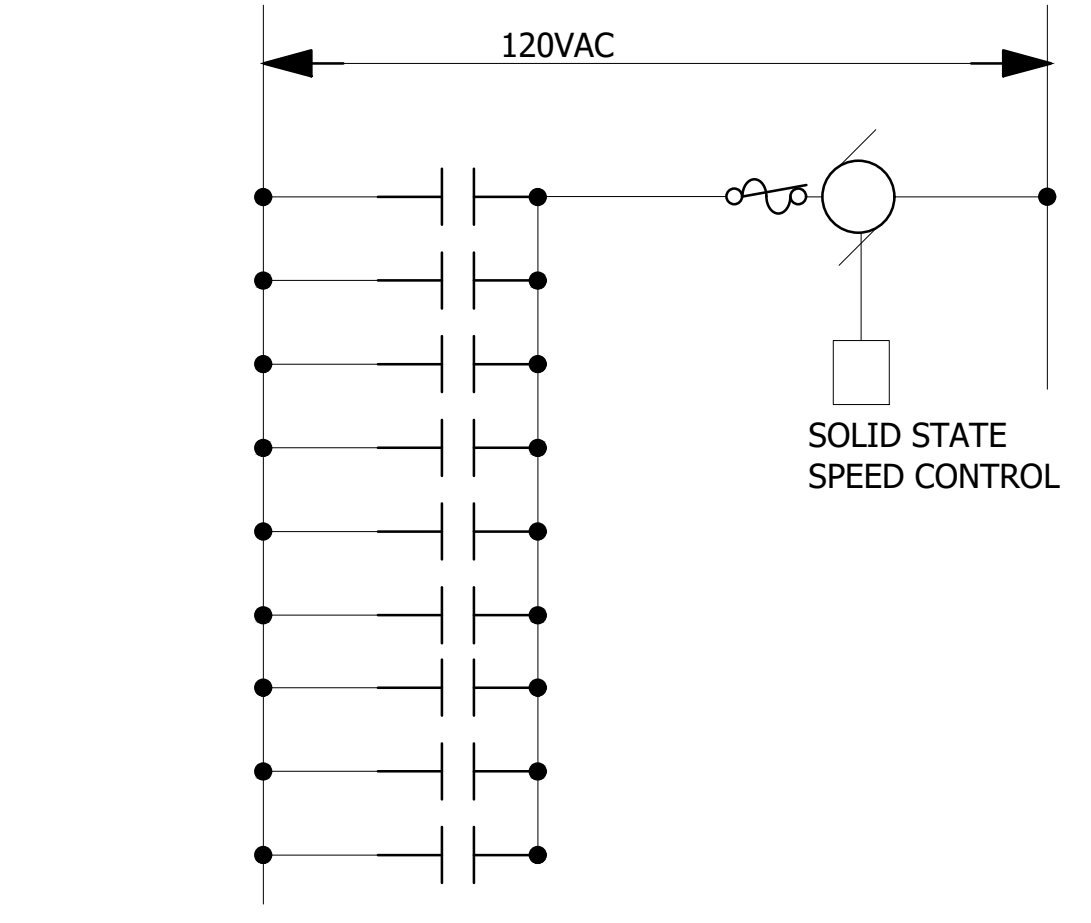

C EF 2 WIRING DIAGRAM
NO SCALE

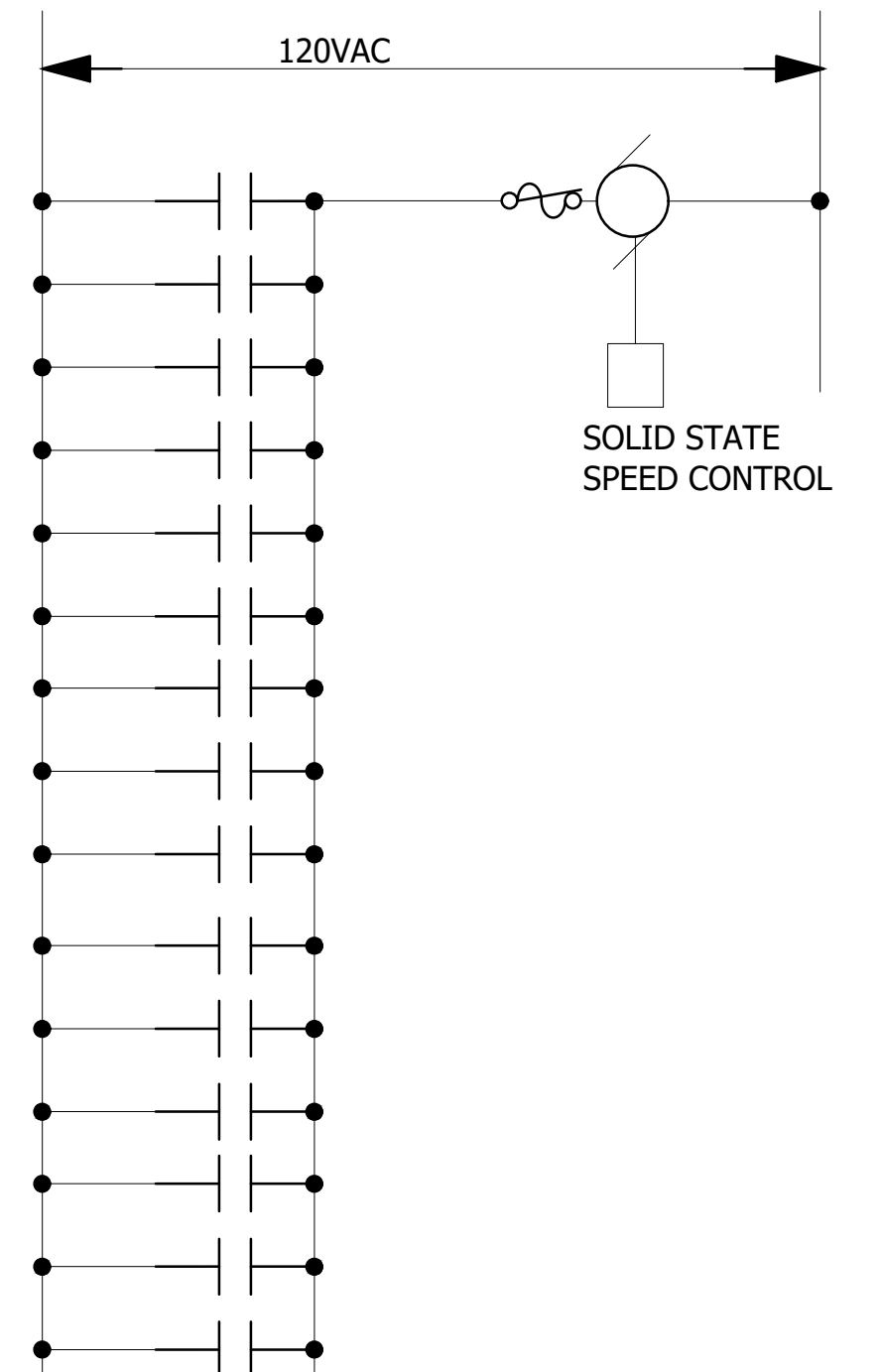

D EF 3 WIRING DIAGRAM
NO SCALE

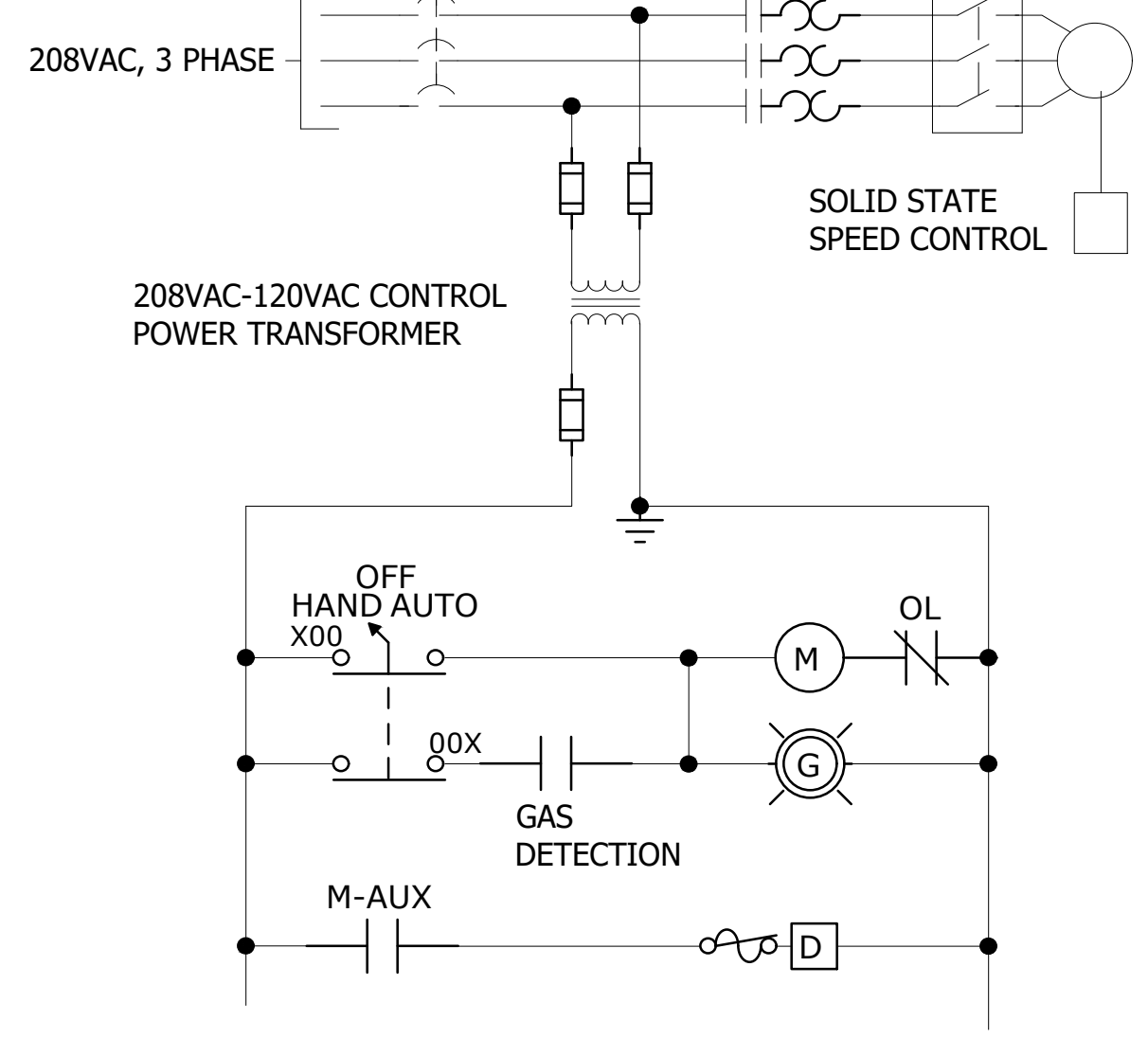

E EF 4 WIRING DIAGRAM
NO SCALE

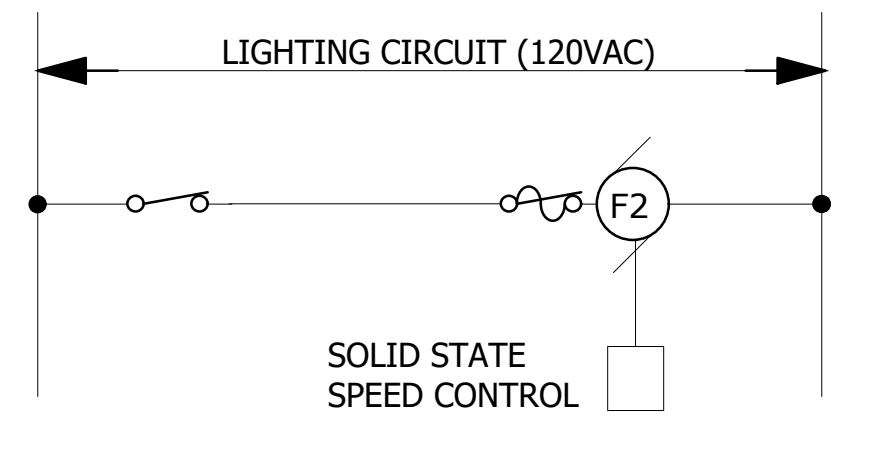

F EF 5 WIRING DIAGRAM
NO SCALE

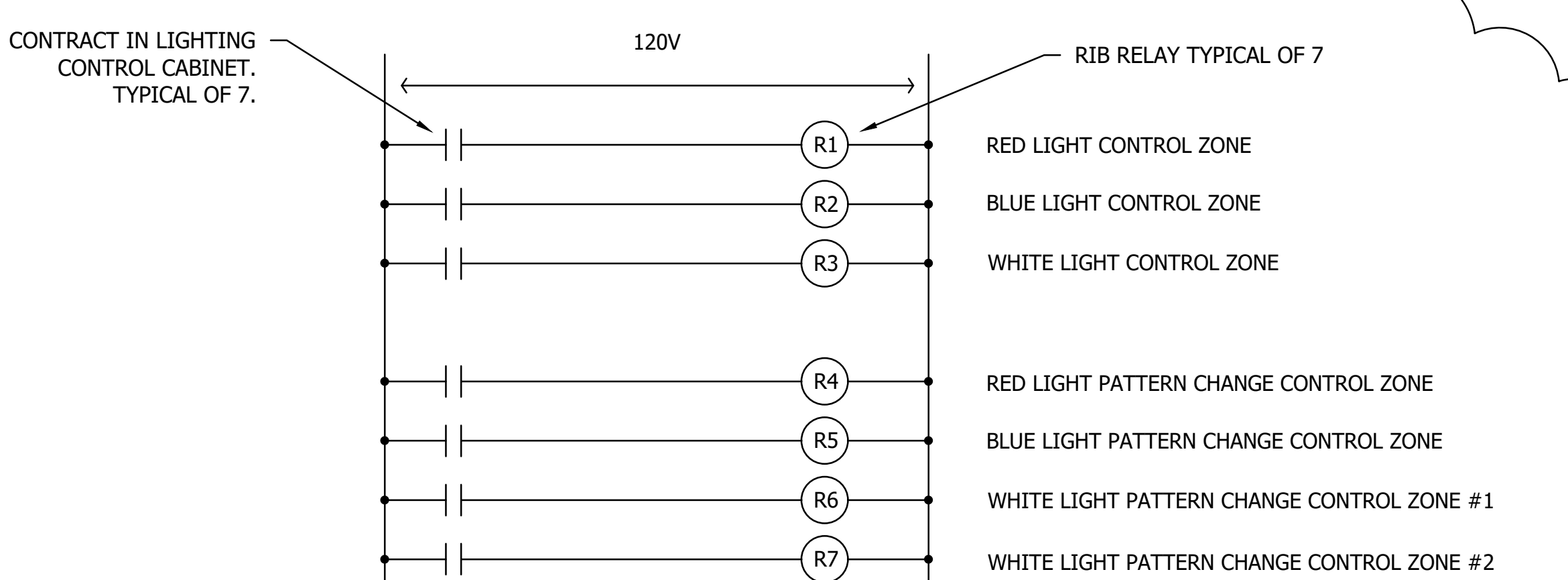

G POLICE LIGHT WIRING DIAGRAM
NO SCALE

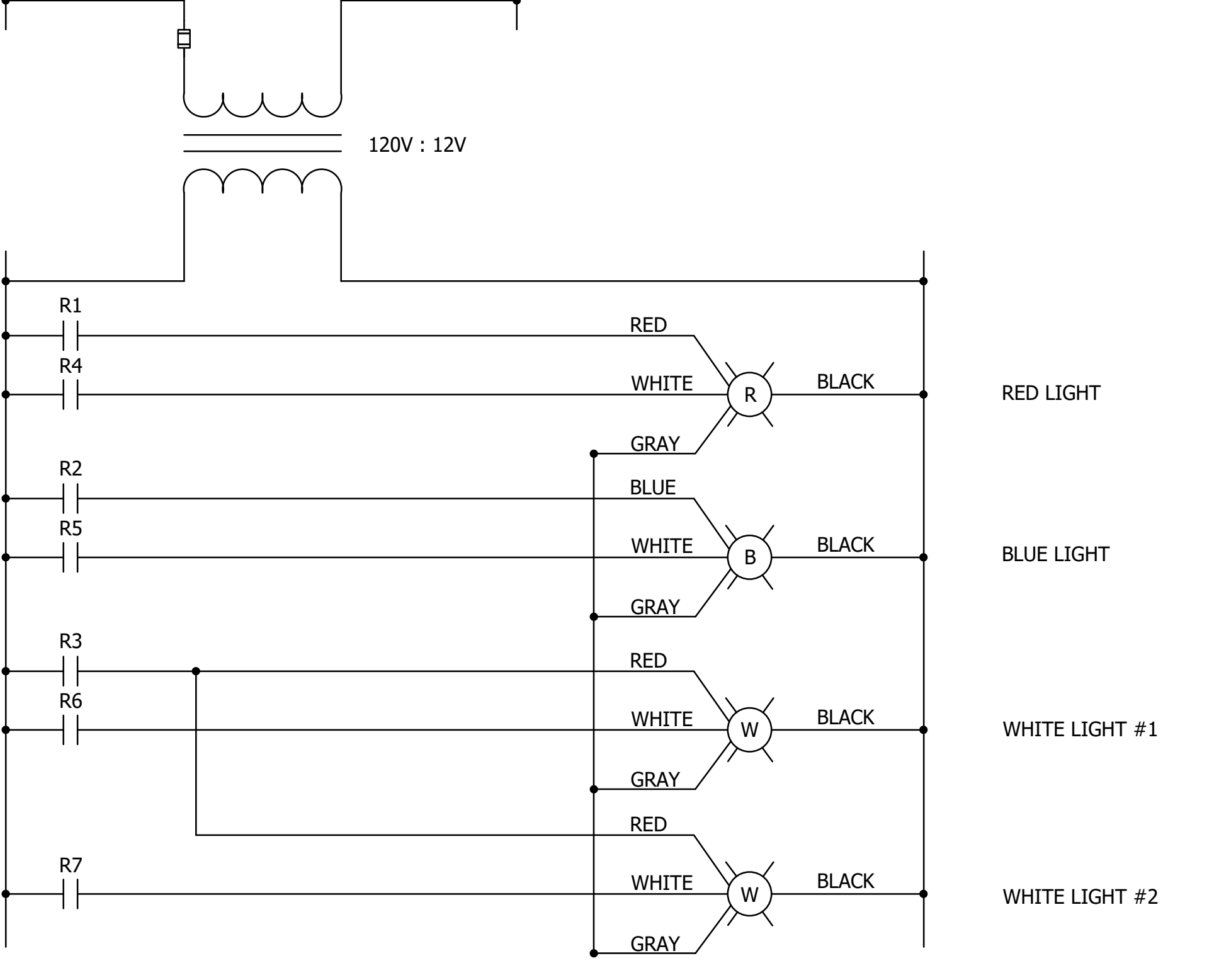

Per Date: 04/11/2024 1:54pm
User: jshelton
Project: 19385649-CAD (Dwg)
Source: 19385649-R10.dwg
Scale: X 1/2 X3 X4 X5 X6 X7

REGISTERED PROFESSIONAL ENGINEER
IN THE STATE OF MINNESOTA
AND THAT I AM A DULY LICENSED PROFESSIONAL ENGINEER
UNDER THE LAWS OF THE STATE OF MINNESOTA.
PRINT NAME: MICHAEL J. EBERHART
SIGNATURE: *Michael J. Eberhart*
DATE: 03/06/2024 10:00:00 License No. 19385649

CITY OF SPRING LAKE PARK, MINNESOTA
CITY HALL RENOVATION/EXPANSION
LINE DIAGRAMS

NO	REVISION	DATE
1	PR 2	4/11/2024

SURVEY	DRAWN	DESIGNED	CHECKED	APPROVED
	KSL	KSL	MFT	MFT

PROJ. NO. 19385649
SHEET NUMBER
E701

Prepared For
Construction Results

Dan Knutson
612-756-2307-
dknutson@retrofitcompanies.com

SLP City Hall-REVISED PR#2

7/15/2024



Description:

- PR#2 Scope of Work

Materials	471.49
Quotes	0.00
Labor 2.55hrs	255.00
Tax	34.79
O&P	72.60
Total	833.88

Job Name: Spring Lake Park City Hall Renovations

Job Number: 155

Extension Name: PR#2

Material Filter: <None>

Report: Book Price & NECA 1

Job Details

Name	Value
Job #	155
Lead Estimator	Dan Knutson
Job Name	Spring Lake Park City Hall Renovations
Bid Date	11/20/2023
Contractor Name	
Contractor Telephone	
Customer Name	
Customer Address	
Customer City, State, & Zip	
Customer Telephone	
Customer Fax Number	
Customer E-Mail	
Customer Contact	
Customer Mobile Phone	
Type of Job	Multiple Choice
Job Address	
Job City, State, & Zip	
Job Description	
Contractor Address	
Contractor City, State, & Zip	
Contractor Fax	
Contractor E-Mail	
Contractor Contact (Signs Proposal)	
Proposal Date	
Total Time	20.28
Display in Dashboard	
Job Status	

Job Name: Spring Lake Park City Hall Renovations

Job Number: 155

Material Filter: <None>

Extension Name: PR#2

[ItemsAndByproducts]

Report: Book Price & NECA 1

Item #	Item Name	Quantity	Book Price	U	Book Price	NECA 1	U	ECA 1	E	CCode	% Ext Price	% Ext Hours
Combined->Combined->Combined->Combined->Combined						<u>\$0.00</u>			<u>9.40</u>		<u>0.00%</u>	<u>100.00%</u>
Lighting Control						<u>\$0.00</u>			<u>8.00</u>		<u>0.00%</u>	<u>85.11%</u>
24,376	CONTROL PANEL	1.00	\$0.00	Q	\$0.00	8.00	E	8.00	lc		<u>0.00%</u>	<u>85.11%</u>
MCC/Controls						<u>\$0.00</u>			<u>1.40</u>		<u>0.00%</u>	<u>14.89%</u>
22,214	10A DPDT PLUG-IN RELAY 120V	7.00	\$0.00	Q	\$0.00	0.20	E	1.40	sm		<u>0.00%</u>	<u>14.89%</u>
Transformers						<u>\$0.00</u>			<u>0.00</u>		<u>0.00%</u>	<u>0.00%</u>
17,789	0.25KVA BUCK BOOST XFMR	1.00	\$0.00	Q	\$0.00	0.00	E	0.00	st		<u>0.00%</u>	<u>0.00%</u>
						<u>\$0.00</u>			<u>9.40</u>		<u>100%</u>	<u>100%</u>



CHANGE ORDER REQUEST SUMMARY

CHANGE ORDER REQUEST #: 110

DATE: 5/30/2024

DESCRIPTION : RFI #47 Existing Precast Bearing on New Beam

PROJECT : Spring Lake Park City Hall Renovation / Expansion

C.R.C. PROJECT : 7088

	Supervision and Project Management	RFI #47 Existing Pre Cast Bearing on New Beam	Fabricate, Deliver & Install Steel Haunches on New Beam					TOTALS	RATE	COST
LABOR (MAN-HOURS) :										
LABORER								0.000	\$98.00	\$0.00
LABORER - OVERTIME								0.000	\$147.00	\$0.00
CARPENTER								0.000	\$105.00	\$0.00
CARPENTER - OVERTIME								0.000	\$157.50	\$0.00
SUPERINTENDENT	3.00							3.000	\$150.00	\$450.00
PROJECT MANAGER	2.00							2.000	\$150.00	\$300.00
MATERIALS & EQUIPMENT :										
										\$0.00
										\$0.00
										\$0.00
										\$0.00
										\$0.00
										\$0.00
SUBCONTRACTORS :										
	REFER TO ATTACHED COMMENTS									\$0.00
Linco Fab Inc.			\$ 3,030.00							\$3,030.00
										\$0.00
										\$0.00
										\$0.00
										\$0.00

SUBTOTAL =	\$3,780.00
10% OVERHEAD & FEE =	\$75.00
5% OVERHEAD & FEE =	\$151.50
BOND COST =	\$76.12
TOTAL =	\$4,082.62

Linco Fab. Inc.

12786 60th Street N.E.
St. Michael, MN 55376

Phone: (763) 497-2660
Fax: (763) 497-3986
E-mail: cody@lincosteel.com

DATE: 05/21/24

TO: Construction Results
ATTN: Jason Haraldson
RE: Spring Lake Park City Hall

CITY: Spring Lake Park
PLANS DATED: 10/24/23
PLANS: A001-A802,S001-S502

In accordance with plans and specifications of the referenced project, we propose to furnish and install the materials listed below based on the terms and conditions below.

Total Quotation (Tax Included):	\$	3,030
Structural Steel (Approx):	466 Lbs.	
Steel Joist (Approx):	- Ton	
Metal Deck Primed Gray (Approx):	- Sqs.	
Misc Metals Included (see attachment for details)		

NOTE 1: This is to supply and install the steel for RFI #43

NOTE 2: This is to install the continuous angle and kickers on (1) W16x40 and weld continuous 3/8" x 4" plate on (1) W16x40 that is not erected yet.

Pricing is valid for 15 days unless noted otherwise on this proposal.

Please sign and fax back to 763-497-3986, if Linco is to proceed.

Accepted: _____

DATE: _____

EXCLUSIONS: Bid bond, liquidation damages, testing, performance & payment bonds, field measurements, grout, shims, touch-up painting, cutting holes in deck, barricading of openings, installation of loose lintels (including lintels on bearing plates), embedded items, welding brick angle to metal studs, demolition, painting roof welds, shoring, installation of acoustical insulation, chipping slag off of welds, protection of existing glass, carpet, equipment, and other existing items near the work area, and cleaning of steel after delivery due to muddy job site conditions. Linco must have access to the job site in order to complete work, opening needs to be at least 12 feet wide by 14 feet tall for equipment and trucks when applicable.

Yours very truly
Linco Company

Cody Schoen

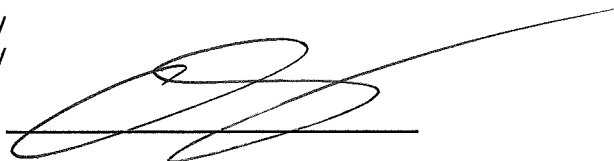



CHANGE ORDER REQUEST SUMMARY

CHANGE ORDER REQUEST #: 112

DATE: 5/31/2024

DESCRIPTION : PR #05 Replace Under Slab Drain Piping

PROJECT : Spring Lake Park City Hall Renovation / Expansion

C.R.C. PROJECT : 7088

	Supervision and Project Management	PR #05 Replace Under Slab Drain Piping	GPR Identification of underground piping	PR #05 Replace Under Slab Drain Piping - Saw Cut & Remove S.O.G.	PR #05 Replace Under Slab Drain Piping - Prep, Install Vapor Barrier, Dowel Rebar	PR #05 Replace Under Slab Drain Piping - Place & Finish Concrete Plumbing Trenches	TOTALS	RATE	COST
LABOR (MAN-HOURS) :									
LABORER				16.00	8.00		24.000	\$98.00	\$2,352.00
LABORER - OVERTIME							0.000	\$147.00	\$0.00
CARPENTER							0.000	\$105.00	\$0.00
CARPENTER - OVERTIME							0.000	\$157.50	\$0.00
SUPERINTENDENT	7.00						7.000	\$150.00	\$1,050.00
PROJECT MANAGER	5.00						5.000	\$150.00	\$750.00
MATERIALS & EQUIPMENT :									
Saw Equipment				\$ 1,091.00					\$1,091.00
Skid loader				\$ 1,955.50					\$1,955.50
Dumpster				\$ 383.00					\$383.00
									\$0.00
									\$0.00
									\$0.00
SUBCONTRACTORS :									
	REFER TO ATTACHED COMMENTS								\$0.00
									\$0.00
Kelleher						\$ 11,034.00			\$11,034.00
Definitive GPR			\$ 200.00						\$200.00
									\$0.00
									\$0.00

SUBTOTAL =	\$18,815.50
10% OVERHEAD & FEE =	\$758.15
5% OVERHEAD & FEE =	\$561.70
BOND COST =	\$382.57
TOTAL =	\$20,517.92

Proposal Request



PROJECT: Spring Lake Park City Hall Renovation/
Expansion Project
1301 81st Avenue NE
Spring Lake Park, MN 55432

PROPOSAL REQUEST NO: 45
DATE: 5/21/2024
PROJECT NO: 193806049
CONTRACT FOR: Building Construction

OWNER: City of Spring Lake Park, MN

TO: Jason Haraldson
Construction Results Corporation
5465 Hwy 169 North
Plymouth, MN 55442

Please submit an itemized quotation for changes in the Contract Sum and/or Time incidental to proposed modifications to the Contract Documents described herein. Your quotation shall be provided to this office at the earliest possible date but no later than 10 days after date listed above to allow for review without impacting the project construction schedule. The quotation and supporting documents can be mailed to my attention at Stantec Consulting Services, Inc., 733 Marquette Avenue, Suite 1000, Minneapolis, MN 55402, or emailed to me at bruce.paulson@stantec.com . Please contact me with any questions at (612) 712-2108.

THIS IS NOT A CHANGE ORDER NOR A DIRECTION TO PROCEED WITH THE WORK DESCRIBED HEREIN.

Written Description of the Work

ITEM NO. 1: Replace underfloor drain piping

SHEET P101 (ISSUED):

1. Replace the existing underfloor drain piping circled in blue on the attached drawing.

Attachments:

1. P101

END OF PROPOSAL REQUEST

ARCHITECT: BRUCE P. PAULSON

Remit To:

HIAWATHA REDDY RENTS, INC.
4411 HIAWATHA AVENUE S
MINNEAPOLIS, MN 55406-3925
www.reddyrents.com



Invoice

Closed	Invoice#
Thu 5/16/2024	178108-1

Customer #: 1993

CONSTRUCTION RESULTS CORP.
5465 Hwy 169 N
Plymouth MN 55442-1903

PO #: 7088

Date Out Mon 5/13/2024

Terms	Aging Date
Net 10th Prox	Thu 5/16/2024

Ordered By: LARSON COREY MICHAEL 763 258-7120

Sales Rep: Kevin Fitzgerald kfitzgerald@reddyrents.com

Delivery Mon 5/13/2024 9:00AM

Pickup Mon 5/20/2024 9:00AM

LARSON COREY MICHAEL 763-258-7120
1301 81ST AVE NE
MINNEAPOLIS, MN 55432

LARSON COREY MICHAEL 763-258-7120
1301 81ST AVE NE
MINNEAPOLIS, MN 55432

Qty	Key	Items Rented	Rental Period	Status	Each	Price
1	16818#01	Skidsteer, JD 317G Track Loader	Mon 5/13/2024 9:00AM to Thu 5/16/2024 2:21PM	Returned	\$1,395.00	\$1,395.00
		Meter Out: 1462.2 Meter In: 1407.6 Total hours on meter: 5.4 4Hrs \$375.00 1day \$375.00 1week \$1,395.00 4weeks \$3,205.00				
1	19850#01	Saw, Core Cut 5049DC - Diesel	Mon 5/13/2024 9:00AM to Thu 5/16/2024 2:21PM	Returned	\$585.00	\$585.00
		1day \$195.00 1week \$585.00 4weeks \$1,755.00				
1	19929-1	Core Cut, 20" Slip-on Blade Guard	Mon 5/13/2024 1:10PM to Thu 5/16/2024 2:21PM	Returned	\$0.00	\$0.00
1	38760-1	Blade, 20" Concrete Rental Blade	Mon 5/13/2024 1:20PM to Thu 5/16/2024 2:21PM	Returned	\$225.00	\$225.00
		4Hrs \$50.00 1day \$60.00 1week \$240.00 4weeks \$500.00				
Qty	Items Sold				Each	Price
29	/DIESEL FUEL - Hiawatha				\$10.00	\$29.00
6	/Diesel, Gallon				\$10.00	\$60.00
1	/Spring Lake Park				\$250.00	\$250.00
1	/Fuel Delivery Surcharge				\$10.99	\$10.99

* Sales Tax Detail MN State \$172.80 Henn Cty Transit \$12.58 MPLS \$12.58 Henn Cty Sales Tax \$3.78 Metro Area Tax for Housing \$6.29 Metro Area Transportation \$18.85

Monday - Friday 7:30am - 5:00pm Saturday: 8:00am - 4:00pm
Printed On Tue 5/28/2024 2:43:19PM

Software by Point of Rental Software www.pointofrental.com

Modification #5
contract-params SQL rpt(9)

Rental:	Damage Waiver:	Sales:	Delivery Charge:		
\$2,205.00	\$264.60	\$99.99	\$260.00		
Subtotal:		Mpls Sales Tax 9.025:	Total:	Paid:	Amount Due:
\$2,819.59		\$228.98	\$3,046.57	\$0.00	\$3,046.57

Current On Account

Signature: _____

CONSTRUCTION RESULTS CORP.

Monday - Friday 7:30am - 5:00pm Saturday: 8:00am - 4:00pm
Printed On Tue 5/28/2024 2:43:19PM

Software by Point of Rental Software www.pointofrental.com

Modification #5
contract-params SQL rpt(9)



Kelleher

May 21, 2024

Kelleher Construction, Inc.
11531 Rupp Drive
Burnsville, MN 55337
(952) 890-6772
Fax: (952) 890-5521

Project: Spring Lake Park City Hall Renovation
Spring Lake Park, MN

Dear Jason:

Below are the hours and concrete charges for pouring the extra infills in the police garage for the five new trench drains:

LABOR:	HRS:	X	RATE:	\$	TOTAL
LABORER	20.00	X	92.14	\$	1,842.80
LABORER FOREMAN	20.00	X	97.07	\$	1,941.40
FINISHER	20.00	X	98.83	\$	1,976.60
FINISHER FOREMAN	20.00	X	106.12	\$	2,122.40
TOTAL LABOR				\$	<u>7,883.20</u>

MATERIAL:	#	UNITS:	X	UNIT	COST:	\$	TOTAL
Concrete w/ Enviro Fee	12.0	CY		165.50	\$	1,986.00	
SUB TOTAL MATERIAL:					\$	1,986.00	
SALES TAX:		%		0.08125	\$	161.36	
TOTAL MATERIAL & TAXES					\$	<u>2,147.36</u>	
TOTAL LABOR & MATERIAL					\$	10,030.56	
SUBTOTAL					\$	10,030.56	
OVERHEAD & PROFIT		%		0.10	\$	1,003.06	
TOTAL COST:					\$	<u>11,034.00</u>	

Please give me a call if you have any questions.

KELLEHER CONSTRUCTION, INC.

Mike Bry

Invoice #12643

THE RADAR GUYS



Billing Address
Construction Results
Corporation
5465 State Highway 169
Service Drive
Plymouth MN 55442 United
States
ap@constructionresults.com

Service Address
Spring Lake Park Admin
Offices - Construction
Results
1301 81st Avenue Northeast
Spring Lake Park MN 55432
United States
ap@constructionresults.com

Send Payment To
Definitive GPR and
Construction Services, LLC.
1340 27th Street
Hudson WI 54016 USA
651-428-1183/507-330-
0617
nicksjobeck@definitivegpr.com

Invoice Date 05/15/24
Sent On 05/15/24
PO # 7088
Total \$500.00
Payments \$0.00
Balance \$500.00

Charges

Item	Description	Unit Cost	Tax	Quantity	Line Total
High Resolution Concrete Imaging	Service Date: 5/10/2024 Located trench drain piping in garage and electrical feeds for furnaces. Searched for possible manhole in drive area, found clean out below asphalt. Asphalt cut and cleanout exposed. Televised sewer through clean out to confirm as sanitary.	\$500.00	⌘	1.0	\$500.00

Subtotal \$500.00
Tax \$0.00
Total ~~-\$500.00~~

Notes

Thank you for your business!

Terms

Due upon receipt

Partial Charge \$200 to PR #05
Remaining balance to be allocated to
separate cost codes



CHANGE ORDER REQUEST SUMMARY

CHANGE ORDER REQUEST #: 113

DATE: 5/31/2024

DESCRIPTION : PR 6 Revise Underground Sanitary Sewer Piping & Connections

PROJECT : Spring Lake Park City Hall Renovation / Expansion

C.R.C. PROJECT : 7088

	Supervision and Project Management	PR 6 Revise Underground Sanitary Sewer Piping	PR 6 Revise Underground Sanitary Sewer Piping - GPR Identification	PR 6 Revise Underground Sanitary Sewer Piping - Asphalt Saw Cutting & Patching	PR 6 Revise Underground Sanitary Sewer Piping - Excavation / Utility Adjustments			TOTALS	RATE	COST
LABOR (MAN-HOURS) :										
LABORER				4.00				4.000	\$98.00	\$392.00
LABORER - OVERTIME								0.000	\$147.00	\$0.00
CARPENTER								0.000	\$105.00	\$0.00
CARPENTER - OVERTIME								0.000	\$157.50	\$0.00
SUPERINTENDENT	3.00							3.000	\$150.00	\$450.00
PROJECT MANAGER	2.00							2.000	\$150.00	\$300.00
MATERIALS & EQUIPMENT :										
Saw Equipment				\$ 250.00						\$250.00
										\$0.00
										\$0.00
										\$0.00
										\$0.00
										\$0.00
SUBCONTRACTORS :										
	REFER TO ATTACHED COMMENTS									
Definitive GPR			\$ 200.00							\$200.00
Kinetic X Xcavating					\$ 639.00					\$639.00
										\$0.00
										\$0.00
										\$0.00

SUBTOTAL =	\$2,231.00
10% OVERHEAD & FEE =	\$139.20
5% OVERHEAD & FEE =	\$41.95
BOND COST =	\$45.83
TOTAL =	\$2,457.98

Proposal Request



PROJECT: Spring Lake Park City Hall Renovation/
Expansion Project
1301 81st Avenue NE
Spring Lake Park, MN 55432

PROPOSAL REQUEST NO: 6
DATE: 5/21/2024
PROJECT NO: 193806049
CONTRACT FOR: Building Construction

OWNER: City of Spring Lake Park, MN

TO: Jason Haraldson
Construction Results Corporation
5465 Hwy 169 North
Plymouth, MN 55442

Please submit an itemized quotation for changes in the Contract Sum and/or Time incidental to proposed modifications to the Contract Documents described herein. Your quotation shall be provided to this office at the earliest possible date but no later than 10 days after date listed above to allow for review without impacting the project construction schedule. The quotation and supporting documents can be mailed to my attention at Stantec Consulting Services, Inc., 733 Marquette Avenue, Suite 1000, Minneapolis, MN 55402, or emailed to me at bruce.paulson@stantec.com. Please contact me with any questions at (612) 712-2108.

THIS IS NOT A CHANGE ORDER NOR A DIRECTION TO PROCEED WITH THE WORK DESCRIBED HEREIN.

Written Description of the Work

ITEM NO. 1: Revise underground sanitary sewer piping and connections

SHEET C002 (ISSUED):

1. Revise the underground sanitary sewer piping as indicated.

Attachments:

1. C002

END OF PROPOSAL REQUEST

ARCHITECT: BRUCE P. PAULSON

THE CONTRACTOR SHALL VERIFY AND BE RESPONSIBLE FOR ALL DIMENSIONS. DO NOT SCALE THE DRAWING. THE CONTRACTOR SHALL VERIFY THE LOCATION OF ALL UTILITIES AND THE PROPERTY OF THE CITY OF SPRING LAKE PARK. THE CONTRACTOR SHALL VERIFY THE LOCATION OF ALL UTILITIES AND THE PROPERTY OF THE CITY OF SPRING LAKE PARK. THE CONTRACTOR SHALL VERIFY THE LOCATION OF ALL UTILITIES AND THE PROPERTY OF THE CITY OF SPRING LAKE PARK.

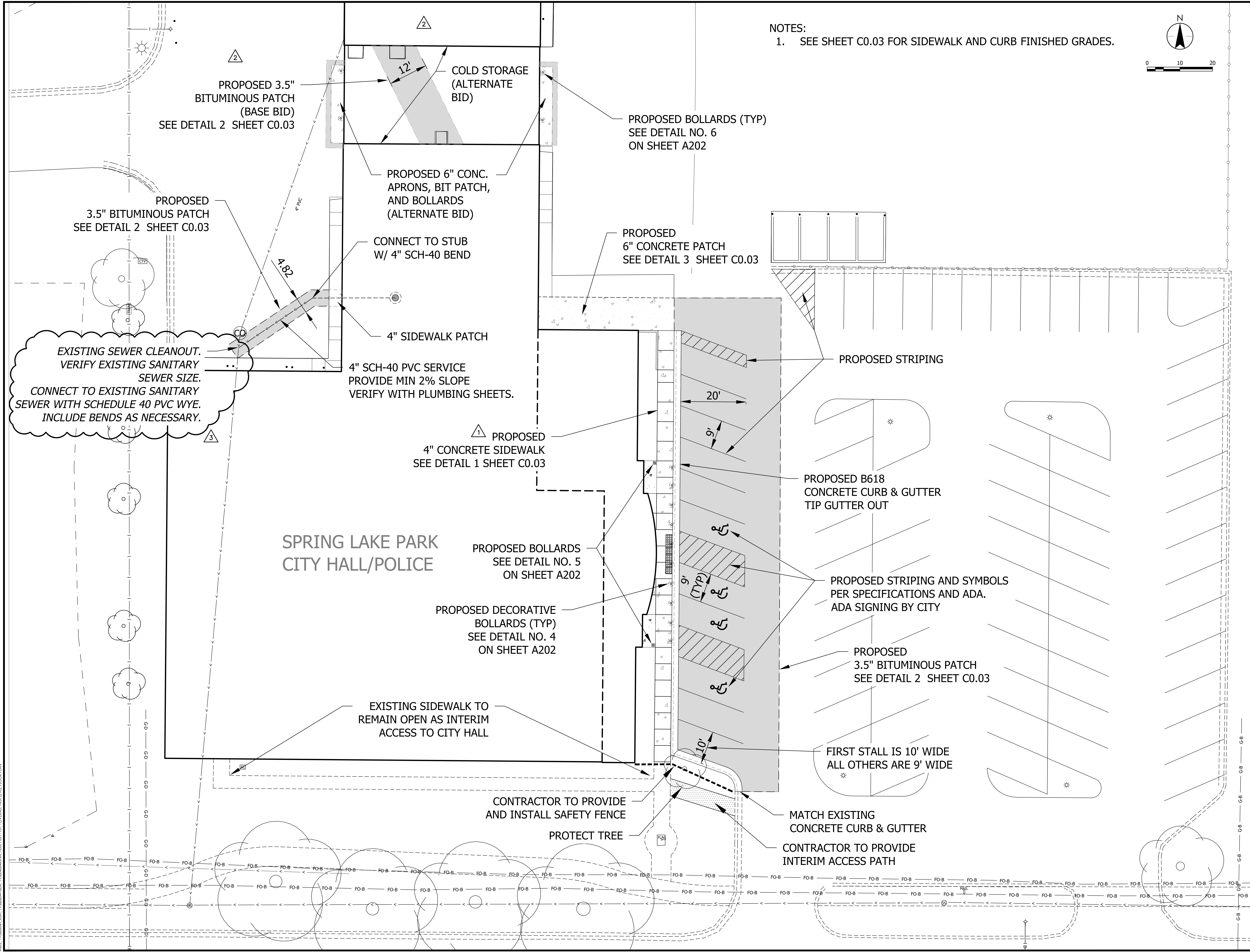

NOTES:
1. SEE SHEET C0.03 FOR SIDEWALK AND CURB FINISHED GRADES.

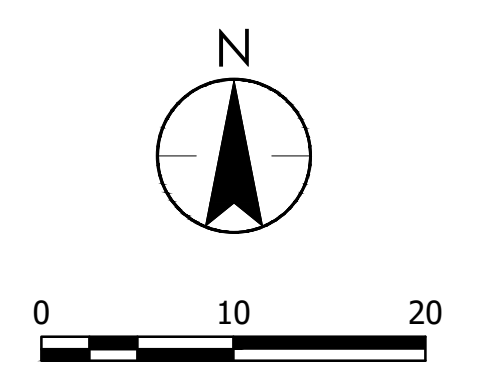

**SPRING LAKE PARK
CITY HALL/POLICE**

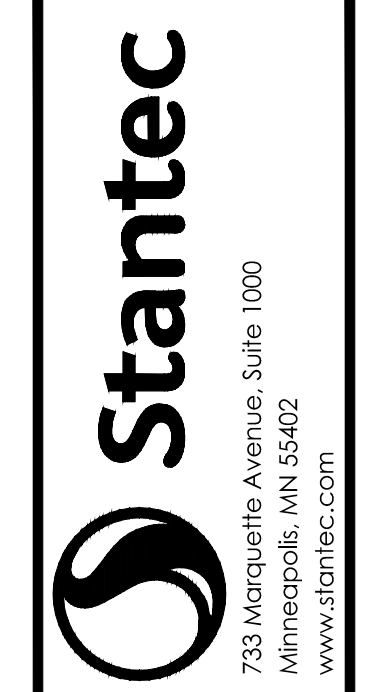

REGISTERED PROFESSIONAL ENGINEER
AND THAT I AM A DULY LICENSED ENGINEER
UNDER THE LAWS OF THE STATE OF MINNESOTA
PRINT NAME: **Paul Howard**
SIGNATURE: *Paul Howard*
DATE: 05/08/2024 09:00 AM TUC: 118564

CITY OF SPRING LAKE PARK, MINNESOTA
CITY HALL RENOVATION/EXPANSION
SITE IMPROVEMENTS PLAN

NO	REVISION	DATE
1	ADDENDUM	11/6/23
2	ADDENDUM	11/15/23
3	PK 6	5/21/24

SURVEY	EAB
DRAWN	GDG
DESIGNED	LFG
CHECKED	BP
APPROVED	LFG

PROJ. NO. 193806049
SHEET NUMBER
C002

THE CONTRACTOR SHALL VERIFY AND BE RESPONSIBLE FOR ALL DIMENSIONS. DO NOT SCALE THE DRAWING. THE CONTRACTOR SHALL VERIFY THE LOCATION OF ALL UTILITIES AND THE DEPTH OF ANY UTILITIES. THE CONTRACTOR SHALL VERIFY THE LOCATION OF ALL UTILITIES AND THE DEPTH OF ANY UTILITIES. THE CONTRACTOR SHALL VERIFY THE LOCATION OF ALL UTILITIES AND THE DEPTH OF ANY UTILITIES.

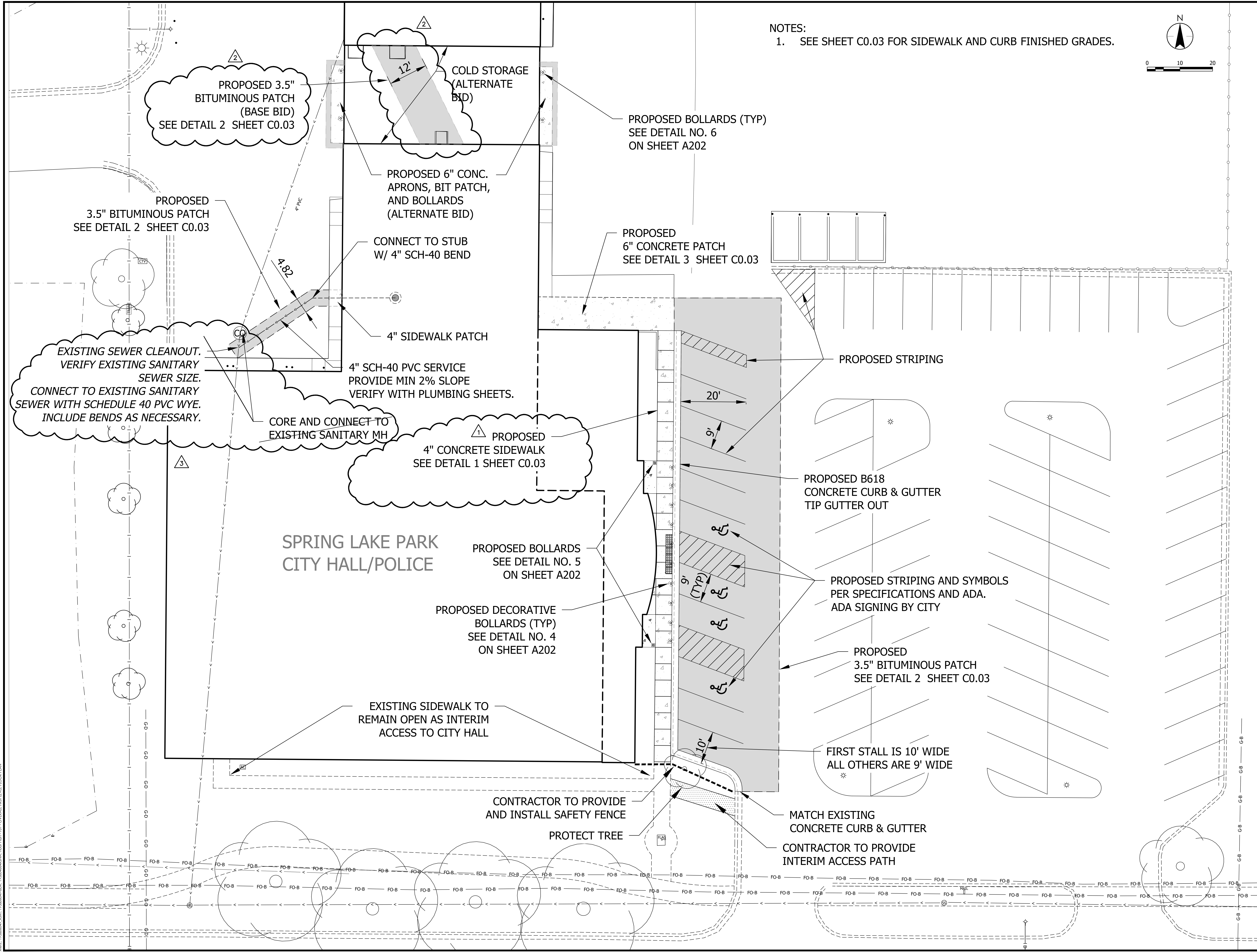

NOTES:
1. SEE SHEET C0.03 FOR SIDEWALK AND CURB FINISHED GRADES.

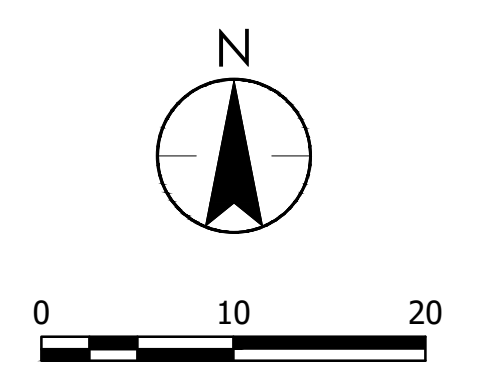

SPRING LAKE PARK CITY HALL/POLICE

Stantec
733 Marquette Avenue, Suite 1000
Minneapolis, MN 55402
www.stantec.com

PRINT NAME: **Phil Howard**
SIGNATURE: *Phil Howard*
DATE: 05/21/24
LIC. NO.: 19386049

CITY OF SPRING LAKE PARK, MINNESOTA
CITY HALL RENOVATION/EXPANSION
SITE IMPROVEMENTS PLAN

NO	REVISION	DATE
1	ADDENDUM	11/6/23
2	ADDENDUM	11/15/23
3	PK 6	5/21/24

SURVEY	EAB
DRAWN	GDH
DESIGNED	LFG
CHECKED	BP
APPROVED	LFG
PROJ. NO.	19386049
SHEET NUMBER	C002

Jason Haraldson

From: Nick Beck <nbeck710@gmail.com>
Sent: Wednesday, May 29, 2024 5:21 PM
To: Heather Clay
Subject: Re: Spring Lake Park City Hall - PR #6

Follow Up Flag: Follow up
Flag Status: Flagged

Hi Heather,

The price impact for PR #6 would be an additional \$639.00.

Please let me know if you have any questions,

Nick

Knetic

651-238-7811

On Tue, May 28, 2024 at 11:32 AM Heather Clay <heather.clay@constructionresults.com> wrote:

Team,

Please see attached PR #6 for the above referenced project. Please reply with cost and schedule impacts no later than **May 31st, 2024** . If this PR does not affect your scope please reply and indicate there is no change.

Please contact Jason if you have any questions.

Thank you.

Heather



**Construction Results
Corporation**

Trusted Commercial & Industrial Contractor

Heather Clay
Project Coordinator

5465 Highway 169 North
Plymouth, MN 55442

O: 763-559-1100

ConstructionResults.com

Confidentiality Notice: The information and any attachment contained in this e-mail message is legally privileged, confidential and intended only for the use of the intended recipient(s). If the receiver of this e-mail message is not the intended recipient, you are hereby notified that any dissemination, distribution or copy of this e-mail is strictly prohibited. If you have received this e-mail message in error, please contact the sender by reply email and destroy all copies of the original message. Thank you.

Invoice #12643

THE RADAR GUYS



Billing Address
Construction Results
Corporation
5465 State Highway 169
Service Drive
Plymouth MN 55442 United
States
ap@constructionresults.com

Service Address
Spring Lake Park Admin
Offices - Construction
Results
1301 81st Avenue Northeast
Spring Lake Park MN 55432
United States
ap@constructionresults.com

Send Payment To
Definitive GPR and
Construction Services, LLC.
1340 27th Street
Hudson WI 54016 USA
651-428-1183/507-330-
0617
nicksjobeck@definitivegpr.com

Invoice Date 05/15/24
Sent On 05/15/24
PO # 7088
Total \$500.00
Payments \$0.00
Balance \$500.00

Charges

Item	Description	Unit Cost	Tax	Quantity	Line Total
High Resolution Concrete Imaging	Service Date: 5/10/2024 Located trench drain piping in garage and electrical feeds for furnaces. Searched for possible manhole in drive area, found clean out below asphalt. Asphalt cut and cleanout exposed. Televised sewer through clean out to confirm as sanitary.	\$500.00	⌘	1.0	\$500.00
				Subtotal	\$500.00
				Tax	\$0.00
				Total	-\$500.00

Notes

Thank you for your business!

Terms

Due upon receipt

Partial Charge \$200 to PR 6
remaining balance allocated to
separate cost codes.



CHANGE ORDER REQUEST SUMMARY

CHANGE ORDER REQUEST #: 114

DATE: 6/24/2024

DESCRIPTION : RFI #49 Existing Roof Penetration Infills

PROJECT : Spring Lake Park City Hall Renovation / Expansion

C.R.C. PROJECT : 7088

	Supervision and Project Management	RFI #49 Existing Roof Penetration Infills	Fabricate, Supply and Deliver Steel Angles	Install Steel Angles at Vestibule Entries				TOTALS	RATE	COST
LABOR (MAN-HOURS) :										
LABORER								0.000	\$98.00	\$0.00
LABORER - OVERTIME								0.000	\$147.00	\$0.00
CARPENTER				8.00				8.000	\$105.00	\$840.00
CARPENTER - OVERTIME								0.000	\$157.50	\$0.00
SUPERINTENDENT	2.00							2.000	\$150.00	\$300.00
PROJECT MANAGER	1.00							1.000	\$150.00	\$150.00
MATERIALS & EQUIPMENT :										
2X8 Framing Material				\$ 24.55						\$24.55
1/2" Plywood Sheathing				\$ 21.98						\$21.98
Fasteners				\$ 24.50						\$24.50
										\$0.00
SUBCONTRACTORS :										
	REFER TO ATTACHED COMMENTS									\$0.00
										\$0.00
										\$0.00
										\$0.00
										\$0.00
										\$0.00

SUBTOTAL =	\$1,361.03
10% OVERHEAD & FEE =	\$136.10
5% OVERHEAD & FEE =	\$0.00
BOND COST =	\$28.45
TOTAL =	\$1,525.58



Construction Results Corporation

Trusted Commercial & Industrial Contractor

5465 HWY 169 NORTH
PLYMOUTH, MN 55442
PHONE : 763-559-1100
FAX : 763-553-0494
www.ConstructionResults.com

REQUEST FOR INFORMATION

Spring Lake Park City Hall Renovation/Expansion

RFI # 49

DATE: 5/29/2024

SUBJECT:

Existing Roof Penetrations

REQUEST: Please see the attached plan sheet A401 with noted pictures regarding the existing roof penetrations.

These penetrations are not noted per the plan documents and no detail noted for patching them.

Please Clarify the design intent for the infill and patching of these penetrations?

RESPONSE:

See markup below:

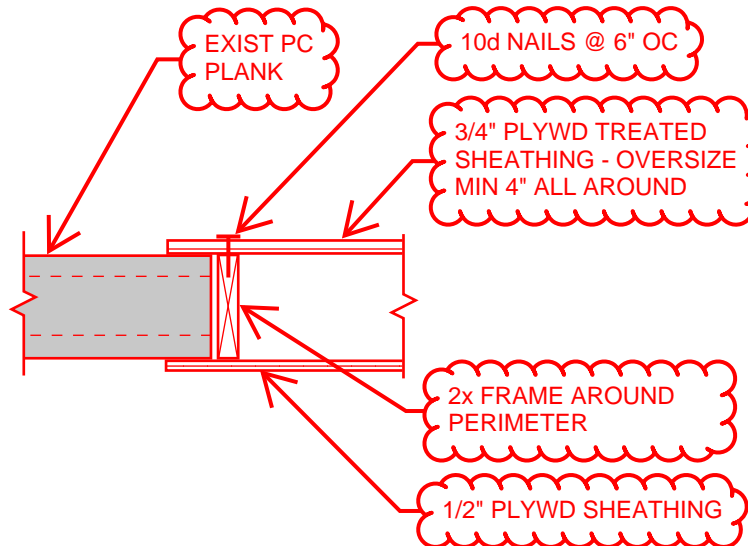

AJM, Stantec
05 June 2024

THE CONTRACTOR SHALL VERIFY AND BE RESPONSIBLE FOR ALL DIMENSIONS. DO NOT SCALE THE DRAWING. DIMENSIONS SHALL BE TO THE CENTERLINE UNLESS OTHERWISE NOTED. REPRODUCTION OF THIS DRAWING FOR ANY PURPOSE OTHER THAN THAT AUTHORIZED BY STANTEC IS FORBIDDEN.

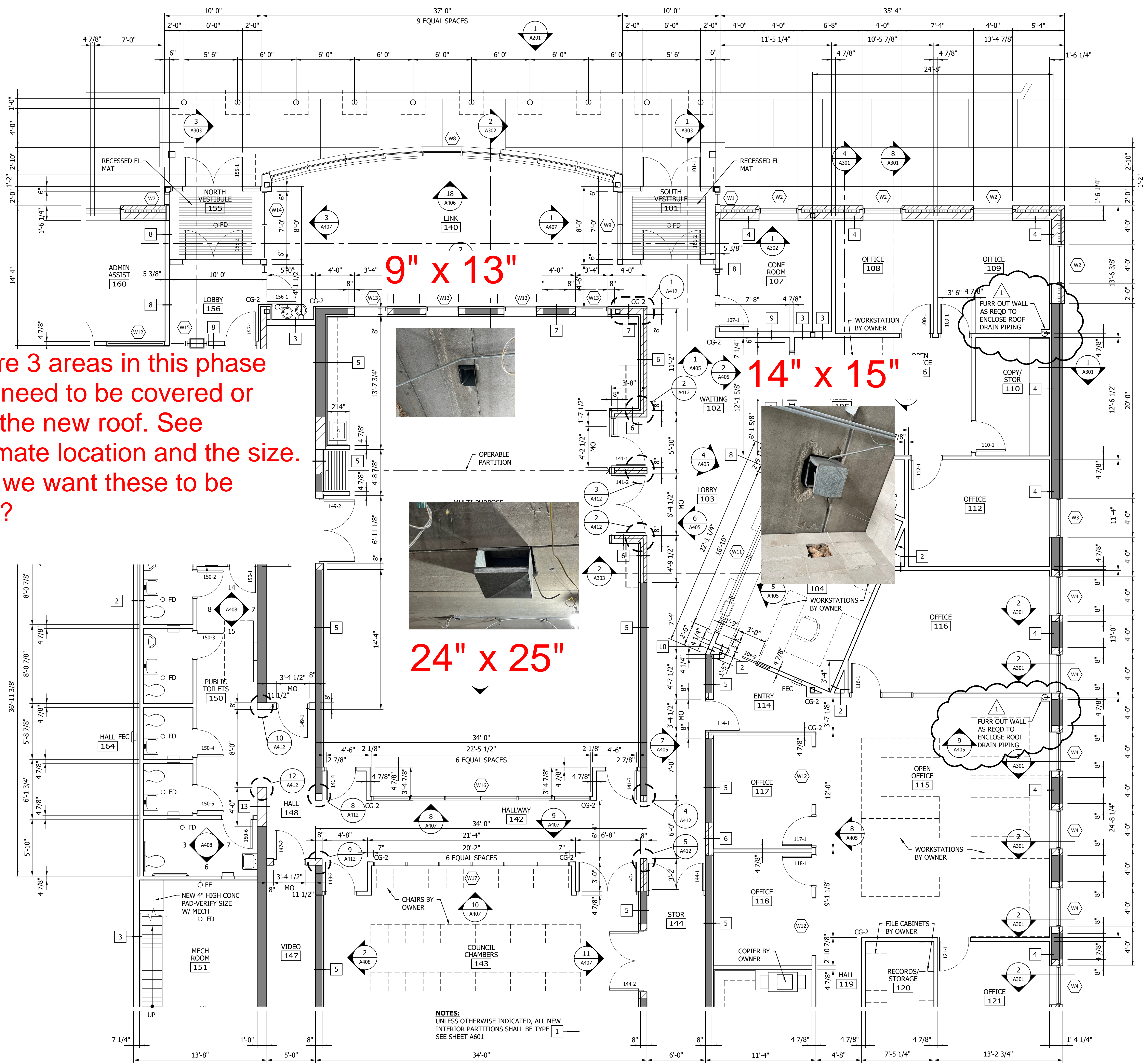

There are 3 areas in this phase that will need to be covered or filed for the new roof. See approximate location and the size. How do we want these to be covered?

9" x 13"

14" x 15"

24" x 25"

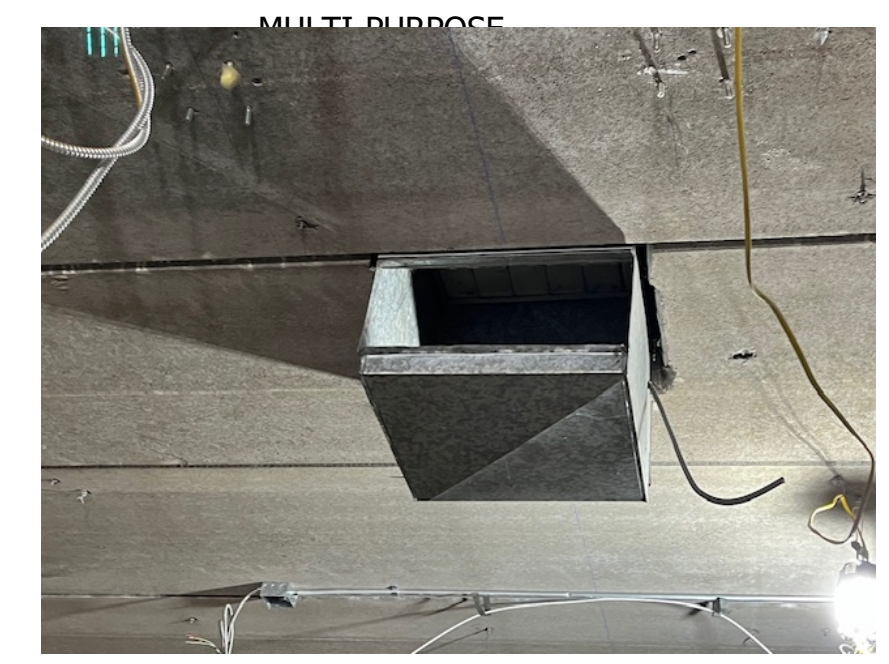

NOTES:
UNLESS OTHERWISE INDICATED, ALL NEW INTERIOR PARTITIONS SHALL BE TYPE 1
SEE SHEET A601

1 PARTIAL ENLARGED FLOOR PLAN

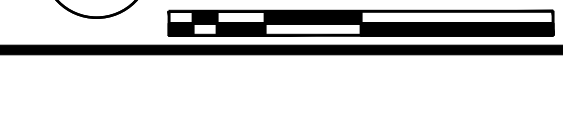

Plot Date: 11/04/2023 11:59 AM
User: J:\Projects\19386049\CAD\Drawings\19386049-A601.dwg
Title: 19386049-A601.dwg

WE HEREBY CERTIFY THAT I AM A REGISTERED PROFESSIONAL ARCHITECT UNDER THE LICENSE OF THE STATE OF MINNESOTA.
PRINT NAME: BRUCE E. PALLS
SIGNATURE: *Bruce E. Palls*
DATE: 11/04/2023 11:59 AM

NO	REVISION	DATE
1	ADD 1	11/06/23

SURVEY	BPP
DRAWN	BPP
DESIGNED	BPP
CHECKED	
APPROVED	
PROJ. NO.	19386049
SHEET NUMBER	A401



CHANGE ORDER REQUEST SUMMARY

CHANGE ORDER REQUEST #: 116

DATE: 6/24/2024

DESCRIPTION : PR 7 Revise Gun Cleaning Room #201 & Secure Storage Room #202

PROJECT : Spring Lake Park City Hall Renovation / Expansion

C.R.C. PROJECT : 7088

	Supervision and Project Management	PR 7 Revise Gun Cleaning Room #201 & Secure Storage Room #202	PR 7 Revise Gun Cleaning Room #201 & Secure Storage Room #203 - Delete Wire Mesh Partition material & installation	PR 7 Revise Gun Cleaning Room #201 & Secure Storage Room #203 - Additional Painting Scope	PR 7 Revise Gun Cleaning Room #201 & Secure Storage Room #203 - Additional Drywall Finish for raised ACT	PR 7 Revise Gun Cleaning Room #201 & Secure Storage Room #203 - Reconfigure & Relocate Existing Cage Door	PR 7 Revise Gun Cleaning Room #201 & Secure Storage Room #203 - Signage Scope Changes	TOTALS	RATE	COST
LABOR (MAN-HOURS) :										
LABORER								0.000	\$98.00	\$0.00
LABORER - OVERTIME								0.000	\$147.00	\$0.00
CARPENTER			-8.00		8.00	12.00	1.00	13.000	\$105.00	\$1,365.00
CARPENTER - OVERTIME								0.000	\$157.50	\$0.00
SUPERINTENDENT	8.00							8.000	\$150.00	\$1,200.00
PROJECT MANAGER	4.00							4.000	\$150.00	\$600.00
MATERIALS & EQUIPMENT :										
Drywall Finish Material					\$ 210.00					\$210.00
Misc. Material - Fasteners						\$ 105.00				\$105.00
										\$0.00
										\$0.00
										\$0.00
										\$0.00
SUBCONTRACTORS :										
	REFER TO ATTACHED COMMENTS									
AP Products			\$ (2,895.00)							\$0.00
Brush Masters Painting & Drywall				\$ 649.00						\$649.00
Niche Visual							\$ 120.00			\$120.00
										\$0.00
										\$0.00
										\$0.00
										\$0.00

SUBTOTAL =	\$1,354.00
10% OVERHEAD & FEE =	\$348.00
5% OVERHEAD & FEE =	-\$106.30
BOND COST =	\$30.32
TOTAL =	\$1,626.02

Proposal Request



PROJECT: Spring Lake Park City Hall Renovation/
Expansion Project
1301 81st Avenue NE
Spring Lake Park, MN 55432

PROPOSAL REQUEST NO: 7R
DATE: 6/5/2024
PROJECT NO: 193806049
CONTRACT FOR: Building Construction

OWNER: City of Spring Lake Park, MN

TO: Jason Haraldson
Construction Results Corporation
5465 Hwy 169 North
Plymouth, MN 55442

Please submit an itemized quotation for changes in the Contract Sum and/or Time incidental to proposed modifications to the Contract Documents described herein. Your quotation shall be provided to this office at the earliest possible date but no later than 10 days after date listed above to allow for review without impacting the project construction schedule. The quotation and supporting documents can be mailed to my attention at Stantec Consulting Services, Inc., 733 Marquette Avenue, Suite 1000, Minneapolis, MN 55402, or emailed to me at bruce.paulson@stantec.com. Please contact me with any questions at (612) 712-2108.

THIS IS NOT A CHANGE ORDER NOR A DIRECTION TO PROCEED WITH THE WORK DESCRIBED HEREIN.

Written Description of the Work

ITEM NO. 1: Revise Gun Cleaning 201 and Secure Storage 202

SHEET A102 (ISSUED):

1. Revise the mezzanine plan to delete the Beastwire Mesh Guarding System at Secure Storage 202 and delete the current Secure Storage 202.
2. Revise the mezzanine plan to rename Storage 203 to be Secure Storage 202.
3. Revise the mezzanine plan to show existing relocated security gate and frame modified to fit in CMU opening.
4. Room Finish Schedule: Revise to match plan changes noted above.

SHEET A304 (ISSUED):

1. Wall Section 2: Revise to show existing relocated security gate and frame at mezzanine level as indicated.
2. Wall Section 2: Revise Storage 203 to read Secure Storage 202 as indicated.

SHEET A410 (ISSUED):

1. Revise elevations 20 and 21 to delete Beastwire Mesh Guarding System as indicated.

ITEM NO. 2: Revise Ceiling Height in Police Storage 170

SHEET A601 (NOT ISSUED):

1. Revise ceiling height in Police Storage 170 from 10'-0" to 12'-0".

ITEM NO. 3: Relocate existing cage door and frame to Hall 166

SHEET A101 (NOT ISSUED):

1. Revise floor plan to show existing cage door and frame relocated to south end of Hall 166.

SHEET A403 (ISSUED):

1. Revise floor plan to show existing cage door and frame relocated to south end of Hall 166. Provide in-wall blocking and shims as necessary to anchor existing frame to both walls. Anchor cage frame to floor to match existing floor anchors.
2. Revise floor plan to delete both CG-2 at the south end of Hall 166 as indicated.

Attachments:

1. A102
2. A304
3. A403
4. A410

END OF PROPOSAL REQUEST

ARCHITECT: BRUCE P. PAULSON

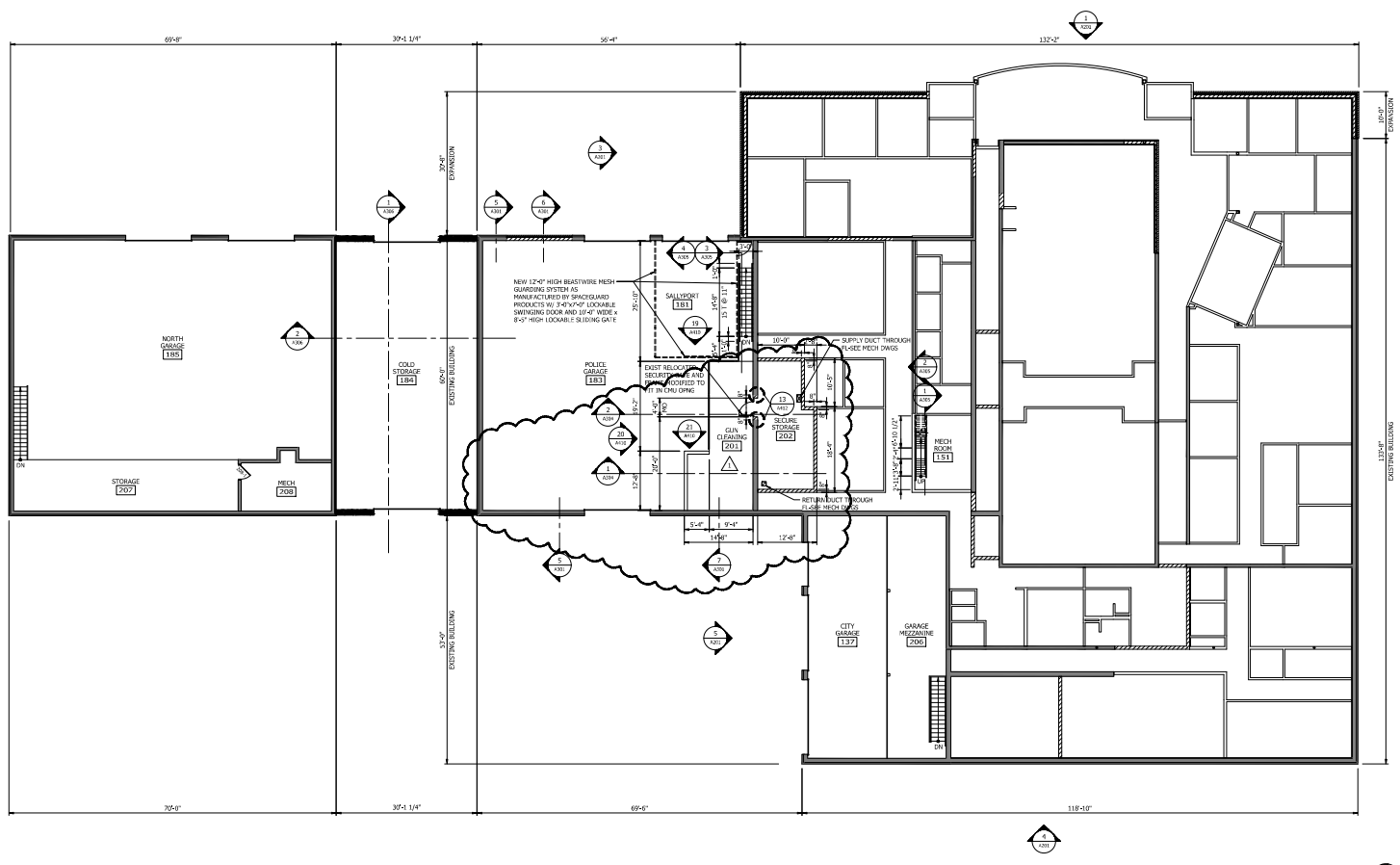

1 RENOVATED MEZZANINE FLOOR PLAN

ROOM FINISH SCHEDULE - MEZZANINE

ROOM NO.	ROOM NAME	FLOOR			WALLS								CEILING		NOTES	
		MATL	FIN	BASE MATL	NORTH MATL	NORTH FIN	SOUTH MATL	SOUTH FIN	EAST MATL	EAST FIN	WEST MATL	WEST FIN	MATL	FIN		HEIGHT
137	CITY GARAGE	EXIST	EXIST	EXIST	EXIST	EXIST	EXIST	EXIST	EXIST	EXIST	EXIST	EXIST	EXIST	EXIST	EXIST	
131	MECH ROOM	CONC/EXIST CONC	SL-1	RB	GYP BD	GP-1	EXIST CMU	16-1	GYP BD	GP-1	GYP BD	GP-1	EXIST MET	EXIST	EXIST	
181	SMALLPORT	EXIST CONC	EXIST	EXIST CMU	-	EXIST CMU	16-1	EXIST CMU	16-1	CMU	16-1	CMU	EXIST MET	EXIST	EXIST	
183	POLICE GARAGE	EXIST/CONC	EXIST/CONC	EXIST CMU	16-1	EXIST/CMU	16-1	EXIST CMU	16-1	EXIST/CMU	16-1	EXIST NET	EXIST	EXIST	EXIST	
184	COLD STORAGE	CONC	SL-1	EXIST/CONC	EXIST CONC	EXIST	EXIST BRICK	EXIST	EXIST	EXIST	CONC	-	NET	-	18'-9"	
185	NORTH GARAGE	EXIST	EXIST	EXIST	EXIST	EXIST	EXIST	EXIST	EXIST	EXIST	EXIST	EXIST	EXIST	EXIST	-	NO WORK THIS ROOM
201	GR CLEANING	CONC	SL-1	EXIST/CMU	CMU	16-1	EXIST/CMU	16-1	CMU	16-1	EXIST CMU	16-1	EXIST MET	EXIST	EXIST	
202	SECURE STORAGE	CONC	SL-1	EXIST/CMU	EXIST CMU	16-1	CMU	16-1	CMU	16-1	CMU	16-1	EXIST MET	EXIST	EXIST	
206	GARAGE MEZZANINE	EXIST	EXIST	EXIST	EXIST	EXIST	EXIST	EXIST	EXIST	EXIST	EXIST	EXIST	EXIST	EXIST	EXIST	
207	STORAGE	EXIST	EXIST	EXIST	EXIST	EXIST	EXIST	EXIST	EXIST	EXIST	EXIST	EXIST	EXIST	EXIST	EXIST	NO WORK THIS ROOM
208	MECH	EXIST	EXIST	EXIST	EXIST	EXIST	EXIST	EXIST	EXIST	EXIST	EXIST	EXIST	EXIST	EXIST	EXIST	NO WORK THIS ROOM

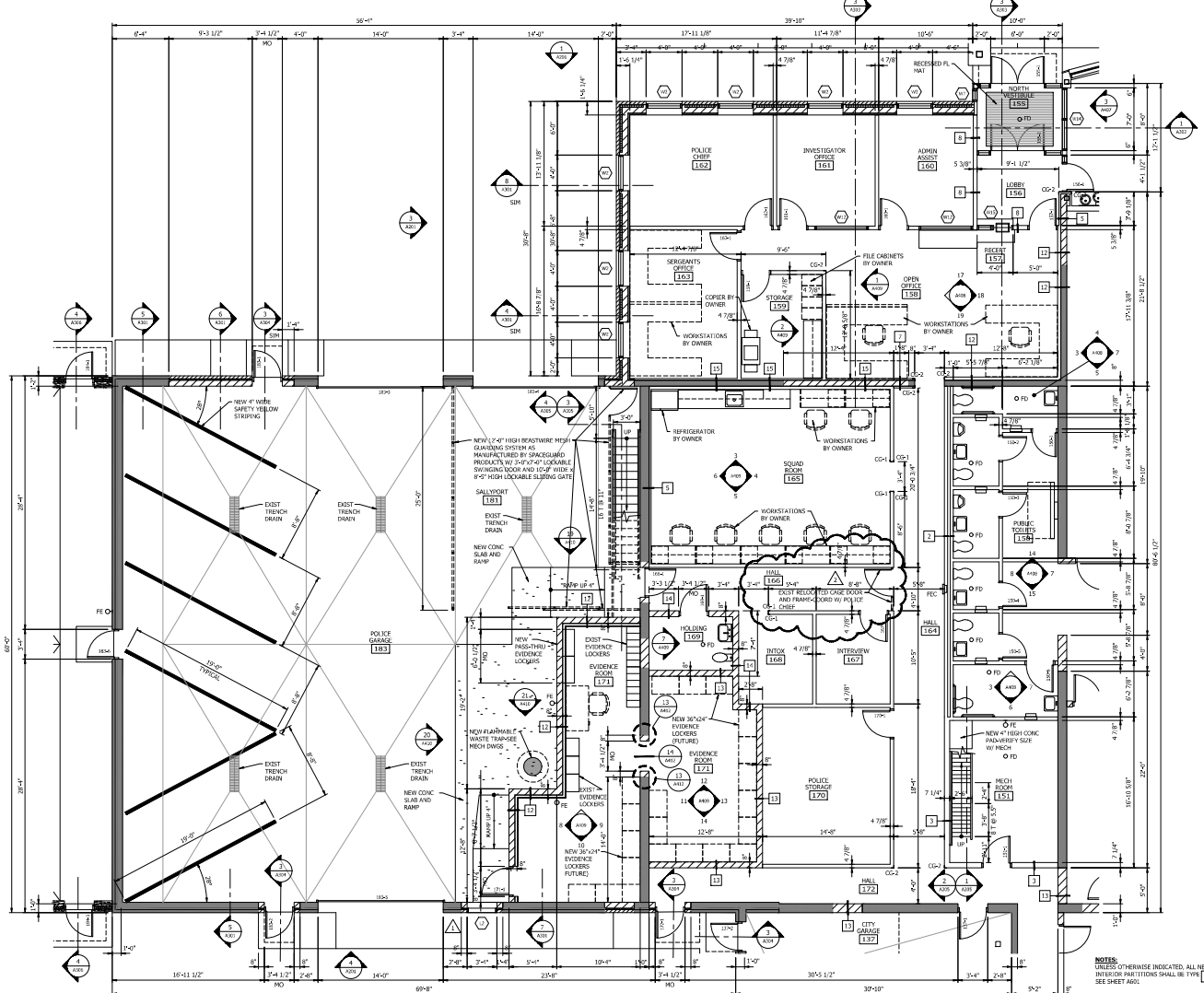

1 PARTIAL ENLARGED FLOOR PLAN

NOTES:
UNLESS OTHERWISE INDICATED, ALL NEW
WINDOW PARTITIONS SHALL BE TYPE 1
SEE SHEET A041.

Stantec

1000 Prairie Avenue, Suite 1000
Minneapolis, MN 55415
Tel: 612.222.2222
Fax: 612.222.2222
www.stantec.com

CITY OF SPRING LAKE PARK, MINNESOTA
CITY HALL RENOVATION/EXPANSION
PARTIAL ENLARGED FLOOR PLAN

DATE	01/11/17
BY	JK
CHECKED	JK
DATE	01/11/17
BY	JK
CHECKED	JK
DATE	01/11/17
BY	JK
CHECKED	JK
DATE	01/11/17
BY	JK
CHECKED	JK

A403

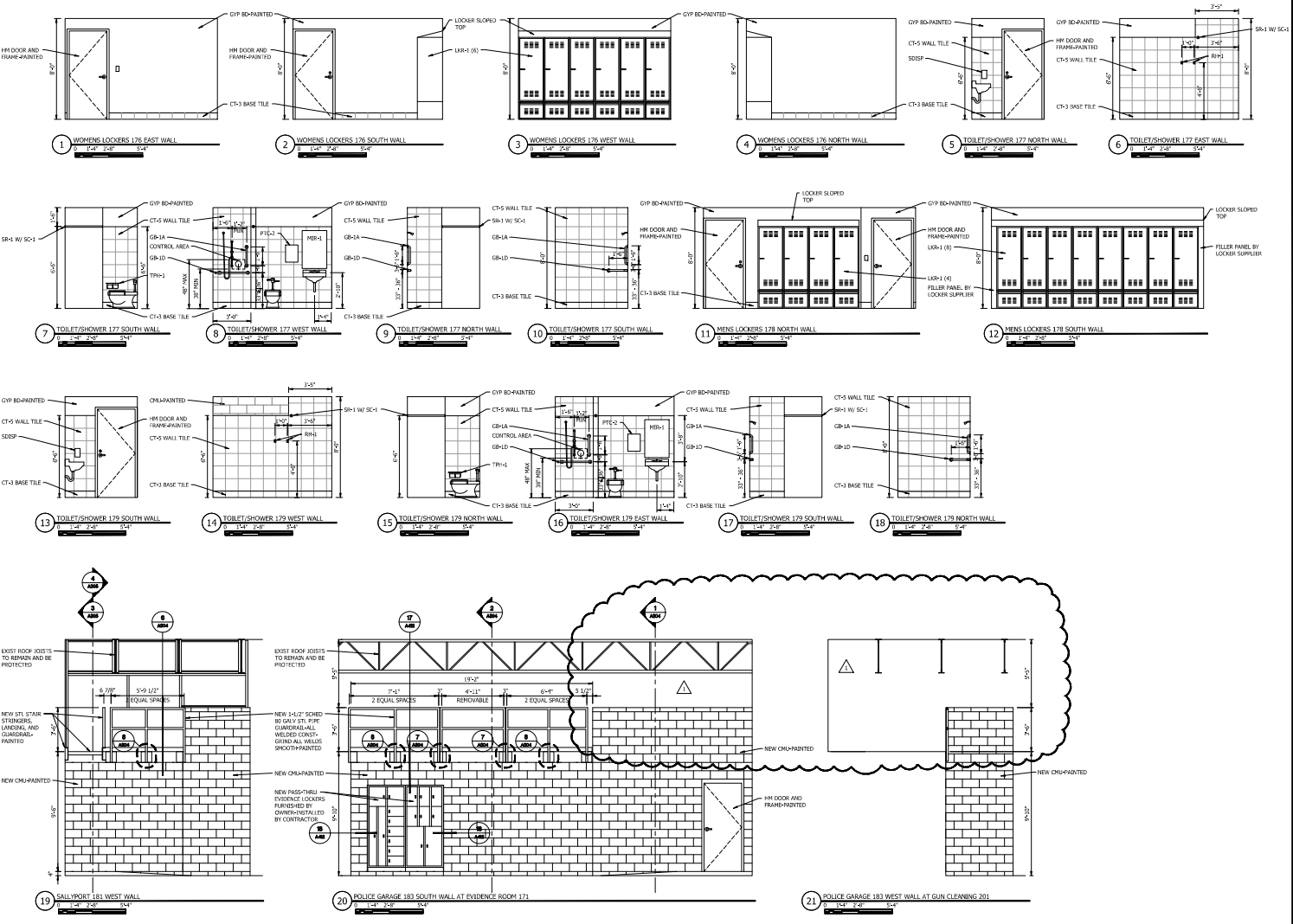



Architectural Products

23700 324TH AVE • UNDERWOOD, MN 56586 • TELEPHONE 218-589-7801

APPRODUCTS@PRTEL.COM WWW.APPRODUCTS10200.COM

Construction Results Corporation
5465 Highway 169 north
Plymouth, MN. 55442

Jason Haraldson

Re: Spring Lake Park City Hall
Wire Mesh
PR#7

Deduct for the upper wire mesh is \$2,895.00

Thank You
Ron Wilcox



Paint - Proposal

11775 95th Ave N | Maple Grove, MN 55369

Phone (763) 478-3232 | Fax (763) 496-0910

Customer Name:

Construction Results
 14170 23rd Ave N
 Plymouth, MN 55447

Job Information:

SLP Reno
 1301 81st Avenue Northeast
 Spring Lake Park, MN 55432

Estimate Notes:

- Addendum 1-3 acknowledge
- 5 phases included
- No work at shooting range 186, North Garage 185, Cold Storage 184, Police Garage 183, Sallyport 181, City Garage 137
- No work on existing areas not called out to paint
- No work on ships ladder
- No work on roof hatch
- No painting of exterior walls
- No work on roof
- No work on floors
- No work on corner guards
- No work on chair railing
- No work on radiation
- No work on cabinets
- No work on lockers
- No work on toilet partitions
- No work on ceiling grid
- No work on exposed ceilings
- No work on misc. items at exterior of building
- No work at mezzanine
- No work on mesh guarding system
- No work on wood items
- No work on wood doors - Assume to be prefinished per 02-Specifications
- No work with tmemec coatings, acid washing, epoxy
- No major wall patching/skimming
- No after-hours labor

Level	Location	Description of Work	Notes	Net Price
		COM-Paint Gypsum Walls		\$65,776.70
		COM-Paint CMU Walls	Paint CMU wall at Sallport 181 west, Police Garage 183 South wall at evidence room 171, Police garage 183 at gun cleaning 201 sheet A410 elevation 19-21	
		Description	Phasing QTY 5	
		COM-Paint HM Frames - New		
		COM-Paint HM Frames - Existing		
		COM-Paint HM Standard sidelights		
		COM-Paint HM Doors		
		COM-Accent Cuts		
		COM-Paint Cut Line		
		COM-Paint Steel Railings	Paint steel railings at interior stairs	
		COM-Bollards		



Paint - Proposal

11775 95th Ave N | Maple Grove, MN 55369

Phone (763) 478-3232 | Fax (763) 496-0910

COM-Labor Hourly

Paint Spring Lake Park

COM-Touchup Labor

Change Order

Change Order

PR #7 Painting per plan changes. \$649.00

Total base bid prices [Excludes T&M items]	\$65,776.70
Total Time and Materials Items	\$0.00
Change order Items	\$649.00
Total of all options	\$0.00
Total of Base + T&M + Options + Change Orders (Tax Included)	\$66,425.70

**Options are denoted by asterisks and italicized.*

This proposal is good for 60 days.

Respectfully submitted by,

Robert Antilla
Commercial Sales and Estimating Leader
robert@brushmasters.com

Signature

Date

Print Name



CHANGE ORDER REQUEST SUMMARY

CHANGE ORDER REQUEST #: 117

DATE: 6/25/2024

DESCRIPTION : Owner Requested Plastic Laminate Material Change

PROJECT : Spring Lake Park City Hall Renovation / Expansion

C.R.C. PROJECT : 7088

	Supervision and Project Management	Owner Requested Plastic Laminate Material Change						TOTALS	RATE	COST
LABOR (MAN-HOURS) :										
LABORER								0.000	\$98.00	\$0.00
LABORER - OVERTIME								0.000	\$147.00	\$0.00
CARPENTER								0.000	\$105.00	\$0.00
CARPENTER - OVERTIME								0.000	\$157.50	\$0.00
SUPERINTENDENT		1.00						1.000	\$150.00	\$150.00
PROJECT MANAGER		1.00						1.000	\$150.00	\$150.00
MATERIALS & EQUIPMENT :										
										\$0.00
										\$0.00
										\$0.00
										\$0.00
										\$0.00
										\$0.00
SUBCONTRACTORS :										
	REFER TO ATTACHED COMMENTS									\$0.00
Southern Minnesota Woodcraft		\$ 2,172.42								\$2,172.42
										\$0.00
										\$0.00
										\$0.00
										\$0.00

SUBTOTAL =	\$2,472.42
10% OVERHEAD & FEE =	\$30.00
5% OVERHEAD & FEE =	\$108.62
BOND COST =	\$49.61
TOTAL =	\$2,660.65

Jason Haraldson

From: Jason Haraldson
Sent: Wednesday, June 19, 2024 1:38 PM
To: Paulson, Bruce
Cc: Gary Swift; Heather Clay
Subject: RE: Spring Lake Park City Hall plastic laminate color changes

Thank you Bruce, we will get submittals and samples coming immediately.

Jason



Jason Haraldson
Project Manager / Estimator
5465 Highway 169 North
Plymouth, MN 55442
C: 612-919-0234
O: 763-559-1100x117
ConstructionResults.com

Confidentiality Notice: The information and any attachment contained in this e-mail message is legally privileged, confidential and intended only for the use of the intended recipient(s). If the receiver of this e-mail message is not the intended recipient, you are hereby notified that any dissemination, distribution or copy of this e-mail is strictly prohibited. If you have received this e-mail message in error, please contact the sender by reply email and destroy all copies of the original message. Thank you.

From: Paulson, Bruce <Bruce.Paulson@stantec.com>
Sent: Wednesday, June 19, 2024 1:08 PM
To: Jason Haraldson <Jason.Haraldson@constructionresults.com>
Cc: Gary Swift <gary.swift@constructionresults.com>; Heather Clay <heather.clay@constructionresults.com>
Subject: RE: Spring Lake Park City Hall plastic laminate color changes

Hi Jason,
Just received approval from Dan Buchholtz to proceed with the plastic laminate colors change.
Thank you.

Bruce P. Paulson
Senior Project Manager/Architect
Direct: 612 712-2108
Mobile: 651 492-9089
Bruce.Paulson@stantec.com
Stantec
733 Marquette Avenue Suite 1000
Minneapolis MN 55402-2309



The content of this email is the confidential property of Stantec and should not be copied, modified, retransmitted, or used for any purpose except with Stantec's written authorization. If you are not the intended recipient, please delete all copies and notify us immediately.

From: Jason Haraldson <Jason.Haraldson@constructionresults.com>
Sent: June 19, 2024 8:42 AM
To: Paulson, Bruce <Bruce.Paulson@stantec.com>
Cc: Gary Swift <gary.swift@constructionresults.com>; Heather Clay <heather.clay@constructionresults.com>
Subject: RE: Spring Lake Park City Hall plastic laminate color changes

Good morning Bruce,

Thank you for the quick response, I have relayed this to Southern Woodcraft as we need to proceed as quickly as possible to maintain our schedule and their production. Please see below the response I have received, due to the P-lam having been approved they have ordered and received it to maintain their production schedule. Given it is not a stock item special order their will be a cost to switch to the new chosen P-lam colors. Please advise if we should proceed and submit a COR for this cost and we can proceed immediately with submittals and samples of the new selected laminate.

Thank you,
Jason

Jason,

The previous countertop laminate was a non-stock special order laminate and was approved so because of lead time and previously being approved we have already received the previous specified approved laminate and e is non-returnable, the cost to replace when the new selected color would require an approval of a change order of \$2,172.42.

Please advise how we should proceed.

Thanks,

*Ken Weikert
Estimating/Sales/Project Management
Southern MN Woodcraft*



Jason Haraldson
Project Manager / Estimator
5465 Highway 169 North
Plymouth, MN 55442
C: 612-919-0234
O: 763-559-1100x117
ConstructionResults.com

Confidentiality Notice: The information and any attachment contained in this e-mail message is legally privileged, confidential and intended only for the use of the intended recipient(s). If the receiver of this e-mail message is not the intended recipient, you are hereby notified that any dissemination, distribution or copy of this e-mail is strictly prohibited. If you have received this e-mail message in error, please contact the sender by reply email and destroy all copies of the original message. Thank you.

From: Paulson, Bruce <Bruce.Paulson@stantec.com>
Sent: Tuesday, June 18, 2024 11:03 AM
To: Jason Haraldson <Jason.Haraldson@constructionresults.com>
Cc: Gary Swift <gary.swift@constructionresults.com>; Dan Buchholtz <dbuchholtz@slpmn.org>; Wanda Brown <wbrown@slpmn.org>; Jeff Baker <jbaker@slpmn.org>; Kay Okey <kokey@slpmn.org>; George Linngren <glinngren@slpmn.org>; Josh Antoine <jantoine@slpmn.org>
Subject: Spring Lake Park City Hall plastic laminate color changes

Hi Jason,
Here are the plastic laminate color changes:
Countertop: Wilsonart Madura Pearl 4922K-52 Quarry Finish
Base and Wall Cabinets: Wilsonart Grey 1500-60 Matte Finish

Let me know if you have any questions.

Thank you.

Bruce P. Paulson

Senior Project Manager/Architect

Direct: 612 712-2108

Mobile: 651 492-9089

Bruce.Paulson@stantec.com

Stantec

733 Marquette Avenue Suite 1000

Minneapolis MN 55402-2309



The content of this email is the confidential property of Stantec and should not be copied, modified, retransmitted, or used for any purpose except with Stantec's written authorization. If you are not the intended recipient, please delete all copies and notify us immediately.

Caution: This email originated from outside of Stantec. Please take extra precaution.

Attention: Ce courriel provient de l'extérieur de Stantec. Veuillez prendre des précautions supplémentaires.

Atención: Este correo electrónico proviene de fuera de Stantec. Por favor, tome precauciones adicionales.



CHANGE ORDER REQUEST SUMMARY

CHANGE ORDER REQUEST #: 119

DATE: 7/31/2024

DESCRIPTION : PR #9 Remove & Replace Additional Pavement

PROJECT : Spring Lake Park City Hall Renovation / Expansion

C.R.C. PROJECT : 7088

	Supervision and Project Management	PR 9 Remove & Replace Additional Pavement	Saw Cut & Remove additional Pavement - Export and Import Aggregate Base	Prep & Place New Bituminous Base Coat & Wear Coat				TOTALS	RATE	COST
LABOR (MAN-HOURS) :										
LABORER								0.000	\$98.00	\$0.00
LABORER - OVERTIME								0.000	\$147.00	\$0.00
CARPENTER								0.000	\$105.00	\$0.00
CARPENTER - OVERTIME								0.000	\$157.50	\$0.00
SUPERINTENDENT	6.00							6.000	\$150.00	\$900.00
PROJECT MANAGER	4.00							4.000	\$150.00	\$600.00
MATERIALS & EQUIPMENT :										
										\$0.00
										\$0.00
										\$0.00
										\$0.00
										\$0.00
										\$0.00
										\$0.00
SUBCONTRACTORS :										
	REFER TO ATTACHED COMMENTS									\$0.00
Kinetic X Xcavating			\$ 3,173.00							\$3,173.00
A.R.C. Paving				\$ 1,368.75						\$1,368.75
										\$0.00
										\$0.00
										\$0.00
										\$0.00

SUBTOTAL =	\$6,041.75
10% OVERHEAD & FEE =	\$150.00
5% OVERHEAD & FEE =	\$227.09
BOND COST =	\$121.96
TOTAL =	\$6,540.80



Proposal Request

PROJECT: Spring Lake Park City Hall Renovation/
Expansion Project
1301 81st Avenue NE
Spring Lake Park, MN 55432

PROPOSAL REQUEST NO: 9
DATE: 7/11/2024
PROJECT NO: 193806049
CONTRACT FOR: Building Construction

OWNER: City of Spring Lake Park, MN

TO: Jason Haraldson
Construction Results Corporation
5465 Hwy 169 North
Plymouth, MN 55442

Please submit an itemized quotation for changes in the Contract Sum and/or Time incidental to proposed modifications to the Contract Documents described herein. Your quotation shall be provided to this office at the earliest possible date but no later than 10 days after date listed above to allow for review without impacting the project construction schedule. The quotation and supporting documents can be mailed to my attention at Stantec Consulting Services, Inc., 733 Marquette Avenue, Suite 1000, Minneapolis, MN 55402, or emailed to me at bruce.paulson@stantec.com. Please contact me with any questions at (612) 712-2108.

THIS IS NOT A CHANGE ORDER NOR A DIRECTION TO PROCEED WITH THE WORK DESCRIBED HEREIN.

Written Description of the Work

ITEM NO. 1: Remove and replace additional bituminous pavement per Owner request

Sheet C002 (ISSUED):

1. Revise site plan to show additional removal and replacement of bituminous pavement as requested by the Owner.

Sheet C003 (ISSUED):

1. Revise site plan to show additional removal and replacement of bituminous pavement as requested by the Owner.

Attachments:

1. Sheet C002
2. Sheet C003

END OF PROPOSAL REQUEST

ARCHITECT: BRUCE P. PAULSON

THE CONTRACTOR SHALL VERIFY AND BE RESPONSIBLE FOR ALL DIMENSIONS. DO NOT SCALE THE DRAWING. THE CONTRACTOR SHALL VERIFY THE LOCATION OF ALL UTILITIES AND THE DEPTH OF ALL UTILITIES. THE CONTRACTOR SHALL VERIFY THE LOCATION OF ALL UTILITIES AND THE DEPTH OF ALL UTILITIES. THE CONTRACTOR SHALL VERIFY THE LOCATION OF ALL UTILITIES AND THE DEPTH OF ALL UTILITIES.

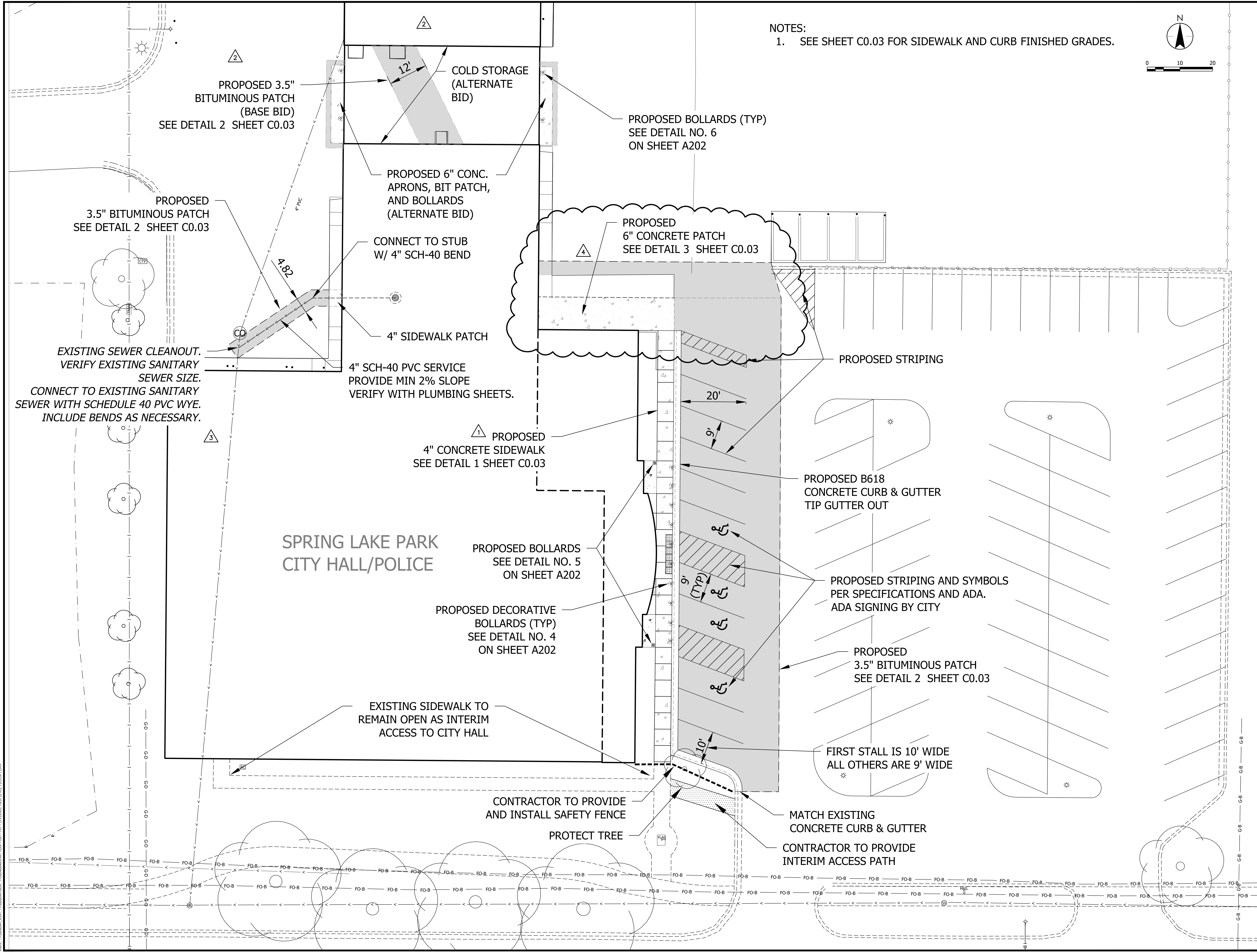

NOTES:
 1. SEE SHEET C0.03 FOR SIDEWALK AND CURB FINISHED GRADES.

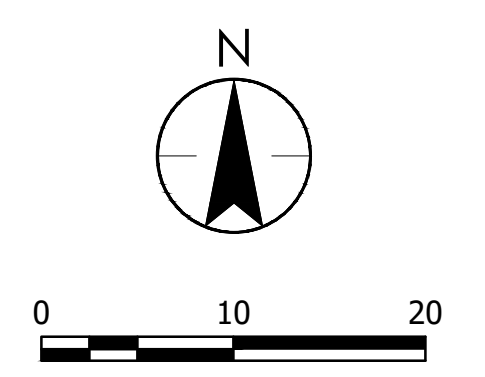

SPRING LAKE PARK
 CITY HALL/POLICE

Stantec
 733 Marquette Avenue, Suite 1000
 Minneapolis, MN 55402
 www.stantec.com

PRINT NAME: *Paul Howard*
 SIGNATURE: *Paul Howard*
 DATE: 05/08/2024 10:00 AM

CITY OF SPRING LAKE PARK, MINNESOTA
 CITY HALL RENOVATION/EXPANSION
 SITE IMPROVEMENTS PLAN

NO	REVISION	DATE
1	ADDENDUM	11/6/23
2	ADDENDUM	11/15/23
3	PR 6	5/21/24
4	PR 7	7/11/24

SURVEY	EAB
DRAWN	GDH
DESIGNED	LFG
CHECKED	BP
APPROVED	LFG
PROJ. NO.	193806049
SHEET NUMBER	C002

THE CONTRACTOR SHALL VERIFY AND BE RESPONSIBLE FOR ALL DIMENSIONS. DO NOT SCALE THE DRAWING. THE CONTRACTOR SHALL VERIFY ALL DIMENSIONS AND DRAWINGS ARE THE PROPERTY OF STANTEC. REPRODUCTION OR USE FOR ANY PURPOSE OTHER THAN THAT AUTHORIZED BY STANTEC IS FORBIDDEN.

NOTES:

1. CONTRACTOR TO INSTALL AN EXPANSION JOINT AND CAULK BETWEEN BUILDING AND CONCRETE SIDEWALK SURFACES.
2. SEE STOOP DETAIL 6 ON SHEET S501.
3. SIDEWALK GRADES BASED ON FF ELEV OF 908.50 (VERIFY).
4. ADA PARKING SIGNING BY CITY.
5. SEE BOLLARD DETAILS ON SHEETS A202, E202, AND E204.

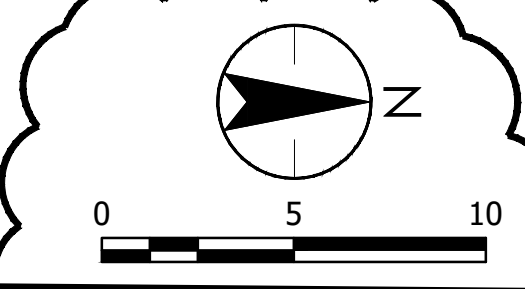
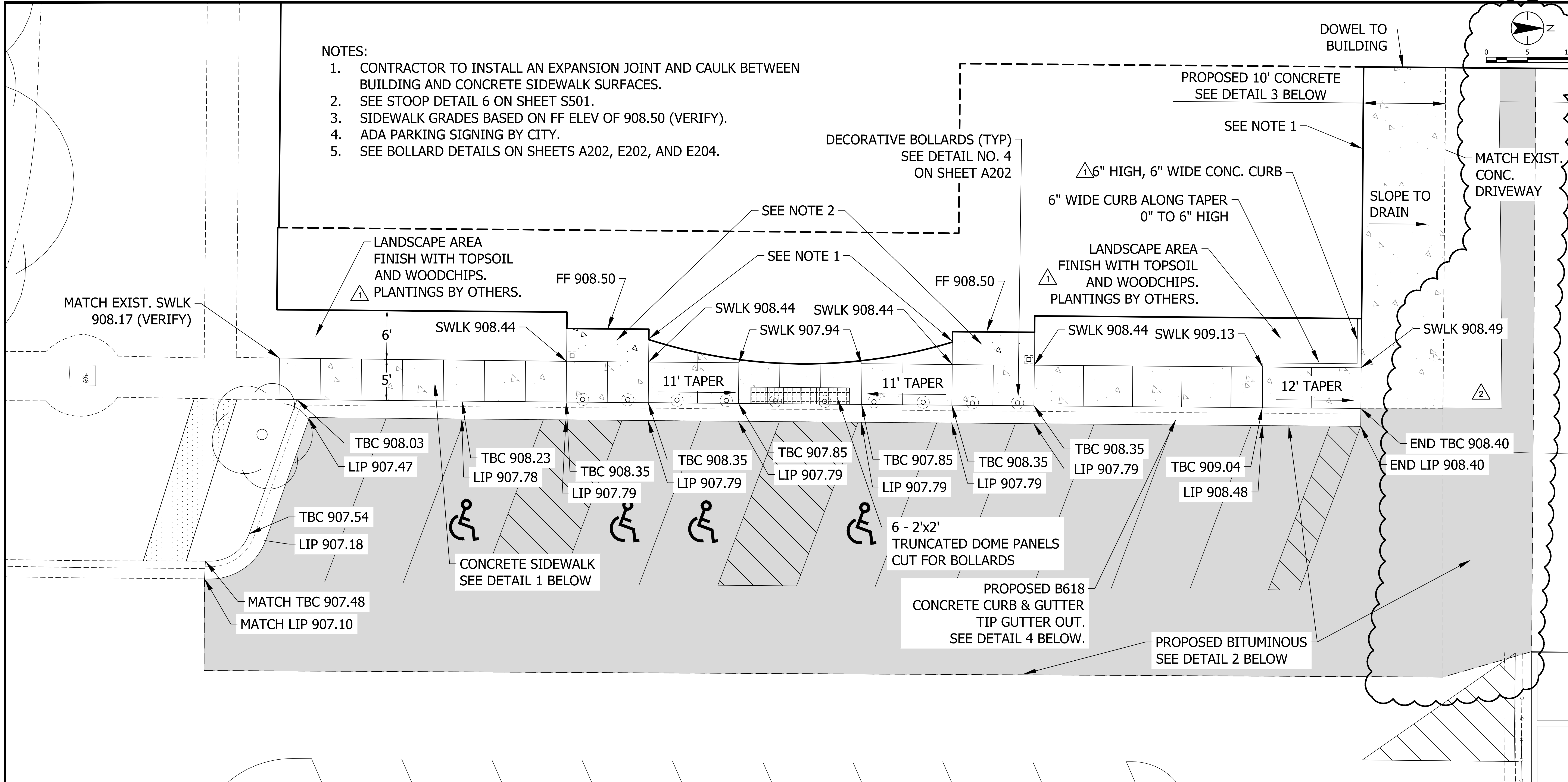

DESIGNED BY: [Signature]
CHECKED BY: [Signature]
DATE: 11/26/23
PROJECT NO.: 193806047

CITY OF SPRING LAKE PARK, MINNESOTA
CITY HALL RENOVATION/EXPANSION
SITE IMPROVEMENTS PLAN

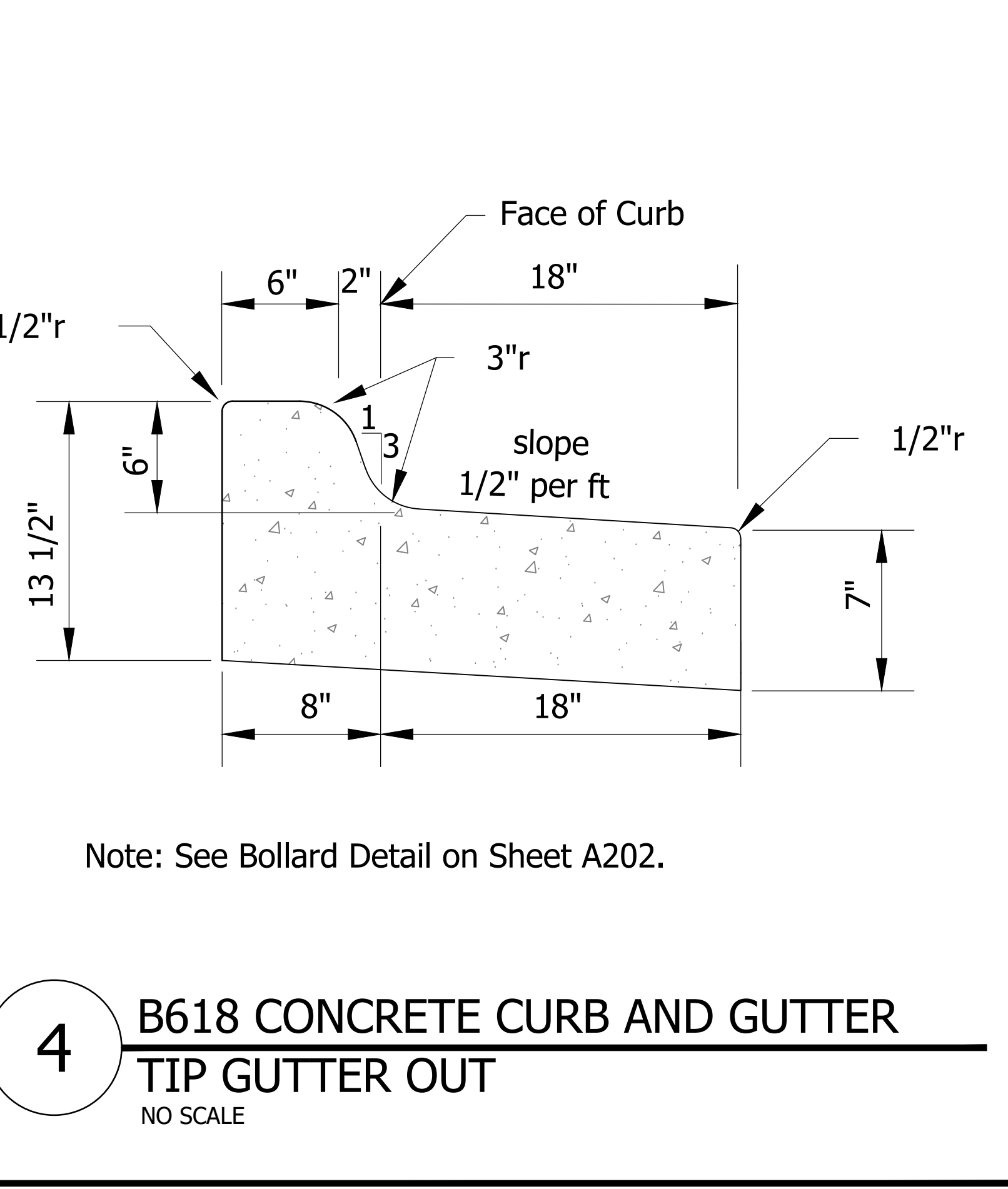
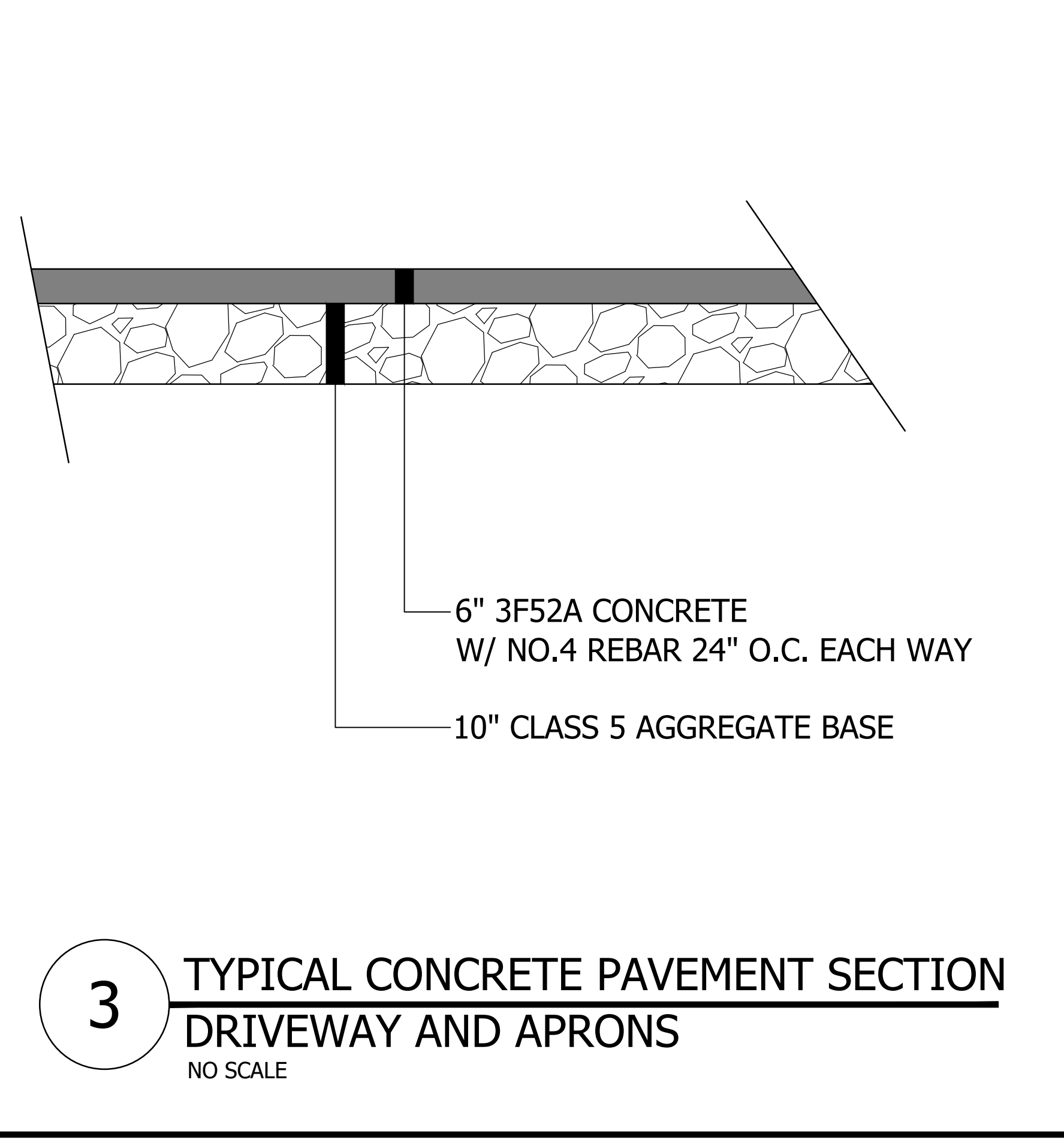
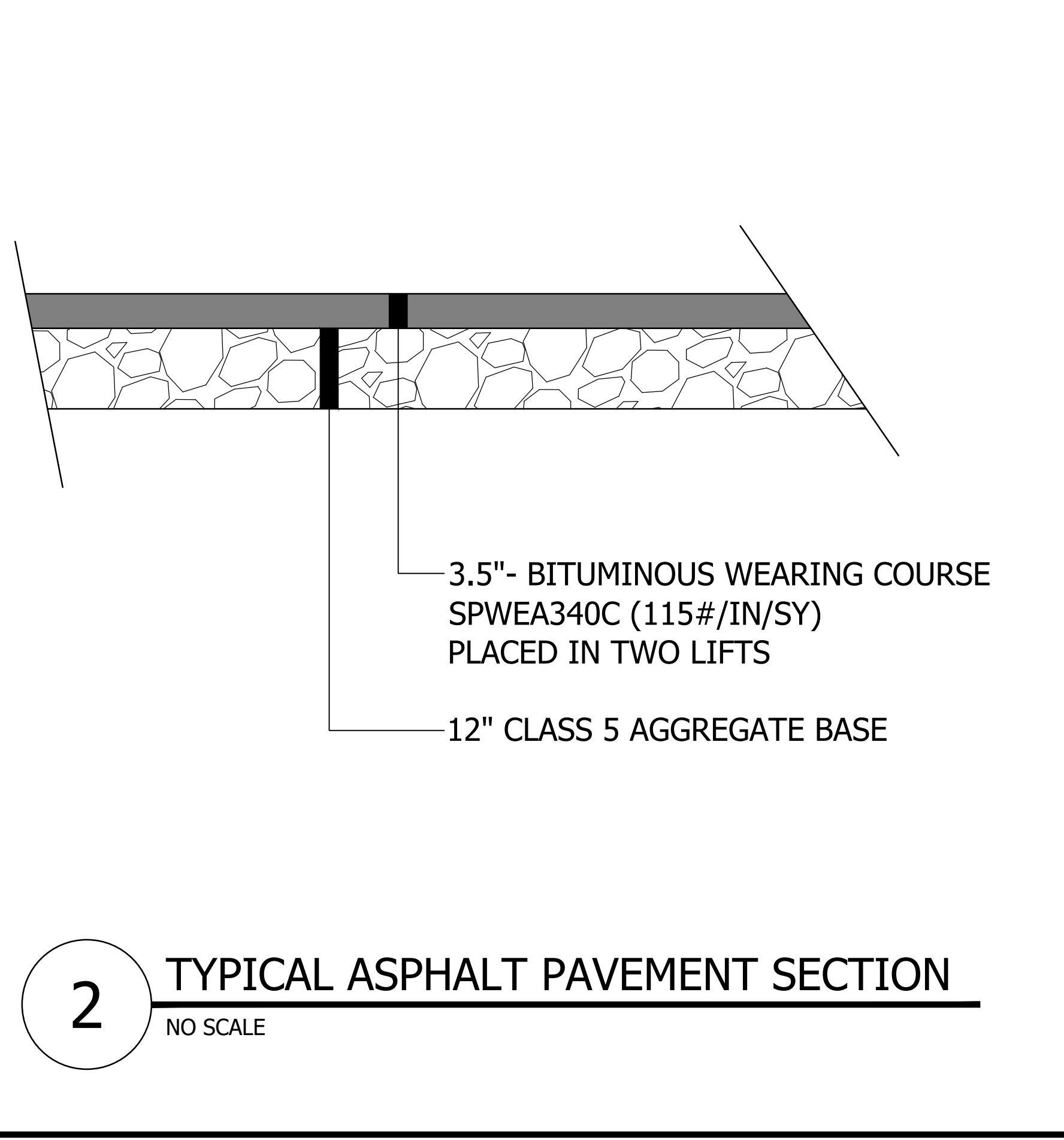
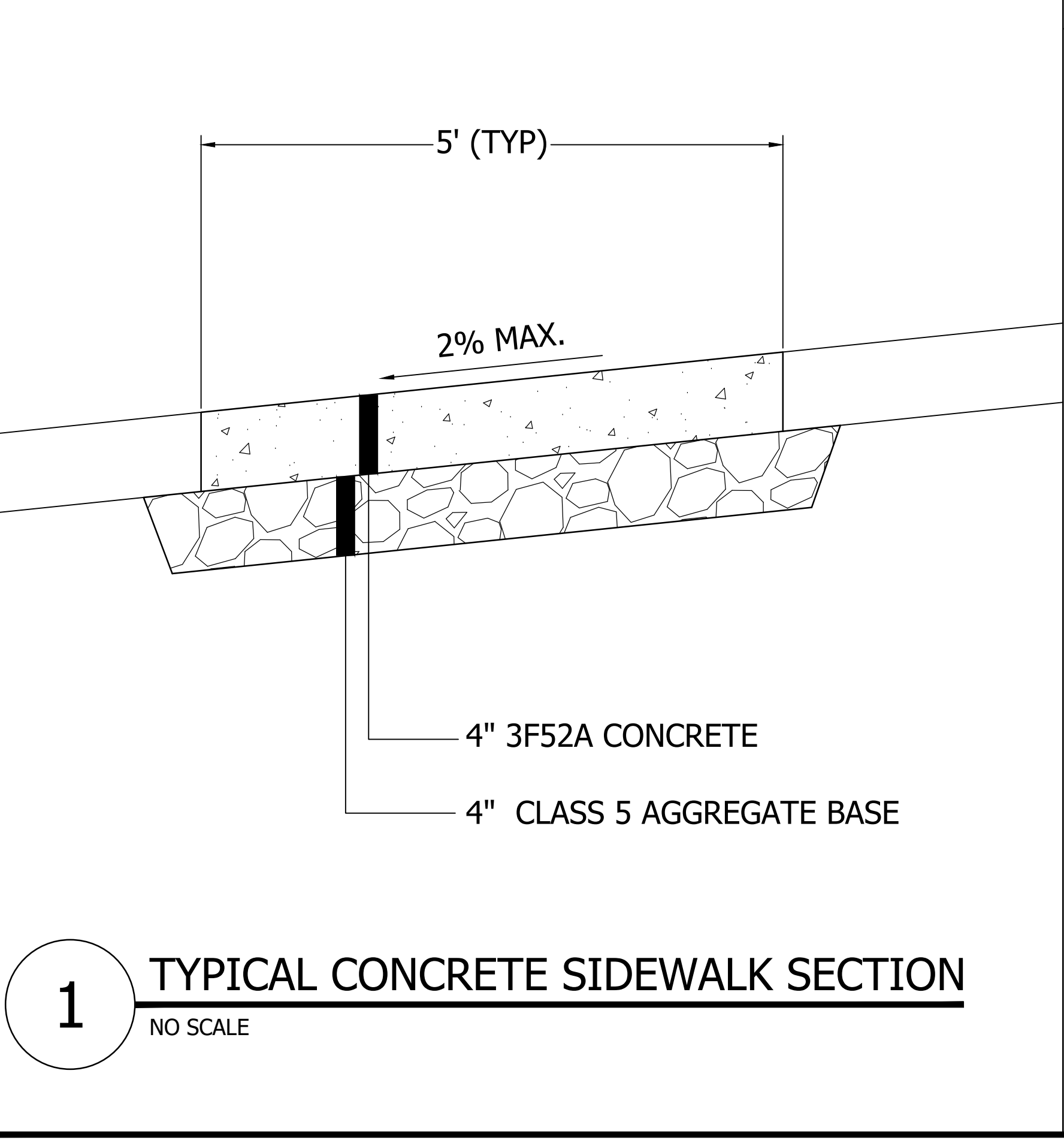

NO	REVISION	DATE
1	ADD 1	11/26/23
2	PR 9	7/11/24

SURVEY	EAB
DRAWN	GDS
DESIGNED	LPS
CHECKED	BP
APPROVED	LPS
PROJ. NO.	193806047
SHEET NUMBER	CO03

Knetic X Xcavating LLC

710 Pine Street
Prescott, WI
54021
Office: 715-262-3261
Mobile: 651-238-7811

Site Work Proposal

Proposal Date: 7-14-24

Questions Try: 651-238-7811 Nick's Cell

Project: Spring Lake Park City Hall Renovation/Expansion PR-9 Spring Lake Park, MN Architect: Stantec	Bid Date: 7-24-24
--	--------------------------

Note* This project is being bid without a geo-technical report. Knetic Xcavating is bidding this project with the assumption that there will not need to be any importation of sub-soil for construction of the building pad/parking area, nor will there be any rock excavating needed. If there is the need for any soil correction, rock excavation, or importation or exportation of any materials other than what are listed below additional charges will apply.

Site Work

- Saw cut up to 82 linear feet of concrete/bituminous
- Remove and dispose of up to 500 square feet of bituminous
- Remove and dispose of up to 1-foot of existing fill in new bituminous path area up to 500 square feet
- Import, place, and compact up to 1-foot of class 5 gravel for new bituminous patch up to 500 square feet

Note* Shoring is NOT included. Any shoring is to be done by others.

Note** De-watering is NOT included. Any de-watering is to be done by others.

Note*** Landscaping is NOT included

Note**** Hazardous Material removal is NOT included.

Note***** Surveying/staking is NOT included-

Note***** Rock Excavation is NOT included.

Note***** Permits are NOT included.

Note***** **Hazardous materials survey and abatement are NOT included**

Note***** **Soil correction is NOT included**

Note***** **Price quoted is based upon drawings dated 7-11-24. Drawings and specifications after 7-11-24 are not included in the price quoted below.**

Total \$3173.00

Prices are for exterior work only

Excluded Items:

Any temporary facilities during construction, patching of any paving, new bituminous, soil testing, shoring or underpinning, disconnection or permanent protection of any existing utilities, site layout, batter boards, rock excavation, or any additional excavation or imported soils needed to correct any existing subsoil conditions deemed unsatisfactory by the engineer.

Signed by: _____

A.R.C. Paving Inc.

P.O. 627

Willernie Mn 55090

Estimate

Date	Estimate #
12/12/2023	57

Name / Address
Construction Results Corporation 5465 Hwy 169 N Plymouth Mn 55442

			Project
Description	Qty	Rate	Total
Final grade and pave approx. 4500 sq.ft. parking lot addition and sewer connection patch. Areas to be paved at 3.5" finished depth (2" base and 1.5" wear). Stripe areas according to drawing following paving. *Assumed class 5 prep and transition cuts to be made by excavation contractor. *Pricing based on \$3.75 per sq.ft. Project: Spring Lake Park City Hall Added 365 sq.ft. of area PR #9 Pricing		1,368.75 1,368.75	1,368.75 1,368.75
		Total	\$20,743.75