



City of Spring Lake Park Feasibility Report

2022 Street Improvements Project Hayes Avenue NE, 80th Avenue NE, and Garfield Avenue NE.

September 2021

Stantec Project No. 193805383



Stantec Consulting Services Inc.
733 Marquette Avenue, Suite 1000
Minneapolis MN 55402
Tel: (612) 712-2000

September 7, 2021

Honorable Mayor and City Council
City of Spring Lake Park
1301 81st Avenue NE
Spring Lake Park, MN 55432-2116

Re: Feasibility Report
2022 Street Improvements Project
Stantec Project No.: 193805383

Dear Mayor and Council:

Submitted herewith is our Report on providing improvements on:

- Hayes Avenue NE,
- 80th Avenue NE, and
- Garfield Avenue NE.

The streets are in the Spring Lake Estates neighborhood. The report was authorized by the City Council on July 19, 2021 (Resolution 21-27).

The Report includes a discussion of the existing condition of the streets, as well as a description of the improvements recommended for inclusion in this project. The improvements primarily include street rehabilitation and select repairs to the existing public storm sewer system.

A planning-level cost estimate for the recommended improvements is also included in the Report, along with a possible method of cost allocation for division of cost between the City, properties that will benefit from the improvements.

We would be pleased to meet with the City Council and Staff at any mutually convenient time to discuss the findings of this Report.

Sincerely,
STANTEC

Phil Gravel, City Engineer

I hereby certify that this report, plan, or specification was prepared by me or under my direct supervision and that I am a duly Registered Professional Engineer under the laws of the State of Minnesota.

Phil Gravel, P.E.

Date: September 7, 2021 Registration No. 19864

Table of Contents

Letter of Transmittal.....	1
Table of Contents.....	3
Executive Summary.....	4
Introduction and Existing Roadway Conditions.....	4
Roadway Design Considerations.....	5
Storm Sewer.....	5
Water Main.....	5
Sanitary Sewer.....	5
Permits.....	6
Project Schedule.....	6
Opinion of Probable Project Costs.....	7
Cost Allocation and Assessments.....	7
City Assessment Policy and Practice.....	7
Assessment Rate Assumptions for This Project.....	8
Assessment Rate Calculations.....	8
Proposed Assessment Rates.....	8
Area to be Assessed.....	8
Conclusions and Recommendations.....	9

Figure 1 – Project Location – Area To Be Assessed

Figure 2 – Typical Section

Appendix A – Opinions of Probable Project Costs

Appendix B – Preliminary Assessment Roll

Executive Summary

Since the late 1990's, the City of Spring Lake Park has undertaken a comprehensive city-wide street maintenance program. Street Improvement Projects were completed from 2002-2015. This report presents information for completing improvements on the remaining street segments in the Spring Lake Estates area of the City:

- Hayes Avenue NE,
- 80th Avenue NE, and
- Garfield Avenue NE.

The proposed improvements presented herein are similar to the improvements that were completed in 2014 and 2015. It is proposed to complete the project in one construction season.

The estimated total project cost is \$689,000. The estimated amount to be assessed is \$258,345. The net estimated City share of the project is \$430,655.

The proposed assessment rates presented herein are consistent with the city's assessment practice. The proposed assessment rates are similar to rates from previous projects when adjusted for inflation.

If the Council wishes to proceed with the project, the next steps would include preparation of a detailed financial analysis, sharing information with the public, and preparation of plans and specifications.

Introduction and Existing Roadway Conditions

In July of 2021, the City Council authorized preparation of a Feasibility Report to complete a street improvements project on the streets in the project area.

The streets in the project area are existing urban, bituminous roadways with concrete curb and gutter. The streets are 34-feet wide (back of curb to back of curb) and were originally constructed in 1984-1985. Per the original project plans, the streets were constructed with 4-inches of aggregate base and 3-inches of bituminous.

Following is a summary of the characteristics of the existing streets:

Street Width	34-feet (back of curb to back of curb)
Number of Driving Lanes	2 (one in each direction)
Parking	Allowable
Sidewalk	None

Based on a current inspection, the existing curb and gutter along the roads is generally in fair condition, with minor cracks and settlements. Areas of curb recommended for replacement as part of this project will primarily occur storm sewer catch basin locations. Various other spot curb repairs will be minor.

Storm sewer catch basin structures, located in the existing gutter, are in need of repair or replacement throughout the project. The storm sewer piping which connects the catch basins to the main storm sewer lines is generally in fair shape.

Roadway Design Considerations

STREET SECTION

According to available record documents, the existing bituminous section on the streets in the project area is 3.0-inches of bituminous over 4.0-inches of Class 5 aggregate. The subgrade is silty sand.

The proposed construction will include reclamation of the existing bituminous. This process involves grinding the existing bituminous into a granular material to use as a base for new bituminous. The proposed design section will include 4.0-inches of new bituminous over 8-inches of Class 5 or reclaimed material.

Storm Sewer

The existing storm sewer structures have been inspected by the Public Works Director to determine pipe conditions and identify necessary repairs.

The majority of the catch basins and leads throughout the project are deemed to be in acceptable condition. Some catch basin structures will be removed and replaced with new structures. All storm sewer structures will receive new castings and concrete adjustment rings.

Water Main

The existing water distribution system in the project area is deemed to be in an acceptable condition based on the history of past repairs in the neighborhood. The existing water main is 6-inches in diameter.

No significant improvements or extensions will be made to the water distribution system as part of this project. Work on the system will be limited to adjustment of valve boxes or hydrants as part of the street improvements, and the addition of gate valves in key locations determined by the Public Works Director.

Sanitary Sewer

Sanitary sewer mains exist along the length of the streets in the project area. The existing sewer mains are 8-inch diameter and are made Polyvinyl Chloride (PVC).

No extensions or upgrades to the sanitary sewer system are proposed as part of this project. Any sanitary sewer work included in this project would be only for the maintenance or repair of the existing sanitary sewer system.

Permits

To construct the proposed improvements discussed herein, it is anticipated the following permits will need to be obtained prior to the start of construction:

- Minnesota Pollution Control Agency: A NPDES General Storm Water Permit for Construction Activities will be required from the Minnesota Pollution Control Agency.
- Rice Creek Watershed District (RCWD):
Per the current RCWD rules, an erosion and sediment control plan will be required, but a Rule C permit should not be required:
[RCWD Rule C - Stormwater Management](#)
 - Construction activity other than Public Linear projects that results in 10,000 square feet or more of new or reconstructed impervious surface area. The following are exceptions to this threshold:
 - Mill, Reclamation & Overlay project areas.
 - Sidewalks and trails 10 feet wide or less with 5 feet of vegetated area down-gradient.
 - Development on an individual lot within a residential subdivision if it conforms to a development plan approved by the district.
 - Water quality treatment and rate control requirements do not apply to single family residential subdivisions creating 7 or fewer lots that establish no new public roadway or private roadway serving 3 or more lots.

Project Schedule

The following schedule outlines the major project tasks necessary to complete the project.

Authorize Preparation of Feasibility Report	July 19, 2021
Accept Feasibility Report and Call for Public Improvement Hearing	September 7, 2021
Public Improvement Hearing	October 4, 2021
Authorize Preparation of Plans and Specifications	October 18, 2021
City Council Approve Plans and Specifications	December 6, 2021
Open Bids	January 2022
Declare Costs to Be Assessed and Order Final Assessment Roll	February 7, 2022
Receive Assessment Roll and Order Assessment Hearing	February 22, 2022
Public Assessment Hearing	March 21, 2022
Award Contract (Award Bids)	March 21, 2022
Begin Construction	May 2022
Final Wear Course Paving	August 2022

Opinion of Probable Project Costs

An opinion of Probable Project Costs has been prepared for the proposed improvements based on current information, including an allowance for engineering, administrative fees, financing. Costs are not included for capitalized interest that will accrue during the construction period. It is anticipated that a separate financing analysis of the project will be prepared when funding and financing decisions are made.

A detailed list of the estimated improvement costs is included in an attachment to this report. The total estimated project cost is \$689,000. The project cost estimate will be updated and refined as part of the design process.

Cost Allocation and Assessments

The costs for the improvements will be recovered through a combination of assessment to the properties benefiting from this project and City funding.

CITY ASSESSMENT POLICY AND PRACTICE

The City Council adopted Resolution 98-48 on November 16, 1998 establishing a Pavement Management Policy. The City adopted an addendum to the policy in January 1999 to clarify construction issues. Resolution 98-48 established assessment policy to be applied to street improvement projects. This policy provides that commercial, industrial, school, and church properties shall pay 100 percent of the actual cost based on the front footage of the property adjacent to the streets being improved. For purposes of this report, public lands are treated in a manner identical to school and church. This includes City-owned properties.

In residential areas, the policy says that costs will be split, with approximately 45% being assigned to the residential properties, and approximately 55% being funded by the City. The assignment of costs to residential properties will be made based on the total number of equivalent units involved in the project. For this method, a single-family lot is assigned a value of one unit. Multiple housing lots (if any) are counted as proportions of equivalent single-family lots. Duplex units are counted at a rate of 0.8 single-family lots per unit, town homes are counted at a rate of 0.6 single-family lots per unit, and apartments are counted as 0.4 single-family lots per unit. No differentiation will be made between attached and detached town home units.

In accordance with the Pavement Management Policy, all costs of public utility improvements incurred on this project, including sanitary sewer, water main, and storm sewer, will be completely funded by the City, with no portion assessed.

Residential lots are only to be assessed for one street improvement project. Therefore, corner lots that have been assessed for a previous street improvement project are not assessed twice. No corner lots within the 2022 Street Improvements Project area have previously been assessed.

ASSESSMENT RATE ASSUMPTIONS FOR THIS PROJECT

The streets in the 2022 Street Improvements project are typical residential streets with no oversizing of the street width or street section included.

ASSESSMENT RATE CALCULATIONS

To determine the proposed assessment rate for this project, an Opinion of Probable Construction Costs estimate was prepared. The final assessment rate will be based on costs received as part of a competitive construction bid for the project.

The total estimated project cost is \$689,000. However, the city assessment practice does not include all project costs in the assessments (no storm, sanitary, or water main costs). The net assessable cost for the project is \$574,100. The City assessment practice calls for assessing 45% of the net assessable project cost.

45-percent of \$574,100 is \$258,345.

There are 76 assessable parcels in the project area. \$258,345 divided by 76 parcels equals \$3,399.28 per parcel. For purposes of this report and related discussions, the amount can be rounded to \$3,400 per parcel.

Estimated Per Parcel Assessment: $\$258,345 \div 76 \text{ parcels} = \$3,400 \text{ per parcel}$

PROPOSED ASSESSMENT RATES

Based on the assumptions and methodology presented above, the resulting estimated assessment rates for a standard residential street are shown below. An analysis of financing and funding options should be prepared based on the information contained herein.

PROPOSED ASSESSMENT RATES: 2022 STREET IMPROVEMENTS PROJECT

Unit Assessment Rate	\$3,400 / parcel
----------------------	------------------

ESTIMATED TOTAL ASSESSMENTS: 2022 STREET IMPROVEMENTS PROJECT

Per Parcel Assessments	<u>\$258,345</u>
Total Estimated Project Assessments	\$258,345

AREA TO BE ASSESSED

The area proposed to be assessed included the parcels adjacent to the improvements. The parcels are located in the Spring Lake Estates development. The area to be assessed is shown on Figure 1 of this report. The parcels are listed in the Preliminary Assessment Roll.

Conclusions and Recommendations

This Feasibility Report was ordered by the City Council based on the age and condition of streets included in the project. Through the course of this Report, it has been determined that a capital improvement project to reconstruct these streets should be undertaken. The project is necessary, cost effective and feasible.

A project schedule has been presented for completing the improvements in one construction season.

The following recommendations are presented for consideration by the Spring Lake Park City Council:

- A financing analysis for the project should be prepared.
- The City should accept this Report and adopt it as a guide for completion of the proposed improvements.
- The City should consider assessing a portion of the cost of this project to abutting properties in accordance with approved City policy.
- The City should hold informal neighborhood open house meetings to present the available information to the property owners along the streets included in the project.
- The City should schedule a public improvement hearing to receive input on the proposed improvements.
- Upon completion of the public hearing, if the City wishes to proceed, the City Council should formally order the project.

Plot Date: 08/23/2021 - 10:08am
Project Name: Spring Lake
User: 193805383_CAD/DMG
Xref: 193805383_X3V

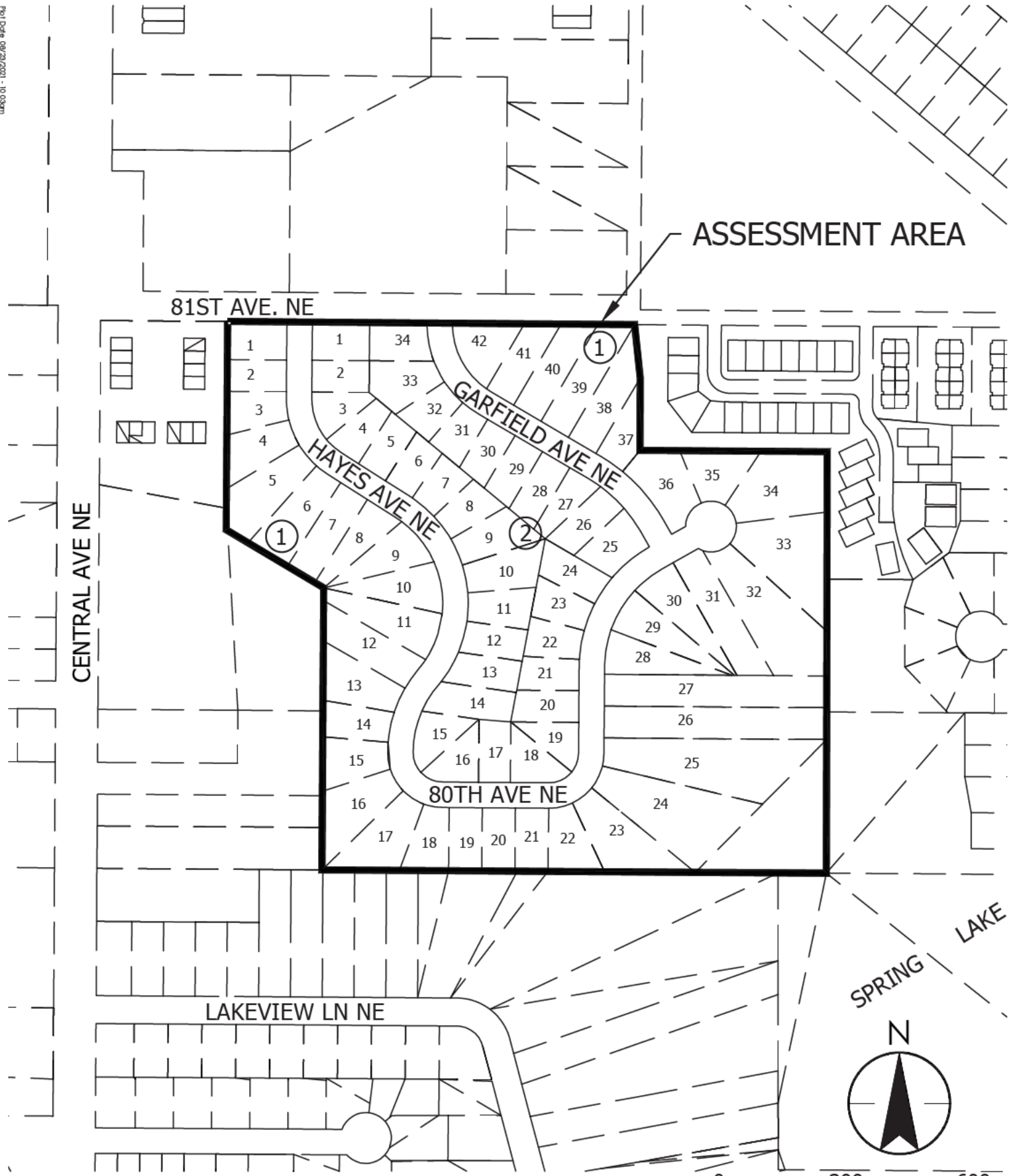

LOCATION PLAN - ASSESSMENT AREA

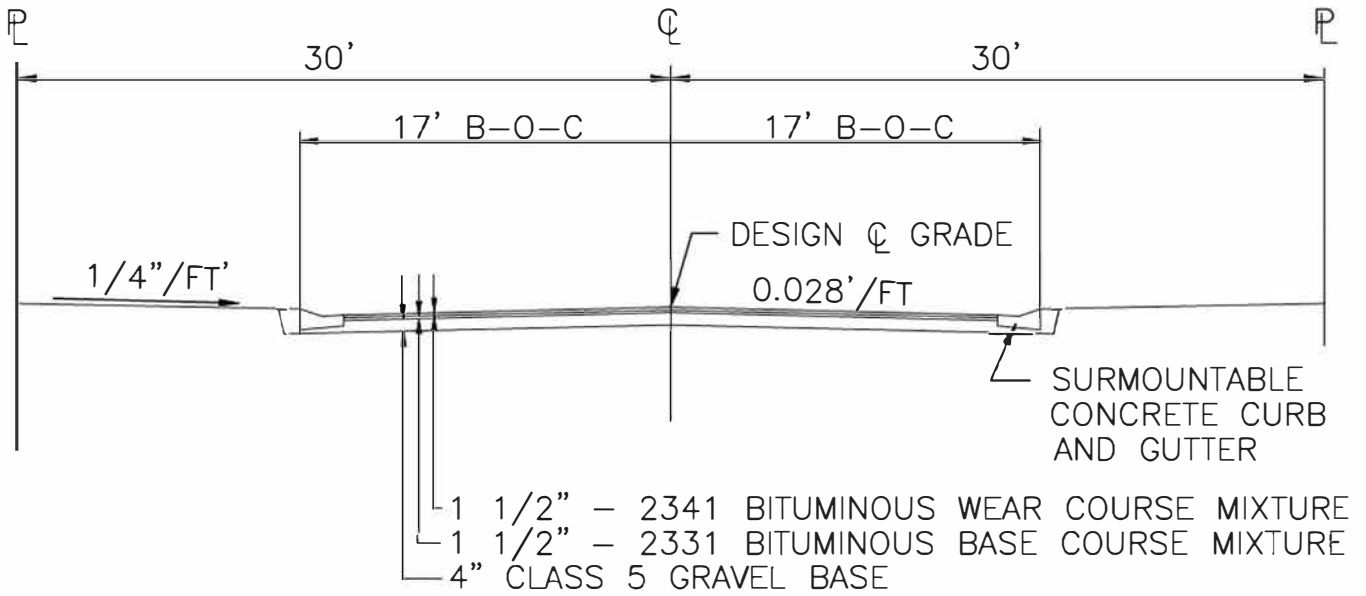

EXIST. TYPICAL SECTION

NO SCALE

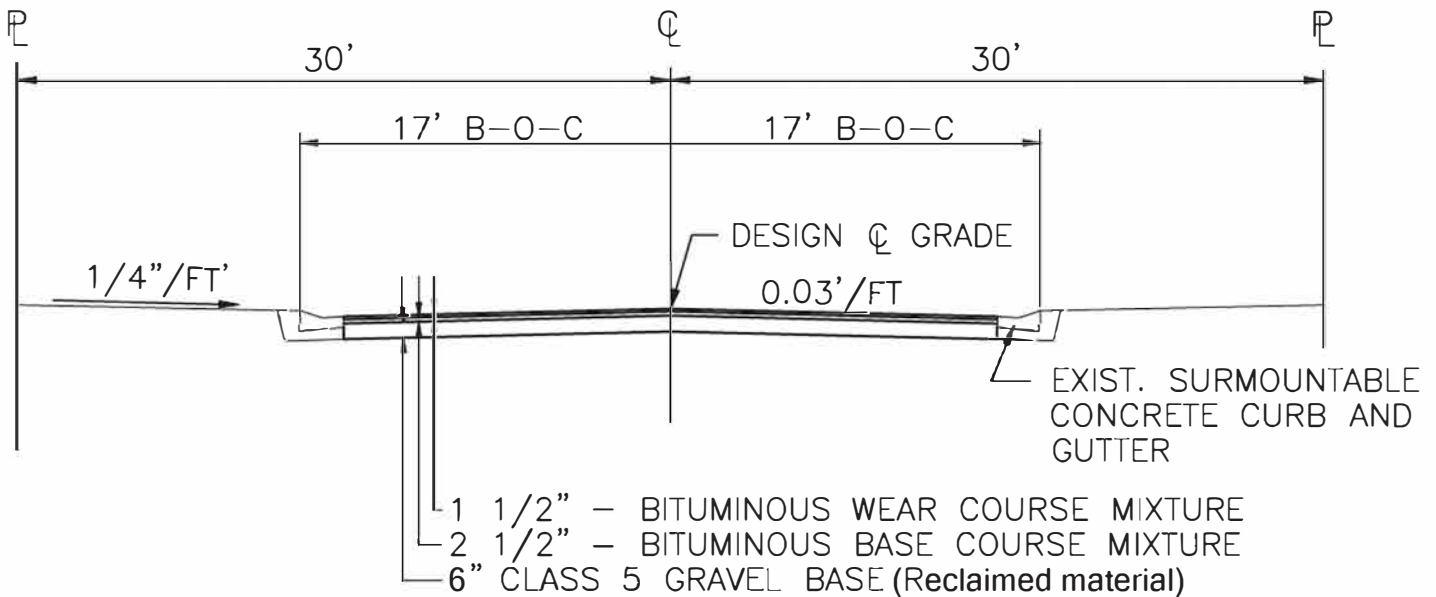

PROPOSED TYPICAL SECTION

NO SCALE

TYPICAL SECTIONS

SPRING LAKE PARK, MN
2022 STREET IMPROVEMENTS

FIGURE: 2



733 Marquette Avenue, Suite 1000
Minneapolis, MN 55402
www.stantec.com

DATE 8-23-21

PROJ. NO. 193805383



**OPINION OF PROBABLE PROJECT COSTS
2022 STREET IMPROVEMENTS PROJECT**

PROJECT NO. 193805383

SPRING LAKE PARK, MINNESOTA

September 2022

No.	Item	Units	Qty	Unit Price	Total Price
BASE BID					
1	MOBILIZATION	LS	1 \$	25,000.00 \$	25,000.00
2	TRAFFIC CONTROL	LS	1 \$	5,000.00 \$	5,000.00
3	EROSION AND SEDIMENT CONTROL	LS	1 \$	10,000.00 \$	10,000.00
4	REMOVE STRUCTURE (STORM)	EACH	2 \$	1,500.00 \$	3,000.00
5	REMOVE CURB AND GUTTER	LIN FT	650 \$	20.00 \$	13,000.00
6	REMOVE BITUMINOUS STREET PAVEMENT (P)	SQ FT	104,100 \$	0.50 \$	52,050.00
7	REMOVE BITUMINOUS NON-STREET PAVEMENT	SQ FT	150 \$	1.00 \$	150.00
8	SAWCUT BITUMINOUS PAVEMENT	LIN FT	30 \$	5.00 \$	150.00
9	ADJUST EXISTING VALVE BOX	EACH	5 \$	300.00 \$	1,500.00
10	ADD VALVE TO EXIST HYDRANT LEAD	LS	7 \$	4,000.00 \$	28,000.00
11	ADJUST EXISTING MANHOLE FRAME, CASTING, AND RINGS	EACH	25 \$	1,000.00 \$	25,000.00
12	ADJUST EXISTING CB WITH NEW CASTING, FRAME AND RINGS	EACH	5 \$	1,000.00 \$	5,000.00
13	COMMON EXCAVATION - STREETS (P)	CU YD	2850 \$	15.00 \$	42,750.00
14	LOAM TOPSOIL BORROW (LV)	CU YD	100 \$	40.00 \$	4,000.00
15	AGGREGATE BASE (CV) CLASS 5 (ROADWAY)	CU YD	2840 \$	28.00 \$	79,520.00
16	AGGREGATE BASE (CV) CLASS 5 (DRIVEWAY)	CU YD	5 \$	100.00 \$	500.00
17	TYPE SP 9.5 WEARING COURSE MIXTURE (3,B) - STREET	TON	1050 \$	83.00 \$	87,150.00
18	TYPE SP 12.5 NON WEARING COURSE MIXTURE (3,B) - STREET	TON	1750 \$	70.00 \$	122,500.00

No.	Item	Units	Qty	Unit Price	Total Price
19	TYPE SP 9.5 WEARING COURSE MIXTURE (3, B) - DRIVEWAY	TON	4	\$ 200.00	\$ 800.00
20	PREPARE SURFACE FOR WEAR PAVING	LS	1	\$ 5,000.00	\$ 5,000.00
21	TACK COAT	GAL	725	\$ 3.00	\$ 2,175.00
22	CONCRETE CURB & GUTTER DESIGN B618	LIN FT	650	\$ 25.00	\$ 16,250.00
23	18" RC PIPE SEWER DESIGN 3006 CLASS V	LIN FT	60	\$ 100.00	\$ 6,000.00
24	CONSTRUCT DRAINAGE STRUCTURE DESIGN 48-4020	EACH	3	\$ 2,500.00	\$ 7,500.00
25	CONNECT TO EXISTING STORM SEWER	EACH	3	\$ 500.00	\$ 1,500.00
26	CONNECT TO EXISTING STORM STRUCTURE (CORE DRILL)	EACH	1	\$ 935.00	\$ 935.00
27	BULKHEAD EXISTING STORM SEWER	EACH	2	\$ 500.00	\$ 1,000.00
28	2-INCH THICK POLYSTYRENE INSULATION	SQ FT	80	\$ 4.00	\$ 320.00
29	SOD	SQ YD	650	\$ 5.00	\$ 3,250.00
	TOTAL ESTIMATED CONSTRUCTION				\$ 549,000.00
	CONTINGENCY				\$ 25,000.00
	LEGAL, ADMINISTRATIVE, AND ENGINEERING				\$ 115,000.00
	TOTAL ESTIMATED PROJECT COST				\$ 689,000.00

PRELIMINARY ASSESSMENT ROLL
2022 STREET IMPROVEMENTS PROJECT
 SPRING LAKE PARK, MINNESOTA

September 2022

NAME	PARCEL ID#	ADDRESS	PROPOSED ASSESSMENT
PHAM TRUC B & HOA T	PIN: 01-30-24-42-0035	8017 GARFIELD ST NE	\$ 3,400.00
JOHNSON KURT E & JEAN M	PIN: 01-30-24-42-0055	8025 HAYES ST NE	\$ 3,400.00
NEHRING, ROBERT IVAN	PIN: 01-30-24-42-0052	8039 HAYES ST NE	\$ 3,400.00
BOHL, PETER J	PIN: 01-30-24-42-0023	8006 HAYES ST NE	\$ 3,400.00
HOWELL GREGORY G & D J KANIS-	PIN: 01-30-24-42-0074	8090 GARFIELD ST NE	\$ 3,400.00
BREISTER-BOLF, SUSAN	PIN: 01-30-24-42-0061	8008 GARFIELD ST NE	\$ 3,400.00
LATHE, KARI A	PIN: 01-30-24-42-0056	8019 HAYES ST NE	\$ 3,400.00
NOVY, BRADLEY J	PIN: 01-30-24-42-0028	1452 80TH AVE NE	\$ 3,400.00
BISCH, ROSE ANN	PIN: 01-30-24-42-0057	8015 HAYES ST NE	\$ 3,400.00
LOESCH WILLIAM & LEEANN	PIN: 01-30-24-42-0024	8000 HAYES ST NE	\$ 3,400.00
MOHAMOUD, HODON A	PIN: 01-30-24-42-0059	1455 80TH AVE NE	\$ 3,400.00
DIAZ, TANYA M	PIN: 01-30-24-42-0018	8036 HAYES ST NE	\$ 3,400.00
KHANGKYI, TSERING S	PIN: 01-30-24-42-0033	8005 GARFIELD ST NE	\$ 3,400.00
BOROWITZ, PETER	PIN: 01-30-24-42-0068	PO BOX 32341	\$ 3,400.00
EGGERT TRUSTEE, JOHN G	PIN: 01-30-24-41-0043	8065 GARFIELD ST NE	\$ 3,400.00
HYDEMAN, JOANN E	PIN: 01-30-24-42-0063	8020 GARFIELD ST NE	\$ 3,400.00
STIMPEL, RICHARD	PIN: 01-30-24-42-0044	8085 HAYES ST NE	\$ 3,400.00
HAUKOM, JOSHUA R	PIN: 01-30-24-41-0039	8041 GARFIELD ST NE	\$ 3,400.00
LAMPI, SHANE A	PIN: 01-30-24-42-0070	8072 GARFIELD ST NE	\$ 3,400.00
TEEKASINGH C & SINGH G	PIN: 01-30-24-42-0048	8049 HAYES ST NE	\$ 3,400.00
WESTLING, ROBIN K	PIN: 01-30-24-42-0011	8078 HAYES ST NE	\$ 3,400.00
CHESLEY RENAE E	PIN: 01-30-24-42-0019	8030 HAYES ST NE	\$ 3,400.00
MCMAHON TERRANCE & JERRI	PIN: 01-30-24-42-0038	8073 GARFIELD ST NE	\$ 3,400.00
GAASLAND, KRISTIAN PEDAR	PIN: 01-30-24-42-0062	8016 GARFIELD ST NE	\$ 3,400.00
POLKINGHORNE, JEANNETTE	PIN: 01-30-24-42-0064	8024 GARFIELD ST NE	\$ 3,400.00
POLAND GUY B & BEVERLY N	PIN: 01-30-24-42-0040	8085 GARFIELD ST NE	\$ 3,400.00
BANICK-OLIVEROS MEGAN ELIZABETH	PIN: 01-30-24-42-0041	8089 GARFIELD ST NE	\$ 3,400.00
RETKA, ANITA J	PIN: 01-30-24-42-0042	8097 GARFIELD ST NE	\$ 3,400.00
DOMINO MICHAEL L & DIANE C	PIN: 01-30-24-41-0040	8049 GARFIELD ST NE	\$ 3,400.00
SALO LORI J	PIN: 01-30-24-42-0069	8068 GARFIELD ST NE	\$ 3,400.00
AHMED, ABDI FARAH	PIN: 01-30-24-42-0014	8060 HAYES ST NE	\$ 3,400.00
LOEGERING JAMES M & SANDRA M	PIN: 01-30-24-42-0010	8084 HAYES ST NE	\$ 3,400.00
MARTIN, KENNETH L	PIN: 01-30-24-42-0067	8050 GARFIELD ST NE	\$ 3,400.00
WONG-ELDREDGE, LICHEEH	PIN: 01-30-24-42-0051	8041 HAYES ST NE	\$ 3,400.00
KHANGCHUNG, TINLEY C	PIN: 01-30-24-42-0013	8066 HAYES ST NE	\$ 3,400.00
DESHAW, KIMBERLY A	PIN: 01-30-24-42-0036	8021 GARFIELD ST NE	\$ 3,400.00
FOSSUM TIMOTHY & JANET	PIN: 01-30-24-41-0037	8033 GARFIELD ST NE	\$ 3,400.00
TRAVIS RONALD G & JANET L	PIN: 01-30-24-42-0075	8094 GARFIELD ST NE	\$ 3,400.00
LECY JOHN A & GALE E	PIN: 01-30-24-42-0050	8045 HAYES ST NE	\$ 3,400.00
HAFERMAN, JACOB	PIN: 01-30-24-42-0012	8072 HAYES ST NE	\$ 3,400.00
WORKMAN, TIMOTHY S	PIN: 01-30-24-42-0045	8075 HAYES ST NE	\$ 3,400.00
HAMMER, MARK F	PIN: 01-30-24-42-0025	1410 80TH AVE NE	\$ 3,400.00
ALHAMMOURI, SHARIF	PIN: 01-30-24-42-0060	1477 80TH AVE NE	\$ 3,400.00
SCAVO, ANTHONY M	PIN: 01-30-24-42-0022	8012 HAYES ST NE	\$ 3,400.00
LAWRENCE, BRIAN J	PIN: 01-30-24-42-0020	8024 HAYES ST NE	\$ 3,400.00
SHIMANSKI TRUSTEE, MARY LOU	PIN: 01-30-24-41-0036	8025 GARFIELD ST NE	\$ 3,400.00
POGORELY RICHARD & DOROTHY	PIN: 01-30-24-42-0053	8035 HAYES ST NE	\$ 3,400.00
OSTERLUND JENNIFER L & JAY P	PIN: 01-30-24-42-0016	8048 HAYES ST NE	\$ 3,400.00

RADISEWITZ, GWEN M	PIN: 01-30-24-42-0049	8047 HAYES ST NE	\$ 3,400.00
KOWALZEK JEFFREY & TAMMY	PIN: 01-30-24-42-0076	8098 GARFIELD ST NE	\$ 3,400.00
EYER, GLORIA	PIN: 01-30-24-42-0072	8086 GARFIELD ST NE	\$ 3,400.00
GAPINSKI, SANDRA KIM	PIN: 01-30-24-42-0030	1480 80TH AVE NE	\$ 3,400.00
CAFFARI, JULIE ANNE	PIN: 01-30-24-42-0054	8031 HAYES ST NE	\$ 3,400.00
EICHER, ROBERT W	PIN: 01-30-24-42-0015	8054 HAYES ST NE	\$ 3,400.00
HODET, MICHAEL PRESTON	PIN: 01-30-24-42-0071	8082 GARFIELD ST NE	\$ 3,400.00
LEE RYAN	PIN: 01-30-24-42-0029	1466 80TH AVE NE	\$ 3,400.00
LUECK, JENNIFER K	PIN: 01-30-24-42-0032	8001 GARFIELD ST NE	\$ 3,400.00
JOHNSON LEE R & NANCY J	PIN: 01-30-24-42-0058	1433 80TH AVE NE	\$ 3,400.00
MILLER TRUSTEE, SANDRA ANN	PIN: 01-30-24-41-0038	8037 GARFIELD ST NE	\$ 3,400.00
BOETTCHER TRUSTEE, DOREEN LOUISE	PIN: 01-30-24-42-0027	1438 80TH AVE NE	\$ 3,400.00
AALUND, STEVEN G	PIN: 01-30-24-42-0026	1424 80TH AVE NE	\$ 3,400.00
CALL JOSEPH RICHARD	PIN: 01-30-24-42-0034	8009 GARFIELD ST NE	\$ 3,400.00
SAINIO DANIEL	PIN: 01-30-24-42-0073	8088 GARFIELD ST NE	\$ 3,400.00
HARTSOOK JANICE J & GOTSCH P	PIN: 01-30-24-42-0046	8063 HAYES ST NE	\$ 3,400.00
WILLIAMS CLARE L & STEVEN B	PIN: 01-30-24-42-0037	8069 GARFIELD ST NE	\$ 3,400.00
MONSON-HOKENSON S W & L A	PIN: 01-30-24-42-0066	8030 GARFIELD ST NE	\$ 3,400.00
HAGEN PAMELA S	PIN: 01-30-24-42-0017	8042 HAYES ST NE	\$ 3,400.00
ELBARHAMTOSHI, JOULAN A	PIN: 01-30-24-41-0042	8057 GARFIELD ST NE	\$ 3,400.00
HAGEN, ASHLEY J	PIN: 01-30-24-42-0047	8055 HAYES ST NE	\$ 3,400.00
PUPO-QUIALA, WILLIAM	PIN: 01-30-24-42-0043	8091 HAYES ST NE	\$ 3,400.00
LARSON TRUSTEE, ROBYN F	PIN: 01-30-24-42-0031	1494 80TH AVE NE	\$ 3,400.00
DUFEK PATRICK A & LYNETTE J	PIN: 01-30-24-42-0021	8018 HAYES ST NE	\$ 3,400.00
DOLMA, YONTEN	PIN: 01-30-24-42-0065	8028 GARFIELD ST NE	\$ 3,400.00
WYATT, JACQUELINE R	PIN: 01-30-24-41-0041	8053 GARFIELD ST NE	\$ 3,400.00
JONES CHRISTINE	PIN: 01-30-24-42-0039	8081 GARFIELD ST NE	\$ 3,400.00
DENYES TRUSTEE, SHIRLEY	PIN: 01-30-24-42-0009	8090 HAYES ST NE	\$ 3,400.00