



# Memorandum

---

**To:** Mayor Nelson and Members of the City Council

**From:** Daniel R. Buchholtz, MMC, Administrator, Clerk/Treasurer

**Date:** February 11, 2020

**Subject:** MSA Revision – 81<sup>st</sup> Avenue

Pursuant to the City Council's direction, staff has begun the process to amend the City's MSA system to remove a portion of 81<sup>st</sup> Avenue from the MSA system in an effort to reduce through-truck traffic along 81<sup>st</sup> Avenue between Trunk Highway 47 (University Avenue) and Trunk Highway 65.

Attached is a map showing the MSA map revisions being proposed to MnDOT. The City would revoke a portion of 81<sup>st</sup> Avenue between University Avenue and Terrace Road NE and a portion of the University Avenue Service Road between 83<sup>rd</sup> Avenue and 81<sup>st</sup> Avenue NE and replace it with a section of Able Street between 81<sup>st</sup> Avenue and Osborne Road. The remainder of the system will remain the same. The MSA system revisions were submitted to MnDOT on January 23, 2020.

Also included is a draft signage plan. We are seeking Council feedback regarding the placement of signs along 81<sup>st</sup> Avenue to inform drivers of the prohibition of trucks.

In addition, staff has created a preliminary draft of an ordinance amendment to Chapter 70 creating the legal restriction to operate trucks with a gross weight of more than 7000 pounds on the stretch of 81<sup>st</sup> Avenue between University Avenue Service Road and Terrace Road. Exceptions would be made for delivery trucks, garbage trucks and commercial vehicles permitted to be parked in residential districts in accordance with the City's zoning code.

We would appreciate the City Council's continued feedback in this proposed MSA map revision. If you have any questions, please don't hesitate to contact me at 763-784-6491.



## Daniel Buchholtz

---

**From:** Gravel, Phil <Phil.Gravel@stantec.com>  
**Sent:** Friday, January 24, 2020 8:21 AM  
**To:** Daniel Buchholtz  
**Subject:** FW: City of Spring Lake Park - MSA Revision  
**Attachments:** SLP\_MSA updates\_2020 revisions.pdf

Hi Dan- Just FYI, we've stated the system revision process with MnDOT State Aid that will get the west end of 81<sup>st</sup> Ave. off of the system and allow the city to post that segment as "no trucks". In March or April there will be council resolutions to pass. -Phil

### Phil Gravel

Principal  
Direct: 612-712-2053  
Stantec



The content of this email is the confidential property of Stantec and should not be copied, modified, retransmitted, or used for any purpose except with Stantec's written authorization. If you are not the intended recipient, please delete all copies and notify us immediately.

---

**From:** Dresel, Julie (DOT) <julie.dresel@state.mn.us>  
**Sent:** Thursday, January 23, 2020 4:09 PM  
**To:** Preston, Jeff <Jeff.Preston@stantec.com>  
**Cc:** Gravel, Phil <Phil.Gravel@stantec.com>  
**Subject:** RE: City of Spring Lake Park - MSA Revision

This is great for the first review. After we look at this a Metro, we forward it to Bill Lanoux at CO SALT. He will then send you a preliminary approval letter (if it is OK). That letter will give you instructions regarding your resolution.

*Julie Dresel, P.E.*  
Metro State Aid  
(651) 234-7780  
[julie.dresel@state.mn.us](mailto:julie.dresel@state.mn.us)



---

**From:** Preston, Jeff [<mailto:Jeff.Preston@stantec.com>]  
**Sent:** Thursday, January 23, 2020 3:59 PM  
**To:** Dresel, Julie (DOT) <[julie.dresel@state.mn.us](mailto:julie.dresel@state.mn.us)>  
**Cc:** Gravel, Phil <[Phil.Gravel@stantec.com](mailto:Phil.Gravel@stantec.com)>  
**Subject:** City of Spring Lake Park - MSA Revision

Hello Julie,  
Please find attached a figure outlining proposed MSA System revisions for the City of Spring Lake Park. Please let me know if you need further information to start the process. I understand there will be a need for a Council Resolution, but will get to that after State Aid concurs with the propose revision. Thanks again.

**Jeff Preston**  
Senior Engineer

Stantec  
733 Marquette Avenue Suite 1000  
Minneapolis MN 55402-2309

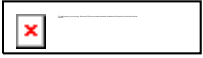

The content of this email is the confidential property of Stantec and should not be copied, modified, retransmitted, or used for any purpose except with Stantec's written authorization. If you are not the intended recipient, please delete all copies and notify us immediately.

File Date: 01/23/2020 - 2:47pm  
 Drawing Name: K:\Client\State\Provisional\del\_min\Spring Lake Park\Certification of MSA\MSA\_2020\System Revision\_SLP\_MSA\_updates\_2020.dwg  
 User:

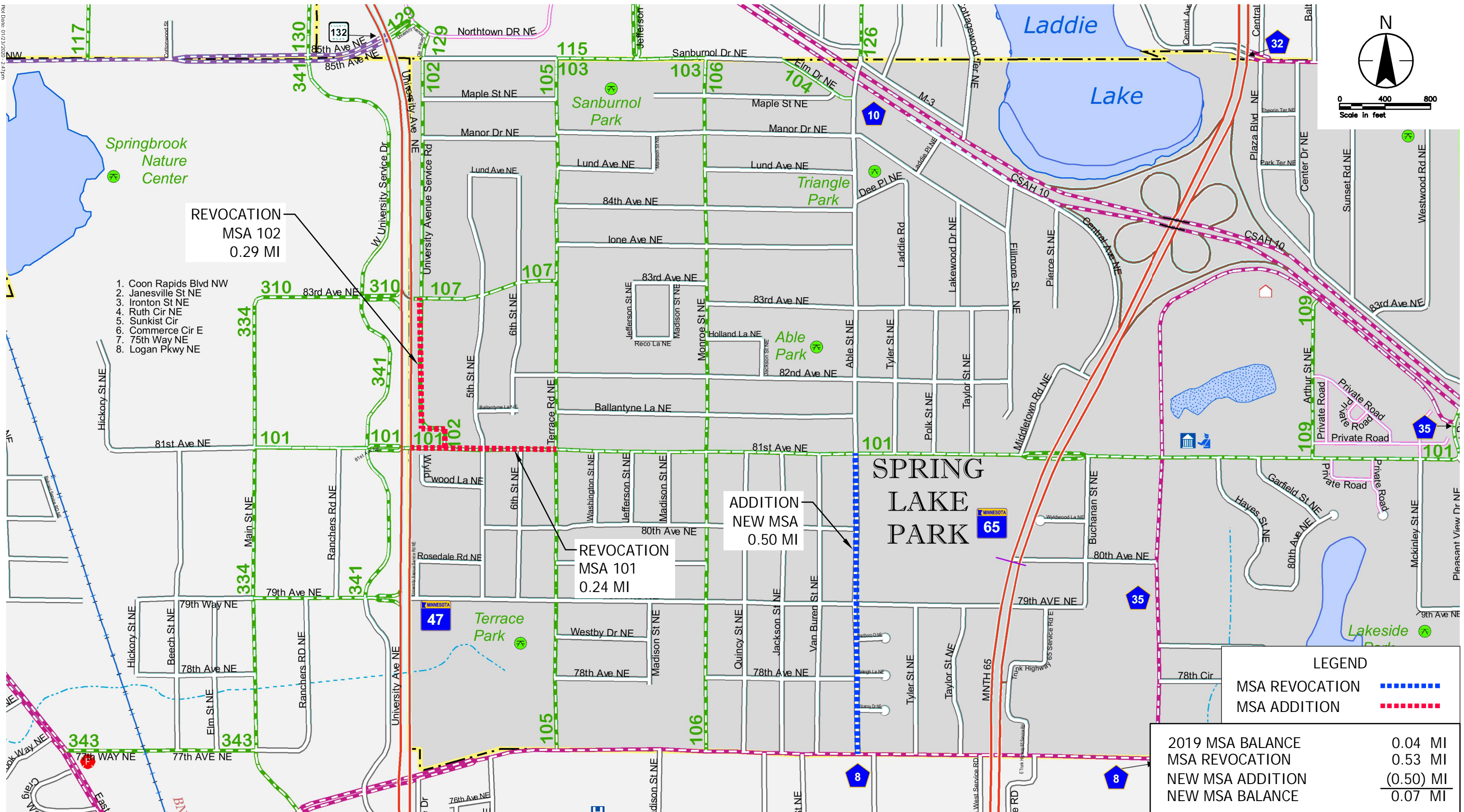

PROPOSED MSA SYSTEM REVISIONS - 2020

CITY OF SPRING LAKE PARK, MN  
 MUNICIPAL STATE AID SYSTEM

FIGURE 1



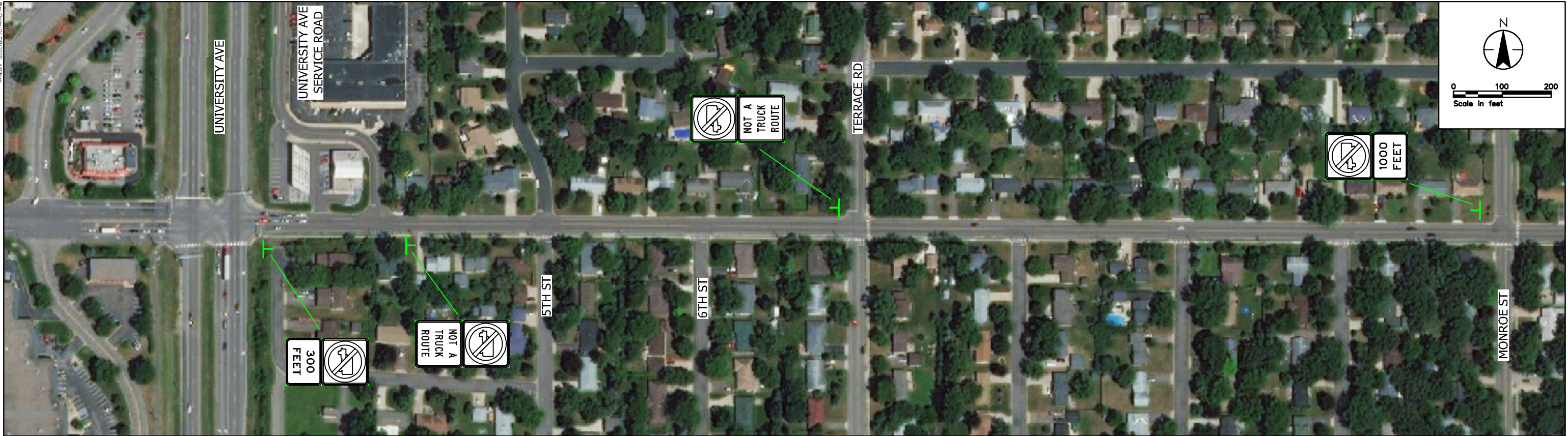

SIGNING LAYOUT

CITY OF SPRING LAKE PARK, MN  
81ST AVENUE - TRUCK SIGNING

FIGURE 1

Plot Date: 01/29/2020 - 4:03pm  
 Project Name: 193800050 - 81ST AVENUE TRUCK SIGNING  
 User: jacob.jacob@stantec.com  
 Xref: 193800050\_193800050\_81ST AVENUE TRUCK SIGNING.dwg

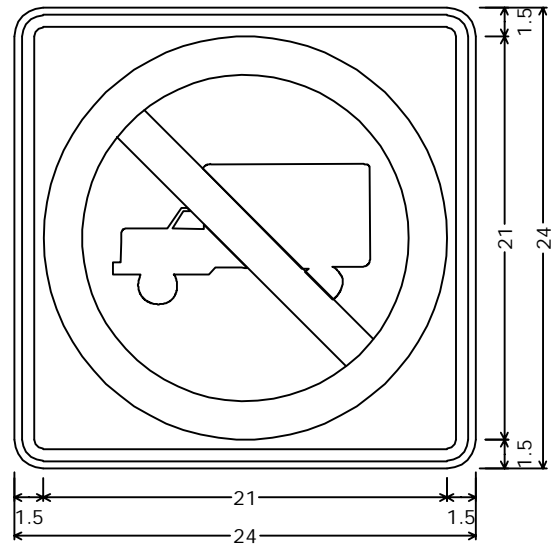

Identifier : R5-2\_24x24;  
 1.5" Radius, 0.6" Border, 0.4" Indent, Black on White;

TEXT OPTION

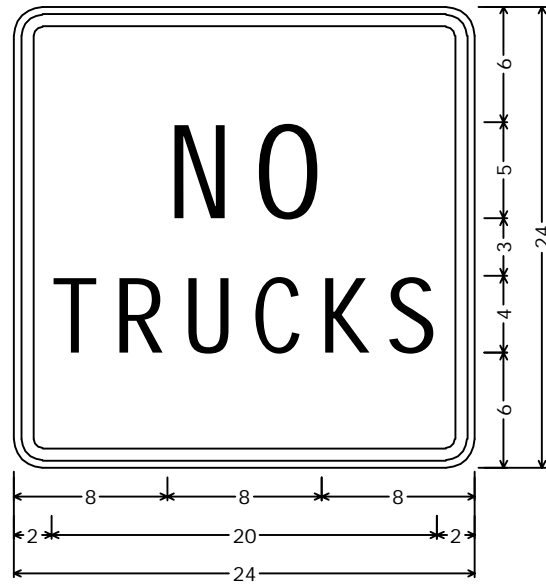

Identifier : 24x24;  
 1.5" Radius, 0.6" Border, 0.4" Indent, Black on White;  
 [NO] D; [TRUCKS] D;

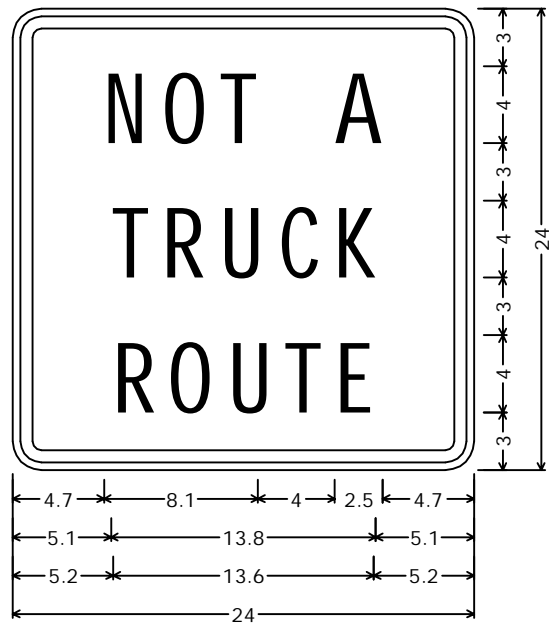

Identifier : 24x24;  
 1.5" Radius, 0.6" Border, 0.4" Indent, Black on White;  
 [NOT A] C; [TRUCK] C; [ROUTE] C;

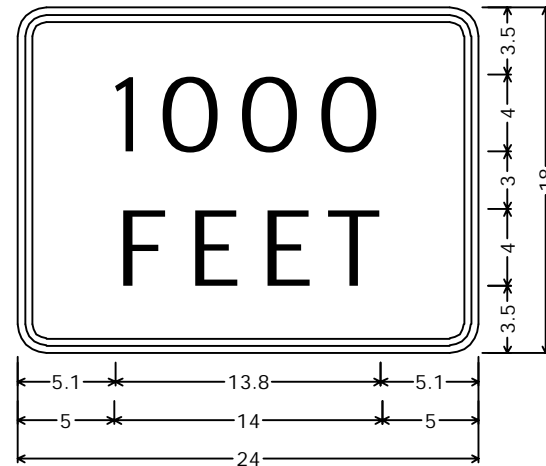

Identifier : W20-100P\_24x18;  
 1.5" Radius, 0.4" Border, 0.4" Indent, Black on White;  
 [1000] E; [FEET] E;

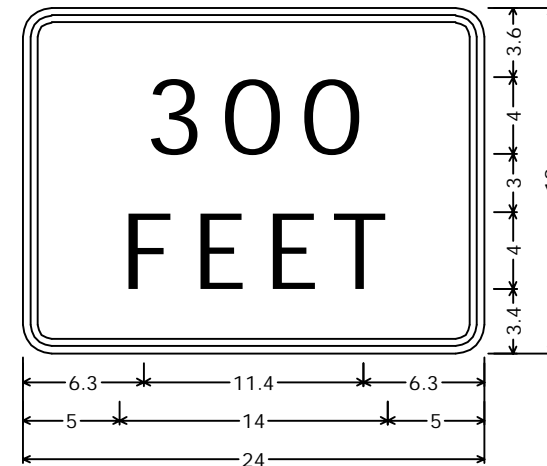

Identifier : W20-100P\_24x18;  
 1.5" Radius, 0.4" Border, 0.4" Indent, Black on White;  
 [300] E; [FEET] E;

SIGNING DETAILS



**ORDINANCE NO. XXX**

**AN ORDINANCE AMENDING CHAPTER 70 OF THE SPRING LAKE PARK CITY CODE RELATING TO TRAFFIC REGULATIONS**

The City Council of the City of Spring Lake Park, Minnesota, ordains as follows:

**Section 1.** §70.15 of the City Code is hereby amended to read as follows:

**§70.15 ~~SEASONAL ROAD RESTRICTIONS; COUNCIL AUTHORITY~~**

Whenever any street, alley, or public highway of the city, by reason of deterioration, rain, snow, or other climatic conditions, will be seriously damaged or destroyed unless the use, operation or movement of vehicles thereon is prohibited or the permissible weights thereon reduced, the City Council may by resolution prohibit the operation of vehicles thereon or impose restrictions as to the weight of vehicles to be operated thereon.

**Section 2.** Section §70.17 is hereby amended to read as follows:

**§70.17 NOTICE REQUIREMENT.**

Notice of prohibition or any restriction imposed under §70.15 hereof shall be made in the manner provided in M.S. §169.87 and by posting printed signs at each end of the restricted street and other places as the City Council shall deem advisable. Thereafter, it shall be unlawful for any person to use, operate or move any vehicle or combination of vehicles in and upon such street or public highway in the City contrary to the prohibitions set forth in such resolution and notice.

§70.17-§70.18 of the City Code are hereby renumbered to §70.18-§70.19.

**Section 3.** A new section, §70.17, is hereby adopted and reads as follows:

**§70.17 RESTRICTIONS.**

(A) It is hereby prohibited to operate trucks having a gross weight of more than 7,000 pounds on the following designated streets:

<u>Street</u>	<u>From</u>	<u>To</u>
<u>81<sup>st</sup> Avenue NE</u>	<u>University Ave Service Drive</u>	<u>Terrace Road</u>

(B) The above weight restrictions shall not apply to trucks making deliveries to, refuse trucks making collections at residences and businesses at the street(s) set forth in (A). The above weight restrictions set forth in (A) shall not apply to vehicles parked in residential districts in accordance to §153.066(B).

**Section 4.** This Ordinance shall take effect upon its passage and publication.

Passed by the City Council of the City of Spring Lake Park, Minnesota, this \_\_\_\_ day of \_\_\_\_\_ 2020.

\_\_\_\_\_  
Robert Nelson, Mayor

ATTEST:

\_\_\_\_\_  
Daniel R. Buchholtz, City Administrator/Clerk

## **SEASONAL ROAD RESTRICTIONS**

### **§ 70.15 SEASONAL ROAD RESTRICTIONS; COUNCIL AUTHORITY.**

Whenever any street, alley, or public highway of the city, by reason of deterioration, rain, snow, or other climatic conditions, will be seriously damaged or destroyed unless the use of vehicles thereon is prohibited or permissible weights thereon reduced, the City Council may by resolution prohibit the operation of vehicles thereon or impose restrictions as to the weight of vehicles to be operated thereon.

(1976 Code, § 50.01)

### **§ 70.16 NOTICE REQUIREMENT.**

Notice of prohibition or any restriction imposed under § 70.15 hereof shall be made by posting printed signs at each end of the restricted streets and other places as the City Council shall deem advisable.

(1976 Code, § 50.02)

### **§ 70.17 EXCEPTION; PERMISSION AND BOND REQUIRED.**

If any person shall desire to use an alley, street, or public highway of the city in a manner not authorized by reason of prohibitions or restrictions as are imposed under this subchapter, the City Council may, at its discretion, grant permission upon such conditions as it may prescribe, provided that the person shall first furnish to the city a bond or certified check with good and sufficient corporate surety thereon, guaranteeing to secure the payment of all costs of putting the street in as good condition as it was before prohibition or restriction, that bond or certified check and the amount thereof to be approved by the City Council.

(1976 Code, § 50.04)

### **§ 70.18 POLICE; RIGHT OF WEIGHT INQUIRY.**

Any police officer having reason to believe that the weight of a vehicle and load is unlawful is hereby authorized to require the driver to stop and submit to weighing of the same either by means of portable or stationary scales, and may require that the vehicle be driven to the nearest public scales. Any driver of a vehicle who fails or refuses to stop and submit the vehicle and load to weighing or who fails or refuses when directed by an officer, upon a weighing of the vehicle, to stop the vehicle and otherwise comply with the provisions of this subchapter shall be guilty of a misdemeanor.

(1976 Code, § 50.05) Penalty, see § 10.99

