

410,000 TO  
RUN H2O.



# PRICE QUOTATION

**Flowpoint Environmental Systems Inc.**  
191 University Blvd #467  
Denver, CO 80206-4613  
USA  
Phone: (877) 655-5585 Fax: (888) 655-5588

Quotation Number: 0319-S-0334  
Quotation Date: 2019-09-13  
**Expiration Date: 2019-11-13**  
Ship Via: INCLUDED  
FOB: FOB FACTORY  
Sales Person: JAY MORRISON / SCOTT YAKEL  
Terms: NET 30 DAYS

Email:

**To: CITY OF SAXMAN**  
2841 SOUTH TONGASS  
KETCHIKAN, AK 99901  
Attn:LORI RICHMOND

Line	Description	Quantity	Rate	Extended
1	POTABLE 3" WATER GENERAL INCLUDES: 48" X 76" X 88" TALL INSULATED ENCLOSURE, 3" REDUCED PRESSURE BACKFLOW PREVENTOR, 3" COMBINATION METER/VALVE, 3" 304SS PIPING, 1500 WATT ELECTRIC HEATER, INTERIOR AND EXTERIOR LED LIGHTING, AND CONVENIENCE RECEPTACLE.	1.00	-	-
2	ACCESS TERMINAL-THROUGH WALL 14" WIDE X 22" TALL X 16" DEEP NEMA 3R POWDERCOATED ALUMINUM INCLUDES ALLEN BRADLEY PLC AND FLOWPOINT STAINLESS STEEL KEYPAD THROUGH WALL MOUNT	1.00	-	-
3	OPTIONAL LOW VOLUME 3/4" FILL LINE	1.00	-	-
4	UBIQUITI RADIO KIT	1.00	-	-
5	FREIGHT	1.00	-	-
6	4 HOUR REMOTE STARTUP	1.00	-	-
<b>ALL PRICES ARE IN US DOLLARS</b>			<b>Quotation Total:</b>	<b>\$52,989.08</b>

**This is a quotation on the goods named, and is subject to the following conditions:**

- Taxes are not included.
- Installation is by others. Owner is responsible for all utility service connections including water service to and from station. Owner is responsible for offloading and / or storing the station until it is installed.
- All Shop Drawing Submittals and O&M Manuals are in Electronic Form (PDF) only. Hard copies, binding, and printing costs are by others
- Payment Terms: 20% on approval of shop drawings, 80% on delivery of goods.
- FOB Factory means the Owner is responsible for the station during freight (including, but not limited to any damage to unit during freight).
- Start Up services require: 1. Minimum 3 weeks notice to book 2. Completion of Start-up readiness checklist.

**In lieu of a formal purchase order commitment, to accept this quotation as your purchase order please sign below.**

\_\_\_\_\_  
Name

\_\_\_\_\_  
Position

\_\_\_\_\_  
Signature

\_\_\_\_\_  
Date

**Flowpoint Environmental Systems Inc.**

191 University Blvd #467  
 Denver, CO 80206-4613  
 USA

Phone: (877) 655-5585 Fax: (888) 655-5588

Email:

**PRICE QUOTATION**

Quotation Number: 0319-S-0334  
 Quotation Date: 2019-09-13  
**Expiration Date: 2019-11-13**  
 Ship Via: INCLUDED  
 FOB: FOB FACTORY  
 Sales Person: JAY MORRISON / SCOTT  
 YAKEL  
 Terms: NET 30 DAYS

**Flowpoint One Year Manufacturer's Warranty (Included):**

Flowpoint Environmental Systems (Manufacturer) warranty is as follows, and extends ONLY to the original purchaser of the equipment and is limited to the purchase price of each part. Manufacturer warrant products against defects in materials or workmanship as follows:

**LABOR:** For a period of 1 (one) year from the date of commission (start up), if Manufacturer determines that the equipment is defective subject to the limitations of this warranty, Manufacturer will replace or repair it at no charge for labor. Manufacturer warrants any such work done against defects in materials or workmanship for the remaining portion of the original warranty period.

**PARTS:** For a period of 1 (one) year from the date of commission (start up), Manufacturer will supply, at no charge, new or rebuilt replacement parts in exchange for parts that the Manufacturer determines are defective subject to the limitations of this warranty. Manufacturer warrants any such replacement parts against defects in materials or workmanship for the remaining portion of the original warranty period.

This warranty "does not cover" installation of the system or damages incurred during shipping.

This warranty "does not cover" consumer instruction, physical set up or adjustment of any electronic equipment, communication / signal reception problems, loss of use of the equipment, or unused programming charges due to equipment malfunction.

This warranty "does not cover" cosmetic damage, damage due to lightning, electrical surges, fire, flood, or other acts of God, accident, misuse, abuse, vandalism, repair or alteration by other than factory service, negligence, or improper or neglected maintenance.

This warranty "does not cover" equipment sold AS IS, REFURBISHED, or WITH ALL FAULTS, auction sales, equipment removal or reinstallation, nor equipment purchased, serviced, or operated by other dealers.



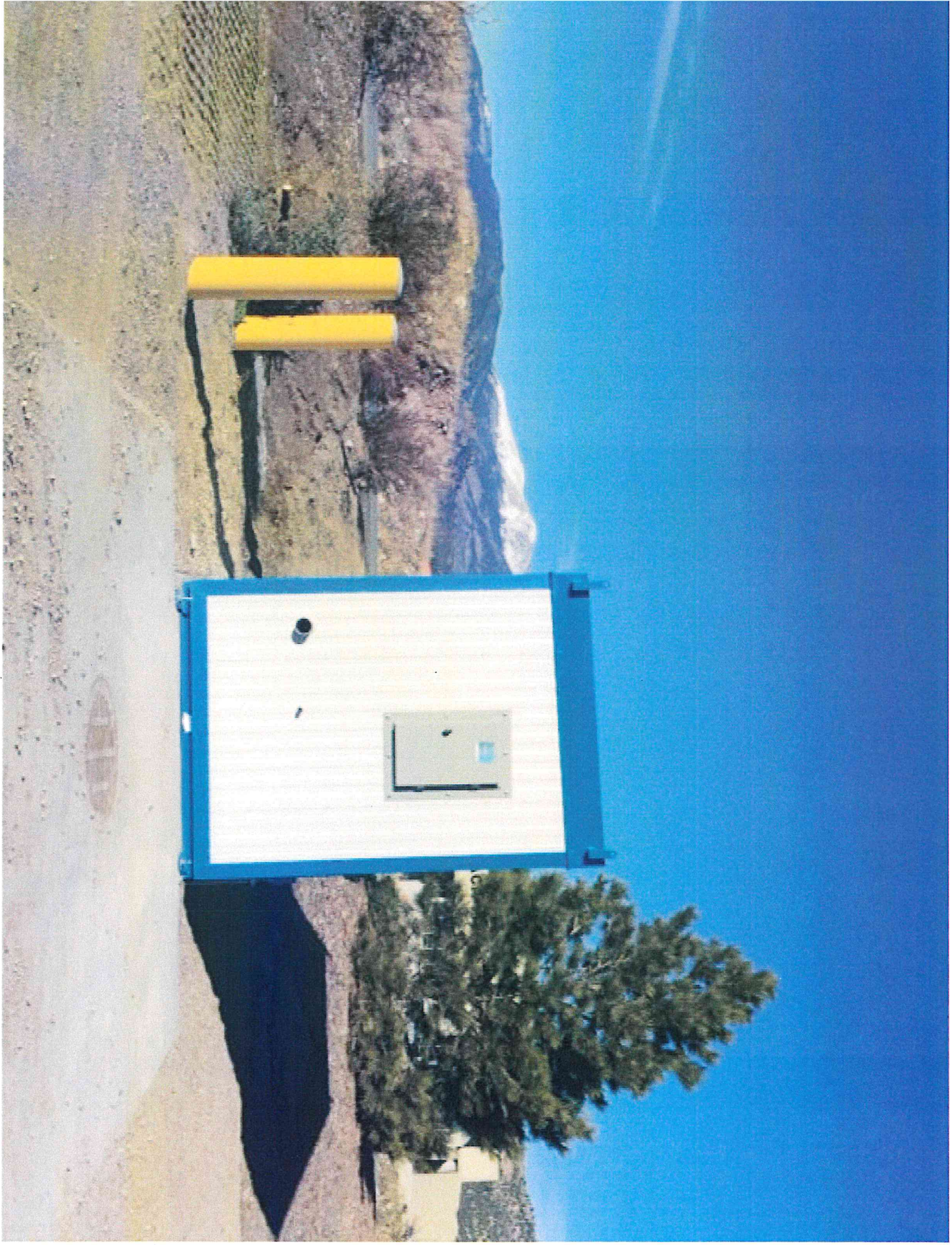



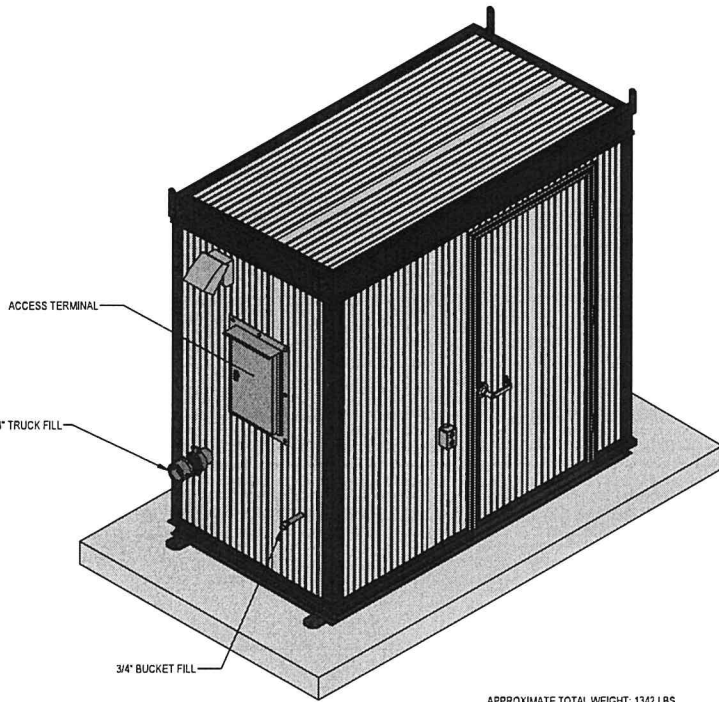

APPROXIMATE TOTAL WEIGHT: 1342 LBS

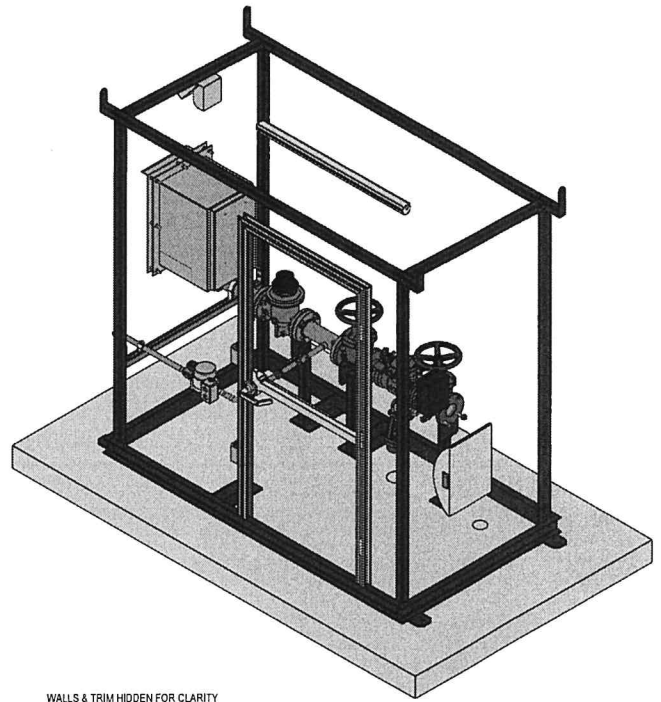

WALLS & TRIM HIDDEN FOR CLARITY  
VIEW ROTATED 90 DEGREES  
THIS VIEW IS CROPPED

NO	DR	CH	REVISION	APPD	DATE	SCALE: 1:20	UNITS: IN LBS	 <small>THIS DOCUMENT IS FOR THE SOLE USE OF FLOWPOINT THE DOCUMENT CONTAINS PROPRIETARY AND CONFIDENTIAL INFORMATION THAT SHALL NOT BE REPRODUCED IN ANY MANNER WITHOUT THE WRITTEN PERMISSION OF FLOWPOINT. INFORMATION ON THIS DOCUMENT IS TO BE CONSIDERED THE INTELLECTUAL PROPERTY OF FLOWPOINT IN ACCORDANCE WITH CANADIAN COPYRIGHT LAW.</small> <b>FLOWPOINT ENVIRONMENTAL SYSTEMS</b>	INSPECTION	DATE	SIGNATURE	<b>PROJECT</b> SAXMAN ALASKA WATER GENERAL BULK LOADING STATION ENCLOSURE ASSEMBLY	CLIENT		
A	AHK	JB	ISSUED FOR PROPCSAL		2018-08-13				BEFORE FAB					SAXMAN ALASKA	
									DURING FAB					TITLE GENERAL ARRANGEMENT	
									FINAL QC					DRAWING NO. 0319-S-0334-FULL ASSEMBLY-1	
													REV	A	

T:\Drawings - Flowpoint\Projects\Projects\2018-08-23\34 SAXMAN\Design\Sub\0319-S-0334-FULL ASSEMBLY

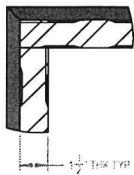

DETAIL A  
SCALE 1:5



SECTION A-A

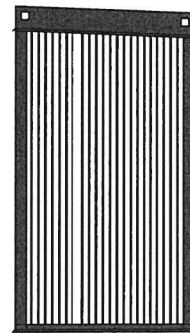
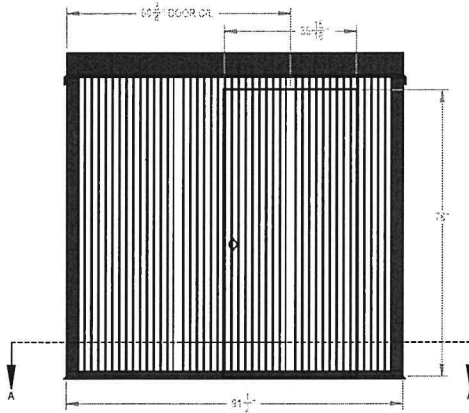
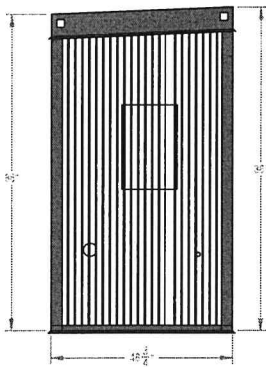

NO	DR	CH	REVISION	APPD	DATE	SCALE: 1:25	UNITS: IN, LBS		INSPECTION	DATE	SIGNATURE	PROJECT SAXMAN ALASKA WATER GENERAL BULK LOADING STATION ENCLOSURE ASSEMBLY	CLIENT SAXMAN ALASKA TITLE ENCLOSURE LAYOUT DRAWING NO. 0319-S-0334-FULL ASSEMBLY-2	REV A			
A	AHK	JB	ISSUED FOR PROPOSAL		2019-09-13				BEFORE FAB								
									DURING FAB								
									FINAL QC								

11/19/2019 - Flowpoint LP 0319-S-0334-FULL ASSEMBLY-2

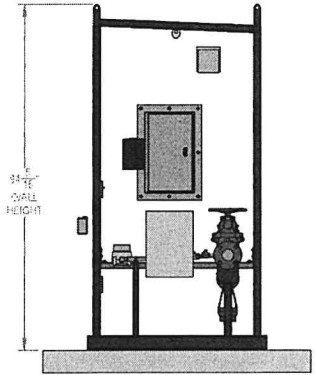
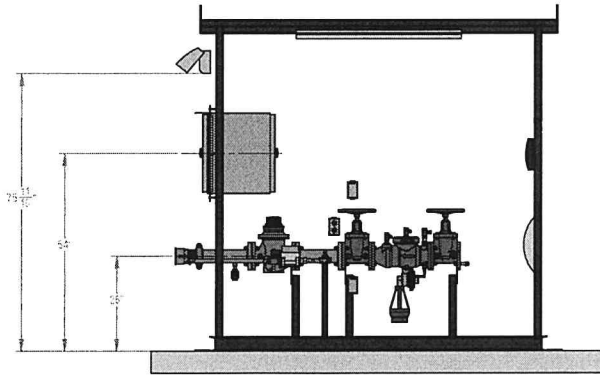
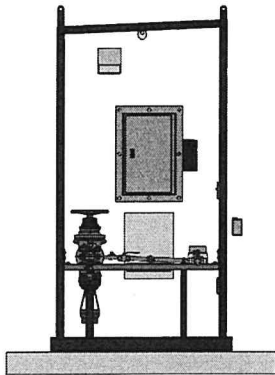
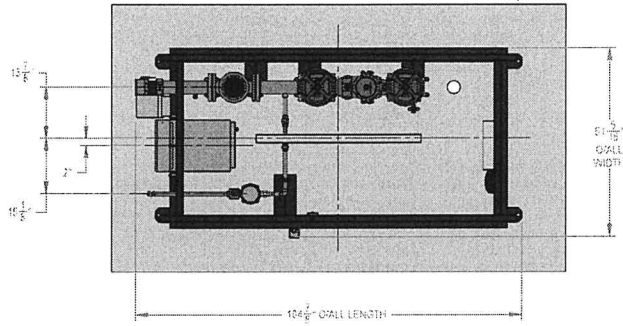

NO	DR	CH	REVISION	APPD	DATE	SCALE: 1:25	UNITS: IN, LBS		INSPECTION	DATE	SIGNATURE	PROJECT SAXMAN ALASKA WATER GENERAL BULK LOADING STATION ENCLOSURE ASSEMBLY	CLIENT	SAXMAN ALASKA TITLE EQUIPMENT LAYOUT DRAWING NO. 0319-S-0334-FULL ASSEMBLY-3	REV		
A	AHK	JB	ISSUED FOR PROPOSAL		2019-09-13				BEFORE FAB								
									DURING FAB								
									FINAL QC								

I:\Share\23 - Flowpoint\PD\dev\Project\Process\018-0334-SAXMAN\Drawings\0319-S-0334-FULL ASSEMBLY

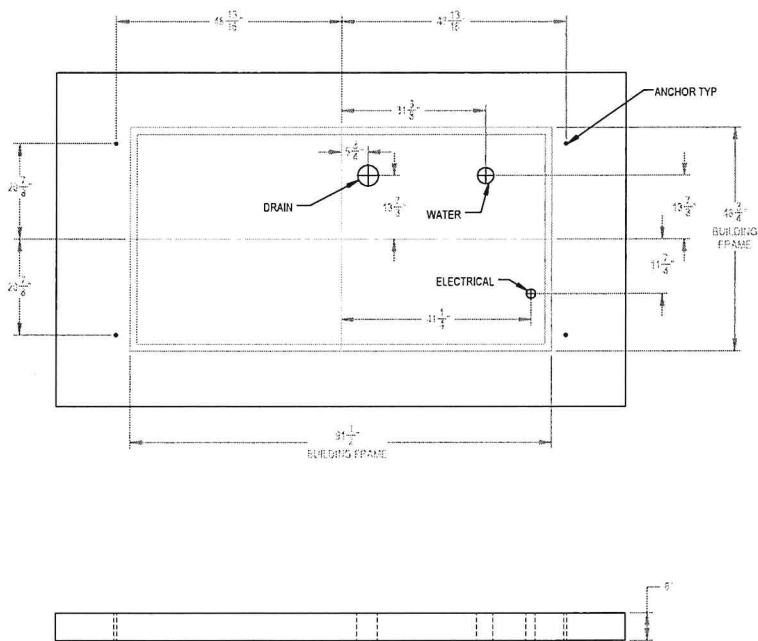

SLAB DESIGN AND ANCHORS BY OTHERS  
 CONTRACTOR TO CONFIRM PENETRATION LOCATIONS AND SIZES

NO	DR	CH	REVISION	APPD	DATE	SCALE: 1/20	UNITS: IN, LBS	 <p>THIS DOCUMENT IS FOR THE SOLE USE OF FLOWPOINT. THE DOCUMENT CONTAINS FLOWPOINT AND CONFIDENTIAL INFORMATION THAT SHALL NOT BE REPRODUCED, COPIED, OR TRANSMITTED IN ANY FORM OR BY ANY MEANS WITHOUT THE EXPRESSED WRITTEN PERMISSION OF FLOWPOINT. BY SIGNATURE OF THIS DOCUMENT IS TO BE CONSIDERED THE ACCEPTANCE OF FLOWPOINT'S POLICY OF ACCORDANCE WITH CANADIAN COPYRIGHT LAW.</p>	INSPECTION	DATE	SIGNATURE	PROJECT SAXMAN ALASKA WATER GENERAL BULK LOADING STATION ENCLOSURE ASSEMBLY	CLIENT		
A	AHK	JB	ISSUED FOR PROPOSAL		2019-09-13				BEFORE FAB					SAXMAN ALASKA	
									DURING FAB					TITLE	
									FINAL QC					DRAWING NO. 0319-S-0334-FULL ASSEMBLY-4	
												REV	A		

119-0-021 - Flowpoint LP Sales Presentations\0319-S-0334-SAXMAN Alaska\0319-S-0334-FULL ASSEMBLY



# QUOTE

OL ▽

## Flowpoint Environmental Systems

191 University Blvd #467  
 Denver, CO 80206  
 Phone: 877-655-5585  
 Fax: 888-655-5588  
 sales@flowpointsystems.com

QUOTE # 2016-280  
 DATE: 8/23/2016  
 EXPIRATION DATE 10/24/2016

TO Maxwell Mercer  
 Saxman

WILL EMAIL NEW COST

AK

(907) 617-2994

SALESPERSON	LOCATION	SHIPPING METHOD	SHIPPING TERMS	DELIVERY DATE	PAYMENT TERMS
Jay Morrison		INCLUDED	FOB FACTORY		

LINE ITEM	QUANTITY	DESCRIPTION	UNIT PRICE	LINE TOTAL
1	1.0000	<b>WATER SYSTEM-US</b> <b>MANUFACTURING-401010</b>  1.00 WG3RPCOMXXXEW1MXXXXXXXXX WATER GENERAL - 3" INCLUDES:REDUCED PRESSURE PRINCIPLE ASSEMBLY BACKFLOW PREVENTOR,COMBINATION METER/VALVE,ETHERNET COMMUNICATION,1500W HEATER,INTERIOR LED LIGHT & ONE ACCESS POINT. ONE ELECTRONIC SHOP DRAWING SUBMITTAL. ONE ELECTRONIC O&M MANUAL. < 12 MONTHS FREE ONLINE BILLING SOFTWARE (ALWAYS FREE) TECHNICAL SUPPORT > 795/YR. NOTE: RECOMMENDED SYSTEM PRESSURE IS 40-80 PSI AND MAXIMUM FLOW RATE (BASED ON PIPE SIZING) IS 350GPM (3"). 1.00 OLA LOW VOLUME FILL PACKAGE 3/4" PIPING 1.00 DIGI RADIO (INTERNET) 900mHz Wireless Bridge 1.00 FREIGHT-US FREIGHT-442000 1.00 STARTUP-REMOTE-US 4 HOUR REMOTE STARTUP-452000		
TOTAL				44,718.48



Quotation prepared by: Jay Morrison

This is a quotation on the goods named, and is subject to the following conditions:

Taxes are not included. All prices are in US dollars unless otherwise noted. Installation is by others. Owner is responsible for all utility service connections including water service to and from station. Owner is responsible for offloading and / or storing the station until it is installed. Payment Terms: 20% on approval of shop drawings, 80% on delivery of goods.

FOB Factory means the Owner is responsible for the station during freight (including, but not limited to any damage to unit during freight). Start Up services require: 1. Minimum 3 weeks notice to book 2. Completion of Start-up readiness checklist.

To accept this quotation, sign here and return: SIGN: \_\_\_\_\_ PRINT NAME: \_\_\_\_\_

POSITION: \_\_\_\_\_ DATE: \_\_\_\_\_

### Flowpoint One Year Manufacturer's Warranty (Included):

Flowpoint Environmental Systems (Manufacturer) warranty is as follows, and extends ONLY to the original purchaser of the equipment and is limited to the purchase price of each part. Manufacturer warrant products against defects in materials or workmanship as follows:

**LABOR:** For a period of 1 (one) year from the date of commission (start up), if Manufacturer determines that the equipment is defective subject to the limitations of this warranty, Manufacturer will replace or repair it at no charge for labor. Manufacturer warrants any such work done against defects in materials or workmanship for the remaining portion of the original warranty period.

**PARTS:** For a period of 1 (one) year from the date of commission (start up), Manufacturer will supply, at no charge, new or rebuilt replacement parts in exchange for parts that the Manufacturer determines are defective subject to the limitations of this warranty. Manufacturer warrants any such replacement parts against defects in materials or workmanship for the remaining portion of the original warranty period.

This warranty "does not cover" installation of the system or damages incurred during shipping.

This warranty "does not cover" consumer instruction, physical set up or adjustment of any electronic equipment, communication / signal reception problems, loss of use of the equipment, or unused programming charges due to equipment malfunction.

This warranty "does not cover" cosmetic damage, damage due to lightning, electrical surges, fire, flood, or other acts of God, accident, misuse, abuse, vandalism, repair or alteration by other than factory service, negligence, or improper or neglected maintenance.

This warranty "does not cover" equipment sold AS IS, REFURBISHED, or WITH ALL FAULTS, auction sales, equipment removal or reinstallation, nor equipment purchased, serviced, or operated by other dealers.