STRUCTURAL ENGINEERING CALCULATIONS

PROJECT: 110 x 291.5 x 48 Zekelman Industries

PROJECT LOCATION: 1600 Ritchie Court
Rochelle, IL 61068

PROJECT NUMBER: Big Top 226-093

DATE: 4/14/2026

A. GENERAL REQUIREMENT:

1. Furnish all labor, materials, and equipment necessary to complete the work shown or inferred by these drawings.
2. Where construction details are not shown or noted for any part of the work, such details shall be the same as for similar work shown on the drawings.
3. Notes and details on the drawings take precedence over the general notes and typical details in case of conflict.
4. Locate and protect underground or concealed conduit, plumbing or other utilities where new work is being performed.
5. The contract drawings and specifications represent the finished structure and do not indicate methods, procedures or sequence of construction. The contractor shall take necessary precautions to maintain and insure the integrity of the new and any existing structures during construction. The design stresses shall not be exceeded during construction based on the age of each element. Neither the owner nor Architect/Engineer will enforce safety measure regulations. Installation Contractor shall design, construct and maintain all safety devices, including shoring and bracing for the new and any existing structures and shall be solely responsible for conforming to all local, state and federal safety and health standards, laws and regulations.
6. Obtain prior written approval for any changes to the drawings.
7. The contractor shall review and compare the structural drawings with all other Construction Documents, such as Architectural, Mechanical and Electrical drawings, specifications, etc. Do not scale drawings. The contractor shall verify dimensions, elevations and all information. Report, in writing, any inconsistencies, errors, or omissions to the Architect/Engineer of record before proceeding with the work.
8. All existing constructions are shown schematic only. Installation Contractor is responsible to verify actual conditions and allow for them in his bid. Notify the Architect/Engineer, in writing, in case of any discrepancy between actual conditions and what is shown on the structural drawings before proceeding with the work.
9. See Architectural, Mechanical, Electrical and other drawings for embedded items.
10. All communication shall be in writing. No verbal communications, decisions, instructions or approvals shall be valid.
11. Adequate drainage path must be provided to drain water away from the perimeter of the building.

B. CODE AND LOADS:

1. All material and construction work for this project shall conform to the 2021 International Building Code (IBC 2021) along with Amendments by the Local Authority Having Jurisdiction. The International Building Code Parameters are:
 - a. Roof Dead Load = 2 PSF
 - b. Ground Snow Load = 30 PSF
 - c. Roof Snow Load = 25.2 PSF (FLAT)
 - d. Roof Live Load = 5 PSF
 - e. Seismic Occupancy Category = II
 - f. R, Response Modification Coefficient = 3.0
 - g. Ultimate Wind Speed, V3g = 110 mph, Exposure = C, Category II
 - h. Collateral Load = 3 PSF

C. HOT-ROLLED STEEL:

1. Tube Frames shall be manufactured from A500 in-line galvanized steel with the following properties:
 - a. Yield strength: 50,000 psi (rectangular); 55,000 psi (round)
 - b. Tensile Strength: 55,000 psi (rectangular); 60,000 psi (round)
 - c. The in-line galvanized steel tube meet the ASTM A-1057A & ASTM A1057M - 08 Standard Specification for in-line galvanized coating.

See pages 33-36, 295 for un-factored reactions.

D. FOUNDATION DESIGN:

1. Concrete pad/foundation design/check to support the truss reactions/loads was not included in the scope of services.
2. Any foundations shown on the drawings, are approximate and need to be verified/checked based on the local site conditions and local soil properties by a licensed Engineer hired by the Contractor/Builder or Owner of this shelter.
3. For soil anchor applications, see page S-0.1 for additional requirements.

ALL INFORMATION IS PROPERTY OF BIG TOP MANUFACTURING LLC  BIG TOP MANUFACTURING LLC 3255 US HWY 19 NORTH PERRY, FL 32347 PH: (850) 584 - 7786	CUSTOMER: ZEKELMAN INDUSTRIES	SHEET DESCRIPTION: GENERAL NOTES		
	STRUCTURE SIZE: 110 X 291.5 X 48	LOCATION: ROCHELLE, IL		
	TRUSS STYLE: 48" FOUR-CHORD	DRAWN BY: G. ANDREWS	SALES REPRESENTATIVE: THOMAS H.	
	PROJECT NO: 226-093	DATE: 04/14/2026	ISSUE: REV 0	SHEET NO: S-0

NOT FOR
CONSTRUCTION

STAMP ONLY

D. FOUNDATION DESIGN CONTINUED:

4. For soil anchor applications, as an alternative to item 2 on sheet S-0, the following approximate method could be used.
 - a. Number of soil anchors shown on the plans assumed that the soil anchor's ultimate capacity is 1200 lbs minimum, which shall be verified by site test results.
 - b. Pull out strength varies based on the local soil type and shall be verified by local soil tests at the site.
 - c. The tables below should be used as a guide only and subject to results of anchor pull test at the site.
 - d. Perform soil anchor tests to verify the above value for the soil type. A minimum of four tests shall be conducted to verify the assumed capacity above.
 - e. Use an approved method to obtain the values for the site:
 - (i) Dynamometer to obtain uplift by pulling out the anchors with a forklift
 - (ii) Hydraulic Pump
 - f. Pull out strength shall be measured at a maximum deflection/letup of 1/2 inch.
 - g. The tests shall be performed by a third party approved testing agency. In absence of a third party approved testing agency, the tests shall be performed in the presence of at least two of the following representatives and the results thereafter shall be signed by them upon completion of the tests.
 - (i) Big Top Manufacturing representative
 - (ii) Customer representative
 - (iii) Installation representative
 - h. If the test results are less than the above value, do not install the anchors and contact the Engineer of Record immediately, both by telephone and in writing.
 - i. If the test results are equal to or more than the above value, install the soil anchors as shown on the plans.
 - j. Results of the tests shall be submitted to both the Engineer of Record and to the Engineering Manager of Big Top Manufacturing LLC
 - k. The Owner and/or the Installation Contractor shall assume all responsibilities for the accuracy of the test results when using this method.

Soil Anchor Installation Guideline

Soil Type	Anchor Capacity (lbs)
Soft/Medium Sandy	600
Medium/Sandy Grass Top	1000
Medium/Sandy Soil Gray	1200
Medium/Sandy with Asphalt Top	1800
Medium Soil with Limerock and Asphalt	2000
Caliche	2500
Medium Dense Soil - Dry	3000
Medium Dense Soil with Asphalt Top	3500
Hard Clay	5500
Hard Clay with Aspalt Top	6000

Time to Set Anchor (min)	Pull Out Strength (lbs)
<1	0
1-3	0
4-6	600-1100
7-9	1100-1800
10-15	1800-2500
>15	2500-3500

Time to Set Anchor (min)	Pull Out Strength (lbs)
<1	0
1-3	600-1100
4-6	1100-1800
7-9	1800-2500
10-15	2500-3500
>15	>3500

Soil Anchor Capacity Based on Time to Set Anchor w/ 60lb Breaker

② Scale: N.T.S.

Soil Anchor Capacity Based on Time to Set Anchor w/ 90lb Breaker

③ Scale: N.T.S.

Soil Anchor Capacity Based on Soil Type

① Scale: N.T.S.

NOT FOR CONSTRUCTION

 BIG TOP MANUFACTURING LLC 3255 US HWY 19 NORTH PERRY, FL 32347 PH: (850) 584 - 7786	ALL INFORMATION IS PROPERTY OF BIG TOP MANUFACTURING LLC	CUSTOMER: ZEKELMAN INDUSTRIES	SHEET DESCRIPTION: SOIL ANCHOR NOTES	
		STRUCTURE SIZE: 110 X 291.5 X 48	LOCATION: ROCHELLE, IL	
		TRUSS STYLE: 48" FOUR-CHORD	DRAWN BY: G. ANDREWS	SALES REPRESENTATIVE: THOMAS H.
		PROJECT NO: 226-093	DATE: 04/14/2026	ISSUE: REV 0

STAMP ONLY

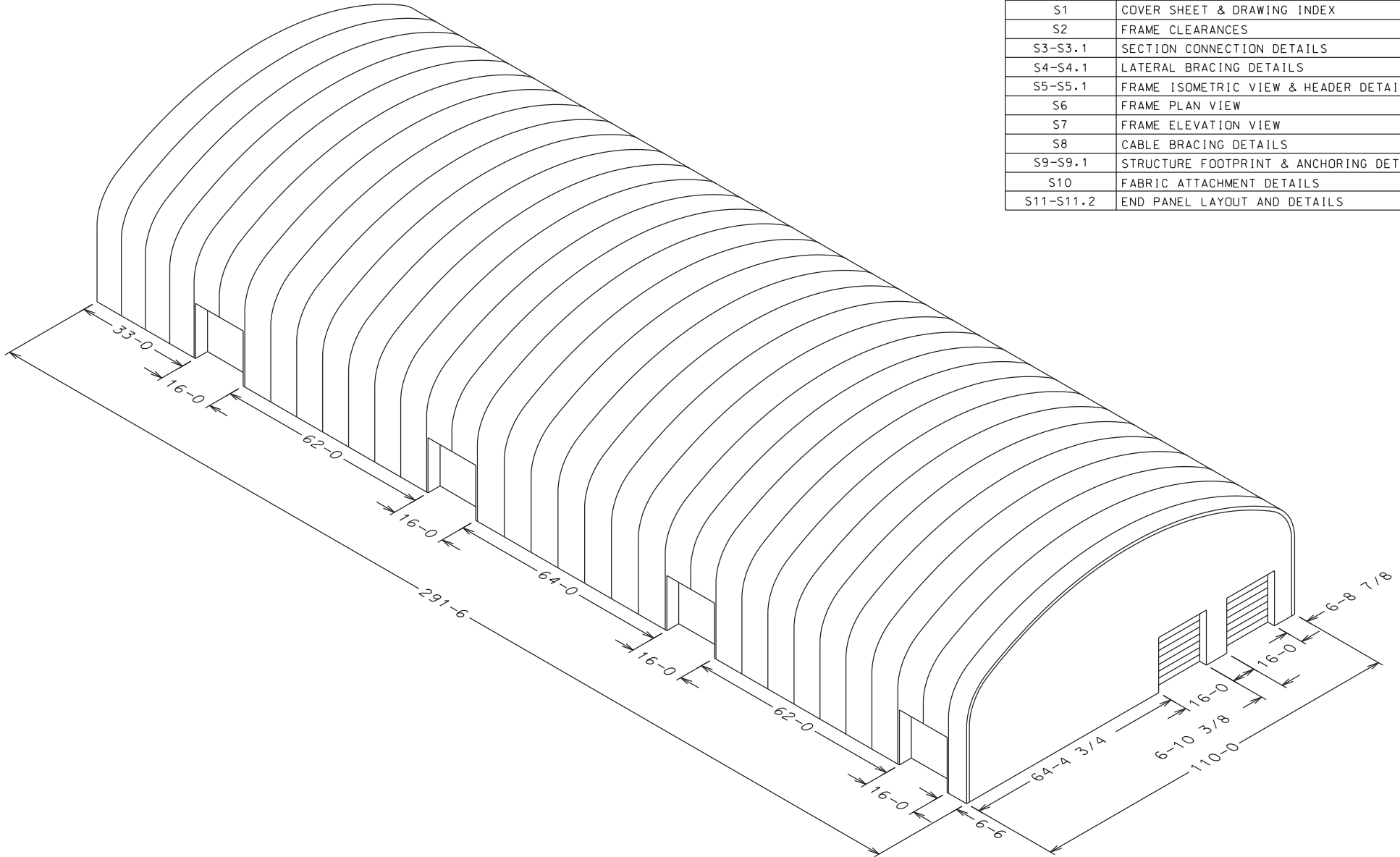

INDEX	
DRAWING NO.	DESCRIPTION
S1	COVER SHEET & DRAWING INDEX
S2	FRAME CLEARANCES
S3-S3.1	SECTION CONNECTION DETAILS
S4-S4.1	LATERAL BRACING DETAILS
S5-S5.1	FRAME ISOMETRIC VIEW & HEADER DETAILS
S6	FRAME PLAN VIEW
S7	FRAME ELEVATION VIEW
S8	CABLE BRACING DETAILS
S9-S9.1	STRUCTURE FOOTPRINT & ANCHORING DETAILS
S10	FABRIC ATTACHMENT DETAILS
S11-S11.2	END PANEL LAYOUT AND DETAILS

**NOT FOR
CONSTRUCTION**

STAMP ONLY

ALL INFORMATION IS PROPERTY
OF BIG TOP MANUFACTURING LLC



BIG TOP
BIG TOP MANUFACTURING LLC
3255 US HWY 19 NORTH
PERRY, FL 32347
PH: (850) 584 - 7786

CUSTOMER: ZEKELMAN INDUSTRIES
STRUCTURE SIZE: 110 X 291.5 X 48
TRUSS STYLE: 48" FOUR-CHORD
PROJECT NO: 226-093

SHEET DESCRIPTION: COVER SHEET & DRAWING INDEX	
LOCATION: ROCHELLE, IL	
DRAWN BY: G. ANDREWS	SALES REPRESENTATIVE: THOMAS H.
DATE: 04/14/2026	ISSUE: REV 0
	SHEET NO: S-1

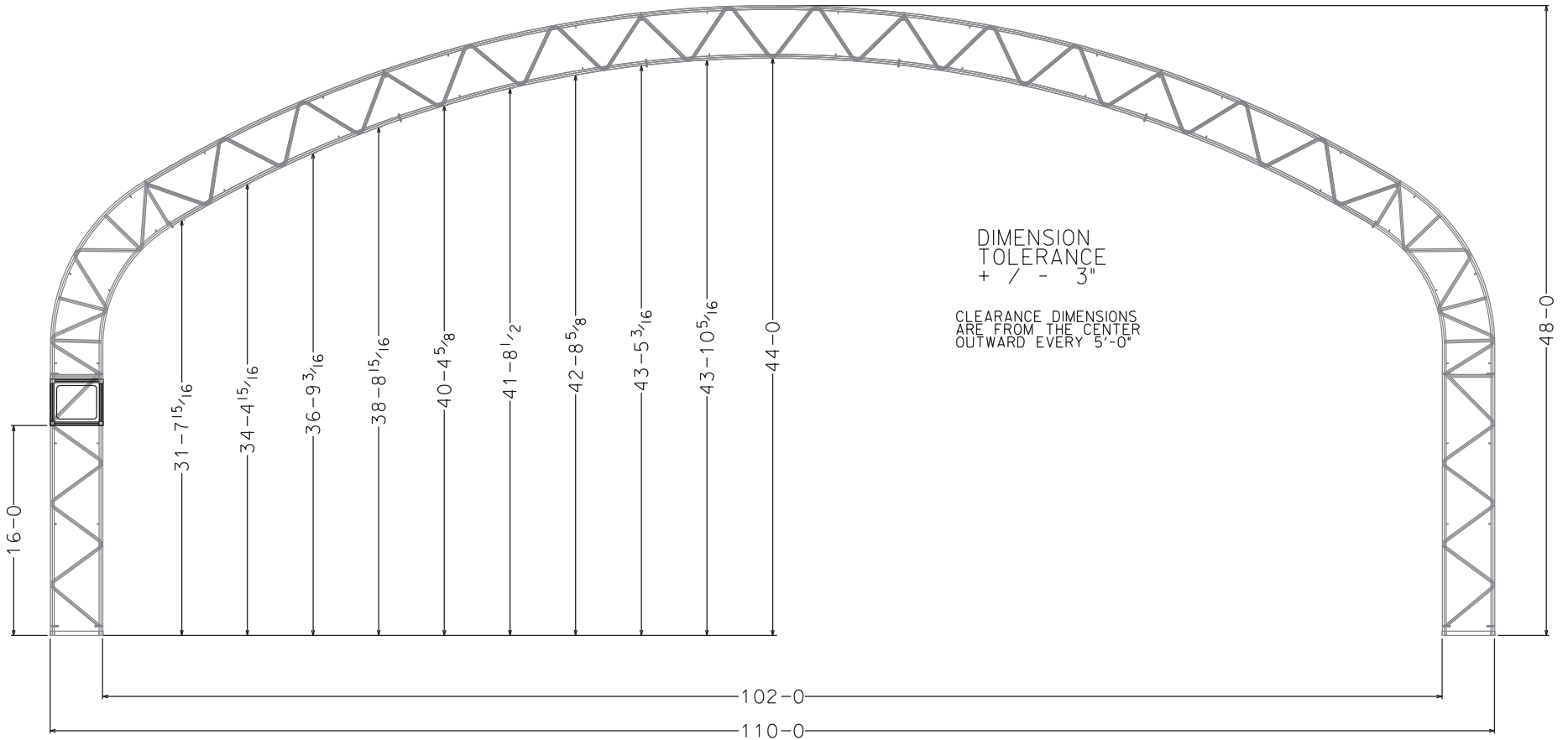

DIMENSION
TOLERANCE
+ / - 3"

CLEARANCE DIMENSIONS
ARE FROM THE CENTER
OUTWARD EVERY 5'-0"

NOT FOR
CONSTRUCTION

ALL INFORMATION IS PROPERTY
OF BIG TOP MANUFACTURING LLC



BIG TOP MANUFACTURING LLC
3255 US HWY 19 NORTH
PERRY, FL 32347
PH: (850) 584 - 7786

CUSTOMER: ZEKELMAN INDUSTRIES
STRUCTURE SIZE: 110 X 291.5 X 48
TRUSS STYLE: 48" FOUR-CHORD
PROJECT NO: 226-093

SHEET DESCRIPTION: FRAME CLEARANCES	
LOCATION: ROCHELLE, IL	
DRAWN BY: G. ANDREWS	SALES REPRESENTATIVE: THOMAS H.
DATE: 04/14/2026	ISSUE: REV 0
SHEET NO: S-2	

STAMP ONLY

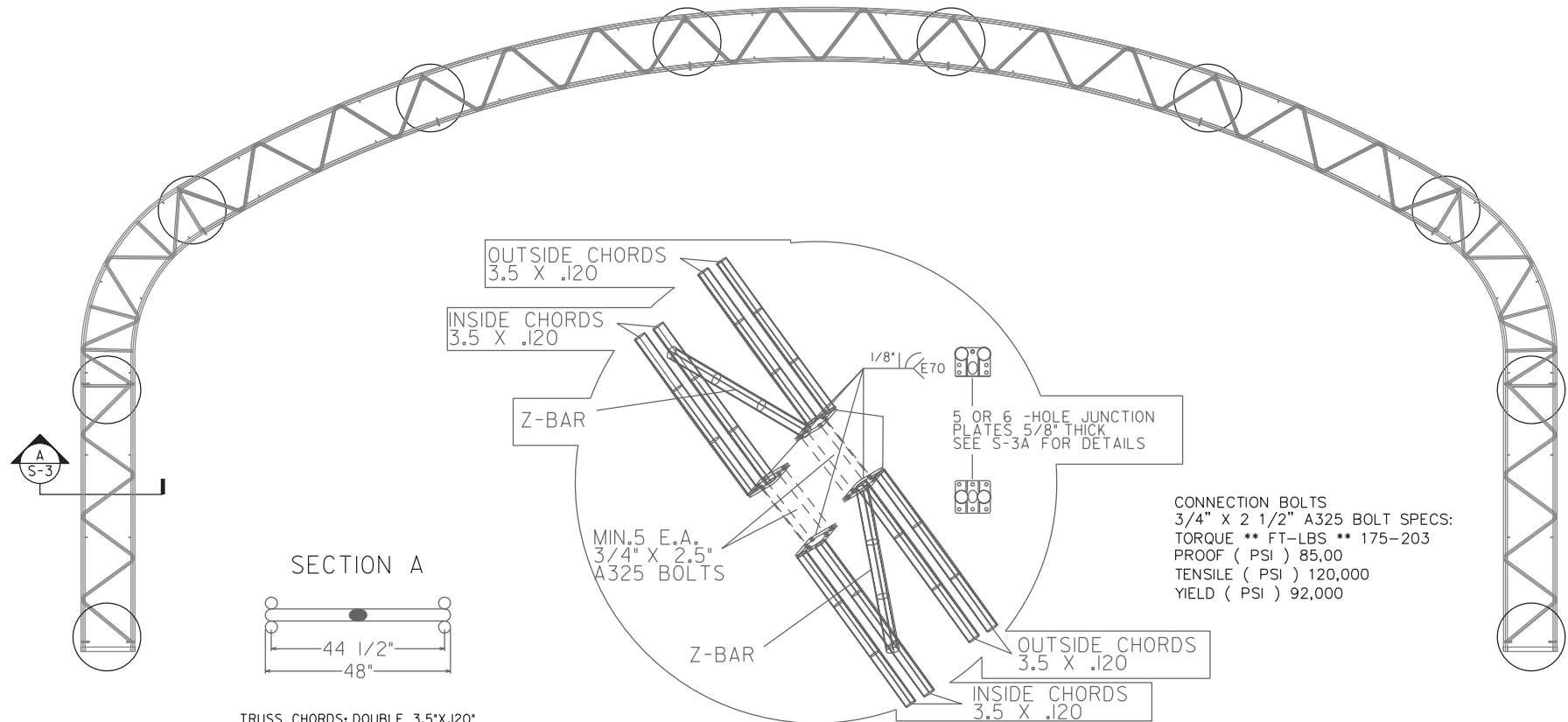

CONNECTION BOLTS
 3/4" X 2 1/2" A325 BOLT SPECS:
 TORQUE ** FT-LBS ** 175-203
 PROOF (PSI) 85,00
 TENSILE (PSI) 120,000
 YIELD (PSI) 92,000

SECTION A

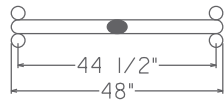

TRUSS CHORDS: DOUBLE 3.5" X .120"
 YIELD: 55,000 PSI (ROUND)
 TENSILE: 60,000 PSI (ROUND)

Z-BAR: 2.375" X 0.120"
 YIELD: 55,000 PSI (ROUND)
 TENSILE: 60,000 PSI (ROUND)

NOT FOR
 CONSTRUCTION

ALL INFORMATION IS PROPERTY
 OF BIG TOP MANUFACTURING LLC

BIG TOP MANUFACTURING LLC
 3255 US HWY 19 NORTH
 PERRY, FL 32347
 PH: (850) 584 - 7786

CUSTOMER: ZEKELMAN INDUSTRIES
STRUCTURE SIZE: 110 X 291.5 X 48
TRUSS STYLE: 48" FOUR-CHORD
PROJECT NO: 226-093

SHEET DESCRIPTION: SECTION CONNECTION DETAILS	
LOCATION: ROCHELLE, IL	
DRAWN BY: G. ANDREWS	SALES REPRESENTATIVE: THOMAS H.
DATE: 04/14/2026	ISSUE: REV 0
	SHEET NO: S-3

STAMP ONLY

NOTE: SEE S5 FOR PURLIN LOCATIONS.

LEGEND	
□	RIDGE POLE
△	PURLIN
○	X-BRACE

SEE S-4.1 FOR DETAILS

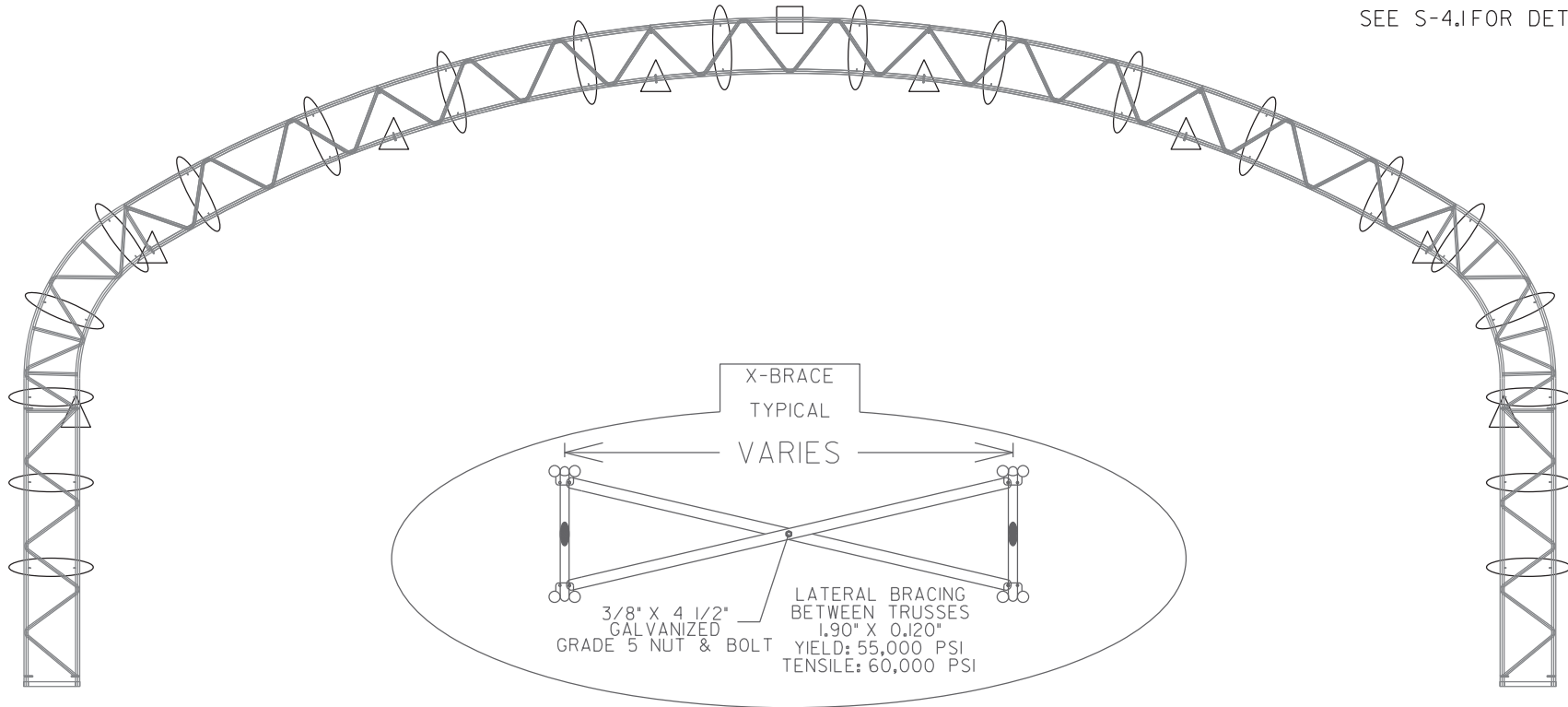

NOT FOR
CONSTRUCTION

ALL INFORMATION IS PROPERTY
OF BIG TOP MANUFACTURING LLC

BIG TOP MANUFACTURING LLC
3255 US HWY 19 NORTH
PERRY, FL 32347
PH: (850) 584 - 7786

CUSTOMER: ZEKELMAN INDUSTRIES
STRUCTURE SIZE: 110 X 291.5 X 48
TRUSS STYLE: 48" FOUR-CHORD
PROJECT NO: 226-093

SHEET DESCRIPTION: LATERAL BRACING LOCATIONS	
LOCATION: ROCHELLE, IL	
DRAWN BY: G. ANDREWS	SALES REPRESENTATIVE: THOMAS H.
DATE: 04/14/2026	ISSUE: REV 0
SHEET NO: S-4	

STAMP ONLY

NOTE:
5/8" PLATE THICKNESS
A572 GR. 50 STEEL

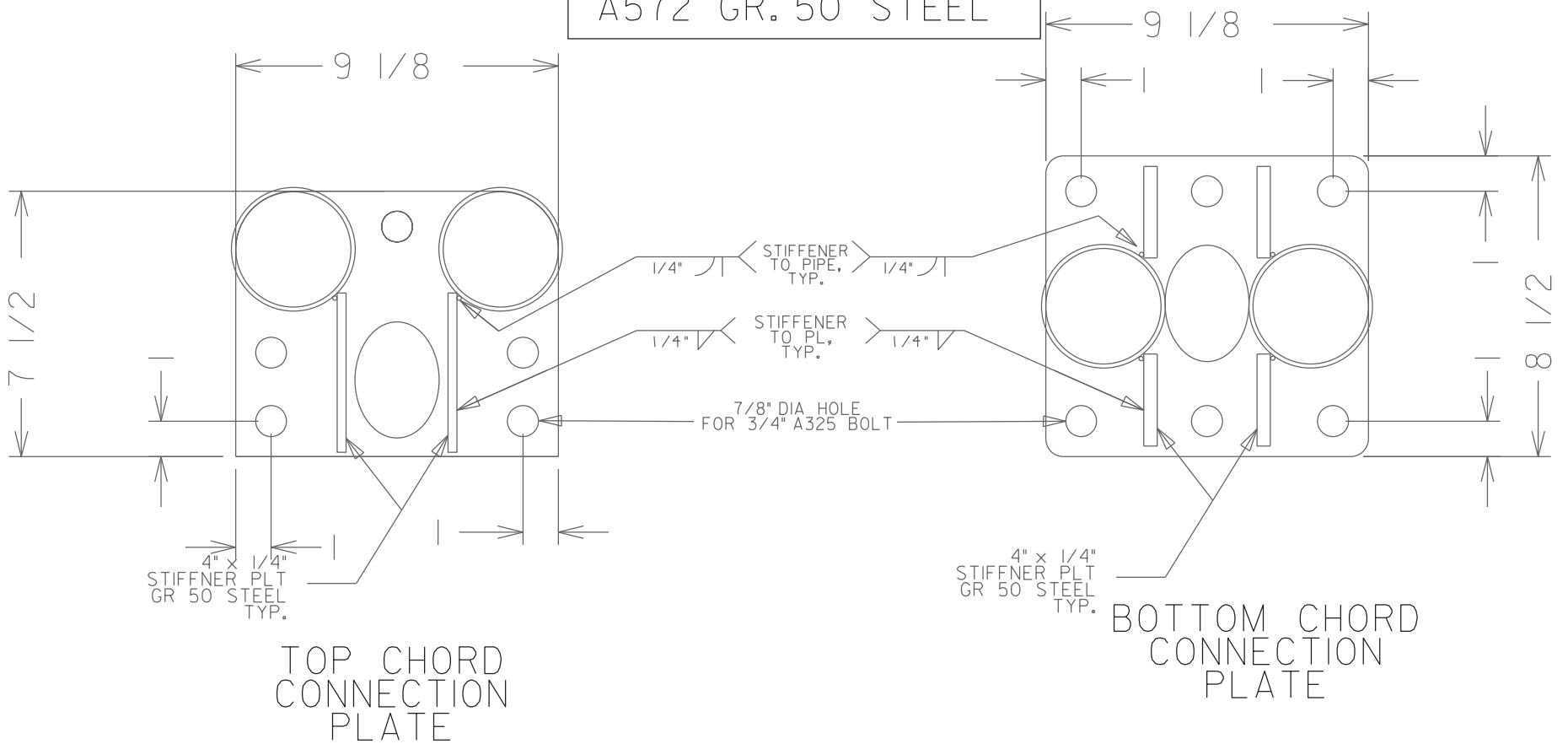

NOT FOR
CONSTRUCTION

ALL INFORMATION IS PROPERTY
OF BIG TOP MANUFACTURING LLC



BIG TOP MANUFACTURING LLC
3255 US HWY 19 NORTH
PERRY, FL 32347
PH: (850) 584 - 7786

CUSTOMER: ZEKELMAN INDUSTRIES
STRUCTURE SIZE: 110 X 291.5 X 48
TRUSS STYLE: 48" FOUR-CHORD
PROJECT NO: 226-093

SHEET DESCRIPTION: SECTION CONNECTION DETAILS	
LOCATION: ROCHELLE, IL	
DRAWN BY: G. ANDREWS	SALES REPRESENTATIVE: THOMAS H.
DATE: 04/14/2026	ISSUE: REV 0
SHEET NO: S-3.1	

STAMP ONLY

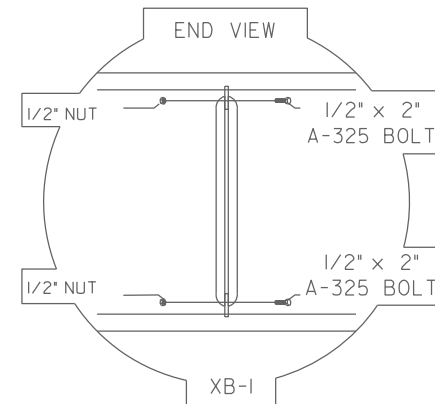
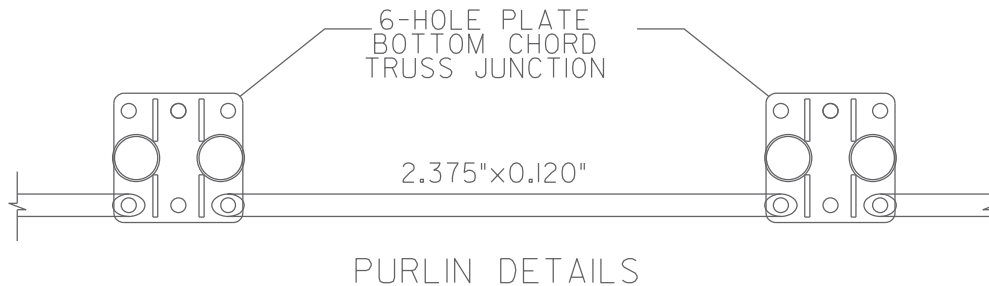
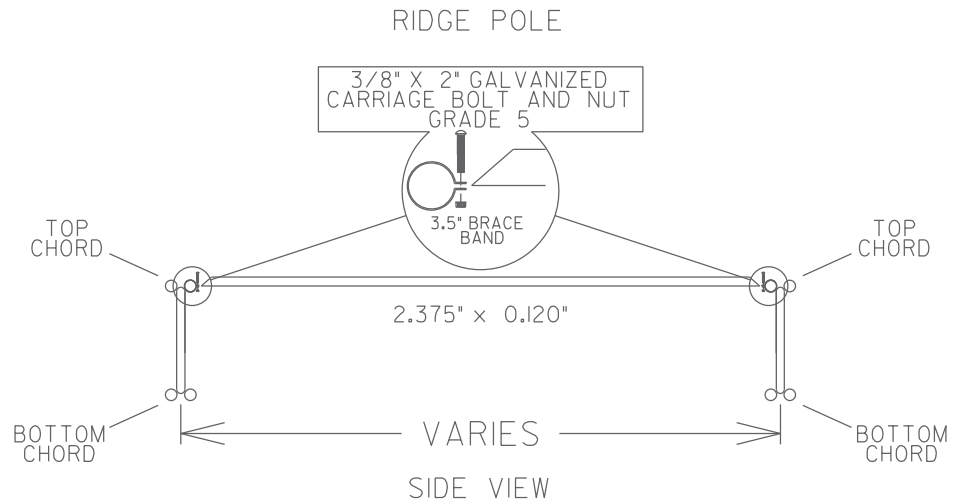
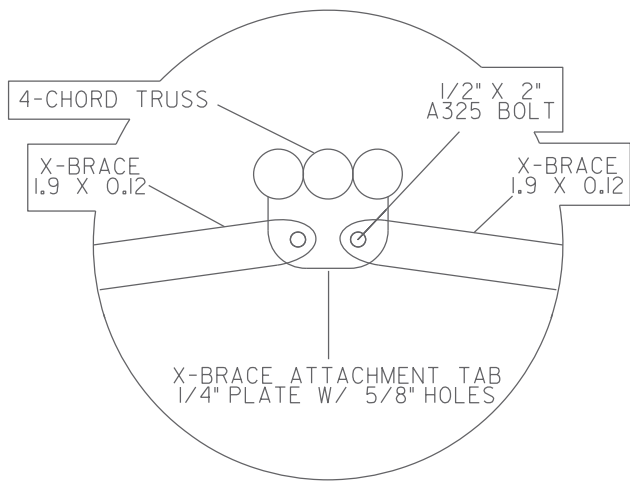

NOT FOR
CONSTRUCTION

ALL INFORMATION IS PROPERTY
OF BIG TOP MANUFACTURING LLC

BIG TOP MANUFACTURING LLC
3255 US HWY 19 NORTH
PERRY, FL 32347
PH: (850) 584 - 7786

CUSTOMER: ZEKELMAN INDUSTRIES
STRUCTURE SIZE: 110 X 291.5 X 48
TRUSS STYLE: 48" FOUR-CHORD
PROJECT NO: 226-093

SHEET DESCRIPTION: LATERAL BRACING DETAILS	
LOCATION: ROCHELLE, IL	
DRAWN BY: G. ANDREWS	SALES REPRESENTATIVE: THOMAS H.
DATE: 04/14/2026	ISSUE: REV 0
	SHEET NO: S-4.1

STAMP ONLY

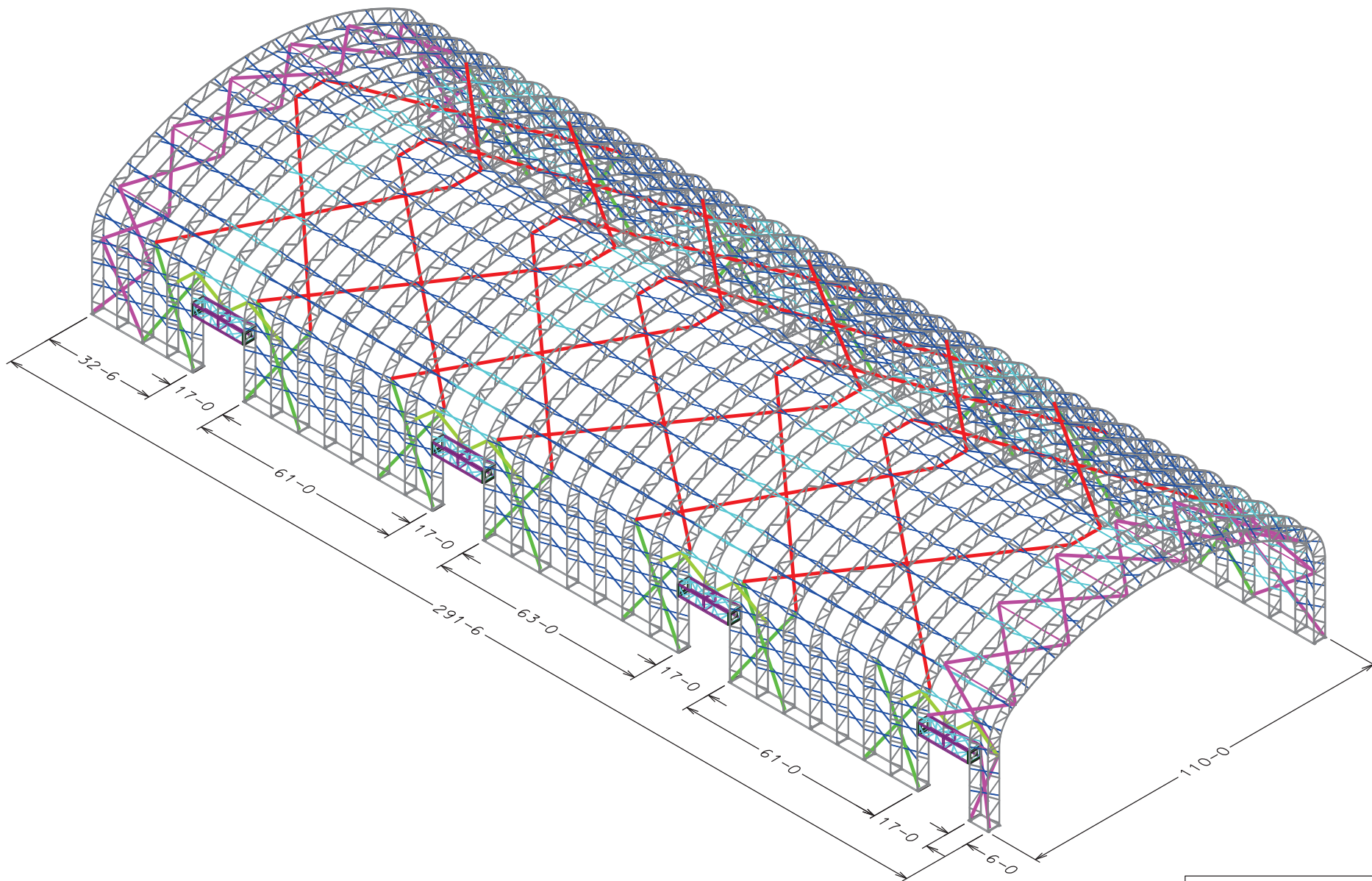

NOT FOR
CONSTRUCTION

ALL INFORMATION IS PROPERTY
OF BIG TOP MANUFACTURING LLC



BIG TOP MANUFACTURING LLC
3255 US HWY 19 NORTH
PERRY, FL 32347
PH: (850) 584 - 7786

CUSTOMER: ZEKELMAN INDUSTRIES
STRUCTURE SIZE: 110 X 291.5 X 48
TRUSS STYLE: 48" FOUR-CHORD
PROJECT NO: 226-093

SHEET DESCRIPTION: CABLE BRACING ISOMETRIC VIEW	
LOCATION: ROCHELLE, IL	
DRAWN BY: G. ANDREWS	SALES REPRESENTATIVE: THOMAS H.
DATE: 04/14/2026	ISSUE: REV 0
SHEET NO: S-5	

STAMP ONLY

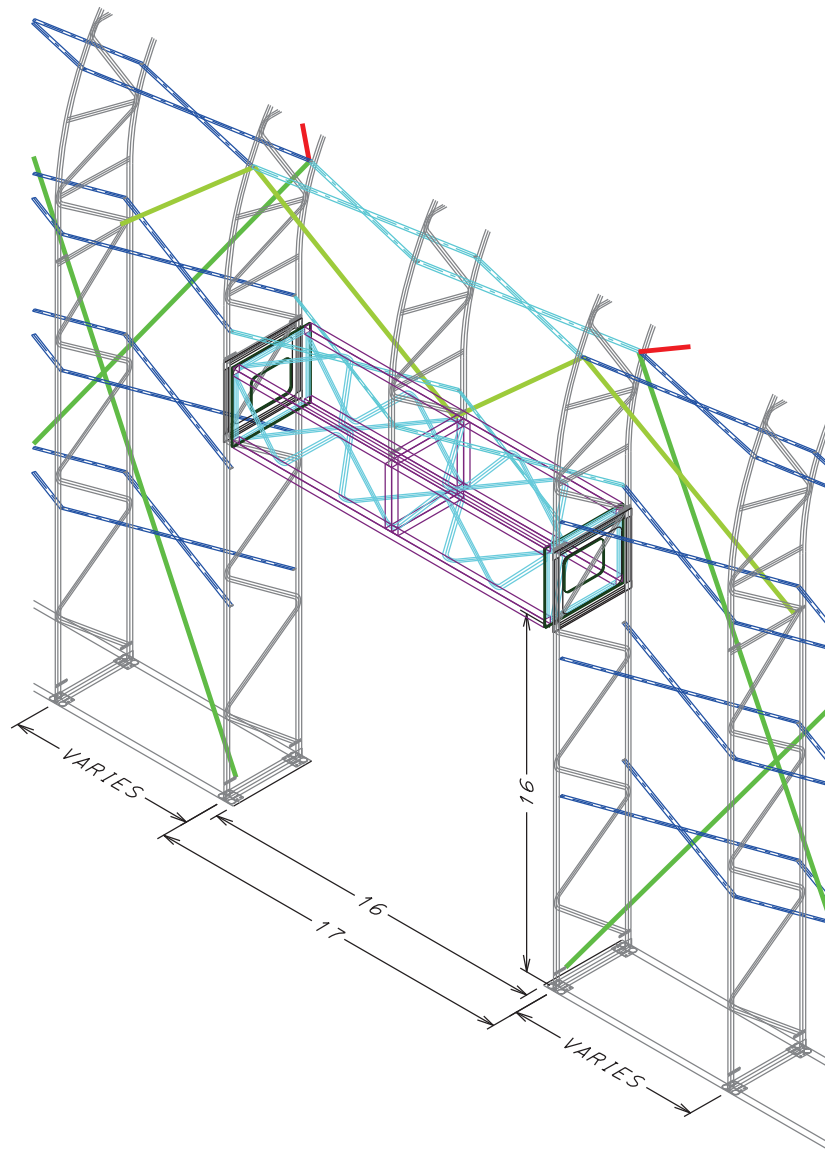
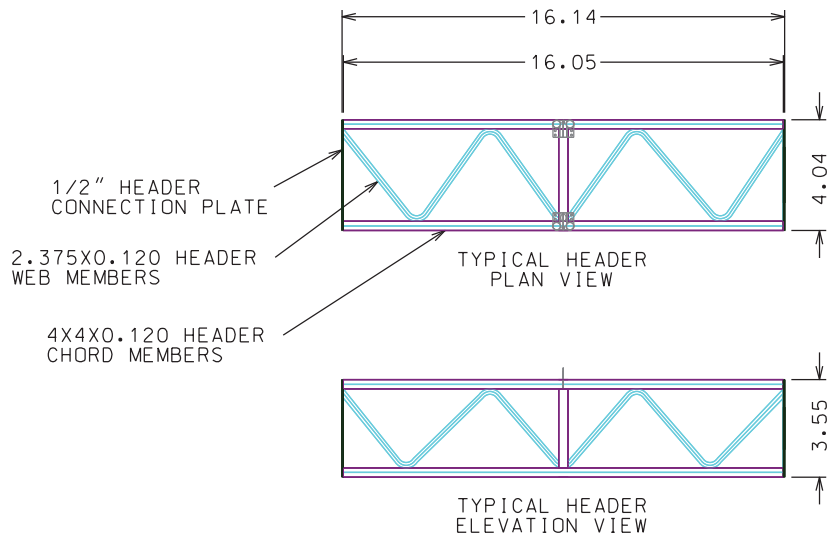

NOT FOR
CONSTRUCTION

ALL INFORMATION IS PROPERTY
OF BIG TOP MANUFACTURING LLC



BIG TOP MANUFACTURING LLC
3255 US HWY 19 NORTH
PERRY, FL 32347
PH: (850) 584 - 7786

CUSTOMER:
ZEKELMAN INDUSTRIES

STRUCTURE SIZE:
110 X 291.5 X 48

TRUSS STYLE:
48" FOUR-CHORD

PROJECT NO:
226-093

SHEET DESCRIPTION:
HEADER DETAILS

LOCATION:
ROCHELLE, IL

DRAWN BY:
G. ANDREWS





DATE:
04/14/2026

SALES REPRESENTATIVE:
THOMAS H.

ISSUE:
REV 0

SHEET NO:
S-5.1

STAMP ONLY

LEGEND	
	CW-1
	CW-2
	TB-1
	TB-2

SEE S-8 FOR DETAILS

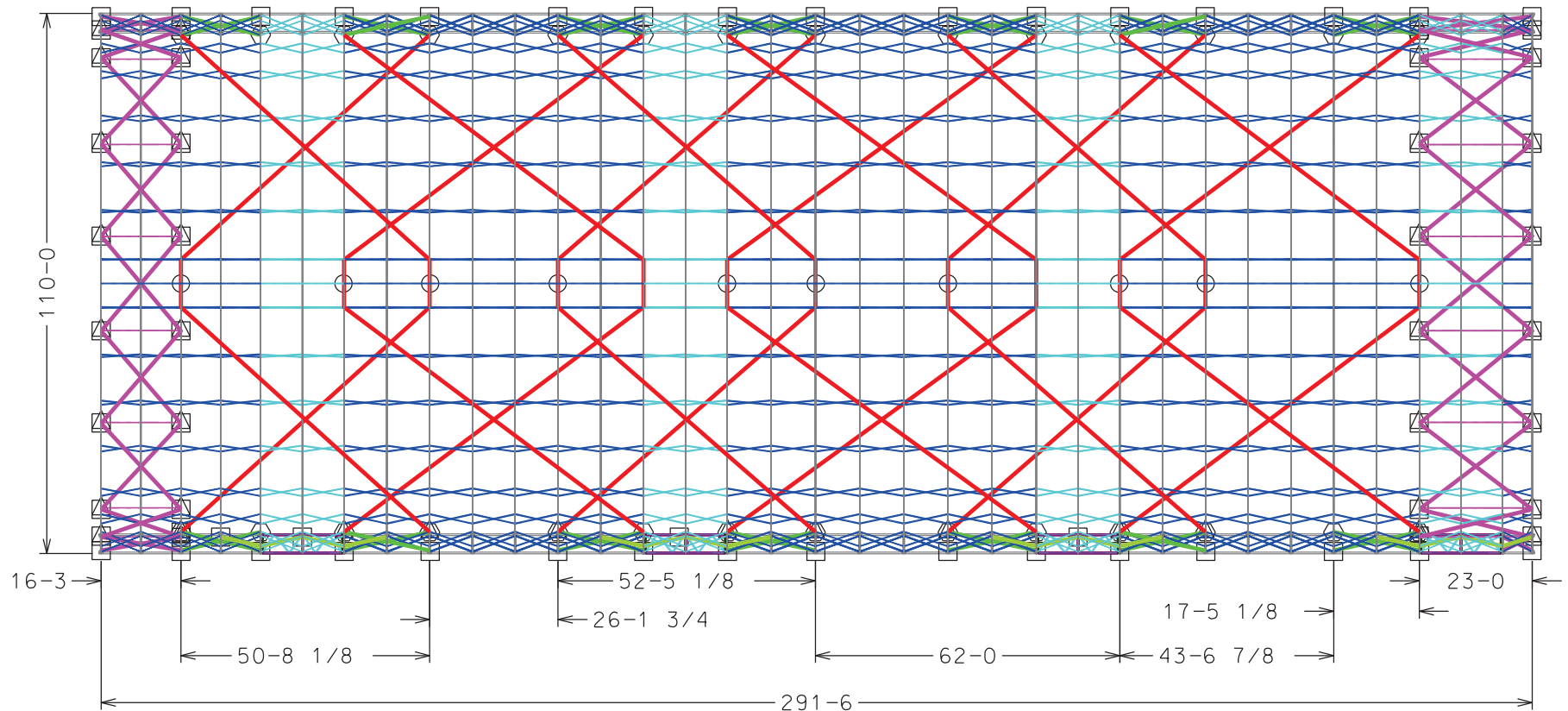

NOT FOR
CONSTRUCTION

ALL INFORMATION IS PROPERTY
OF BIG TOP MANUFACTURING LLC







BIG TOP MANUFACTURING LLC
3255 US HWY 19 NORTH
PERRY, FL 32347
PH: (850) 584 - 7786

CUSTOMER: ZEKELMAN INDUSTRIES
STRUCTURE SIZE: 110 X 291.5 X 48
TRUSS STYLE: 48" FOUR-CHORD
PROJECT NO: 226-093

SHEET DESCRIPTION: CABLE BRACING PLAN VIEW	
LOCATION: ROCHELLE, IL	
DRAWN BY: G. ANDREWS	SALES REPRESENTATIVE: THOMAS H.
DATE: 04/14/2026	ISSUE: REV 0
SHEET NO: S-6	

STAMP ONLY

LEGEND	
	CW-1
	CW-2
	TB-1
	TB-2

SEE S-8 FOR DETAILS

ADDITIONAL HEADER SAFETY CABLE(S)

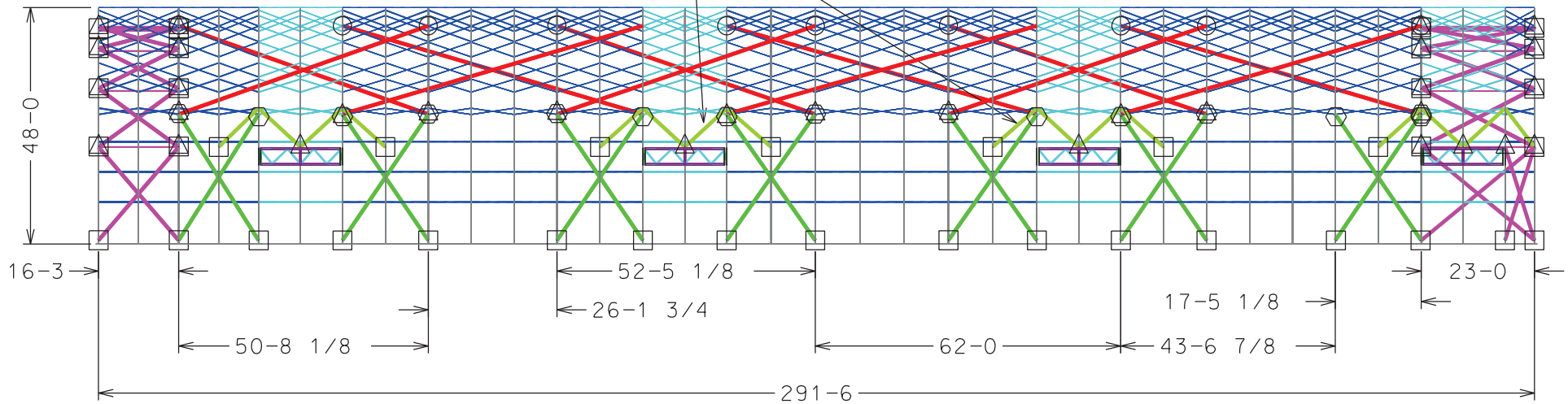

NOT FOR
CONSTRUCTION

ALL INFORMATION IS PROPERTY
OF BIG TOP MANUFACTURING LLC



BIG TOP MANUFACTURING LLC
3255 US HWY 19 NORTH
PERRY, FL 32347
PH: (850) 584 - 7786

CUSTOMER: ZEKELMAN INDUSTRIES
STRUCTURE SIZE: 110 X 291.5 X 48
TRUSS STYLE: 48" FOUR-CHORD
PROJECT NO: 226-093

SHEET DESCRIPTION: CABLE BRACING ELEVATION VIEW	
LOCATION: ROCHELLE, IL	
DRAWN BY: G. ANDREWS	SALES REPRESENTATIVE: THOMAS H.
DATE: 04/14/2026	ISSUE: REV 0
	SHEET NO: S-7

STAMP ONLY



CW-1

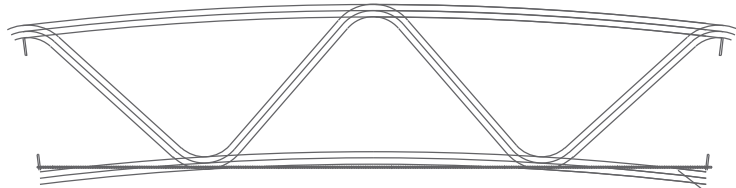

SIDE VIEW



CABLE WRAP

3/8" - 7x19 GAC CABLE
7.2 TONS BREAKING STRENGTH

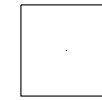

TB-1

THREE 3/8 CABLE CLAMPS
PER CABLE WRAP

5/8" x 9"
TURNBUCKLE

SHELTER TRUSS

5/8" x 9" EYE/JAW TURNBUCKLE
3,500 LBS. WORKING LOAD LIMIT

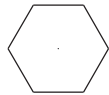

CW-2

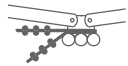
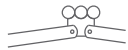

THREE 3/8 CABLE CLAMPS
PER CABLE WRAP



TB-2



5/8" x 9"
TURNBUCKLE

THREE 3/8 CABLE CLAMPS
PER CABLE WRAP

CABLE WRAP

NOT FOR
CONSTRUCTION

ALL INFORMATION IS PROPERTY
OF BIG TOP MANUFACTURING LLC



BIG TOP MANUFACTURING LLC
3255 US HWY 19 NORTH
PERRY, FL 32347
PH: (850) 584 - 7786

CUSTOMER:

ZEKELMAN INDUSTRIES

STRUCTURE SIZE:

110 X 291.5 X 48

TRUSS STYLE:

48" FOUR-CHORD

PROJECT NO:

226-093

SHEET DESCRIPTION:

CABLE BRACING DETAILS

LOCATION:

ROCHELLE, IL

DRAWN BY:

G. ANDREWS

SALES REPRESENTATIVE:

THOMAS H.

DATE:

04/14/2026

ISSUE:

REV 0

SHEET NO:

S-8

STAMP ONLY

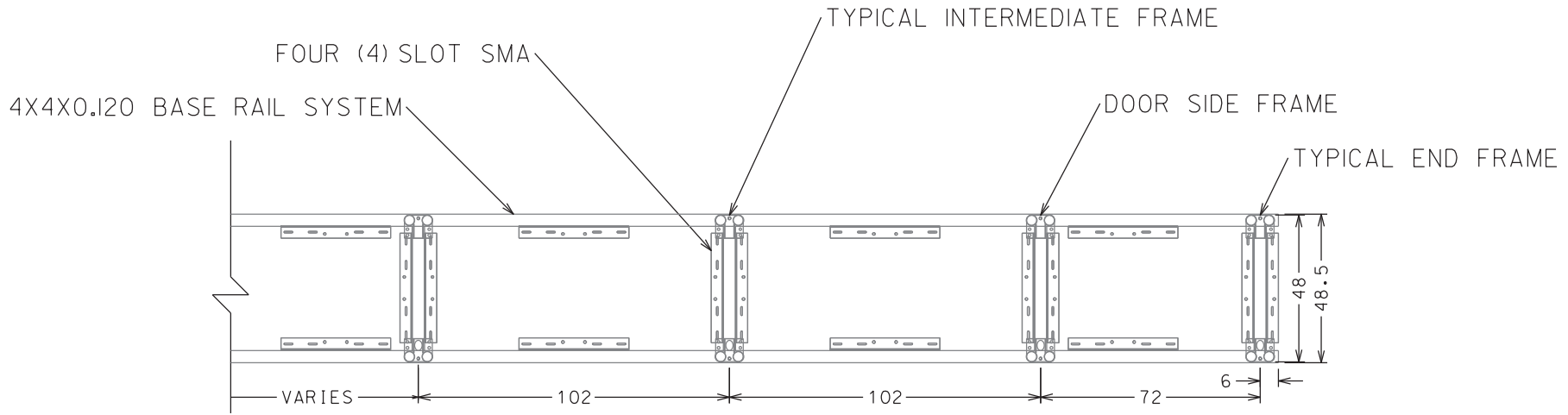

4X4X3/8X36 SOIL
MODIFICATION ANGLE (SMA)

40" SOIL ANCHOR
FOUR (4) PLACES

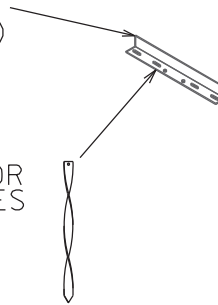

NOT FOR
CONSTRUCTION

ALL INFORMATION IS PROPERTY
OF BIG TOP MANUFACTURING LLC



BIG TOP MANUFACTURING LLC
3255 US HWY 19 NORTH
PERRY, FL 32347
PH: (850) 584 - 7786

CUSTOMER:
ZEKELMAN INDUSTRIES

STRUCTURE SIZE:
110 X 291.5 X 48

TRUSS STYLE:
48" FOUR-CHORD

PROJECT NO:
226-093

SHEET DESCRIPTION:
BASE ANCHOR DETAILS

LOCATION:
ROCHELLE, IL

DRAWN BY:
G. ANDREWS

DATE:
04/14/2026

SALES REPRESENTATIVE:
THOMAS H.

ISSUE:
REV 0

SHEET NO:
S-9.1

STAMP ONLY

48" FOUR-CHORD

FABRIC	
COLOR	2218 WHITE
WEIGHT	22 OZ

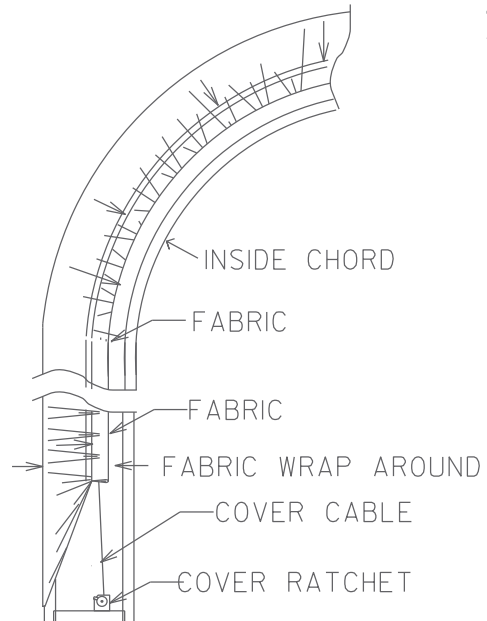

COVER TENSIONING FRAME END
(LOOKING OUTSIDE IN)

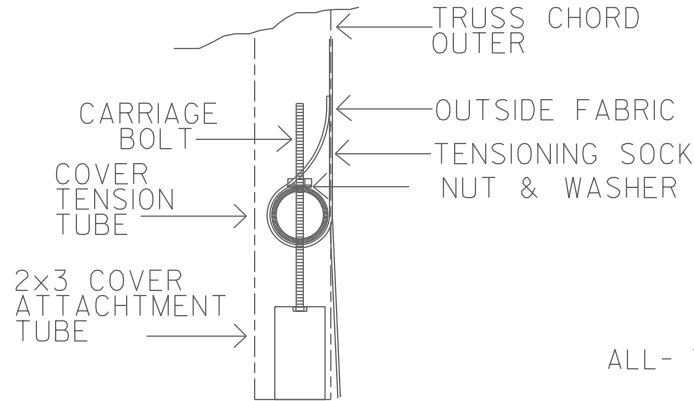

VIEW C

ALL-THREAD COVER TENSIONING ALONG SIDE
(INSIDE LOOKING OUT)

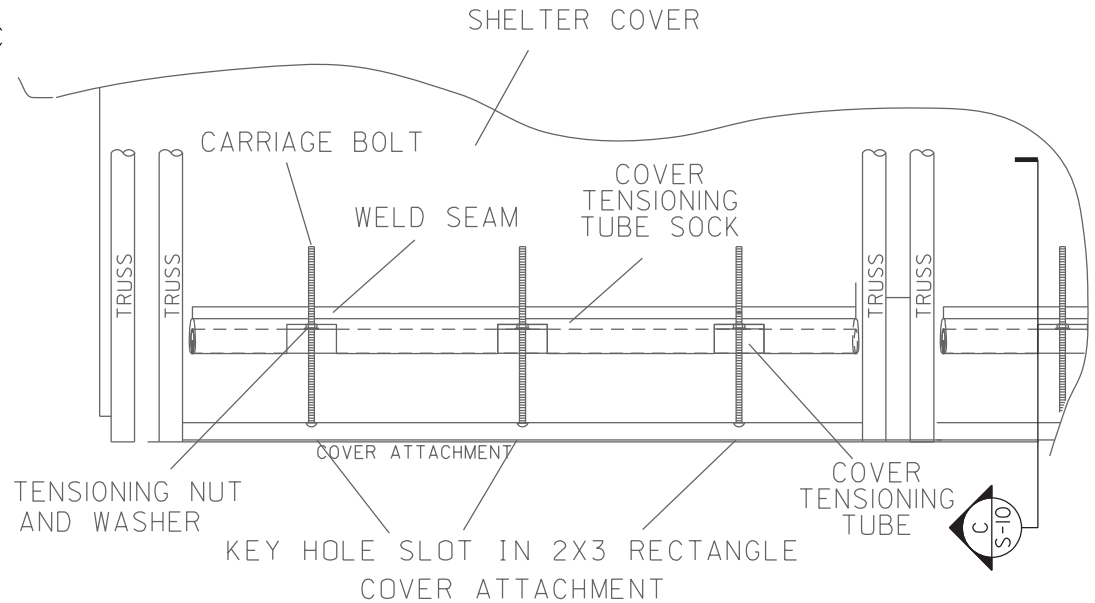

SHELTER COVER

**NOT FOR
CONSTRUCTION**

ALL INFORMATION IS PROPERTY
OF BIG TOP MANUFACTURING LLC

BIG TOP MANUFACTURING LLC
3255 US HWY 19 NORTH
PERRY, FL 32347
PH: (850) 584 - 7786

CUSTOMER: ZEKELMAN INDUSTRIES
STRUCTURE SIZE: 110 X 291.5 X 48
TRUSS STYLE: 48" FOUR-CHORD
PROJECT NO: 226-093

SHEET DESCRIPTION: FABRIC ATTACHMENT DETAILS	
LOCATION: ROCHELLE, IL	
DRAWN BY: G. ANDREWS	SALES REPRESENTATIVE: THOMAS H.
DATE: 04/14/2026	ISSUE: REV 0
SHEET NO: S-10	

STAMP ONLY

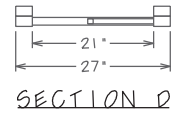
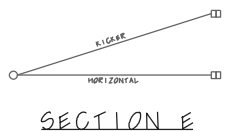
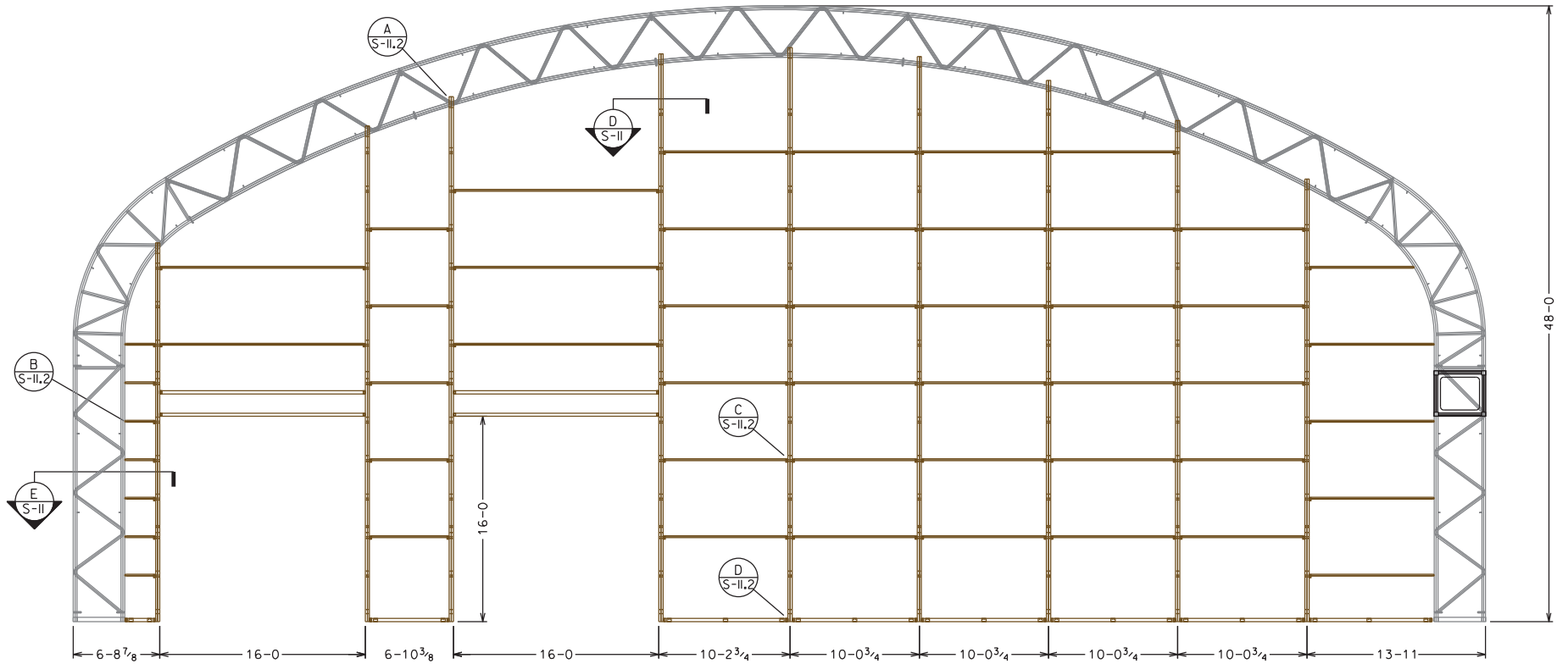

TRUSS CHORD DOUBLE 2 X 3" X 0.085"
 50,000 PSI YIELD
 55,000 PSI TENSILE
 HORIZONTAL BRACE 1.75 X 1.75" X 0.085"
 50,000 PSI YIELD
 55,000 PSI TENSILE
 DIAGONAL BRACE 1.5 X 1.5" X 0.065"
 50,000 PSI YIELD
 55,000 PSI TENSILE

NOT FOR
 CONSTRUCTION

STAMP ONLY

ALL INFORMATION IS PROPERTY
 OF BIG TOP MANUFACTURING LLC

BIG TOP MANUFACTURING LLC
 3255 US HWY 19 NORTH
 PERRY, FL 32347
 PH: (850) 584 - 7786

CUSTOMER: ZEKELMAN INDUSTRIES
STRUCTURE SIZE: 110 X 291.5 X 48
TRUSS STYLE: 48" FOUR-CHORD
PROJECT NO: 226-093

SHEET DESCRIPTION: END PANEL 1 - LAYOUT	
LOCATION: ROCHELLE, IL	
DRAWN BY: G. ANDREWS	SALES REPRESENTATIVE: THOMAS H.
DATE: 04/14/2026	ISSUE: REV 0
SHEET NO: S-11	

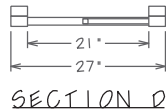
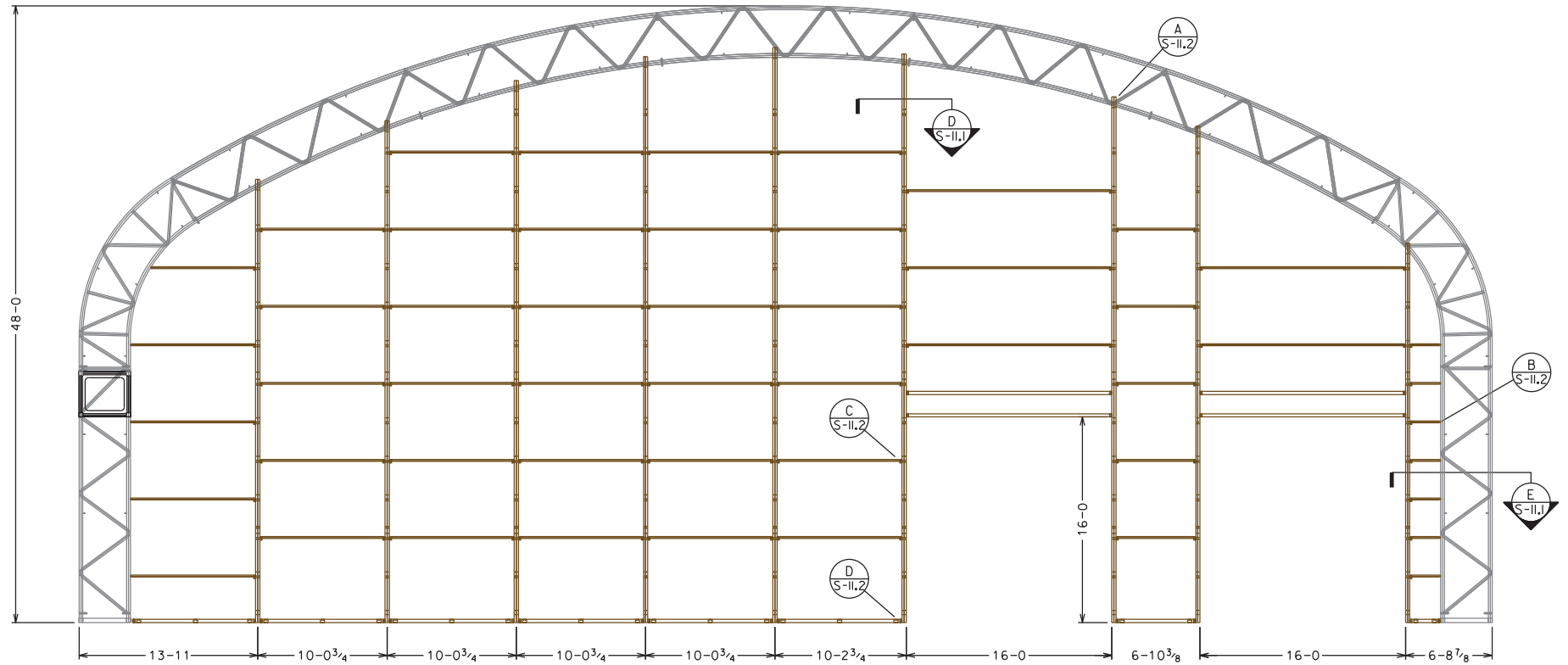

TRUSS CHORD DOUBLE 2 X 3" X 0.085"
 50,000 PSI YIELD
 55,000 PSI TENSILE
 HORIZONTAL BRACE 1.75 X 1.75" X 0.065"
 50,000 PSI YIELD
 55,000 PSI TENSILE
 DIAGONAL BRACE 1.5 X 1.5" X 0.065"
 50,000 PSI YIELD
 55,000 PSI TENSILE

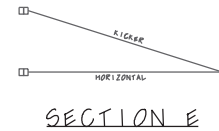

NOT FOR
 CONSTRUCTION

ALL INFORMATION IS PROPERTY
 OF BIG TOP MANUFACTURING LLC



BIG TOP MANUFACTURING LLC
 3255 US HWY 19 NORTH
 PERRY, FL 32347
 PH: (850) 584 - 7786

CUSTOMER:
 ZEKELMAN INDUSTRIES

STRUCTURE SIZE:
 110 X 291.5 X 48

TRUSS STYLE:
 48" FOUR-CHORD

PROJECT NO:
 226-093

SHEET DESCRIPTION:
 END PANEL 2 - LAYOUT

LOCATION:
 ROCHELLE, IL

DRAWN BY:
 G. ANDREWS

DATE:
 04/14/2026

SALES REPRESENTATIVE:
 THOMAS H.

ISSUE:
 REV 0

SHEET NO:
 S-11.1

STAMP ONLY

DETAIL A
VERTICAL TRUSS TOP

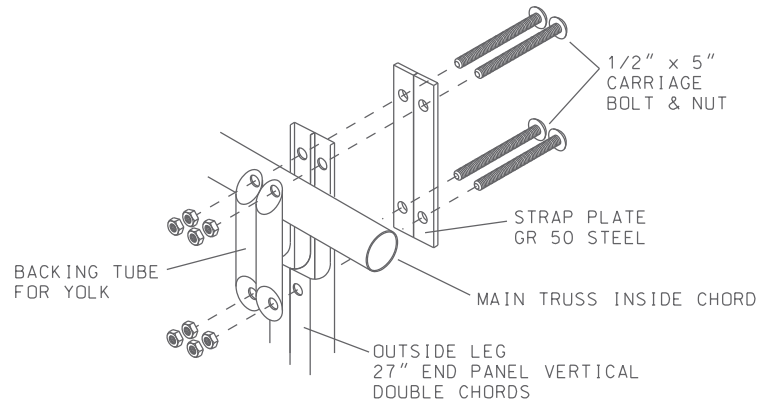

DETAIL B
BRACE BAND DETAIL

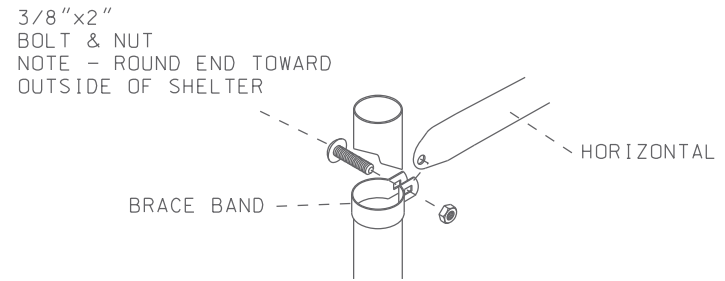

DETAIL C

HORIZONTAL TO
END PANEL VERTICAL DETAIL

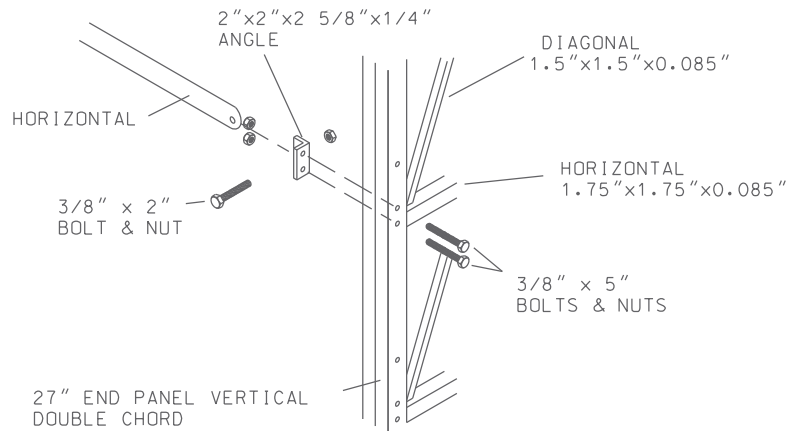

DETAIL D
VERTICAL TRUSS BASE DETAIL

NOTE: ALL ANGLES ARE BOLTED USING
3/8" X 3" BOLTS AND NUTS.
ENSURE THE THREADS ARE ALL FACING
THE INSIDE OF THE SHELTER.

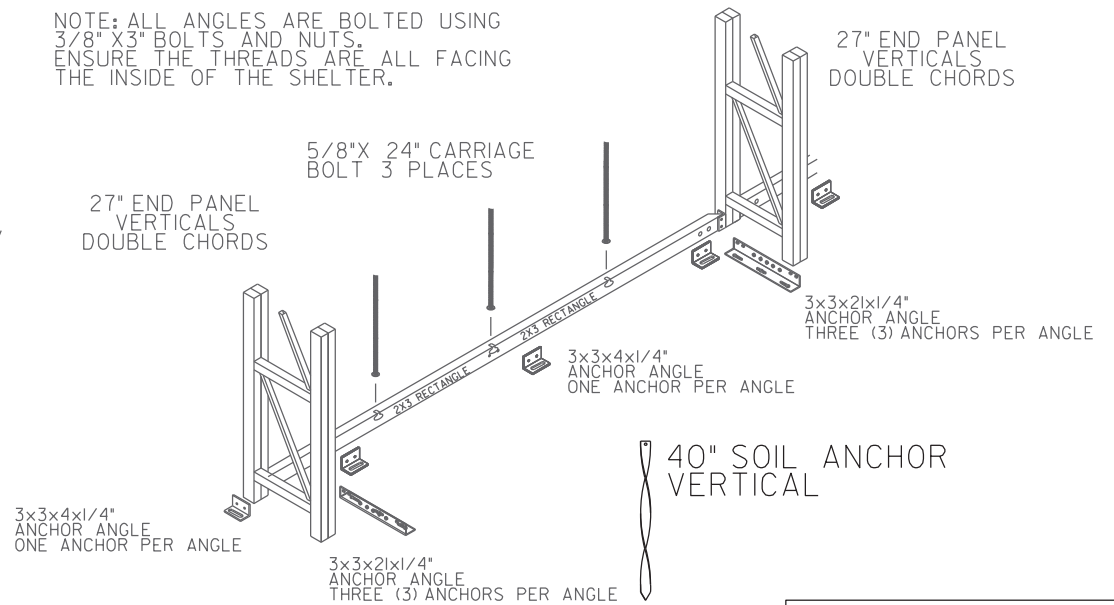

NOT FOR
CONSTRUCTION

ALL INFORMATION IS PROPERTY
OF BIG TOP MANUFACTURING LLC



BIG TOP MANUFACTURING LLC
3255 US HWY 19 NORTH
PERRY, FL 32347
PH: (850) 584 - 7786

CUSTOMER: ZEKELMAN INDUSTRIES
STRUCTURE SIZE: 110 X 291.5 X 48
TRUSS STYLE: 48" FOUR-CHORD
PROJECT NO: 226-093

SHEET DESCRIPTION: END PANEL - DETAILS	
LOCATION: ROCHELLE, IL	
DRAWN BY: G. ANDREWS	SALES REPRESENTATIVE: THOMAS H.
DATE: 04/14/2026	ISSUE: REV 0
SHEET NO: S-11.2	

STAMP ONLY