

ZONING TABLE BUSINESS PROFESSIONAL DISTRICT			
	REQUIRED	EXISTING	PROPOSED
LOT SIZE	12,000 SF	31,519 SF	UNCHANGED
FRONTAGE	100 FT	100.94 FT	UNCHANGED
FRONT	25 FT	31.6 FT	UNCHANGED
SIDE	6 FT	8.4 FT	11.0 FT
REAR	15 FT	117.9 FT	64.4 FT
BUILDING COVERAGE	35% MAX	9.8%	13.5%
IMPERVIOUS COVERAGE	15% MAX	33.0%	36.3%
TOTAL COVERAGE	50% MAX	42.8%	49.8%
BUFFER STRIP	10 FT	8.4 FT	11 FT

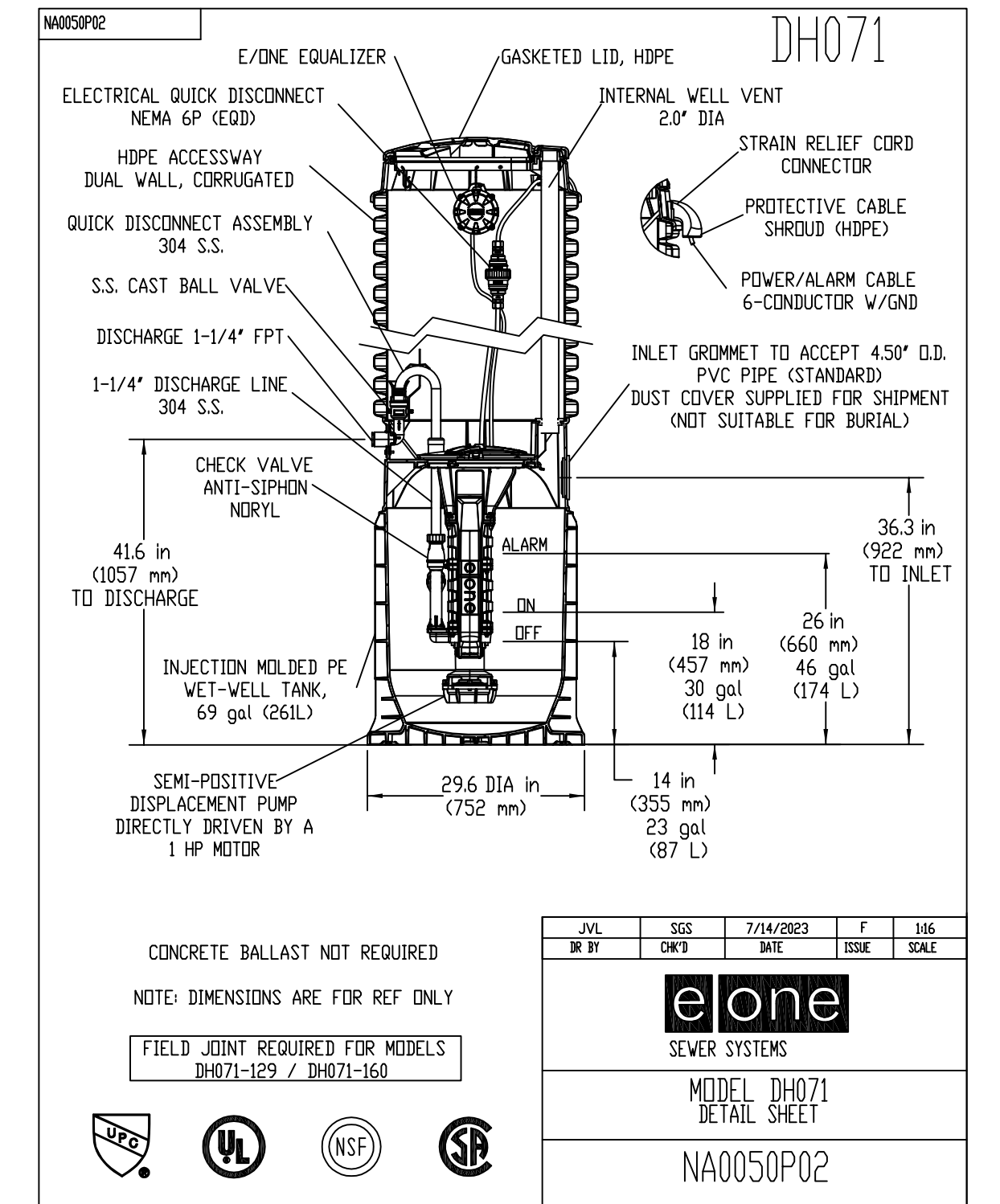

- NOTES:**
- LICENSED DRAIN LAYER TO INSTALL SERVICE LINES IN ACCORDANCE WITH TOWN OF RANDOLPH SEWER AND WATER DEPARTMENT REGULATIONS.
  - IF A SEPARATION OF LESS THAN 10 FEET IS PROVIDED BETWEEN THE WATER SERVICE AND THE SEWER, THE WATER SERVICE MUST BE SLEEVED.
  - THE CONTRACTOR SHALL CONFIRM ALL EXISTING UTILITY LOCATIONS AND INVERT ELEVATIONS PRIOR TO CONSTRUCTION.
  - BUILDING CONNECTIONS SHALL BE BEDDED IN 3/4" MINIMUM CRUSHED STONE TO AT LEAST HALF THE PIPE DIAMETER.
  - ELEVATION DATUM IS NAVD 88
  - THIS LAND IS SUBJECT TO ANY EASEMENTS, RIGHTS-OF-WAY, RESTRICTIONS, RESERVATIONS, OR OTHER LIMITATIONS WHICH MAY BE REVEALED BY AN EXAMINATION OF THE TITLE.
  - THE OFFSETS AS SHOWN ON THIS PLAN ARE NOT TO BE USED FOR THE ESTABLISHMENT OF PROPERTY LINES OR FOR THE ESTABLISHMENT OF ANY PROPOSED CONSTRUCTION.
  - THIS PLAN WAS PREPARED FOR THE EXCLUSIVE USE AND PURPOSE FOR THE PARTY STATED HEREON AND SHALL NOT BE USED BY ANY THIRD PARTY WITHOUT THE EXPRESSED WRITTEN PERMISSION OF BORDERLAND ENGINEERING, INC.
  - THIS SITE DOES NOT FALL WITHIN A SPECIAL HAZARDOUS FLOOD AREA AS DESIGNATED BY F.I.R.M. COMMUNITY PANEL NUMBER 250210216F EFFECTIVE DATE: JULY 8, 2025.
  - FOR THE LOW-PRESSURE SEWER LINE, IF LESS COVER IS PRESENT IN CERTAIN AREAS, INSULATION MUST BE PROVIDED FOR FROST PROTECTION.
  - UTILITIES ARE PLOTTED FROM FIELD LOCATION AND ANY RECORD INFORMATION AVAILABLE, AND SHOULD BE CONSIDERED APPROXIMATE. OTHER UTILITIES MAY EXIST WHICH ARE NOT EVIDENT OR FOR WHICH RECORD INFORMATION WAS NOT AVAILABLE. CONTRACTORS (IN ACCORDANCE WITH MASSACHUSETTS LAW) MUST CONTACT ALL UTILITY COMPANIES BEFORE EXCAVATING AND DRILLING. ALSO, CALL "DIG-SAFE" AT 1(888)344-7233 F1(888)DIG-SAFE.

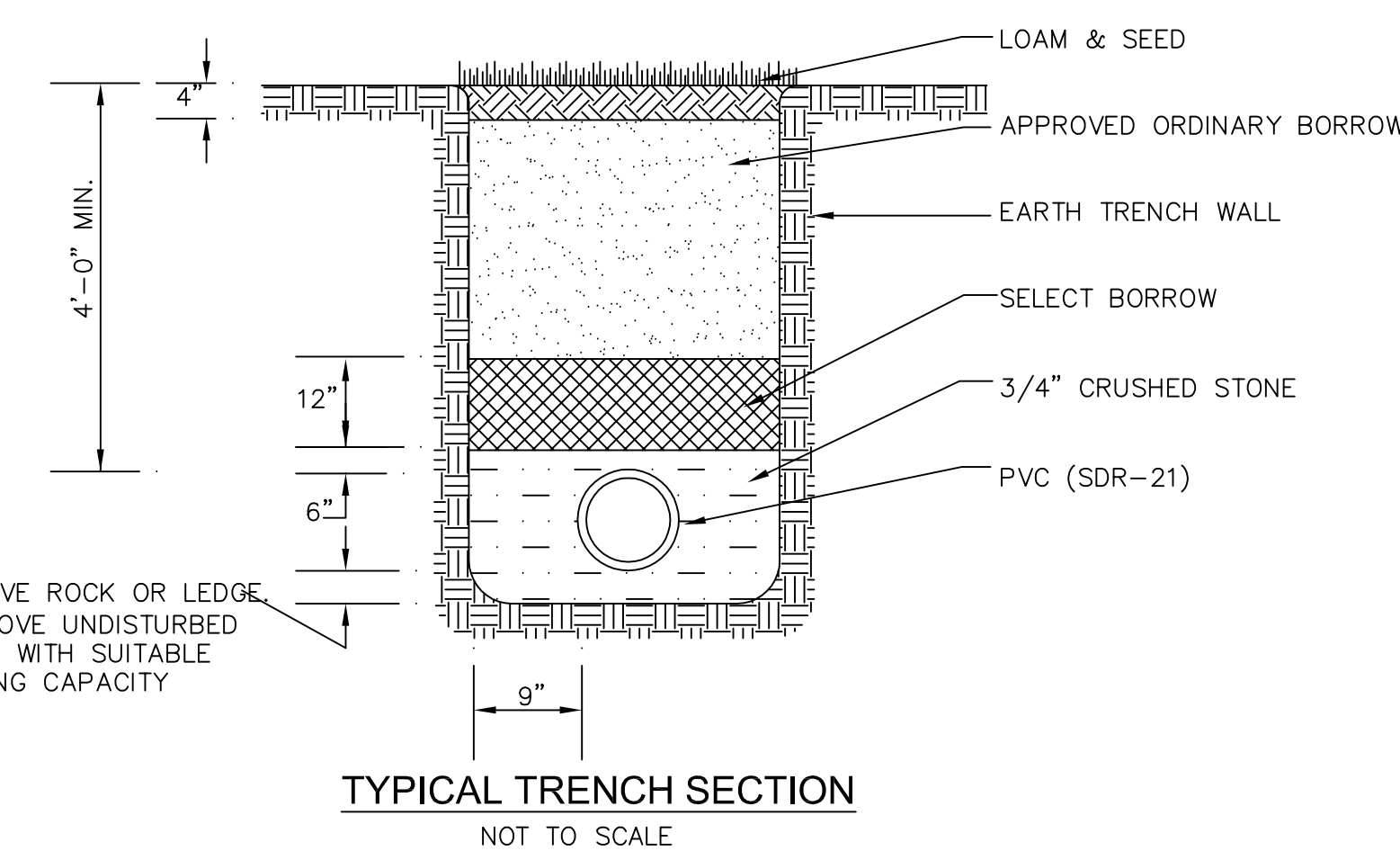
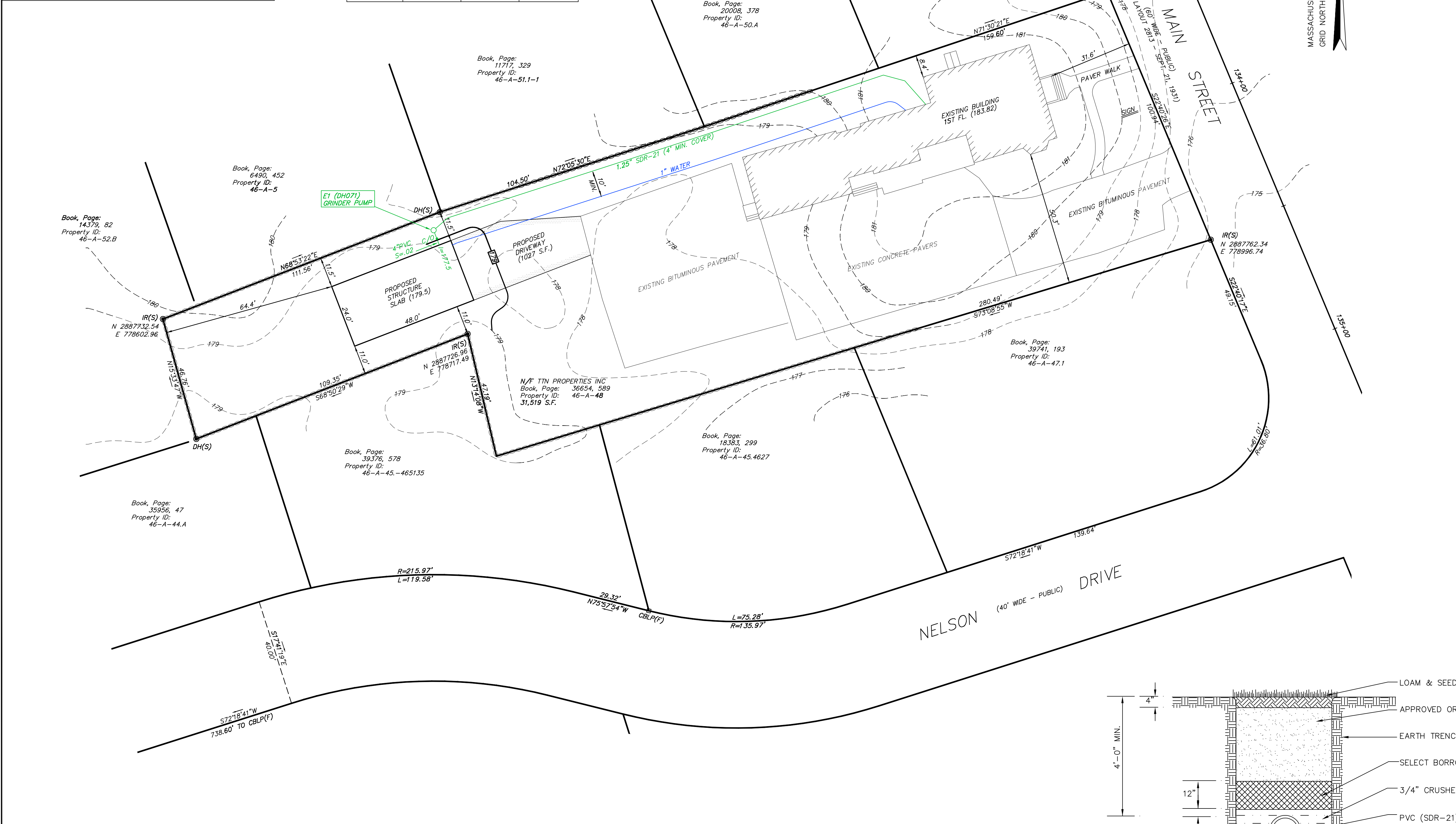

- PLAN REFERENCES:**
- Plan # 305-757
  - Plan # 316-1249
  - Plan # 389-65
  - Plan # D2833-263
  - Plan # D3918-454
  - Plan # D4004-60
  - Plan # D4122-281

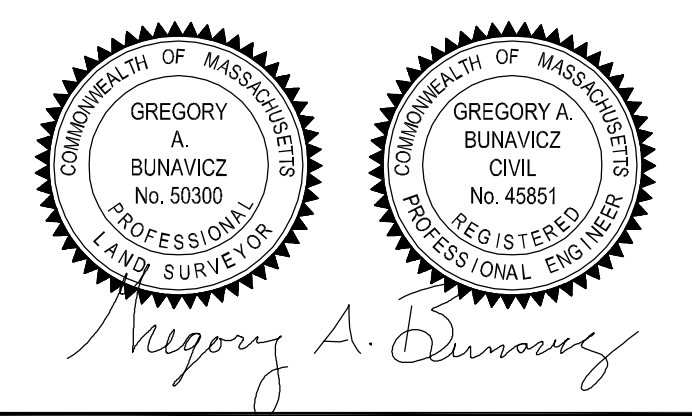
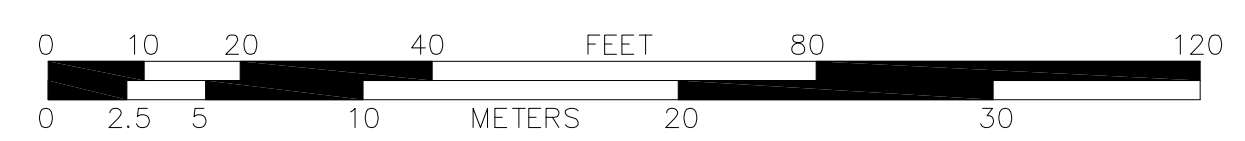

**BORDERLAND ENGINEERING, INC.**

500 Tumpike Street  
Canton, MA 02021

781-963-9500  
www.borelandeng.com

**PROPOSED STRUCTURE SITE PLAN  
IN  
RANDOLPH, MASSACHUSETTS**

**420 NORTH MAIN STREET**

PREPARED FOR: TTN PROPERTIES INC  
9 DRAKE STREET  
EASTON, MA 02375

DRAWING SCALE: 1 INCH = 20 FEET

DATE: FEB. 20, 2026 PROJECT NUMBER: P2943