



City of Rio Communities Council Regular Business Meeting
City Council Chambers - 360 Rio Communities Blvd
Rio Communities, NM 87002
Monday, September 25, 2023 6:00 PM
Agenda

Please silence all electronic devices.

Mayor - Joshua Ramsell
Mayor Pro Tem - Margaret R. Gutjahr
Council - Arthur Apodaca, Lawrence R. Gordon, Jimmie Winters

Call to Order
Pledge of Allegiance
Roll Call
Approval of Agenda

Approval of Consent Agenda (The consent agenda is approved by a single motion. Any member of the Council may request an item to be transferred to the regular agenda from the consent agenda without discussion or vote.)

- 1. Minutes for the City Council Workshop & Regular Business Meeting (09/11/2023) & Accounts Payable**

Presentation:

- 2. Valencia County Business Incubator - Ben Romero**

Public Hearing - For the purpose of Ordinance 2023 - XX Comcast Franchise Agreement

Motion and roll call vote to recess Regular Business Meeting session and to go into Public Hearing

- **Consideration of Ordinance 2023 - XX Comcast Franchise Agreement**

Motion and roll call vote to go back into Regular Business Meeting session

- 3. Discussion, Consideration, and Decision - Ordinance 2023 - XX Comcast Franchise Agreement**

Public Comment: The Council will take public comments in written format. These should be emailed to admin@riocommunities.net through 4:45 PM on, September 25, 2023. These comments will be distributed to all Councilors for review. **If you wish to speak during the public comment session**, the Council will allow each member of the public to three (3) minutes to address the Council. Both the public and Council will follow rules of decorum. Give your name and where you live. The public will direct comments to the City Council. Comment(s) will not be disruptive or derogatory.

The Council will not take action or engage in discussion regarding the comments made or received, but when appropriate the matters raised may be referred to staff or others for further review. Both the public and Council will follow rules of decorum. Derogatory Comments or matters under litigation will not be allowed and any person

NOTE: THIS AGENDA IS SUBJECT TO REVISION UP TO 72 HOURS PRIOR TO THE SCHEDULED MEETING DATE AND TIME (NMSA 10-15-1 F). A COPY OF THE AGENDA MAY BE PICKED UP AT CITY HALL, 360 RIO COMMUNITIES BLVD, RIO COMMUNITIES, NM 87002. IF YOU ARE AN INDIVIDUAL WITH A DISABILITY WHO IS IN NEED OF A READER, AMPLIFIER, QUALIFIED SIGN LANGUAGE INTERPRETER OR ANY OTHER FORM OF AUXILIARY AND OR SERVICE TO ATTEND OR PARTICIPATE IN THE MEETING, PLEASE CONTACT THE MUNICIPAL CLERK AT 505-861-6803 AT LEAST ONE WEEK PRIOR TO THE MEETING OR AS SOON AS POSSIBLE.

or persons addressing the Council are liable for their own statements, not the Council. Statements are limited to a maximum of 3 minutes duration. Please give your name and where you live for the record.

Manager Report

4. **A. 10th Anniversary Celebration Update**
 - B. City Hall Roof
 - C. City Hall Parking Lot
 - D. Sheriff Department Agreement

Action Items

5. **Discussion, Consideration, and Decision – Approval of Contract- DHSEM Invitation to Bid #2023-0101**
6. **Discussion, Consideration, and Decision – Approval of Contract- Drainage Improvements Invitation to Bid # 2023-0102.**
7. **Discussion, Consideration, and Decision – Resolution #2023-XX Participation in Capital Outlay Program Administered by New Mexico Department of Transportation**
8. **Discussion, Consideration, and Decision – Council Workshops**

Council Discussion

Executive Session - For the purpose of Limited Personnel Matters - Employment status of Public Works supervisor and temporary Public Works employee pursuant to NMSA 10-15-1(H)(2) and for the discussion of the purchase, addition or disposal of real property or water rights by the public body pursuant to NMSA 10-15-1(H)(8)

Motion and roll call vote to go into close session

Motion and roll call vote to go back into the regular business meeting session

Welcome everyone back and statement by the Mayor: The Governing Body of the City of Rio Communities, New Mexico, hereby states that on September 25, 2023 a closed executive session was held for purpose of Limited Personnel matters employment status of Public Works supervisor and temporary Public Works employee pursuant to NMSA 10-15-1(H)(2) - Limited Personnel Matters and for the discussion of the purchase, addition or disposal of real property or water rights by the public body pursuant to NMSA 10-15-1(H)(8)

Action Items

9. **Recommendation, Discussion, Consideration and Decision - For the purpose of Limited Personnel matters employment status of Public Works supervisor and temporary Public Works employee pursuant to NMSA 10-15-1(H)(2) - Limited Personnel Matters and for the discussion of the purchase, addition or disposal of real property or water rights by the public body pursuant to NMSA 10-15-1(H)(8)**

Adjourn

Please join us from the comfort and safety of your own home by entering the following link: @
<https://www.facebook.com/riocommunities>

NOTE: THIS AGENDA IS SUBJECT TO REVISION UP TO 72 HOURS PRIOR TO THE SCHEDULED MEETING DATE AND TIME (NMSA 10-15-1 F). A COPY OF THE AGENDA MAY BE PICKED UP AT CITY HALL, 360 RIO COMMUNITIES BLVD, RIO COMMUNITIES, NM 87002. IF YOU ARE AN INDIVIDUAL WITH A DISABILITY WHO IS IN NEED OF A READER, AMPLIFIER, QUALIFIED SIGN LANGUAGE INTERPRETER OR ANY OTHER FORM OF AUXILIARY AND OR SERVICE TO ATTEND OR PARTICIPATE IN THE MEETING, PLEASE CONTACT THE MUNICIPAL CLERK AT 505-861-6803 AT LEAST ONE WEEK PRIOR TO THE MEETING OR AS SOON AS POSSIBLE.



City of Rio Communities Council Workshop
City Council Chambers - 360 Rio Communities Blvd
Rio Communities, NM 87002
Monday, September 11, 2023 3:00 PM
Minutes

Please silence all electronic devices.

Call to Order

Mayor Joshua Ramsell called the regular workshop to order at 3:09 pm.

Attendees

PRESENT

Governing Body

Mayor Joshua Ramsell
Mayor Pro-tem Margaret R. Gutjahr
Councilor Arthur Apodaca
Councilor Lawrence Gordon
Councilor Jimmie Winters

Staff

Manager Dr. Martin Moore
Clerk Elizabeth Adair
Finance Officer Stephanie Finch (virtual)
Accounting Specialist/CPO Angela Valadez
Fire Chief Andrew Tabet
Attorney Randall Van Vleck
Police Chief Felix Nunez

Accounts payable report (See packet)

Accounting Specialist/CPO Angela Valadez went over everything over \$500.00. Councilor Gutjahr asked if the payable to Valencia County fiscal office was for 911 or for animal control services. Accounting Specialist/CPO Angela Valadez stated it was for Valencia County fire department medical direction and it is for the whole year.

Resolution 2023 - XX Authorizing the Assignment of Authorized Officer(s) and Agent(s)

(Manager/Finance Officer)

Finance Officer Finch explained there are different oversight agencies for capital outlay and they all require something different. The oversight for this particular grant is through the environment department, and they are having us approve the grant agreement by resolution. Finch stated they were hoping to have Dr. Moore sign the grant agreement and herself or Angela sign the notice of obligations and request for reimbursements. This is for the storm water and drainage infrastructure grant.

Grant Agreement for Rio Communities 23-H2509-GF (Manager/Finance Officer)

Manager Dr. Moore explained the grant agreement for \$350,000.00 is for the storm water drainage. It is to plan phase 1 and they have a plan in place. It is a reimbursement grant we pay for, and they reimburse us. What he recommends is to approve this agreement and come back to Council with HDI engineering and talk about recommendations for a specific project.

City Hall Parking Lot upgrades (Manager/Finance Officer)

Manager Dr. Moore stated in anticipation of the upcoming celebration and winter, while talking with our acting supervisor in public works, he has looked at parking lot and the cracks are widening. He then went over the options that were quoted. Option 1 is fog sealing coat which will last

between six months to a year. Option 2 is a half inch asphalt overlay that they would put over the existing asphalt. Manager Dr. Moore said he recommends option 2 and then a yearly maintenance afterwards. It is a difference in price of \$61,000.00 to do the half inch overlay and we will have to restripe the parking lot. It will give some more life to the parking lot. Councilor Winters asked if this was just front or front and back. Manager Dr. Moore explained it is both front and back. Councilor Apodaca asked what funds would be used for this. Manager Dr. Moore explained we would be utilizing funds from the capital budget that was budgeted for city hall complex. Councilor Gutjahr asked if utilizing this funding would have an impact on our renovation. Manager Dr. Moore said yes it will. He further said we have found that there are areas we are recognizing, one is our fire alarms, another is electric wiring. We will know more after our architect comes in. Councilor Gutjahr asked for clarification this would come out of the \$300,000 not out of the \$600,000. Manager Dr. Moore said yes, it is not a grant.

Ordinance 2023 - XX - Chapter 10 Local Economic Development Act (LEDA) (Manager/Council)

Manager Dr. Moore explained that Jill Sweeney is hoping to make it to the meeting this evening. She worked with our attorney's office putting together this ordinance and the next one that has to do with our economic developer toolbox. These match up with the changes in state law.

Ordinance 2023 - XX - Chapter 10 Industrial Revenue Bond Policy (IRB) and Local Economic Development Act (LEDA) (Manager/Council)

Manager Dr. Moore explained we have a copy of policy as part of the ordinance and it is substantial. He stated he feels comfortable with it and we need to move forward. Councilor Winters asked if these are the last two items in our toolbox that we are anticipating at this point. Manager Dr. Moore said there may be others coming through the Mortgage Finance Authority requesting a type of plan being put in place for us to be eligible for work force type housing. Councilor Gutjahr said these two items will allow us to work with an entity incoming in unless housing is going to be involved. Manager Dr. Moore said the housing may not come under these two ordinances. He cannot say for sure if you have a LEDA retail and they have a security housing component that it will tie in. He stated we will have to get that other component in place in order to utilize some of the tools we will need in the toolbox. Councilor Gutjahr said for clarification looking at Arcosa, would we have needed the mortgage financing component for that. Manager Dr. Moore explained no we wouldn't.

Authorizing Fund for Demolition & Cleanup of Dangerous & Nuisance Properties (Manager/Council)

Manager Dr. Moore said this is one item that has been a challenge internally. He has spoken with the Mayor about what we can do to get some of these buildings down. He further gave examples of the purple building that one is so tangled up there are so many owners. If we took it down, we would have to eat the cost. We have talked about them and if we want to spend the kind of money to clean them up. We are talking about properties that have environmental issues or ground filled issues and continued the discussion. Councilor Winters asked how many properties we currently have on the list. Manager Dr. Moore said we have at least four on our dangerous or nuisance that are a major. Councilor Apodaca said on the purple building property are you saying that it would cost us 100k for just that property. Manager Dr. Moore said we do not know how much that one will cost us, but we know there is more than one we are dealing with. Councilor Apodaca said that property concerns him because of the graffiti, and it is an eye sore and maybe we can get public works to paint over it.

Manager Dr. Moore said that it is also housing the homeless and a fire hazard. Fire Chief Tabet agreed. Councilor Gordon asked if Dr. Moore was asking for these four properties to be demolished and \$100,000 to start. Manager Dr. Moore explained not to exceed \$100,000. Councilor Gutjahr stated this would give Dr. Moore permission to declare this as a nuisance and keep City Council informed. Manager Dr. Moore explained the second issue will be a budget adjustment resolution and would have to be approved to allow for that. Councilor Apodaca asked Councilors were going to vote on this at the City Council meeting tonight. Manager Dr. Moore said yes.

Memorandum of Understanding (MOU), NM Law Enforcement Telecommunications system, National Crime Information Center, NM Department of Public Safety and The City of Rio Communities Police Department (Manager/Police Chief/Council)

Police Chief Nunez explained the ORI number is an identification number for each department. It was issued by the FBI. This is a great place for us to move forward. These are not easy to get. It gives us the ability to run triple I's and get background checks on people. It controls the warrants and the local information center. Without this we wouldn't be able to enter missing people in a national database and continued the discussion.

Ordinance 2023 - XX Comcast Franchise Agreement 14-day review (Manager/Council)

Manager Dr. Moore said he appreciates the back and forth between our attorney's office and Comcast and our administration office here. We are looking at an ordinance and bringing it forward to the Council. Comcast stated that our portion has been going to the County. We let them know to continue to operate in our municipality they need to change it from County and send it to the city. Attorney Van Vleck said it is an Ordinance/agreement it is giving them permission to operate.

Public Comment:

No comments

Manager Report

Manager Dr. Moore said he will provide an update tonight at the meeting tonight about the missing person and he suggested a moment of silence for the missing person, the death of a former governor and of course 9/11. He further said on the speed bumps we found some that are 15-20 mph rated.

Council General Discussion & Future Agenda Items

Councilor Gutjahr said she got a complaint of drug dealings occurring in the Oasis Plaza.

Adjourn

The Regular Workshop was adjourned at 4:01 pm.

Respectfully submitted,

Lalena Aragon, Deputy Clerk

Date: _____

Approved:

Joshua Ramsell,
Mayor

Margaret R. Gutjahr,
Mayor Pro-tem/Councilor

Arthur Apodaca,
Councilor

Lawrence R. Gordon,
Councilor

Jimmie Winters,
Councilor

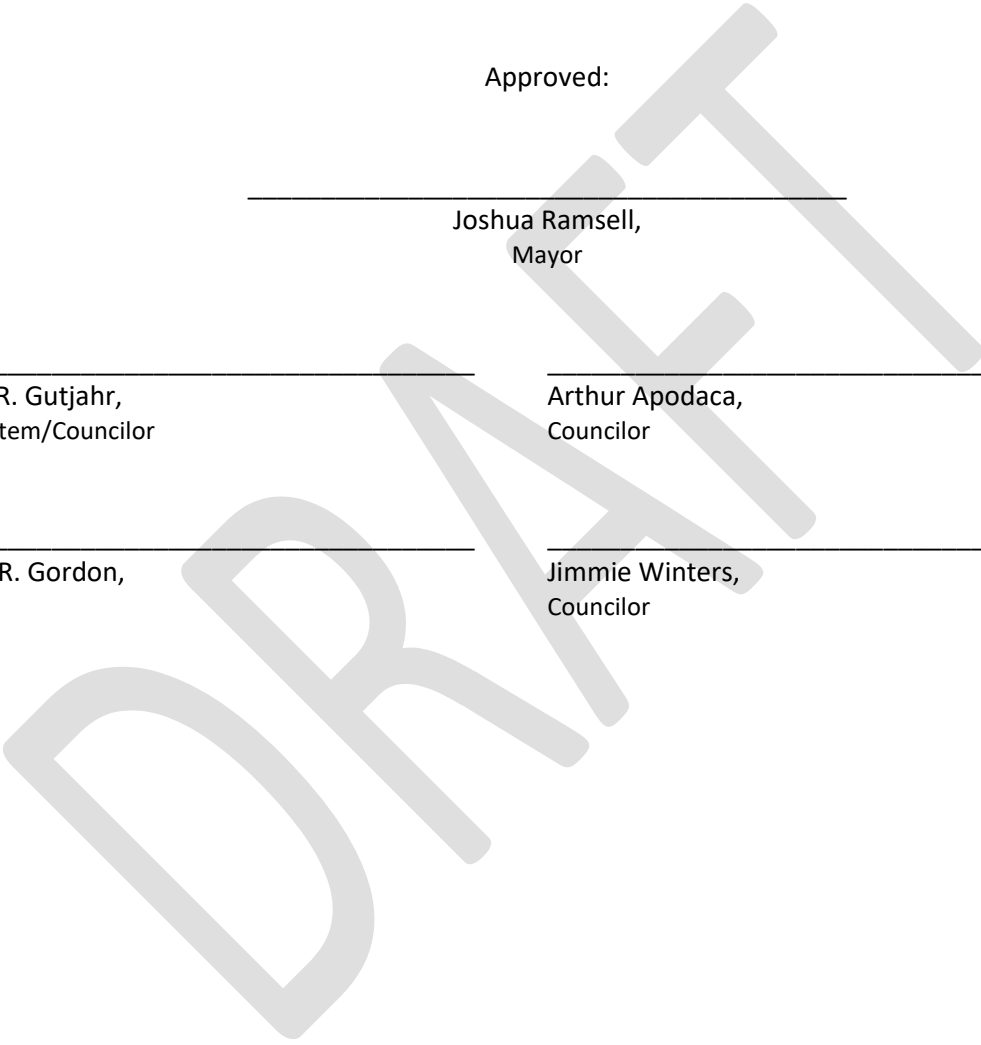



City of Rio Communities Council Regular Business Meeting
City Council Chambers - 360 Rio Communities Blvd
Rio Communities, NM 87002
Monday, September 11, 2023 6:00 PM
Minutes

Please silence all electronic devices.

Call to Order

Mayor Joshua Ramsell called the regular business meeting to order at 6:01 pm

Pledge of Allegiance

Councilor Gordon Led the Pledge of Allegiance

Moment of Silence for 9/11

Roll Call

PRESENT

Governing Body

Mayor Joshua Ramsell
Mayor Pro-Tem Margaret R. Gutjahr
Councilor Arthur Apodaca
Councilor Lawrence Gordon
Councilor Jimmie Winters

Staff

Manager Dr. Martin Moore
Clerk Elizabeth Adair
Finance Officer Stephanie Finch (virtual)
Accounting Specialist/CPO Angela Valadez
Fire Chief Andrew Tabet
Attorney Randall Van Vleck
Police Chief Felix Nunez

Approval of Agenda

Motion made by Councilor Apodaca to approve the agenda as written. Seconded by Councilor Winters.

Voting Yea:

Mayor Pro-Tem Gutjahr
Councilor Apodaca
Councilor Gordon
Councilor Winters

Motion passed with a 4-0 vote.

Approval of Consent Agenda Items Minutes for the City Council Workshop & Regular Business Meeting (08/28/23) & Accounts Payable

Motion made by Mayor Pro-Tem Gutjahr to approve the consent agenda. Seconded by Councilor Gordon.

Voting Yea:

Mayor Pro-Tem Gutjahr
Councilor Apodaca
Councilor Gordon
Councilor Winters

Motion passed with a 4-0 vote.

Presentation:

Valencia County Business Incubator - Ben Romero

Tabled

Public Hearing

Motion and roll call vote to recess Regular Business Meeting session and to go into Public Hearing

Motion made by Mayor Pro-Tem Gutjahr with a roll call vote to recess the regular business meeting session and go into the public hearing for consideration of Applicant Tasa Stromei requesting 05 N. Navajo Ave. to be rezoned from planned development to commercial 2. Motion seconded by Councilor Winters.

Voting Yea:

Mayor Pro-Tem Gutjahr
Councilor Apodaca
Councilor Gordon
Councilor Winters

With a 4-0 vote Council went into the public hearing at 6:07 pm.

Consideration of Applicant Tasa Stromei requesting 05 N. Navajo Ave. to be rezoned from planned development to commercial 2

Manager Dr. Moore said there is a memorandum in Council packet for reference from the Vice Chairman of the Planning and Zoning Commission. Recommendation of the Planning and Zoning Commission is that this property be rezoned to C2. There is a potential for future development in the area. Tasa Stromei stated that the property had been zoned C2 when it was in the County and when Rio Communities became a city it was then rezoned to planned development and we would just like it zoned back to C2.

Motion and roll call vote to go back into Regular Business Meeting session

Motion made by Councilor Apodaca with a roll call vote to go back into the regular business meeting session. Seconded by Councilor Gordon.

Voting Yea:

Mayor Pro-Tem Gutjahr
Councilor Apodaca
Councilor Gordon
Councilor Winters

With a 4-0 vote Council was back into the regular Business meeting session at 6:10 pm.

Discussion, Consideration, and Decision – Applicant Tasa Stromei requesting 05 N. Navajo Ave. to be rezoned from planned development to commercial 2

Motion made by Councilor Gordon to approve Stromei requesting 05 N. Navajo Ave. to be rezoned from planned development to commercial 2. Seconded by Councilor Winters.

Voting Yea:

- Mayor Pro-Tem Gutjahr
- Councilor Apodaca
- Councilor Gordon
- Councilor Winters

Motion passed with a 4-0 vote.

Public Hearing

Motion and roll call vote to recess Regular Business Meeting session and to go into Public Hearing Consideration of Ordinance 2023 - XX - Chapter 10 Local Economic Development Act (LEDA)

Motion made by Councilor Apodaca with a roll call vote to recess the regular business meeting session and go into the public hearing Consideration of Ordinance 2023 - XX - Chapter 10 Local Economic Development Act (LEDA). Seconded by Councilor Winters.

Voting Yea:

- Mayor Pro-Tem Gutjahr
- Councilor Apodaca
- Councilor Gordon
- Councilor Winters

With a 4-0 vote Council went into the public hearing at 6:12 pm.

Manager Dr. Moore said the purpose of this is to update our ordinance to mirror the updates in statue and take advantage of Local Economic tools. Ms. Jill Sweeney explained you have before you the policy level ordinance that is required by the local economic development act to be in place by the city prior to consideration to any project ordinance. This is a restatement and amendment of your existing ordinance. The primary purpose of the amendment is to add the opportunity to include both LEDA and gross receipt tax share which are statutory changes to make sure there are no conflicts.

Motion and roll call vote to go back into Regular Business Meeting session

Motion made by Councilor Apodaca to back into regular business meeting session. Seconded by Councilor Winters.

Voting Yea:

- Mayor Pro-Tem Gutjahr
- Councilor Apodaca
- Councilor Gordon
- Councilor Winters

With a 4-0 vote Council went back into the regular business meeting at 6:15 pm.

Discussion, Consideration, and Decision – Ordinance 2023 - 89 Chapter 10 Local Economic Development Act (LEDA)

Motion made by Mayor Pro-Tem Gutjahr to approve Ordinance 2023-89. Seconded by Councilor Winters.

Voting Yea:

- Mayor Pro-Tem Gutjahr
- Councilor Apodaca
- Councilor Gordon
- Councilor Winters

Motion passed with a 4-0 vote.

Public Hearing

Motion and roll call vote to recess Regular Business Meeting session and to go into Public Hearing Consideration of Ordinance 2023 - 90 Chapter 10 Industrial Revenue Bond Policy (IRB) and Local Economic Development Act (LEDA)

Motion made by Councilor Gordon. Seconded by Councilor Winters.

Voting Yea:

- Mayor Pro-Tem Gutjahr
- Councilor Apodaca
- Councilor Gordon
- Councilor Winters

With a 4-0 vote Council went into the public hearing at 6:18pm.

Manager Dr. Moore explained the industrial revenue bonds on occasion opportunities come to communities to discuss to rather or not enter an industrial revenue bond with a major developer on a manufacturing side. This is an opportunity to put another tool in the toolbox. Ms. Sweeney said this is a policy ordinance that lays out the processes through which the city would consider the IRB bonds and the LEDA projects they are two different tools, but the process is similar and further gave examples of LEDA and IRB that she previously discussed in a presentation. If a company wanting to relocate here that we are willing to partner with you and are ready to enter discussions with you but before we do that here is the information needed before we make a decision to enter into an IRB or LEDA ordinance.

Motion and roll call vote to go back into Regular Business Meeting session

Motion made by Councilor Apodaca. Seconded by Councilor Winters.

Voting Yea:

- Mayor Pro-Tem Gutjahr
- Councilor Apodaca
- Councilor Gordon
- Councilor Winters

With a 4-0 vote Council went back into regular business meeting at 6:24pm.

Discussion, Consideration, and Decision – Chapter 10 Industrial Revenue Bond Policy (IRB) and Local Economic Development Act (LEDA)

Motion made by Councilor Apodaca, Seconded by Councilor Gordon.

Voting Yea:

Mayor Pro-Tem Gutjahr
Councilor Apodaca
Councilor Gordon
Councilor Winters

With a 4-0 vote Resolution 2023 – 19 ICIP (Infrastructure Capital Improvement Plan) was passed, approved, adopted, and signed.

Public Comment:

No public comments.

Manager Report

- a) **Grant(s) update**
- b) **Zip Code update**
- c) **Municipal Court Department**

Manager Dr. Moore said there was a very brief municipal court update. There was a hand full of citations and no monies collected in the past month. He then said there was an outpour of support and help in the effort to search for the missing individual and it was very good to see people come together to help to find someone unfortunately it is an ongoing issue. Manager Dr. Moore said we are starting to get grant agreement documents on phase 2 for this building. Manager Dr. Moore further said that we have heard the concern for the speed bumps we are ordering for a different kind of speed bumps they will be wider and a little more gradual. Manager Dr. Moore stated on phase 1 of the building we will be going over a few things with our contractor and said the basic stuff have been cleared. Manager Dr. Moore gave some brief information on the 10th anniversary. Councilor Apodaca asked if we were going to test the new ones out and then replace them with the existing ones. Manager Dr. Moore said we are going to have test areas. He explained we do have some places that we have in the city that have high volumes of vehicular traffic. Councilor Gutjahr gave an update on the zip code update.

Discussion, Consideration, and Decision – Resolution 2023 - 21 Authorizing the Assignment of Authorized Officer(s) and Agent(s)

Manager Dr. Moore explained this is a resolution that is tied in to getting a grant agreement from the Department of Environment they have a different requirement we are asking that he be able to sign the agreement and the finance officer to sign as official representatives.

Motion made by Councilor Gorden to approve Resolution 2023 - 21 Authorizing the Assignment of Authorized Officer(s) and Agent(s). Seconded by Councilor Winters.

Voting Yea:

Mayor Pro-Tem Gutjahr
Councilor Apodaca
Councilor Gordon
Councilor Winters

With a 4-0 vote Resolution 2023 - XX Authorizing the Assignment of Authorized Officer(s) and Agent(s) was passed, approved, adopted and signed.

Discussion, Consideration, and Decision – Grant Agreement for Rio Communities 23-H2509-GF

Manager Dr. Moore said this is part 2 you just approved part 1. Part 2 is asking to approve the grant agreement on our side to move forward and execute for \$350,000 for storm water and drainage improvement.

Motion made by Councilor Apodaca to approve Grant Agreement for Rio Communities 23-H2509-GF. Seconded by Mayor Pro-Tem Gutjahr.

Voting Yea:

- Mayor Pro-Tem Gutjahr
- Councilor Apodaca
- Councilor Gordon
- Councilor Winters

With a 4-0 vote Council approved Grant Agreement for Rio Communities 23-H2509-GF.

Discussion, Consideration, and Decision – City Hall Parking Lot upgrades

Manager Dr. Moore said we are looking at our parking lot and there are cracks widening, the pavement is drying out and is several years old. We are talking to a company, Dessert Fox, LLC and we have 2 options. Option 1 is to seal the cracks then put a seal coat cost would be approximately \$4529.64 the second is sealing the cracks and going over with a half inch asphalt overlay with a tack coat that cost is \$16275.54. Option 1 is about 1-2 years and up to 10 years for option 2.

Manager Dr. Moore said he is recommending option 2 & 3 out of the quotation which would be \$10274.54 plus gross receipts tax. Councilor Apodaca said it is money well spent to extend the life of the parking lot for up to 10 years. Councilor Winters said he thinks it is the right choice if this is approved, we need notify our neighbors.

Motion made by Mayor Pro-Tem Gutjahr to approve the City Hall Parking Lot upgrades. Seconded by Councilor Gordon.

Voting Yea:

- Mayor Pro-Tem Gutjahr
- Councilor Apodaca
- Councilor Gordon
- Councilor Winters

With a 4-0 vote Council approved City Hall Parking lot upgrades.

Discussion, Consideration, and Decision – Authorizing Fund for Demolition & Cleanup of Dangerous & Nuisance Properties

Manager Dr. Moore said our City's Code Enforcement Officers have identified dangerous properties that have come in front of the City Council and then said we are asking for up to 100,000 to give us the ability to clean them up and then said we do have monies available in available cash for that.

The concerns have been heard by citizens and the return would be the clean up of the properties. Councilor Apodaca said I think it is money well spent.

Councilor Gutjahr said I think so to people coming into the city they can see how up to date and clean it is it is important for economic development and people coming in.

Councilor Gordon said I agree it is a mark of improvement for the people coming into town.

Councilor Winters said I think every economic development expert we have brought in here has said to clean the place up.

Motion made by Councilor Apodaca to Authorizing Fund for Demolition & Cleanup of Dangerous & Nuisance Properties not to exceed \$100,00.00. Seconded by Councilor Winters.

Voting Yea:

Mayor Pro-Tem Gutjahr

Councilor Apodaca With a 4-0 vote Council approved Authorizing Fund for
Councilor Gordon for Demolition & Cleanup of Dangerous &
Councilor Winters Nuisance Properties not to exceed \$100,00.00.

Discussion, Consideration, and Decision – Memorandum of Understanding (MOU), NM Law Enforcement Telecommunications system, National Crime Information Center, NM Department of Public Safety and The City of Rio Communities Police Department

Manager Dr. Moore explained the City has a ORI number and that is authorized by the FBI and the next step is to get authorized by NCIC. Police Chief Nunez stated earlier this is a great milestone for the city to have this is a control number running with a fulltime police department. We can do a lot of great things and stay up with the times of policing and public safety.

Motion made by Councilor Apodaca Memorandum of Understanding (MOU), NM Law Enforcement Telecommunications system, National Crime Information Center, NM Department of Public Safety and The City of Rio Communities Police Department. Seconded by Councilor Winters.

Voting Yea:

Mayor Pro-Tem Gutjahr

Councilor Apodaca With a 4-0 vote Council approved the Memorandum of
Councilor Gordon Understanding (MOU), NM Law Enforcement
Councilor Winters Telecommunications system, National Crime
 Information Center, NM Department of Public Safety and The City
 of Rio Communities Police Department.

Discussion, Consideration, and Decision – Ordinance 2023 - XX Comcast Franchise Agreement 14-day review

Manager Dr. Moore said the City of Rio Communities being an incorporated by state law utilities that operate, and Comcast qualifies as a utility under the State of New Mexico statue they are required to enter a franchise agreement with the City. They have been going through the County and we need to go directly though the City and not the County. Councilor Apodaca said I am glad to see this move forward and we will benefit from this instead of the county. Councilor Gutjahr said we have wanted this for a long time. Councilor Gordon thanked Dr. Moore for getting this done. Mayor Ramsell said this has been a work in progress I am glad we are at this point. Manager Dr. Moore said thanks to our City Attorney and staff to help this to progress.

Motion made by Councilor Apodaca Ordinance 2023 - XX Comcast Franchise Agreement 14-day review. Seconded by Councilor Winters.

Voting Yea:

Mayor Pro-Tem Gutjahr

Councilor Apodaca

Councilor Gordon

Councilor Winters

With a 4-0 vote Council approved the 14-day review of Ordinance 2023 – XX Comcast Franchise Agreement 14-day review.

Council Discussion

No comments.

Executive Session - For the purpose of an Improvement Plan for the Municipal Clerk pursuant to NMSA 10-15-1(H)(2) - Limited Personnel Matters and the discussion of the purchase, addition or disposal of real property or water rights by the public body pursuant to NMSA 10-15-1(H)(8)

Motion and roll call vote to go into close session

Motion made by Mayor Pro-Tem Gutjahr to go into closed session. Seconded by Councilor Winters.

Voting Yea:

Mayor Pro-Tem Gutjahr

Councilor Apodaca

Councilor Gordon

Councilor Winters

With a 4-0 vote Council went into executive session at 6:57 pm.

Welcome everyone back and statement by the Mayor

See agenda for Statement.

Motion and roll call vote to go back into the regular business meeting session

Motion made by Councilor Apodaca with a roll call vote to go back into the regular business meeting session. Seconded by Councilor Winters.

Voting Yea:

Mayor Pro-Tem Gutjahr

Councilor Apodaca

Councilor Gordon

Councilor Winters

With a 4-0 vote Council went back into the regular business meeting session at 8:00 pm.

Recommendation, Discussion, Consideration, and Decision - For the purpose of an Improvement Plan for the Municipal Clerk pursuant to NMSA 10-15-1(H)(2) - Limited Personnel Matters and the discussion of the purchase, addition or disposal of real property or water rights by the public body pursuant to NMSA 10-15-1(H)(8)

Mayor Ramsell said there are no recommendations at this time.

Adjourn

Motion made by Councilor Winters to adjourn. Seconded by Councilor Gordon. With a unanimous vote the regular business meeting session was adjourned at 8:02pm.

Respectfully submitted,

Lalena Aragon, Deputy Clerk

Date: _____

Approved:

Joshua Ramsell,
Mayor

Margaret R. Gutjahr,
Mayor Pro-tem/Councilor

Arthur Apodaca,
Councilor

Lawrence R. Gordon,
Councilor

Jimmie Winters,
Councilor



By Check Number

Vendor Number	Vendor Name	Payment Date	Payment Type	Discount Amount	Payment Amount	Number
Bank Code: AP BANK CODE-AP BANK CODE						
VEN04203	Artesia Fire Equipment Inc.	09/21/2023	Regular	0.00	11,515.60	4273
VEN04222	Boundtree Medical	09/21/2023	Regular	0.00	19,517.52	4274
VEN04231	Century Link	09/21/2023	Regular	0.00	77.71	4275
VEN04286	Elizabeth F. Adair	09/21/2023	Regular	0.00	429.72	4276
VEN04311	Garcia & Sons Security	09/21/2023	Regular	0.00	357.44	4277
VEN04518	Santa Fe New Mexican	09/21/2023	Regular	0.00	404.62	4278
VEN04562	TLC Plumbing & Utility Commercial S	09/21/2023	Regular	0.00	14,933.76	4279
VEN04573	Universal Waste Systems, Inc.	09/21/2023	Regular	0.00	1,297.12	4280
VEN04582	Valencia County Fiscal Office	09/21/2023	Regular	0.00	1,469.60	4281
VEN04598	Wells Fargo Financial Leasing	09/21/2023	Regular	0.00	2,497.73	4282
VEN04603	Woodlands Hardware	09/21/2023	Regular	0.00	217.61	4283
VEN04185	Amazon Business	09/21/2023	EFT	0.00	600.99	100662
VEN04776	Andrew J Good	09/21/2023	EFT	0.00	6,271.30	100663
VEN04774	Greg Gallegos	09/21/2023	EFT	0.00	175.50	100664
VEN04696	Griffin & Associates Marketing, Inc.	09/21/2023	EFT	0.00	2,039.31	100665
VEN04726	H&E Equipment	09/21/2023	EFT	0.00	162.09	100666
VEN04620	HDR Engineering, Inc.	09/21/2023	EFT	0.00	53,069.41	100667
VEN04781	Kaylee Dons	09/21/2023	EFT	0.00	175.50	100668
VEN04709	Maloy Mobile Storage Inc.	09/21/2023	EFT	0.00	487.36	100669
VEN04847	Matthew Lewis	09/21/2023	EFT	0.00	175.50	100670
VEN04806	McKesson Medical-Surgical Governn	09/21/2023	EFT	0.00	502.05	100671
VEN04684	Palmetto LLC	09/21/2023	EFT	0.00	1,894.30	100672
VEN04835	PharmaLink, INC.	09/21/2023	EFT	0.00	150.00	100673
VEN04477	Rentokil North America Inc.	09/21/2023	EFT	0.00	453.54	100674
VEN04527	Sharp Electronics Corporation	09/21/2023	EFT	0.00	653.65	100675
VEN04538	Staples Contract & Commercial, LLC.	09/21/2023	EFT	0.00	192.70	100676
VEN04838	Tovuti, Inc.	09/21/2023	EFT	0.00	5,188.00	100677
VEN04663	UniqueFleet, LLC.	09/21/2023	EFT	0.00	5,909.54	100678
VEN04249	Comcast Business	09/26/2023	Bank Draft	0.00	281.27	DFT0000928

Bank Code AP BANK CODE Summary

Payment Type	Payable Count	Payment Count	Discount	Payment
Regular Checks	21	11	0.00	52,718.43
Manual Checks	0	0	0.00	0.00
Voided Checks	0	0	0.00	0.00
Bank Drafts	1	1	0.00	281.27
EFT's	31	17	0.00	78,100.74
	53	29	0.00	131,100.44

Fund Summary

Fund	Name	Period	Amount
99000	Pooled Cash Fund	9/2023	131,100.44
			<hr/> 131,100.44

Authorization Signatures

CHECK REGISTER

This check register has been reviewed and verified for accuracy.

First Signor

Date

Second Signor



Accounts Payable Approval Report By Fund

Vendor Name	Payable Number	Post Date	Description (Item)	Amount
Fund: 11000 - General Operating Fund				
Department: 1009 - Municipal Court				
Amazon Business	1VGL-GRQ6-D6TJ	09/13/2023	office supplies	290.91
Amazon Business	1VGL-GRQ6-D6TJ	09/13/2023	3 count filing cabinets	310.08
Department 1009 - Municipal Court Total:				600.99
Department: 2002 - General Administration				
Wells Fargo Financial Leasing	5026594076	09/12/2023	CH Server Lease - Contract #8...	2,497.73
Rentokil North America Inc.	51299414	09/13/2023	City Hall - Pest Control	180.58
Santa Fe New Mexican	91661	09/19/2023	Invitation to bid	202.96
Santa Fe New Mexican	91670	09/19/2023	Invitation to bid	201.66
Garcia & Sons Security	0458	09/21/2023	Rekey Doors @ CH & Safe Co...	357.44
Sharp Electronics Corporation	5026710249	09/21/2023	Contract#800493854- MX3071..	276.02
Tovuti, Inc.	IN6625	09/21/2023	Employee Training Software	5,188.00
Department 2002 - General Administration Total:				8,904.39
Department: 2004 - Finance/Budget/Accounting				
Staples Contract & Commercia...	8071573972	09/13/2023	Finance Office Supplies	100.30
Sharp Electronics Corporation	SH586032	09/21/2023	Finance Department Copies	187.21
Department 2004 - Finance/Budget/Accounting Total:				287.51
Department: 2008 - Municipal Clerk				
Elizabeth F. Adair	INV0004372	09/11/2023	66th Annual Conference Farm...	429.72
Staples Contract & Commercia...	8071540695	09/13/2023	various office supplies	92.40
Department 2008 - Municipal Clerk Total:				522.12
Department: 3001 - Law Enforcement				
Sharp Electronics Corporation	SH586033	09/21/2023	Police Dept. Copies	165.17
Department 3001 - Law Enforcement Total:				165.17
Department: 3004 - Animal Control				
Valencia County Fiscal Office	AC2024-11	09/13/2023	Animal Control	1,469.60
Department 3004 - Animal Control Total:				1,469.60
Department: 5101 - Public Works				
Woodlands Hardware	011419/1	09/12/2023	Various Supplies	19.44
Maloy Mobile Storage Inc.	0318448-IN	09/12/2023	40' Storage Container Serial#8...	243.68
Maloy Mobile Storage Inc.	0318531-IN	09/12/2023	40' Storage Container Serial#8...	243.68
H&E Equipment	97571131	09/12/2023	Street Sweeper 1 Week Rental...	162.09
Woodlands Hardware	011459/1	09/13/2023	Various Supplies	8.00
Woodlands Hardware	011476/1	09/13/2023	Various Supplies	47.75
Woodlands Hardware	011441/1	09/21/2023	Various Supplies	36.84
Department 5101 - Public Works Total:				761.48
Fund 11000 - General Operating Fund Total:				12,711.26
Fund: 20200 - Environmental				
Department: 5009 - Environmental				
Universal Waste Systems, Inc.	0002425356	09/13/2023	Clean Up day-Dumpsters	1,297.12
Department 5009 - Environmental Total:				1,297.12
Fund 20200 - Environmental Total:				1,297.12
Fund: 20900 - Fire Protection				
Department: 3002 - Fire Protection				
Woodlands Hardware	0111428/1	09/12/2023	Various Supplies	56.99
Rentokil North America Inc.	51299567	09/12/2023	Fire Dept. - Pest Control	144.04
Rentokil North America Inc.	51299688	09/12/2023	Fire Dept. - Pest Control	128.92
Boundtree Medical	85085980	09/12/2023	AED Defibrillators	10,799.91
Woodlands Hardware	011478.1	09/13/2023	Various Supplies	21.16
UniqueFleet, LLC.	22142	09/13/2023	Preventative Maint on Fire Ve...	578.96

Accounts Payable Approval Report

Vendor Name	Payable Number	Post Date	Description (Item)	Amount
UniqueFleet, LLC.	22172	09/13/2023	Preventative Maint on Fire Ve...	769.91
UniqueFleet, LLC.	22211	09/13/2023	Preventative Maint on Fire Ve...	4,560.67
Sharp Electronics Corporation	5026594075	09/13/2023	Fire Dept Copier Lease - Cont...	25.25
Century Link	INV0004374	09/13/2023	FD/Substation - Telephone ser...	77.71
Woodlands Hardware	011486/1	09/19/2023	Various Supplies	27.43
McKesson Medical-Surgical G...	20922081	09/19/2023	MED supplies	227.00
McKesson Medical-Surgical G...	21032284	09/19/2023	MED supplies	80.92
McKesson Medical-Surgical G...	21110984	09/19/2023	MED supplies	194.13
TLC Plumbing & Utility Comme..	CH543527-1	09/21/2023	new 4 ton AC	14,933.76
Comcast Business	INV0004373	09/26/2023	Fire Dept. Telecommunications	281.27
Department 3002 - Fire Protection Total:				32,908.03
Fund 20900 - Fire Protection Total:				32,908.03
Fund: 26000 - American Rescue Plan Act				
Department: 2002 - General Administration				
Artesia Fire Equipment Inc.	81203	09/12/2023	DQE-HM6000 DQE Decon in a...	11,515.60
Department 2002 - General Administration Total:				11,515.60
Fund 26000 - American Rescue Plan Act Total:				11,515.60
Fund: 29700 - County EMS GRT				
Department: 2002 - General Administration				
Boundtree Medical	85089270	09/13/2023	Medical Supplies	1,437.30
PharmaLink, INC.	794584	09/19/2023	Expired medication disposal	150.00
Boundtree Medical	85095286	09/20/2023	Medical Supplies	42.81
Boundtree Medical	85096755	09/21/2023	Medical Supplies	37.56
Department 2002 - General Administration Total:				1,667.67
Fund 29700 - County EMS GRT Total:				1,667.67
Fund: 29800 - Wildland Fire				
Department: 2002 - General Administration				
Kaylee Dons	INV0004375	09/21/2023	ABO Springs Fire	175.50
Matthew Lewis	INV0004376	09/21/2023	ABO Springs Fire	175.50
Greg Gallegos	INV0004377	09/21/2023	ABO Springs Fire	175.50
Andrew J Good	INV0004378	09/21/2023	Deployed w/Bernalillo County...	6,271.30
Department 2002 - General Administration Total:				6,797.80
Fund 29800 - Wildland Fire Total:				6,797.80
Fund: 30400 - Road/Street Projects				
Department: 2002 - General Administration				
HDR Engineering, Inc.	1200555178 A	09/13/2023	NM GRT (7.625%)	161.83
HDR Engineering, Inc.	1200555178 A	09/13/2023	Task 1- Project Management	1,309.50
HDR Engineering, Inc.	1200555181	09/13/2023	Task 3 - Preliminary & Final De...	46,720.75
HDR Engineering, Inc.	1200555181	09/13/2023	GRT (7.7500%)	3,562.46
Department 2002 - General Administration Total:				51,754.54
Fund 30400 - Road/Street Projects Total:				51,754.54
Fund: 39900 - Other Capital Projects				
Department: 2002 - General Administration				
Boundtree Medical	85085980	09/12/2023	AED Defribillators	7,199.94
Griffin & Associates Marketing...	001245	09/13/2023	Independent Contractor Agre...	2,039.31
HDR Engineering, Inc.	1200555153	09/13/2023	On-Call Engineering Services	502.07
HDR Engineering, Inc.	1200555178 B	09/13/2023	Task 4 Bid Phase Services	812.80
Palmetto LLC	16	09/13/2023	Economic Development Consu...	1,894.30
Department 2002 - General Administration Total:				12,448.42
Fund 39900 - Other Capital Projects Total:				12,448.42
Grand Total:				131,100.44

Fund Summary

Fund	Expense Amount
11000 - General Operating Fund	12,711.26
20200 - Environmental	1,297.12
20900 - Fire Protection	32,908.03
26000 - American Rescue Plan Act	11,515.60
29700 - County EMS GRT	1,667.67
29800 - Wildland Fire	6,797.80
30400 - Road/Street Projects	51,754.54
39900 - Other Capital Projects	12,448.42
Grand Total:	131,100.44

Account Summary

Account Number	Account Name	Expense Amount
11000-1009-56020	Supplies - General Office	290.91
11000-1009-56040	Supplies-Furniture/Fixtu...	310.08
11000-2002-55030	Contract - Professional S...	180.58
11000-2002-55999	Contract - Other Services	357.44
11000-2002-56010	Software	5,188.00
11000-2002-57090	Printing/Publishing/Adve...	404.62
11000-2002-57130	Rent of Equipment/Mach..	2,773.75
11000-2004-56020	Supplies - General Office	100.30
11000-2004-57090	Printing/Publishing/Adve...	187.21
11000-2008-53030	Travel - Employees	429.72
11000-2008-56020	Supplies - General Office	92.40
11000-3001-57090	Printing/Publishing/Adve...	165.17
11000-3004-55999	Contract - Other Services	1,469.60
11000-5101-55999	Contract - Other Services	487.36
11000-5101-56030	Supplies - Field Supplies	112.03
11000-5101-57130	Rent of Equipment/Mach..	162.09
20200-5009-55999	Contract - Other Services	1,297.12
20900-3002-54040	Maintenance & Repairs -...	5,909.54
20900-3002-55030	Contract - Professional S...	272.96
20900-3002-56030	Supplies - Field Supplies	105.58
20900-3002-56040	Supplies-Furniture/Fixtu...	25,733.67
20900-3002-56070	Supplies - Medical	502.05
20900-3002-57130	Rent of Equipment/Mach..	25.25
20900-3002-57160	Telecommunications	358.98
26000-2002-58020	Equipment & Machinery	11,515.60
29700-2002-55999	Contract - Other Services	150.00
29700-2002-56070	Supplies - Medical	1,517.67
29800-2002-51050	Salaries - Temporary Pos...	6,797.80
30400-2002-55030	Contract - Professional S...	51,754.54
39900-2002-55030	Contract - Professional S...	5,248.48
39900-2002-56040	Supplies-Furniture/Fixtu...	7,199.94
Grand Total:		131,100.44

Project Account Summary

Project Account Key	Expense Amount
None	79,345.90
2021-040-002-50000	1,471.33
D19427-50000	50,283.21
Grand Total:	131,100.44

MAYOR & COUNCILORS

JOSHUA RAMSELL, MAYOR

MARGARET "PEGGY" GUTJAHR, MAYOR PRO-TEM

LAWRENCE GORDON, COUNCILOR

ARTHUR APODACA, COUNCILOR

JIM WINTERS, COUNCILOR

ATTEST:

ORDINANCE No. 2023-XX

**AN ORDINANCE GRANTING CERTAIN RIGHTS AND PRIVILEGES TO
COMCAST OF NEW MEXICO, LLC, ITS SUCCESSORS AND ASSIGNS**

**BE IT ORDAINED by the Governing Body of the City of Rio Communities, State of
New Mexico**

The City of Rio Communities, having determined that the financial, legal, and technical ability of the Grantee is reasonably sufficient to provide the services, facilities, and equipment necessary to meet the future cable-related needs of the community, desires to enter into this non-exclusive Franchise Agreement with the Grantee for the construction, operation and maintenance of a Cable System on the terms and conditions set forth herein.

SECTION 1 - Definition of Terms

For the purpose of this Franchise Agreement, capitalized terms, phrases, words, and abbreviations shall have the meanings given herein. When not inconsistent with the context, words used in the present tense include the future, words in the plural include the singular, and words in the singular include the plural. Words not defined shall be given their common and ordinary meaning. The word "shall" is always mandatory and not merely directory.

1.1.1 "Affiliate" when used in connection with Grantee, means any Person who owns or controls, is owned or controlled by, or is under common ownership or control with, Grantee.

1.1. "Cable Service" shall mean (A) the one-way transmission to subscribers of (i) video programming, or (ii) other programming service, and (B) subscriber interaction, if any, which is required for the selection or use of such video programming or other programming service.

1.2. "Cable System" shall mean a facility, consisting of a set of closed transmission paths and associated signal generation, reception, and control equipment that is designed to provide cable service which includes video programming and which is provided to multiple subscribers within a community, but such term does not include (A) a facility that serves only to retransmit the televisions signals of one or more television broadcast stations, (B) a facility that serves subscribers without using any public right of way; (C) a facility of a common carrier which is subject, in whole or in part, to the provisions of Title II of the federal Communications Act (47 U.S.C. § 201 et seq.), except that such facility shall be considered a Cable System (other than for purposes of Section 621(c) (47 U.S.C. 541(c)) to the extent such facility is used in the transmission of video programming directly to Subscribers, unless the extent of such use is solely to provide interactive on-demand services; (D) an open video system that complies with federal

statutes; or (E) any facilities of any electric utility used solely for operating its electric utility systems.

1.3. “Customer” means a Person or user of the Cable System who lawfully receives Cable Service therefrom with the Grantee’s express permission.

1.4. “Effective Date” means the date on which all persons necessary to sign this Agreement in order for it to be binding on both parties have executed this Agreement as indicated on the signature page(s), unless a specific date is otherwise provided in the “Term” section herein.

1.5. “FCC” means the Federal Communications Commission, or successor governmental entity thereto.

1.6. “Franchise” means the initial authorization, or renewal thereof, issued by the Franchising Authority, whether such authorization is designated as a franchise, agreement, permit, license, resolution, contract, certificate, ordinance or otherwise, which authorizes the construction and operation of the Cable System.

1.7. “Franchise Agreement” or “Agreement” shall mean this Agreement and any amendments or modifications hereto.

1.8. “Franchise Area” means the present legal boundaries of the City of Rio Communities as of the Effective Date, and shall also include any additions thereto, by annexation or other legal means.

1.9. “Franchising Authority” means the City of Rio Communities, New Mexico or the lawful successor, transferee, designee, or assignee thereof.

1.10. “Grantee” shall mean Comcast of New Mexico, LLC.

1.11. “Gross Revenue” means and shall be construed broadly to include any and all cash, credits or other consideration of any kind or nature in any way derived from the operation of the Grantee’s Cable System to provide Cable Services in the Franchising Authority, received directly or indirectly by a Grantee, calculated in accordance with generally accepted accounting principles.

A. Gross Revenues shall include, but is not limited to:

1. monthly fees charged subscribers, regardless of whether such Cable Services are provided to residential or commercial customers, for any basic, optional, premium or pay-per-view service.

2. installation, disconnection, reconnection, and change-in-service fees associated with changes in subscriber Cable Service levels.

3. fees paid to Grantee for channels designated for commercial/leased access use and shall be allocated on a pro rata basis using total Cable Service subscribers within the City.

4. revenues from converter rentals or sales.
5. advertising revenues which shall include revenues derived from sales of advertising that are made available to Grantee's Cable System subscribers within the City of Rio Communities and shall be allocated on a pro rata basis using total Cable Service subscribers reached by the advertising. Additionally, Grantee agrees that Gross Revenues subject to franchise fees shall include all commissions, rep fees, Affiliated Entity fees, or rebates paid to National Cable Communications ("NCC") and Comcast effectv or their successors associated with sales of advertising on the Cable System within the City of Rio Communities allocated according to this paragraph using total Cable Service subscribers reached by the advertising;
6. barter.
7. revenues from program guides; and revenues from home shopping services.
8. Franchise Fees.
9. FCC Regulatory Fees.

Gross Revenues shall be the basis for computing the Grantee's Franchise Fee under this Agreement.

B. Gross Revenues shall not include

1. actual bad debt write-offs, except any portion which is subsequently collected which shall be allocated on a pro rata basis using Cable Services revenue as a percentage of total subscriber revenues within the City.
2. any taxes and/or fees on services furnished by Grantee imposed by any municipality, state, or other governmental unit, provided that Franchise Fees and the FCC regulatory fee shall not be regarded as such a tax or fee.
3. fees imposed by any municipality, state, or other governmental unit on Grantee including but not limited to Public, Educational, and Governmental (PEG) Fees.
4. launch fees and marketing co-op fees; and,
5. unaffiliated, third-party, advertising sales agency fees that are reflected as a deduction from revenues.

1.12. "Person" means any natural person or any association, firm, partnership, joint venture, corporation, or other legally recognized entity, whether for-profit or not-for profit, but shall not mean the Franchising Authority.

1.13. "Public Way" shall mean the surface of, and the space above and below, any public street, highway, freeway, bridge, land path, alley, court, boulevard, sidewalk, way, lane, public way, drive, circle or other public right-of-way, including, but not limited to, public utility easements, dedicated utility strips, or easements dedicated for compatible uses and any temporary or permanent fixtures or improvements located thereon now or hereafter held by the Franchising Authority in the Franchise Area, which shall entitle the Franchising Authority and the Grantee to the use thereof for the purpose of installing, operating, repairing, and maintaining the Cable System. Public Way shall also mean any easement now or hereafter held by the Franchising Authority within the Franchise Area for

the purpose of public travel, or for utility or public service use dedicated for compatible uses, and shall include other easements or rights-of-way as shall within their proper use and meaning entitle the Franchising Authority and the Grantee to the use thereof for the purposes of installing, operating, and maintaining the Grantee's Cable System over poles, wires, cables, conductors, ducts, conduits, vaults, manholes, amplifiers, appliances, attachments, and other property as may be ordinarily necessary and pertinent to the Cable System.

SECTION 2 - Grant of Authority

2.1. The Franchising Authority hereby grants to the Grantee a nonexclusive Franchise authorizing the Grantee to construct and operate a Cable System in the Public Ways within the Franchise Area, and for that purpose to erect, install, construct, repair, replace, reconstruct, maintain, or retain in any Public Way such poles, wires, cables, conductors, ducts, conduits, vaults, manholes, pedestals, amplifiers, appliances, attachments, and other related property or equipment as may be necessary or appurtenant to the Cable System, and to provide such services over the Cable System as may be lawfully allowed.

2.1.1 Subject to federal and state preemption, the provisions of this Franchise constitute a valid and enforceable contract between the parties. The material terms and conditions contained in this Franchise may not be unilaterally altered by the Franchising Authority through subsequent amendment to any ordinance, rule, regulation, or other enactment of the Franchising Authority, except in the lawful exercise of the Franchising Authority's police power.

2.1.2 Notwithstanding any other provision of this Franchise, Grantee reserves the right to challenge provisions of any ordinance, rule, regulation, or other enactment of the Franchising Authority that conflicts with its contractual rights under this Franchise, either now or in the future.

2.1.3 This Franchise shall not be interpreted to prevent the City from imposing additional lawful conditions, including additional compensation conditions for use of the Rights-of-Way only as permitted by Applicable Law should Grantee provide service other than Cable Service.

2.14 Grantee promises and guarantees, as a condition of exercising the privileges granted by this Franchise, that any Affiliate of the Grantee directly involved in the offering of Cable Service in the Franchise Area, or directly involved in the management or operation of the Cable System in the Franchise Area, will also comply with the obligations of this Franchise.

2.15 No rights shall pass to Grantee by implication. Without limiting the foregoing, by way of example and not limitation, this Franchise shall not include or be a substitute for:

(1) Any other permit or authorization required for the privilege of transacting and carrying on a business within the City that may be required by the ordinances and laws of the City;

(2) Any permit, agreement, or authorization required by the City for Right-of-Way users in connection with operations on or in Rights-of-Way or public property including, by way of example and not limitation, street cut permits; or

(3) Any permits or agreements for occupying any other property of the City or private entities to which access is not specifically granted by this Franchise including, without limitation, permits and agreements for placing devices on poles, in conduits or in or on other structures.

2.16 This Franchise is intended to convey limited rights and interests only as to those Rights-of-Way in which the City has an actual interest. It is not a warranty of title or interest in any Right-of-Way; it does not provide the Grantee with any interest in any particular location within the Right-of-Way; and it does not confer rights other than as expressly provided in the grant hereof.

2.2. Term of Franchise. The term of the Franchise granted hereunder shall be ten (10) years, commencing upon the Effective Date of the Franchise, unless the Franchise is renewed or is lawfully terminated in accordance with the terms of this Franchise Agreement and the Cable Act, or is extended by mutual agreement of the Franchising Authority and Grantee.

2.3. Renewal. Any renewal of this Franchise shall be governed by and comply with the provisions of Section 626 of the Cable Act, as amended.

Should the Franchise expire without a mutually agreed upon renewed Franchise Agreement and Grantee and Franchising Authority are engaged in an informal or formal renewal process, the Franchise shall continue on a month-to-month basis, with the same terms and conditions as provided in the Franchise, and the Grantee and Franchising Authority shall continue to comply with all obligations and duties under the Franchise.

2.4. Reservation of Authority. Nothing in this Franchise Agreement shall (A) abrogate the right of the Franchising Authority to perform any public works or public improvements of any description, (B) be construed as a waiver of any codes or ordinances of general applicability promulgated by the Franchising Authority, or (C) be construed as a waiver or release of the rights of the Franchising Authority in and to the Public Ways.

SECTION 3 – Construction and Maintenance of the Cable System

3.1. Permits and General Obligations. The Grantee shall be responsible for obtaining, at its own cost and expense, all generally applicable permits, licenses, or other forms of approval or authorization necessary to construct, operate, maintain or repair the

Cable System, or any part thereof, prior to the commencement of any such activity. Construction, installation, and maintenance of the Cable System shall be performed in a safe, thorough and reliable manner using materials of good and durable quality. All transmission and distribution structures, poles, other lines, and equipment installed by the Grantee for use in the Cable System in accordance with the terms and conditions of this Franchise Agreement shall be located so as to minimize the interference with the proper use of the Public Ways and the rights and reasonable convenience of property owners who own property that adjoins any such Public Way.

3.2. Conditions of Street Occupancy.

3.2.1. New Grades or Lines. If the grades or lines of any Public Way within the Franchise Area are lawfully changed at any time during the term of this Franchise Agreement, then the Grantee shall, upon reasonable advance written notice from the Franchising Authority (which shall not be less than ten (10) business days) and at its own cost and expense, protect or promptly alter or relocate the Cable System, or any part thereof, so as to conform with any such new grades or lines. If public funds are available to any other user of the Public Way for the purpose of defraying the cost of any of the foregoing, the Franchising Authority shall notify Grantee of such funding and make available such funds to the Grantee.

3.2.2. Relocation at request of Third Party. The Grantee shall, upon reasonable prior written request of any Person holding a permit issued by the Franchising Authority to move any structure, temporarily move its wires to permit the moving of such structure; provided (i) the Grantee may impose a reasonable charge on any Person for the movement of its wires, and such charge may be required to be paid in advance of the movement of its wires; and (ii) the Grantee is given not less than ten (10) business days advance written notice to arrange for such temporary relocation.

3.2.3. Restoration of Public Ways. If in connection with the construction, operation, maintenance, or repair of the Cable System, the Grantee disturbs, alters, or damages any Public Way, the Grantee agrees that it shall at its own cost and expense replace and restore any such Public Way to a condition reasonably comparable to the condition of the Public Way existing immediately prior to the disturbance.

3.2.4. Safety Requirements. The Grantee shall, at its own cost and expense, undertake all necessary and appropriate efforts to maintain its work sites in a safe manner in order to prevent failures and accidents that may cause damage, injuries or nuisances. All work undertaken on the Cable System shall be performed in substantial accordance with applicable FCC or other federal and state regulations. The Cable System shall not unreasonably endanger or interfere with the safety of Persons or property in the Franchise Area.

3.2.5. Trimming of Trees and Shrubbery. The Grantee shall have the authority to trim trees or other natural growth overhanging any of its Cable System in the Franchise Area so as to prevent contact with the Grantee's wires, cables, or other

equipment. All such trimming shall be done at the Grantee's sole cost and expense. The Grantee shall be responsible for any damage caused by such trimming.

3.2.6. Aerial and Underground Construction. At the time of Cable System construction, if all of the transmission and distribution facilities of all of the respective public or municipal utilities in any area of the Franchise Area are underground, the Grantee shall place its Cable Systems' transmission and distribution facilities underground, provided that such underground locations are actually capable of accommodating the Grantee's cable and other equipment without technical degradation of the Cable System's signal quality. In any region(s) of the Franchise Area where the transmission or distribution facilities of the respective public or municipal utilities are both aerial and underground, the Grantee shall have the discretion to construct, operate, and maintain all of its transmission and distribution facilities, or any part thereof, aerially or underground. Nothing in this Section shall be construed to require the Grantee to construct, operate, or maintain underground any ground-mounted appurtenances such as customer taps, line extenders, system passive devices, amplifiers, power supplies, pedestals, or other related equipment.

3.2.7. Undergrounding and Beautification Projects. In the event all users of the Public Way relocate aerial facilities underground as part of an undergrounding or neighborhood beautification project, Grantee shall participate in the planning for relocation of its aerial facilities contemporaneously with other utilities. Grantee's relocation costs shall be included in any computation of necessary project funding by the municipality or private parties. Grantee shall be entitled to reimbursement of its relocation costs from public or private funds raised for the project and made available to other users of the Public Way.

3.2.8 The Grantee in the construction and operation of the system shall perform its work in such manner as to create the least inconvenience to the inhabitants of the City and the public generally, and shall repair, at Grantee's expense, all damage to public or private property resulting from its use.

3.3 Use of Rights-of-Way.

- (A) Subject to the City's supervision and control, Grantee may erect, install, construct, repair, replace, reconstruct, and retain in, on, over, under, upon, across, and along the Rights-of-Way within the City such wires, cables, conductors, ducts, conduits, vaults, manholes, amplifiers, pedestals, attachments, and other property and equipment as are necessary and appurtenant to the operation of a Cable System within the City. Grantee, through this Franchise, is granted extensive and valuable rights to operate its Cable System for profit using the City's Rights-of-Way in compliance with all applicable City construction codes and procedures. As trustee for the public, the City is entitled to fair compensation as provided for in Section 7 of this Franchise to be paid for these valuable rights throughout the term of the Franchise.

- (B) Grantee must follow City established nondiscriminatory requirements for placement of Cable System facilities in Rights-of-Way, including the specific location of facilities in the Rights-of-Way, and must in any event install Cable System facilities in a manner that minimizes interference with the use of the Rights-of-Way by others, including others that may be installing communications facilities. Within limits reasonably related to the City's role in protecting public health, safety, and welfare, the City may require that Cable System facilities be installed at a particular time, at a specific place, or in a particular manner as a condition of access to a particular Right-of-Way; may deny access if Grantee is not willing to comply with City's requirements; and may remove, or require removal of, any facility that is not installed by Grantee in compliance with the requirements established by the City, or which is installed without prior City approval of the time, place, or manner of installation, and charge Grantee for all the costs associated with removal; and may require Grantee to cooperate with others to minimize adverse impacts on the Rights-of-Way through joint trenching and other arrangements.

SECTION 4 - Service Obligations

4.1. General Service Obligation. The Grantee shall make Cable Service available to every residential dwelling unit within the Franchise Area where the minimum density is at least thirty (30) dwelling units per mile and is within one (1) mile of the existing Cable System. Subject to the density requirement, Grantee shall offer Cable Service to all new homes or previously unserved homes located within 125 feet of the Grantee's distribution cable.

The Grantee may elect to provide Cable Service to areas not meeting the above density and distance standards. The Grantee may impose an additional charge in excess of its regular installation charge for any service installation requiring a drop in or line extension in excess of the above standards. Any such additional charge shall be computed on a time plus materials basis to be calculated on that portion of the installation that exceeds the standards set forth above.

4.2. Programming. The Grantee shall offer to all Customers a diversity of video programming services.

4.3. No Discrimination. The Grantee shall not discriminate or permit discrimination between or among any Persons in the availability of Cable Services or other services provided in connection with the Cable System in the Franchise Area. It shall be the right of all Persons to receive all available services provided on the Cable System so long as such Person's financial or other obligations to the Grantee are satisfied. Nothing contained herein shall prohibit the Grantee from offering bulk discounts, promotional discounts, package discounts, or other such pricing strategies as part of its business practice.

4.4. New Developments. The Franchising Authority shall provide the Grantee with written notice of the issuance of building or development permits for planned developments within the Franchise Area requiring undergrounding of cable facilities. The Franchising Authority agrees to require the developer, as a condition of issuing the permit, to give the Grantee access to open trenches for deployment of cable facilities and at least ten (10) business days written notice of the date of availability of open trenches. Notwithstanding the foregoing, the Grantee shall not be required to utilize any open trench.

SECTION 5 - Fees and Charges to Customers

5.1. All rates, fees, charges, deposits and associated terms and conditions to be imposed by the Grantee or any affiliated Person for any Cable Service as of the Effective Date shall be in accordance with applicable FCC's rate regulations. Before any new or modified rate, fee, or charge is imposed, the Grantee shall follow the applicable FCC notice requirements and rules and notify affected Customers, which notice may be by any means permitted under applicable law.

SECTION 6 - Customer Service Standards; Customer Bills; and Privacy Protection

6.1. Customer Service Standards. The Franchising Authority hereby adopts the customer service standards set forth in Part 76, §76.309 of the FCC's rules and regulations, as amended. The Grantee shall comply in all respects with the customer service requirements established by the FCC.

6.2. Customer Bills. Customer bills shall be designed in such a way as to present the information contained therein clearly and comprehensibly to Customers, and in a way that (A) is not misleading and (B) does not omit material information. Notwithstanding anything to the contrary in Section 6.1, above, the Grantee may, in its sole discretion, consolidate costs on Customer bills as may otherwise be permitted by Section 622(c) of the Cable Act (47 U.S.C. §542(c)).

6.3. Privacy Protection. The Grantee shall comply with all applicable federal and state privacy laws, including Section 631 of the Cable Act and regulations adopted pursuant thereto.

SECTION 7 - Oversight and Regulation by Franchising Authority

7.1. Franchise Fees. The Grantee shall pay to the Franchising Authority a franchise fee in an amount equal to five percent (5%) of annual Gross Revenues received from the operation of the Cable System to provide Cable Service in the Franchise Area; provided, however, that Grantee shall not be compelled to pay any higher percentage of franchise fees than any other video service provider providing service in the Franchise Area. The payment of franchise fees shall be made on a quarterly basis and shall be due thirty (30) days after the close of each calendar quarter. A report prepared by a

representative of the Grantee showing the basis for the computation of the Franchise Fees paid during that period shall either accompany the franchise fee payment or be provided under separate cover.

7.2. Franchise Fees Subject to Audit.

7.2.1. Upon reasonable prior written notice and no more than once annually, during normal business hours at Grantee's principal business office, the Franchising Authority shall have the right to inspect the Grantee's financial records used to calculate the Franchising Authority's franchise fees; provided, however, that any such inspection shall take place within three (3) years from the date the Franchising Authority receives such payment, after which period any such payment shall be considered final.

7.2.2. Upon the completion of any such audit by the Franchising Authority, the Franchising Authority shall provide to the Grantee a final report setting forth the Franchising Authority's findings in detail, including any and all substantiating documentation. In the event of an alleged underpayment, the Grantee shall have thirty (30) days from the receipt of the report to provide the Franchising Authority with a written response agreeing to or refuting the results of the audit, including any substantiating documentation. Based on these reports and responses, the parties shall agree upon a "Finally Settled Amount." For purposes of this Section, the term "Finally Settled Amount(s)" shall mean the agreed upon underpayment, if any, to the Franchising Authority by the Grantee as a result of any such audit. If the parties cannot agree on a "Final Settlement Amount," the parties shall submit the dispute to a mutually agreed upon mediator within sixty (60) days of reaching an impasse. In the event an agreement is not reached at mediation, either party may bring an action to have the disputed amount determined by a court of law.

7.2.3. Any "Finally Settled Amount(s)" due to the Franchising Authority as a result of such audit shall be paid to the Franchising Authority by the Grantee within thirty (30) days from the date the parties agree upon the "Finally Settled Amount." Once the parties agree upon a Finally Settled Amount and such amount is paid by the Grantee, the Franchising Authority shall have no further rights to audit or challenge the payment for that period. The Franchising Authority shall bear the expense of its audit of the Grantee's books and records.

7.3. Oversight of Franchise. In accordance with applicable law, the Franchising Authority shall have the right to, on reasonable prior written notice and in the presence of Grantee's employee, periodically inspect the construction and maintenance of the Cable System in the Franchise Area as necessary to monitor Grantee's compliance with the provisions of this Franchise Agreement.

7.4. Technical Standards. The Grantee shall comply with all applicable technical standards of the FCC as published in subpart K of 47 C.F.R. § 76. To the extent those standards are altered, modified, or amended during the term of this Franchise, the Grantee shall comply with such altered, modified or amended standards within a reasonable

period after such standards become effective. The Franchising Authority shall have, upon written request, the right to obtain a copy of tests and records required to be performed pursuant to the FCC's rules.

7.5. Maintenance of Books, Records, and Files.

7.5.1. Books and Records. Throughout the term of this Franchise Agreement, the Grantee agrees that the Franchising Authority may review the Grantee's books and records regarding customer service performance levels in the Franchise Area to monitor Grantee's compliance with the provisions of this Franchise Agreement, upon reasonable prior written notice to the Grantee, at the Grantee's business office, during normal business hours, and without unreasonably interfering with Grantee's business operations. All such documents that may be the subject of an inspection by the Franchising Authority shall be retained by the Grantee for a minimum period of three (3) years.

7.5.2. Proprietary Information. Notwithstanding anything to the contrary set forth in this Section, the Grantee shall not be required to disclose information which it reasonably deems to be proprietary or confidential in nature. The Franchising Authority agrees to treat any proprietary information disclosed by the Grantee as confidential and only to disclose it to those employees, representatives, and agents of the Franchising Authority that have a need to know in order to enforce this Franchise Agreement and who agree to maintain the confidentiality of all such information. The Grantee shall not be required to provide Customer information in violation of Section 631 of the Cable Act or any other applicable federal or state privacy law. For purposes of this Section, the terms "proprietary or confidential" include, but are not limited to, information relating to the Cable System design, customer lists, marketing plans, financial information unrelated to the calculation of franchise fees or rates pursuant to FCC rules, or other information that is reasonably determined by the Grantee to be competitively sensitive. Grantee may make proprietary or confidential information available for inspection but not copying or removal by the Franchising Authority's representative. The State of New Mexico has adopted a Public Records Act which applies to all municipalities, including the City of Rio Communities. Pursuant to the New Mexico Inspection of Public Records Act (IPRA), upon receipt of request for information and documentation, the City of Rio Communities will be required to disclose such documents as may be required under the legislation and/or Court Orders within 15 days after Franchise Authority receives the initial IPRA request. Grantee agrees to work with Franchise Authority in order to comply with the statutory time limits.

SECTION 8 – Transfer of Cable System or Franchise or Control of Grantee

8.1. Neither the Grantee nor any other Person may transfer the Cable System or the Franchise without the prior written consent of the Franchising Authority, which consent shall not be unreasonably withheld or delayed. No transfer of control of the Grantee, defined as an acquisition of 51% or greater ownership interest in Grantee, shall take place without the prior written consent of the Franchising Authority, which consent shall not be unreasonably withheld or delayed. No consent shall be required, however, for (i) a transfer in trust, by mortgage, hypothecation, or by assignment of any rights, title, or interest of the

Grantee in the Franchise or in the Cable System in order to secure indebtedness, or (ii) a transfer to an entity directly or indirectly owned or controlled by Comcast Corporation. Within thirty (30) days of receiving a request for consent, the Franchising Authority shall, in accordance with FCC rules and regulations, notify the Grantee in writing of the additional information, if any, it requires to determine the legal, financial and technical qualifications of the transferee or new controlling party. If the Franchising Authority has not taken final action on the Grantee's request for consent within one hundred twenty (120) days after receiving such request, consent shall be deemed granted.

SECTION 9 - Insurance and Indemnity

9.1. Insurance. Throughout the term of this Franchise Agreement, the Grantee shall, at its own cost and expense, maintain Comprehensive General Liability Insurance and provide the Franchising Authority certificates of insurance designating the Franchising Authority and its officers, boards, commissions, councils, elected officials, agents and employees as additional insureds and demonstrating that the Grantee has obtained the insurance required in this Section. Such policy or policies shall be in the minimum amount of One Million Dollars (\$1,000,000.00) for bodily injury or death to any one person, and One Million Dollars (\$1,000,000.00) for bodily injury or death of any two or more persons resulting from one occurrence, and One Million Dollars (\$1,000,000.00) for property damage resulting from any one accident. Such policy or policies shall be non-cancelable except upon thirty (30) days prior written notice to the Franchising Authority. The Grantee shall provide workers' compensation coverage in accordance with applicable law. The Grantee shall indemnify and hold harmless the Franchising Authority from any workers compensation claims to which the Grantee may become subject during the term of this Franchise Agreement

9.2. Indemnification. The Grantee shall indemnify, defend and hold harmless the Franchising Authority, its officers, employees, and agents from and against any liability or claims resulting from property damage or bodily injury (including accidental death) that arise out of the Grantee's construction, operation, maintenance or removal of the Cable System, including, but not limited to, reasonable attorneys' fees and costs, provided that the Franchising Authority shall give the Grantee written notice of its obligation to indemnify and defend the Franchising Authority within twenty-five (25) business days of receipt of a claim or action pursuant to this Section. If the Franchising Authority determines that it is necessary for it to employ separate counsel, the costs for such separate counsel shall be the responsibility of the Franchising Authority.

SECTION 10 - System Description and Service

10.1. System Capacity. During the term of this Agreement the Grantee's Cable System shall be capable of providing a minimum of 85 channels of video programming with satisfactory reception available to its customers in the Franchise Area.

SECTION 11 - Enforcement and Termination of Franchise

11.1. Notice of Violation or Default. In the event the Franchising Authority believes that the Grantee has not complied with the material terms of the Franchise, it shall notify the Grantee in writing with specific details regarding the exact nature of the alleged noncompliance or default.

11.2. Grantee's Right to Cure or Respond. The Grantee shall have forty-five (45) days from the receipt of the Franchising Authority's written notice: (A) to respond to the Franchising Authority, contesting the assertion of noncompliance or default; or (B) to cure such default; or (C) in the event that, by nature of the default, such default cannot be cured within the forty-five (45) day period, initiate reasonable steps to remedy such default and notify the Franchising Authority of the steps being taken and the projected date that the cure will be completed.

11.3. Enforcement. Subject to applicable federal and state law, in the event the Franchising Authority, after such public hearing, determines that the Grantee is in default of any material provision of the Franchise, the Franchising Authority may:

11.3.1. seek specific performance of any provision that reasonably lends itself to such remedy as an alternative to damages, or seek other equitable relief; or

11.3.2. in the case of a substantial default of a material provision of the Franchise, declare the Franchise Agreement to be revoked in accordance with the following:

(i) The Franchising Authority shall give written notice to the Grantee of its intent to revoke the Franchise on the basis of a pattern of noncompliance by the Grantee, including two or more instances of substantial noncompliance with a material provision of the Franchise. The notice shall set forth with specificity the exact nature of the noncompliance. The Grantee shall have ninety (90) days from the receipt of such notice to object in writing and to state its reasons for such objection. In the event the Franchising Authority has not received a response from the Grantee or upon receipt of the response does not agree with the Grantee's proposed remedy, it may then seek termination of the Franchise at a public hearing. The Franchising Authority shall cause to be served upon the Grantee, at least ten (10) days prior to such public hearing, a written notice specifying the time and place of such hearing and stating its intent to request termination of the Franchise.

(ii) At the designated hearing, the Franchising Authority shall give the Grantee an opportunity to state its position on the matter, present evidence and question witnesses, after which it shall determine whether or not the Franchise shall be terminated. The decision of the Franchising Authority shall be in writing and shall be delivered to the Grantee by certified mail.

11.5. Technical Violation. The Franchising Authority agrees that it is not its intention to subject the Grantee to penalties, fines, forfeitures or revocation of the Franchise

for so-called “technical” breach(es) or violation(s) of the Franchise, which shall include, but not be limited, to the following:

11.5.1. in instances or for matters where a violation or a breach of the Franchise by the Grantee was good faith error that resulted in no or minimal negative impact on the Customers within the Franchise Area; or

11.5.2. where there existed circumstances reasonably beyond the control of the Grantee and which precipitated a violation by the Grantee of the Franchise, or which were deemed to have prevented the Grantee from complying with a term or condition of the Franchise.

SECTION 12 – Competitive Equity

(A) The Grantee acknowledges and agrees that the Franchising Authority reserves the right to grant one (1) or more additional franchises or other similar lawful authorization to provide Cable Services within the Franchising Authority; provided, the Franchising Authority agrees that, within ninety (90) days of the Grantee's request, it shall amend this Franchise to include any material terms or conditions that it makes available to the new entrant, or provide relief from existing material terms or conditions, so as to insure that the regulatory and financial burdens on each entity are materially equivalent. "Material terms and conditions" include but are not limited to franchise fees; insurance; System build-out requirements; security instruments; Public, Education and Government Access Channels and support; customer service standards; required reports and related record keeping; and notice and opportunity to cure breaches. The parties agree that this provision shall not require a word for word identical franchise or authorization for a competitive entity so long as the regulatory and financial burdens on each entity are materially equivalent. Video Programming services delivered over wireless broadband networks are specifically exempted from the requirements of this Section.

(B) Notwithstanding any provision to the contrary, at any time that a non-wireless facilities based entity, legally authorized by state or federal law, makes available for purchase by Subscribers or customers, Cable Services or multiple Channels of Video Programming within the Franchise Area without a franchise or other similar lawful authorization granted by the Franchising Authority, then Grantee may seek modification as per (A) above, or the term of Grantee's Franchise shall, upon ninety (90) days written notice from Grantee, be shortened so that the Franchise shall be deemed to expire on a date six (6) months from the first day of the month following the date of Grantee's notice.

(C) Notwithstanding any provision to the contrary, should any non-wireless facilities-based entity provide Cable Service within the Franchise Area during the term of this Franchise without a franchise granted by the Franchising Authority, then Grantee may assert, at Grantee's option, that this Franchise is rendered "commercially impracticable" and invoke the modification procedures set forth in Section 625 of the Cable Act.

13.4. Entire Agreement. This Franchise Agreement, including all Exhibits, embodies the entire understanding and agreement of the Franchising Authority and the Grantee with respect to the subject matter hereof and supersedes all prior understandings, agreements and communications, whether written or oral. All ordinances or parts of ordinances that are in conflict with or otherwise impose obligations different from the provisions of this Franchise Agreement are superseded by this Franchise Agreement.

13.5. Severability. If any section, subsection, sentence, clause, phrase, or other portion of this Franchise Agreement is, for any reason, declared invalid, in whole or in part, by any court, agency, commission, legislative body, or other authority of competent jurisdiction, such portion shall be deemed a separate, distinct, and independent portion. Such declaration shall not affect the validity of the remaining portions hereof, which other portions shall continue in full force and effect.

13.6. Governing Law. This Franchise Agreement shall be deemed to be executed in the State of New Mexico, and shall be governed in all respects, including validity, interpretation and effect, and construed in accordance with, the laws of the State of New Mexico, as applicable to contracts entered into and performed entirely within the State. Venue for all disputes and subsequent litigation among the parties shall be in the Thirteenth Judicial District Court, State of New Mexico.

13.7. Modification. No provision of this Franchise Agreement shall be amended or otherwise modified, in whole or in part, except by an instrument, in writing, duly executed by the Franchising Authority and the Grantee, which amendment shall be authorized on behalf of the Franchising Authority through the adoption of an appropriate resolution or order by the Franchising Authority, as required by applicable law.

13.8. No Third-Party Beneficiaries. Nothing in this Franchise Agreement is intended to confer third-party beneficiary status on any member of the public to enforce the terms of this Franchise Agreement.

13.9. No Waiver of Rights. Nothing in this Franchise Agreement shall be construed as a waiver of any rights, substantive or procedural, Grantee may have under federal or state law unless such waiver is expressly stated herein.

**PASSED, APPROVED AND ADOPTED THIS ____th DAY OF SEPTEMBER, 2023
BY THE GOVERNING BODY OF THE CITY OF RIO COMMUNITIES, NEW
MEXICO.**

City of Rio Communities Governing Body

Joshua Ramsell, Mayor

Margaret (Peggy) Gutjahr,
Mayor Pro-tem

Jim Winters,
Councilor

Arthur (Art) Apodaca
Councilor

Lawrence R. Gordon
Councilor

Attest:

Lalena Aragon
Deputy Clerk

IN WITNESS WHEREOF, this Franchise Agreement has been executed by the duly authorized representatives of the parties as set forth below, as of the date set forth below:

For the City of Rio Communities, New Mexico:

By: _____

Name: Martin Moore

Title: City Manager

Date: _____

For Comcast of New Mexico, LLC.

By: _____

Name: _____

Title: _____

Date: _____

DRAFT

PURCHASE AGREEMENT CONTRACT

CITY OF RIO COMMUNITIES

Invitation to Bid #2023-0101 DHSEM Projects

THIS AGREEMENT is made and entered into by and between the Governing Body of the City of Rio Communities, State of New Mexico, hereinafter referred to as the "City" and **Desert Fox, LLC**, hereinafter referred to as the "Contractor", and is effective as of the date set forth below upon which it is executed by the Purchasing Agent and the Governing Body.

IT IS AGREED BETWEEN THE PARTIES:

1. Scope of Work.

The Contractor shall deliver products or perform the work outlined on the Scope of Work attached hereto as **Attachment 1** and incorporated herein by reference. Product(s) shall be delivered, or work performed only upon receipt of a valid Purchase Order issued by the City that specifically identifies the products or services to be provided by the Contractor.

2. Compensation.

A. The City shall pay to the Contractor in full payment for product(s) accepted or services satisfactorily performed based on the price(s) found in the Bid Form at **Attachment 1**.

B. Payment is subject to availability of funds pursuant to the Appropriations Paragraph set forth below. All invoices **MUST BE** received by the City no later than fifteen (15) days after the termination of the Fiscal Year in which the services were delivered. Invoices received after such date **WILL NOT BE PAID**.

C. The Contractor shall submit an accurate invoice for each purchase. Any reimbursement of taxes due to the Contractor shall be shown as a separate item. Invoices shall refer to the Purchase Order Number and shall be itemized unless otherwise specified by the City. Invoices are to be mailed to: City of Rio Communities Accounts Payable, 360 Rio Communities Blvd. Rio Communities, NM 87002

D. The payment of taxes due for any money received under this Agreement shall be the Contractor's sole responsibility and shall be reported under the Contractor's Federal and State tax identification number(s).

3. Term.

This Agreement shall terminate upon acceptance by the City and payment for the specified product(s) or services.

4. Termination.

A. Termination. This Agreement may be terminated by either of the parties hereto upon written notice delivered to the other party at least thirty (30) days prior to the intended date of termination. Except as otherwise allowed or provided under this Agreement, the City's sole liability upon such termination shall be to pay for product(s) delivered and accepted or work performed prior to the Contractor's receipt of the notice of termination, if the City is the terminating party, or the Contractor's sending of the notice of termination, if the Contractor is the terminating party; provided, however, that a notice of termination shall not nullify or otherwise affect either party's liability for pre-termination defaults under or breaches of this Agreement. The Contractor shall submit an invoice for product(s) delivered or such work performed within thirty (30) days of receiving or sending the notice of termination. Notwithstanding the foregoing, this Agreement may be terminated immediately upon written notice to the Contractor if the Contractor becomes unable to perform the services contracted for, as determined by the City or if, during the term of this Agreement, the Contractor or any of its officers, employees or agents is indicted for fraud, embezzlement or other crime due to misuse of government funds or due to the Appropriations paragraph herein. THIS PROVISION IS NOT EXCLUSIVE AND DOES NOT WAIVE THE CITY'S OTHER LEGAL RIGHTS AND REMEDIES CAUSED BY THE CONTRACTOR'S DEFAULT/BREACH OF THIS AGREEMENT.

B Termination Management. Immediately upon receipt by either the City or the Contractor of notice of termination of this Agreement, the Contractor shall: 1) not incur any further obligations for salaries, services or any other expenditure of funds under this Agreement without written approval of the City; 2) comply with all directives issued by the City in the notice of termination as to the performance of work under this Agreement; and 3) take such action as the City shall direct for the protection, preservation, retention or transfer of all property titled to the City and records generated under this Agreement. Any non-expendable personal property or equipment provided to or purchased by the Contractor with Contract funds shall become property of the City upon termination and shall be submitted to the City as soon as practicable.

5. Appropriations.

The terms of this Agreement are contingent upon sufficient appropriations and authorization being made by the Governing Body for the performance of this Agreement. If sufficient appropriations and authorization are not made by the Governing Body, this Agreement shall terminate immediately upon written notice being given by the City to the Contractor. The City's decision as to whether sufficient appropriations are available shall be accepted by the Contractor and shall be final. If the City proposes an amendment to the Agreement to unilaterally reduce funding, the Contractor shall have the option to terminate the Agreement or to agree to the reduced funding, within thirty (30) days of receipt of the proposed amendment.

6. Insurance.

The Contractor agrees to obtain and maintain, at the Contractor's expense, such insurance as will protect the Contractor from claims under the Workman's Compensation Act and such comprehensive general liability and automobile insurance as will protect the City and the Contractor from all claims for bodily injury, death, or property damage which may arise from the performance by the Contractor, or by the Contractor employees, for the Contractor's functions and services required under this Agreement. Such insurance shall be in an amount not less than **\$1,000,000.00** for injury to any one person and **\$1,000,000.00** on account of any one accident and in the amount of not less than **\$1,000,000.00** for property damage. The comprehensive liability insurance shall name the City an additional insured with specific endorsements so naming the City for any claims against the City arising from the work performed by the Contractor under this Agreement. The Contractor further agrees to procure and maintain professional liability (errors and omissions, or "E&O") insurance in an amount not less than \$2,000,000.00 per claim and in the aggregate. Prior to commencement of any work, the Contractor shall furnish to the City a certificate that complies with this paragraph. The certificate shall provide that the policy shall not be canceled until at least thirty (30) calendar days prior written notice shall have been given to the City. Contractor shall provide annual updates of the certificate to demonstrate the policy remains in effect for the duration of this Agreement. The failure to have valid policies of insurance in full force and effect at any time during the term of this agreements shall constitute a material breach of this agreement.

Employer's liability coverage will be required of the Contractor and any subcontractor for any class of employee engaged in work under this agreement that is not protected under the Workmen's Compensation Statute. All insurance will be by insurers acceptable to the City and authorized to do business in the state of New Mexico, and who are rated A,A- (A.M. Best Ratings) or AA+/- (S&P). Except as provided below, coverage shall be on an occurrence basis. All insurance policies shall contain a waiver of subrogation against the City. All insurance policies shall be primary. Coverage shall be on ISO coverage forms. Deductibles in excess of \$10,000 per claim may only be approved by the City. Coverage shall be as broad as that provided in ISO CG 20 01 04 13. Self-insured retentions must be declared and approved by the City. Automobile coverage shall be ISO Form CA 001 covering Code 1 (any auto) with the limits of **\$2,000,000** per accident for bodily injury a property damage. If an E&O policy is on a claim made basis, then the date of the policy must be shown and must be before the date of the Contract or the beginning of the scope of work under the Contract, be maintained and evidence for such coverage to be provided for at least five (5) years after completion of the work under the Contract. If such coverage is cancelled or not renewed, and not replaced with another claims made policy form with a retroactive date prior to the effective date of the Contract, then Contractor must purchase "extended reporting" coverage for a minimum of five (5) years after completion of work under the Contract.

7. **Status of Contractor.**

The Contractor and its agents and employees are independent contractors providing product(s) or performing services for the City and are not employees of the City of Rio Communities. The Contractor and its agents and employees shall not accrue leave, retirement, insurance, bonding, use of City vehicles, or any other benefits afforded to employees of the City of Rio Communities as a result of this Agreement. The Contractor acknowledges that all sums received hereunder are reportable by the Contractor for tax purposes, including without limitation, self-employment, and business income tax. The Contractor agrees not to purport to bind the City of Rio Communities unless the Contractor has express written authority to do so, and then only within the strict limits of that authority.

8. **Assignment.**

The Contractor shall not assign or transfer any interest in this Agreement or assign any claims for money due or to become due under this Agreement without the prior written approval of the City. No such assignment or transfer shall relieve the Contractor from the obligations and liabilities under this Agreement.

9. **Subcontracting.**

Not applicable.

10. **Release.**

Final payment of the amounts due under this Agreement shall operate as a release of the procuring agency of the City, its officers and employees, and the City of Rio Communities from all liabilities, claims and obligations whatsoever arising from or under this Agreement.

11. **Confidentiality.**

Any confidential information provided to or developed by the Contractor in the performance of this Agreement shall be kept confidential and shall not be made available to any individual or organization by the Contractor without the prior written approval of the City.

12. **Product of Service -- Copyright.**

All materials developed or acquired by the Contractor under this Agreement shall become the property of the City of Rio Communities and shall be delivered to the City no later than the termination date of this Agreement. Nothing developed or produced, in whole or in part, by the Contractor under this Agreement shall be the subject of an application for copyright or other claim of ownership by or on behalf of the Contractor.

13. **Conflict of Interest; Governmental Conduct Act.**

A. The Contractor represents and warrants that it presently has no interest and, during the term of this Agreement, shall not acquire any interest, direct or indirect, which would conflict in any manner or degree with the performance or services required under the Agreement.

B. The Contractor further represents and warrants that it has complied with, and, during the term of this Agreement, will continue to comply with, and that this Agreement complies with all applicable provisions of the Governmental Conduct Act, Chapter 10, Article 16 NMSA 1978. Without in anyway limiting the generality of the foregoing, the Contractor specifically represents and warrants that:

1) in accordance with Section 10-16-4.3 NMSA 1978, the Contractor does not employ, has not employed, and will not employ during the term of this Agreement any City employee while such employee was or is employed by the City and participating directly or indirectly in the City's contracting process;

2) this Agreement complies with Section 10-16-7(B) NMSA 1978 because (i) the Contractor is not a public officer or employee of the City; (ii) the Contractor is not a member of the family of a public officer or employee of the City; (iii) the Contractor is not a business in which a public officer or employee or the family of a public officer or employee has a substantial interest; or (iv) if the Contractor is a public officer or employee of the City, a member of the family of a public officer or employee of the City, or a business in which a public officer or employee of the City or the family of a public officer or employee of the City has a substantial interest, public notice was given as required by Section 10-16-7(B) NMSA 1978 and this Agreement was awarded pursuant to a competitive process;

3) in accordance with Section 10-16-8(C) NMSA 1978, (i) the Contractor is not, and has not been represented by, a person who has been a public officer or employee of the City within the preceding year and whose official act directly resulted in this Agreement and (ii) the Contractor is not, and has not been assisted in any way regarding this transaction by, a former public officer or employee of the City whose official act, while in City employment, directly resulted in the City's making this Agreement;

4) in accordance with Section 10-16-13 NMSA 1978, the Contractor has not directly participated in the preparation of specifications, qualifications or evaluation criteria for this Agreement or any procurement related to this Agreement; and

5) in accordance with Section 10-16-3 and Section 10-16-13.3 NMSA 1978, the Contractor has not contributed, and during the term of this Agreement shall not contribute, anything of value to a public officer or employee of the City.

C. Contractor's representations and warranties in Paragraphs A and B of this Article 12 are material representations of fact upon which the City relied when this Agreement was entered into by the parties. Contractor shall provide immediate written notice to the City if, at any time during the term of this Agreement, Contractor learns that Contractor's representations and warranties in Paragraphs A and B of this Article 12 were erroneous on the effective date of this Agreement or have become erroneous by reason of new or changed circumstances. If it is later determined that Contractor's representations and warranties in Paragraphs A and B of this Article 12 were erroneous on the effective date of this Agreement or have become erroneous by reason of new or changed circumstances, in addition to other remedies available to the City and notwithstanding anything in the Agreement to the contrary, the City may immediately terminate the Agreement.

D. All terms defined in the Governmental Conduct Act have the same meaning in this Article 12(B).

14. Amendment.

This Agreement shall not be altered, changed, or amended except by instrument in writing executed by the parties hereto and all other required signatories.

15. Merger.

This Agreement incorporates all the Agreements, covenants and understandings between the parties hereto concerning the subject matter hereof, and all such covenants, Agreements and understandings have been merged into this written Agreement. No prior Agreement or understanding, oral or otherwise, of the parties or their agents shall be valid or enforceable unless embodied in this Agreement.

16. Penalties for violation of law.

The Procurement Code, Sections 13-1-28 through 13-1-199, NMSA 1978, imposes civil and criminal penalties for its violation. In addition, the New Mexico criminal statutes impose felony penalties for illegal bribes, gratuities, and kickbacks.

17. Equal Opportunity Compliance.

The Contractor agrees to abide by all federal, state and City laws and rules and regulations, pertaining to equal employment opportunity. In accordance with all such laws, the Contractor assures that no person in the United States shall, on the grounds of race, religion, color, national origin, ancestry, sex, age, physical or mental handicap, or serious medical condition, spousal affiliation, sexual orientation, or gender identity, be excluded from employment with or participation in, be denied the benefits of, or be otherwise subjected to discrimination under any program or activity performed under this Agreement. If Contractor is found not to be in compliance with these requirements during the life of this Agreement, Contractor agrees to take appropriate steps to correct these deficiencies.

18. Applicable Law.

In any action, suit or legal dispute arising from this Agreement, the Contractor agrees that the laws of the State of New Mexico shall govern, and that venue will lie in the Seventh Judicial District Court in City of Rio Communities. By execution of this Agreement, Contractor acknowledges and agrees to the jurisdiction of the courts of the State of New Mexico over any and all lawsuits arising under or out of any term of this Agreement.

19. Workers Compensation.

The Contractor agrees to comply with state laws and rules applicable to workers compensation benefits for its employees. If the Contractor fails to comply with the Workers Compensation Act and applicable rules when required to do so, this Agreement may be terminated by the City.

20. Records and Financial Audit.

The Contractor shall maintain detailed time and expenditure records that indicate the date; time, nature and cost of product(s) delivered, or services rendered during the Agreement's term and effect and retain them for a period of three (3) years from the date of final payment under this Agreement. The records shall be subject to inspection by the City, the Department of Finance and Administration and the State Auditor. The City shall have the right to audit billings both before and after payment. Payment under this Agreement shall not foreclose the right of the City to recover excessive or illegal payments

21. Disclaimer and Hold Harmless.

City of Rio Communities shall not be liable to the Contractor, or the Contractor's successors, heirs, administrators, or assigns, for any loss, damage, or injury, whether to Contractor's person or property, occurring in connection with Contractor's performance of Contractor's duties according to this Agreement. Contractor shall hold City of Rio Communities harmless from all loss, damage, and injury, including court costs and attorney fees, incurred by City of Rio Communities in connection with the performance by Contractor of Contractor's duties according to this Agreement.

22. Indemnification.

The Contractor shall defend, indemnify and hold harmless the City of Rio Communities from all actions, proceeding, claims, demands, costs, damages, attorneys' fees and all other liabilities and expenses of any kind from any source which may arise out of the performance of this Agreement, caused by the negligent act or failure to act of the Contractor, its officers, employees, servants, subcontractors or agents, or if caused by the actions of any client of the Contractor resulting in injury or damage to persons or property during the time when the Contractor or any officer, agent, employee, servant or subcontractor thereof has or is performing services pursuant to this Agreement. In the event that any action, suit or proceeding related to the services performed by the Contractor or any officer, agent, employee, servant or subcontractor under this Agreement is brought against the Contractor, the Contractor shall, as soon as practicable but no later than two (2) days after it receives notice thereof, notify the legal counsel of the City of Rio Communities and the New Mexico Association of Counties by certified mail.

23. Invalid Term or Condition.

If any term or condition of this Agreement shall be held invalid or unenforceable, the remainder of this Agreement shall not be affected and shall be valid and enforceable.

24. Enforcement of Agreement.

A party's failure to require strict performance of any provision of this Agreement shall not waive or diminish that party's right thereafter to demand strict compliance with that or any other provision. No waiver by a party of any of its rights under this Agreement shall be effective unless express and in writing, and no effective waiver by a party of any of its rights shall be effective to waive any other rights.

25. Authority.

If Contractor is other than a natural person, the individual(s) signing this Agreement on behalf of Contractor represents and warrants that he or she has the power and authority to bind Contractor, and that no further action, resolution, or approval from Contractor is necessary to enter into a binding contract.

26. Lobbying.

No federal appropriated funds can be paid or will be paid, by or on behalf of the CONTRACTOR, or any person for influencing or attempting to influence an officer or employee of any City, a Member of Congress, an officer or employee of Congress, or an employee of a Member of Congress in connection with the awarding of any Federal contract, or the making of any Federal grant, the making of any federal loan, the entering into of any cooperative agreement, or modification of any Federal contract, grant, loan, or cooperative agreement. If any funds other than federal appropriated funds have been paid or will be paid to any person influencing or attempting to influence an officer or employee of any City, a Member of Congress, an officer or employee of Congress, or an employee of a Member of Congress in connection of this federal contract, grant, loan, or cooperative agreement, the CONTRACTOR shall complete and submit Standard Form LLL, "Disclosure Form to Report Lobbying," in accordance with its instructions.

27. Non-Collusion.

In signing this bid the Bidder certifies he/she has not, either directly or indirectly, entered into action in restraint of free competitive bidding in connection with this offer submitted to the City.

28. Survival.

The Agreement paragraphs titled "Patent, Copyright, Trademark, and Trade Secret Indemnification" and "Indemnification" shall survive the expiration of this Agreement. Software licenses, leases, maintenance, and any other unexpired Agreements that were entered into under the terms and conditions of this Agreement shall survive this Agreement.

29. Succession.

This Agreement shall extend to and be binding upon the successors and assigns of the parties.

30. Force Majeure.

A party shall be excused from performance under this Agreement for any period that the party is prevented from performing as a result of an act of God, strike, war, civil disturbance, epidemic, or court order, provided that the party has prudently and promptly acted to take any and all steps that are within the party's control to ensure performance. Subject to this provision, such non-performance shall not be deemed a default or a ground for termination.

31. Mediation.

In the event a dispute arises as to the rights and obligations among the parties hereto, the parties agree to attempt to resolve the dispute through mediation as a condition

precedent to seeking legal and equitable remedies. The parties agree to evenly split the costs of any such mediation services. The parties shall mutually agree upon the choice of mediator. In the event the parties have not agreed upon a mediator within twenty (20) days of written notice to the other regarding the dispute, then a list of seven potential mediators will be obtained from the New Mexico Association of Counties and the parties shall utilize a striking process until a mediator is agreed upon.

32. Notice to Proceed.

It is expressly understood that this Agreement is not binding upon the City until it is executed by the Governing Body after voting on the Contract at a public meeting or unless it is executed by the City of Rio Communities City Manager, if the amount of the Contract is \$20,000.00 or less. Further, the Contractor is not to proceed with its obligations under the Agreement until the Contractor has received a fully executed copy of the Agreement and one or more valid Purchase Orders issued by the City.

33. Attorney's Fees.

In the event this Agreement results in dispute, mediation, litigation, or settlement between the parties to this Agreement, the prevailing party of such action shall NOT be entitled to an award of attorneys' fees and court costs.

34. Cooperation.

All parties hereto will fully cooperate with the other and their respective counsel, accountant, and agents in connection with any steps required to be taken under this Agreement.

35. Incorporation and Order of Precedence.

This Invitation for Bids and the Contractor's Bid Form are incorporated by reference into this Agreement and are made a part of this Agreement. In the event of any conflict among these documents, the following order of precedence shall apply:

1. Any Contract amendment(s), in reverse chronological order; then
2. this Contract itself; then
3. the Invitation for Bids; then
4. the Contractor's Bid Form; then
5. the Contractor's standard agreement terms and conditions (which may or may not have been submitted as part of the Contractor's bid).

36. Patent, Copyright, Trademark and Trade Secret Indemnification.

A. The Contractor shall defend, at its own expense, the City of Rio Communities against any claim that any product or service provided under this Agreement infringes any patent, copyright or trademark in the United States or Puerto Rico, and shall pay all costs, damages, and attorneys' fees that a court finally awards as a result of any such claim. In addition, if any third party obtains a judgment against the City of Rio

Communities based upon the Contractor's trade secret infringement relating to any product or service provided under this Agreement, the Contractor agrees to reimburse the City of Rio Communities for all costs, attorneys' fees and the amount of the judgment. To qualify for such defense and/or payment, the City of Rio Communities shall:

- i. give the Contractor prompt written notice of any claim;
 - ii. allow the Contractor to control the defense or settlement of the claim; and
 - iii. cooperate with the Contractor in a reasonable way to facilitate the defense or settlement of the claim.
- B. If any product or service becomes, or in the Contractor's opinion is likely to become the subject of a claim of infringement, the Contractor shall at its option and expense:
- i. provide a procuring agency of the City the right to continue using the product or service;
 - ii. replace or modify the product or service so that it becomes non-infringing;
- or
- iii. accept the return of the product or service and refund an amount equal to the depreciated value of the returned product or service, less the unpaid portion of the purchase price and any other amounts which are due to the Contractor. The Contractor's obligation will be void as to any product or service modified by the procuring agency of the City to the extent such modification is the cause of the claim.

37. Escalation Clause.

Price escalation due to increased cost to the Contractor is not allowed.

38. Warranties.

Contractor warrants the materials, supplies or services furnished to be exactly as specified, free from defects in Contractor's design, labor, materials and manufacture, and to be in compliance with any drawings or specifications incorporated herein and with any samples furnished by Contractor. Materials furnished by Contractor shall be accompanied by the manufacturer's written warranty against defects in quality, craftsmanship, and materials.

39. Commercial Warranty.

The Contractor agrees that the supplies or services furnished under this order shall be covered by the most favorable commercial warranties the Contractor gives for such to any customer for such supplies or services. The rights and remedies provided herein shall extend to the City and are in addition to and do not limit any rights afforded to the City by any other clause of this Agreement. Contractor agrees not to disclaim warranties of

fitness for a particular purpose of merchantability. Warranties shall become effective at the time of acceptance.

40. Inspection.

Final inspection and acceptance will be made at the destination. Supplies rejected at the destination for nonconformance with specifications shall be removed at the Contractor's risk and expense, promptly after notice of rejection.

41. Inspection of Plant.

The City may inspect, at any reasonable time, the part of the Contractor's, or any subcontractor's plant or place of business, which is related to the performance of this Contract.

42. Late Payment Charges.

Except as otherwise agreed to: late payment charges may be assessed against the user agency in the amount and under the conditions set forth in Section 13-1-158 NMSA 1978.

43. Overcharge Resulting from Antitrust Violations.

Contractor agrees that any and all claims for overcharge resulting from antitrust violations which are borne by the City as to goods, services, and materials purchased in connection with this bid are hereby assigned to the City.

44. Succession.

This Agreement shall extend to and be binding upon the successors and assigns of the parties.

45. Notices.

Any notice required to be given to either party by this Agreement shall be in writing and shall be delivered in person, by courier service or by U.S. mail, either first class or certified, return receipt requested, postage prepaid, as follows:

To the City: Angela R. Valadez, City of Rio Communities Procurement Officer
 360 Rio Communities Blvd.
 Rio Communities, NM 87002

To the Contractor: _____

IN WITNESS WHEREOF, the parties have executed this Agreement as of the date of signature of all parties.

CONTRACTOR

By: _____ Date: _____
Contractor

Printed Name: _____

Address: _____

CITY OF RIO COMMUNITIES

APPROVED, ADOPTED, AND PASSED on this ____ day of _____, 2023.

GOVERNING BODY OF THE CITY OF RIO COMMUNITIES

JOSHUA RAMSELL MAYOR

MARGARET "PEGGY" GUTJAHR
MAYOR PRO-TEM

ARTHUR APODACA
COUNCILOR

LAWRENCE GORDON
COUNCILOR

JIM WINTERS
COUNCILOR

ATTEST BY:

LALENA ARAGON, DEPUTY CLERK

By: _____ Date: _____
City of Rio Communities Procurement Officer

Attachment 1

Scope of Work

The CONTRACTOR shall deliver products and services to a Procuring Agency which issues a valid Purchase Order at prices not to exceed those shown in the Contractor's Bid Form (ITB 2023-0102 Appendix A). Procuring Agencies reserve the right to negotiate lower pricing upon mutual agreement of the parties.

APPENDIX B

BID FORM

DHSEM PROJECTS

TO: Angela R. Valadez 360 Rio Communities
Rio Communities, NM 87002

The undersigned hereby proposes to perform all work for the DHSEM Projects in accordance with the following:

1. Advertisement for Bids dated 09/21/2023

2. All work required for the **DHSEM PROJECTS** described in the Contract Documents shall be done in accordance with the New Mexico Department of Transportation Standard Specifications for Highway and Bridge Construction, current edition.

3. The Contract Documents, including Special Provisions, Supplementary Technical Specifications, and modifications as indicated.

All of which are incorporated herein and made a part hereof; and to perform said work in accordance with and at the rates and prices or lump sum bid shown in the following bid schedule. (Each item must be bid. The cost of any work added or deducted from the following estimated quantities shall be computed at the unit prices bid.) **Bids shall not include New Mexico gross receipts tax.**

DHSEM PROJECTS BID PROPOSAL BASE BID

BID ITEM	NMDOT ITEM NO.	ITEM DESCRIPTION	UNIT	ESTIMATED QTY	UNIT PRICE	AMOUNT
BASE BID LOT						
1	201000	CLEARING AND GRUBBING	LS	1	\$ 10,000.00	\$ 10,000.00
2	203000	UNCLASSIFIED EXCAVATION	C.Y.	230	\$ 45.00	\$ 10,350.00
3	203100	BORROW	C.Y.	40	\$ 20.00	\$ 800.00
4	207000	SUBGRADE PREPARATION	S.Y.	1,500	\$ 5.00	\$ 7,500.00
5	407000	ASPHALT MATERIAL FOR TACKCOAT	TON	1	\$ 1,500.00	\$ 1,500.00
6	408100	PRIME COAT MATERIAL	TON	3	\$ 1,500.00	\$ 4,500.00
7	414000	COLD MILLING (ASPHALT)	SYIN	600	\$ 6.00	\$ 3,600.00
8	416104	MINOR PAVING TYPE I, HMA SP-IV	TON	400	\$ 165.00	\$ 66,000.00
9	515000	REINFORCED CONCRETE FOR MINOR STRUCTURES	C.Y.	4	\$ 1,500.00	\$ 6,000.00

10	570461	CULVERT PIPE	L.F.	47	\$ 250.00	\$ 11,750.00
11	570465	CULVERT PIPE END SECTION	EACH	1	\$ 900.00	\$ 900.00
12	601000	REMOVAL OF STRUCTURES AND OBSTRUCTIONS	LS	1	\$ 12,000.00	\$ 12,000.00
13	601110	REMOVAL OF SURFACING	S.Y.	1,150	\$ 12.00	\$ 13,800.00
14	602000	RIPRAP CLASS A	C.Y.	17	\$ 500.00	\$ 8,500.00
15	602060	RIPRAP CLASS G	S.Y.	17	\$ 250.00	\$ 4,250.00
16	609424	CONCRETE VERTICAL CURB AND GUTTER 6" X 24"	L.F.	112	\$ 80.00	\$ 8,960.00
17	613000	CLEANING CULVERTS AND DRAINAGE STRUCTURES	LS	1	\$ 6,500.00	\$ 6,500.00
18	618000	TRAFFIC CONTROL MANAGEMENT	LS	1	\$ 5,000.00	\$ 5,000.00
19	618011	PUBLIC AWARENESS	LS	1	\$ 1,500.00	\$ 1,500.00
20	621000	MOBILIZATION	LS	1	\$ 30,000.00	\$ 30,000.00
21	801000	CONSTRUCTION STAKING BY CONTRACTOR	LS	1	\$ 15,000.00	\$ 15,000.00
22	802000	POST CONSTRUCTION PLANS	LS	1	\$ 3,000.00	\$ 3,000.00

Write out Base Bid Amount:

Two hundred thirty one thousand one hundred ten dollars

a) **Base Bid** Subtotal of Bid Items No. 1 through 22 \$ 231,110

b) **Allowances: \$10,000**

\$ 10,000.00

Total Allowances: \$ 10,000.00

c) **Subtotal** Base Bid subtotal plus Allowances: \$ 241,110

d) **New Mexico Gross Receipts Tax (NMGRT)**

on amount online c) Subtotal at 8.3000%:

\$ 20,012.13

e) **BASE BID TOTAL** Line c) Subtotal plus Line d) NMGRT: \$ 261,122.13

Two hundred sixty one thousand one hundred twenty two dollars and 13/100 — Dollars (Total amount written in words)

**DHSEM PROJECTS BID PROPOSAL
NON-PARTICIPATING BID**

BID ITEM	NMDOT ITEM NO.	ITEM DESCRIPTION	UNIT	ESTIMATED QTY	UNIT PRICE	AMOUNT
BASE BID LOT						
1	662400	MANHOLE ADJUSTMENT	EACH	1	\$ 2,000.00	\$ 2,000.00
2	663850	WATER VALVE ADJUSTMENT	EACH	1	\$ 10,000.00	\$ 1,000.00

Write out Base Bid Amount:

Three thousand dollars

a) Non-Participating Bid Subtotal of Bid Items No. 1 through 2 \$ 3,000

b) Allowances:

\$ 0.00 _____

Total Allowances: \$ 0.00

c) Subtotal Base Bid subtotal plus Allowances: \$ 3,000

d) New Mexico Gross Receipts Tax (NMGRT)

on amount online c) Subtotal at 8.3000%: \$ 249

e) BASE BID TOTAL Line c) Subtotal plus Line d) NMGRT: \$ 3,249.00

Three thousand two hundred forty nine

Dollars (Total amount written in words)

The undersigned, as Bidder, hereby declares that the only persons or firms interested in the proposal as principals are named herein; that no other persons or firms have any interest in this proposal or in the contract to be entered into; that this proposal is made without collusion with any other person, company, or parties making a bid; and that it is in all respects fair and in good faith, 60 calendar days

The Contractor agrees that should he fail to complete the project in _____, he agrees to pay as liquidated damages the amount of three hundred dollars (\$300.00) per calendar day for each day exceeding the contract substantial completion date, representing monetary damage and risk to property or life. The Contractor further agrees that any extensions in the contract time shall apply only to the date of completion for the entire contract.

CITY OF RIO COMMUNITIES DHSEM PROJECTS



VALENCIA COUNTY, NEW MEXICO
CITY PROJECT NO. 2021-040-002

INDEX OF SHEETS		
SHEET NUMBER	DESCRIPTION	REV. DATE
SECTION-1		
1 - 1	COVER, SHEET INDEX AND VICINITY MAP	
1 - 2	SUMMARY OF QUANTITIES	
1 - 3	GENERAL NOTES	
SUBTOTAL: 3		
SECTION-2		
2 - 1	EXISTING TYPICAL SECTIONS	
2 - 2	PROPOSED TYPICAL SECTIONS	
2 - 3	SURFACING SCHEDULE	
2 - 4	MISCELLANEOUS QUANTITIES & ESTIMATED STRUCTURE QUANTITIES	
SUBTOTAL: 4		
SECTION-3		
3 - 1 TO 3 - 3	HORIZONTAL LAYOUT PLAN	
3 - 4	SURVEY CONTROL MAP	
SUBTOTAL: 4		
SECTION-4		
	NO SHEETS	
SUBTOTAL: 0		
SECTION-5		
	NO SHEETS	
SUBTOTAL: 0		
SECTION-6		
	NO SHEETS	
SUBTOTAL: 0		
SECTION-7		
	NO SHEETS	
SUBTOTAL: 0		
SECTION-8		
	NO SHEETS	
SUBTOTAL: 0		

INDEX OF SHEETS		
SHEET NUMBER	DESCRIPTION	REV. DATE
SECTION-9		
	NO SHEETS	
SUBTOTAL: 0		
SECTION-10		
10 - 1 TO 10 - 7	PERMANENT DRAINAGE PLAN	
10 - 8	STORM DRAIN SPILLWAY PLAN AND PROFILE	
SUBTOTAL: 8		
SECTION-11		
	NO SHEETS	
SUBTOTAL: 0		
SECTION-12		
	NO SHEETS	
SUBTOTAL: 0		
SECTION-13		
	NO SHEETS	
SUBTOTAL: 0		
SECTION-14		
	NO SHEETS	
SUBTOTAL: 0		
TOTAL: 19		

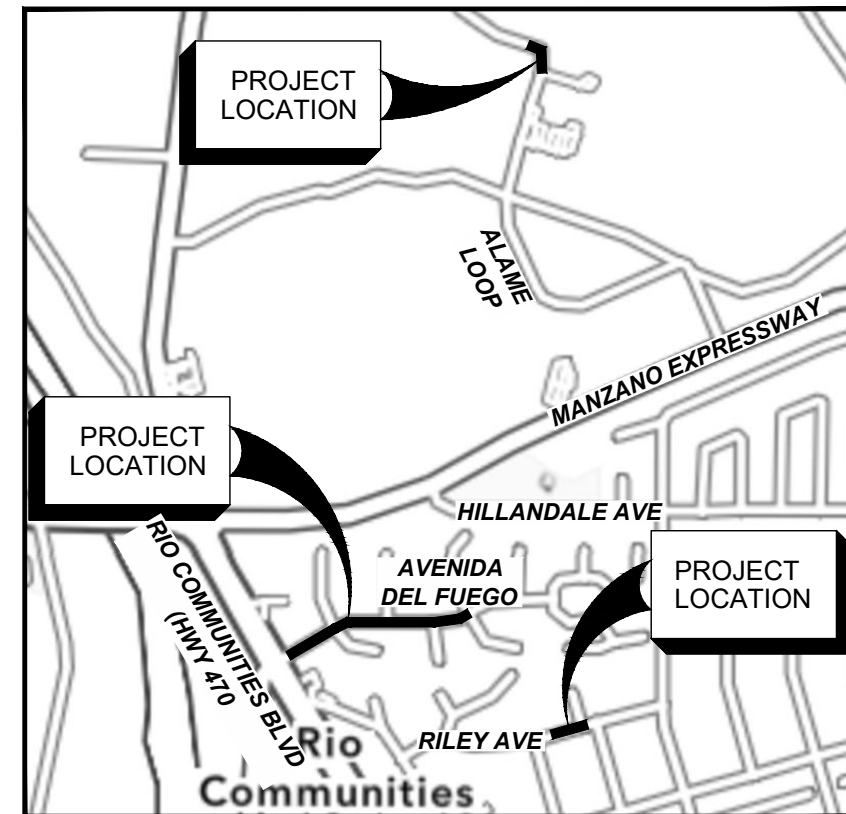

VICINITY MAP



CALL NM ONE-CALL
SYSTEM SEVEN (7) DAYS
PRIOR TO ANY EXCAVATION



2155 LOUISIANA BLVD NE,
SUITE 3000
ALBUQUERQUE, NM 87110
(505) 830-5400

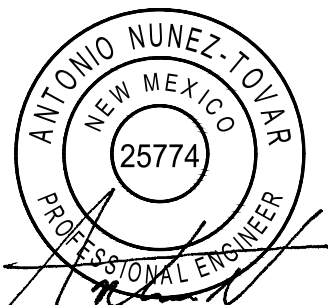

AUG 28, 2023

DATE: 28 Aug 2023 - 4:26pm USER: ANGONZALEZ



CITY OF RIO COMMUNITIES

SUMMARY OF QUANTITIES										
NMDOT ITEM NO.	SHORT DESCRIPTION	UNIT	ROADWAY		CONSTRUCTION ENGINEERING		DRAINAGE		PROJECT TOTAL	
			ESTIMATE	FINAL	ESTIMATE	FINAL	ESTIMATE	FINAL	ESTIMATE	FINAL
201000	CLEARING AND GRUBBING	LS	LS							LS
203000	UNCLASSIFIED EXCAVATION	C.Y.	230							230
203100	BORROW	C.Y.	40							40
207000	SUBGRADE PREPARATION	S.Y.	1,500							1,500
407000	ASPHALT MATERIAL FOR TACK COAT	TON	1							1
408100	PRIME COAT MATERIAL	TON	3							3
414000	COLD MILLING (ASPHALT)	SYIN	600							600
416104	MINOR PAVING TYPE I, HMA SP-IV	TON	400							400
515000	REINF. CONCRETE FOR MINOR STRUCTURES	C.Y.					4			4
570461	36" STORM DRAIN CULVERT PIPE	L.F.					47			47
570465	36" STORM DRAIN CULVERT PIPE END SECTION	EACH					1			1
601000	REMOVAL OF STRUCTURES AND OBSTRUCTIONS	LS	LS							LS
601110	REMOVAL OF SURFACING	S.Y.	1,150							1,150
602000	RIPRAP CLASS A	C.Y.					17			17
602060	RIPRAP CLASS G	S.Y.					17			17
609424	CONCRETE VERTICAL CURB AND GUTTER TYPE B 6" X 24"	L.F.	112							112
613000	CLEANING CULVERTS AND DRAINAGE STRUCTURES	LS	LS							LS
618000	TRAFFIC CONTROL MANAGEMENT	LS				LS				LS
618011	PUBLIC AWARENESS	LS				LS				LS
621000	MOBILIZATION	LS	LS							LS
801000	CONSTRUCTION STAKING BY THE CONTRACTOR	LS				LS				LS
802000	POST CONSTRUCTION PLANS	LS				LS				LS

SUMMARY OF QUANTITIES - NON PARTICIPATING						
NMDOT ITEM NO.	SHORT DESCRIPTION	UNIT	ROADWAY		PROJECT TOTAL	
			ESTIMATE	FINAL	ESTIMATE	FINAL
662400	MANHOLE ADJUSTMENT	EACH	1		1	
663850	WATER VALVE ADJUSTMENT	EACH	1		1	

NO.	DESCRIPTION	DATE	BY
4			
3			
2			
1			



CN 2021-040-002
DHSEM PROJECTS
SUMMARY OF QUANTITIES

DATE: 28 Aug 2023 - 4:26pm USER: ANGONZALEZ

GENERAL NOTES

1. **SPECIFICATIONS** : ALL WORK DETAILED ON THESE PLANS TO BE PERFORMED UNDER CONTRACT, EXCEPT AS OTHERWISE STATED OR PROVIDED FOR HEREON, SHALL BE CONSTRUCTED IN ACCORDANCE WITH THE NEW MEXICO DEPARTMENT OF TRANSPORTATION (NMDOT) STANDARD SPECIFICATIONS FOR HIGHWAY AND BRIDGE CONSTRUCTION, 2019 EDITION.
2. **GENERAL** : THE CONTRACTOR SHALL ABIDE BY ALL LOCAL, STATE, AND FEDERAL LAWS, RULES AND REGULATIONS WHICH APPLY TO THE CONSTRUCTION OF THESE IMPROVEMENTS.
3. **RESIDENCE ACCESS** : THE CONTRACTOR SHALL PROVIDE INGRESS AND EGRESS TO LOCAL RESIDENCES FOR THE DURATION OF THE PROJECT. THE CONTRACTOR SHALL ADVISE OF AND SCHEDULE ACCESS CLOSURES AT LEAST 24 HOURS IN ADVANCE, WITH PROPERTY OWNERS AND THE CITY MANAGER. THIS WORK WILL BE CONSIDERED INCIDENTAL TO ITEM NO. 618000 TRAFFIC CONTROL MANAGEMENT.
4. **CONSTRUCTION SCHEDULE** : TEN (10) WORKING DAYS PRIOR TO BEGINNING CONSTRUCTION, THE CONTRACTOR SHALL SUBMIT TO THE CITY OF RIO COMMUNITIES (CITY) A DETAILED CONSTRUCTION SCHEDULE.
5. THE CONTRACTOR SHALL NOT BEGIN WORK BEFORE 7:00 A.M. NOR CONTINUE WORK AFTER 6:00 P.M. WITHOUT THE APPROVAL OF THE CITY MANAGER.
6. **NM ONE-CALL**: TWO (2) WORKING DAYS PRIOR TO ANY EXCAVATION, THE CONTRACTOR SHALL CONTACT THE NEW MEXICO ONE CALL SYSTEM (505-260-1990) FOR LOCATION OF EXISTING UTILITIES.
7. **PERMITS** : THE CONTRACTOR SHALL OBTAIN ALL THE NECESSARY PERMITS FOR THE PROJECT PRIOR TO COMMENCING CONSTRUCTION.
8. **OVERNIGHT PARKING** : OVERNIGHT PARKING OF CONSTRUCTION EQUIPMENT SHALL NOT OBSTRUCT DRIVEWAYS OR DESIGNATED TRAFFIC LANES. THE CONTRACTOR SHALL NOT STORE ANY EQUIPMENT OR MATERIAL WITHIN THE PUBLIC RIGHT-OF-WAY.
9. **SURVEY MONUMENTS** : THE CONTRACTOR SHALL NOTIFY THE CITY NOT LESS THAN SEVEN (7) DAYS PRIOR TO STARTING WORK IN ORDER THAT THE CITY MAY TAKE NECESSARY MEASURES TO ENSURE THE PRESERVATION OF SURVEY MONUMENTS. CONTRACTOR SHALL NOT DISTURB PERMANENT SURVEY MONUMENTS WITHOUT THE CONSENT OF THE CITY AND SHALL NOTIFY THE CITY AND BEAR THE EXPENSE OF REPLACING ANY THAT MAY BE DISTURBED WITHOUT PERMISSION. WHEN A CHANGE IS MADE IN THE FINISHED ELEVATION OF THE PAVEMENT OF ANY ROADWAY IN WHICH A PERMANENT SURVEY MONUMENT IS LOCATED, CONTRACTOR SHALL, AT HIS OWN EXPENSE, ADJUST THE MONUMENT COVER TO THE NEW GRADE UNLESS OTHERWISE SPECIFIED.
10. **CONSTRUCTION LIMITS** : CONSTRUCTION ACTIVITY SHALL BE LIMITED TO THE PUBLIC RIGHT-OF-WAY AND/OR PROJECT LIMITS. ANY DAMAGE TO ADJACENT PROPERTIES RESULTING FROM THE CONSTRUCTION PROCESS IS THE RESPONSIBILITY OF THE CONTRACTOR. ANY COSTS INCURRED FOR REPAIRS SHALL BE AT THE COST OF THE CONTRACTOR.
11. **BUILDING DAMAGE** : IT SHALL BE THE CONTRACTOR'S RESPONSIBILITY TO ENSURE THAT BUILDING STRUCTURES ADJACENT TO THE PROJECT NOT BE DAMAGED DUE TO ANY CONSTRUCTION ACTIVITIES. DAMAGE CAUSED TO ANY BUILDING STRUCTURE WILL BE THE SOLE RESPONSIBILITY OF THE CONTRACTOR, INCLUDING ALL COSTS INCURRED IN RESTORING/REPAIRING SAID DAMAGE.
12. **AS-BUILTS** : THE CONTRACTOR SHALL MAINTAIN AN UP TO DATE SET OF AS-BUILT PLANS FOR THE PROJECT. THESE PLANS SHALL BE KEPT CURRENT, WITHIN TWO WEEKS, AT ALL TIMES AND SHALL BE SUBJECT TO THE REVIEW BY THE PROJECT MANAGER THROUGHOUT THE PROJECT AND WILL BE REVIEWED BY THE PROJECT MANAGER FOR ACCURACY AND COMPLETENESS AT LEAST ONCE EVERY 30 DAYS. THE FINAL AS-BUILT PLANS SHALL BE SUBMITTED AND ACCEPTED BY THE PROJECT ENGINEER PRIOR TO FINAL PAYMENT. AS-BUILT PLANS SHALL BE INCIDENTAL TO ITEM NO. 802000 POST CONSTRUCTION PLANS.
13. **GRAFFITI** : THE CONTRACTOR SHALL MAINTAIN A GRAFFITI-FREE WORK SITE AND SHALL PROMPTLY REMOVE ANY AND ALL GRAFFITI FROM ALL EQUIPMENT, FACILITIES, APPURTENANCES, AND ANY AND ALL BARRICADING AND SIGNAGE ASSOCIATED WITH THE PROJECT WHETHER PERMANENT OR TEMPORARY. THIS WORK SHALL BE CONSIDERED INCIDENTAL TO THE PROJECT AND NO SEPARATE MEASUREMENT OR PAYMENT WILL BE MADE THEREFOR. THIS WORK WILL BE CONSIDERED INCIDENTAL TO ITEM NO. 618000 TRAFFIC CONTROL MANAGEMENT.
14. **CONSTRUCTION SIGNAGE** : THE CONTRACTOR SHALL BE RESPONSIBLE FOR PROVIDING AND MAINTAINING ALL CONSTRUCTION SIGNAGE UNTIL THE PROJECT HAS BEEN ACCEPTED BY THE CITY OF RIO COMMUNITIES.
15. **NON-VIBRATORY ROLLER** : THE CONTRACTOR SHALL BE RESTRICTED TO THE USE OF A 35 TON MAXIMUM NON-VIBRATORY ROLLER TO OBTAIN THE REQUIRED COMPACTION IN PAVEMENT STRUCTURE, ROADWAY BACKFILL, EMBANKMENT, AND SUBGRADES IN RESIDENTIAL AREAS WHERE THE USE OF HEAVIER EQUIPMENT COULD DAMAGE UNDERGROUND UTILITIES OR OTHER PERMANENT STRUCTURES.
16. **EXISTING TIE-IN** : ALL NEW STREET PAVING, CURB AND GUTTER, SIDEWALKS OR DRIVEPADS SHALL MATCH THE ELEVATIONS OF ABUTTING EXISTING AREAS AS SHOWN IN THE PLANS OR AS DIRECTED BY THE PROJECT MANAGER.
17. **DAMAGE REPAIR** : THE CONTRACTOR SHALL ASSUME RESPONSIBILITY FOR ANY DAMAGE TO EXISTING PAVEMENTS, PAVEMENT MARKINGS, CURB & GUTTER, DRIVE PADS, CURB RAMPS, SIGNAGE, AND SIDEWALK DURING CONSTRUCTION, APART FROM THOSE SECTIONS INDICATED FOR REMOVAL ON THE PLANS AND SHALL REPAIR OR REPLACE PER NMDOT STANDARDS, AT THEIR OWN EXPENSE.
18. **OSHA REQUIREMENTS** : ALL EXCAVATION, TRENCHING, AND SHORING ACTIVITIES MUST BE CARRIED-OUT IN ACCORDANCE WITH OSHA 29 CFR 1926.652.
19. **MATCHING EXISTING GRADES** : WHERE A PROFILE GRADE IS NOT PROVIDED IN THE PLANS, STREET CENTERLINE GRADES SHALL BE RESTORED BY THE CONTRACTOR TO THE EXISTING CENTERLINE GRADES. CROSS SECTION THE EXISTING ROAD PRIOR TO CONSTRUCTION AS NEEDED TO MATCH EXISTING (50' MIN). MINOR ADJUSTMENTS TO THE STREET GRADES MAY BE NECESSARY AND WILL BE DIRECTED BY THE PROJECT ENGINEER. MINOR ADJUSTMENTS TO THE STREET GRADES WILL BE CONSIDERED INCIDENTAL TO THE PAVING BID ITEMS. SMOOTH TRANSITIONS SHALL BE MADE BETWEEN EXISTING PAVEMENT WHICH REMAINS IN PLACE AND PAVEMENT WHICH IS BEING REPLACED. TRAFFIC CONTROL DEVICES INCLUDING PAVEMENT MARKINGS MUST BE RESTORED TO THE SAME OR BETTER CONDITION AS BEFORE CONSTRUCTION. THIS WORK WILL BE CONSIDERED INCIDENTAL TO ITEM NO. 416104 MINOR PAVING TYPE I, HMA SP-IV.
20. **HUMAN REMAINS** : IF HUMAN REMAINS ARE ENCOUNTERED, THE CONTRACTOR SHALL CEASE ALL WORK, AND NOTIFY THE CITY OF RIO COMMUNITIES FOR FURTHER INSTRUCTIONS.
21. **DROP-OFF POLICY** : IF A PAVEMENT DROP-OFF IS CREATED DURING CONSTRUCTION, THE CONTRACTOR SHALL INITIATE PROTECTIVE ACTION TO MAINTAIN A SMOOTH TRANSITION. THIS WORK SHALL BE CONSIDERED INCIDENTAL TO ITEM NO. 618000 TRAFFIC CONTROL MANAGEMENT, AND NO SEPARATE MEASUREMENT OR PAYMENT WILL BE MADE THEREFOR.
22. **PUBLIC INFORMATION** : COORDINATION WITH THE CITY PUBLIC INFORMATION OFFICE (PIO), WHO WILL ADVISE THE PUBLIC OF CONSTRUCTION FOR THE DURATION OF THE PROJECT. ANY IMPACT TO THE ACCESS OF BUSINESSES SHALL BE COORDINATED SEVEN (7) DAYS IN ADVANCE WITH THE CITY AND BUSINESSES.
23. **UTILITY REPAIR** : THE CONTRACTOR IS RESPONSIBLE FOR PROTECTING THE EXISTING UTILITY LINES WITHIN THE CONSTRUCTION AREA. ANY DAMAGE TO EXISTING FACILITIES CAUSED BY CONSTRUCTION ACTIVITY SHALL BE REPAIRED OR REPLACED AT THE CONTRACTOR'S EXPENSE AND APPROVED BY THE CITY.
24. ALL ELECTRICAL, TELEPHONE, CABLE TV, GAS AND OTHER UTILITY LINES, CABLES AND APPURTENANCES ENCOUNTERED DURING CONSTRUCTION THAT REQUIRE RELOCATION, SHALL BE COORDINATED WITH THAT UTILITY. THE CONTRACTOR SHALL BE RESPONSIBLE FOR COORDINATION OF ALL NECESSARY UTILITY ADJUSTMENTS. NO ADDITIONAL COMPENSATION WILL BE ALLOWED FOR DELAYS OR INCONVENIENCES CAUSED BY UTILITY COMPANY WORK CREWS. THE CONTRACTOR MAY BE REQUIRED TO RESCHEDULE THEIR ACTIVITIES TO ALLOW UTILITY CREWS TO PERFORM THEIR REQUIRED WORK.
25. **DISPOSAL SITE** FOR ALL EXCESS EXCAVATION MATERIAL, AND UNSUITABLE MATERIAL SHALL BE OBTAINED BY THE CONTRACTOR IN COMPLIANCE WITH APPLICABLE ENVIRONMENTAL REGULATIONS AND APPROVED BY THE CITY. ALL COSTS INCURRED IN OBTAINING A DISPOSAL SITE AND HAUL THERETO SHALL BE CONSIDERED INCIDENTAL TO ITEM NO. 203000 UNCLASSIFIED EXCAVATION, AND NO SEPARATE MEASUREMENT OR PAYMENT WILL BE MADE.
26. THE CONTRACTOR SHALL COORDINATE WITH THE CITY PRIOR TO BEGINNING ANY CONSTRUCTION WORK ON OR ADJACENT TO EXISTING STREETS.
27. ALL BARRICADES AND CONSTRUCTION SIGNING SHALL CONFORM TO APPLICABLE SECTIONS OF THE "MANUAL ON UNIFORM TRAFFIC CONTROL DEVICES" (MUTCD), U.S. DEPARTMENT OF TRANSPORTATION, LATEST EDITION.
28. THE CONTRACTOR SHALL MAINTAIN ALL CONSTRUCTION BARRICADES AND SIGNING AT ALL TIMES. THE CONTRACTOR SHALL VERIFY THE PROPER LOCATION OF ALL BARRICADING AT THE END AND BEGINNING OF EACH DAY.
29. ALL SAWCUT PAVEMENT SHALL HAVE A UNIFORM EDGE AND BE SPRAYED WITH TACK COAT. THIS WORK WILL BE CONSIDERED INCIDENTAL TO ITEM NO. 416104 MINOR PAVING TYPE I, HMA SP-IV.
30. PRIOR TO CONSTRUCTION, THE CONTRACTOR SHALL EXCAVATE AND VERIFY THE HORIZONTAL AND VERTICAL LOCATIONS OF ALL POTENTIAL OBSTRUCTIONS. SHOULD A CONFLICT EXIST, THE CONTRACTOR SHALL NOTIFY THE CITY INSPECTOR IMMEDIATELY SO THE CONFLICT CAN BE RESOLVED WITH A MINIMUM AMOUNT OF DELAY.
31. IF THE CONTRACTOR IS NOT ALLOWED TO WORK AT NIGHT DUE TO THE CITY'S NOISE ORDINANCE, THE CONTRACTOR SHALL OPEN ALL TRAFFIC LANES TO TRAFFIC WITH PROPER USE OF TRENCH PLATES DURING NON-WORKING HOURS, UNLESS PERMITTED BY CONSTRUCTION PROJECT MANAGER.
32. THE CONTRACTOR SHALL RECORD DATA ON ALL UTILITY LINES AND ACCESSORIES AS REQUIRED BY THE CITY FOR THE PREPARATION OF "AS-BUILT" DRAWINGS. CONTRACTOR SHALL NOT COVER UTILITY LINES AND ACCESSORIES UNTIL ALL DATA HAS BEEN RECORDED.
33. **SALVAGEABLE MATERIALS** : SALVAGEABLE MATERIALS FROM THIS PROJECT ARE TO BE HAULED AND STOCKPILED AT THE CITY PROPERTY INDICATED BY THE CITY MANAGER. HAUL OF SUCH MATERIAL SHALL BE PERFORMED DURING NORMAL WORKING HOURS AS DIRECTED BY THE PROJECT MANAGER. PAYMENT FOR THIS WORK WILL BE CONSIDERED INCIDENTAL TO ITEM NO. 201000 CLEARING AND GRUBBING.
34. **ADJACENT LANDSCAPING** TO BE PROTECTED BY THE CONTRACTOR AND NO SEPARATE PAYMENT WILL BE MADE. CONTRACTOR SHALL TAKE VIDEO AND PHOTOS OF ALL EXISTING LANDSCAPING. DAMAGE TO EXISTING LANDSCAPING SHALL BE REPLACED IN KIND BY CONTRACTOR WITH NO SEPARATE PAYMENT.
35. IF EXISTING FIBER OPTIC OR ANY OTHER EXISTING CITY TRAFFIC INFRASTRUCTURE IS DAMAGED AS PART OF THIS PROJECT WORK, THE CONTRACTOR SHALL REPAIR IT OR REPLACE IT PER CITY TRAFFIC REQUIREMENTS. DAMAGED FIBER OPTIC CABLE SHALL BE REPLACED FROM EXISTING FULL SPLICE TO EXISTING FULL SPLICE; NO INTERMEDIATE SPLICE WILL BE ALLOWED. THIS WORK SHALL BE DONE AT THE EXPENSE OF THE CONTRACTOR AND NO ADDITIONAL PAYMENT WILL BE MADE.
36. AT ALL PAVEMENT REMOVAL AND REPLACEMENTS, SAW-CUT EDGES SHALL BE STRAIGHT AND CLEAN, AND LONGITUDINAL JOINTS SHALL NOT BE PLACED WITHIN WHEEL PATHS. PATCHES SHALL BE REGULAR AND SQUARE OR RECTANGULAR, WITH FOUR STRAIGHT SIDES. FINISHED PAVEMENT SURFACE SHALL BE FLUSH WITH EXISTING PAVEMENT SURFACE, WITH NO SPILLOVER OF ASPHALT OR TACK COAT. CARE MUST BE TAKEN TO AVOID DAMAGING THE INTEGRITY OR APPEARANCE OF SURROUNDING PAVEMENTS; IF DAMAGED, THE ENTIRE SURFACE PATCH MUST BE EXPANDED TO COVER DAMAGES AT THE CONTRACTOR'S EXPENSE.
37. THE CONTRACTOR SHALL DESIGNATE AT LEAST ONE EMERGENCY CONTACT PERSON, AND SHALL PROVIDE TELEPHONE NUMBERS WHERE THIS PERSON CAN BE CONTACTED AT ANY TIME. THIS INFORMATION SHALL BE PROVIDED TO THE CITY'S PROJECT MANAGER.
38. THE CONTRACTOR SHALL SUBMIT A TRAFFIC CONTROL PLAN FOR WORK WITHIN THE PUBLIC RIGHT-OF-WAY SHOWING ALL TEMPORARY TRAFFIC CONTROL DEVICES FOR EACH PHASE OF WORK. THE PLAN SHALL SHOW EACH INDIVIDUAL PHASE OF THE PROJECT WITH A SCHEDULE AND MAP SHOWING PLACEMENT AND DESCRIPTION OF EACH TEMPORARY TRAFFIC CONTROL DEVICE. THE "TRAFFIC CONTROL PLAN" SHALL COMPLY WITH THE MANUAL ON UNIFORM TRAFFIC CONTROL DEVICES. THIS WORK WILL BE CONSIDERED INCIDENTAL TO ITEM NO. 618000 TRAFFIC CONTROL MANAGEMENT.



CITY OF RIO COMMUNITIES

NO.	DESCRIPTION	DATE	BY
4			
3			
2			
1			
NO.			

CN 2021-040-002
DHSEM PROJECTS
GENERAL NOTES



DATE: 28 Aug 2023 - 4:26pm USER: ANGONZALEZ



CITY OF RIO COMMUNITIES

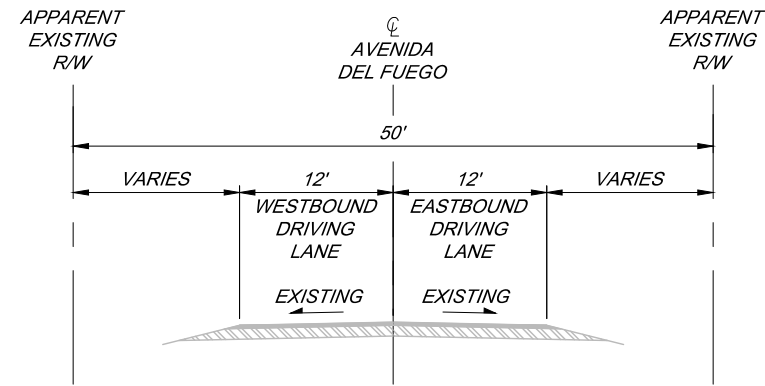

EXISTING TYPICAL SECTION 1 - AVENIDA DEL FUEGO
STA. 10+49.56 TO STA. 23+88.72

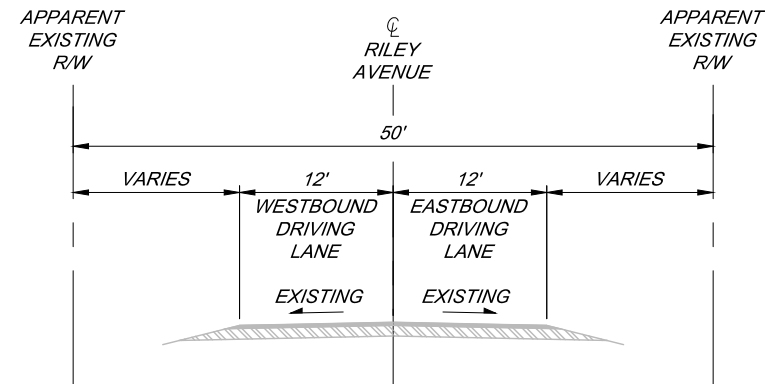
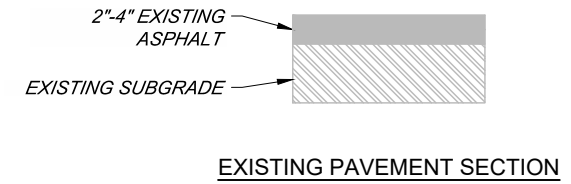

EXISTING TYPICAL SECTION 2 - RILEY AVENUE
STA. 50+54.59 TO STA. 52+23.60

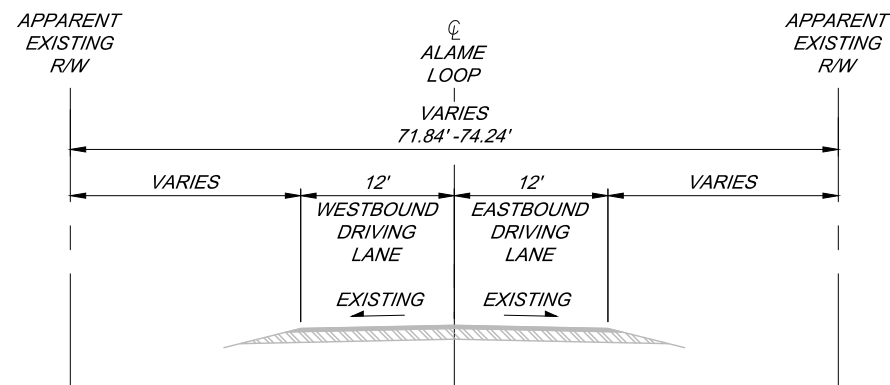

EXISTING TYPICAL SECTION 3 - ALAME LOOP
STA. 100+32.35 TO STA. 101+41.35

NO.	DESCRIPTION	DATE	BY
4			
3			
2			
1			

RIO COMMUNITIES
DHSEM PROJECTS
EXISTING TYPICAL SECTIONS



DATE: 28 Aug 2023 - 4:27 pm USER: ANGONZALEZ



CITY OF RIO COMMUNITIES

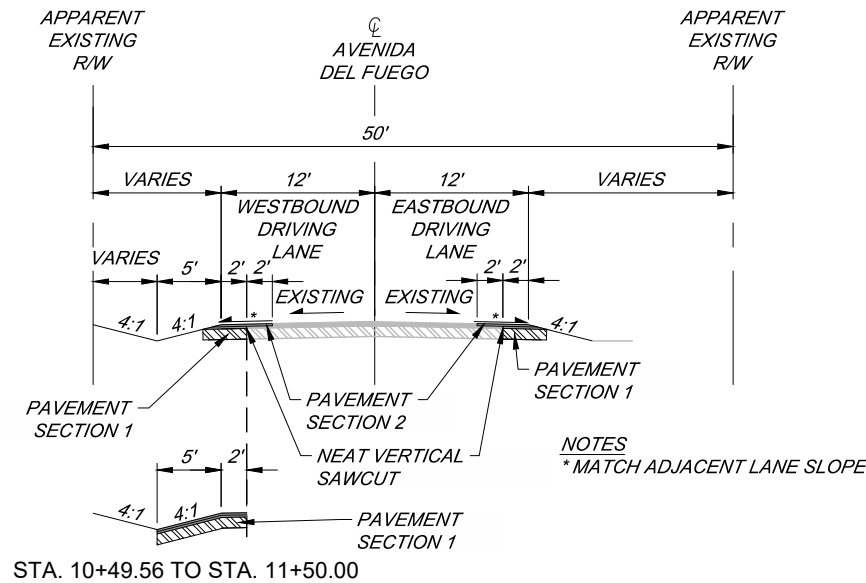

PROPOSED TYPICAL SECTION 1 - AVENIDA DEL FUEGO
STA. 10+49.56 TO STA. 14+82.27

TRANSITION
STA. 14+82.27 TO STA. 15+41.27 (LA LUNA PLACE)

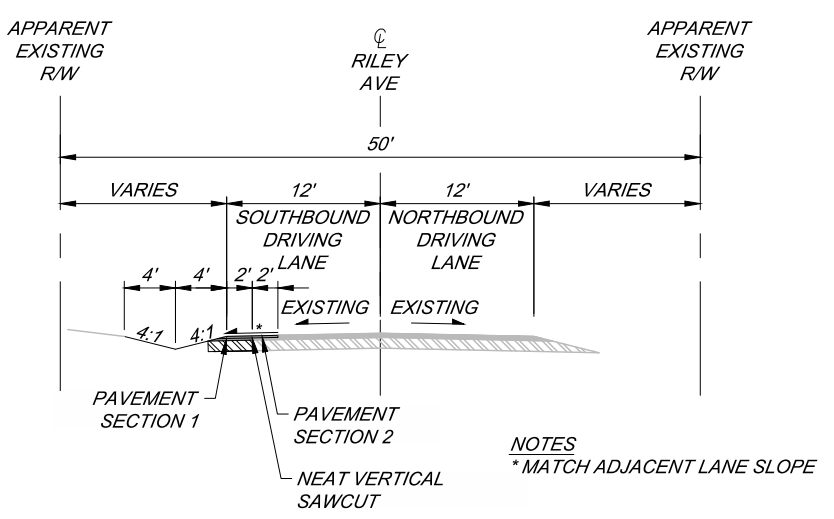

PROPOSED TYPICAL SECTION 3 - RILEY AVENUE
STA. 50+54.59 TO STA. 51+34.59

TRANSITION
STA. 51+34.59 TO STA. 52+23.60 (RILEY PLACE DRIVEWAY)

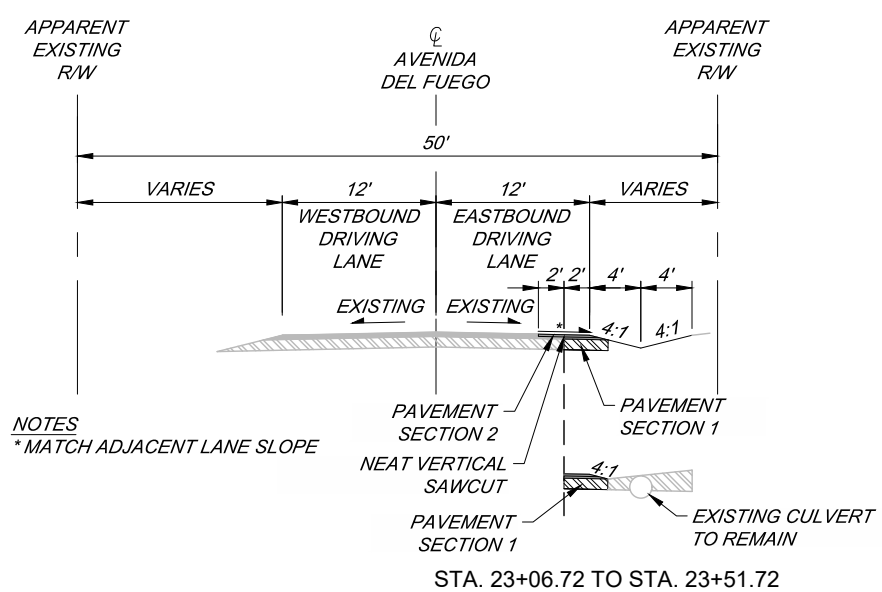
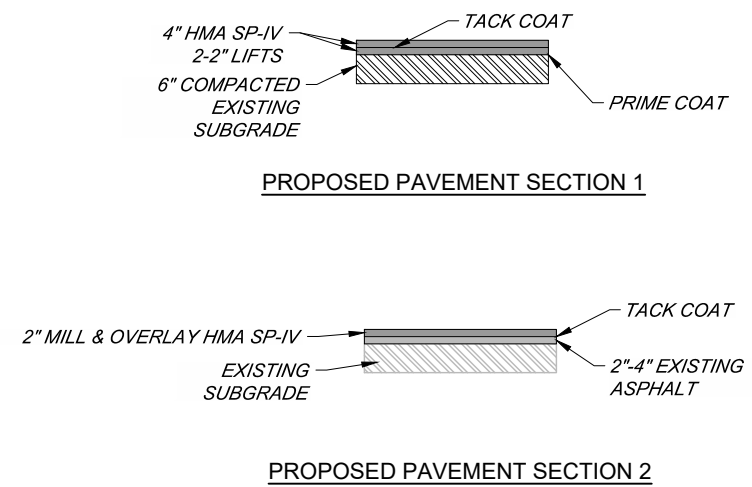

PROPOSED TYPICAL SECTION 2 - AVENIDA DEL FUEGO
STA. 22+83.72 TO STA. 23+83.72

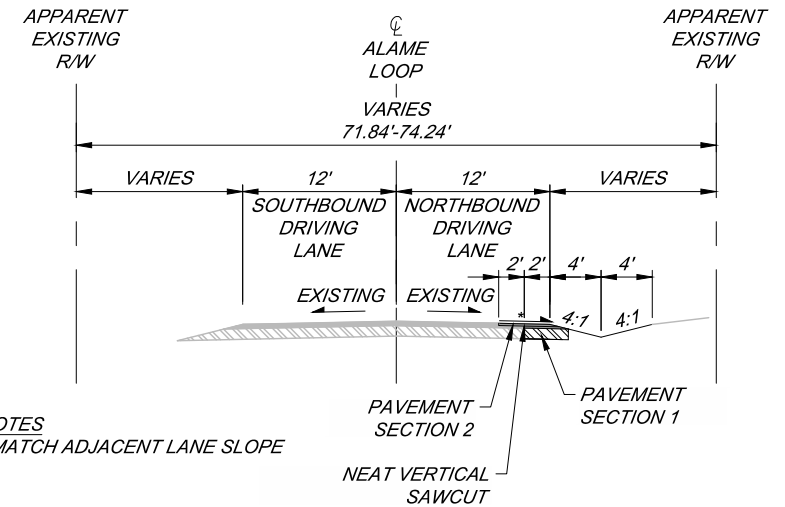

PROPOSED TYPICAL SECTION 4 - ALAME LOOP
STA. 100+32.35 TO STA. 101+41.35

NO.	DESCRIPTION	DATE	BY
4			
3			
2			
1			

RIO COMMUNITIES
DHSEM PROJECTS
PROPOSED TYPICAL SECTIONS



DATE: 28 Aug 2023 - 4:27 pm USER: ANGONZALEZ



CITY OF RIO COMMUNITIES

SURFACING SCHEDULE				207000			414000				416104				*	*	407000			408100		
				SUBGRADE PREPARATION			COLD MILLING (ASPHALT)				MINOR PAVEMENT TYPE I, HMA SP-IV				PG 76-22 ASPHALT MATERIAL	HYDRATE D LIME	ASPHALT MATERIAL FOR TACK COAT			PRIME COAT MATERIAL		
STATION TO STATION	LOCATION	DESCRIPTION	LENGTH (FT)	AVG. WIDTH (FT)	SY	AVG WIDTH (FT)	DEPTH (IN)	SY	SYIN	AVG WIDTH (FT)	DEPTH (IN)	SY	TON	TON	TON	AVG WIDTH (FT)	SY	TON	AVG WIDTH (FT)	SY	TON	
<i>ALIGNMENT: AVENIDA DEL FUEGO</i>																						
10+49.56	14+82.27	EB	PAVMENT SECTION 1	432.71	2.00	96.16				2.00	4.00	96.16	20.49	1.19	0.20	2.00	96.16	0.03	2.00	96.16	0.18	
10+49.56	15+41.27	EB	PAVEMENT SECTION 2	491.71			2.00	2.00	109.27	218.54	2.00	2.00	109.27	11.64	0.68	0.12	2.00	109.27	0.04			
10+49.56	14+82.27	EB	SURFACING TAPER	432.71	1.46	70.20				0.73	4.00	35.10	7.48	0.43	0.07	0.73	35.10	0.01	1.46	70.20	0.13	
10+49.56	11+50.00	WB	PAVMENT SECTION 1	100.44	7.00	78.12				7.00	4.00	78.12	16.65	0.97	0.17	7.00	78.12	0.03	7.00	78.12	0.15	
10+49.56	11+50.00	WB	PAVEMENT SECTION 2	100.44			2.00	2.00	22.32	44.64	2.00	2.00	22.32	2.38	0.14	0.02	2.00	22.32	0.01			
10+49.56	11+50.00	WB	SURFACING TAPER	100.44	1.46	16.29				0.73	4.00	8.15	1.74	0.10	0.02	0.73	8.15	0.00	1.46	16.29	0.03	
11+50.00	14+82.27	WB	PAVMENT SECTION 1	332.27	2.00	73.84				2.00	4.00	73.84	15.74	0.91	0.16	2.00	73.84	0.02	2.00	73.84	0.14	
11+50.00	14+82.27	WB	PAVEMENT SECTION 2	332.27			2.00	2.00	73.84	147.68	2.00	2.00	73.84	7.87	0.46	0.08	2.00	73.84	0.02			
11+50.00	14+82.27	WB	SURFACING TAPER	332.27	1.46	53.90				0.73	4.00	26.95	5.74	0.33	0.06	0.73	26.95	0.01	1.46	53.90	0.10	
14+82.27	15+41.27	EB	LA LUNA PLACE DRIVEWAY	59.00	CALC	95.84				CALC	4.00	95.84	20.43	1.18	0.20	CALC	95.84	0.03	CALC	95.84	0.18	
19+22.83	19+82.98	WB	ESTRELLA PLACE DRIVEWAY	60.15	CALC	85.56				CALC	4.00	85.56	18.23	1.06	0.18	CALC	85.56	0.03	CALC	85.56	0.16	
22+83.72	23+83.72	EB	PAVMENT SECTION 1	100.00	2.00	22.22				2.00	4.00	22.22	4.74	0.27	0.05	2.00	22.22	0.01	2.00	22.22	0.04	
22+83.72	23+83.72	EB	PAVEMENT SECTION 2	100.00	2.00	22.22	2.00	2.00	22.22	44.44	2.00	2.00	22.22	2.37	0.14	0.02	2.00	22.22	0.01			
22+83.72	23+83.72	EB	SURFACING TAPER	100.00	1.46	16.22				0.73	4.00	8.11	1.73	0.10	0.02	0.73	8.11	0.00	1.46	16.22	0.03	
<i>ALIGNMENT: RILEY AVE</i>																						
50+54.59	51+34.59	WB	PAVMENT SECTION 1	80.00	2.00	17.78				2.00	4.00	17.78	3.79	0.22	0.04	2.00	17.78	0.01	2.00	17.78	0.03	
50+54.59	52+23.60	WB	PAVEMENT SECTION 2	169.01			2.00	2.00	37.56	75.12	2.00	2.00	37.56	4.00	0.23	0.04	2.00	37.56	0.01			
50+54.59	51+34.59	WB	SURFACING TAPER	80.00	1.46	12.98				0.73	4.00	6.49	1.38	0.08	0.01	0.73	6.49	0.00	1.46	12.98	0.02	
51+34.59	52+23.60	WB	RILEY PLACE	89.01	CALC	144.01				CALC	4.00	144.01	30.69	1.78	0.31	CALC	144.01	0.05	CALC	144.01	0.27	
<i>ALIGNMENT: ALAME LOOP</i>																						
100+32.35	101+41.35	NB	PAVMENT SECTION 1	109.00	2.00	24.22				2.00	4.00	24.22	5.16	0.30	0.05	2.00	24.22	0.01	2.00	24.22	0.05	
100+32.35	101+41.35	NB	PAVEMENT SECTION 2	109.00			2.00	2.00	24.22	48.44	2.00	2.00	24.22	2.58	0.15	0.03	2.00	24.22	0.01			
100+32.35	101+41.35	NB	SURFACING TAPER	109.00	1.46	17.68				0.73	4.00	8.84	1.88	0.11	0.02	0.73	8.84	0.00	1.46	17.68	0.03	
<i>SAN LUCAS AVE</i>																						
			PAVMENT SECTION 1	136.17	36.00	544.67				36.00	4.00	544.67	116.07	6.73	1.16	36.00	544.67	0.18	36.00	544.67	1.02	
SUBTOTAL:						1,391.91			289.43	578.86			302.78	17.56	1.85			0.52			2.57	
TOTAL:						1,391.91			289.43	578.86			302.78	17.56	3.03			0.52			2.57	
USE:						1,500			300	600			310	20	4			1			3	

NOTES:

- AMOUNTS OF BITUMINOUS MATERIAL SHOWN ARE FOR ESTIMATING PURPOSES ONLY. CORRECT AMOUNTS WILL BE DETERMINED BY THE MATERIAL AND TESTING LABORATORY.
- * HYDRATED LIME AND PG 76-22 QUANTITIES ARE SHOWN FOR INFORMATION OF THE CONTRACTOR ONLY.

NO.	DESCRIPTION	DATE	BY
4			
3			
2			
1			

ESTIMATED SURFACING FACTORS						
ITEM	PG 76-22 HMA SP-IV % BY WT OF TOTAL MIX	TACK COAT SECT. 407 GAL/SY	PRIME COAT SECT. 408 GAL/SY	HYDRATED LIME	UNIT WEIGHT LBS/CY	GALLONS/TON
HOT MIX ASPHALT SP-IV	5.80% *			1.00% *	3836 **	
ASPHALT MATERIAL FOR TACK COAT		0.08 *				240
PRIME COAT MATERIAL			0.45 *			240
FOR CONTRACTORS INFORMATION ONLY.						
* FOR ESTIMATING PURPOSES ONLY, APPLICATION RATE WILL BE DETERMINED IN THE FIELD BY THE PROJECT MANAGER.						
** FOR ESTIMATING PURPOSES ONLY, ACTUAL WEIGHTS OR PERCENT SHALL BE DETERMINED BY APPROVED MIX DESIGN.						



CN 2021-040-002
DHSEM PROJECTS
SURFACING SCHEDULE

DATE: 28 Aug 2023 - 4:27 pm USER: ANGONZALEZ



CITY OF RIO COMMUNITIES

ESTIMATED STRUCTURE QUANTITIES										
SHEET NO.	STATION	STRUCTURE DESCRIPTION	515000	570461	570465	601000	602000	602060	613000	REMARKS
			REINF.CONC.FOR MINOR STRUCTURES	36" STORM DRAIN CULVERT PIPE	36" STORM DRAIN CULVERT PIPE END SECTION	REMOVAL OF STRUCTURES AND OBSTRUCTIONS	RIPRAP CLASS A	RIPRAP CLASS G	CLEANING CULVERTS AND DRAINAGE STRUCTURES	
			C.Y.	L.F.	EACH	LS	C.Y.	SQ.Y	LS	
10-8		FLUME AND RUNDOWN INCLUDING CONNECTION TO EXST. STORM DRAIN	3.8	47.0	1.0		16.9	16.9		
		PROJECT TOTAL	3.8	47.0	1.0	LS	16.9	16.9	LS	
		PROJECT USE	4	47	1	LS	17	17	LS	

EARTHWORK SUMMARY							
STATION	TO	STATION	203000 UNCLASSIFIED EXCAVATION (CU.YD.)	EMBANKMENT (CU.YD.)	203100 BORROW (CU. YD.)	EXCESS EXCAVATION (CU.YD.)	REMARKS
ALIGNMENT: AVENIDA DEL FUEGO							
10+49.56	-	14+82.27	32.05			32.05	
10+49.56	-	11+50.00	7.44			7.44	
11+50.00	-	14+82.27	24.61			24.61	
22+83.72	-	23+83.72	1.20			1.20	
14+82.27	-	15+41.27	31.95			31.95	
19+22.83	-	19+82.98	28.52			28.52	
		SUBTOTAL	125.77	SUBTOTAL	0.00	65.31	
ALIGNMENT: RILEY AVE							
50+54.59	-	51+34.59	5.93			5.93	
51+34.59	-	52+23.60	48.00			48.00	
		SUBTOTAL	53.93	SUBTOTAL	0.00	60.47	
ALIGNMENT: ALAME LOOP							
100+32.35	-	101+41.35	8.07			8.07	
		SUBTOTAL	8.07	SUBTOTAL	0.00	53.93	
SAN LUCAS AVE							
	-		32.40	32.4	32.40	0.00	
		SUBTOTAL	32.40	SUBTOTAL	32.40	0.00	
		TOTAL:	220.18		32.40		
		USE	230		40		

CONSTRUCTION ENGINEERING & LUMP SUM ITEMS		
NMDOT ITEM NO.	DESCRIPTION	UNITS
201000	CLEARING AND GRUBBING	LS
618000	TRAFFIC CONTROL MANAGEMENT	LS
618011	PUBLIC AWARENESS	LS
621000	MOBILIZATION	LS
801000	CONSTRUCTION STAKING BY THE CONTRACTOR	LS
802000	POST CONSTRUCTION PLANS	LS

- NOTES:**
- UNCLASSIFIED EXCAVATION QUANTITY DOES NOT INCLUDE REMOVAL OF SURFACING. REMOVAL OF SURFACING WILL BE PAID FOR UNDER ITEM 601110 "REMOVAL OF SURFACING."
 - NO CONSTRUCTION WASTE OR DEBRIS SHALL BE ALLOWED IN THE ROADWAY EMBANKMENT.
 - ROADWAY EMBANKMENT MATERIAL SHALL BE A-2-4 OR BETTER.

REMOVAL OF SURFACING ITEM NO. 601110								
STATION	TO	STATION	LENGTH (L.F.)	AVG. WIDTH (L.F.)	DEPTH (IN.)	AREA (S.Y.)		REMARKS
ALIGNMENT: AVENIDA DEL FUEGO								
10+49.56	-	14+82.27	432.71	2.00	4	96.16		EB
10+49.56	-	11+50.00	100.44	2.00	4	22.32		WB
11+50.00	-	14+82.27	332.27	2.00	4	73.84		WB
14+82.27	-	15+41.27			4	95.84		LA LUNA PLACE DRIVEWAY
19+22.83	-	19+82.98			4	85.56		ESTRELLA PLACE DRIVEWAY
22+83.72	-	23+83.72	100.00	2.00	4	22.22		EB
ALIGNMENT: RILEY AVE								
50+54.59	-	51+34.59	80.00	2.00	4	17.78		WB
51+34.59	-	52+23.60			4	144.01		RILEY PLACE
ALIGNMENT: ALAME LOOP								
100+32.35	-	101+41.35	109.00	2.00	4	24.22		NB
SAN LUCAS AVE								
					4	544.67		SAN LUCAS AND CHARMATIN INTERSECTION
					TOTAL	1,126.61		
					USE	1,150		

- NOTES:**
- INCLUDES ALL MATERIALS UP TO 4" DEEP FROM EXISTING GROUND SURFACE.

NO.	DESCRIPTION	DATE	BY
4			
3			
2			
1			



CN 2021-040-002
DHSEM PROJECTS
MISCELLANEOUS QUANTITIES & ESTIMATED
STRUCTURE QUANTITIES

DATE: 28 Aug 2023 - 4:27 pm USER: ANGONZALEZ

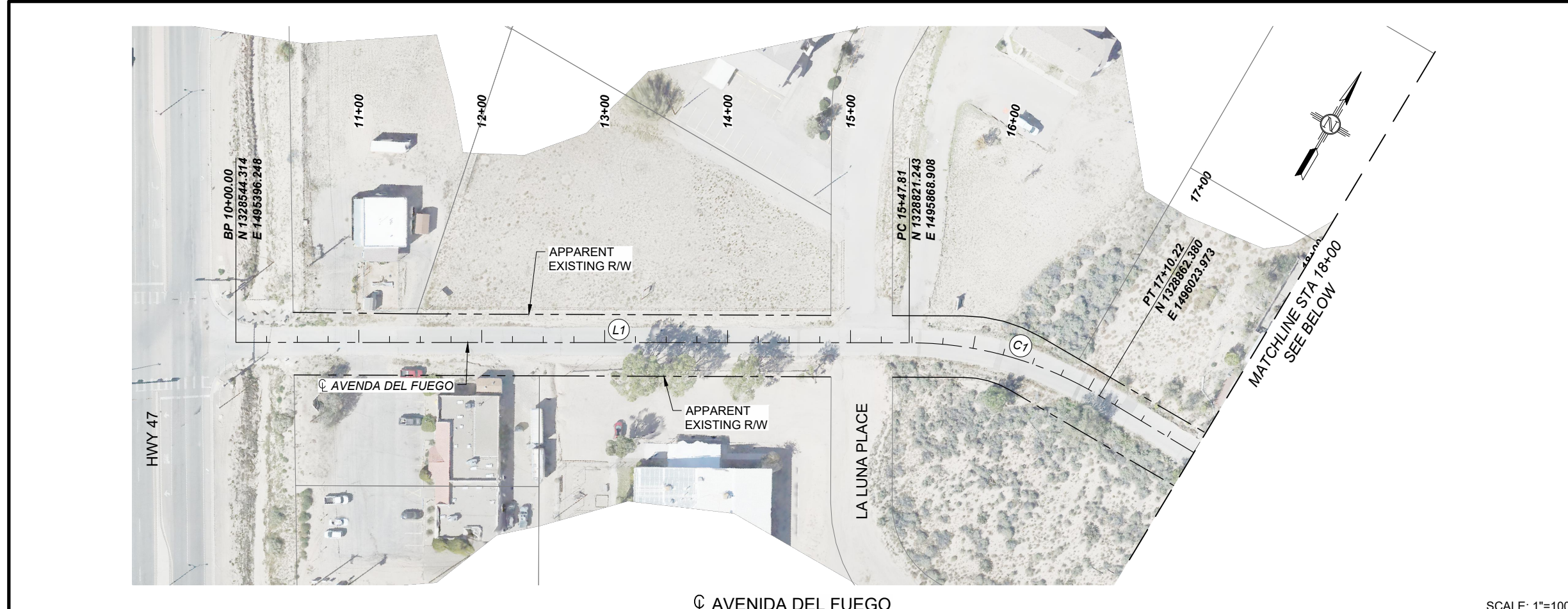

AVENIDA DEL FUEGO

SCALE: 1"=100'

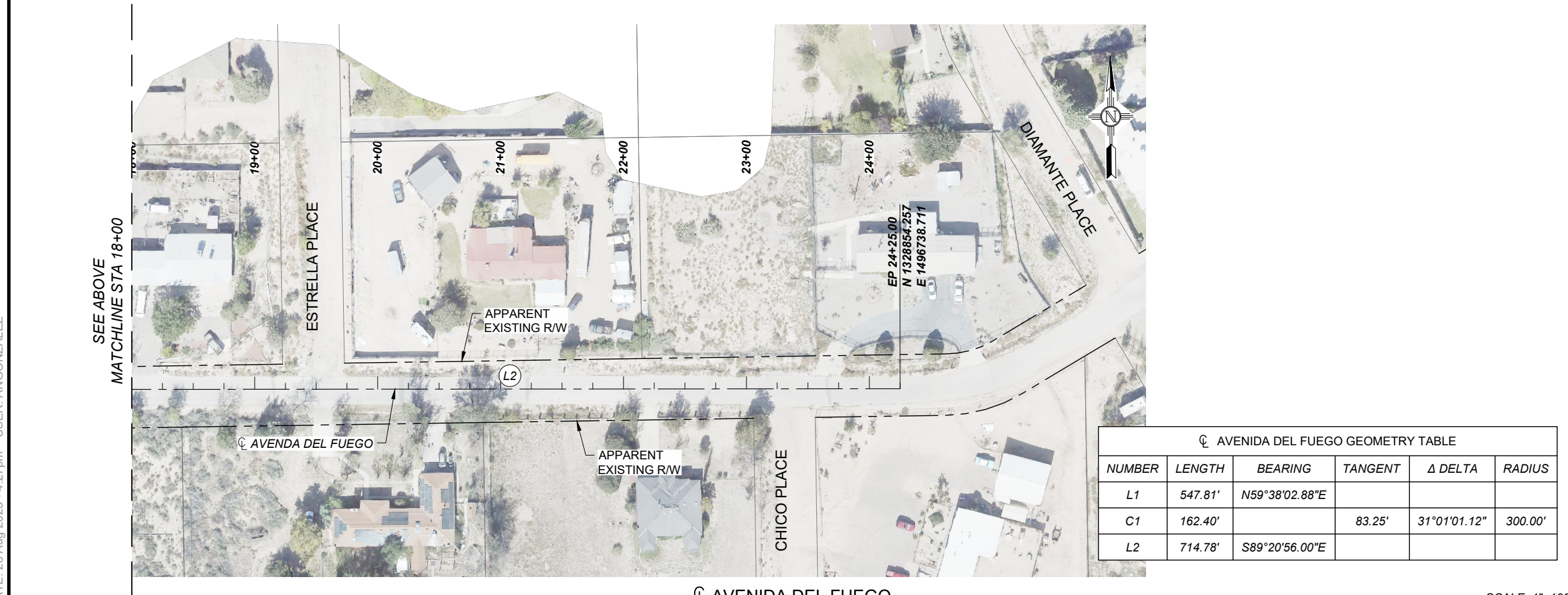

AVENIDA DEL FUEGO

SCALE: 1"=100'

AVENIDA DEL FUEGO GEOMETRY TABLE					
NUMBER	LENGTH	BEARING	TANGENT	Δ DELTA	RADIUS
L1	547.81'	N59°38'02.88"E			
C1	162.40'		83.25'	31°01'01.12"	300.00'
L2	714.78'	S89°20'56.00"E			

GENERAL NOTES
 1. SEE SHEET 3-4 FOR SURVEY CONTROL MAP.

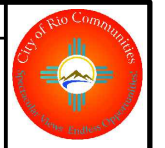

CITY OF RIO COMMUNITIES

NO.	DESCRIPTION	DATE	BY
4			
3			
2			
1			

RIO COMMUNITIES
 DHSEM PROJECTS
 HORIZONTAL LAYOUT PLAN



DATE: 28 Aug 2023 - 4:27 pm USER: ANGONZALEZ



☉ RILEY AVE SCALE: 1"=30'

☉ _ALIGNMENT GEOMETRY TABLE

NUMBER	LENGTH	BEARING	TANGENT	Δ DELTA	RADIUS
L7	250.00'	N74°35'20.57"E			

GENERAL NOTES
 1. SEE SHEET 3-4 FOR SURVEY CONTROL MAP.

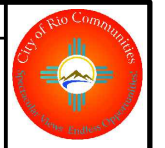

CITY OF RIO COMMUNITIES

NO.	DESCRIPTION	DATE	BY
4			
3			
2			
1			

RIO COMMUNITIES
 DHSEM PROJECTS
 HORIZONTAL LAYOUT PLAN

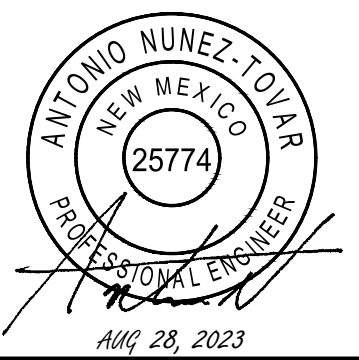

DATE: 28 Aug 2023 - 4:27 pm USER: ANGONZALEZ

GENERAL NOTES

- SEE SHEET 3-4 FOR SURVEY CONTROL MAP.



CITY OF RIO COMMUNITIES

NO.	DESCRIPTION	DATE	BY
4			
3			
2			
1			

RIO COMMUNITIES
DHSEM PROJECTS
HORIZONTAL LAYOUT PLAN

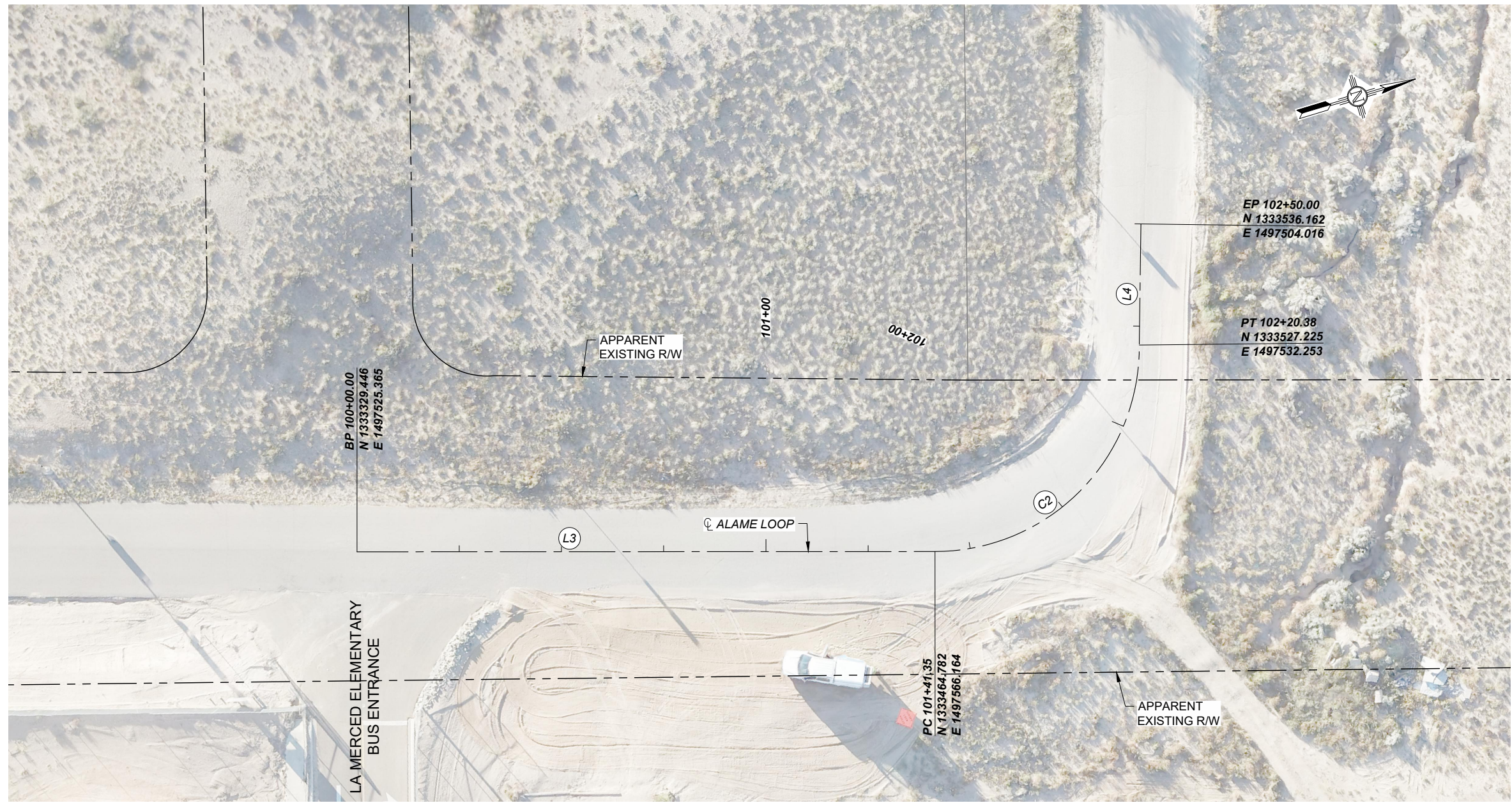

ALAME LOOP

SCALE: 1"=30'

NUMBER	LENGTH	BEARING	TANGENT	Δ DELTA	RADIUS
L3	141.35'	N16°46'34.23"E			
C2	79.03'		50.49'	90°33'44.63"	50.00'
L4	29.62'	N72°26'15.86"W			



DATE: 28 Aug 2023 - 4:27 pm USER: ANGONZALEZ

GENERAL NOTES:

1. ALL SURVEY CONTROL POINTS WERE SET BY THE COLLIERS ENGINEERING & DESIGN SURVEY UNIT IN OCTOBER 2022.
2. THE STATE PLANE COORDINATES SHOWN HEREON ARE REFERRED TO THE NEW MEXICO COORDINATE SYSTEM - CENTRAL ZONE, NORTH AMERICAN DATUM OF 1983 AND WERE DERIVED USING VRS DIFFERENTIAL POSITIONING TECHNIQUES. VRS OBSERVATIONS WERE PERFORMED BY THE COLLIERS ENGINEERING & DESIGN SURVEY UNIT.
3. THE ELEVATIONS WERE DERIVED USING VRS ELLIPSOID HEIGHT DIFFERENCES COMBINED WITH THE NGS GEOID MODELING PROGRAM 'GEOID18'.
4. THE LOCAL PROJECT GROUND COORDINATES SHOWN HEREON WERE DERIVED USING THE FOLLOWING FORMULA:
4.1. THE FINAL ADJUSTED STATE PLANE GRID COORDINATES ARE DERIVED FROM AN OPUS SOLUTION ON CP-5 AND COORDINATES ARE SCALED TO THE SURFACE USING COMBINED GRID TO THE GROUND FACTOR OF 1.000307745 AROUND AN ORIGIN OF 0,0.
5. ALL DISTANCES SHOWN HEREON ARE CALCULATED GROUND DISTANCES USING THE INVERSED GRID DISTANCES AND THE PROJECT AVERAGE COMBINED GRID TO GROUND SCALE FACTOR.
6. THE FIELD DATA WAS COLLECTED USING VRS NETWORK / TRIMBLE GPS RECEIVERS AND ADJUSTED UTILIZING TRIMBLE BUSINESS CENTER SOFTWARE IN OCTOBER 2022.

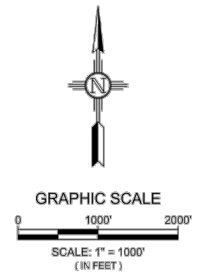
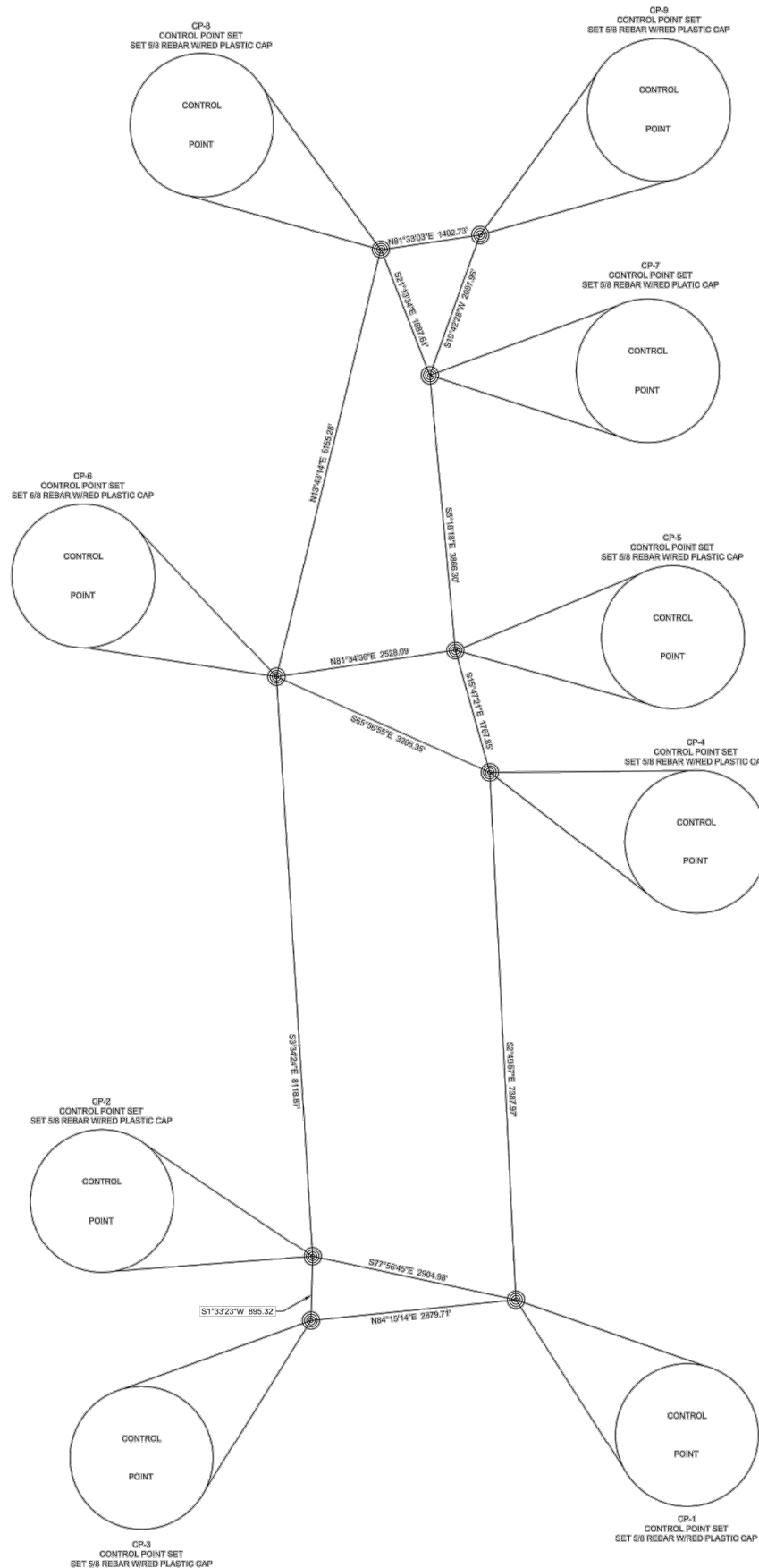

LOCAL PROJECT GROUND COORDINATES					
STATION	NORTHING [US FEET]	EASTING [US FEET]	ELEVATION	DESCRIPTION	LOCATION
CP-1	1319844.254	1498510.800	4910.70	REBAR WITH 1 1/4\" RED PC CONTROL POINT	CP-1 IS LOCATED 95' SOUTH OF LA ISLA AND LEE TREVINO BLVD INTERSECTION, 25' WEST OF LEE TREVINO BLVD CL.
CP-2	1320550.924	1495669.873	4877.01	REBAR WITH 1 1/4\" RED PC CONTROL POINT	CP-2 IS LOCATED 680' WEST OF SAN LUCAS AVE AND TRES CANTOS AVE INTERSECTION AND IS 285' NW OF SAN LUCAS CL. PT. 12' WEST OF A DIRT ROAD CL.
CP-3	1319655.935	1495645.555	4896.14	REBAR WITH 1 1/4\" RED PC CONTROL POINT	CP-3 IS LOCATED 340' FROM END OF PAVEMENT OF SAN LUCAS AVE. SOUTH BOUND. 30' EAST OF A DIRT ROAD CL.
CP-4	1327323.200	1489145.769	4897.75	REBAR WITH 1 1/4\" RED PC CONTROL POINT	CP-4 IS LOCATED 50' NW FROM OF GOODMAN AVE. AND DOERING ST. INTERSECTION.
CP-5	1329024.347	1497664.683	4904.51	REBAR WITH 1 1/4\" RED PC CONTROL POINT	CP-5 IS LOCATED 40' EAST OF AVENIDA DEL FUEGO AND SOMBRERO LP INTERSECTION. 35' EAST OF SOMBRERO LP CL.
CP-6	132854.912	1495163.860	4825.37	REBAR WITH 1 1/4\" RED PC CONTROL POINT	CP-6 IS LOCATED 210' NW OF NM 47 AND NM 304 INTERSECTION. 5' EAST OF CHAIN LINK FENCE.
CP-7	1332874.088	1497307.221	4908.76	REBAR WITH 1 1/4\" RED PC CONTROL POINT	CP-7 IS LOCATED 100' NW OF ALAME LOOP AND LA MERCED ELEMENTARY SCHOOL PARKING ENTRANCE INTERSECTION. 80' WEST OF ALAME LOOP CL.
CP-8	1334633.640	1496623.817	4874.76	REBAR WITH 1 1/4\" RED PC CONTROL POINT	CP-8 IS LOCATED 55' NW OF SHERROD BLVD AND ALAME LOOP INTERSECTION. 15' WEST OF A DIRT ROAD CL.
CP-9	1334839.748	1498911.327	4964.84	REBAR WITH 1 1/4\" RED PC CONTROL POINT	CP-9 IS LOCATED 20' NE OF CL END OF PAVEMENT OF SHERROD BLVD. 380' EAST OF SE BLDG CORNER OF CHURCH OF CHRIST RD GRANDE.

GEODETTIC INFORMATION GEOGRAPHIC/STATE PLANE NAD83(2011) COORDINATES							
STATION	LATITUDE	LONGITUDE	NORTHING [USF]	EASTING [USF]	Zone	Geoid [USF] Separation	ELLIPSOID HEIGHT [USF]
CP-1	34°37'33.80573\"	-106°43'23.69732\"	1319838.173	1498049.783	NM C (3002)	-71.95	4838.75
CP-2	34°37'39.67186\"	-106°43'57.71777\"	1320144.656	1495209.730	NM C (3002)	-72.02	4804.99
CP-3	34°37'30.82023\"	-106°43'57.05744\"	1319249.942	1495185.419	NM C (3002)	-72.01	4824.13
CP-4	34°39'46.75856\"	-106°43'28.48044\"	1326914.649	1497684.804	NM C (3002)	-72.00	4825.75
CP-5	34°39'03.55856\"	-106°43'34.33259\"	1328615.472	1497203.926	NM C (3002)	-72.03	4832.46
CP-6	34°38'59.77849\"	-106°44'04.23723\"	1328245.251	1494703.872	NM C (3002)	-72.08	4753.29
CP-7	34°39'41.61149\"	-106°43'38.82838\"	1332464.629	1496946.574	NM C (3002)	-72.05	4835.70
CP-8	34°39'58.97936\"	-106°43'47.10764\"	1334223.040	1496163.380	NM C (3002)	-72.07	4802.69
CP-9	34°40'01.08257\"	-106°43'30.51259\"	1334429.084	1497550.463	NM C (3002)	-72.04	4832.80

LEGEND

⊙ SET 5/8\" REBAR & 1 1/4\" RED PLASTIC CAP

NO.	DESCRIPTION	DATE	BY
4			
3			
2			
1			

REVISIONS (OR CHANGE NOTICES)



I, CLAY A. WYGANT, NMPLS# 12808, DO HEREBY CERTIFY THAT THIS CONTROL SURVEY MAP AND REPORT WAS PREPARED BY ME OR UNDER MY DIRECT SUPERVISION BASED ON AN ACTUAL SURVEY ON THE GROUND AS DESCRIBED HEREIN; THAT I AM RESPONSIBLE FOR THIS SURVEY; AND THAT THE SURVEY AND REPORT MEETS THE MINIMUM STANDARDS FOR SURVEYING IN NEW MEXICO.

Clay Wygant
 CLAY A. WYGANT N.M.P.S. 12808
 COLLIERS ENGINEERING & DESIGN
 2703 BRADBENT PKWY NE SUITE B
 ALBUQUERQUE, NM 87107
 PH # (505) 433-6363

03/15/2023

DATE



RIO COMMUNITIES

RIO COMMUNITIES
CONTROL MAP

COLLIERS ENGINEERING & DESIGN PROJECT NO.

22002754

VALANCIA COUNTY

SCALE 1"=1000"

SHEET 1 OF 1

CITY OF RIO COMMUNITIES

4
3
2
1
NO.

CN 2021-040-002
 DHSEM PROJECTS
 SURVEY CONTROL MAP

DESCRIPTION
 DATE
 BY



CITY OF RIO COMMUNITIES

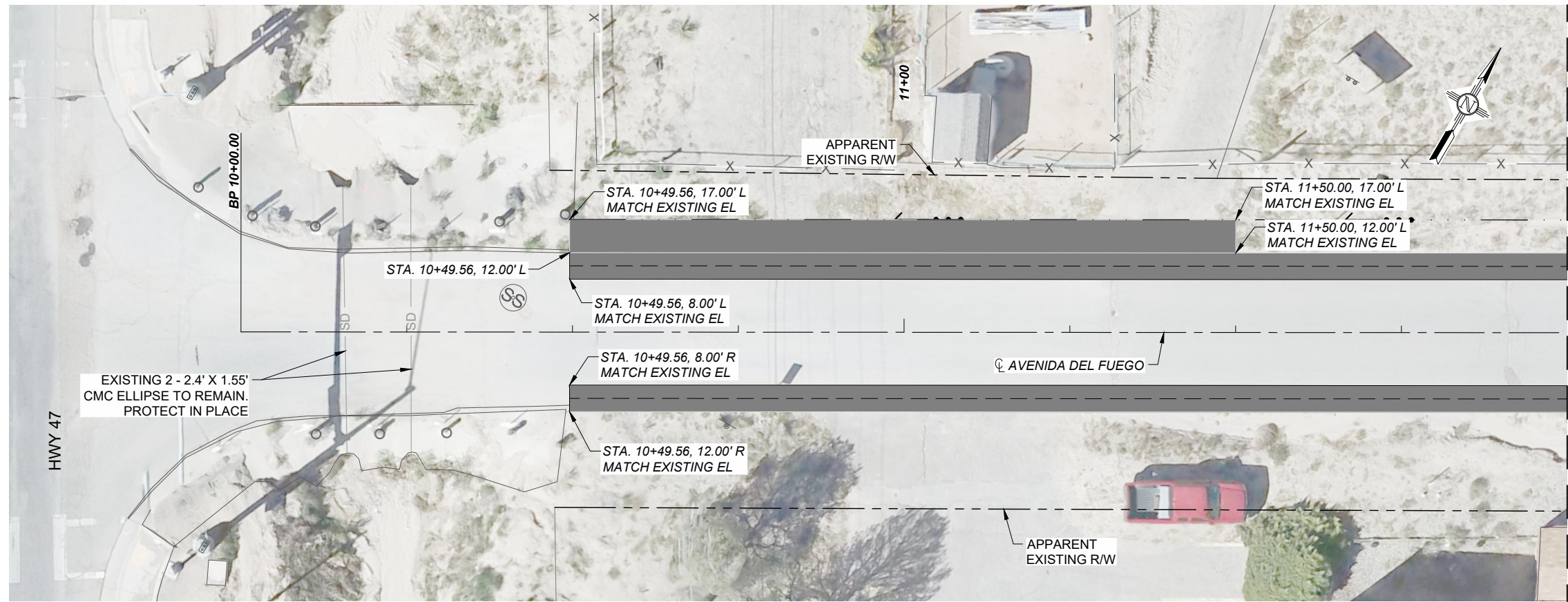

AVENIDA DEL FUEGO

SCALE: 1"=20'

MATCHLINE STA 12+00
SEE BELOW

KEYED NOTES

- CLEAN EXISTING CULVERT.

GENERAL NOTES

- ALL EXISTING DRAINAGE STRUCTURES/CULVERTS SHALL BE CLEANED PER NMDOT SPEC. SECTION 613 AND INCLUDED IN ITEM NUMBER 613000 CLEANING CULVERTS AND DRAINAGE STRUCTURES.
- ALL DRAINAGE STRUCTURES THAT WILL BE REMOVED SHALL BE DISPOSED PER NMDOT SPEC. SECTION 601 AND INCLUDED IN ITEM NUMBER 60100 REMOVAL OF STRUCTURES AND OBSTRUCTIONS.

LEGEND

- NEW ASPHALT PAVEMENT PER SECTION 1 ON SHEET 2-2
- NEAT VERTICAL SAWCUT
- FLOW DIRECTION
- DITCH FLOWLINE
- EXISTING FENCE

NO.	DESCRIPTION	DATE	BY
4			
3			
2			
1			

SEE ABOVE
MATCHLINE STA 12+00

MATCHLINE STA 14+25
SEE NEXT SHEET

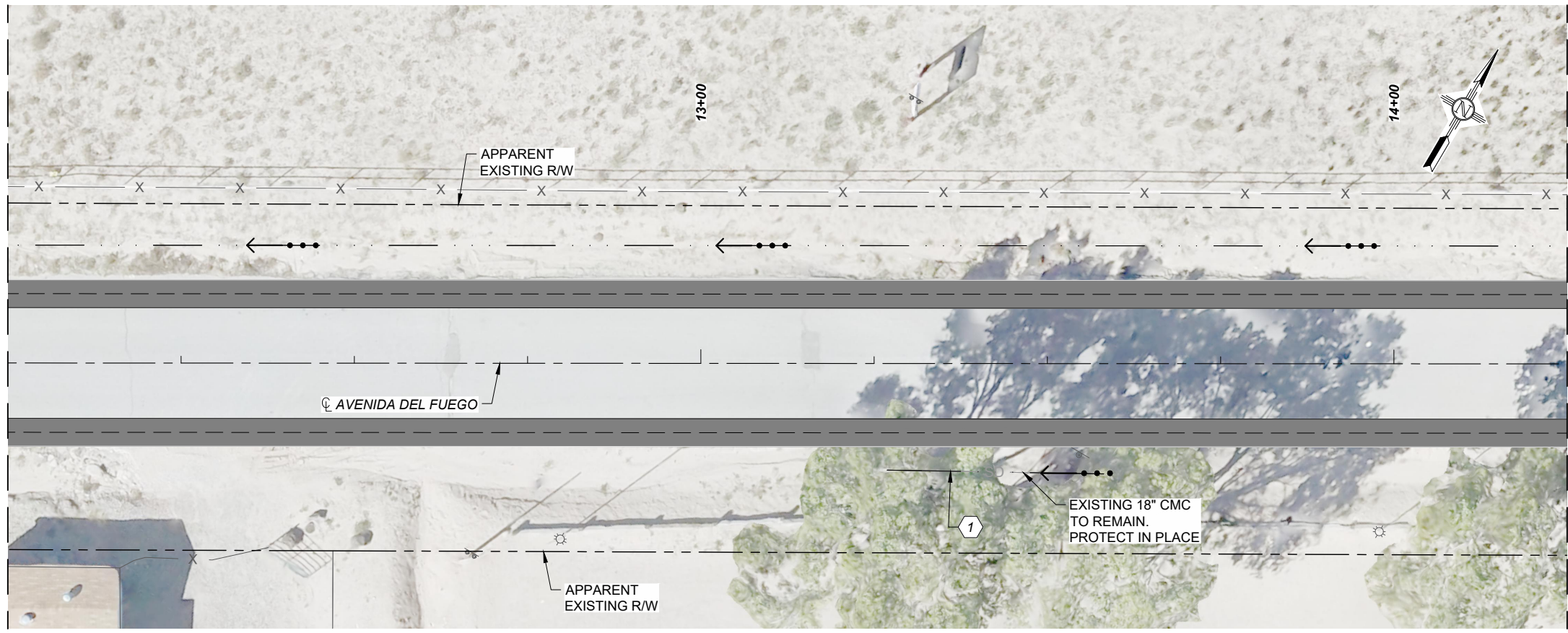

AVENIDA DEL FUEGO

SCALE: 1"=20'



CN 2021-040-002
DHSEM PROJECTS
PERMANENT DRAINAGE PLAN

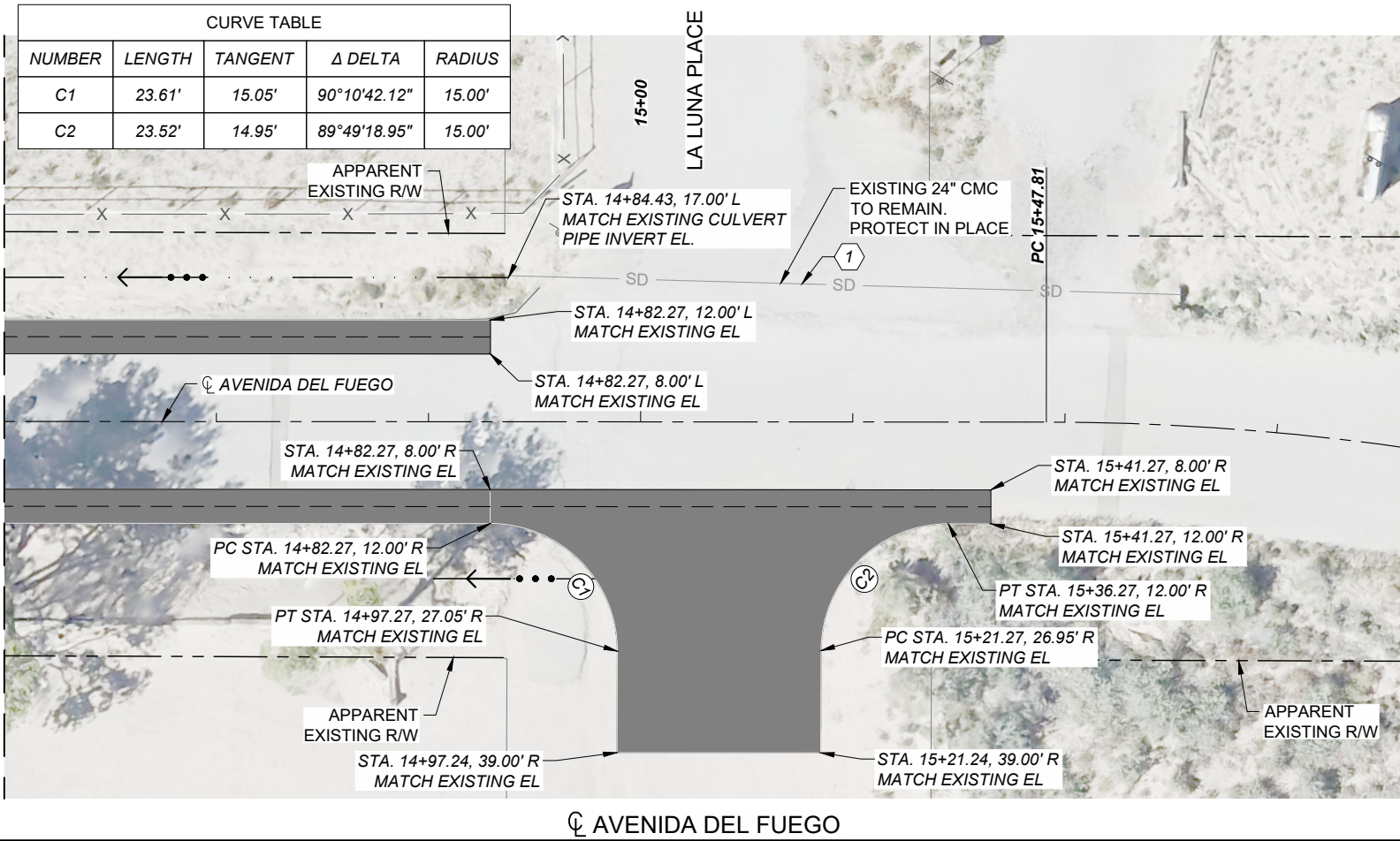

CURVE TABLE				
NUMBER	LENGTH	TANGENT	Δ DELTA	RADIUS
C1	23.61'	15.05'	90°10'42.12"	15.00'
C2	23.52'	14.95'	89°49'18.95"	15.00'

SEE PREVIOUS SHEET
MATCHLINE STA 14+25

SCALE: 1"=20'

KEYED NOTES

- CLEAN EXISTING CULVERT.

GENERAL NOTES

- ALL EXISTING DRAINAGE STRUCTURES/CULVERTS SHALL BE CLEANED PER NMDOT SPEC. SECTION 613 AND INCLUDED IN ITEM NUMBER 613000 CLEANING CULVERTS AND DRAINAGE STRUCTURES.
- ALL DRAINAGE STRUCTURES THAT WILL BE REMOVED SHALL BE DISPOSED PER NMDOT SPEC. SECTION 601 AND INCLUDED IN ITEM NUMBER 60100 REMOVAL OF STRUCTURES AND OBSTRUCTIONS.

LEGEND

- NEW ASPHALT PAVEMENT PER SECTION 1 ON SHEET 2-2
- NEAT VERTICAL SAWCUT
- ←••• FLOW DIRECTION
- DITCH FLOWLINE
- X - EXISTING FENCE

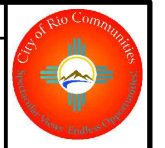

CITY OF RIO COMMUNITIES

NO.	DESCRIPTION	DATE	BY
4			
3			
2			
1			



CN 2021-040-002
DHSEM PROJECTS
PERMANENT DRAINAGE PLAN

DATE: 28 Aug 2023 - 4:28pm USER: ANGONZALEZ

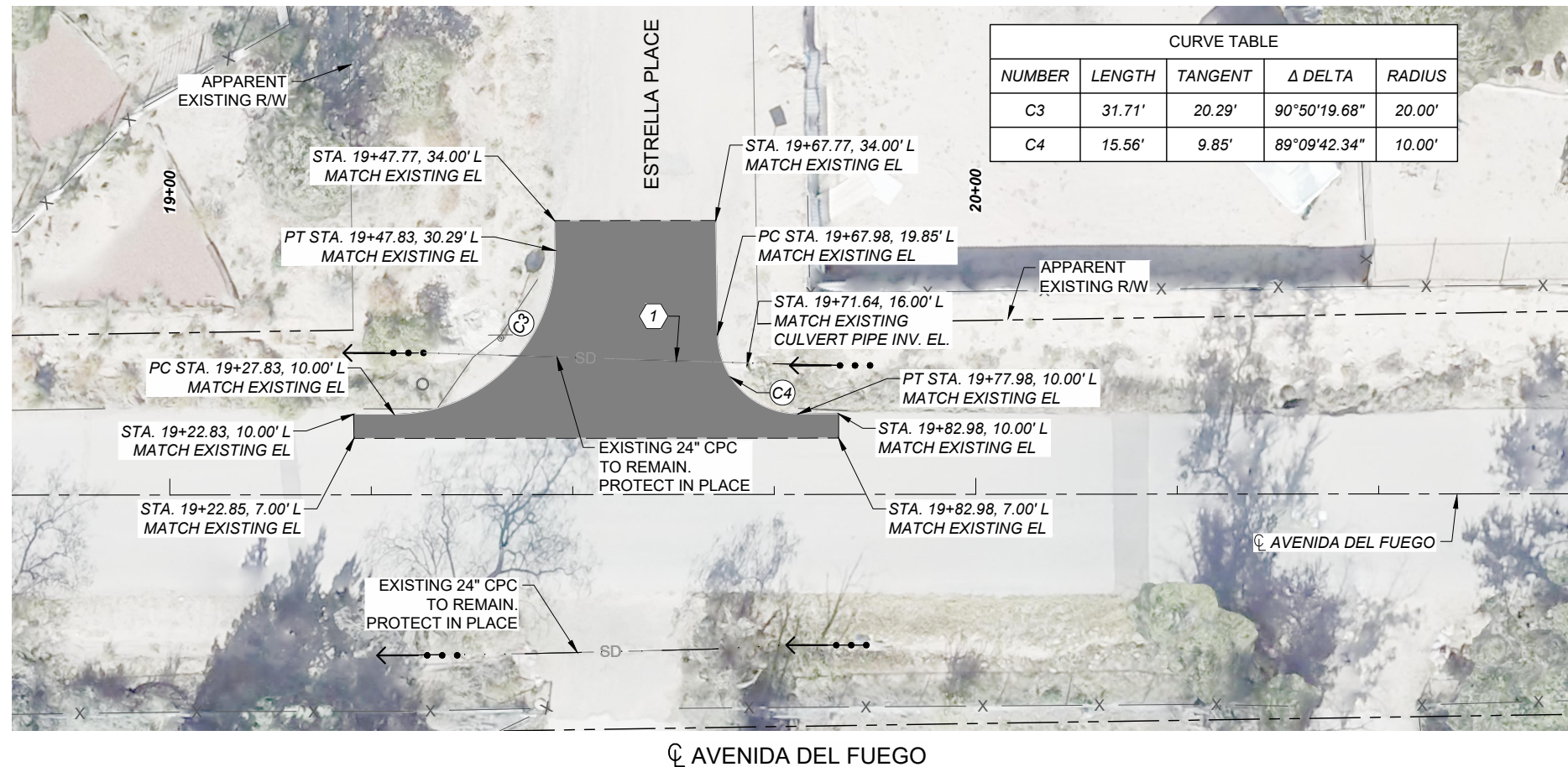

CURVE TABLE				
NUMBER	LENGTH	TANGENT	Δ DELTA	RADIUS
C3	31.71'	20.29'	90°50'19.68"	20.00'
C4	15.56'	9.85'	89°09'42.34"	10.00'



SCALE: 1"=20'

KEYED NOTES

- 1. CLEAN EXISTING CULVERT.

GENERAL NOTES

- 1. ALL EXISTING DRAINAGE STRUCTURES/CULVERTS SHALL BE CLEANED PER NMDOT SPEC. SECTION 613 AND INCLUDED IN ITEM NUMBER 613000 CLEANING CULVERTS AND DRAINAGE STRUCTURES.
- 2. ALL DRAINAGE STRUCTURES THAT WILL BE REMOVED SHALL BE DISPOSED PER NMDOT SPEC. SECTION 601 AND INCLUDED IN ITEM NUMBER 60100 REMOVAL OF STRUCTURES AND OBSTRUCTIONS.

LEGEND

- NEW ASPHALT PAVEMENT PER SECTION 1 ON SHEET 2-2
- NEAT VERTICAL SAWCUT
- FLOW DIRECTION
- DITCH FLOWLINE
- EXISTING FENCE



CITY OF RIO COMMUNITIES

NO.	DESCRIPTION	DATE	BY
4			
3			
2			
1			

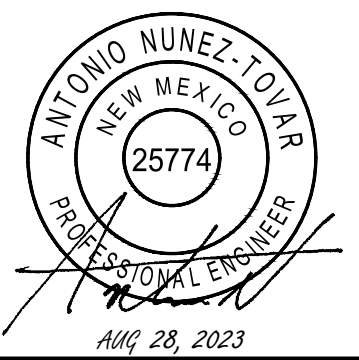

CN 2021-040-002
DHSEM PROJECTS
PERMANENT DRAINAGE PLAN

DATE: 28 Aug 2023 - 4:28pm USER: ANGONZALEZ



CITY OF RIO COMMUNITIES

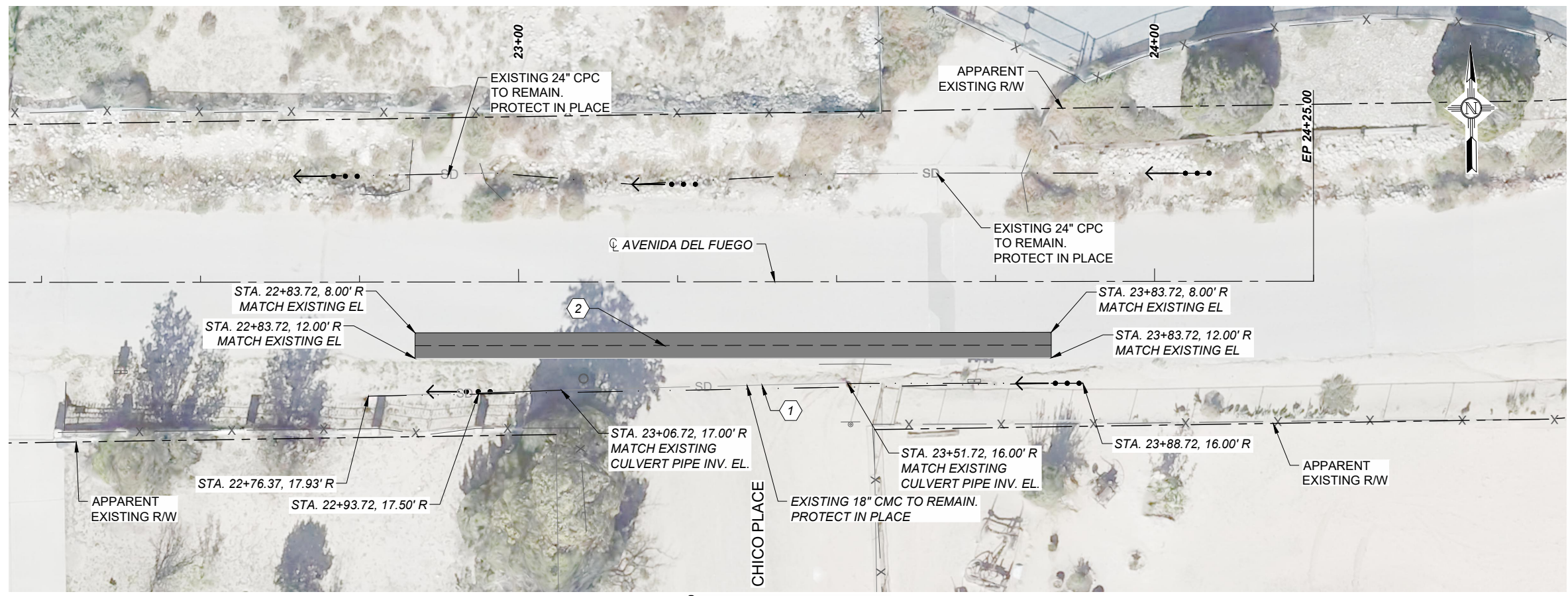

AVENIDA DEL FUEGO

SCALE: 1"=20'

KEYED NOTES

- 1. CLEAN EXISTING CULVERT.

GENERAL NOTES

- 1. ALL EXISTING DRAINAGE STRUCTURES/CULVERTS SHALL BE CLEANED PER NMDOT SPEC. SECTION 613 AND INCLUDED IN ITEM NUMBER 613000 CLEANING CULVERTS AND DRAINAGE STRUCTURES.
- 2. ALL DRAINAGE STRUCTURES THAT WILL BE REMOVED SHALL BE DISPOSED PER NMDOT SPEC. SECTION 601 AND INCLUDED IN ITEM NUMBER 60100 REMOVAL OF STRUCTURES AND OBSTRUCTIONS.

LEGEND

- NEW ASPHALT PAVEMENT PER SECTION 1 ON SHEET 2-2
- NEAT VERTICAL SAWCUT
- FLOW DIRECTION
- DITCH FLOWLINE
- EXISTING FENCE

NO.	DESCRIPTION	DATE	BY
4			
3			
2			
1			

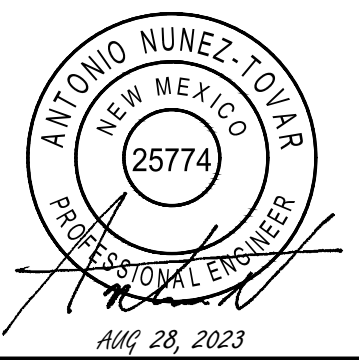

CN 2021-040-002
DHSEM PROJECTS
PERMANENT DRAINAGE PLAN

DATE: 28 Aug 2023 - 4:28pm USER: ANGONZALEZ



CITY OF RIO COMMUNITIES

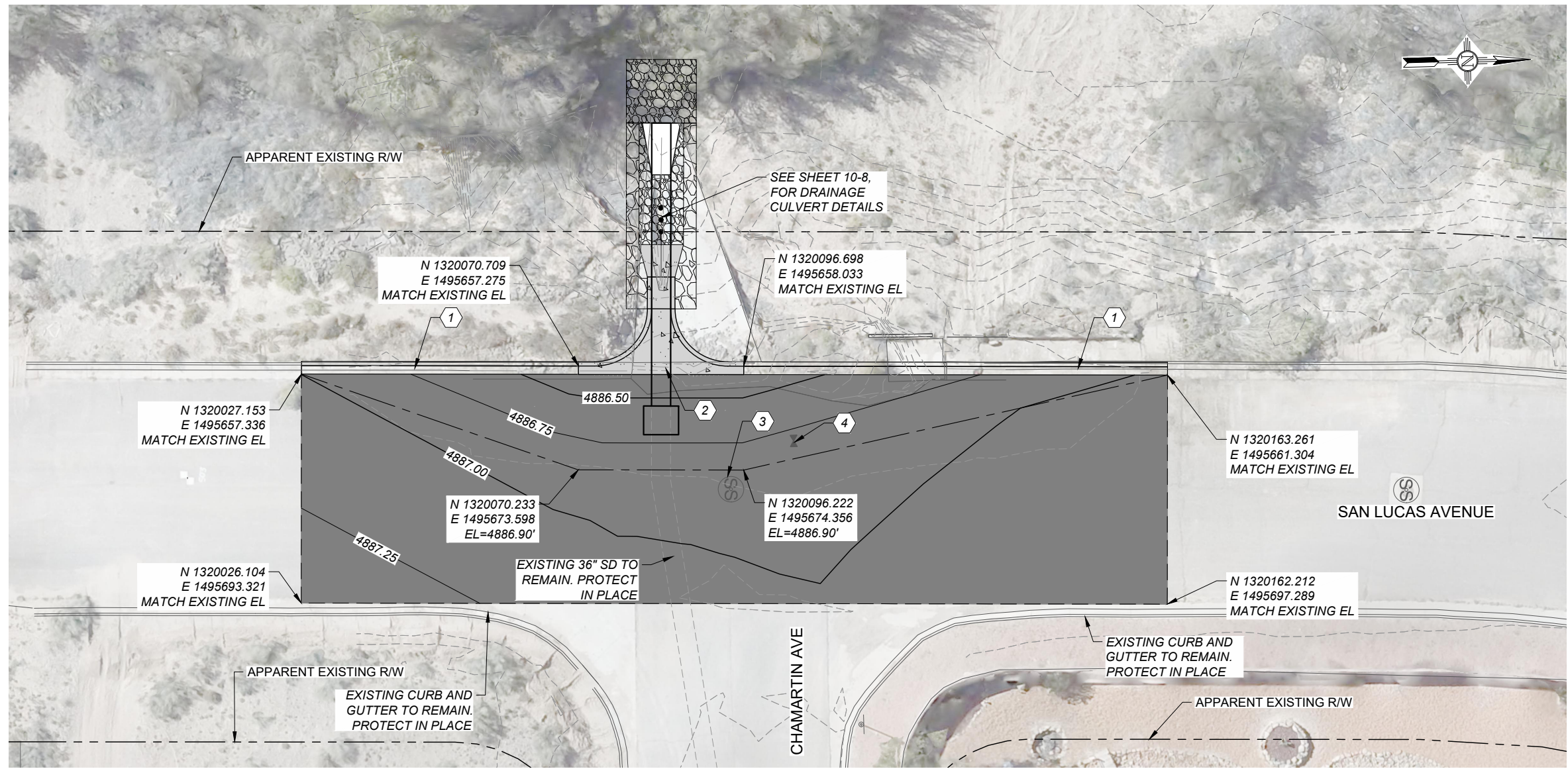

KEYED NOTES

- BUILD CONCRETE VERTICAL CURB & GUTTER TYPE B 6"X24" PER NMDOT STD. DWG 609-01-1/1.
- BUILD CONCRETE RUNDOWN FLUME, SEE SHEET 10-8.
- ADJUST EX MH TO FINAL GRADE. PER NMDOT SPEC. 662
- ADJUST EX VALVE TO FINAL GRADE. PER NMDOT SPEC. 662

GENERAL NOTES

- ALL EXISTING DRAINAGE STRUCTURES/CULVERTS SHALL BE CLEANED PER NMDOT SPEC. SECTION 613 AND INCLUDED IN ITEM NUMBER 613000 CLEANING CULVERTS AND DRAINAGE STRUCTURES.
- ALL DRAINAGE STRUCTURES THAT WILL BE REMOVED SHALL BE DISPOSED PER NMDOT SPEC. SECTION 601 AND INCLUDED IN ITEM NUMBER 60100 REMOVAL OF STRUCTURES AND OBSTRUCTIONS.

LEGEND

- PROPOSED PAVEMENT SECTION 1. SEE SECTION 2.
- RIPRAP NMDOT CLASS G
- RIPRAP NMDOT CLASS A
- NEAT VERTICAL SAWCUT
- CONTRACTOR USE ONLY, GRADING LIMITS.



NO.	DESCRIPTION	DATE	BY
4			
3			
2			
1			

RIO COMMUNITIES
DHSEM PROJECTS
PERMANENT DRAINAGE PLAN

DATE: 28 Aug 2023 - 4:28pm USER: ANGONZALEZ



CITY OF RIO COMMUNITIES

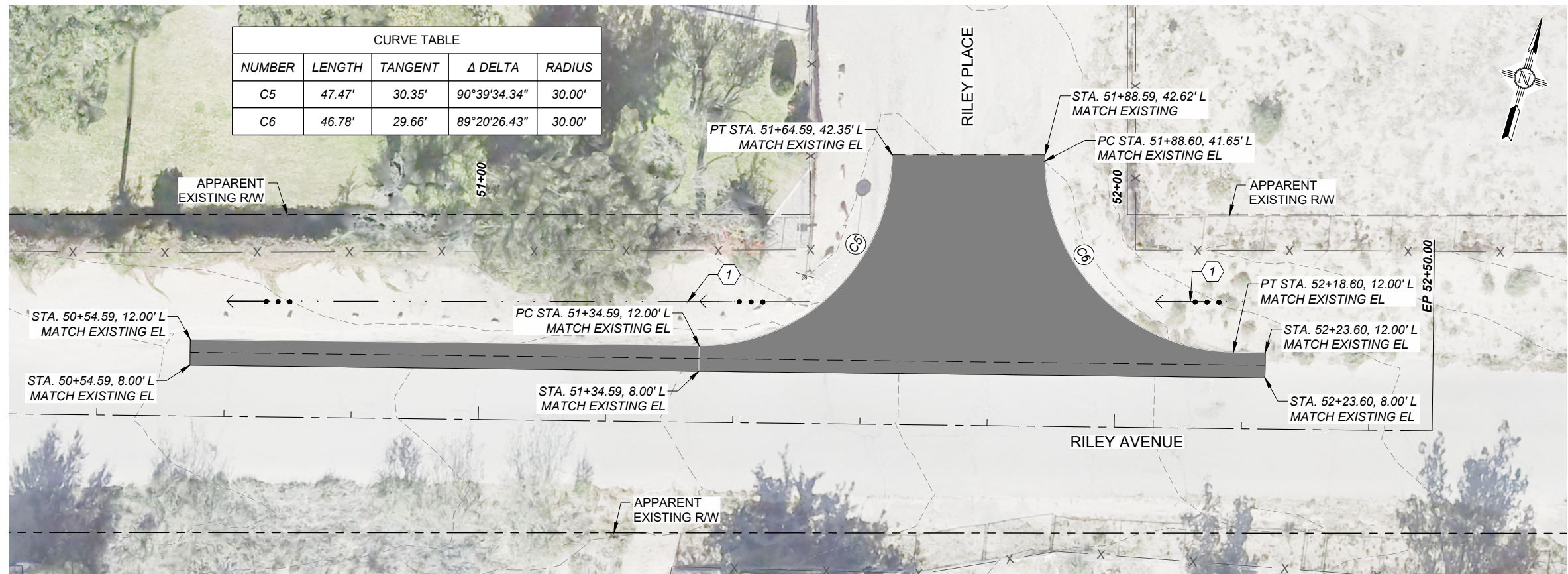

CURVE TABLE				
NUMBER	LENGTH	TANGENT	Δ DELTA	RADIUS
C5	47.47'	30.35'	90°39'34.34"	30.00'
C6	46.78'	29.66'	89°20'26.43"	30.00'

SCALE: 1"=20'

KEYED NOTES

- RESTORE EXISTING ROADSIDE DITCH PER TYPICAL SECTIONS ON SHEET 2-2.

GENERAL NOTES

- ALL EXISTING DRAINAGE STRUCTURES/CULVERTS SHALL BE CLEANED PER NMDOT SPEC. SECTION 613 AND INCLUDED IN ITEM NUMBER 613000 CLEANING CULVERTS AND DRAINAGE STRUCTURES.
- ALL DRAINAGE STRUCTURES THAT WILL BE REMOVED SHALL BE DISPOSED PER NMDOT SPEC. SECTION 601 AND INCLUDED IN ITEM NUMBER 60100 REMOVAL OF STRUCTURES AND OBSTRUCTIONS.

LEGEND

- NEW ASPHALT PAVEMENT PER SECTION 1 ON SHEET 2-2
- - - NEAT VERTICAL SAWCUT
- ←••• FLOW DIRECTION
- DITCH FLOWLINE
- X - EXISTING FENCE

NO.	DESCRIPTION	DATE	BY
4			
3			
2			
1			



RIO COMMUNITIES
DHSEM PROJECTS
PERMANENT DRAINAGE PLAN

DATE: 28 Aug 2023 - 4:28pm USER: ANGONZALEZ

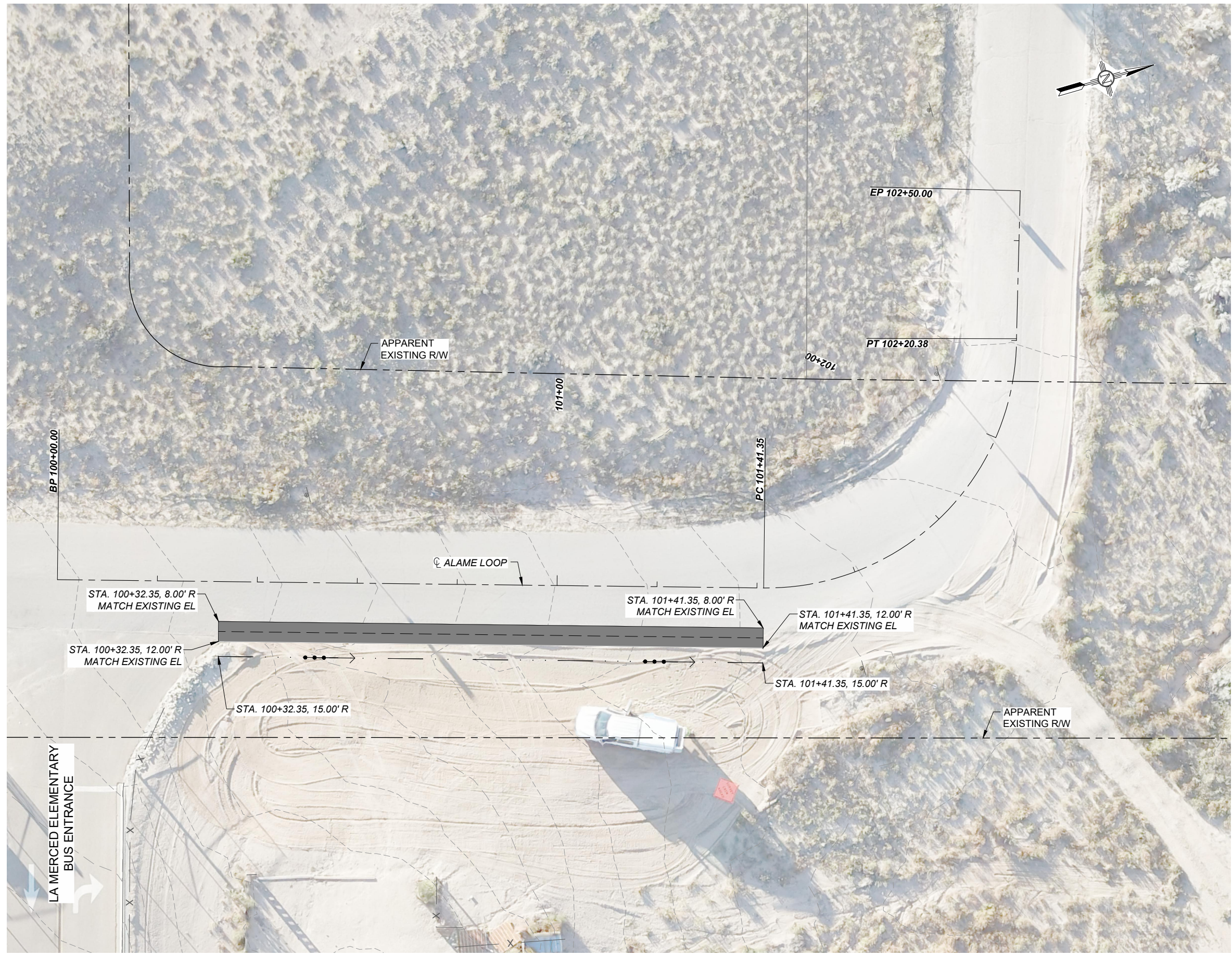

KEYED NOTES

- CLEAN EXISTING CULVERT.

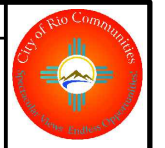

CITY OF RIO COMMUNITIES

GENERAL NOTES

- ALL EXISTING DRAINAGE STRUCTURES/CULVERTS SHALL BE CLEANED PER NMDOT SPEC. SECTION 613 AND INCLUDED IN ITEM NUMBER 613000 CLEANING CULVERTS AND DRAINAGE STRUCTURES.
- ALL DRAINAGE STRUCTURES THAT WILL BE REMOVED SHALL BE DISPOSED PER NMDOT SPEC. SECTION 601 AND INCLUDED IN ITEM NUMBER 60100 REMOVAL OF STRUCTURES AND OBSTRUCTIONS.

LEGEND

- NEW ASPHALT PAVEMENT PER SECTION 1 ON SHEET 2-2
- NEAT VERTICAL SAWCUT
- FLOW DIRECTION
- DITCH FLOWLINE
- EXISTING FENCE

NO.	DESCRIPTION	DATE	BY
4			
3			
2			
1			



CN 2021-040-002
DHSEM PROJECTS
PERMANENT DRAINAGE PLAN

DATE: 28 Aug 2023 - 4:28pm USER: ANGONZALEZ

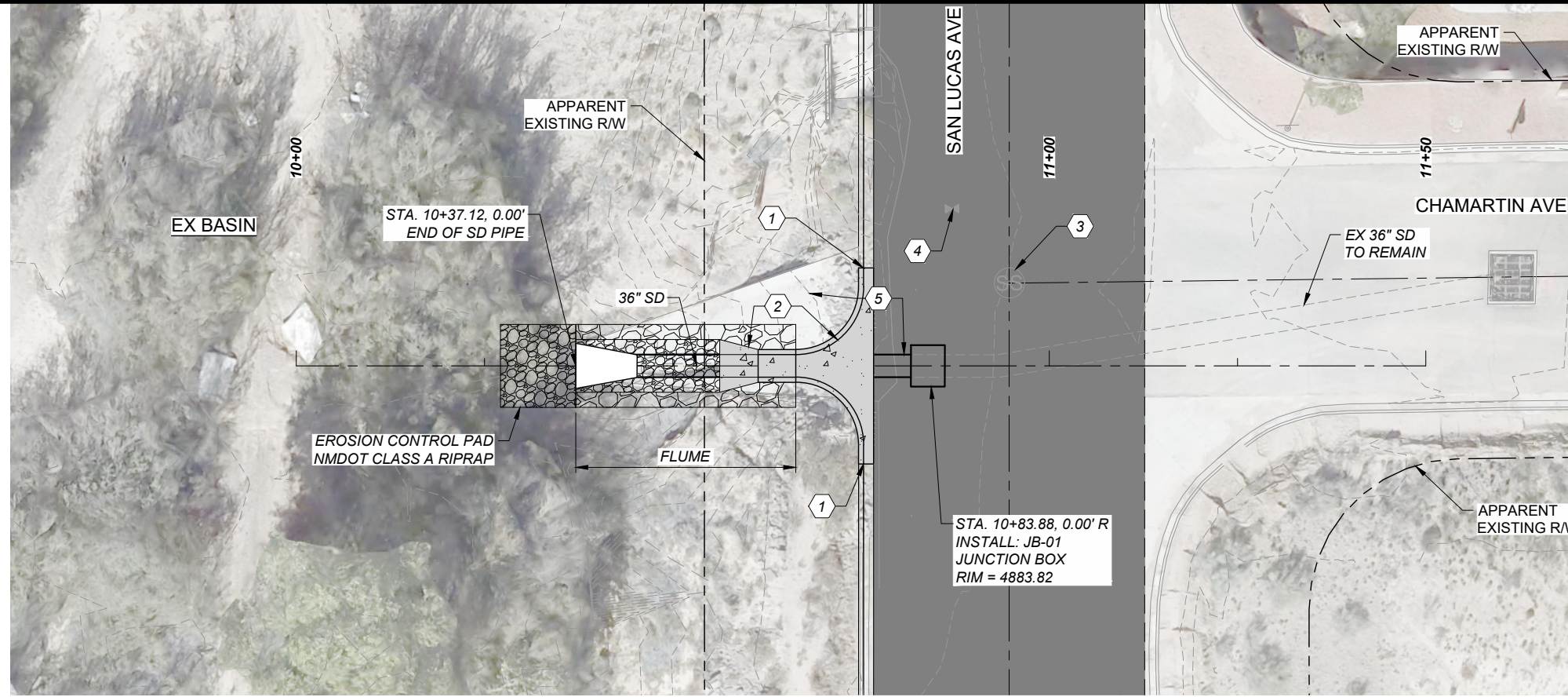

STORM DRAIN SPILLWAY RUN

SCALE: 1"=20'

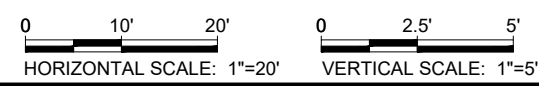
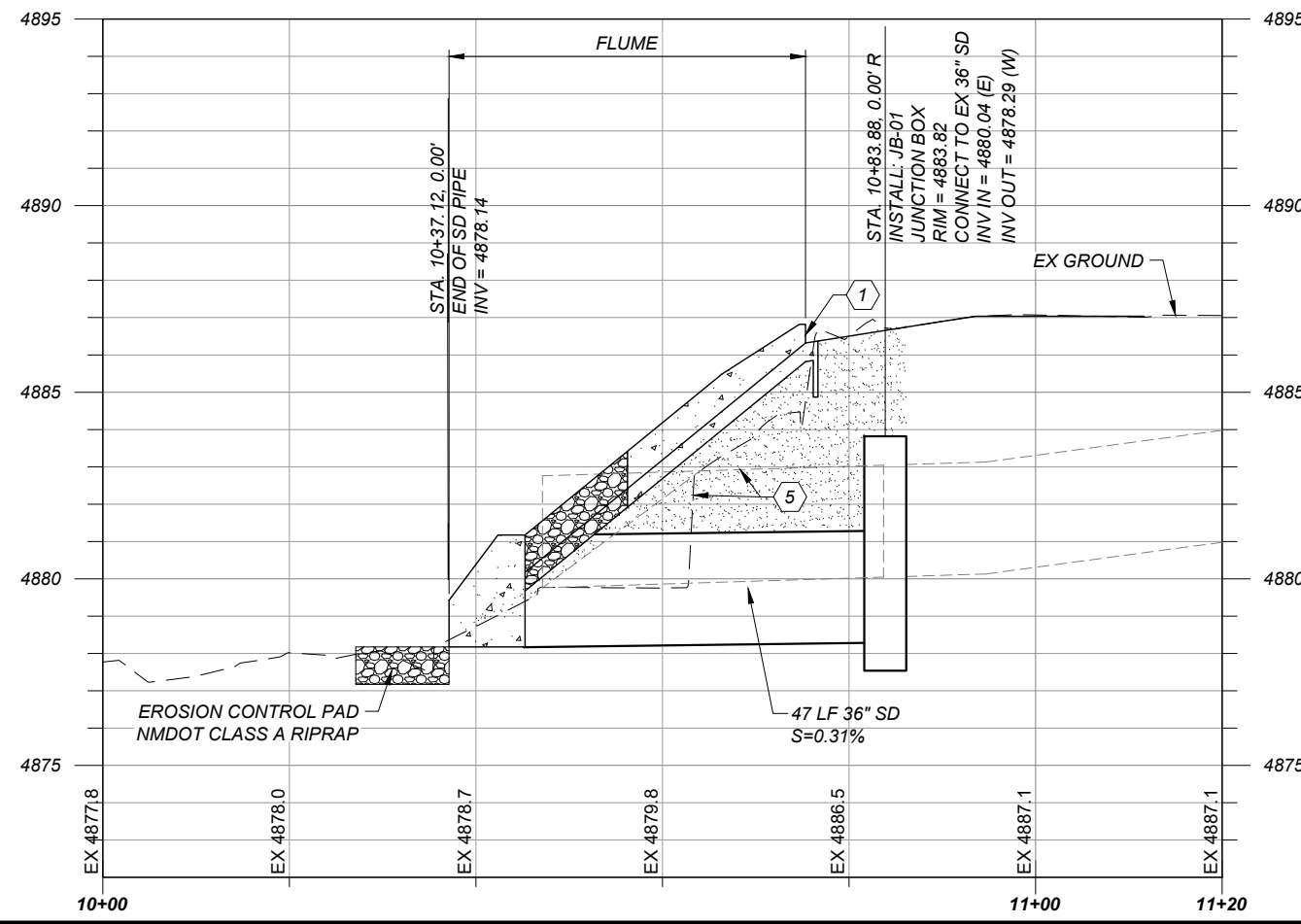

- KEYED NOTES**
- CONNECT TO CONCRETE VERTICAL CURB & GUTTER TYPE B 6"X24" PER NMDOT STD. DWG 609-01-1/1.
 - RUNDOWN FLUME TYPE II PER NMDOT ST DWG 515-03, WITH RIPRAP OPTION SECTION A-A PER DWG 515-02-2/2.
 - ADJUST EX MH TO FINAL GRADE. PER NMDOT SPEC. 662
 - ADJUST EX VALVE TO FINAL GRADE. PER NMDOT SPEC. 662
 - REMOVE EX 36" SD AND CONC. RUNDOWN STRUCTURE.

- GENERAL NOTES**
- ALL EXISTING DRAINAGE STRUCTURES/CULVERTS SHALL BE CLEANED PER NMDOT SPEC. SECTION 613 AND INCLUDED IN ITEM NUMBER 613000 CLEANING CULVERTS AND DRAINAGE STRUCTURES.
 - ALL DRAINAGE STRUCTURES THAT WILL BE REMOVED SHALL BE DISPOSED PER NMDOT SPEC. SECTION 601 AND INCLUDED IN ITEM NUMBER 60100 REMOVAL OF STRUCTURES AND OBSTRUCTIONS.

LEGEND

	RIPRAP NMDOT CLASS G
	RIPRAP NMDOT CLASS A
	PAVEMENT
	COMPACTED FILL

CITY OF RIO COMMUNITIES

NO.	DESCRIPTION	DATE	BY
4			
3			
2			
1			



AUG 28, 2023

CN 2021-040-002
DHSEM PROJECTS
STORM DRAIN SPILLWAY PLAN AND PROFILE

DATE: 28 Aug 2023 - 4:34pm USER: ANGONZALEZ

PURCHASE AGREEMENT CONTRACT

CITY OF RIO COMMUNITIES

Invitation to Bid #2023-0102 Drainage Improvements

THIS AGREEMENT is made and entered into by and between the Governing Body of the City of Rio Communities, State of New Mexico, hereinafter referred to as the "City" and **Desert Fox, LLC**, hereinafter referred to as the "Contractor", and is effective as of the date set forth below upon which it is executed by the Purchasing Agent and the Governing Body.

IT IS AGREED BETWEEN THE PARTIES:

1. Scope of Work.

The Contractor shall deliver products or perform the work outlined on the Scope of Work attached hereto as **Attachment 1** and incorporated herein by reference. Product(s) shall be delivered, or work performed only upon receipt of a valid Purchase Order issued by the City that specifically identifies the products or services to be provided by the Contractor.

2. Compensation.

A. The City shall pay to the Contractor in full payment for product(s) accepted or services satisfactorily performed based on the price(s) found in the Bid Form at **Attachment 1**.

B. Payment is subject to availability of funds pursuant to the Appropriations Paragraph set forth below. All invoices **MUST BE** received by the City no later than fifteen (15) days after the termination of the Fiscal Year in which the services were delivered. Invoices received after such date **WILL NOT BE PAID**.

C. The Contractor shall submit an accurate invoice for each purchase. Any reimbursement of taxes due to the Contractor shall be shown as a separate item. Invoices shall refer to the Purchase Order Number and shall be itemized unless otherwise specified by the City. Invoices are to be mailed to: City of Rio Communities Accounts Payable, 360 Rio Communities Blvd. Rio Communities, NM 87002

D. The payment of taxes due for any money received under this Agreement shall be the Contractor's sole responsibility and shall be reported under the Contractor's Federal and State tax identification number(s).

3. Term.

This Agreement shall terminate upon acceptance by the City and payment for the specified product(s) or services.

4. Termination.

A. Termination. This Agreement may be terminated by either of the parties hereto upon written notice delivered to the other party at least thirty (30) days prior to the intended date of termination. Except as otherwise allowed or provided under this Agreement, the City's sole liability upon such termination shall be to pay for product(s) delivered and accepted or work performed prior to the Contractor's receipt of the notice of termination, if the City is the terminating party, or the Contractor's sending of the notice of termination, if the Contractor is the terminating party; provided, however, that a notice of termination shall not nullify or otherwise affect either party's liability for pre-termination defaults under or breaches of this Agreement. The Contractor shall submit an invoice for product(s) delivered or such work performed within thirty (30) days of receiving or sending the notice of termination. Notwithstanding the foregoing, this Agreement may be terminated immediately upon written notice to the Contractor if the Contractor becomes unable to perform the services contracted for, as determined by the City or if, during the term of this Agreement, the Contractor or any of its officers, employees or agents is indicted for fraud, embezzlement or other crime due to misuse of government funds or due to the Appropriations paragraph herein. THIS PROVISION IS NOT EXCLUSIVE AND DOES NOT WAIVE THE CITY'S OTHER LEGAL RIGHTS AND REMEDIES CAUSED BY THE CONTRACTOR'S DEFAULT/BREACH OF THIS AGREEMENT.

B Termination Management. Immediately upon receipt by either the City or the Contractor of notice of termination of this Agreement, the Contractor shall: 1) not incur any further obligations for salaries, services or any other expenditure of funds under this Agreement without written approval of the City; 2) comply with all directives issued by the City in the notice of termination as to the performance of work under this Agreement; and 3) take such action as the City shall direct for the protection, preservation, retention or transfer of all property titled to the City and records generated under this Agreement. Any non-expendable personal property or equipment provided to or purchased by the Contractor with Contract funds shall become property of the City upon termination and shall be submitted to the City as soon as practicable.

5. Appropriations.

The terms of this Agreement are contingent upon sufficient appropriations and authorization being made by the Governing Body for the performance of this Agreement. If sufficient appropriations and authorization are not made by the Governing Body, this Agreement shall terminate immediately upon written notice being given by the City to the Contractor. The City's decision as to whether sufficient appropriations are available shall be accepted by the Contractor and shall be final. If the City proposes an amendment to the Agreement to unilaterally reduce funding, the Contractor shall have the option to terminate the Agreement or to agree to the reduced funding, within thirty (30) days of receipt of the proposed amendment.

6. Insurance.

The Contractor agrees to obtain and maintain, at the Contractor's expense, such insurance as will protect the Contractor from claims under the Workman's Compensation Act and such comprehensive general liability and automobile insurance as will protect the City and the Contractor from all claims for bodily injury, death, or property damage which may arise from the performance by the Contractor, or by the Contractor employees, for the Contractor's functions and services required under this Agreement. Such insurance shall be in an amount not less than **\$1,000,000.00** for injury to any one person and **\$1,000,000.00** on account of any one accident and in the amount of not less than **\$1,000,000.00** for property damage. The comprehensive liability insurance shall name the City an additional insured with specific endorsements so naming the City for any claims against the City arising from the work performed by the Contractor under this Agreement. The Contractor further agrees to procure and maintain professional liability (errors and omissions, or "E&O") insurance in an amount not less than \$2,000,000.00 per claim and in the aggregate. Prior to commencement of any work, the Contractor shall furnish to the City a certificate that complies with this paragraph. The certificate shall provide that the policy shall not be canceled until at least thirty (30) calendar days prior written notice shall have been given to the City. Contractor shall provide annual updates of the certificate to demonstrate the policy remains in effect for the duration of this Agreement. The failure to have valid policies of insurance in full force and effect at any time during the term of this agreements shall constitute a material breach of this agreement.

Employer's liability coverage will be required of the Contractor and any subcontractor for any class of employee engaged in work under this agreement that is not protected under the Workmen's Compensation Statute. All insurance will be by insurers acceptable to the City and authorized to do business in the state of New Mexico, and who are rated A,A- (A.M. Best Ratings) or AA+/- (S&P). Except as provided below, coverage shall be on an occurrence basis. All insurance policies shall contain a waiver of subrogation against the City. All insurance policies shall be primary. Coverage shall be on ISO coverage forms. Deductibles in excess of \$10,000 per claim may only be approved by the City. Coverage shall be as broad as that provided in ISO CG 20 01 04 13. Self-insured retentions must be declared and approved by the City. Automobile coverage shall be ISO Form CA 001 covering Code 1 (any auto) with the limits of **\$2,000,000** per accident for bodily injury a property damage. If an E&O policy is on a claim made basis, then the date of the policy must be shown and must be before the date of the Contract or the beginning of the scope of work under the Contract, be maintained and evidence for such coverage to be provided for at least five (5) years after completion of the work under the Contract. If such coverage is cancelled or not renewed, and not replaced with another claims made policy form with a retroactive date prior to the effective date of the Contract, then Contractor must purchase "extended reporting" coverage for a minimum of five (5) years after completion of work under the Contract.

7. **Status of Contractor.**

The Contractor and its agents and employees are independent contractors providing product(s) or performing services for the City and are not employees of the City of Rio Communities. The Contractor and its agents and employees shall not accrue leave, retirement, insurance, bonding, use of City vehicles, or any other benefits afforded to employees of the City of Rio Communities as a result of this Agreement. The Contractor acknowledges that all sums received hereunder are reportable by the Contractor for tax purposes, including without limitation, self-employment, and business income tax. The Contractor agrees not to purport to bind the City of Rio Communities unless the Contractor has express written authority to do so, and then only within the strict limits of that authority.

8. **Assignment.**

The Contractor shall not assign or transfer any interest in this Agreement or assign any claims for money due or to become due under this Agreement without the prior written approval of the City. No such assignment or transfer shall relieve the Contractor from the obligations and liabilities under this Agreement.

9. **Subcontracting.**

Not applicable.

10. **Release.**

Final payment of the amounts due under this Agreement shall operate as a release of the procuring agency of the City, its officers and employees, and the City of Rio Communities from all liabilities, claims and obligations whatsoever arising from or under this Agreement.

11. **Confidentiality.**

Any confidential information provided to or developed by the Contractor in the performance of this Agreement shall be kept confidential and shall not be made available to any individual or organization by the Contractor without the prior written approval of the City.

12. **Product of Service -- Copyright.**

All materials developed or acquired by the Contractor under this Agreement shall become the property of the City of Rio Communities and shall be delivered to the City no later than the termination date of this Agreement. Nothing developed or produced, in whole or in part, by the Contractor under this Agreement shall be the subject of an application for copyright or other claim of ownership by or on behalf of the Contractor.

13. **Conflict of Interest; Governmental Conduct Act.**

A. The Contractor represents and warrants that it presently has no interest and, during the term of this Agreement, shall not acquire any interest, direct or indirect, which would conflict in any manner or degree with the performance or services required under the Agreement.

B. The Contractor further represents and warrants that it has complied with, and, during the term of this Agreement, will continue to comply with, and that this Agreement complies with all applicable provisions of the Governmental Conduct Act, Chapter 10, Article 16 NMSA 1978. Without in anyway limiting the generality of the foregoing, the Contractor specifically represents and warrants that:

1) in accordance with Section 10-16-4.3 NMSA 1978, the Contractor does not employ, has not employed, and will not employ during the term of this Agreement any City employee while such employee was or is employed by the City and participating directly or indirectly in the City's contracting process;

2) this Agreement complies with Section 10-16-7(B) NMSA 1978 because (i) the Contractor is not a public officer or employee of the City; (ii) the Contractor is not a member of the family of a public officer or employee of the City; (iii) the Contractor is not a business in which a public officer or employee or the family of a public officer or employee has a substantial interest; or (iv) if the Contractor is a public officer or employee of the City, a member of the family of a public officer or employee of the City, or a business in which a public officer or employee of the City or the family of a public officer or employee of the City has a substantial interest, public notice was given as required by Section 10-16-7(B) NMSA 1978 and this Agreement was awarded pursuant to a competitive process;

3) in accordance with Section 10-16-8(C) NMSA 1978, (i) the Contractor is not, and has not been represented by, a person who has been a public officer or employee of the City within the preceding year and whose official act directly resulted in this Agreement and (ii) the Contractor is not, and has not been assisted in any way regarding this transaction by, a former public officer or employee of the City whose official act, while in City employment, directly resulted in the City's making this Agreement;

4) in accordance with Section 10-16-13 NMSA 1978, the Contractor has not directly participated in the preparation of specifications, qualifications or evaluation criteria for this Agreement or any procurement related to this Agreement; and

5) in accordance with Section 10-16-3 and Section 10-16-13.3 NMSA 1978, the Contractor has not contributed, and during the term of this Agreement shall not contribute, anything of value to a public officer or employee of the City.

C. Contractor's representations and warranties in Paragraphs A and B of this Article 12 are material representations of fact upon which the City relied when this Agreement was entered into by the parties. Contractor shall provide immediate written notice to the City if, at any time during the term of this Agreement, Contractor learns that Contractor's representations and warranties in Paragraphs A and B of this Article 12 were erroneous on the effective date of this Agreement or have become erroneous by reason of new or changed circumstances. If it is later determined that Contractor's representations and warranties in Paragraphs A and B of this Article 12 were erroneous on the effective date of this Agreement or have become erroneous by reason of new or changed circumstances, in addition to other remedies available to the City and notwithstanding anything in the Agreement to the contrary, the City may immediately terminate the Agreement.

D. All terms defined in the Governmental Conduct Act have the same meaning in this Article 12(B).

14. Amendment.

This Agreement shall not be altered, changed, or amended except by instrument in writing executed by the parties hereto and all other required signatories.

15. Merger.

This Agreement incorporates all the Agreements, covenants and understandings between the parties hereto concerning the subject matter hereof, and all such covenants, Agreements and understandings have been merged into this written Agreement. No prior Agreement or understanding, oral or otherwise, of the parties or their agents shall be valid or enforceable unless embodied in this Agreement.

16. Penalties for violation of law.

The Procurement Code, Sections 13-1-28 through 13-1-199, NMSA 1978, imposes civil and criminal penalties for its violation. In addition, the New Mexico criminal statutes impose felony penalties for illegal bribes, gratuities, and kickbacks.

17. Equal Opportunity Compliance.

The Contractor agrees to abide by all federal, state and City laws and rules and regulations, pertaining to equal employment opportunity. In accordance with all such laws, the Contractor assures that no person in the United States shall, on the grounds of race, religion, color, national origin, ancestry, sex, age, physical or mental handicap, or serious medical condition, spousal affiliation, sexual orientation, or gender identity, be excluded from employment with or participation in, be denied the benefits of, or be otherwise subjected to discrimination under any program or activity performed under this Agreement. If Contractor is found not to be in compliance with these requirements during the life of this Agreement, Contractor agrees to take appropriate steps to correct these deficiencies.

18. Applicable Law.

In any action, suit or legal dispute arising from this Agreement, the Contractor agrees that the laws of the State of New Mexico shall govern, and that venue will lie in the Seventh Judicial District Court in City of Rio Communities. By execution of this Agreement, Contractor acknowledges and agrees to the jurisdiction of the courts of the State of New Mexico over any and all lawsuits arising under or out of any term of this Agreement.

19. Workers Compensation.

The Contractor agrees to comply with state laws and rules applicable to workers compensation benefits for its employees. If the Contractor fails to comply with the Workers Compensation Act and applicable rules when required to do so, this Agreement may be terminated by the City.

20. Records and Financial Audit.

The Contractor shall maintain detailed time and expenditure records that indicate the date; time, nature and cost of product(s) delivered, or services rendered during the Agreement's term and effect and retain them for a period of three (3) years from the date of final payment under this Agreement. The records shall be subject to inspection by the City, the Department of Finance and Administration and the State Auditor. The City shall have the right to audit billings both before and after payment. Payment under this Agreement shall not foreclose the right of the City to recover excessive or illegal payments

21. Disclaimer and Hold Harmless.

City of Rio Communities shall not be liable to the Contractor, or the Contractor's successors, heirs, administrators, or assigns, for any loss, damage, or injury, whether to Contractor's person or property, occurring in connection with Contractor's performance of Contractor's duties according to this Agreement. Contractor shall hold City of Rio Communities harmless from all loss, damage, and injury, including court costs and attorney fees, incurred by City of Rio Communities in connection with the performance by Contractor of Contractor's duties according to this Agreement.

22. Indemnification.

The Contractor shall defend, indemnify and hold harmless the City of Rio Communities from all actions, proceeding, claims, demands, costs, damages, attorneys' fees and all other liabilities and expenses of any kind from any source which may arise out of the performance of this Agreement, caused by the negligent act or failure to act of the Contractor, its officers, employees, servants, subcontractors or agents, or if caused by the actions of any client of the Contractor resulting in injury or damage to persons or property during the time when the Contractor or any officer, agent, employee, servant or subcontractor thereof has or is performing services pursuant to this Agreement. In the event that any action, suit or proceeding related to the services performed by the Contractor or any officer, agent, employee, servant or subcontractor under this Agreement is brought against the Contractor, the Contractor shall, as soon as practicable but no later than two (2) days after it receives notice thereof, notify the legal counsel of the City of Rio Communities and the New Mexico Association of Counties by certified mail.

23. Invalid Term or Condition.

If any term or condition of this Agreement shall be held invalid or unenforceable, the remainder of this Agreement shall not be affected and shall be valid and enforceable.

24. Enforcement of Agreement.

A party's failure to require strict performance of any provision of this Agreement shall not waive or diminish that party's right thereafter to demand strict compliance with that or any other provision. No waiver by a party of any of its rights under this Agreement shall be effective unless express and in writing, and no effective waiver by a party of any of its rights shall be effective to waive any other rights.

25. Authority.

If Contractor is other than a natural person, the individual(s) signing this Agreement on behalf of Contractor represents and warrants that he or she has the power and authority to bind Contractor, and that no further action, resolution, or approval from Contractor is necessary to enter into a binding contract.

26. Lobbying.

No federal appropriated funds can be paid or will be paid, by or on behalf of the CONTRACTOR, or any person for influencing or attempting to influence an officer or employee of any City, a Member of Congress, an officer or employee of Congress, or an employee of a Member of Congress in connection with the awarding of any Federal contract, or the making of any Federal grant, the making of any federal loan, the entering into of any cooperative agreement, or modification of any Federal contract, grant, loan, or cooperative agreement. If any funds other than federal appropriated funds have been paid or will be paid to any person influencing or attempting to influence an officer or employee of any City, a Member of Congress, an officer or employee of Congress, or an employee of a Member of Congress in connection of this federal contract, grant, loan, or cooperative agreement, the CONTRACTOR shall complete and submit Standard Form LLL, "Disclosure Form to Report Lobbying," in accordance with its instructions.

27. Non-Collusion.

In signing this bid the Bidder certifies he/she has not, either directly or indirectly, entered into action in restraint of free competitive bidding in connection with this offer submitted to the City.

28. Survival.

The Agreement paragraphs titled "Patent, Copyright, Trademark, and Trade Secret Indemnification" and "Indemnification" shall survive the expiration of this Agreement. Software licenses, leases, maintenance, and any other unexpired Agreements that were entered into under the terms and conditions of this Agreement shall survive this Agreement.

29. Succession.

This Agreement shall extend to and be binding upon the successors and assigns of the parties.

30. Force Majeure.

A party shall be excused from performance under this Agreement for any period that the party is prevented from performing as a result of an act of God, strike, war, civil disturbance, epidemic, or court order, provided that the party has prudently and promptly acted to take any and all steps that are within the party's control to ensure performance. Subject to this provision, such non-performance shall not be deemed a default or a ground for termination.

31. Mediation.

In the event a dispute arises as to the rights and obligations among the parties hereto, the parties agree to attempt to resolve the dispute through mediation as a condition

precedent to seeking legal and equitable remedies. The parties agree to evenly split the costs of any such mediation services. The parties shall mutually agree upon the choice of mediator. In the event the parties have not agreed upon a mediator within twenty (20) days of written notice to the other regarding the dispute, then a list of seven potential mediators will be obtained from the New Mexico Association of Counties and the parties shall utilize a striking process until a mediator is agreed upon.

32. Notice to Proceed.

It is expressly understood that this Agreement is not binding upon the City until it is executed by the Governing Body after voting on the Contract at a public meeting or unless it is executed by the City of Rio Communities City Manager, if the amount of the Contract is \$20,000.00 or less. Further, the Contractor is not to proceed with its obligations under the Agreement until the Contractor has received a fully executed copy of the Agreement and one or more valid Purchase Orders issued by the City.

33. Attorney's Fees.

In the event this Agreement results in dispute, mediation, litigation, or settlement between the parties to this Agreement, the prevailing party of such action shall NOT be entitled to an award of attorneys' fees and court costs.

34. Cooperation.

All parties hereto will fully cooperate with the other and their respective counsel, accountant, and agents in connection with any steps required to be taken under this Agreement.

35. Incorporation and Order of Precedence.

This Invitation for Bids and the Contractor's Bid Form are incorporated by reference into this Agreement and are made a part of this Agreement. In the event of any conflict among these documents, the following order of precedence shall apply:

1. Any Contract amendment(s), in reverse chronological order; then
2. this Contract itself; then
3. the Invitation for Bids; then
4. the Contractor's Bid Form; then
5. the Contractor's standard agreement terms and conditions (which may or may not have been submitted as part of the Contractor's bid).

36. Patent, Copyright, Trademark and Trade Secret Indemnification.

A. The Contractor shall defend, at its own expense, the City of Rio Communities against any claim that any product or service provided under this Agreement infringes any patent, copyright or trademark in the United States or Puerto Rico, and shall pay all costs, damages, and attorneys' fees that a court finally awards as a result of any such claim. In addition, if any third party obtains a judgment against the City of Rio

Communities based upon the Contractor's trade secret infringement relating to any product or service provided under this Agreement, the Contractor agrees to reimburse the City of Rio Communities for all costs, attorneys' fees and the amount of the judgment. To qualify for such defense and/or payment, the City of Rio Communities shall:

- i. give the Contractor prompt written notice of any claim;
 - ii. allow the Contractor to control the defense or settlement of the claim; and
 - iii. cooperate with the Contractor in a reasonable way to facilitate the defense or settlement of the claim.
- B. If any product or service becomes, or in the Contractor's opinion is likely to become the subject of a claim of infringement, the Contractor shall at its option and expense:
- i. provide a procuring agency of the City the right to continue using the product or service;
 - ii. replace or modify the product or service so that it becomes non-infringing;
- or
- iii. accept the return of the product or service and refund an amount equal to the depreciated value of the returned product or service, less the unpaid portion of the purchase price and any other amounts which are due to the Contractor. The Contractor's obligation will be void as to any product or service modified by the procuring agency of the City to the extent such modification is the cause of the claim.

37. Escalation Clause.

Price escalation due to increased cost to the Contractor is not allowed.

38. Warranties.

Contractor warrants the materials, supplies or services furnished to be exactly as specified, free from defects in Contractor's design, labor, materials and manufacture, and to be in compliance with any drawings or specifications incorporated herein and with any samples furnished by Contractor. Materials furnished by Contractor shall be accompanied by the manufacturer's written warranty against defects in quality, craftsmanship, and materials.

39. Commercial Warranty.

The Contractor agrees that the supplies or services furnished under this order shall be covered by the most favorable commercial warranties the Contractor gives for such to any customer for such supplies or services. The rights and remedies provided herein shall extend to the City and are in addition to and do not limit any rights afforded to the City by any other clause of this Agreement. Contractor agrees not to disclaim warranties of

fitness for a particular purpose of merchantability. Warranties shall become effective at the time of acceptance.

40. Inspection.

Final inspection and acceptance will be made at the destination. Supplies rejected at the destination for nonconformance with specifications shall be removed at the Contractor's risk and expense, promptly after notice of rejection.

41. Inspection of Plant.

The City may inspect, at any reasonable time, the part of the Contractor's, or any subcontractor's plant or place of business, which is related to the performance of this Contract.

42. Late Payment Charges.

Except as otherwise agreed to: late payment charges may be assessed against the user agency in the amount and under the conditions set forth in Section 13-1-158 NMSA 1978.

43. Overcharge Resulting from Antitrust Violations.

Contractor agrees that any and all claims for overcharge resulting from antitrust violations which are borne by the City as to goods, services, and materials purchased in connection with this bid are hereby assigned to the City.

44. Succession.

This Agreement shall extend to and be binding upon the successors and assigns of the parties.

45. Notices.

Any notice required to be given to either party by this Agreement shall be in writing and shall be delivered in person, by courier service or by U.S. mail, either first class or certified, return receipt requested, postage prepaid, as follows:

To the City: Angela R. Valadez, City of Rio Communities Procurement Officer
 360 Rio Communities Blvd.
 Rio Communities, NM 87002

To the Contractor: _____

IN WITNESS WHEREOF, the parties have executed this Agreement as of the date of signature of all parties.

CONTRACTOR

By: _____ Date: _____
Contractor

Printed Name: _____

Address: _____

CITY OF RIO COMMUNITIES

APPROVED, ADOPTED, AND PASSED on this ___ day of _____, 2023.

GOVERNING BODY OF THE CITY OF RIO COMMUNITIES

JOSHUA RAMSELL MAYOR

MARGARET "PEGGY" GUTJAHR
MAYOR PRO-TEM

ARTHUR APODACA
COUNCILOR

LAWRENCE GORDON
COUNCILOR

JIM WINTERS
COUNCILOR

ATTEST BY:

LALENA ARAGON, DEPUTY CLERK

By: _____ Date: _____
City of Rio Communities Procurement Officer

Attachment 1

Scope of Work

The CONTRACTOR shall deliver products and services to a Procuring Agency which issues a valid Purchase Order at prices not to exceed those shown in the Contractor's Bid Form (ITB 2023-0102 Appendix A). Procuring Agencies reserve the right to negotiate lower pricing upon mutual agreement of the parties.

APPENDIX B

BID FORM DRAINAGE IMPROVEMENTS

TO: Angela R. Valadez 360 Rio Communities
Rio Communities, NM 87002

The undersigned hereby proposes to perform all work for the Drainage Improvements Project in accordance with the following:

1. Advertisement for Bids dated 09/21/2023

2. All work required for the **DRAINAGE IMPROVEMENTS** project described in the Contract Documents shall be done in accordance with the New Mexico Department of Transportation Standard Specifications for Highway and Bridge Construction, current edition.

3. The Contract Documents, including Special Provisions, Supplementary Technical Specifications, and modifications as indicated.

All of which are incorporated herein and made a part hereof; and to perform said work in accordance with and at the rates and prices or lump sum bid shown in the following bid schedule. (Each item must be bid. The cost of any work added or deducted from the following estimated quantities shall be computed at the unit prices bid.) **Bids shall not include New Mexico gross receipts tax.**

DRAINAGE IMPROVEMENTS BID PROPOSAL BASE BID

BID ITEM	NMDOT ITEM NO.	ITEM DESCRIPTION	UNIT	ESTIMATED QTY	UNIT PRICE	AMOUNT
-------------	-------------------	---------------------	------	------------------	---------------	--------

BASE BID LOT

1	201000	CLEARING AND GRUBBING	LS	1	\$ 15,000.00	\$ 15,000.00
2	203000	UNCLASSIFIED EXCAVATION	C.Y.	100	\$ 45.00	\$ 4,500.00
3	303000	BASE COURSE	TON	45	\$ 50.00	\$ 2,250.00
4	408100	PRIME COAT MATERIAL	TON	1	\$ 1,500.00	\$ 1,500.00
5	416104	MINOR PAVING TYPE I, HMA SP-IV	TON	30	\$ 165.00	\$ 4,950.00
6	515000	REINF. CONCRETE FOR MINOR STRUCTURES	C.Y.	2	\$ 1,500.00	\$ 3,000.00
7	541200	STRUCTURAL STEEL FOR MISCELLANEOUS STRUCTURES	LB	160	\$ 100.00	\$ 16,000.00
8	570437	24" STORM DRAIN CULVERT	L.F.	10	\$ 180.00	\$ 1,800.00

9	601110	REMOVAL OF SURFACING	S.Y.	150	\$ 15.00	\$ 2,250.00
10	602000	RIP RAP CALSS A	C.Y.	100	\$ 300.00	\$ 30,000.00
11	609424	CONCRETE VERTICAL CURB AND GUTTER TYPE B	L.F.	100	\$ 70.00	\$ 7,000.00
12	609636	CONCRETE VALLEY GUTTER	L.F.	35	\$ 50.00	\$ 1,750.00
13	618000	TRAFFIC CONTROL MANAGEMENT	LS	1	\$ 7,500.00	\$ 7,500.00
14	621000	MOBILIZATION	LS	1	\$ 30,000.00	\$ 30,000.00
15	662022	MANHOLE TYPE C-DEPTH	EACH	1	\$ 12,000.00	\$ 12,000.00
16	801000	CONSTRUCTION STAKING BY THE CONTRACTOR	LS	1	\$ 15,000.00	\$ 15,000.00
17	802000	POST CONSTRUCTION PLANS	LS	1	\$ 3,000.00	\$ 3,000.00

\$ 157,500.00

Write out Base Bid Amount:

One hundred fifty seven thousand
five hundred dollars

a) **Base Bid** Subtotal of Bid Items No. 1 through 17 \$ 157,500

b) **Allowances:**
\$ 10,000.00 _____

Total Allowances: \$ 10,000.00

c) **Subtotal** Base Bid subtotal plus Allowances: \$ 167,500

d) **New Mexico Gross Receipts Tax (NMGRT)**
on amount online c) Subtotal at 8.3000%: \$ 13,902.50

e) **BASE BID TOTAL** Line c) Subtotal plus Line d) NMGRT: \$ 181,402.5

One hundred eighty one thousand four
hundred two and fifty cents Dollars (Total amount written in words)

The undersigned, as Bidder, hereby declares that the only persons or firms interested in the proposal as principals are named herein; that no other persons or firms have any interest in this proposal or in the contract to be entered into; that this proposal is made without collusion with any other person, company, or parties making a bid; and that it is in all respects fair and in good faith, without collusion or fraud.

The Contractor agrees that should he fail to complete the project in 60 calendar days, he agrees to pay as liquidated damages the amount of three hundred dollars (\$300.00) per calendar day for each day exceeding the contract substantial completion date, representing monetary damage and risk to property or life. The Contractor further agrees that any extensions in the contract time shall apply only to the date of completion for the entire contract. Attached hereto is the required proposal guarantee described as follows:

The proposal guarantee shall be 5% of the total amount bid. The receipt of Addenda is acknowledged below:

Addendum No. 1 Date 9/12/2023

Addendum No. 2 Date 9/13/2023

Addendum No. 3 Date 9/18/2023

Dated: September 21, 2023.

SIGNATURE OF BIDDER

(SEAL) if Bid is by a Corporation

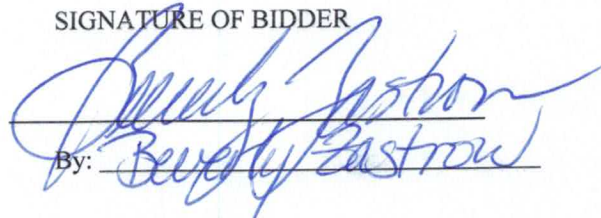
By: Beverly Zastrow

(Print Name) Beverly Zastrow

Title: Managing Member

Company: Desert Fox, LLC

Date: September 21, 2023

Address: P O Box 1499, Peralta, NM
87042

New Mexico Contractor's Classification and License No. GA1, GA4
367698

Resident Bidder Preference Certification
No. L0133728688
(if applicable)

APPENDIX C

LETTER OF TRANSMITTAL FORM

Items #1 to 4 MUST EACH BE RESPONDED TO. Failure to respond to all four items
WILL RESULT IN THE DISQUALIFICATION OF THE BID!

1. Identity (Name) and Mailing Address of the submitting organization:

Desert Fox, LLC
PO Box 1499
Peralta, NM 87042

2. For the person submitting the bid:

Name	Beverly Zastrow
Title	Managing Member
E-Mail Address	desertfoxpaving@yahoo.com
Telephone Number	505-892-5400

3. Bidder must identify any employee(s) or elected official(s) of City of Rio Communities that have a financial interest in the Bidder (one of the two **must** be selected):

No Financial Interest Yes, Financial
Interest*

*Specify by name(s): _____

4. Declarations:

- I certify that I am authorized to contractually bind my company.
- On behalf of the submitting organization named in item #1, above, I accept the Conditions Governing the Procurement as required in Section II, Paragraph C.1. and agree to the Terms and Conditions of the Contract provided in Appendix G.
- I acknowledge receipt of any and all amendments to this ITB.
- I certify that my company/entity/organization commits to comply and act in accordance with (1) Federal Executive Orders and New Mexico State Statutes relating to the enforcement of civil rights, (2) Federal Code 5 USCA 7201 et. seq., Anti-Discrimination in Employment; (3) Executive Order No. 11246, Equal Opportunity in Federal Employment; (4) Title 6, Civil Rights Act of 1964; and (5) Requirements of the American with Disabilities Act of 1990 for work performed as a result of this ITB.

September 27, 2023
Authorized Signature and Date (Must be signed by the person identified in item #2, above.)

Pursuant to NMSA 1978, § 13-1-191.1 (2006), any person seeking to enter into a contract with any state agency or local public body **for professional services, a design and build project delivery system, or the design and installation of measures the primary purpose of which is to conserve natural resources** must file this form with that state agency or local public body. This form must be filed even if the contract qualifies as a small purchase or a sole source contract. The prospective contractor must disclose whether they, a family member or a representative of the prospective contractor has made a campaign contribution to an applicable public official of the state or a local public body during the two years prior to the date on which the contractor submits a proposal or, in the case of a sole source or small purchase contract the two years prior to the date the contractor signs the contract, if the aggregate total of contributions given by the prospective contractor, a family member or a representative of the prospective contractor to the public official exceeds two hundred and fifty dollars (\$250) over the two-year period. Furthermore, the state agency or local public body shall void an executed contract or cancel a solicitation or proposed award for a proposed contract if: 1) a prospective contractor, a family member of the prospective contractor, or a representative of the prospective contractor gives a campaign contribution or other thing of value to an applicable public official or the applicable public official's employees during the pendency of the procurement process or 2) a prospective contractor fails to submit a fully completed disclosure statement pursuant to the law.

THIS FORM MUST BE FILED BY ANY PROSPECTIVE CONTRACTOR WHETHER OR NOT THEY, THEIR FAMILY MEMBER, OR THEIR REPRESENTATIVE HAS MADE ANY CONTRIBUTIONS SUBJECT TO DISCLOSURE.

The following definitions apply:

"Applicable public official" means a person elected to an office or a person appointed to complete a term of an elected office, who has the authority to award or influence the award of the contract for which the prospective contractor is submitting a competitive sealed proposal or who has the authority to negotiate a sole source or small purchase contract that may be awarded without submission of a sealed competitive proposal.

"Campaign Contribution" means a gift, subscription, loan, advance or deposit of money or other thing of value, including the estimated value of an in-kind contribution, that is made to or received by an applicable public official, or any person authorized to raise, collect or expend contributions on that official's behalf for the purpose of electing the official to either

statewide or local office.

"Campaign Contribution" includes the payment of a debt incurred in an election campaign, but does not include the value of services provided without compensation or unreimbursed travel or other personal expenses of individuals who volunteer a portion or

all of their time on behalf of a candidate or political committee, nor does it include the administrative or solicitation expenses of a political committee that are paid by an organization that sponsors the committee.

"Family member" means spouse, father, mother, child, father-in-law, mother-in-law, daughter-in-law, or son-in-law.

"Pendency of the procurement process" means the time period commencing with the public notice of the request for proposals and ending with the award of the contract or the cancellation of the request for proposals.

"Person" means any corporation, partnership, individual, joint venture, association or any other private legal entity.

"Prospective contractor" means a person who is subject to the competitive sealed proposal process set forth in the Procurement Code or is not required to submit a competitive sealed proposal because that person qualifies for a sole source or a small purchase contract.

"Representative of a prospective contractor" means an officer or director of a corporation, a member or manager of a limited liability corporation, a partner of a partnership or a trustee of a trust of the prospective contractor.

DISCLOSURE OF CONTRIBUTIONS: _____

Contribution Made By: _____

Relation to Prospective Contractor: _____

Name of Applicable Public Official: _____

Date Contribution(s) Made: _____

Amount(s) of Contribution(s) _____

Nature of Contribution(s) _____

Purpose of Contribution(s)
(Attach extra pages if necessary) _____

Signature

Date

Title (position)
-OR-

NO CONTRIBUTIONS IN THE AGGREGATE TOTAL OVER TWO HUNDRED FIFTY DOLLARS (\$250) WERE MADE to an applicable public official by me, a family member or representative.

Signature 

Date *September 21, 2003*

Title (Position) *Managing Member*
Managing Member

APPENDIX E

_____(NAME OF CONTRACTOR) hereby certifies the procurement:

Please check one box only

ending December 31 is less than \$1M allowing me the 10% preference discount on this solicitation. I understand that knowingly giving false or misleading information about this fact constitutes a crime.

following in regard to application of the resident veterans' preference to this

I declare under penalty of perjury that my business prior year revenue starting January

APPENDIX E

Desert Fox, LLC

(NAME OF CONTRACTOR) hereby certifies the procurement:

Please check one box only

Ending December 31 is less than \$1M allowing me the 10% preference discount on this solicitation. I understand that knowingly giving false or misleading information about this fact constitutes a crime. following in regard to application of the resident veterans' preference to this

I declare under penalty of perjury that my business prior year revenue starting January

prior year revenue starting January 1 ending December 31 is more than \$1M but less than \$5M allowing me the 8% preference discount on this bid or proposal. I understand that knowingly giving false or misleading information about this fact constitutes a crime.

Ending December 31 is more than \$5M allowing me the 7% preference discount on this bid or proposal. I understand that knowingly giving false or misleading information about this fact constitutes a crime.

Services Department declaring under penalty of perjury that during the last calendar year starting January 1 and ending on December 31, the following to be true and accurate:

for a Resident Veteran Business Preference/Resident Veteran Contractor Preference under Sections 13-1-21 or 13-1-22 NMSA 1978, when awarded a contract which was on the basis of having such preference, I agree to report to the State Purchasing Division of the General Services Department the awarded amount involved. I will indicate in the report the award amount as a purchase from a public body or as a public works contract from a public body as the case may be.

I declare under penalty of perjury that this statement is true to the best of my knowledge. I understand that giving false or misleading statements about material fact regarding this matter constitutes a crime.

"I understand that knowingly giving false or misleading information on this report constitutes a crime."

(Signature of Business Representative) * _____ (Date) _____

*Must be an authorized signatory for the Business.

The representations made in checking the boxes constitutes a material representation by the business that is subject to protest and may result in denial of an award or unaward of the procurement involved if the statements are proven to be incorrect.

CITY OF RIO COMMUNITIES DRAINAGE IMPROVEMENTS



VALENCIA COUNTY, NEW MEXICO CITY PROJECT NO. L300288

INDEX OF SHEETS	
SHEET NUMBER	DESCRIPTION
SECTION-1	
1 - 1	COVER, VICINITY MAP AND INDEX OF SHEETS
1 - 2	SUMMARY OF QUANTITIES
1 - 3	GENERAL NOTES
	SUBTOTAL: 3
SECTION-2	
2 - 1	EXISTING TYPICAL SECTIONS
2 - 2	PROPOSED TYPICAL SECTIONS
2 - 3	SURFACING SCHEDULE
2 - 4	MISCELLANEOUS QUANTITIES & ESTIMATED STRUCTURE QUANTITIES
2 - 5	MISCELLANEOUS DETAILS
	SUBTOTAL: 5
SECTION-3	
3 - 1	OVERALL PROJECT SURVEY CONTROL PLAN & HORIZONTAL LAYOUT
3 - 2	SURVEY CONTROL MAP
3 - 3	ROADWAY PLAN
	SUBTOTAL: 3
SECTION-4	
	NO SHEETS
	SUBTOTAL: 0
SECTION-5	
	NO SHEETS
	SUBTOTAL: 0
SECTION-6	
	NO SHEETS
	SUBTOTAL: 0
SECTION-7	
	NO SHEETS
	SUBTOTAL: 0

INDEX OF SHEETS	
SHEET NUMBER	DESCRIPTION
SECTION-8	
	NO SHEETS
	SUBTOTAL: 0
SECTION-9	
	NO SHEETS
	SUBTOTAL: 0
SECTION-10	
10 - 1	DITCH PLAN AND PROFILE
10 - 2	STORM DRAIN LATERAL PROFILES
	SUBTOTAL: 2
SECTION-11	
	NO SHEETS
	SUBTOTAL: 0
SECTION-12	
	NO SHEETS
	SUBTOTAL: 0
SECTION-13	
	NO SHEETS
	SUBTOTAL: 0
SECTION-14	
	NO SHEETS
	SUBTOTAL: 0
	TOTAL: 13



VICINITY MAP



CALL NM ONE-CALL
SYSTEM SEVEN (7) DAYS
PRIOR TO ANY EXCAVATION



2155 LOUISIANA BLVD NE,
SUITE 3000
ALBUQUERQUE, NM 87110
(505) 830-5400



AUG 28, 2023

DATE: 28 Aug 2023 - 3:16pm USER: ANGONZALEZ



CITY OF RIO COMMUNITIES

SUMMARY OF QUANTITIES										
NMDOT ITEM NO.	SHORT DESCRIPTION	UNIT	ROADWAY		CONSTRUCTION ENGINEERING		DRAINAGE		PROJECT TOTAL	
			ESTIMATE	FINAL	ESTIMATE	FINAL	ESTIMATE	FINAL	ESTIMATE	FINAL
			201000	CLEARING AND GRUBBING	LS	LS				
203000	UNCLASSIFIED EXCAVATION	C.Y.	100							100
303000	BASE COURSE	TON	45							45
408100	PRIME COAT MATERIAL	TON	1							1
416104	MINOR PAVING TYPE I, HMA SP-IV	TON	30							30
515000	REINF. CONCRETE FOR MINOR STRUCTURES	C.Y.					2			2
541200	STRUCTURAL STEEL FOR MISCELLANEOUS STRUCTURES	LB					160			160
570437	24" STORM DRAIN CULVERT PIPE	L.F.					10			10
601110	REMOVAL OF SURFACING	S.Y.	150							150
602000	RIPRAP CLASS A	C.Y.					100			100
609424	CONCRETE VERTICAL CURB AND GUTTER TYPE B 6" X 24"	L.F.	900							900
609636	CONCRETE VALLEY GUTTER 6" X 36"	L.F.	35							35
618000	TRAFFIC CONTROL MANAGEMENT	LS			LS					LS
621000	MOBILIZATION	LS	LS							LS
662022	MANHOLE TYPE C-6' DIAMETER OVER 6' TO 10' DEPTH	EACH					1			1
801000	CONSTRUCTION STAKING BY THE CONTRACTOR	LS			LS					LS
802000	POST CONSTRUCTION PLANS	LS			LS					LS

NO.	DESCRIPTION	DATE	BY
4			
3			
2			
1			

CN L300288
RIO COMMUNITIES DRAINAGE IMPROVEMENTS
SUMMARY OF QUANTITIES



DATE: 28 Aug 2023 - 3:16pm USER: ANGONZALEZ

GENERAL NOTES

1. **SPECIFICATIONS** : ALL WORK DETAILED ON THESE PLANS TO BE PERFORMED UNDER CONTRACT, EXCEPT AS OTHERWISE STATED OR PROVIDED FOR HEREON, SHALL BE CONSTRUCTED IN ACCORDANCE WITH THE NEW MEXICO DEPARTMENT OF TRANSPORTATION (NMDOT) STANDARD SPECIFICATIONS FOR HIGHWAY AND BRIDGE CONSTRUCTION, 2019 EDITION.
2. **GENERAL** : THE CONTRACTOR SHALL ABIDE BY ALL LOCAL, STATE, AND FEDERAL LAWS, RULES AND REGULATIONS WHICH APPLY TO THE CONSTRUCTION OF THESE IMPROVEMENTS.
3. **RESIDENCE ACCESS** : THE CONTRACTOR SHALL PROVIDE INGRESS AND EGRESS TO LOCAL RESIDENCES FOR THE DURATION OF THE PROJECT. THE CONTRACTOR SHALL ADVISE OF AND SCHEDULE ACCESS CLOSURES AT LEAST 24 HOURS IN ADVANCE, WITH PROPERTY OWNERS AND THE CITY MANAGER. THIS WORK WILL BE CONSIDERED INCIDENTAL TO ITEM NO. 618000 TRAFFIC CONTROL MANAGEMENT.
4. **CONSTRUCTION SCHEDULE** : TEN (10) WORKING DAYS PRIOR TO BEGINNING CONSTRUCTION, THE CONTRACTOR SHALL SUBMIT TO THE CITY OF RIO COMMUNITIES (CITY) A DETAILED CONSTRUCTION SCHEDULE.
5. THE CONTRACTOR SHALL NOT BEGIN WORK BEFORE 7:00 A.M. NOR CONTINUE WORK AFTER 6:00 P.M. WITHOUT THE APPROVAL OF THE CITY MANAGER.
6. **NM ONE-CALL**: TWO (2) WORKING DAYS PRIOR TO ANY EXCAVATION, THE CONTRACTOR SHALL CONTACT THE NEW MEXICO ONE CALL SYSTEM (505-260-1990) FOR LOCATION OF EXISTING UTILITIES.
7. **PERMITS** : THE CONTRACTOR SHALL OBTAIN ALL THE NECESSARY PERMITS FOR THE PROJECT PRIOR TO COMMENCING CONSTRUCTION.
8. **OVERNIGHT PARKING** : OVERNIGHT PARKING OF CONSTRUCTION EQUIPMENT SHALL NOT OBSTRUCT DRIVEWAYS OR DESIGNATED TRAFFIC LANES. THE CONTRACTOR SHALL NOT STORE ANY EQUIPMENT OR MATERIAL WITHIN THE PUBLIC RIGHT-OF-WAY.
9. **SURVEY MONUMENTS** : THE CONTRACTOR SHALL NOTIFY THE CITY NOT LESS THAN SEVEN (7) DAYS PRIOR TO STARTING WORK IN ORDER THAT THE CITY MAY TAKE NECESSARY MEASURES TO ENSURE THE PRESERVATION OF SURVEY MONUMENTS. CONTRACTOR SHALL NOT DISTURB PERMANENT SURVEY MONUMENTS WITHOUT THE CONSENT OF THE CITY AND SHALL NOTIFY THE CITY AND BEAR THE EXPENSE OF REPLACING ANY THAT MAY BE DISTURBED WITHOUT PERMISSION. WHEN A CHANGE IS MADE IN THE FINISHED ELEVATION OF THE PAVEMENT OF ANY ROADWAY IN WHICH A PERMANENT SURVEY MONUMENT IS LOCATED, CONTRACTOR SHALL, AT HIS OWN EXPENSE, ADJUST THE MONUMENT COVER TO THE NEW GRADE UNLESS OTHERWISE SPECIFIED.
10. **CONSTRUCTION LIMITS** : CONSTRUCTION ACTIVITY SHALL BE LIMITED TO THE PUBLIC RIGHT-OF-WAY AND/OR PROJECT LIMITS. ANY DAMAGE TO ADJACENT PROPERTIES RESULTING FROM THE CONSTRUCTION PROCESS IS THE RESPONSIBILITY OF THE CONTRACTOR. ANY COSTS INCURRED FOR REPAIRS SHALL BE AT THE COST OF THE CONTRACTOR.
11. **BUILDING DAMAGE** : IT SHALL BE THE CONTRACTOR'S RESPONSIBILITY TO ENSURE THAT BUILDING STRUCTURES ADJACENT TO THE PROJECT NOT BE DAMAGED DUE TO ANY CONSTRUCTION ACTIVITIES. DAMAGE CAUSED TO ANY BUILDING STRUCTURE WILL BE THE SOLE RESPONSIBILITY OF THE CONTRACTOR, INCLUDING ALL COSTS INCURRED IN RESTORING/REPAIRING SAID DAMAGE.
12. **AS-BUILTS** : THE CONTRACTOR SHALL MAINTAIN AN UP TO DATE SET OF AS-BUILT PLANS FOR THE PROJECT. THESE PLANS SHALL BE KEPT CURRENT, WITHIN TWO WEEKS, AT ALL TIMES AND SHALL BE SUBJECT TO THE REVIEW BY THE PROJECT MANAGER THROUGHOUT THE PROJECT AND WILL BE REVIEWED BY THE PROJECT MANAGER FOR ACCURACY AND COMPLETENESS AT LEAST ONCE EVERY 30 DAYS. THE FINAL AS-BUILT PLANS SHALL BE SUBMITTED AND ACCEPTED BY THE PROJECT ENGINEER PRIOR TO FINAL PAYMENT. AS-BUILT PLANS SHALL BE INCIDENTAL TO ITEM NO. 802000 POST CONSTRUCTION PLANS.
13. **GRAFFITI** : THE CONTRACTOR SHALL MAINTAIN A GRAFFITI-FREE WORK SITE AND SHALL PROMPTLY REMOVE ANY AND ALL GRAFFITI FROM ALL EQUIPMENT, FACILITIES, APPURTENANCES, AND ANY AND ALL BARRICADING AND SIGNAGE ASSOCIATED WITH THE PROJECT WHETHER PERMANENT OR TEMPORARY. THIS WORK SHALL BE CONSIDERED INCIDENTAL TO THE PROJECT AND NO SEPARATE MEASUREMENT OR PAYMENT WILL BE MADE THEREFOR. THIS WORK WILL BE CONSIDERED INCIDENTAL TO ITEM NO. 618000 TRAFFIC CONTROL MANAGEMENT.
14. **CONSTRUCTION SIGNAGE** : THE CONTRACTOR SHALL BE RESPONSIBLE FOR PROVIDING AND MAINTAINING ALL CONSTRUCTION SIGNAGE UNTIL THE PROJECT HAS BEEN ACCEPTED BY THE CITY OF RIO COMMUNITIES.
15. **NON-VIBRATORY ROLLER** : THE CONTRACTOR SHALL BE RESTRICTED TO THE USE OF A 35 TON MAXIMUM NON-VIBRATORY ROLLER TO OBTAIN THE REQUIRED COMPACTION IN PAVEMENT STRUCTURE, ROADWAY BACKFILL, EMBANKMENT, AND SUBGRADES IN RESIDENTIAL AREAS WHERE THE USE OF HEAVIER EQUIPMENT COULD DAMAGE UNDERGROUND UTILITIES OR OTHER PERMANENT STRUCTURES.
16. **EXISTING TIE-IN** : ALL NEW STREET PAVING, CURB AND GUTTER, SIDEWALKS OR DRIVEPADS SHALL MATCH THE ELEVATIONS OF ABUTTING EXISTING AREAS AS SHOWN IN THE PLANS OR AS DIRECTED BY THE PROJECT MANAGER.
17. **DAMAGE REPAIR** : THE CONTRACTOR SHALL ASSUME RESPONSIBILITY FOR ANY DAMAGE TO EXISTING PAVEMENTS, PAVEMENT MARKINGS, CURB & GUTTER, DRIVE PADS, CURB RAMPS, SIGNAGE, AND SIDEWALK DURING CONSTRUCTION, APART FROM THOSE SECTIONS INDICATED FOR REMOVAL ON THE PLANS AND SHALL REPAIR OR REPLACE PER NMDOT STANDARDS, AT THEIR OWN EXPENSE.
18. **OSHA REQUIREMENTS** : ALL EXCAVATION, TRENCHING, AND SHORING ACTIVITIES MUST BE CARRIED-OUT IN ACCORDANCE WITH OSHA 29 CFR 1926.652.
19. **MATCHING EXISTING GRADES** : WHERE A PROFILE GRADE IS NOT PROVIDED IN THE PLANS, STREET CENTERLINE GRADES SHALL BE RESTORED BY THE CONTRACTOR TO THE EXISTING CENTERLINE GRADES. CROSS SECTION THE EXISTING ROAD PRIOR TO CONSTRUCTION AS NEEDED TO MATCH EXISTING (50' MIN). MINOR ADJUSTMENTS TO THE STREET GRADES MAY BE NECESSARY AND WILL BE DIRECTED BY THE PROJECT ENGINEER. MINOR ADJUSTMENTS TO THE STREET GRADES WILL BE CONSIDERED INCIDENTAL TO THE PAVING BID ITEMS. SMOOTH TRANSITIONS SHALL BE MADE BETWEEN EXISTING PAVEMENT WHICH REMAINS IN PLACE AND PAVEMENT WHICH IS BEING REPLACED. TRAFFIC CONTROL DEVICES INCLUDING PAVEMENT MARKINGS MUST BE RESTORED TO THE SAME OR BETTER CONDITION AS BEFORE CONSTRUCTION. THIS WORK WILL BE CONSIDERED INCIDENTAL TO ITEM NO. 416104 MINOR PAVING TYPE I, HMA SP-IV.
20. **HUMAN REMAINS** : IF HUMAN REMAINS ARE ENCOUNTERED, THE CONTRACTOR SHALL CEASE ALL WORK, AND NOTIFY THE CITY OF RIO COMMUNITIES FOR FURTHER INSTRUCTIONS.
21. **DROP-OFF POLICY** : IF A PAVEMENT DROP-OFF IS CREATED DURING CONSTRUCTION, THE CONTRACTOR SHALL INITIATE PROTECTIVE ACTION TO MAINTAIN A SMOOTH TRANSITION. THIS WORK SHALL BE CONSIDERED INCIDENTAL TO ITEM NO. 618000 TRAFFIC CONTROL MANAGEMENT, AND NO SEPARATE MEASUREMENT OR PAYMENT WILL BE MADE THEREFOR.
22. **PUBLIC INFORMATION** : COORDINATION WITH THE CITY PUBLIC INFORMATION OFFICE (PIO), WHO WILL ADVISE THE PUBLIC OF CONSTRUCTION FOR THE DURATION OF THE PROJECT. ANY IMPACT TO THE ACCESS OF BUSINESSES SHALL BE COORDINATED SEVEN (7) DAYS IN ADVANCE WITH THE CITY AND BUSINESSES.
23. **UTILITY REPAIR** : THE CONTRACTOR IS RESPONSIBLE FOR PROTECTING THE EXISTING UTILITY LINES WITHIN THE CONSTRUCTION AREA. ANY DAMAGE TO EXISTING FACILITIES CAUSED BY CONSTRUCTION ACTIVITY SHALL BE REPAIRED OR REPLACED AT THE CONTRACTOR'S EXPENSE AND APPROVED BY THE CITY.
24. ALL ELECTRICAL, TELEPHONE, CABLE TV, GAS AND OTHER UTILITY LINES, CABLES AND APPURTENANCES ENCOUNTERED DURING CONSTRUCTION THAT REQUIRE RELOCATION, SHALL BE COORDINATED WITH THAT UTILITY. THE CONTRACTOR SHALL BE RESPONSIBLE FOR COORDINATION OF ALL NECESSARY UTILITY ADJUSTMENTS. NO ADDITIONAL COMPENSATION WILL BE ALLOWED FOR DELAYS OR INCONVENIENCES CAUSED BY UTILITY COMPANY WORK CREWS. THE CONTRACTOR MAY BE REQUIRED TO RESCHEDULE THEIR ACTIVITIES TO ALLOW UTILITY CREWS TO PERFORM THEIR REQUIRED WORK.
25. **DISPOSAL SITE** FOR ALL EXCESS EXCAVATION MATERIAL, AND UNSUITABLE MATERIAL SHALL BE OBTAINED BY THE CONTRACTOR IN COMPLIANCE WITH APPLICABLE ENVIRONMENTAL REGULATIONS AND APPROVED BY THE CITY. ALL COSTS INCURRED IN OBTAINING A DISPOSAL SITE AND HAUL THERETO SHALL BE CONSIDERED INCIDENTAL TO ITEM NO. 203000 UNCLASSIFIED EXCAVATION, AND NO SEPARATE MEASUREMENT OR PAYMENT WILL BE MADE.
26. THE CONTRACTOR SHALL COORDINATE WITH THE CITY PRIOR TO BEGINNING ANY CONSTRUCTION WORK ON OR ADJACENT TO EXISTING STREETS.
27. ALL BARRICADES AND CONSTRUCTION SIGNING SHALL CONFORM TO APPLICABLE SECTIONS OF THE "MANUAL ON UNIFORM TRAFFIC CONTROL DEVICES" (MUTCD), U.S. DEPARTMENT OF TRANSPORTATION, LATEST EDITION.
28. THE CONTRACTOR SHALL MAINTAIN ALL CONSTRUCTION BARRICADES AND SIGNING AT ALL TIMES. THE CONTRACTOR SHALL VERIFY THE PROPER LOCATION OF ALL BARRICADING AT THE END AND BEGINNING OF EACH DAY.
29. ALL SAWCUT PAVEMENT SHALL HAVE A UNIFORM EDGE AND BE SPRAYED WITH TACK COAT. THIS WORK WILL BE CONSIDERED INCIDENTAL TO ITEM NO. 416104 MINOR PAVING TYPE I, HMA SP-IV.
30. PRIOR TO CONSTRUCTION, THE CONTRACTOR SHALL EXCAVATE AND VERIFY THE HORIZONTAL AND VERTICAL LOCATIONS OF ALL POTENTIAL OBSTRUCTIONS. SHOULD A CONFLICT EXIST, THE CONTRACTOR SHALL NOTIFY THE CITY INSPECTOR IMMEDIATELY SO THE CONFLICT CAN BE RESOLVED WITH A MINIMUM AMOUNT OF DELAY.
31. IF THE CONTRACTOR IS NOT ALLOWED TO WORK AT NIGHT DUE TO THE CITY'S NOISE ORDINANCE, THE CONTRACTOR SHALL OPEN ALL TRAFFIC LANES TO TRAFFIC WITH PROPER USE OF TRENCH PLATES DURING NON-WORKING HOURS, UNLESS PERMITTED BY CONSTRUCTION PROJECT MANAGER.
32. THE CONTRACTOR SHALL RECORD DATA ON ALL UTILITY LINES AND ACCESSORIES AS REQUIRED BY THE CITY FOR THE PREPARATION OF "AS-BUILT" DRAWINGS. CONTRACTOR SHALL NOT COVER UTILITY LINES AND ACCESSORIES UNTIL ALL DATA HAS BEEN RECORDED.
33. **SALVAGEABLE MATERIALS** : SALVAGEABLE MATERIALS FROM THIS PROJECT ARE TO BE HAULED AND STOCKPILED AT THE CITY PROPERTY INDICATED BY THE CITY MANAGER. HAUL OF SUCH MATERIAL SHALL BE PERFORMED DURING NORMAL WORKING HOURS AS DIRECTED BY THE PROJECT MANAGER. PAYMENT FOR THIS WORK WILL BE CONSIDERED INCIDENTAL TO ITEM NO. 201000 CLEARING AND GRUBBING.
34. **ADJACENT LANDSCAPING** TO BE PROTECTED BY THE CONTRACTOR AND NO SEPARATE PAYMENT WILL BE MADE. CONTRACTOR SHALL TAKE VIDEO AND PHOTOS OF ALL EXISTING LANDSCAPING. DAMAGE TO EXISTING LANDSCAPING SHALL BE REPLACED IN KIND BY CONTRACTOR WITH NO SEPARATE PAYMENT.
35. IF EXISTING FIBER OPTIC OR ANY OTHER EXISTING CITY TRAFFIC INFRASTRUCTURE IS DAMAGED AS PART OF THIS PROJECT WORK, THE CONTRACTOR SHALL REPAIR IT OR REPLACE IT PER CITY TRAFFIC REQUIREMENTS. DAMAGED FIBER OPTIC CABLE SHALL BE REPLACED FROM EXISTING FULL SPLICE TO EXISTING FULL SPLICE; NO INTERMEDIATE SPLICE WILL BE ALLOWED. THIS WORK SHALL BE DONE AT THE EXPENSE OF THE CONTRACTOR AND NO ADDITIONAL PAYMENT WILL BE MADE.
36. AT ALL PAVEMENT REMOVAL AND REPLACEMENTS, SAW-CUT EDGES SHALL BE STRAIGHT AND CLEAN, AND LONGITUDINAL JOINTS SHALL NOT BE PLACED WITHIN WHEEL PATHS. PATCHES SHALL BE REGULAR AND SQUARE OR RECTANGULAR, WITH FOUR STRAIGHT SIDES. FINISHED PAVEMENT SURFACE SHALL BE FLUSH WITH EXISTING PAVEMENT SURFACE, WITH NO SPILLOVER OF ASPHALT OR TACK COAT. CARE MUST BE TAKEN TO AVOID DAMAGING THE INTEGRITY OR APPEARANCE OF SURROUNDING PAVEMENTS; IF DAMAGED, THE ENTIRE SURFACE PATCH MUST BE EXPANDED TO COVER DAMAGES AT THE CONTRACTOR'S EXPENSE.
37. THE CONTRACTOR SHALL DESIGNATE AT LEAST ONE EMERGENCY CONTACT PERSON, AND SHALL PROVIDE TELEPHONE NUMBERS WHERE THIS PERSON CAN BE CONTACTED AT ANY TIME. THIS INFORMATION SHALL BE PROVIDED TO THE CITY'S PROJECT MANAGER.
38. THE CONTRACTOR SHALL SUBMIT A TRAFFIC CONTROL PLAN FOR WORK WITHIN THE PUBLIC RIGHT-OF-WAY SHOWING ALL TEMPORARY TRAFFIC CONTROL DEVICES FOR EACH PHASE OF WORK. THE PLAN SHALL SHOW EACH INDIVIDUAL PHASE OF THE PROJECT WITH A SCHEDULE AND MAP SHOWING PLACEMENT AND DESCRIPTION OF EACH TEMPORARY TRAFFIC CONTROL DEVICE. THE "TRAFFIC CONTROL PLAN" SHALL COMPLY WITH THE MANUAL ON UNIFORM TRAFFIC CONTROL DEVICES. THIS WORK WILL BE CONSIDERED INCIDENTAL TO ITEM NO. 618000 TRAFFIC CONTROL MANAGEMENT.



CITY OF RIO COMMUNITIES

NO.	DESCRIPTION	DATE	BY
4			
3			
2			
1			
NO.			

RIO COMMUNITIES DRAINAGE IMPROVEMENTS
GENERAL NOTES

CN L300288



DATE: 28 Aug 2023 - 3:16pm USER: ANGONZALEZ

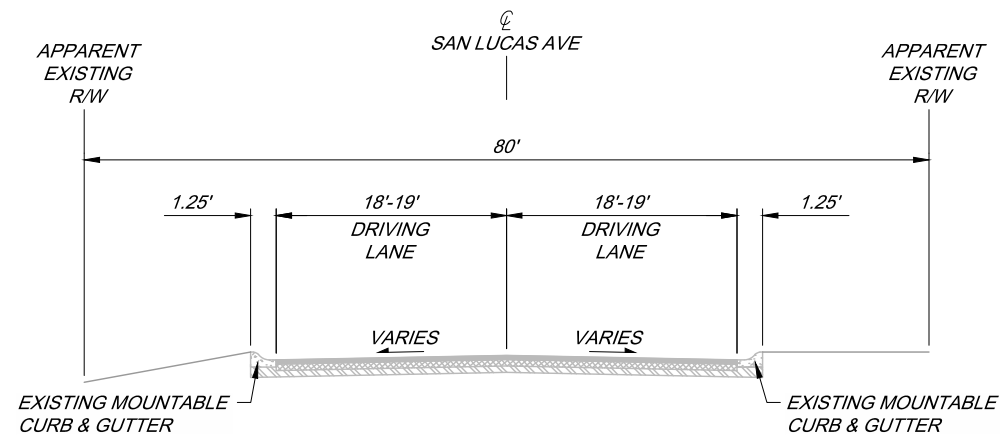

EXISTING TYPICAL SECTION 1: SAN LUCAS AVE
STA. 10+00.00 TO STA. 15+44.16

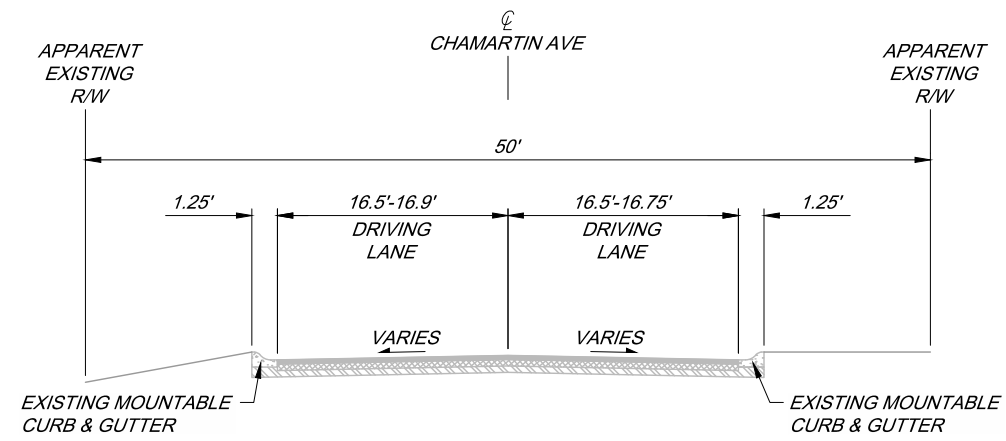

EXISTING TYPICAL SECTION 1: CHAMARTIN AVE
STA. 20+45.87 TO STA. 21+20.85

TRANSITION
STA. 20+18.20 TO STA. 20+45.87

CITY OF RIO COMMUNITIES

NO.	DESCRIPTION	DATE	BY
4			
3			
2			
1			

CN L300288
RIO COMMUNITIES DRAINAGE IMPROVEMENTS
EXISTING TYPICAL SECTIONS



DATE: 28 Aug 2023 - 3:16pm USER: ANGONZALEZ



CITY OF RIO COMMUNITIES

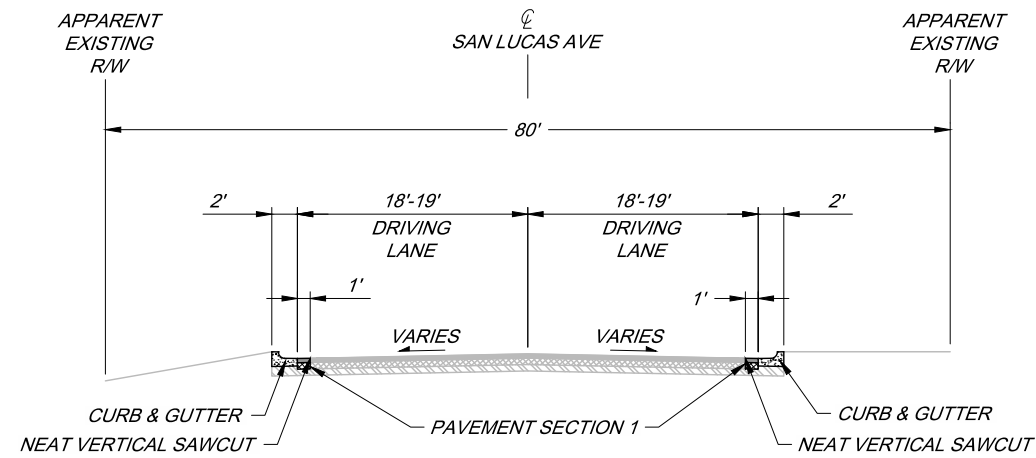

PROPOSED TYPICAL SECTION 1: SAN LUCAS AVE

STA. 10+00.00 TO STA. 10+37.48
 STA. 11+73.65 TO STA. 15+44.16

TRANSITION
 STA. 10+37.48 TO STA. 11+73.65

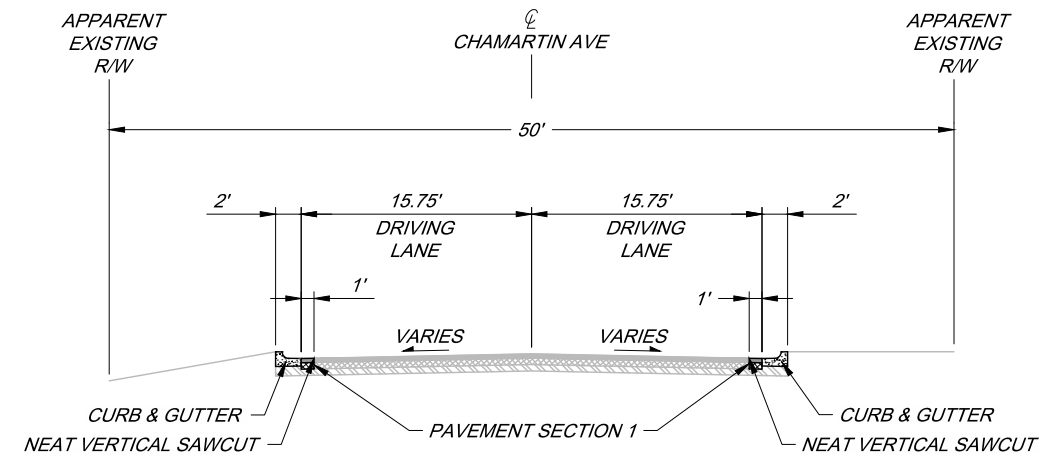

PROPOSED TYPICAL SECTION 1: CHAMARTIN AVE

STA. 20+45.87 TO STA. 20+50.87

TRANSITION
 STA. 20+18.00 TO STA. 20+45.87

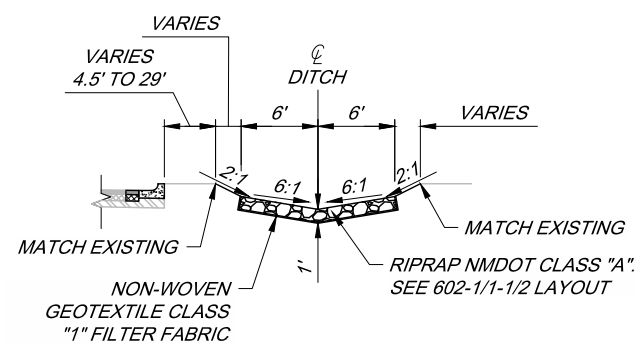

PROPOSED TYPICAL SECTION 1: DITCH

STA. 30+00.00 TO STA. 32+21.34

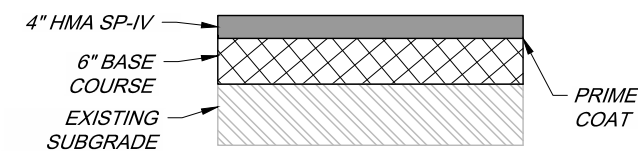

PAVEMENT SECTION 1

NO.	DESCRIPTION	DATE	BY
4			
3			
2			
1			

CN L300288
 RIO COMMUNITIES DRAINAGE IMPROVEMENTS
 PROPOSED TYPICAL SECTIONS



DATE: 28 Aug 2023 - 3:16pm USER: ANGONZALEZ



CITY OF RIO COMMUNITIES

NO.	DESCRIPTION	DATE	BY
4			
3			
2			
1			

CN L300288
RIO COMMUNITIES DRAINAGE IMPROVEMENTS
SURFACING SCHEDULE

SURFACING SCHEDULE			303000					416104				*	*	408100		
			BASE COURSE					MINOR PAVING TYPE I, HMA SP-IV				PG 76-22 ASPHALT MATERIAL	HYDRATED LIME	PRIME COAT MATERIAL		
STATION TO STATION	DESCRIPTION	LENGTH (L.F.)	AVG. WIDTH (L.F.)	AVG. DEPTH (IN.)	AREA (S.Y.)	TON	AVG. WIDTH (L.F.)	DEPTH (IN.)	AREA (S.Y.)	TON	TON	TON	AVG. WIDTH (L.F.)	AREA (S.Y.)	TON	
ALIGNMENT: SAN LUCAS AVE																
10+00.00	13+10.21	SAN LUCAS AVE	310.21	1.00	6.00	34.47	10.93	1.00	4.00	34.47	7.35	0.43	0.07	1.00	34.47	0.06
10+00.00	10+37.48	SAN LUCAS AVE	37.48	1.00	6.00	4.16	1.32	1.00	4.00	4.16	0.89	0.05	0.01	1.00	4.16	0.01
11+73.65	15+44.16	SAN LUCAS AVE	370.51	1.00	6.00	41.17	13.05	1.00	4.00	41.17	8.77	0.51	0.09	1.00	41.17	0.08
13+34.32	13+91.37	SAN LUCAS AVE	57.05	1.00	6.00	6.34	2.01	1.00	4.00	6.34	1.35	0.08	0.01	1.00	6.34	0.01
14+14.91	14+60.97	SAN LUCAS AVE	46.06	1.00	6.00	5.12	1.62	1.00	4.00	5.12	1.09	0.06	0.01	1.00	5.12	0.01
15+01.47	15+44.16	SAN LUCAS AVE	42.69	1.00	6.00	4.74	1.50	1.00	4.00	4.74	1.01	0.06	0.01	1.00	4.74	0.01
15+24.16	15+44.16	SAN LUCAS AVE	20.00	CALC	6.00	25.08	7.95	CALC	4.00	25.08	5.34	0.31	0.05	CALC	25.08	0.05
ALIGNMENT: CHAMARTIN AVE																
20+20.81	20+21.20	CHAMARTIN AVE	0.39	CALC	6.00	3.50	1.11	CALC	4.00	3.50	0.75	0.04	0.01	CALC	3.50	0.01
20+21.82	20+49.80	CHAMARTIN AVE	27.98	1.00	6.00	3.11	0.99	1.00	4.00	3.11	0.66	0.04	0.01	1.00	3.11	0.01
20+22.19	20+50.87	CHAMARTIN AVE	28.68	1.00	6.00	3.19	1.01	1.00	4.00	3.19	0.68	0.04	0.01	1.00	3.19	0.01
PROJECT TOTAL:						41.50				27.89	1.62	0.28			0.25	
PROJECT USE:						45				30	2	1			1	

- NOTES:
- AMOUNTS OF BITUMINOUS MATERIAL SHOWN ARE FOR ESTIMATING PURPOSES ONLY. CORRECT AMOUNTS WILL BE DETERMINED BY THE MATERIAL AND TESTING LABORATORY.
 - * HYDRATED LIME AND PG 76-22 QUANTITIES ARE SHOWN FOR INFORMATION OF THE CONTRACTOR ONLY.

ESTIMATED SURFACING FACTORS						
ITEM	PG 76-22 HMA SP-IV MATERIAL	TACK COAT SEC. 407	PRIME COAT SEC. 408	UNIT WEIGHT		HYDRATED LIME
	% BY WT. OF TOTAL MIX	GALLONS PER S.Y.	GAL/S.Y.	LBS. PER C.Y.	% BY WT. OF TOTAL MIX	Gallons/TON
HMA SP-IV COMPLETE	5.8% **			3836	**	1.00% **
ASPHALT MATERIAL FOR TACK COAT		0.08 *				
PRIME COAT MATERIAL			0.45 *			
BASE COURSE				3805	**	

FOR CONTRACTORS INFORMATION ONLY.

* FOR ESTIMATING PURPOSES ONLY, APPLICATION RATE WILL BE DETERMINED IN THE FIELD BY THE PROJECT MANAGER.

** FOR ESTIMATING PURPOSES ONLY, ACTUAL WEIGHTS OR PERCENT SHALL BE DETERMINED BY APPROVED MIX DESIGN.



DATE: 28 Aug 2023 - 3:16pm USER: ANGONZALEZ



CITY OF RIO COMMUNITIES

CONSTRUCTION ENGINEERING & LUMP SUM ITEMS		
NMDOT ITEM NO.	DESCRIPTION	UNIT
201000	CLEARING AND GRUBBING	LS
618000	TRAFFIC CONTROL MANAGEMENT	LS
621000	MOBILIZATION	LS
801000	CONSTRUCTION STAKING BY THE CONTRACTOR	LS
802000	POST CONSTRUCTION PLANS	LS

REMOVAL OF SURFACING							ITEM NO. 601110
STATION	TO	STATION	LENGTH (L.F.)	AVG. WIDTH (L.F.)	DEPTH (IN.)	AREA (S.Y.)	REMARKS
ALIGNMENT: SAN LUCAS AVE							
10+00.00	-	13+10.21	310.21	1.00	4	34.47	
10+00.00	-	10+37.48	37.48	1.00	4	4.16	
11+73.65	-	15+44.16	370.51	1.00	4	41.17	
13+34.32	-	13+91.37	57.05	1.00	4	6.34	
14+14.91	-	14+60.97	46.06	1.00	4	5.12	
15+01.47	-	15+44.16	42.69	1.00	4	4.74	
ALIGNMENT: CHAMARTIN AVE							
20+20.81	-	20+21.20	0.39	1.00	4	0.04	
20+21.82	-	20+49.80	27.98	1.00	4	3.11	
20+22.19	-	20+50.87	28.68	1.00	4	3.19	
						TOTAL	102.34
						USE	150.00

CONCRETE VERTICAL CURB AND GUTTER TYPE B 6" X 24"						ITEM NO. 609424
STATION	TO	STATION	LOCATION	LENGTH (L.F.)	REMARKS	
10+00.00	-	10+37.48	LT.	37.48	BUILD CURB AND GUTTER	
10+00.00	-	10+89.87	RT.	110.07	BUILD CURB AND GUTTER	
11+21.38	-	13+10.21	RT.	201.03	BUILD CURB AND GUTTER	
11+73.65	-	15+27.16	LT.	381.56	BUILD CURB AND GUTTER	
13+34.32	-	13+91.37	RT.	51.91	BUILD CURB AND GUTTER	
14+14.91	-	14+60.97	RT.	41.91	BUILD CURB AND GUTTER	
15+01.47	-	15+44.16	RT.	40.64	BUILD CURB AND GUTTER	
15+37.16	-	15+44.16	LT.	7.00	BUILD CURB AND GUTTER	
				PROJECT TOTAL	871.60	
				PROJECT USE	900	

STATION TAKEN AT LIP OF CURB AND GUTTER
CURB OPENING FOR STORM WATER INCLUDED IN THE COST FOR 609424 CONCRETE VERTICAL CURB AND GUTTER TYPE B 6" X 24". NO ADDITIONAL COST WILL BE MADE

CONCRETE VALLEY GUTTER 6" X 36"						ITEM NO. 609636
STATION	TO	STATION	LOCATION	LENGTH (L.F.)	REMARKS	
ALIGNMENT: SAN LUCAS AVE						
10+89.51	-	11+20.98	RT.	31.50	INTERSECTION OF SAN LUCAS AVE AND CHAMARTIN AVE	
				PROJECT TOTAL	31.50	
				PROJECT USE	35	

VALLEY GUTTER FILLET AREAS ARE INCLUDED IN THE COST FOR 609636 CONCRETE VALLEY GUTTER 6" X 36" AND NO ADDITIONAL COST WILL BE MADE

EARTHWORK SUMMARY					
STATION	TO	STATION	203000		REMARKS
			UNCLASSIFIED EXCAVATION	EMBANKMENT	
			C.Y.	C.Y.	
ALIGNMENT: DITCH					
30+00.00	-	32+06.34	147.11		
			SUBTOTAL:	147.11	
			PROJECT TOTALS:	147.11	
			PROJECT USE	200	

REINF. CONCRETE FOR MINOR STRUCTURES							ITEM NO. 515000
STATION	OFFSET	TO	STATION	OFFSET	AREA C.Y.	DESCRIPTION	
ALIGNMENT: SAN LUCAS AVE							
15+29.16	17.02' RT	-	15+35.82	17.02' RT	2.00		
					PROJECT TOTAL	2	
					PROJECT USE	2	

RIPRAP CLASS A					ITEM NO. 602000
STATION	TO	STATION	AREA (C.Y.)	REMARKS	
ALIGNMENT: SAN LUCAS AVE					
13+61.77	-	15+38.16	100.00		
			PROJECT TOTAL	100.00	
			PROJECT USE	100	

STRUCTURAL STEEL FOR MISCELLANEOUS STRUCTURES				ITEM NO. 541200
ALIGNMENT: SAN LUCAS AVE	LB	REMARKS		
STORM DRAIN INLET	160.00			
		PROJECT TOTAL	160	
		PROJECT USE	160	

MANHOLE TYPE C-6' DIAMETER OVER 6' TO 10' DEPTH				ITEM NO. 662022
STATION	OFFSET	EACH	DESCRIPTION	
ALIGNMENT: SAN LUCAS AVE				
15+32.49	26.10' RT	1.00		
		PROJECT TOTAL	1.00	
		PROJECT USE	1	

24" STORM DRAIN CULVERT PIPE				ITEM NO. 570437
STATION	OFFSET	L.F.	DESCRIPTION	
ALIGNMENT: SAN LUCAS AVE				
10+95.48	59.33' LT	10.00		
		PROJECT TOTAL	10.00	
		PROJECT USE	10	



NO.	DESCRIPTION	DATE	BY
4			
3			
2			
1			

RIO COMMUNITIES DRAINAGE IMPROVEMENTS
MISCELLANEOUS QUANTITIES & STRUCTURE
QUANTITIES

DATE: 28 Aug 2023 - 3:16pm USER: ANGONZALEZ



CITY OF RIO COMMUNITIES

NO.	DESCRIPTION	DATE	BY
4			
3			
2			
1			

CN L300288
 RIO COMMUNITIES DRAINAGE IMPROVEMENTS
 MISCELLANEOUS DETAILS

CURB AND GUTTER PER PLANS

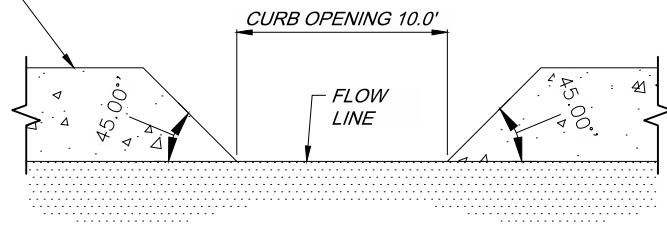

CURB OPENING DETAIL FOR STORM WATER

NOT TO SCALE

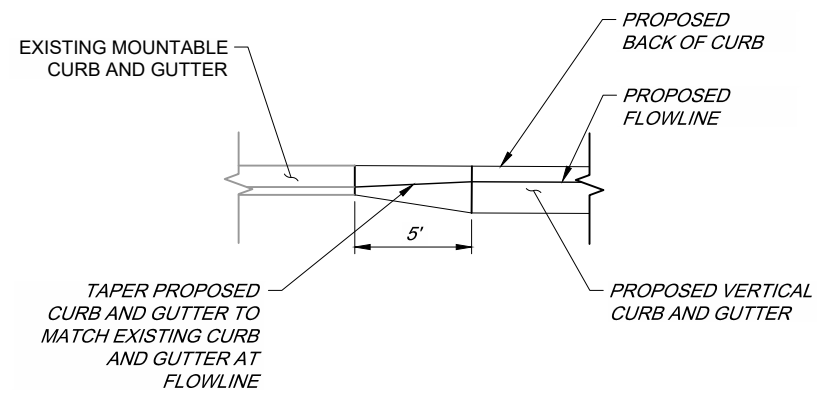

EXISTING MOUNTABLE CURB AND GUTTER TO PROPOSED CURB AND GUTTER TRANSITION

NOT TO SCALE

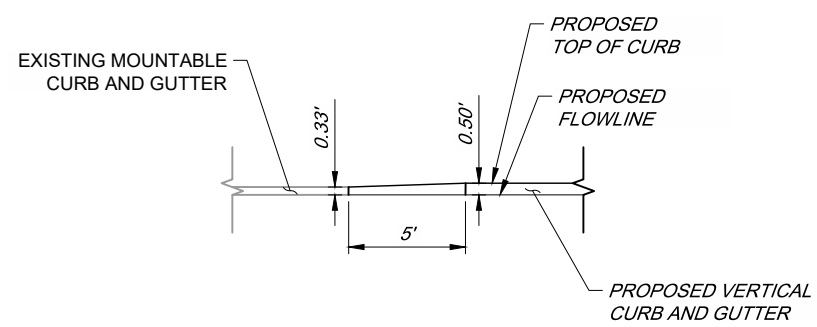

DATE: 28 Aug 2023 - 3:16pm USER: ANGONZALEZ



SAN LUCAS AVE ALIGNMENT GEOMETRY TABLE					
NUMBER	LENGTH	BEARING	TANGENT	Δ DELTA	RADIUS
L1	212.51'	N1°40'11.20"E			
C1	311.64'		197.50'	89°16'44.27"	200.00'
L2	20.00'	S89°03'04.53"E			

DITCH ALIGNMENT GEOMETRY TABLE					
NUMBER	LENGTH	BEARING	TANGENT	Δ DELTA	RADIUS
L4	2.50'	N0°56'55.47"E			
C2	12.57'		8.00'	90°00'00.00"	8.00'
C3	149.66'		77.57'	37°12'04.39"	230.50'
C4	9.27'		4.79'	35°25'20.70"	15.00'
L5	47.04'	S89°10'11.78"W			

GENERAL NOTES

- SEE SHEET 3-2 FOR SURVEY CONTROL MAP.



CITY OF RIO COMMUNITIES

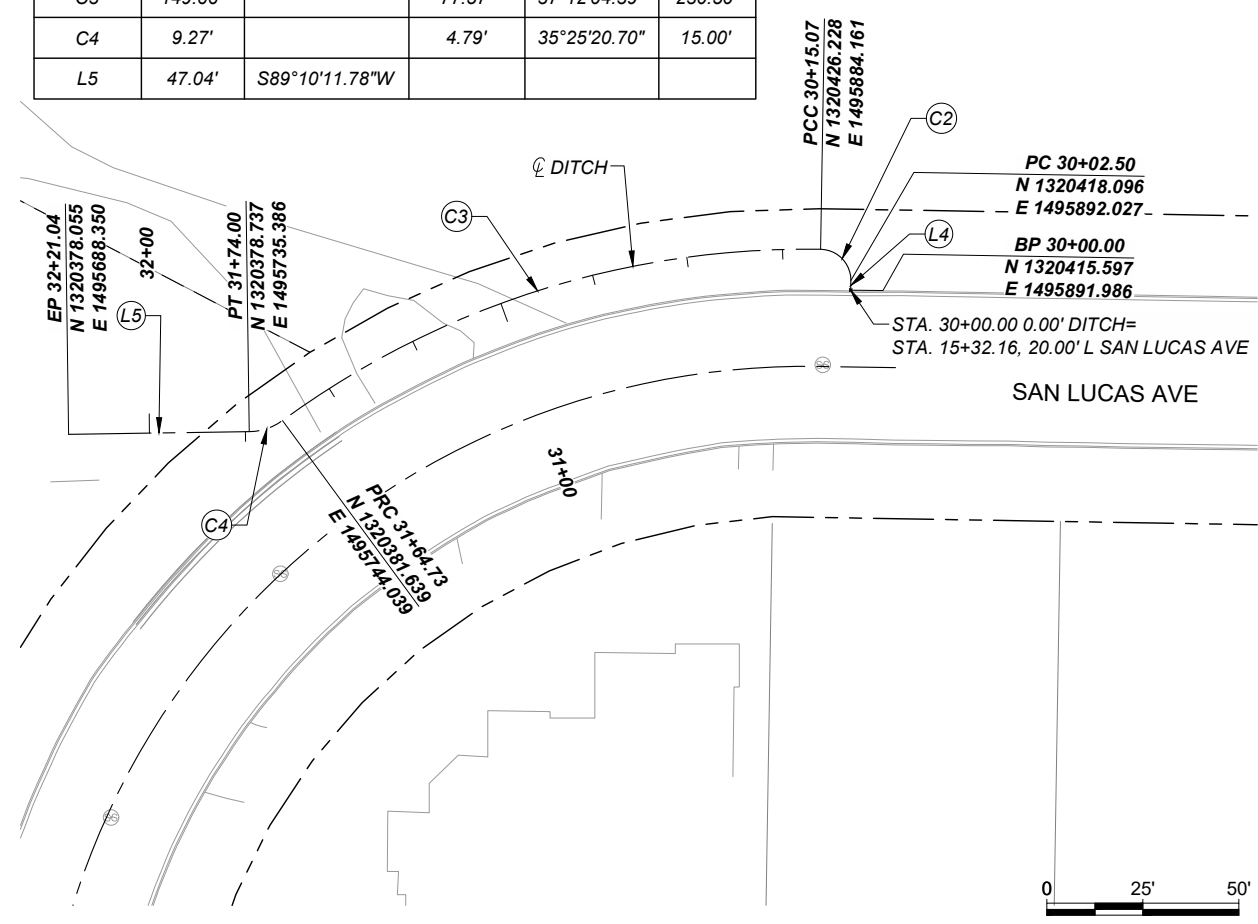
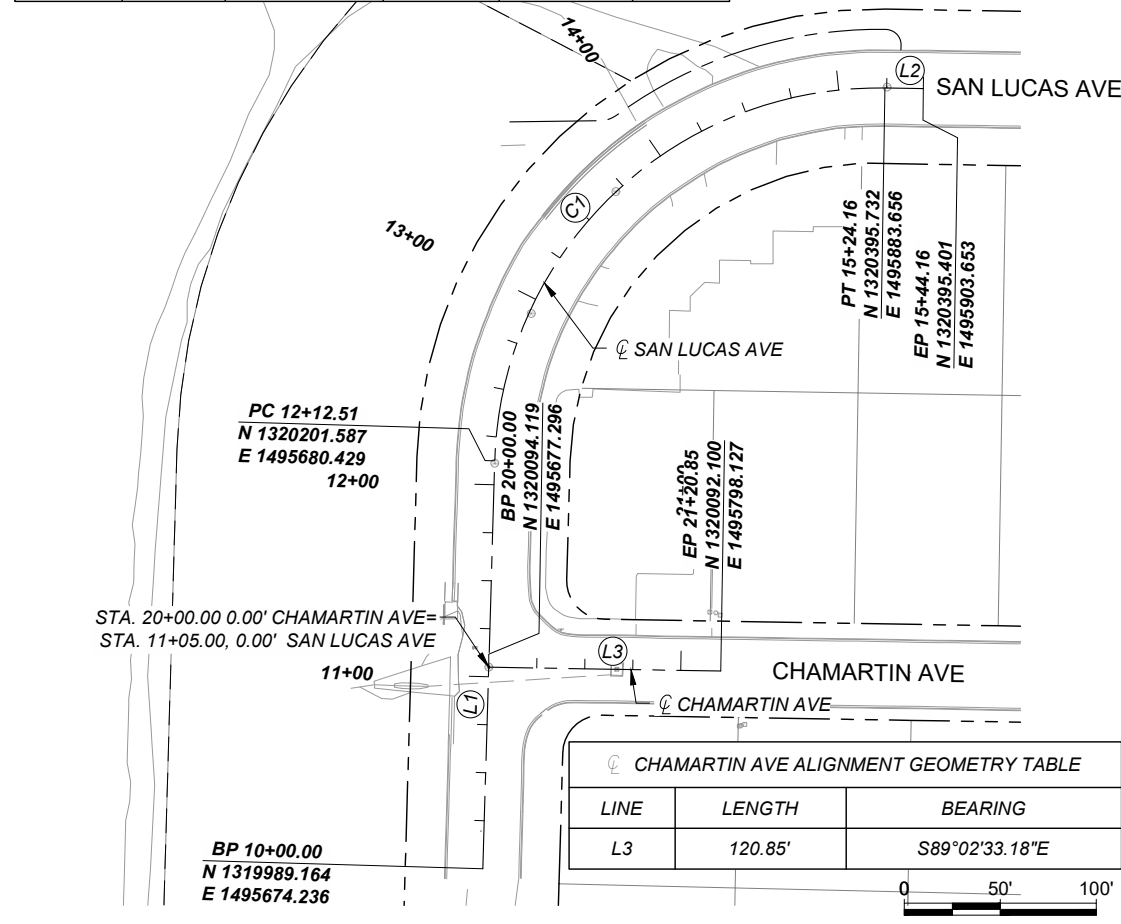

SYMBOL LEGEND:

CATV HAND HOLE	LIGHT POLE
CATV PEDESTAL	MAILBOX
CLEAN OUT	SANITARY SEWER MANHOLE
COMMUNICATION HAND HOLE	SERVICE POLE
CONTROL POINT	SIGN POST
DROP INLET	STORM DRAIN MANHOLE
ELECTRIC BOX / TRANSFORMER	TELEPHONE HAND HOLE
ELECTRIC HAND HOLE	TELEPHONE MANHOLE
ELECTRIC MANHOLE	TELEPHONE PEDESTAL
FIBER OPTIC HAND HOLE	TELEPHONE PULL BOX
FIBER OPTIC PEDESTAL	UTILITY POLE
FIRE HYDRANT	WATER FAUCET
GAS METER	WATER MANHOLE
GAS REGULATOR	WATER METER
GAS VALVE	WATER VALVE
GUY ANCHOR	
IRRIGATION CONTROL BOX	

LINE STYLE LEGEND:

FENCE LINE
EDGE OF ROAD
OVERHEAD ELECTRIC
EXISTING RIGHT OF WAY
VEGETATION
CHAIN LINK FENCE LINE
OVERHEAD UTILITIES
SANITARY SEWER
WATER FLOW



NO.	DESCRIPTION	DATE	BY
4			
3			
2			
1			

CN L300288
 RIO COMMUNITIES DRAINAGE IMPROVEMENTS
 OVERALL PROJECT SURVEY CONTROL AND
 HORIZONTAL LAYOUT

DATE: 28 Aug 2023 - 3:17pm USER: ANCONZALEZ

GENERAL NOTES:

- ALL SURVEY CONTROL POINTS WERE SET BY THE COLLIER'S ENGINEERING & DESIGN SURVEY UNIT IN OCTOBER 2022.
- THE STATE PLANE COORDINATES SHOWN HEREON ARE REFERRED TO THE NEW MEXICO COORDINATE SYSTEM - CENTRAL ZONE, NORTH AMERICAN DATUM OF 1983 AND WERE DERIVED USING VRS DIFFERENTIAL POSITIONING TECHNIQUES. VRS OBSERVATIONS WERE PERFORMED BY THE COLLIER'S ENGINEERING & DESIGN SURVEY UNIT.
- THE ELEVATIONS WERE DERIVED USING VRS ELLIPSOID HEIGHT DIFFERENCES COMBINED WITH THE NGS GEOID MODELING PROGRAM 'GEOID18'.
- THE LOCAL PROJECT GROUND COORDINATES SHOWN HEREON WERE DERIVED USING THE FOLLOWING FORMULA:
4.1. THE FINAL ADJUSTED STATE PLANE GRID COORDINATES ARE DERIVED FROM AN OPUS SOLUTION ON CP-5 AND COORDINATES ARE SCALED TO THE SURFACE USING COMBINED GRID TO THE GROUND FACTOR OF 1.000307745 AROUND AN ORIGIN OF 0,0.
- ALL DISTANCES SHOWN HEREON ARE CALCULATED GROUND DISTANCES USING THE INVERSED GRID DISTANCES AND THE PROJECT AVERAGE COMBINED GRID TO GROUND SCALE FACTOR.
- THE FIELD DATA WAS COLLECTED USING VRS NETWORK / TRIMBLE GPS RECEIVERS AND ADJUSTED UTILIZING TRIMBLE BUSINESS CENTER SOFTWARE IN OCTOBER 2022.

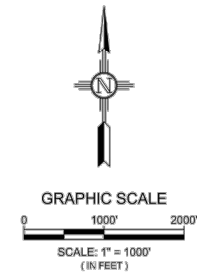
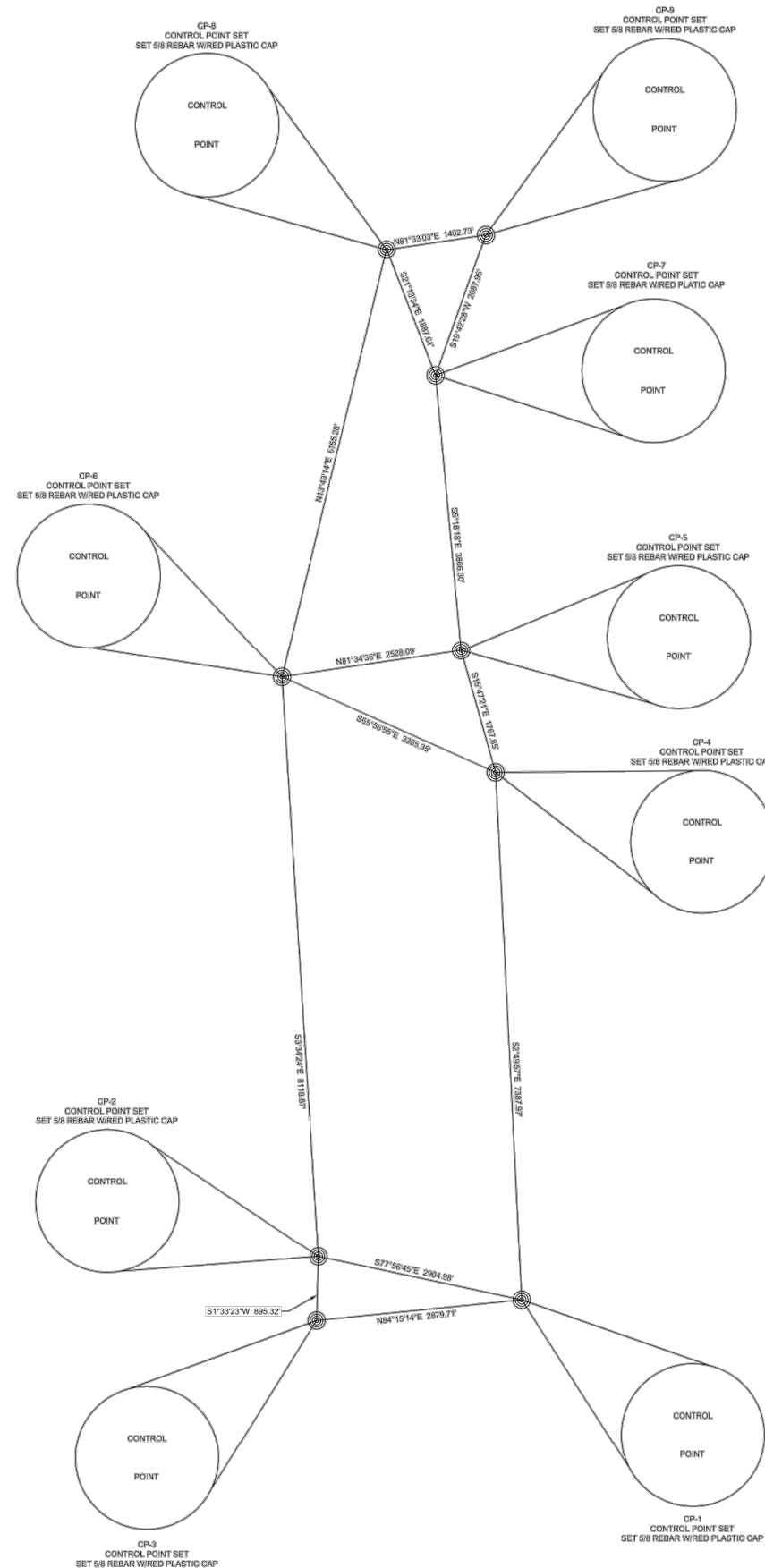

LOCAL PROJECT GROUND COORDINATES					
STATION	NORTHING [US FEET]	EASTING [US FEET]	ELEVATION	DESCRIPTION	LOCATION
CP-1	1319944.254	1498510.800	4910.70	REBAR WITH 1 1/4\"	CP-1 IS LOCATED 95' SOUTH OF LA ISLA AND LEE TREVINO BLVD INTERSECTION, 25' WEST OF LEE TREVINO BLVD CL.
CP-2	1320550.924	1496669.873	4877.01	REBAR WITH 1 1/4\"	CP-2 IS LOCATED 680' WEST OF SAN LUCAS AVE AND TRES CANTOS AVE INTERSECTION AND IS 285' NW OF SAN LUCAS CL PT. 12' WEST OF A DIRT ROAD CL.
CP-3	1319655.906	1496945.555	4896.14	REBAR WITH 1 1/4\"	CP-3 IS LOCATED 340' FROM END OF PAVEMENT OF SAN LUCAS AVE, SOUTH BOUND, 30' EAST OF A DIRT ROAD CL.
CP-4	1327323.200	1498145.769	4897.75	REBAR WITH 1 1/4\"	CP-4 IS LOCATED 50' NW FROM OF GOODMAN AVE. AND DOERING ST. INTERSECTION.
CP-5	1329024.347	1497664.683	4904.51	REBAR WITH 1 1/4\"	CP-5 IS LOCATED 40' EAST OF AVENIDA DEL FUEGO AND SOMBRERO LP INTERSECTION, 35' EAST OF SOMBRERO LP CL.
CP-6	1328654.912	1495163.860	4825.37	REBAR WITH 1 1/4\"	CP-6 IS LOCATED 210' NW OF NM 47 AND NM 304 INTERSECTION, 5' EAST OF CHAIN LINK FENCE.
CP-7	1332874.988	1497307.221	4908.75	REBAR WITH 1 1/4\"	CP-7 IS LOCATED 100' NW OF ALAME LOOP AND LA MERCED ELEMENTARY SCHOOL PARKING ENTRANCE INTERSECTION, 80' WEST OF ALAME LOOP CL.
CP-8	1334633.640	1496623.817	4874.76	REBAR WITH 1 1/4\"	CP-8 IS LOCATED 55' NW OF SHERROD BLVD AND ALAME LOOP INTERSECTION, 19' WEST OF A DIRT ROAD CL.
CP-9	1331839.748	1496011.397	4964.84	REBAR WITH 1 1/4\"	CP-9 IS LOCATED 20' NE OF CL END OF PAVEMENT OF SHERROD BLVD, 280' EAST OF SE BLDG CORNER OF CHURCH OF CHRIST RIO GRANDE.

GEODETTIC INFORMATION GEOGRAPHIC/STATE PLANE NAD83(2011) COORDINATES							
STATION	LATITUDE	LONGITUDE	NORTHING [USF]	EASTING [USF]	Zone	Geoid [USF] Separation	ELLIPSOID HEIGHT [USF]
CP-1	34°37'33.80573\"	-106°43'23.69732\"	1319944.254	1498510.800	NM C (3002)	-71.55	4838.75
CP-2	34°37'39.67186\"	-106°43'57.71777\"	1320550.924	1496669.873	NM C (3002)	-72.02	4804.99
CP-3	34°37'30.82023\"	-106°43'57.95744\"	1319655.906	1496945.555	NM C (3002)	-72.01	4824.13
CP-4	34°39'46.75856\"	-106°43'28.48044\"	1327323.200	1498145.769	NM C (3002)	-72.00	4825.75
CP-5	34°39'03.55858\"	-106°43'34.33255\"	1329024.347	1497664.683	NM C (3002)	-72.03	4832.48
CP-6	34°38'59.77849\"	-106°44'04.23733\"	1328654.912	1495163.860	NM C (3002)	-72.08	4753.29
BP-7	34°39'41.61149\"	-106°43'38.82835\"	1332874.988	1497307.221	NM C (3002)	-72.05	4836.79
CP-8	34°39'58.97936\"	-106°43'47.10764\"	1334633.640	1496623.817	NM C (3002)	-72.07	4802.69
CP-9	34°40'01.08257\"	-106°43'30.51259\"	1331839.748	1496011.397	NM C (3002)	-72.04	4832.80

LEGEND

SET 5/8\"

NO.	DESCRIPTION	DATE	BY
4			
3			
2			
1			

REVISIONS (OR CHANGE NOTICES)



I, CLAY A. WYGANT, NMPLS# 12808, DO HEREBY CERTIFY THAT THIS CONTROL SURVEY MAP AND REPORT WAS PREPARED BY ME OR UNDER MY DIRECT SUPERVISION BASED ON AN ACTUAL SURVEY ON THE GROUND AS DESCRIBED HEREIN; THAT I AM RESPONSIBLE FOR THIS SURVEY; AND THAT THE SURVEY AND REPORT MEETS THE MINIMUM STANDARDS FOR SURVEYING IN NEW MEXICO.

Clay A. Wygant
 CLAY A. WYGANT - N.M.P.S. 12808
 COLLIER'S ENGINEERING & DESIGN
 2703 BROADBENT PKWY NE SUITE B
 ALBUQUERQUE, NM 87107
 PH # (505)433-6383



RIO COMMUNITIES

RIO COMMUNITIES
CONTROL MAP
 COLLIER'S ENGINEERING & DESIGN PROJECT NO.
22002754
 VALANCIA COUNTY
 SCALE 1"=1000' SHEET 1 OF 1

CITY OF RIO COMMUNITIES

NO.	DESCRIPTION	DATE	BY
4			
3			
2			
1			

RIO COMMUNITIES DRAINAGE IMPROVEMENTS SURVEY CONTROL MAP

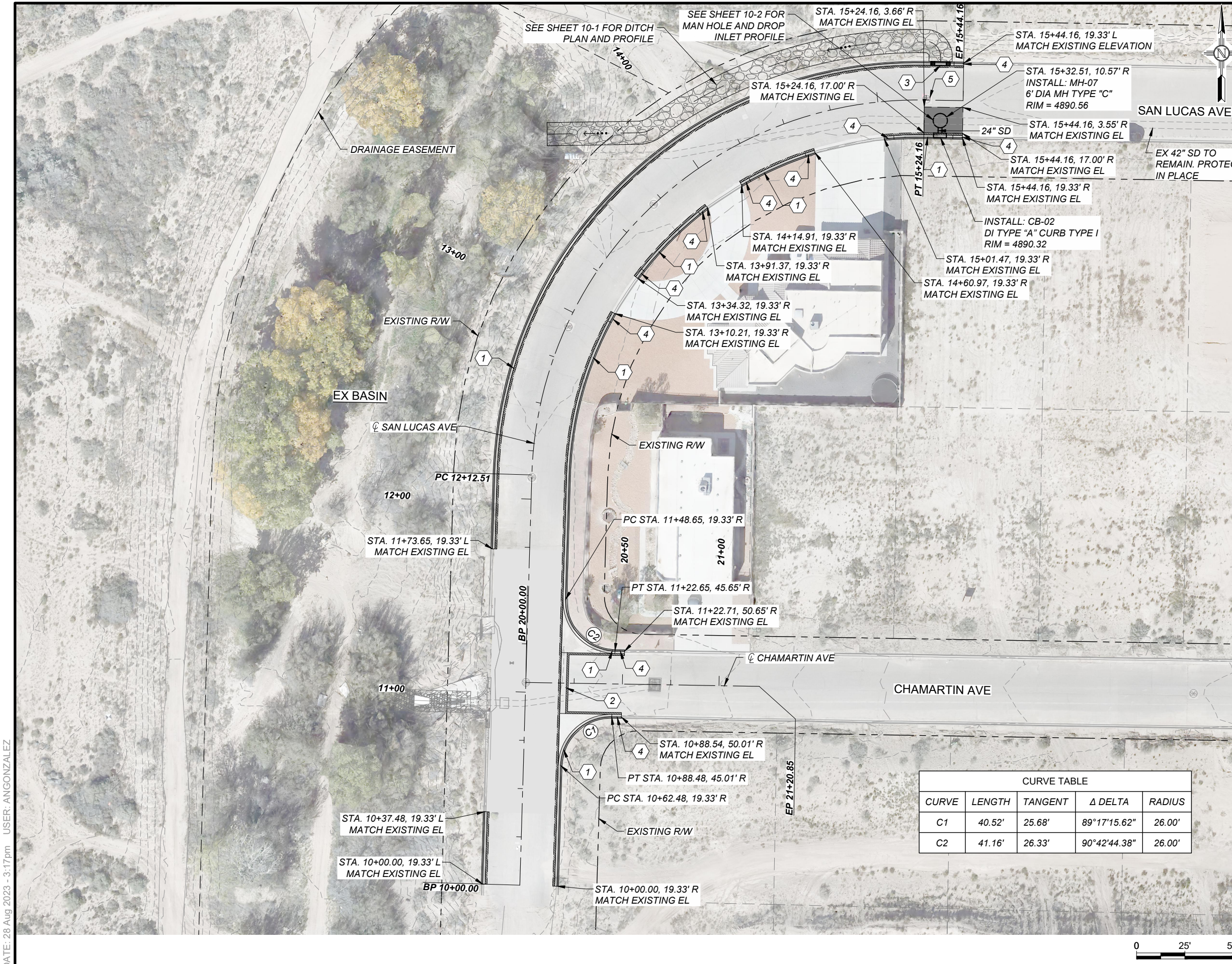

GENERAL NOTES

- NEAT VERTICAL SAWCUT EXISTING PAVEMENT AS REQUIRED FOR NEW CURB & GUTTER. MATCH EXISTING GRADE AT LIP OF NEW CURB.
- ALL UNDERGROUND UTILITIES SHOWN ON THIS PLAN ARE APPROXIMATE LOCATIONS. CONTRACTOR SHALL VERIFY LOCATION OF ALL UNDERGROUND UTILITIES BEFORE COMMENCING WORK.

KEYED NOTES

- BUILD CONCRETE VERTICAL CURB & GUTTER TYPE B 6\"X24\" PER NMDOT STD. DWG 609-01-1/1.
- BUILD CONCRETE VALLEY GUTTER 6\"X36\" PER NMDOT STD. DWG 609-01-1/1.
- CURB OPENING. SEE CURB OPENING DETAIL FOR STORM WATER ON SHEET 2-5.
- CURB TRANSITION. SEE EXISTING MOUNTABLE CURB AND GUTTER TO PROPOSED CURB AND GUTTER TRANSITION ON SHEET 2-5.
- PROTECT EXISTING SANITARY SEWER PIPE AND MANHOLE.

LEGEND

- RIPRAP SECTION PER NMDOT DWG 515-02-2/2.
- 1-FOOT PAVEMENT RECONSTRUCTION. SEE PAVEMENT SECTION 1 ON SHEET 2-2
- NEAT VERTICAL SAWCUT
- PAVEMENT RECONSTRUCTION SEE PAVEMENT SECTION 1 ON SHEET 2-2

CURVE TABLE

CURVE	LENGTH	TANGENT	Δ DELTA	RADIUS
C1	40.52'	25.68'	89°17'15.62"	26.00'
C2	41.16'	26.33'	90°42'44.38"	26.00'

ANTONIO NUNEZ-TOVAR
 NEW MEXICO
 25774
 PROFESSIONAL ENGINEER
 AUG 28, 2023

CITY OF RIO COMMUNITIES

NO.	DESCRIPTION	DATE	BY
4			
3			
2			
1			
NO.			

RIO COMMUNITIES DRAINAGE IMPROVEMENTS ROADWAY PLAN

DATE: 28 Aug 2023 - 3:17pm USER: ANGONZALEZ

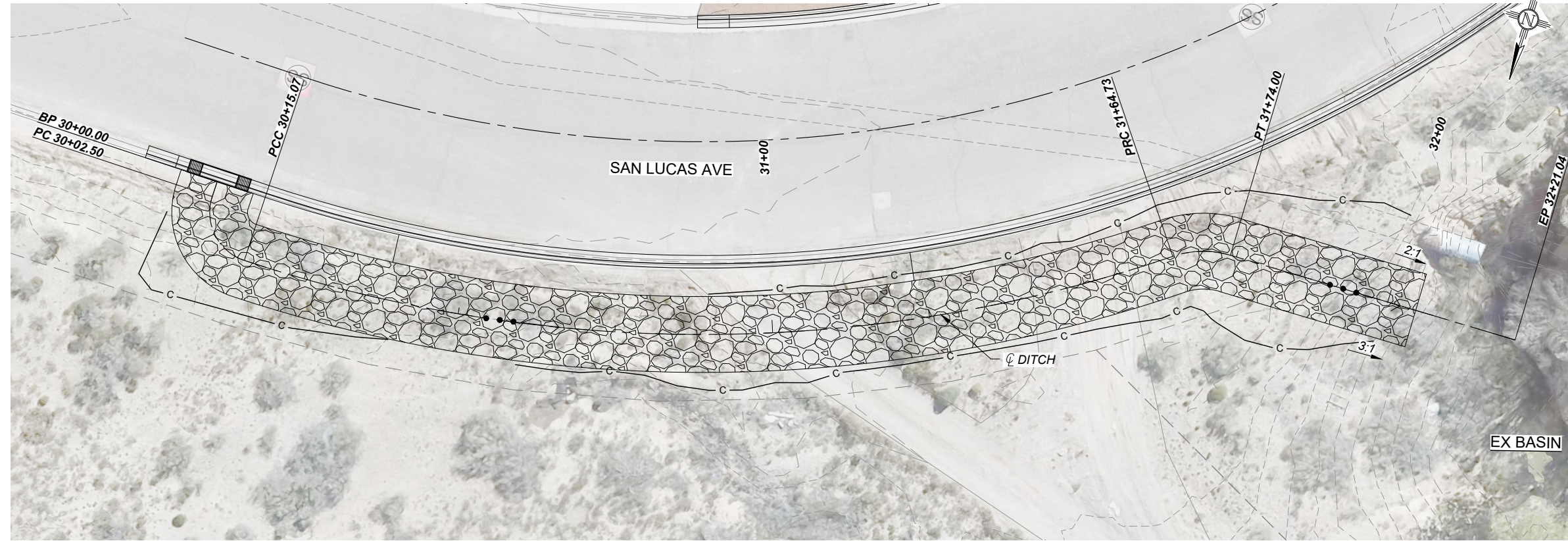

GENERAL NOTES

1. RIPRAP SHALL ADHERE TO NMDOT SECTION 602 SPECIFICATION.
2. SEE PROPOSED TYPICAL SECTION 1: DITCH ON SHEET 2-2.



CITY OF RIO COMMUNITIES

NO.	DESCRIPTION	DATE	BY
4			
3			
2			
1			

LEGEND

- RIPRAP NMDOT CLASS A
- SLOPE LIMITS

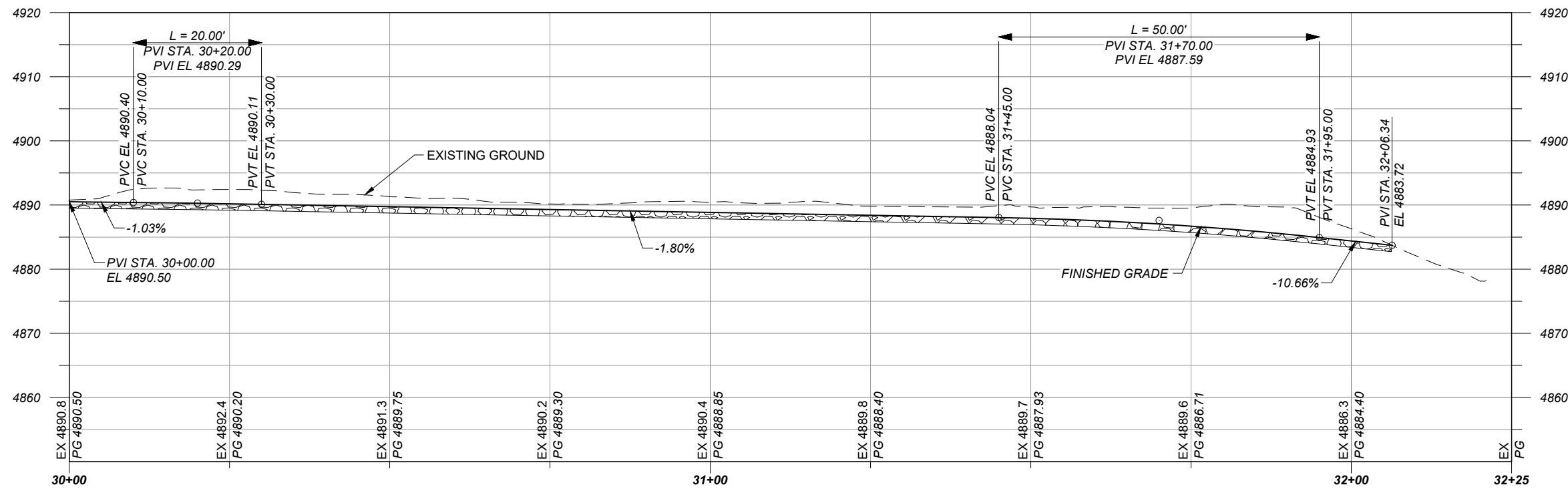

Aug 28, 2023

DATE: 28 Aug 2023 - 3:23pm USER: ANGONZALEZ

CN L300288
RIO COMMUNITIES DRAINAGE IMPROVEMENTS
DITCH PLAN AND PROFILE

GENERAL NOTES

1. TYPE "A" CURB INLETS TYPE I THRU IV - REFER TO NMDOT DETAILS 623-13-1/3 - 3/3.
2. TYPE "C" MH'S - REFER TO NMDOT DETAILS 662-01-1/1 - 3/3.
3. ALL DRAINAGE PIPE AND STRUCTURE STATIONS AND OFFSETS ARE BASED OFF PROPOSED SAN LUCAS AVE ROADWAY CENTERLINE. SEE SECTION 3 HORIZONTAL CONTROL PLAN. LOCATION OF EXISTING STORM DRAIN TO BE VERIFIED BY CONTRACTOR.
4. ALL UNDERGROUND UTILITIES SHOWN IN PLANS AND PROFILES ARE APPROXIMATE LOCATIONS BASED ON AVAILABLE INFORMATION. UNDERGROUND UTILITIES WITHOUT INFORMATION ARE ASSUMED AT A TYPICAL BURY DEPTH BELOW EXISTING GROUND. CONTRACTOR SHALL VERIFY LOCATION, SIZE, AND TYPE OF ALL EXISTING UTILITIES PRIOR TO CONSTRUCTION.
5. STATION OFFSET, AND ELEVATION FOR ALL CURB INLETS ARE AT THE FLOW LINE OF PROPOSED AND EXISTING CURB. REFER TO NMDOT STANDARD DETAILS FOR INLET STRUCTURE DEPRESSION DEPTHS AND ELEVATIONS.
6. PROTECT IN PLACE EXISTING TREES, FENCING, POWER POLES, AND OVERHEAD ELECTRIC LINES, UNLESS OTHERWISE NOTED IN PLANS.
7. MINIMUM 1.5' CLEARANCE BETWEEN PROPOSED PIPELINE AND EXISTING UTILITIES, OR USE LEANFILL ASTM D-1557.
8. SEE ESTIMATED STRUCTURES QUANTITIES IN SECTION 2 FOR PIPE MATERIAL, QUANTITIES AND BID ITEM NUMBER.



CITY OF RIO COMMUNITIES

NO.	DESCRIPTION	DATE	BY
4			
3			
2			
1			

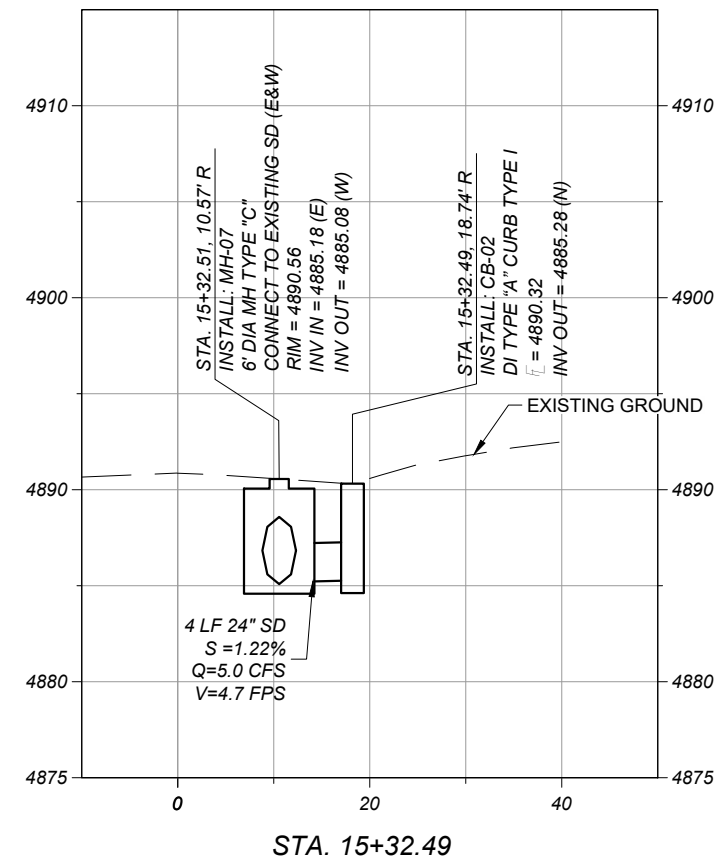

AUG 28, 2023

CN L300288
RIO COMMUNITIES DRAINAGE IMPROVEMENTS
STORM DRAIN LATERALS PROFILE

DATE: 28 Aug 2023 - 3:24pm USER: ANGONZALEZ

CITY OF RIO COMMUNITIES, NM
RESOLUTION 2023-XX

PARTICIPATION IN CAPITAL OUTLAY PROGRAM ADMINISTERED
BY NEW MEXICO DEPARTMENT OF TRANSPORTATION

WHEREAS, the City of Rio Communities and the New Mexico Department of Transportation enter into a Cooperative Agreement.

WHEREAS, the total cost of the project will be \$121,571 to be funded by the parties hereto as follows:

a. New Mexico Department of Transportation's share shall be 100% or \$121,571

and

b. *The City of Rio Communities'* proportional matching share shall be 0% or \$0.00

TOTAL PROJECT COST IS \$121,571

The City of Rio Communities shall pay all costs, which exceed the total amount of \$121,571.

Now therefore, be it resolved in official session that The City of Rio Communities determines, resolves, and orders as follows:

That the project for this Cooperative agreement is adopted and has a priority standing.

The agreement terminates on **June 30, 2027 (for Laws of 2023)** and the City of Rio Communities incorporates all the agreements, covenants, and understandings between the parties hereto concerning the subject matter hereof, and all such covenants, agreements and understandings have been merged into the written agreement.

NOW therefore, be it resolved by the City of Rio Communities to enter into Cooperative Agreement Control Number C3233370 with the New Mexico Department of Transportation for Capital Outlay (**Laws of 2023**) to *plan, design, construct and equip street lights along Horner street in Rio Communities in Valencia county* within the control of the Governing Body in City of Rio Communities, Valencia County, New Mexico.

PASSED, APPROVED AND ADOPTED THIS 25th DAY OF SEPTEMBER 2023 BY THE GOVERNING BODY OF THE CITY OF RIO COMMUNITIES, NEW MEXICO.

City of Rio Communities Governing Body

Joshua Ramsell
Mayor

Margaret R. Gutjahr
Mayor Pro-tem

Arthur Apodaca,
Councilor

Lawrence R. Gordon,
Councilor

Jimmie Winters,
Councilor

ATTEST:

Lalena Aragon,
Deputy Clerk

Contract Number: _____
Vendor Number: 00000110108
Control Number: C3233370

**STATE OF NEW MEXICO
DEPARTMENT OF TRANSPORTATION
FUND 93100 CAPITAL APPROPRIATION PROJECT**

THIS AGREEMENT is between the Department of Transportation, hereinafter called the “Department” or abbreviation such as “NMDOT”, and City of Rio Communities, hereinafter called the “Grantee”. This Agreement is effective as of the date of the last party to sign it on the signature page below.

RECITALS

WHEREAS, in the Laws of 2023, HB505, Chapter 199, Section 33, Subsection 104, the Legislature made an appropriation to the Department, funds from which the Department is making available to the Grantee pursuant to this Agreement; and

WHEREAS, the Department is granting to Grantee, and the Grantee is accepting the grant of, funds from this appropriation, in accordance with the terms and conditions of this Agreement; and

WHEREAS, pursuant to the NMSA 1978, Section 67-3-28, as amended, and State Highway Commission Policy No. 44, the Department has the authority to enter into this Grant Agreement.

AGREEMENT

NOW, THEREFORE, in consideration of the mutual covenants and obligations contained herein, the parties hereby mutually agree as follows:

ARTICLE I. PROJECT DESCRIPTION, AMOUNT OF GRANT AND REVERSION DATE

A. The project that is the subject of this Agreement is described as follows:

DFA Appropriation ID H3370 NMDOT Control Number C3233370 **\$121,571**
APPROPRIATION REVERSION DATE: 6/30/2027

Laws of 2023, Chapter 199, Section 33, Subsection 104, One Hundred Twenty One Thousand Five Hundred Seventy One Dollars and No Cents (\$121,571), to plan, design, construct and equip street lights along Horner street in Rio Communities in Valencia county. .

The Grantee’s total reimbursements shall not exceed One Hundred Twenty One Thousand Five Hundred Seventy One Dollars and No Cents \$121,571 (the “Appropriation Amount”) minus the allocation for Art in Public Places (“AIPP amount”)¹, if applicable, Zero Dollars and No Cents (\$ 0.00), which equals One

¹ The AIPP amount is “an amount of money equal to one percent or two hundred thousand dollars (\$200,000), whichever is less, of the amount of money appropriated for new construction or any major renovation exceeding one hundred thousand dollars (\$100,000).” Section 13-4A-4 NMSA 1978.

Hundred Twenty One Thousand Five Hundred Seventy One Dollars and No Cents (**\$121,571**) (the “Adjusted Appropriation Amount”).

In the event of a conflict among the Appropriation Amount, the Reversion Date, as defined herein and/or the purpose of the Project, as set forth in this Agreement, and the corresponding appropriation language in the laws cited above in this Article I(A), the language of the laws cited herein shall control.

This project is referred to throughout the remainder of this Agreement as the “Project”; the information contained in Article I(A) is referred to collectively throughout the remainder of this Agreement as the “Project Description.” Optional Attachment A sets forth additional or more stringent requirements and conditions, which are incorporated by this reference as if set forth fully herein. If Optional Attachment A imposes more stringent requirements than any requirement set forth in this Agreement, the more stringent requirements of Attachment A shall prevail, in the event of irreconcilable conflict. The Grantee shall reference the Project's number in all correspondence with and submissions to the Department concerning the Project, including, but not limited to, Requests for Payment and reports.

ARTICLE II. LIMITATION ON DEPARTMENT’S OBLIGATION TO MAKE GRANT DISBURSEMENT TO GRANTEE

A. Upon the Effective Date of this Agreement, for permissible purposes within the scope of the Project Description, the Grantee shall only be reimbursed monies for which the Department has issued and the Grantee has received a Notice of Department’s Obligation to Reimburse² Grantee (hereinafter referred to as “Notice of Obligation”). This Grant Agreement and the disbursement of any and all amounts of the above referenced Adjusted Appropriation Amount are expressly conditioned upon the following:

- (i) Irrespective of any Notice of Obligation, the Grantee’s expenditures shall be made on or before the Reversion Date and, if applicable, an Early Termination Date (i.e., the goods have been delivered and accepted or the title to the goods has been transferred to the Grantee and/or the services have been rendered for the Grantee); and
- (ii) The total amount received by the Grantee shall not exceed the lesser of: (a) the Adjusted Appropriation Amount identified in Article I(A) herein or (b) the total of all amounts stated in the Notice(s) of Obligation evidencing that the Department has received and accepted the Grantee’s Third Party Obligation(s), as defined in subparagraph iii of this Article II(A); and
- (iii) The Grantee’s expenditures were made pursuant to the State Procurement Code and execution of binding written obligations or purchase orders with third party contractors or vendors for the provision of services, including professional services, or the purchase of tangible personal property and real property for the Project, hereinafter referred to as “Third Party Obligations”; and
- (iv) The Grantee’s submittal of timely Requests for Payment in accordance with the procedures set forth in Article IX of this Agreement; and
- (v) In the event that capital assets acquired with Project funds are to be sold, leased, or licensed to or operated by a private entity, the sale, lease, license, or operating agreement:
 - a. must be approved by the applicable oversight entity (if any) in accordance with law; or
 - b. if no oversight entity is required to approve the transaction, the Department must approve the transaction as complying with law.

² “Reimburse” as used throughout this Agreement includes Department payments to the Grantee for invoices received, but not yet paid, by the Grantee from a third party contractor or vendor, if the invoices comply with the provisions of this Agreement and are a valid liability of the Grantee.

Prior to the sale, lease, license, or operating agreement being approved pursuant to Articles II(A)(v)(a) and II(A)(v)(b) herein, the Department may, in its sole and absolute discretion and unless inconsistent with State Board of Finance imposed conditions, reimburse the Grantee for necessary expenditures incurred to develop the Project sufficiently to make the sale, lease, license, or operating agreement commercially feasible, such as plan and design expenditures; and

- (vi) The Grantee's submission of documentation of all Third Party Obligations and amendments thereto (including terminations) to the Department and the Department's issuance and the Grantee's receiving of a Notice of Obligation for a particular amount in accordance with the terms of this Agreement shall be governed by the following:
- a. The Grantee shall submit to the Department one copy of all Third Party Obligations and amendments thereto (including terminations) as soon as possible after execution by the Third Party **but prior to execution by the Grantee.**
 - b. Grantee acknowledges and agrees that if it chooses to enter into a Third Party Obligation prior to receiving a Notice of Obligation that covers the expenditure, it is solely responsible for such obligations.
 - c. The Department may, in its sole and absolute discretion, issue to Grantee a Notice of Obligation for the particular amount of that Third Party Obligation that only obligates the Department to reimburse Grantee's expenditures made on or before the Reversion Date or an Early Termination Date. The current Notice of Obligation form is attached to this Agreement as Exhibit 2.
 - d. The date the Department signs the Notice of Obligation is the date that the Department's Notice of Obligation is effective. After that date, the Grantee is authorized to budget the particular amount set forth in the Notice of Obligation, execute the Third Party Obligation and request the Third Party to begin work. Payment for any work performed or goods received prior to the effective date of the Notice of Obligation is wholly and solely the obligation of the Grantee.

B. The Grantee shall implement, in all respects, the Project. The Grantee shall provide all necessary qualified personnel, material, and facilities to implement the Project. The Grantee shall finance its share (if any) of the costs of the Project, including all Project overruns.

C. Project funds shall not be used for purposes other than those specified in the Project Description.

D. Unless specifically allowed by law, Project funds cannot be used to reimburse Grantee for indirect Project costs.

ARTICLE III. NOTICE PROVISIONS AND GRANTEE AND DEPARTMENT DESIGNATED REPRESENTATIVES

Whenever written notices, including written decisions, are to be given or received, related to this Agreement, the following provisions shall apply.

The Grantee designates the person(s) listed below, or their successor, as their official representative(s) concerning all matters related to this Agreement:

Grantee: City of Rio Communities

Name: Lisa Adair
Title: Municipal Clerk
Address: 360 Rio Communities Blvd, Rio Communities, New Mexico 87002
Email: ladair@riocommunities.net
Telephone: 505-861-6803

The Grantee designates the person(s) listed below, or their successor, as their Fiscal Officer or Fiscal Agent concerning all matters related to this Agreement:

Grantee: _____
Name: _____
Title: _____
Address: _____
Email: _____
Telephone: _____

The Department designates the persons listed below, or their successors, as the Points of Contact for matters related to this Agreement.

Department: Department of Transportation District 3 Office
Name: Marguerite Johnson
Title: Capital Outlay District Coordinator
Address: P.O. Box 91750, Albuquerque, NM 87199-1750
Email: Marguerite.Johnson@dot.nm.gov
Telephone: 505-490-3502

The Grantee and the Department agree that either party shall send all notices, including written decisions, related to this Agreement to the above named persons by email or regular mail. In the case of mailings, notices shall be deemed to have been given and received upon the date of the receiving party’s actual receipt or five calendar days after mailing, whichever shall first occur. In the case of email transmissions, the notice shall be deemed to have been given and received on the date reflected on the delivery receipt of email.

ARTICLE IV. REVERSION DATE, TERM, DEADLINE TO EXPEND FUNDS

A. As referenced in Article I(A), the applicable law establishes a date by which Project funds must be expended by Grantee, which is referred to throughout the remainder of this Agreement as the “Reversion Date.” Upon being duly executed by both parties, this Agreement shall be effective as of the date of execution by the Department. It shall terminate on 6/30/2027 the Reversion Date unless Terminated Before Reversion Date (“Early Termination”) pursuant to Article V herein.

B. The Project’s funds must be expended on or before the Reversion Date and, if applicable, Early Termination Date of this Agreement. For purposes of this Agreement, it is not sufficient for the Grantee to encumber the Project funds on its books on or before the Project's Reversion Date or Early Termination Date. Funds are expended and an expenditure has occurred as of the date that a particular quantity of goods are delivered to and received by the Grantee or title to the goods is transferred to the Grantee and/or as of the date

particular services are rendered for the Grantee. Funds are *not* expended and an expenditure has *not* occurred as of the date they are encumbered by the Grantee pursuant to a contract or purchase order with a third party.

ARTICLE V. EARLY TERMINATION

A. Early Termination Before Reversion Date Due to Completion of the Project or Complete Expenditure of the Adjusted Appropriation or Violation of this Agreement

Early Termination includes:

- (i) Termination due to completion of the Project before the Reversion Date; or
- (ii) Termination due to complete expenditure of the Adjusted Appropriation Amount before the Reversion Date; or
- (iii) Termination for violation of the terms of this Agreement; or
- (iv) Termination for suspected mishandling of public funds, including but not limited to, fraud, waste, abuse, and conflicts of interest.

Either the Department or the Grantee may early terminate this Agreement prior to the Reversion Date by providing the other party with a minimum of fifteen (15) days' advance, written notice of early termination. Grantee hereby waives any rights to assert an impairment of contract claim against the Department or the State of New Mexico in the event of Early Termination of this Agreement by the Department pursuant to Article V(A).

B. Early Termination Before Reversion Date Due to Non-appropriation

The terms of this Agreement are expressly made contingent upon sufficient appropriations and authorization being made by the Legislature of New Mexico for the performance of this Agreement. Throughout this Agreement the term "non-appropriate" or "non-appropriation" includes the following actions by the New Mexico Legislature: deauthorization, reauthorization or revocation of a prior authorization. The Legislature may choose to non-appropriate the Appropriation referred to in Article I and, if that occurs, the Department shall early terminate this Agreement for non-appropriation by giving the Grantee written notice of such termination, and such termination shall be effective as of the effective date of the law making the non-appropriation. The Department's decision as to whether sufficient appropriations or authorizations are available shall be accepted by the Grantee and shall be final. Grantee hereby waives any rights to assert an impairment of contract claim against the Department or the State of New Mexico in the event of Early Termination of this Agreement by the Department pursuant to Article V(B).

C. Limitation on Department's Obligation to Make Grant Disbursements to Grantee in the Event of Early Termination

In the event of Early Termination of this Agreement by either party, the Department's sole and absolute obligation to reimburse the Grantee is expressly conditioned upon the limitations set forth Article II.

ARTICLE VI. SUSPENSION OF NEW OR FURTHER OBLIGATIONS

A. The Department may choose, in its sole and absolute discretion, to provide written notice to the Grantee to suspend entering into new and further obligations. Upon the receipt of such written notice by the Grantee:

- (i) The Grantee shall immediately suspend entering into new or further written obligations with third parties; and

- (ii) The Department will suspend the issuance of any new or further Notice of Obligation under this Agreement; and
- (iii) The Department may direct the Grantee to implement a corrective action plan in accordance with Article VI(D) herein.

B. In the event of Suspension of this Agreement, the Department's sole and absolute obligation to reimburse the Grantee is expressly conditioned upon the limitations set forth in Article II herein.

C. A suspension of new or further obligations under this Agreement shall remain in effect unless or until the date the Grantee receives written notice given by the Department informing the Grantee that the Suspension has been lifted or that the Agreement has been Early Terminated in accordance with Article V herein. If the Suspension is lifted, the Department will consider further requests for Notice of Obligation.

D. Corrective Action Plan in the Event of Suspension

In the event that the Department chooses, in its sole and absolute discretion to direct the Grantee to suspend entering into new or further written obligations with third parties pursuant to Article VI(A), the Department may, but is not obligated to, require the Grantee to develop and implement a written corrective action plan to remedy the grounds for the Suspension. Such corrective action plan must be approved by the Department and be signed by the Grantee. Failure to sign a corrective action plan or meet the terms and deadlines set forth in the signed corrective action plan, is hereby deemed a violation of the terms of this Agreement for purposes of Early Termination, Article V(A)(iii). The corrective action plan is in addition to, and not in lieu of, any other equitable or legal remedy, including but not limited to Early Termination.

ARTICLE VII. AMENDMENT

This Agreement shall not be altered, changed, or amended except by instrument in writing duly executed by both the parties hereto.

ARTICLE VIII. REPORTS

A. Database Reporting

The Grantee shall report quarterly Project activity by entering such Project information as the Department and the Department of Finance and Administration may require, such information entered directly into a database maintained by the Department of Finance and Administration (Budget & Formulation Management System). Additionally, the Grantee shall certify on the Request for Payment form (Exhibit 1) that updates have been maintained and are current in the database. The Grantee hereby acknowledges that failure to perform and/or certify updates into the database will delay or potentially jeopardize the reimbursement of funds. The Department shall give Grantee a minimum of thirty (30) days' advance written notice of any changes to the information the Grantee is required to report.

Quarterly reports shall be due on the last day of the month that is 30 days prior to the end of the quarter following execution of this Agreement by the Department and ending during the quarter of the submission of the final request for reimbursement for the Project, or the following quarter.

B. Requests for Additional Information/Project Inspection

During the term of this Agreement and during the period of time during which the Grantee must maintain records pursuant to Article VIII, the Department may:

- (i) request such additional information regarding the Project as it deems necessary; and
- (ii) conduct, at reasonable times and upon reasonable notice, onsite inspections of the Project.

Grantee shall respond to such requests for additional information within a reasonable period of time, as established by the Department.

ARTICLE IX. REQUEST FOR PAYMENT PROCEDURES AND DEADLINES

A. The Grantee shall request payment by submitting a Request for Payment, in the form attached hereto as Exhibit 1. Payment requests are subject to the following procedures:

- (i) The Grantee must submit a Request for Payment; and
- (ii) Each Request for Payment must contain proof of payment by the Grantee or liabilities incurred by the Grantee showing that the expenditures are valid or are liabilities incurred by the Grantee in the form of actual unpaid invoices received by the Grantee for services rendered by a third party or items of tangible personal property received by the Grantee for the implementation of the Project; provided, however, that the Grantee may be reimbursed for unpaid liabilities only if the Department, in its sole and absolute discretion, agrees to do so and in accordance with any special conditions imposed by the Department.
- (iii) In cases where the Grantee is submitting a Request for Payment to the Department based upon invoices received, but not yet paid, by the Grantee from a third party contractor or vendor, if the invoices comply with the provisions of this Agreement and are a valid liability of the Grantee, the Grantee shall make payment to those contractors or vendors within five (5) business days from the date of receiving reimbursement from the Department or such shorter period of time as the Department may prescribe in writing. The Grantee is required to certify to the Department proof of payment to the third party contractor or vendor within ten (10) business days from the date of receiving reimbursement from the Department.

B. The Grantee must obligate 5% of the Adjusted Appropriation Amount within six months of acceptance of the grant agreement and must have expended no less than 85% of the Adjusted Appropriation Amount six months prior to the reversion date.

C. **Deadlines**

Requests for Payments shall be submitted by Grantee to the Department on the earlier of:

- (i) Immediately as they are received by the Grantee but at a minimum thirty (30) days from when the expenditure was incurred or liability of the Grantee was approved as evidenced by an unpaid invoice received by the Grantee from a third party contractor or vendor; or
- (ii) Twenty (20) days from date of Early Termination; or
- (iii) Twenty (20) days from the Reversion Date.

D. The Grantee's failure to abide by the requirements set forth in Article II and Article IX herein will result in the denial of its Request for Payment or will delay the processing of Requests for Payment. The Department has the right to reject a payment request for the Project unless and until it is satisfied that the expenditures in the Request for Payment are for permissible purposes within the meaning of the Project Description and that the expenditures and the Grantee are otherwise in compliance with this Agreement, including but not limited to, compliance with the reporting requirements and the requirements set forth in

Article II herein to provide Third Party Obligations and the Deadlines set forth in Article IX herein. The Department's ability to reject any Request for Payment is in addition to, and not in lieu of, any other legal or equitable remedy available to the Department due to Grantee's violation of this Agreement.

ARTICLE X. PROJECT CONDITIONS AND RESTRICTIONS; REPRESENTATIONS AND WARRANTIES

- A. The following general conditions and restrictions are applicable to the Project:
- (i) The Project's funds must be spent in accordance with all applicable state laws, regulations, policies, and guidelines, including, but not limited to, the State Procurement Code (or local procurement ordinance, where applicable).
 - (ii) The Project must be implemented in accordance with the New Mexico Public Works Minimum Wage Act, Section 13-4-10 through 13-4-17 NMSA 1978, as applicable. Every contract or project in excess of sixty thousand dollars (\$60,000) that the Grantee is a party to for construction, alteration, demolition or repair or any combination of these, including painting and decorating, of public buildings, public works or public roads and that requires or involves the employment of mechanics, laborers or both shall contain a provision stating the minimum wages and fringe benefits to be paid to various classes of laborers and mechanics, shall be based upon the wages and benefits that will be determined by the New Mexico Department of Workforce Solutions to be prevailing for the corresponding classes of laborers and mechanics employed on contract work of a similar nature in the locality. Further, every contract or project shall contain a stipulation that the contractor, subcontractor, employer or a person acting as a contractor shall pay all mechanics and laborers employed on the site of the project, unconditionally and not less often than once a week and without subsequent unlawful deduction or rebate on any account, the full amounts accrued at time of payment computed at wage rates and fringe benefit rates not less than those determined pursuant to Section 13-4-11 (B) NMSA 1978 to be the prevailing wage rates and prevailing fringe benefit rates issued for the project.
 - (iii) The Project may only benefit private entities in accordance with applicable law, including, but not limited to, Article IX, Section 14 of the Constitution of the State of New Mexico, the "Anti-Donation Clause."
 - (iv) The Grantee shall not for a period of 10 years from the date of this agreement convert any property acquired, built, renovated, repaired, designed or developed with the Project's funds to uses other than those specified in the Project Description without the Department's and the Board of Finance's express, advance, written approval, which may include a requirement to reimburse the State for the cost of the project, transfer proceeds from the disposition of property to the State, or otherwise provide consideration to the State.
 - (v) The Grantee shall comply with all federal and state laws, rules and regulations pertaining to equal employment opportunity. In accordance with all such laws, rules and regulations the Grantee agrees to assure that no person shall, on the grounds of race, color, national origin, sex, sexual preference, age or handicap, be excluded from employment with Grantee, be excluded from participation in the Project, be denied benefits or otherwise be subject to discrimination under, any activity performed under this Agreement. If Grantee is found to be not in compliance with these requirements during the life of this Agreement, Grantee agrees to take appropriate steps to correct any deficiencies. The Grantee's failure to implement such appropriate steps within a reasonable time constitutes grounds for terminating this Agreement.

- B. The Grantee hereby represents and warrants the following:
- (i) The Grantee has the legal authority to receive and expend the Project's funds.
 - (ii) This Agreement has been duly authorized by the Grantee, the person executing this Agreement has authority to do so, and, once executed by the Grantee, this Agreement shall constitute a binding obligation of the Grantee, enforceable according to its terms.
 - (iii) This Agreement and the Grantee's obligations hereunder do not conflict with any law or ordinance or resolution applicable to the Grantee, the Grantee's charter (if applicable), or any judgment or decree to which the Grantee is subject.
 - (iv) The Grantee has independently confirmed that the Project Description, including, but not limited to, the amount and Reversion Date, is consistent with the underlying appropriation in law.
 - (v) The Grantee's governing body has duly adopted or passed as an official act a resolution, motion, or similar action authorizing the person identified as the official representative of the Grantee to sign the Agreement and to sign Requests for Payment.
 - (vi) The Grantee shall abide by New Mexico laws regarding conflicts of interest, governmental conduct and whistleblower protection. The Grantee specifically agrees that no officer or employee of the local jurisdiction or its designees or agents, no member of the governing body, and no other public official of the locality who exercises any function or responsibility with respect to this Grant, during their tenure or for one year thereafter, shall have any interest, direct or indirect, in any contract or subcontract, or the proceeds thereof, for work to be performed or goods to be received, pursuant to this Grant. Further, Grantee shall require all of its contractors to incorporate in all subcontracts the language set forth in this paragraph prohibiting conflicts of interest.
 - (vii) No funds have been paid or will be paid, by or on behalf of the Grantee, to any person for influencing or attempting to influence an officer or employee of this or any agency or body in connection with the awarding of any Third Party Obligation and that the Grantee shall require certifying language prohibiting lobbying to be included in the award documents for all subawards, including subcontracts, loans and cooperative agreements. All subrecipients shall be required to certify accordingly.

ARTICLE XI. STRICT ACCOUNTABILITY OF RECEIPTS AND DISBURSEMENTS; PROJECT RECORDS

A. The Grantee shall be strictly accountable for receipts and disbursements relating to the Project's funds. The Grantee shall follow generally accepted accounting principles, and, if feasible, maintain a separate bank account or fund with a separate organizational code, for the funds to assure separate budgeting and accounting of the funds.

B. For a period of six (6) years following the Project's completion, the Grantee shall maintain all Project related records, including, but not limited to, all financial records, requests for proposals, invitations to bid, selection and award criteria, contracts and subcontracts, advertisements, minutes of pertinent meetings, as well as records sufficient to fully account for the amount and disposition of the total funds from all sources budgeted for the Project, the purpose for which such funds were used, and such other records as the Department shall prescribe.

C. The Grantee shall make all Project records available to the Department, the Department of Finance and Administration, and the New Mexico State Auditor upon request. With respect to the funds that are the

subject of this Agreement, if the State Auditor or the Department of Finance and Administration finds that any or all of these funds were improperly expended, the Grantee may be required to reimburse to the State of New Mexico, to the originating fund, any and all amounts found to be improperly expended.

ARTICLE XII. IMPROPERLY REIMBURSED FUNDS

If the Department determines that part or all of the Appropriation Amount was improperly reimbursed to Grantee, including but not limited to, Project funds reimbursed to Grantee based upon fraud, mismanagement, misrepresentation, misuse, violation of law by the Grantee, or violation of this Agreement, the Grantee shall return such funds to the Department for disposition in accordance with law.

ARTICLE XIII. LIABILITY

Neither party shall be responsible for liability incurred as a result of the other party's acts or omissions in connection with this Agreement. Any liability incurred in connection with this Agreement is subject to immunities and limitations of the New Mexico Tort Claims Act.

ARTICLE XIV. SCOPE OF AGREEMENT

This Agreement constitutes the entire and exclusive agreement between the Grantee and Department concerning the subject matter hereof. The Agreement supersedes any and all prior or contemporaneous agreements, understandings, discussions, communications, and representations, written or verbal.

ARTICLE XV. REQUIRED NON-APPROPRIATIONS CLAUSE IN CONTRACTS FUNDED IN WHOLE OR PART BY FUNDS MADE AVAILABLE UNDER THIS AGREEMENT

The Grantee acknowledges, warrants, and agrees that Grantee shall include a “non-appropriations” clause in all contracts between it and other parties that are (i) funded in whole or part by funds made available under this Agreement and (ii) entered into after the effective date of this Agreement that states:

“The terms of this Agreement are contingent upon sufficient appropriations and authorization being made by the Legislature of New Mexico for the performance of this Agreement. If sufficient appropriations and authorization are not made by the Legislature, the City of Rio Communities may immediately terminate this Agreement by giving Contractor written notice of such termination. The City of Rio Communities’s decision as to whether sufficient appropriations are available shall be accepted by the Contractor and shall be final. Contractor hereby waives any rights to assert an impairment of contract claim against the City of Rio Communities or the Department of Transportation or the State of New Mexico in the event of immediate or Early Termination of this Agreement by the City of Rio Communities or the Department”

ARTICLE XVI. REQUIRED TERMINATION CLAUSE IN CONTRACTS FUNDED IN WHOLE OR PART BY FUNDS MADE AVAILABLE UNDER THIS AGREEMENT

Grantee acknowledges, warrants, and agrees that Grantee shall include the following termination clause in all contracts that are (i) funded in whole or part by funds made available under this Agreement and (ii) entered into after the effective date of this Agreement:

“This contract is funded in whole or in part by funds made available under a Department of Transportation Grant Agreement. Should the Department of Transportation early terminate the grant agreement, the City of Rio Communities may early terminate this contract by providing Contractor written notice of such termination. In the event of termination pursuant to this paragraph, the City of Rio Communities only liability shall be to pay Contractor for acceptable goods delivered and services rendered before the termination date.”

Grantee hereby waives any rights to assert an impairment of contract claim against the Department or the State of New Mexico in the event of Early Termination of this Agreement by the Department.

XVII. COMPLIANCE WITH UNIFORM FUNDING CRITERIA.

A. Throughout the term of this Agreement, Grantee shall:

1. submit all reports of annual audits and agreed upon procedures required by Section 12-6-3(A)-(B) NMSA 1978 by the due dates established in 2.2.2 NMAC, reports of which must be a public record pursuant to Section 12-6-5(A) NMSA 1978 within forty-five days of delivery to the State Auditor;
2. have a duly adopted budget for the current fiscal year approved by its budgetary oversight agency (if any);
3. timely submit all required financial reports to its budgetary oversight agency (if any); and
4. have adequate accounting methods and procedures to expend grant funds in accordance with applicable law and account for and safeguard grant funds and assets acquired by grant funds.

B. In the event Grantee fails to comply with the requirements of Paragraph A of this Article XVII, the Department may take one or more of the following actions:

1. suspend new or further obligations pursuant to Article VI(A) of this Agreement;
2. require the Grantee to develop and implement a written corrective action plan pursuant to Article VI(D) of this Agreement to remedy the non-compliance;
3. impose special grant conditions to address the non-compliance by giving the Grantee notice of such special conditions in accordance with Article III of this Agreement; the special conditions shall be binding and effective on the date that notice is deemed to have been given pursuant to Article III; or
4. terminate this Agreement pursuant to Article V(A) of this Agreement.

ARTICLE XVIII. SEVERANCE TAX BOND AND GENERAL OBLIGATION BOND PROJECT CLAUSES

A. Grantee acknowledges and agrees that the underlying appropriation for the Project is a severance tax bond or general obligation bond appropriation, and that the associated bond proceeds are administered by the New Mexico State Board of Finance (SBOF), an entity separate and distinct from the Department. Grantee acknowledges and agrees that (i) it is Grantee’s sole and absolute responsibility to determine through SBOF staff what (if any) conditions are currently imposed on the Project; (ii) the Department’s failure to inform Grantee of a SBOF imposed condition does not affect the validity or enforceability of the condition; (iii) the SBOF may in the future impose further or different conditions upon the Project; (iv) all SBOF conditions are effective without amendment of this Agreement; (v) all applicable SBOF conditions must be satisfied before the SBOF will release to the Department funds subject to the condition(s); and (vi) the Department’s obligation to reimburse Grantee from the Project is contingent upon the then current SBOF conditions being satisfied.

B. Grantee acknowledges and agrees that the SBOF may in its sole and absolute discretion remove a project’s assigned bond proceeds if the project doesn’t proceed sufficiently. Entities must comply with the

requirement to encumber five percent (5%) of Project funds within six months of bond issuance as certified by the grantee in the Bond Questionnaire and Certification documents submitted to the SBOF. Failure to comply may result in the bond proceeds reassignment to a new ready project. If this should occur this grant agreement will be suspended until the entity has demonstrated readiness as determined by the SBOF and the Department.

C. Grantee acknowledges and agrees that this Agreement is subject to the SBOF's Bond Project Disbursements rule, NMAC 2.61.6, as may be amended or re-codified. The rule provides definitions and interpretations of grant language for the purpose of determining whether a particular activity is allowable under the authorizing language of the agreement.

[THIS SPACE LEFT BLANK INTENTIONALLY]

IN WITNESS WHEREOF, the parties have duly executed this Agreement as of the date of execution by the Department.

GRANTEE

Signature of Official with Authority to Bind Grantee

Entity Name

By: _____
(Type or Print Name)

Its: _____
(Type or Print Title)

Date

DEPARTMENT OF TRANSPORTATION

By:

Its: Cabinet Secretary or Designee

Date

REVIEWED AND APPROVED AS TO FORM AND LEGAL SUFFICIENCY BY THE DEPARTMENT'S OFFICE OF GENERAL COUNSEL

DocuSigned by:

Christine Schwamberger

59367CA1DB434D1...

By: Aaron Frankland or Designee

Its: Deputy General Counsel

9/6/2023

Date

**STATE OF NEW MEXICO
CAPITAL GRANT PROJECT
Request for Payment Form
Exhibit 1**

I. Grantee Information				II. Payment Computation			
(Make sure information is complete & accurate)							
A.	Grantee:			A.	Payment Request No.		
B.	Address:			B.	Grant Amount:		
(Complete Mailing, including Suite, if applicable)				C.	AIPP Amount (If Applicable):		
				D.	Funds Requested to Date:		
				E.	Amount Requested this Payment:		
				F.	Reversion Amount (If Applicable):		
	City	State	Zip	G.	Grant Balance:		
C.	Phone No:			H.	<input type="checkbox"/> GF <input type="checkbox"/> GOB <input type="checkbox"/> STB (attach wire if first draw)		
D.	Grant No:			I.	<input type="checkbox"/> Final Request for Payment (if Applicable)		
E.	Project Title:						
F.	Grant Expiration Date:						
III. Fiscal Year :							
(The State of NM Fiscal Year is July 1, 20XX through June 30, 20XX of the following year)							
IV.	Reporting Certification: I hereby certify to the best of my know ledge and belief, that database reporting is up to date; to include the accuracy of expenditures and grant balance, project status, project phase, achievements and milestones; and in compliance with Article VIII of the Capital Outlay Grant Agreement.						
<input type="checkbox"/>							
V.	Compliance Certification: Under penalty of law , I hereby certify to the best of my know ledge and belief, the above information is correct; expenditures are properly documented, and are valid expenditures or actual receipts; and that the grant activity is in full compliance w ith Article IX, Sec. 14 of the New Mexico Constitution know n as the "anti donation" clause.						
<input type="checkbox"/>							
Grantee Fiscal Officer or Fiscal Agent (if applicable)				Grantee Representative			
Printed Name				Printed Name			
Date:				Date:			
(State Agency Use Only)							
Vendor Code:		Fund No.:		Loc No.:			
I certify that the State Agency financial and vendor file information agree with the above submitted information.							
Division Fiscal Officer				Division Project Manager			
Date				Date			

**NOTICE OF OBLIGATION TO REIMBURSE GRANTEE
EXHIBIT 2**

Notice of Obligation to Reimburse Grantee [# 1]

DATE: [_____]

TO: Department Representative: [_____,_____]

FROM: Grantee: [_____]

Grantee Official Representative: [_____]

SUBJECT: Notice of Obligation to Reimburse Grantee

Grant Number: [_____]

Grant Termination Date: [_____]

As the designated representative of the Department for Grant Agreement number [_____]
entered into between Grantee and the Department, I certify that the Grantee has submitted to the Department the
following third party obligation executed, in writing, by the third party's authorized representative:

Vendor or Contractor: [_____]

Third Party Obligation Amount: [_____]

Vendor or Contractor: [_____]

Third Party Obligation Amount: [_____]

Vendor or Contractor: [_____]

Third Party Obligation Amount: [_____]

I certify that the State is issuing this Notice of Obligation to Reimburse Grantee for permissible purposes within
the scope of the project description, subject to all the terms and conditions of the above referenced Grant
Agreement.

Grant Amount (Minus AIPP if applicable): [_____]

The Amount of this Notice of Obligation: [_____]

The Total Amount of all Previously Issued Notices of Obligation: [_____]

The Total Amount of all Notices of Obligation to Date: [_____]

Note: Contract amounts may exceed the total grant amount, but the invoices paid by the grant will not exceed the grant amount.

Department Rep. Approver: [_____]

Title: [_____]

Signature: [_____]

Date: [_____]

1 Administrative and/or Indirect Cost – generally, the legislation authorizing the issuance of bonds prohibits the use of its proceeds for indirect expenses (e.g. penalty fees or damages other than pay for work performed, attorney fees, and administrative fees). Such use of bond proceeds shall not be allowed unless specifically authorized by statute.

NMDOT ATTACHEMNT A

The City of Rio Communities shall agree to comply with the following Provisions:

1. Assume the lead role for the Project.
2. Be responsible for all applicable design, environmental and archaeological clearances, and right-of-way acquisition, in accordance with current local, state, federal laws, Uniform Relocation Act, and current design practices and specifications.
3. Be responsible for project development, project construction, construction management, and testing.
4. Utilize the Project Control Number in all correspondence and submittals to the Department.
5. Adopt a written resolution of support for the Project, including as applicable an assumption of ownership, liability, and maintenance responsibility for the scope, or related amenities and required funding to support the Project.
6. Complete the Project using current American Public Works Association (APWA) specifications, implemented Grantee's design standards and specifications, or Department specifications.
7. Use Rental Rate Blue Book rates, if not provided in the Department established equipment rates, in the implementation of this Project. Any equipment rates not found in the Department established rates shall be reimbursed at the Blue Book rates.

The City of Rio Communities shall agree to comply with the following Lighting and Signal Provisions as applicable:

1. After subject signal system(s) has/have been constructed, make provisions for and provide, at its own expense, all electrical energy, routine maintenance such as lamp replacement, emergency shutdown in case of accidental damage or equipment failure and make any repairs necessary due to accidental damage to, or equipment failure of, the signal head and poles.
2. In the event that accidental damage or equipment failure should occur, provide for equipment shut down/or emergency traffic control as needed. In addition, should the accidental damage or equipment failure involve the Controller (and cabinet) or the loop detection system, promptly notify the Traffic Technical Support Bureau of the Department.
3. In the event that the traffic signal should be rendered completely inoperable as a result of accidental damage, secure the intersection with stop signs at all approach legs until such time as the traffic signal is made operable.
4. Make ample future provisions in its budget each year for the cost of maintaining and providing energy to the traffic signals and telephone service to the signal system and intersection lighting.
5. At its own expense, maintain the signal controller and control equipment (the "Controller") including and maintenance of the machine vision vehicle detection system with cameras and emergency vehicle pre-empt system and repair or replace the Controller in the event the Controller and/or cabinet is damaged or there is an equipment failure.
6. After the installation of the roadway lighting system, if any, provide any and all utilities, maintenance, and such other items as may be necessary of continued satisfactory operation of said subject lighting system.
7. Make all timing adjustments to the Signal Control equipment and review the Signal System(s) for efficient and satisfactory operation.
8. Obtain approval from the Department for all signal equipment prior to installation.
9. Require the construction contractor to name the Department and the Grantee as an additional insured in the construction contractor's general liability policy.
10. Enter into a Signalization and Lighting Agreement with the Department's Traffic Technical Support Bureau as required.