



DEPARTMENT OF THE ARMY
U.S. ARMY CORPS OF ENGINEERS, GALVESTON DISTRICT
2000 FORT POINT RD
GALVESTON, TEXAS 77550

January 26, 2024

Evaluation Branch

SUBJECT: Permit No. SWG-2008-01125; Letter of Permission Extension of Time

City of Port Lavaca
POC: Darren Gurley
202 North Virginia Street
Port Lavaca, Texas 77979

Dear Mr. Gurley:

This is in reference to your December 18, 2023 request, submitted on your behalf by Urban Engineering, to amend Department of the Army (DA) Permit SWG-2008-01125. The amendment will consist of a time extension to complete work including repair of the existing 189-foot timber breakwater, which contains (282) 4-inch by 12-inch timber sheets, along with (70) 12-inch diameter pilings. The project site is located in Lavaca Bay, at 106 South Commerce Street, in Port Lavaca, Calhoun County, Texas.

DA Permit SWG-2008-01125 was issued on July 19, 2012, and authorized installation of 30 linear feet of breakwater west of the existing channel and 45 linear feet of breakwater east of the existing channel. The project also includes repair of the existing 189-foot timber breakwater, which contains (282) 4-inch by 12-inch timber sheets, along with (70) 12-inch diameter pilings. Amendment (01) was issued on January 25, 2018, and authorized all work described above. Since issuance of the original permit, the 30-foot and 45-foot breakwaters have been constructed. Therefore, this extension of time authorizes repairs to the 189-foot breakwater only.

Your amendment request is approved, pursuant to Section 10 of the Rivers and Harbors Act of 1899. All work is to be performed in accordance with the enclosed plans in 5 sheets. The permit conditions, as amended, remain in full force and effect, with the exception of the time limit for completion. The time limit for completing the work authorized ends on December 31, 2029. If you find that you need more time to complete the authorized activity, submit your request for a time extension to this office for consideration at least one month before the above date is reached. This authorization is subject to all special conditions, which remain in full force and effect.

This permit decision does not address nor include any consideration for geographic jurisdiction on aquatic resources and shall not be interpreted as such. If you have any questions, please contact Julie Ruth by email Julia.C.Ruth@USACE.Army.Mil or by telephone at 409-766-6360. Please notify the Chief of the Compliance Branch in the

Galveston District Regulatory Division in writing by email at CESWGRegulatoryInbox@USACE.Army.Mil, upon completion of the authorized project.

FOR THE DISTRICT COMMANDER:

A handwritten signature in blue ink that reads "K Marie Taylor". The signature is written in a cursive, flowing style.

K. Marie Taylor
Leader, Central Evaluation Unit

cc w/Encl.
Urban Engineering, Matt Glaze

Eighth Coast Guard District, New Orleans, LA

National Oceanic and Atmospheric Administration (NOAA), National Ocean Service (NOS), Coast & Geodetic Survey, Silver Spring, MD

Texas Commission on Environmental Quality

Texas General Land Office

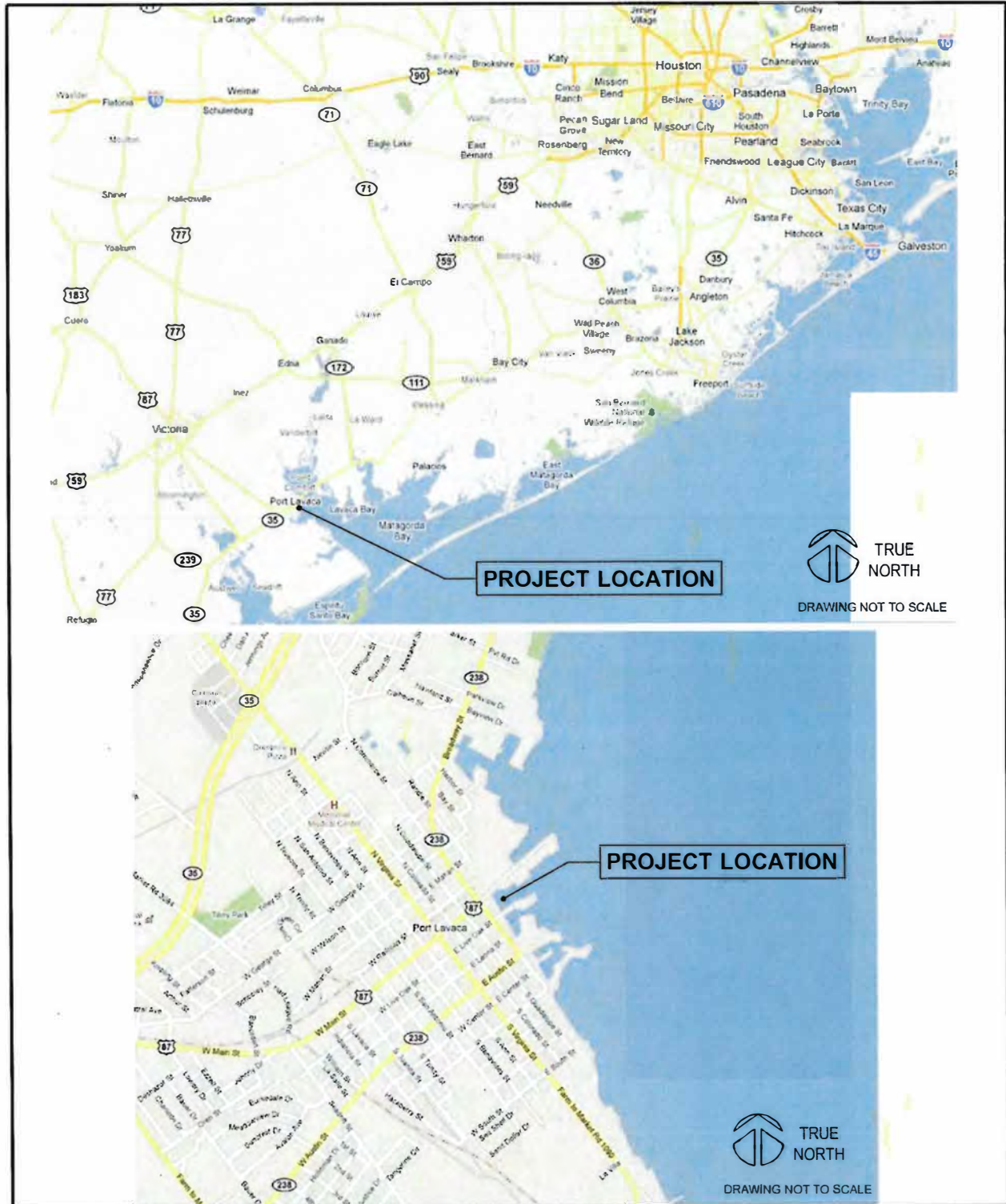

2004 N. Commerce
Victoria, Texas 77901
TREF# F-160

Tel (361) 578-9836
Fax (361) 576-9836
www.urbanvictoria.com

PROJECT

LOCATION MAP

SHEET 1 OF 5

NAUTICAL LANDINGS MARINA BREAKWATER
CITY OF PORT LAVACA, TX

JOB #: E17567.00 DATE: 08/05/11

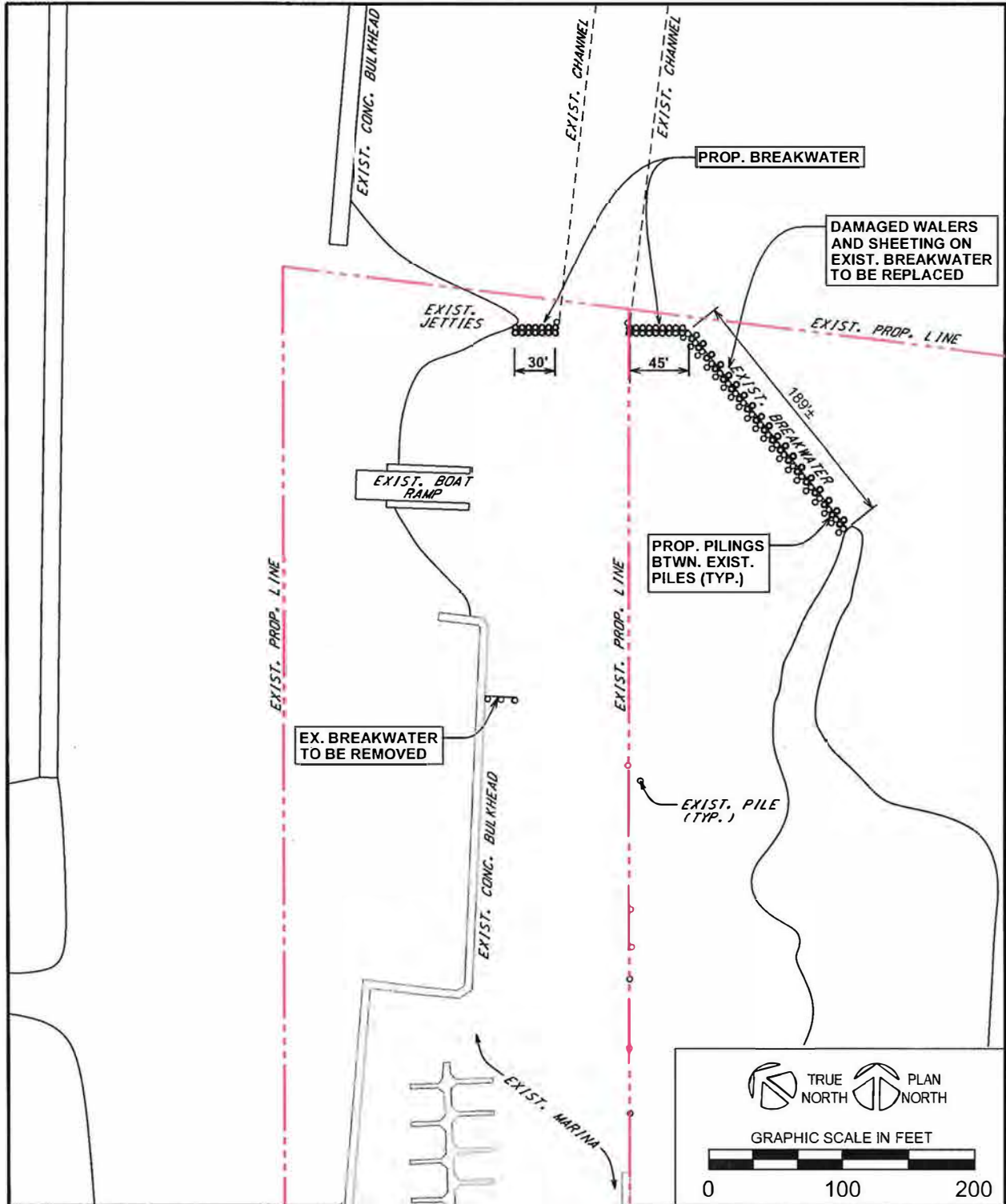

2004 N. Commerce
Victoria, Texas 77901
TREF# F-160

Tel (361) 578-9836
Fax (361) 576-9836
www.urbanvictoria.com

PROJECT

SITE PLAN

SHEET 2 OF 5

NAUTICAL LANDINGS MARINA BREAKWATER
CITY OF PORT LAVACA, TX

JOB #: E17567.00 DATE: 08/05/11

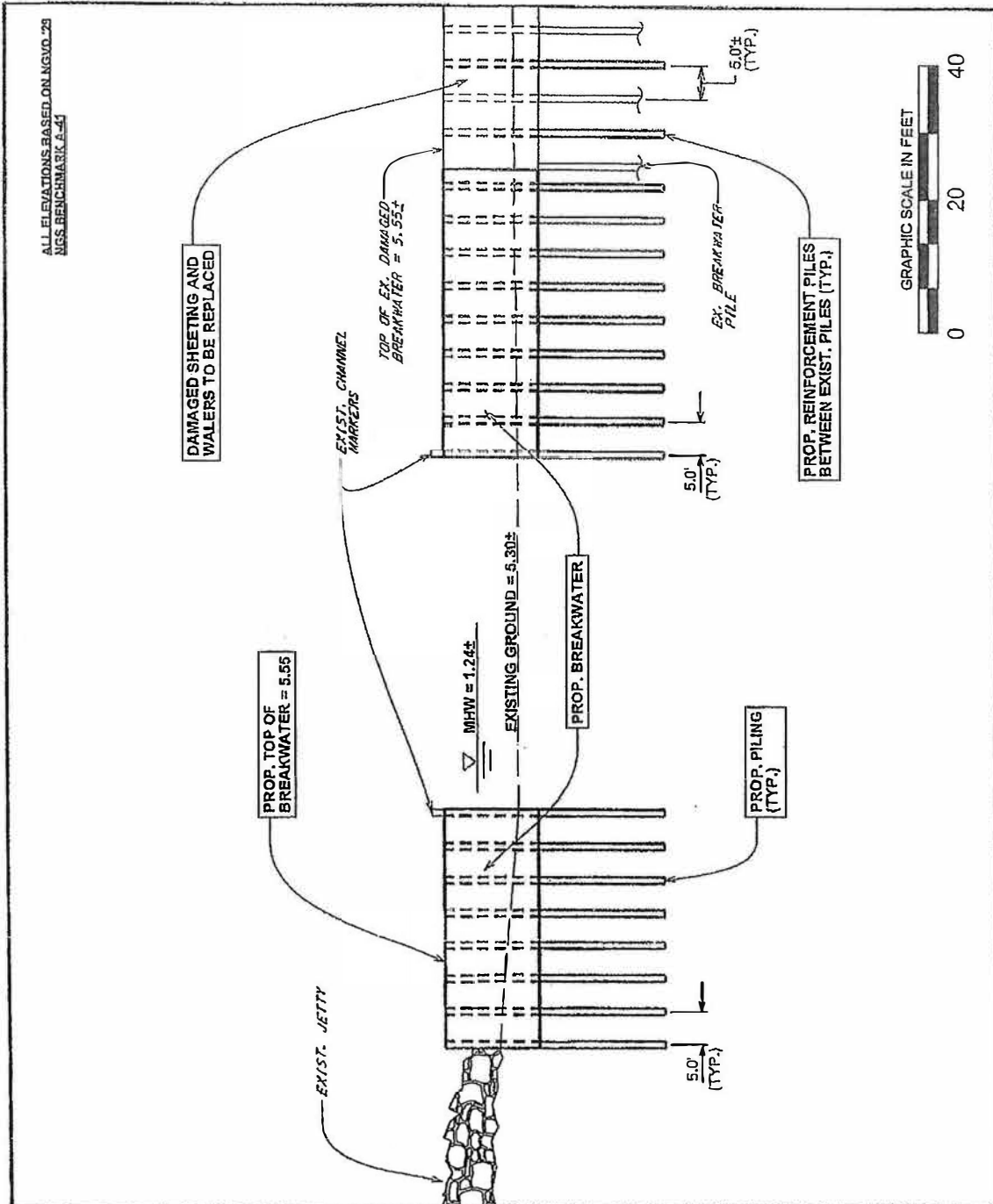

2004 N. Comarca
 Victoria, Texas 77901
 TREF# F-160

Tel (361) 578-9636
 Fax (361) 578-9636
 www.urbanvictoria.com

PROJECT

CROSS SECTION

NAUTICAL LANDINGS MARINA BREAKWATER
 CITY OF PORT LAVACA, TX

SHEET 3 OF 4

JOB #: E17567.00 DATE: 08/05/11

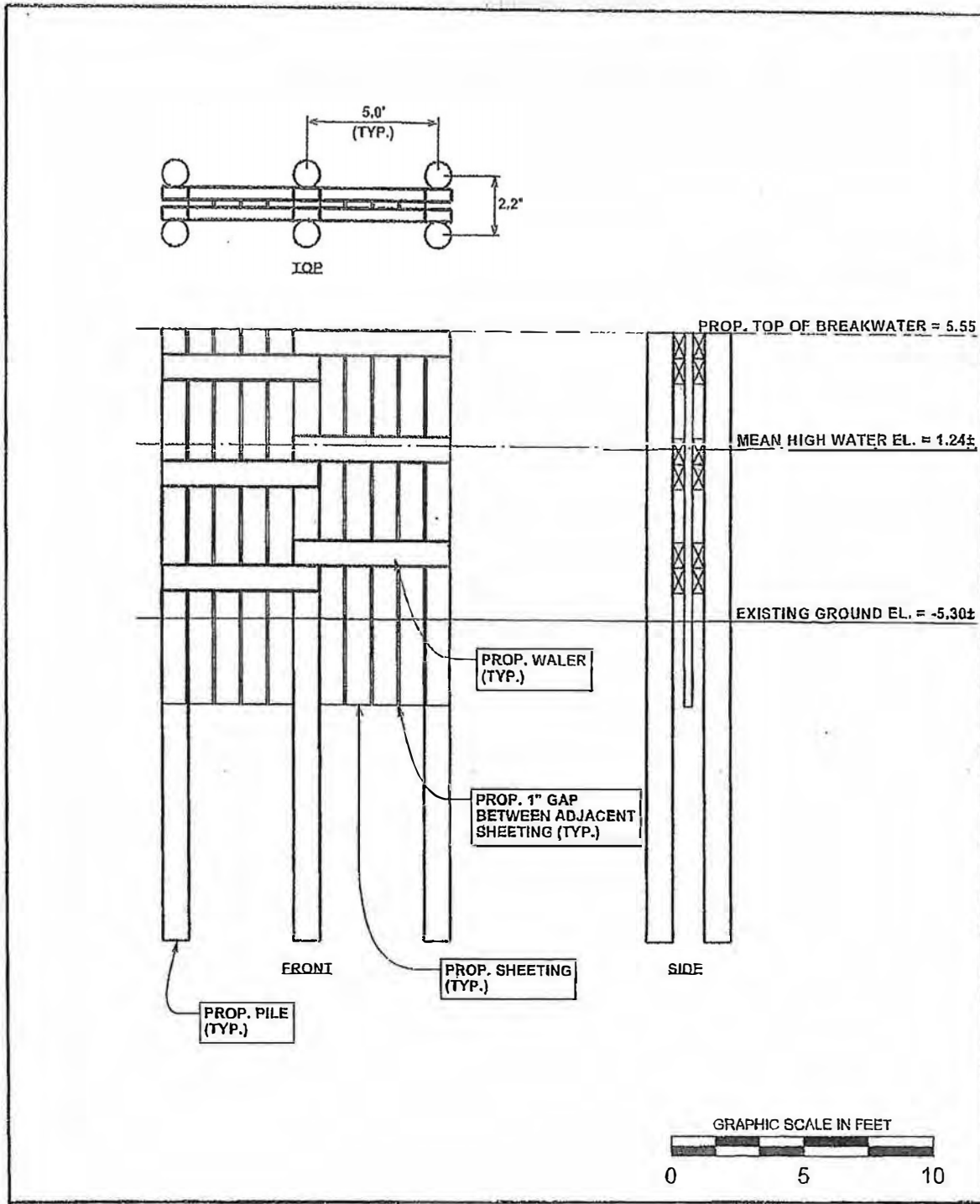

2004 N. Commerce
Victoria, Texas 77601
TEL# F-160

Tel (361) 578-9830
Fax (361) 576-9836
www.urbanvictoria.com

PROJECT SHEET 4 OF 5
PROP. BREAKWATER DETAILS
NAUTICAL LANDINGS MARINA BREAKWATER
CITY OF PORT LAVACA, TX
JOB #: E17567.00 DATE: 08/05/11

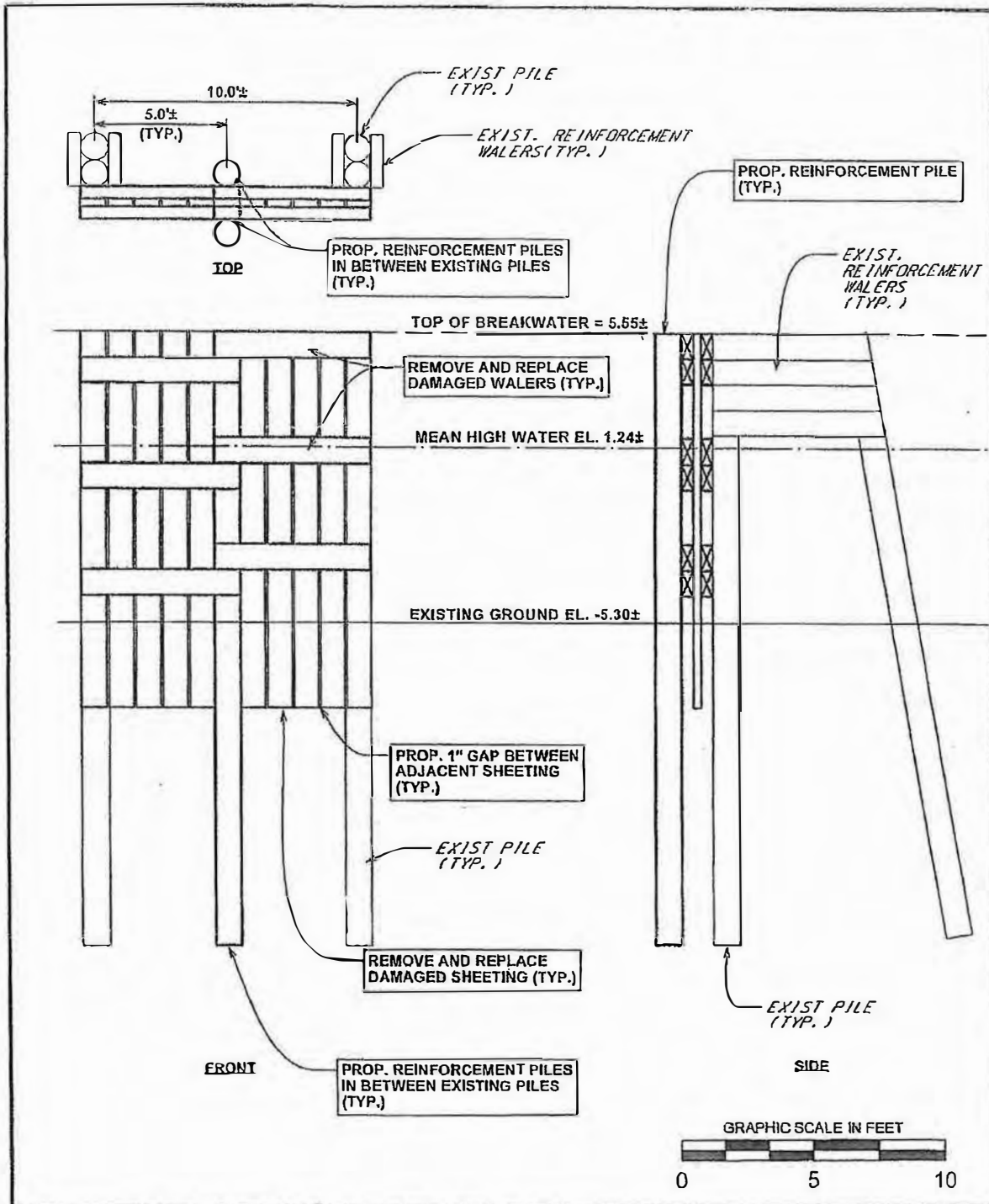

URBAN
 engineering

2004 N. Commerce
 Victoria, Texas 77901
 TREF# F-160

Tel (361) 578-9635
 Fax (361) 576-9836
 www.urbanvictoria.com

PROJECT **PROP. BREAKWATER REPAIR DETAILS**
 NAUTICAL LANDINGS MARINA BREAKWATER
 CITY OF PORT LAVACA, TX

SHEET 5 OF 5

JOB #: E17567.00 DATE: 08/05/11