



42 Valley Crescent
 PO Box 208
 Palmer Lake, CO 80133
 Phone: (719) 481-2953
 Fax: (719) 488-9305
www.townofpalmerlake.com

TOWN OFFICE USE ONLY	
Date Received: _____	By: _____
Payment #: _____	Fee: \$ _____
<input type="checkbox"/> Approved	By: _____
<input type="checkbox"/> Denied	Date: _____

TOWN OF PALMER LAKE SIGN PERMIT APPLICATION

The following application is pursuant to Municipal Code Chapter 14.50 and must be completed for all types of signage in the Town of Palmer Lake. The application fee is \$100.00, which includes a nonrefundable \$15.00 fee for application processing, regardless of approval, denial, or applicant withdrawal.

The following documents must be submitted for this application to be considered:

- Completed Sign Permit Application
- Applicable fees
- Sketch of sign, including colors, dimensions, wording, and specific location of sign

This application and all required associated documents shall be submitted to the Town of Palmer Lake prior to scheduling before the Planning Commission. The Planning Commission meets monthly on the third Wednesday. Submission of application does not guarantee approval.

Note: A minimum of 10 days is required to process this application.

APPLICANT/BUSINESS OWNER INFORMATION

Business Name/Owner: Irene Ortiz-Colella

Phone: (303) 842-9984 Email: Threefarmgirls.shop@gmail.com

Street Address: 292 Highway 105 City: Palmer Lake State: CO Zip: 80133

Legal Address: Lot(s): _____ Block: _____ Subdivision: _____

Mailing Address (if different than physical location): _____

City: _____ State: _____ Zip: _____

Applicant Name (if other than owner): Irene Ortiz-Colella

Phone: (303) 842-9984 Email: Threefarmgirls.shop@gmail.com

Street Address: 11571 Spring Valley Rd City: Larkspur State: CO Zip: 80118

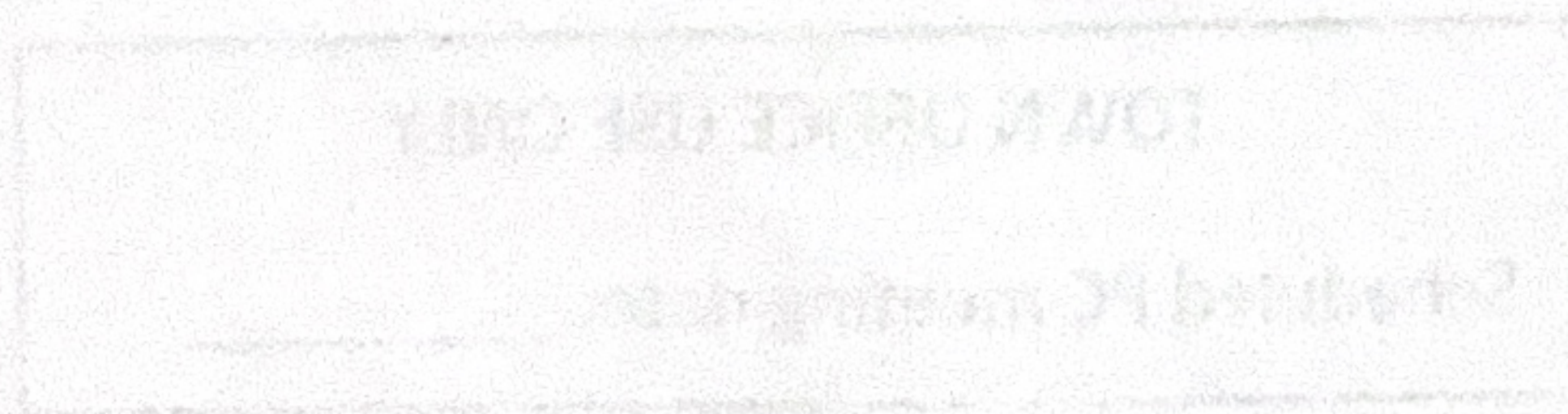

SIGN & FEE INFORMATION

The fee for this application is \$100.00. If requesting more than one sign, a separate application must be completed for each sign.

A sketch of the intended sign, including colors, dimensions, and location of the building or structure to which the sign will be attached, must be included with this application.

TYPE OF SIGN (check all that apply):

Double-Faced
 Projecting

Free-Standing
 Single-Faced

Multi-Faced
 Wall-Mounted

SIGN CATEGORY (check all that apply):

Business
 Marquee
 Temporary Sign

Comprehensive Sign Plan
 Master Plan
 Other: _____

Directory Sign
 PUD Sign

Sign Wording: Three Farm Girls Local Artisan Shop & Eatery

Specific Location of Sign: _____

Dimensions of Sign: L 53 x W 3 inch x H 60 Dimensions of Sign Structure: L 84 inch x W 6 inch x H 90

Colors: Natural wood color with Black metal. Materials: wood & metal

Will sign be illuminated? Yes No If yes, describe: spot light reflecting on sign.

How will the sign be mounted/affixed? Attached to sign structure with 3 post.

THIS APPLICATION HAS BEEN EXAMINED AND COMPLETED BY ME. ALL OF THE INFORMATION COMPLETED IN THIS APPLICATION AND ALL ATTACHMENTS ARE TRUE, CORRECT, AND COMPLETE TO THE BEST OF MY KNOWLEDGE. I AM AWARE OF AND FULLY UNDERSTAND THE TOWN OF PALMER LAKE REGULATIONS.

[Handwritten Signature]

Irene Ortiz-Colella 3/17/25

Signature

Printed Name

Date

TOWN OFFICE USE ONLY
Scheduled PC meeting date: _____

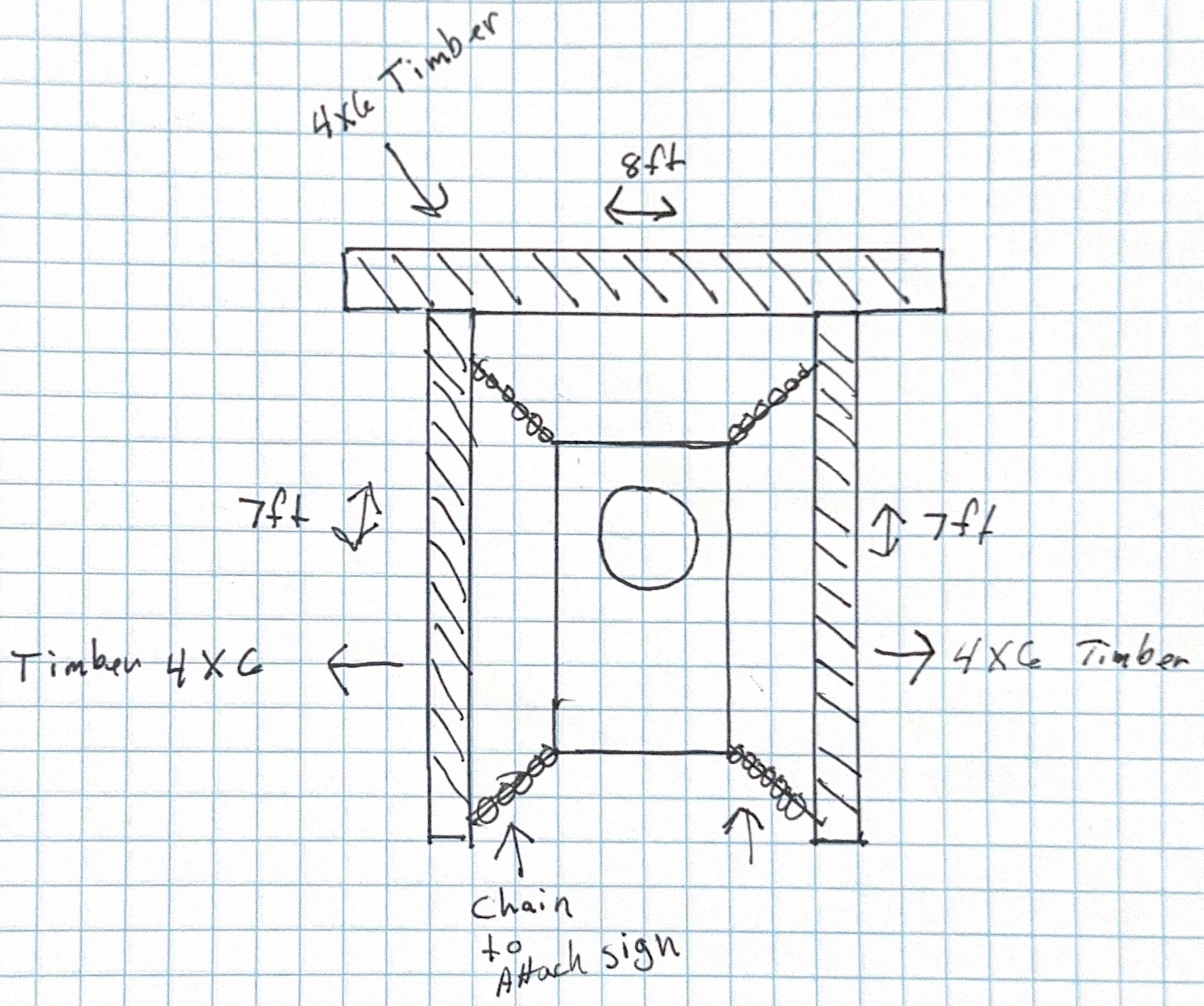

Local
 Artison
 Eatery
 &
 Shop