



42 Valley Crescent
 PO Box 208
 Palmer Lake, CO 80133
 Phone: (719) 481-2953
 Fax: (719) 488-9305
 www.townofpalmerlake.com

TOWN OFFICE USE ONLY

Date Received: 3/2025 By: VAC
 Payment #: _____ Fee: \$ _____
 Approved By: _____
 Denied Date: _____

TOWN OF PALMER LAKE SIGN PERMIT APPLICATION

The following application is pursuant to Municipal Code Chapter 14.50 and must be completed for all types of signage in the Town of Palmer Lake. The application fee is \$100.00, which includes a nonrefundable \$15.00 fee for application processing, regardless of approval, denial, or applicant withdrawal.

The following documents must be submitted for this application to be considered:

- Completed Sign Permit Application
- Applicable fees
- Sketch of sign, including colors, dimensions, wording, and specific location of sign

This application and all required associated documents shall be submitted to the Town of Palmer Lake prior to scheduling before the Planning Commission. The Planning Commission meets monthly on the third Wednesday. Submission of application does not guarantee approval.

Note: A minimum of 10 days is required to process this application.

APPLICANT/BUSINESS OWNER INFORMATION

Business Name/Owner: Irene ORTIZ-COLELLA
 Phone: (303) 842-9984 Email: Threefarmgirls.shop@gmail.com
 Street Address: 292 Highway 105 City: Palmer Lake State: CO Zip: 80133
 Legal Address: Lot(s): _____ Block: _____ Subdivision: _____
 Mailing Address (if different than physical location): _____
 City: _____ State: _____ Zip: _____
 Applicant Name (if other than owner): Irene ORTIZ-COLELLA
 Phone: (303) 842-9984 Email: Threefarmgirls.shop@gmail.com
 Street Address: 11571 Spring valley Rd City: Larkspur State: CO Zip: 80118

SIGN & FEE INFORMATION

The fee for this application is \$100.00. If requesting more than one sign, a separate application must be completed for each sign.

A sketch of the intended sign, including colors, dimensions, and location of the building or structure to which the sign will be attached, must be included with this application.

TYPE OF SIGN (check all that apply):

- Double-Faced
- Projecting
- Free-Standing
- Single-Faced
- Multi-Faced
- Wall-Mounted

SIGN CATEGORY (check all that apply):

- Business
- Marquee
- Temporary Sign
- Comprehensive Sign Plan
- Master Plan
- Other: _____
- Directory Sign
- PUD Sign

Sign Wording: Three Farm Girls Local Artisan Shop & Eatery

Specific Location of Sign: in front of porch (fronting walkway)

Dimensions of Sign: L 53 x W 33 x H 60 Dimensions of Sign Structure: L 84 x W 60 x H 90

Colors: Natural wood color with black metal. Materials: wood & metal

Will sign be illuminated? Yes No If yes, describe: spot light reflecting on sign.

How will the sign be mounted/affixed? Attached to sign structure with 3 post.

THIS APPLICATION HAS BEEN EXAMINED AND COMPLETED BY ME. ALL OF THE INFORMATION COMPLETED IN THIS APPLICATION AND ALL ATTACHMENTS ARE TRUE, CORRECT, AND COMPLETE TO THE BEST OF MY KNOWLEDGE. I AM AWARE OF AND FULLY UNDERSTAND THE TOWN OF PALMER LAKE REGULATIONS.

[Signature]
Signature

Irene Ortiz-Colella 3/17/25
Printed Name

Date

TOWN OFFICE USE ONLY
Scheduled PC meeting date: 4/16/25

Dawn Collins

From: April Veley <veley9@hotmail.com>
Sent: Thursday, March 27, 2025 8:51 PM
To: Dawn Collins
Subject: Written consent for property use

Follow Up Flag: Flag for follow up
Flag Status: Flagged

-----WARNING: This email originated from outside the Town of Palmer Lake. DO NOT CLICK on any attachments or links from unknown senders or unexpected emails. Always check the sender's display name and email address are correct before you communicate.-----

Hi Dawn,

Writing you on behalf of Irene and 3 Farm Girls Market and Eatery, we plan on entering into a lease in the very near future and have no issue with signage being placed at 292 hwy 105.

Please let me know if you need anything from me.

Thanks
April Fullman
719-323-8816

Sent via the Samsung Galaxy A13, an AT&T 4G LTE smartphone
[Get Outlook for Android](#)



LOCAL ARTISAN SHOP
&
EATERY

Irene



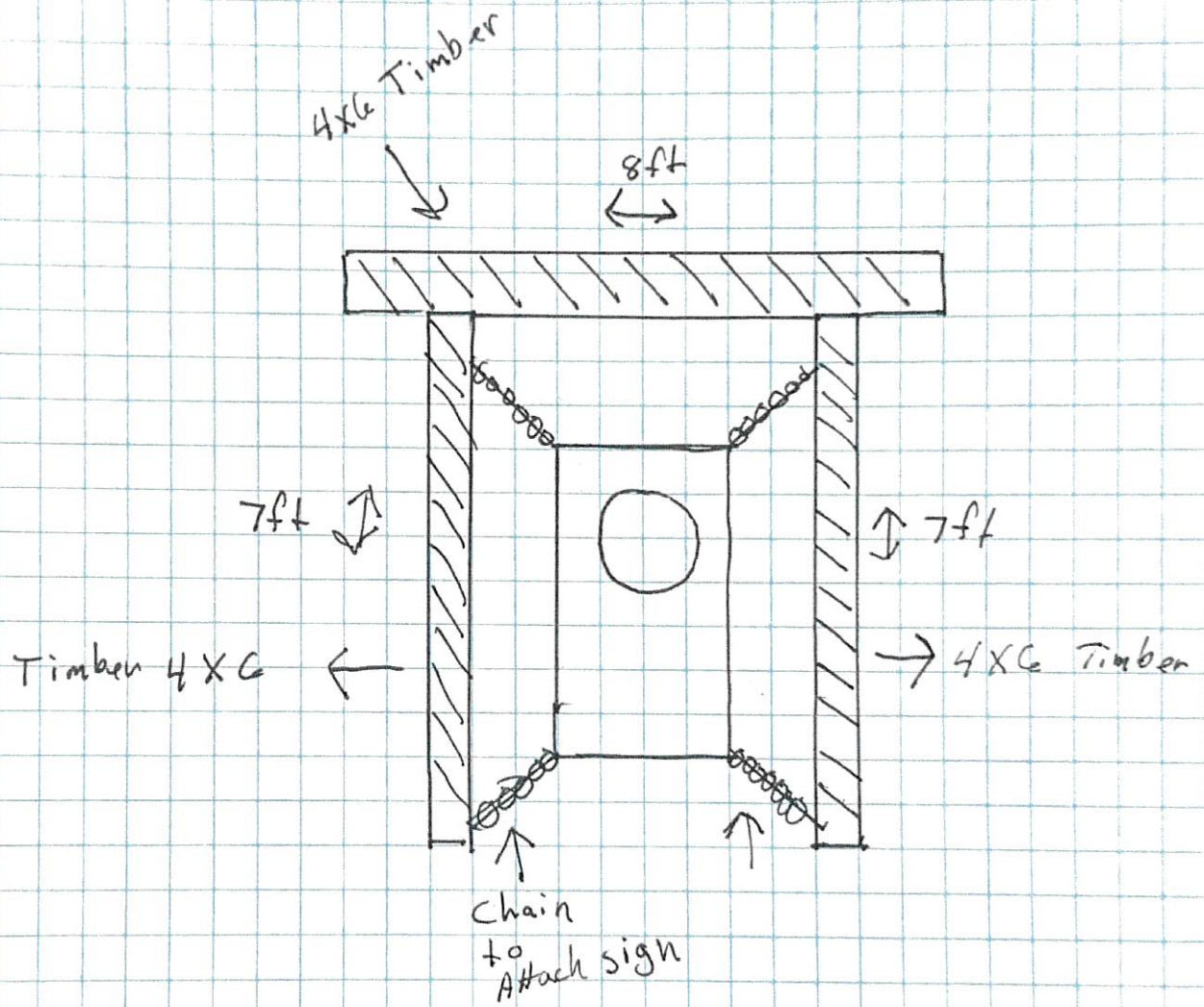

Local
Artison
Eatery
&
Shop