

FEDERAL AVIATION ADMINISTRATION

CIP DATA SHEET

CAPITAL IMPROVEMENT PROGRAM (CIP)
AIRPORTS DIVISION - CENTRAL REGION

Original Project

SEE INSTRUCTIONS TO COMPLETE THIS INFORMATION			
Airport Name, LOCID, City, State:	Oelwein Municipal Airport, OLZ, Oelwein, IA		
AIP Project Type:	Pavement Rehabilitation – Hangar Area		
Local Priority:	1 - Very High	Fed. Share (AIP):	\$ 380,950
FFY Requested:	2026	Fed. Share (IIJA):	\$Click here to enter text.
NEPA Determination:	Click here to enter text	State Share:	\$Click here to enter text.
Provide Detailed Project Scope and Justification Below. You must attach a sketch/drawing (on a separate sheet) that clearly identifies the scope of the project.	Local Share:		\$20,050
	Total Project Cost:		\$ 401,000

Project will include reconstruction of the existing asphalt section of taxiway pavement and repair/replace concrete panels for taxiway and hangar approach pavements in the west general aviation hangar area. The 2022 Pavement Evaluation Study showed that the PCI values for the asphalt pavements in this area were in the low 40's while the concrete pavements were in the 60's.

Oelwein Municipal Airport – Pavement Management Report (2022)

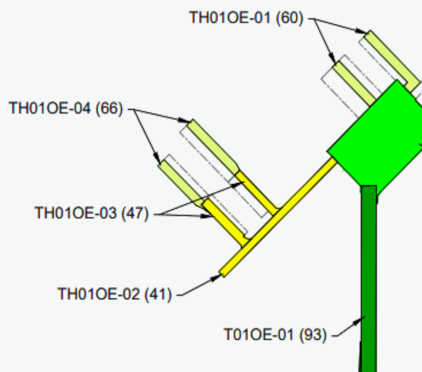

SPONSOR SIGNATURE BLOCK

Signature:		Date:	12/19/2025
Printed Name:	Dylan Mulfinger	Title:	City Administrator
Phone Number:	(319) 283-5440	Email:	DMulfinger@cityfoelwein.org

Oelwein Municipal Airport
 ACIP Data Sheet Cost Estimate
 Pavement Rehabilitation - Hangar Area
 December 18, 2025

Original Project

Item	Unit	Quantity	Unit Price	Total
Mobilization and Safety	LS	1	\$ 30,000.00	\$ 30,000.00
PCC Removals	SYD	400	\$ 50.00	\$ 20,000.00
PCC Replacement	SYD	400	\$ 225.00	\$ 90,000.00
Pavement Removal	SYD	2600	\$ 15.00	\$ 39,000.00
Unclassified Excavation	CYD	1800	\$ 30.00	\$ 54,000.00
Aggregate Base Course	CYD	450	\$ 50.00	\$ 22,500.00
Asphalt Pavement	TONS	700	\$ 150.00	\$ 105,000.00
Joint Sealing PCC Pavement	LFT	2500	\$ 3.00	\$ 7,500.00
Subdrain	LFT	1000	\$ 10.00	\$ 10,000.00
Engineering, Legal, Administration				\$ 53,000.00

TOTAL

\$ 401,000.00

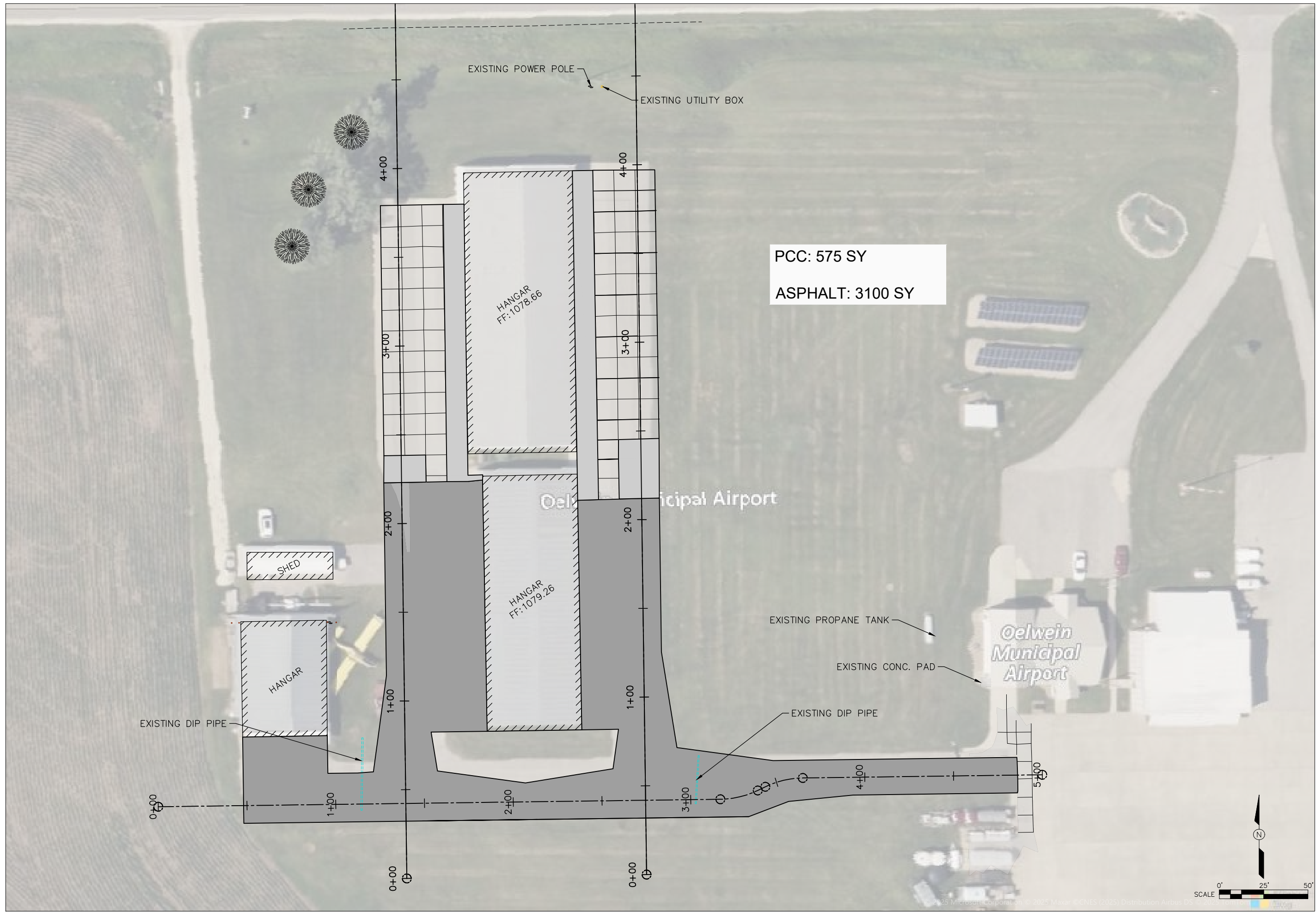

NO	REVISIONS	DRN	CHK	DATE

DRN	McBride, Dorn
DES	
CHK	
APP	
Copyright © AECOM All Rights Reserved	

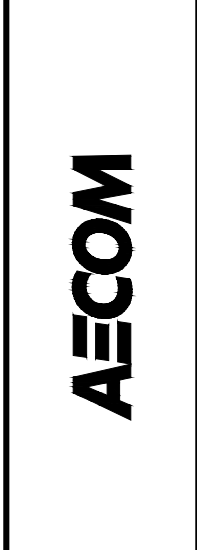

OLZ T-Hanger Taxi Rehab
 GEOMETRY EXHIBIT

DATE	3/17/2026
PROJECT NO.	60777499
MILESTONE	PRELIMINARY PLANS
SHEET NO.	
DRAWING NO.	

RECONSTRUCT T-HANGAR TAXILANES
 FLEXIBLE PAVEMENT RECONSTRUCTION
 OELWEIN MUNICIPAL AIRPORT
 CITY OF OELWEIN, IOWA
 FAA AIP PROJECT NO. 3-19-0067-016
 AECOM PROJECT NO. 60777499

New Proposed Price

March 16, 2026

ITEM No.	SPECIFICATION SECTION	ITEM DESCRIPTION	UNIT	ESTIMATED QUANTITY	ESTIMATED UNIT PRICE	ESTIMATED AMOUNT
1	P-100	MOBILIZATION AND DEMOBILIZATION	LS	1.0	\$ 53,000.00	\$ 53,000.00
2	P-101	PAVEMENT REMOVAL	SYD	2,900.0	\$ 15.00	\$ 43,500.00
3	P-152	UNCLASSIFIED EXCAVATION	CY	3,300.0	\$ 15.00	\$ 49,500.00
4	P-154	FROST PROTECTION COURSE	CY	1,900.0	\$ 35.00	\$ 66,500.00
5	P-208	SUBBASE COURSE - 6"	CY	620.0	\$ 40.00	\$ 24,800.00
6	PLANS	GEOGRID	SYD	4,400.0	\$ 5.00	\$ 22,000.00
7	P-156	INSTALLATION AND REMOVAL OF SEDIMENT LOGS	LF	1,100.0	\$ 5.00	\$ 5,500.00
8	P-403	HOT MIX ASPHALT (HMA) - 4"	TON	750.0	\$ 110.00	\$ 82,500.00
9	P-501	PORTLAND CEMENT CONCRETE (PCC) PAVEMENT - 5"	SYD	580.0	\$ 60.00	\$ 34,800.00
10	P-602	BITUMINOUS PRIME COAT	GAL	1,100.0	\$ 7.00	\$ 7,700.00
11	P-603	BITUMINOUS TACK COAT	GAL	300.0	\$ 7.00	\$ 2,100.00
12	D-705	SUBDRAIN - 4"	LF	1,100.0	\$ 25.00	\$ 27,500.00
13	D-705	SUBDRAIN CLEANOUTS	EA	10.0	\$ 1,600.00	\$ 16,000.00
14	D-701	RCP - 12"	LF	115.0	\$ 90.00	\$ 10,350.00
15	D-701	FLARED END SECTIONS	EA	4.0	\$ 2,500.00	\$ 10,000.00
16	P-605	PCC PAVEMENT JOINT RESEALING	LF	870.0	\$ 5.00	\$ 4,350.00
17	P-605	CRACK ROUTING AND SEALING	LF	250.0	\$ 8.00	\$ 2,000.00
18	P-620	REFLECTIVE MARKING, YELLOW	SF	550.0	\$ 4.50	\$ 2,475.00
19	P-620	NON-REFLECTIVE MARKING, BLACK	SF	1,050.0	\$ 4.00	\$ 4,200.00
20	L-110	4-INCH SPLIT DUCT - CONCRETE ENCASED	LF	500.0	\$ 25.00	\$ 12,500.00
21	T-901	SEEDING	AC	0.30	\$ 1,800.00	\$ 540.00
22	T-908	MULCHING	AC	0.30	\$ 3,200.00	\$ 960.00
23	T-905	TOPSOILING (OBTAINED ON-SITE)	CY	80.0	\$ 85.00	\$ 6,800.00
TOTAL ESTIMATE OF PROBABLE CONSTRUCTION COST:						\$ 489,575.00