



Fritel and Associates, LLC DBA
Diversified Product Development
700 Research Avenue
WACO, TX 76705
Phone: 254-757-1177
Fax: 254-757-1188

City of Needles
Justin Scott
817 Third Street
Needle, CA 92363

Phone: 760-490-9024
Email: jscott@cityofneedles.com
Date: 8/19/2024
Quote #: Q-240726TF-01A

Thank you for the opportunity to quote the items listed below. Choose one of our two Mast size listed below. Also listed below are the option(s) available with the LineWise TLL - 300D. Please review all pricing and information and let me know if you have any questions.

Table with 3 columns: Part Number, Description of Part(s), and Price (ea.) in USD. It lists various components for a TLL-300D digger derrick, including fiberglass cross arms, adapters, masts, wire holders, sliders, and a storage container, with a total price of \$33,500.

Basic terms:

- Written quotations automatically expire 30 calendar days from the date issued.
All shipping is FOB ORIGIN.
To provide you with the quickest delivery at the best pricing Diversified ships "Best Way, Prepay, and Add".
Diversified ships dedicated (FTL) or partially dedicated (PTL) only.
Diversified will capture the lowest cost available for shipping and add the cost to the invoice.
Allowing Diversified to do this will ensure timely pickup and delivery.
If this shipping method goes against a customer's shipping policies, Diversified's Inside Sales Specialist will work with the customer to provide an alternate method.
A handling fee of 10% of the total shipping cost is not included in this quote and will be added to the final invoice.

THIS QUOTATION SUPERSEDES ALL PREVIOUS QUOTATIONS. PLEASE SEE TERMS and CONDITIONS AND WARRANTY ATTACHED



- All international shipping arrangements and costs are the responsibility of the customer. Diversified will provide information and support as needed.

Payment Terms: Net 30. All International orders require a 50% down payment prior to the start of work, with payment in full prior to shipping. All past due invoices are subject to a finance charge of 15% per annum calculated daily. If payment is by credit card, a 4% finance charge will be added to the total bill. When a purchase order is received without the crane's engineering details or the necessary details from the customer to complete the order, an invoice will be sent to the customer for all items completed except those waiting on the specific information needed to complete the order. A separate invoice will be sent for pending items upon completion.

Send purchase order requests to sales@Line-Wise.com.

Best Regards,

Tammy Frosch
Inside Sales Specialist

THIS QUOTATION SUPERSEDES ALL PREVIOUS QUOTATIONS.
PLEASE SEE TERMS and CONDITIONS AND WARRANTY ATTACHED



(254) 757-1177

line-wise.com

sales@line-wise.com



700 Research Avenue
Waco, Texas 76705



TLL-300D for Digger Derrick (12" mast)

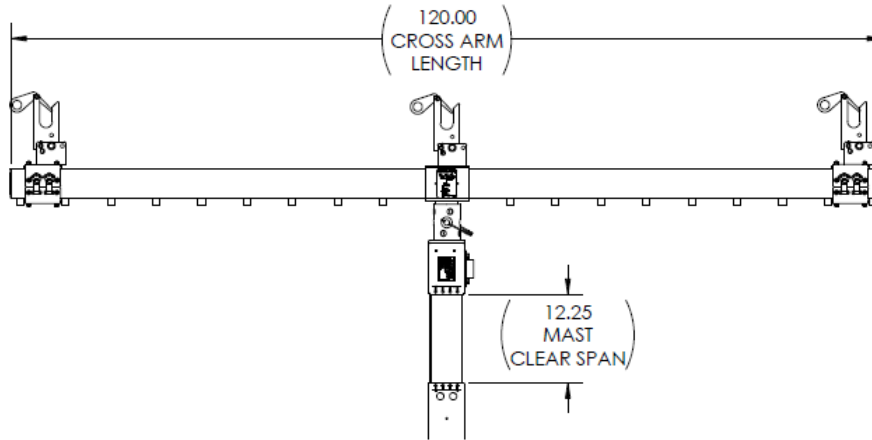

TLL-300D for Digger Derrick (31" mast)

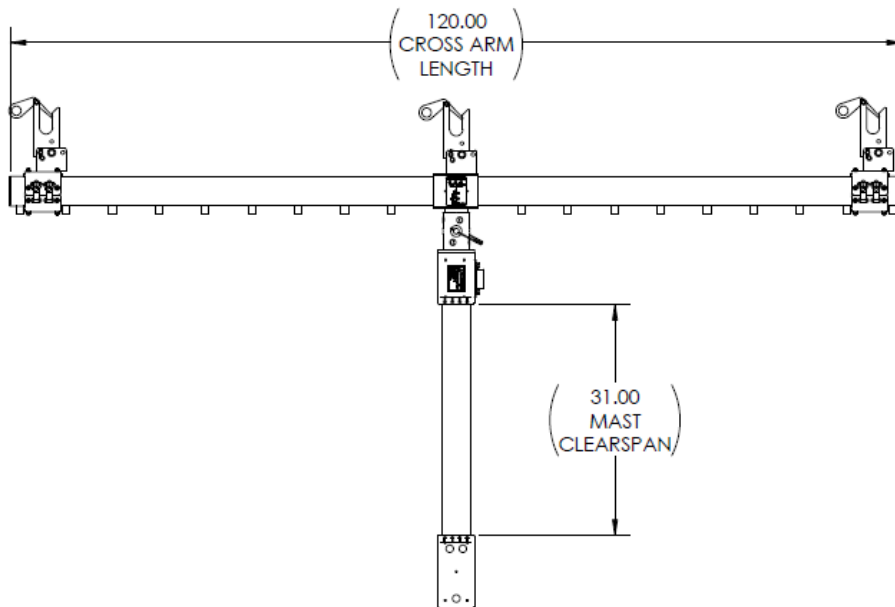

THIS QUOTATION SUPERSEDES ALL PREVIOUS QUOTATIONS.
PLEASE SEE TERMS and CONDITIONS AND WARRANTY ATTACHED

Adapter - Altec

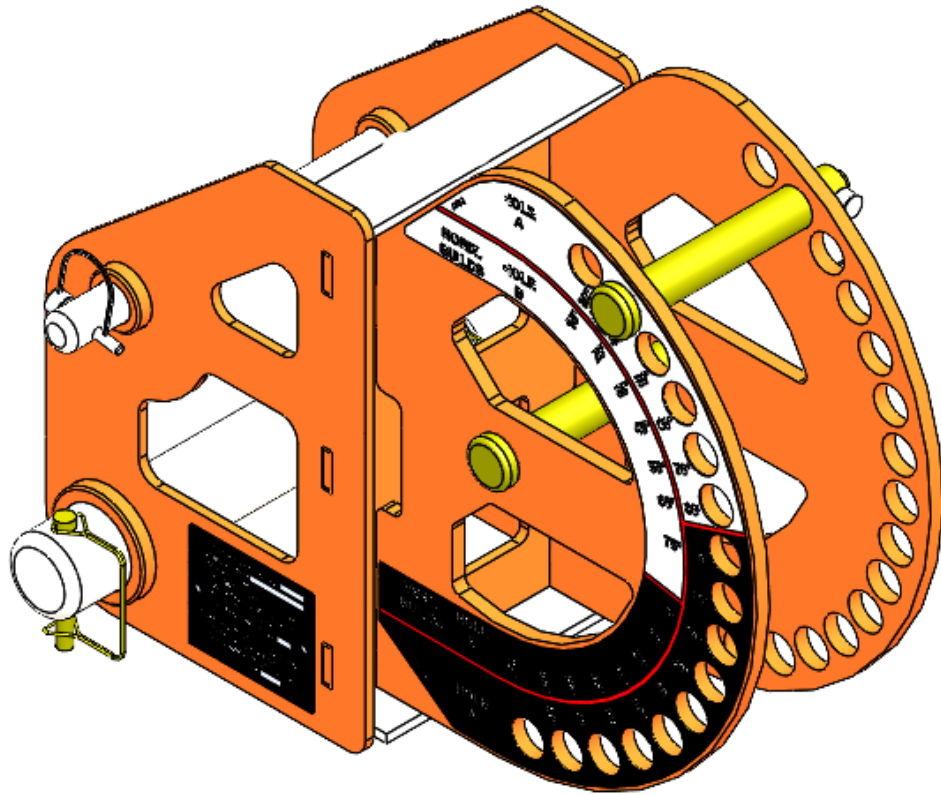

Swing Gaete Wire Holder

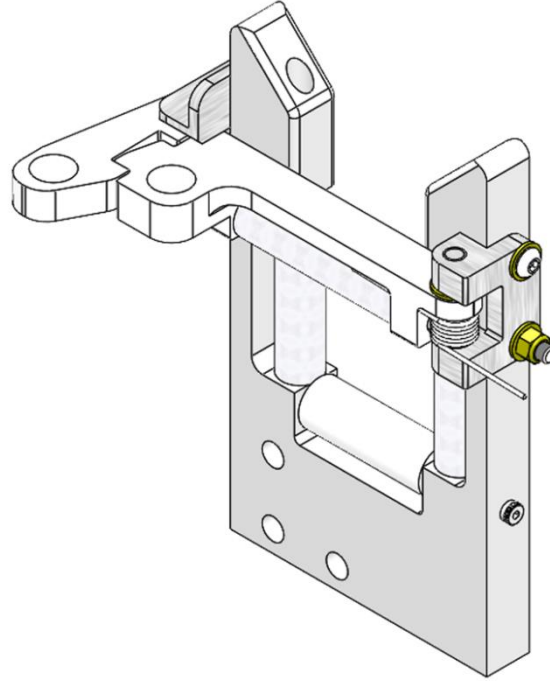

Roller Wire Holder

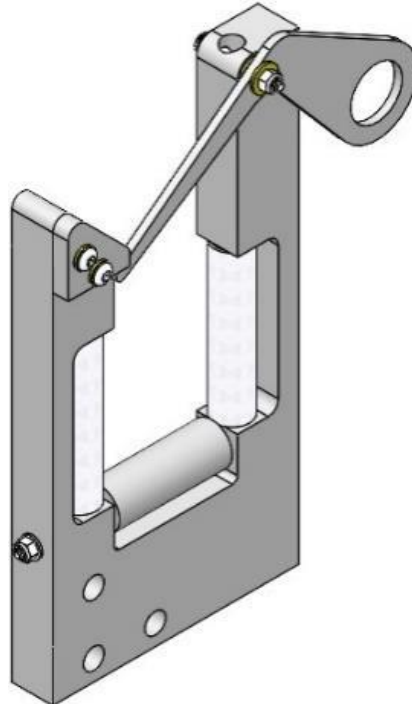

TERMS AND CONDITIONS

- 1. ORDER ACCEPTANCE.** All orders or services are subject to acceptance in Texas by the written approval of an authorized official of Diversified Product Development LLC. ("Diversified Product Development"). Any such order shall be subject to these Terms and Conditions of Sale ("Terms"), and acceptance shall be conditioned on assent to such conditions. Any additional or different terms already or hereafter proposed by purchaser, whether in a purchase order or other communication, are hereby rejected and shall not apply.
- 2. CANCELLATION AND ALTERATIONS.** No order accepted by Diversified Product Development may be altered or modified by purchaser unless agreed to in writing signed by an authorized official of Diversified Product Development.
- 3. QUOTATION AND PRICES.** Written quotations automatically expire 10 calendar days from the date issued unless sooner terminated by notice. All published prices and discounts are subject to change without notice. Any addition to an outstanding order will be accepted at prices in effect when the addition is accepted. Prices on orders in effect for over 10 days are subject to being changed to current prices. Pricing is based upon preliminary information. Pricing is subjected to requote pending final review and approval from Diversified team. Send purchase order requests to sales@Line-Wise.com.
- 4. TERMS OF PAYMENT.** Net invoice amount is due within thirty (30) days from date of invoice. All past due invoices are subject to a finance charge of 15% per annum calculated daily. If payment is by credit card, there will be a 4% finance charge added to the total bill. All International orders require 50% down payment prior to start of work with payment in full prior to shipping.
- 5. SHIPPING TERMS.** All shipping is FOB ORIGIN. Diversified ships dedicated (FTL) or partially dedicated (PTL) only. The most appropriate shipping method is determined by the product being shipped (weight, size, delivery date, etc.). Diversified advises against shipping products LTL due to an increase in products being damaged or lost. LTL shipping arrangements and costs are the sole responsibility of the customer. A handling fee of 10% of the total shipping cost is not included in this quote and will be added to the final invoice for shipments arranged by Diversified. All international shipping arrangements and costs are the responsibility of the customer. Diversified will provide information and support as needed.
- 6. DELIVERY.** All quoted delivery dates are approximate and will depend upon prompt receipt from purchaser of down payment, purchase order and all engineering documentation necessary for the design and manufacture of the equipment by Diversified Product Development.
- 7. WARRANTY.** Diversified Product Development guarantees all its products to be free from defects in workmanship and material when operated under normal conditions and in accordance with characteristic limits. This warranty shall be in effect for 15 months from date of shipment from Diversified's facilities or 12 months from the time equipment is put into service, whichever comes first. THIS WARRANTY SHALL BE IN LIEU OF ANY OTHER WARRANTY, EXPRESS OR IMPLIED, INCLUDING, BUT NOT LIMITED TO, ANY IMPLIED WARRANTY OF MERCHANTABILITY OR FITNESS FOR A PARTICULAR PURPOSE. Diversified Product Development will repair or replace, at its option, any component which is found to be defective and is within the warranty period, provided that the component is shipped freight prepaid to Diversified Product Development, 700 Research Avenue, Waco, TX 76705. Diversified Product Development is not responsible for removal, installation, or any other incidental expenses incurred in shipping the product to or from Diversified Product Development. Diversified Product Development's liability under this warranty shall be solely limited to repair or replacement of components of the product within the warranty period, and DIVERSIFIED PRODUCT.