

**RECIPIENT AGREEMENT BETWEEN CITY OF MERIDIAN AND ANITA BURGESS
FOR FY22 NEIGHBORHOOD GRANT FUNDS**

This RECIPIENT AGREEMENT BETWEEN CITY OF MERIDIAN AND ANITA BURGESS FOR FY22 NEIGHBORHOOD GRANT FUNDS (“Agreement”) is entered into this 5 day of August, 2022 by and between the City of Meridian, a municipal corporation organized under the laws of the state of Idaho (“City”), and Anita Burgess, an individual person (“Recipient”).

WHEREAS, Meridian City Council has allocated fiscal year 2022 general funds for the purpose of awarding Neighborhood Grants to Meridian residents for projects that bring Meridian neighbors together and improve the community, as set forth in detail in *Exhibit A*; and

WHEREAS, Recipient has proposed to revitalize and expand the playground at Bear Creek Park by the addition of “Beep, Beep, Jeep!” equipment, as set forth in *Exhibit B* (“Project”), to give children and their families access to the power of play with attention to serving individuals with physical limitations, which activity complements the objectives of the Neighborhood Grant program; and

WHEREAS, the Project will be completed in conjunction with the ongoing construction project pursuant to City of Meridian Project # 10105.c, awarded to Garrett Parks + Play (“Vendor”), who has estimated that the cost of adding the Project to the scope of work will be \$43,196.56, as set forth in *Exhibit C*; and

WHEREAS, by this Agreement, City and Recipient wish to establish the roles and responsibilities of the Recipient related to the investment and utilization of fiscal year 2022 Neighborhood Grant funds provided to Recipient by City (“Funds”);

NOW, THEREFORE, in consideration of the mutual covenants of the parties, the Parties agree as follows:

I. RECIPIENT’S RESPONSIBILITIES; PROJECT ADMINISTRATION.

- A. Activities.** Funds, in the amount of thirty-six thousand, six hundred and ninety-seven dollars and fifty-six cents (\$36,697.56), will be granted to Project. Funds will only be used for completion of the Project. Use of the Funds shall be consistent with any and all terms and conditions of the Neighborhood Grant Program and this Agreement.

- B. Recipient Contribution.** Recipient shall be responsible for payment of the difference between the grant and the cost of the Project, which amount totals six thousand, four hundred and ninety-nine dollars (\$6,499.00) (“Recipient’s Contribution”). Recipient shall provide Recipient’s Contribution to City on or before August 12, 2022, at 5:00 p.m. The Finance Department of the City of Meridian (33 E. Broadway Avenue, Meridian, Idaho 83642) must receive payment in full by this time in order for Project to proceed.

- C. **Closeout.** Within thirty (30) days of completion of the Project, Recipient shall submit a final report to City. The final report shall include:
 - 1. Written narrative answering each and all of the following questions:
 - a. What did you accomplish, and how?
 - b. How were volunteers engaged and used, and how many?
 - c. What is the impact of this project on your neighborhood?
 - 2. Final project budget, showing use of Neighborhood Grant funds, partner organization funds, and in-kind and monetary donations.
 - 3. Photographs of Project completion and final Project.

- D. **Grant Disbursement Process.** Following receipt of Recipient's payment in the amount of \$6,499.00, and pursuant to City's financial policies and procedures, City will pay Vendor directly for the cost of completing Project. Vendor will complete Project in conjunction with the Bear Creek Park Meridian Project # 10105.c.

- E. **Performance monitoring.** City shall designate a Project Manager to oversee completion of Project pursuant to this Agreement. City's Project Manager shall monitor investment of the Funds to ensure that goals of the Project as set forth in *Exhibit B* and *Exhibit C* are being met. Performance monitoring shall include review of quotes, receipts, and other documents, as well as site visits, as appropriate. Project Manager shall notify Recipient of completion of the Project.

II. GENERAL PROVISIONS.

- A. **No agency; independent contractor.** It is understood and agreed the Recipient is not, and shall not be considered, an agent of City in any manner or for any purpose whatsoever. In all matters pertaining to this Agreement, Recipient shall be acting as an independent contractor, and neither Recipient nor any volunteer, employee, invitee, or agent of Recipient shall be deemed an employee of City. Recipient shall have no authority or responsibility to exercise any rights or power vested in City.

- B. **Photographs.** Recipient consents to City's publication and/or use of any photographs or recordings of Recipient; Recipient's volunteers, guests, invitees, agents, and employees; and/or the Project for educational and promotional purposes.

- C. **Acknowledgment of risk.** Recipient acknowledges that activity undertaken in conjunction with this Agreement presents risks to the recipient, some of which are unknown, and agrees to assume only those risks.

- D. **Notices.** Day-to-day communications between Recipient and the Project Manager shall occur by email or phone, as appropriate. All other notices to be provided under this Agreement shall be in writing and addressed as follows:

If to Recipient:
 ANITA BURGESS
 1905 W Merganser

If to City:
 City Attorney, City of Meridian
 33 East Broadway Avenue

Meridian, Idaho 83642
nitagem@msn.com

Meridian, Idaho 83642
cityattorney@meridiacity.org

Notices shall be personally delivered, sent by U.S. mail, postage prepaid, or e-mailed. Notice shall be deemed to have been given upon deposit in the U.S. mail, upon personal delivery to the party above specified, or upon sending of an email message.

- E. Default or breach; cure; termination.** If Recipient is in breach or default of any of the terms, covenants or conditions of this Agreement and fails or refuses to cure such breach or default within seventy-two (72) hours of written notice thereof, this Agreement, and all rights of Recipient, at City's option, may be terminated and forfeited without further notice or demand. If the Project is cancelled, Project Manager shall notify Recipient in writing of such cancellation. City shall refund Recipient's Contribution to Recipient within thirty (30) days of Recipient's written demand therefor, which must be submitted within thirty (30) days of the Project Manager's notice of cancellation. Only Project Manager's written notice of cancellation shall signify such event; delays or nonmaterial changes to the Project shall not constitute cancellation. Recipient's damages for any injury alleged under this Agreement shall be limited to the amount of Recipient's Contribution. In no event shall Recipient have any right to the Funds or any portion thereof.
- F. No Third-Party Beneficiaries.** This Agreement is intended for the benefit of the parties hereto and their respective permitted successors and assigns, and is not for the benefit of, nor may any provision hereof be enforced by, any other person.
- G. No waiver.** City's waiver on one or more occasion of any breach or default of any term, covenant or condition of this Agreement shall not be construed as a waiver of any subsequent breach or default of the same or a different term, covenant or condition, nor shall such waiver operate to prejudice, waive, or affect any right or remedy City may have under this Agreement with respect to such subsequent default or breach by Recipient.
- H. Nondiscrimination.** Both Parties warrant and agree that there shall be no discrimination against any person or group of persons on account of race, color, creed, religion, sex, marital status, national origin or ancestry, in the granting or expenditure of Funds or any activity associated with Project.
- I. Applicable law; nonappropriation.** This Agreement shall be governed by and construed in accordance with the statutes and constitution of the State of Idaho, including, without limitation, Article VIII, Section 3, of the Idaho Constitution and the Idaho Public Records Act. Recipient acknowledges that City is a governmental entity, and the validity of this Agreement is based upon the availability of public funding under the authority of its statutory mandate. Notwithstanding anything in this agreement to the contrary, City's obligations under this Agreement are subject to and dependent upon appropriations being made by Meridian City Council for such purpose.

- J. Compliance with laws.** Throughout the course of this Agreement, Recipient and each and all of Recipient's volunteers, employees, guests, invitees, and agents shall comply with any and all applicable federal, state, and local laws.
- K. Severability.** If any provision of this Agreement is found by a court of competent jurisdiction to be illegal, invalid, or unenforceable, the remainder of this Agreement shall not be affected.
- L. Exhibits.** All exhibits to this Agreement are incorporated by reference and made a part of hereof as if the exhibits were set forth in their entirety herein. In the event that the information in the exhibits conflict with a provision of this agreement, the terms of this agreement shall apply.
- M. Entire agreement.** This Agreement contains the entire agreement of the parties and supersedes any and all other agreements, agreements, or understandings, oral or written, whether previous to the execution hereof or contemporaneous herewith. No verbal or written inducements to execute this Agreement have been made to Recipient. In entering into this Agreement, Recipient relies upon no statement, fact, promise or representation, whether express or implied, written or oral, not specifically set forth herein in writing.
- N. Successors and assigns.** All of the terms, provisions, covenants and conditions of this Agreement shall inure to the benefit of, and shall be binding upon, each party and their successors, assigns, legal representatives, heirs, executors, and administrators.
- O. Advice of attorney.** Each party warrants and represents that in executing this Agreement, it has received independent legal advice from its attorneys or the opportunity to seek such advice.
- P. City Council approval required.** The validity of this Agreement shall be expressly conditioned upon City Council action approving the Agreement. Execution of this Agreement by the persons referenced below prior to such ratification or approval shall not be construed as proof of validity in the absence of Meridian City Council approval.

IN WITNESS WHEREOF, the parties hereto have executed this Agreement on the Effective Date first written above.

RECIPIENT:

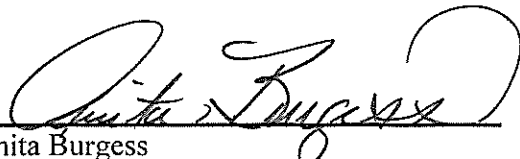
Anita Burgess

CITY OF MERIDIAN:

Attest:

Robert E. Simison, Mayor

Chris Johnson, City Clerk

EXHIBIT A



2021-2022 Neighborhood Grant Program

Overview of Neighborhood Grant Program

Meridian City Council has allocated \$50,000 for Neighborhood Grants, to be awarded to Meridian residents for projects that bring Meridian neighbors together and improve the community. Applicants may apply for Neighborhood Grant funds in any amount up to \$50,000, and may request funds for more than one project. Projects must be complete by September 9, 2022.

Timeline

Application period open:	March 21, 2022
Applications due:	May 13, 2022, 5:00 p.m.
Selection panel convenes:	By May 19, 2022
Applicants notified:	May 20, 2022
Signed agreement due:	May 27, 2022
Project completion:	September 9, 2022
Final report due:	September 15, 2022, 5:00 p.m.

Eligibility and Criteria

Projects funded with Neighborhood Grant funds must be located on public property located within the City of Meridian. Applicants must be residents of the City of Meridian. Upon selection of a project for funding, the City of Meridian will require the successful Applicant to enter into a grant recipient agreement establishing terms and conditions of the grant funds (sample agreement available upon request). In awarding Neighborhood Grants, the selection panel will consider the following criteria:

1. Capacity for neighbor engagement in Project implementation and final deliverable;
2. Contribution to improvement of neighborhood environment and sense of community;
3. Suitability of proposed Project for project site; and
4. Long-term viability and impact of proposed Project.

Application

To apply, Applicants must submit the following materials to the City Contact listed below. If applying for more than one grant, a separate application must be completed for each project.

1. Completed Grant Application form
2. Written narrative answering each and all of the following questions:
 - a. What do you propose to accomplish and how?
 - b. How do you plan to engage and use volunteers, specifically your neighbors, to help on the project? How many volunteers will be needed?

- c. What is the desired impact of this project on your neighborhood and how will you measure it?
 - d. What is the plan for long-term maintenance of items that will be purchased, built, or installed with the funds (if applicable)?
 - e. What is the priority of this Project (if applying for grant funds for more than one project)?
3. Detailed Project plan, including timeline with specific dates.
 4. Detailed Project budget, listing Neighborhood Grant funds, partner organization funds, and in-kind and monetary donations.
 5. Written permission from property owner allowing the use of the property for the proposed Project.
 6. If project involves collaboration or co-funding with other organizations or businesses on this project, a letter of support from each.

City Contact

Submit application and reporting materials to, and direct any questions to:

Molly Medenblik, Community Relations & Policy Advisor

Address: 33 E. Broadway Avenue, Meridian, Idaho 83642

Email: mmedenblik@meridiancity.org

Phone: 208-489-0535

Reporting Requirements

All projects must be completed by Friday, September 9, 2022. A final report must be submitted to the City Contact by Thursday, September 15, 2022. The final report must include:

1. Written narrative answering each and all of the following questions:
 - a. What did you accomplish, and how?
 - b. How were volunteers engaged and used, and how many?
 - c. What is the impact of this project on your neighborhood?
2. Final project budget, showing Neighborhood Grant funds, partner organization funds, and in-kind and monetary donations.
3. Receipts supporting final project budget.
4. Photographs of Project completion and final Project.
5. Check payable to City of Meridian for any unused funds.

Purchasing Requirements

If the proposed Project includes the purchase of goods, services, supplies, or equipment, purchases up to \$15,000 will require one written quote, and purchases \$15,001 to \$50,000 require three written quotes. Documentation will be required prior to release of funds.

Limitations

Neighborhood Grant funds may not be spent on gift cards, alcohol, tobacco, firearms, or travel. Funds will not be awarded to support any project that in any way: violates law or City policy; violates a legal ownership interest, such as a copyright, of any party. Funds may not be spent for any purpose or message that includes, promotes, or fosters: profane, obscene, indecent, violent, or pornographic content and/or language; discrimination on the basis of race, creed, color, age,

religion, gender, sexual orientation, or national origin; defamatory or personal attacks; threats to any person or organization; information that may compromise public safety; or any purpose or message that the City deems to be inappropriate or not in the best interest of the City of Meridian. Additional limitations may apply.



2021-2022 Neighborhood Grant Program Application Form

Applicant Information

Applicant name _____

Organization (if applicable) _____

Applicant's parent name (if Applicant is under 18) _____

Phone number _____ E-mail address _____

Mailing Address _____

Project Information

Project Name _____

Project Type (check one)

Amenity (e.g., neighborhood garden, bike rack, bike repair station, dog waste bag station)

Beautification (e.g. signage, banners, trees, landscaping, art)

Clean up (e.g. graffiti removal, overgrown vegetation removal, litter removal)

Other: _____

Project Address/Location _____

Property owner _____

Acknowledgments

I, _____, hereby acknowledge the following stipulations and agree that if this proposal is selected for funding under the Neighborhood Grant Program, such funding shall occur subject to these general terms and conditions, as well as subject to other specific terms and conditions that shall be set forth in a separate, written grant recipient agreement between myself and the City of Meridian. I specifically acknowledge that:

INITIAL Before my Project is funded, I (or my parent/guardian) will be required to enter into a written agreement with the City establishing the specific terms and conditions of the grant funds provided.

INITIAL If this Project is selected for funding, neither the City of Meridian nor its officers or employees will assume liability for any loss or damage. This Project may involve risks, some of which are unknown.

INITIAL The procurement of any necessary insurance will be my sole responsibility. The City will not provide insurance or other coverage of any kind for loss, theft, or damage that I or anyone associated with the Project may or does incur.

INITIAL The City has made no offer or commitment to issue Neighborhood Grant funds; the City shall have no obligation to do so except by, and pursuant to, written agreement.

I acknowledge, understand, and agree to these general terms and conditions.

Signature: _____ Print name: _____

Parent Signature (If Applicant is Under 18): _____

Date: _____

EXHIBIT B

Project Budget | Beep, Beep, Jeep!

In-Kind Donations

- Anita Burgess - Research and Development
- Elizabeth Burgess - Research and Development
- Kevin Falk - Initial Design and layout of Jeep
- Summer Cook – Copy Writing

Budget

The total budget for the Beep, Beep, Jeep! interactive and inclusive feature to be added to the Bear Creek Park playground renovation is \$33,796.80. The Neighborhood Grant would help fulfill this portion of the project so we could focus additional fundraising and funding efforts on including more adaptive and inclusive equipment like those pictured in the Project Plan.

Estimate



PROJECT	BEAR CREEK PARK-MERIDIAN	DRAWING	N/A	ESTIMATE	21000-1
BILL TO	CITY OF MERIDIAN	SHIP TO	STEVE SIDOWAY	OPTION	1
	33 E. BROADWAY AVE.		2400 S. STODDARD RD.	DATE	5/12/2022
	MERIDIAN, ID 83642		MERIDIAN, ID 83642	EXPIRES	7/11/2022
	SSIDDOWAY@MERIDIANCITY.O		SSIDDOWAY@MERIDIANCITY.O		

ITEM	DESCRIPTION	QTY	AMOUNT
1003 FREESTANDING PLAY	GFRP: JEEP W/ WHEELCHAIR ACCESS, 118X92X52	1.00	\$ 25,102.80
4001 PARTS	ADDING LICENSE PLATE TNT AND BEEP BEEP	1.00	\$ 1,260.00
6003 INSTALLATION	INSTALLATION OF JEEP	1.00	\$ 880.00
6007 CONCRETE	42 LF CURBING FOR AREA BUMP OUT	42.00	\$ 2,310.00
6009 SITE PREPARATION	BASE ROCK AND SITE PREP FOR AREA BUMP OUT	1.00	\$ 770.00
2002 BONDED RUBBER MULCH	EXTRA BONDED RUBBER MULCH FOR BUMP OUT	1.00	\$ 3,654.00

\$ -
\$ -
\$ -
\$ -
\$ -
\$ -
\$ -
\$ -
\$ -
\$ -
\$ -
\$ -
\$ -
\$ -
\$ -

Thank You

Thank you for choosing Garrett Parks and Play for your recreation equipment needs. We sincerely appreciate your business!

SUBTOTAL	\$ 33,976.80
SALES TAX	\$ -
OFFLOAD	\$ -
TOTAL	\$ 33,976.80

Correspondence | Support of Land Owner

From: Steve Siddoway <ssiddoway@meridiancity.org>
Sent: Monday, April 18, 2022 8:37 AM
To: Anita Burgess <nitagem@msn.com>; Bruce Freckleton <bfreckleton@meridiancity.org>; Mike Barton <mbarton@meridiancity.org>; Kimberly Warren <kwarren@meridiancity.org>; Elizabeth@hiddengemmeridian.com <elizabeth@hiddengemmeridian.com>
Subject: RE: Anita Burgess - Tim Burgess All Inclusive Park Project - Beep! Beep!

Hi Anita!

I just got your message today. Thank you to Mike, who pointed out that it had been intercepted by our email filters. I understand that you and Mike connected on Friday and that he will focus on this when he returns from vacation. We look forward to working with you!

I have "green-listed" you email address, so your future emails should come through. If you have any questions while Mike is away this week, just let me know.

Thanks and have a wonderful week!

Steve

Steve Siddoway, CPRP | Parks & Recreation Director
City of Meridian | Parks and Recreation
33 E. Broadway Ave., Meridian, Idaho 83642
Phone: 208.888.3579 | Fax: 208.898.5501

Meridian Parks and Recreation: Quality. Community. Fun.

All e-mail messages sent to or received by City of Meridian e-mail accounts are subject to the Idaho law, in regards to both release and retention, and may be released upon request, unless exempt from disclosure by law.

From: Anita Burgess <nitagem@msn.com>
Sent: Tuesday, April 12, 2022 8:49 AM
To: Bruce Freckleton <bfreckleton@meridiancity.org>; Mike Barton <mbarton@meridiancity.org>; Steve

Siddoway <ssiddoway@meridiancity.org>; Kimberly Warren <kwarren@meridiancity.org>; Anita Burgess <nitagem@msn.com>; Elizabeth@hiddengemmeridian.com
Subject: Fw: Anita Burgess - Tim Burgess All Inclusive Park Project - Beep! Beep!

External Sender - Please use caution with links or attachments.

Good Morning, Bruce, Mike, Steve, Kim and Elizabeth,

I want to follow up with each of you and let you know how much Elizabeth and myself enjoyed our meeting concerning the ideas of our BEEP BEEP JEEP project.

I have visited the parks that were suggested. I feel that either park would be ok. Although, in viewing BEAR CREEK park I would love, to see this park move forward for our project.

The grand scheme of things this is truly a great area and very sentimental. Tim's Grand Parents Thruman and Doris Scott, owned the majority of this property with our Dairy farm, they allocated a park to be built. Later years, his Uncle and Aunt Theron and Sharon Scott, continued the farming. As well as the George Boyack Family who are dear friends of ours also owned some of the property. I have spoken to each of the families, the Scotts, Boyack's, and the Molenaar's they, are on board as well to help and give support. One of our young cousins on the Scott side is Handicapped as well as Tim, his Mom and Uncle Theron who were wheel chair bound with stokes and Als. Tim helped so many in his career, not only working as a boy on the farm but as he became a Civil Engineer, he helped so many in the community. He designed many a Handicapped Ramps and adaptive equipment to help.

Yesterday I visited with a few people using the park. Just to get a few opinions if they felt an "All Inclusive Park" option would be good. Wow! Did I get a response, they were on board- Ha ha the whole team! Here are a few of the needs they are seeing right now.

They were concerned about the bark under the playground equipment is a deep mess and the fading existing equipment needs to be replaced.

In visiting, I also spoke to a Coach of a small child soccer team. The Coach was thrilled about the idea of an interactive, JEEP, and an interactive pathway where the wheel chairs could move through the park and have things to do along the way. I also expressed our thoughts of the other

spongy material for under the play equipment. He said YES!! It's horrible just for a child with out handicaps.

My heart is telling me I think Bear Creek is perfect for our mountain theme as well. Smile... and for those who knew Tim we did call him Pappa Bear, but he was actually a Teddy Bear. Strangely enough, we spent many a summer camping at Bear Run in Idaho City.

Ok so ***I am ready to move forward***. Tim's Celebration of Life is May 21 and 22. I would like to share with all our friends. If I get a go ahead??

I would also like to start the process of the **Neighborhood Grant** because our deadlines are fast approaching- application Due: **May 13, 2022**. Strange enough it says project needs to be completed by September **9th**. WOW! Honk the Horn! That's Tim's Birthday!

Below, I included my first message to Bruce, so everyone is on the same page with my thoughts. Very sorry this is so long. But want to know we are truly excited to get this done.

1. Please, Let me know the next steps you would like me to take.
2. Please send me the information on the company with playground equipment as discussed. But if we can get specks on rules, we might have RUBICON build or a local person in the Treasure Valley.
3. Please send me any other grants we can apply for.
4. **Please reply** to me so I know each of you received my letter.

Thank you!
Always, Anita Burgess

Phone 208-890-0424
1905 W. Merganser
Meridian, Idaho 83642

From: Anita Burgess
Sent: Friday, March 25, 2022 6:55 AM
To: Anita's Jewelers Anita Burgess.

<nitagem@msn.com>; Bfreckleton@meridiancity.org <Bfreckleton@meridiancity.org>
Subject: Anita Burgess - Tim Burgess All Inclusive Park Project - Beep! Beep!

Dear Bruce,

Thank you for taking the time yesterday to discuss our families' thoughts on a "All Inclusive Park Project". We would very much appreciate to take this to further discussion and make sure we are on the calendar. So very exciting! I should be able, to be available most afternoons. It's at the top of my priority list for sure. I will be out of town April 27-May4th

I am sending over a few ideas and facts, to give you some incite to what was going on with Tim.

Thank you, Always Anita Burgess

PS, My Grandson calls Grandpas Yellow Jeep - BEEP! BEEP! - BEEP! BEEP! Park? How cute is that!

CONTACT INFO:

Anita Burgess

Phone: 208-890-0424, Email: Nitagem@msn.com

Anita's Jewelers -Meridian, 208-383-4866

Elizabeth Burgess

Phone: 208-863-0187

The Tolleth House - Hidden Gem Events - 134 E State Ave, Meridian

#1 Concern: My daughter Elizabeth brought to my attention last night there is a Neighborhood Grant program that has a deadline of May 13th. Should I try to apply for this? Because that could really help us <https://meridiancity.org/mayor/neighborhoodgrant>

#2 Tims past projects: I thought you would enjoy looking at a few of the projects Tim worked on over the years. Although in looking at this list, I know he did many more. Kinda crazy. He was a very strong, kind, but humble man. But he sure always took care of people! Please see attachment.

#3. Photos of a park where our Grandson visited. Attached. Our idea of the jeep's would be so you could actually drive a wheel chair into the space. But this gives a fun visual.

I also seen a raised sandbox that is neat, where a wheel chair can pull into it. Great full body swings and a path way for trikes! Brain Storming... sorry Squirrel...

My concern, many times installers, get things too high for special needs to reach, so that will be a top priority. Sometime they place a swing so high; you have to always lift the person into the seat.

Lifting a Special needs person or transporting them, just to the area to play, is one of the most difficult challenges for all. I get, while taking care of my Mother-in-Law for 10 years with a stroke, then Tim with ALS for 19 months. But were totally paralyzed.

#4. We have **"Tim's Celebration of life" May 21 and 22.** We have many friends attending. Please place it on your calendar. Your invite will be coming.

Once we know we can move forward, we will start asking for donations for a park, in lu of flowers.

Many friends and family are on standby willing to help. Some of my dearest friends, Ann Marie Molenaar and Sister Susie just finished their park. My other friend Becky Kawano did the Densho Garden in Caldwell. My Sister and Brother-in-law Marlyn & Gary Ruschman Sand and gravel, have worked on the Botanical Gardens for years. Tims, Aunt Sharon Scott also just sold some of Tims Granddads property for development and they had done a park at Bear Creek and a new one in the property they just sold.

As I mentioned my girls were the sister troop (younger girls) and raised money for our Girl Scout troop in Downtown Meridian - "Generations Plaza". Myself I worked for the World Special Olympics for three years. Talk about raise money! ...lol

Please rest assured, we are not afraid to step into the ring, and have nothing but good intentions for a needed project to complete a lasting legacy. Keeping my fingers crossed.

Please confirm you received my email. Thank you Anita

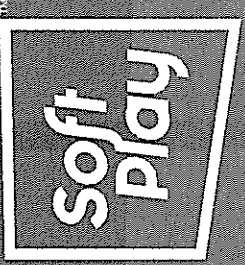

Jeep Concept Images



Jeep Concept

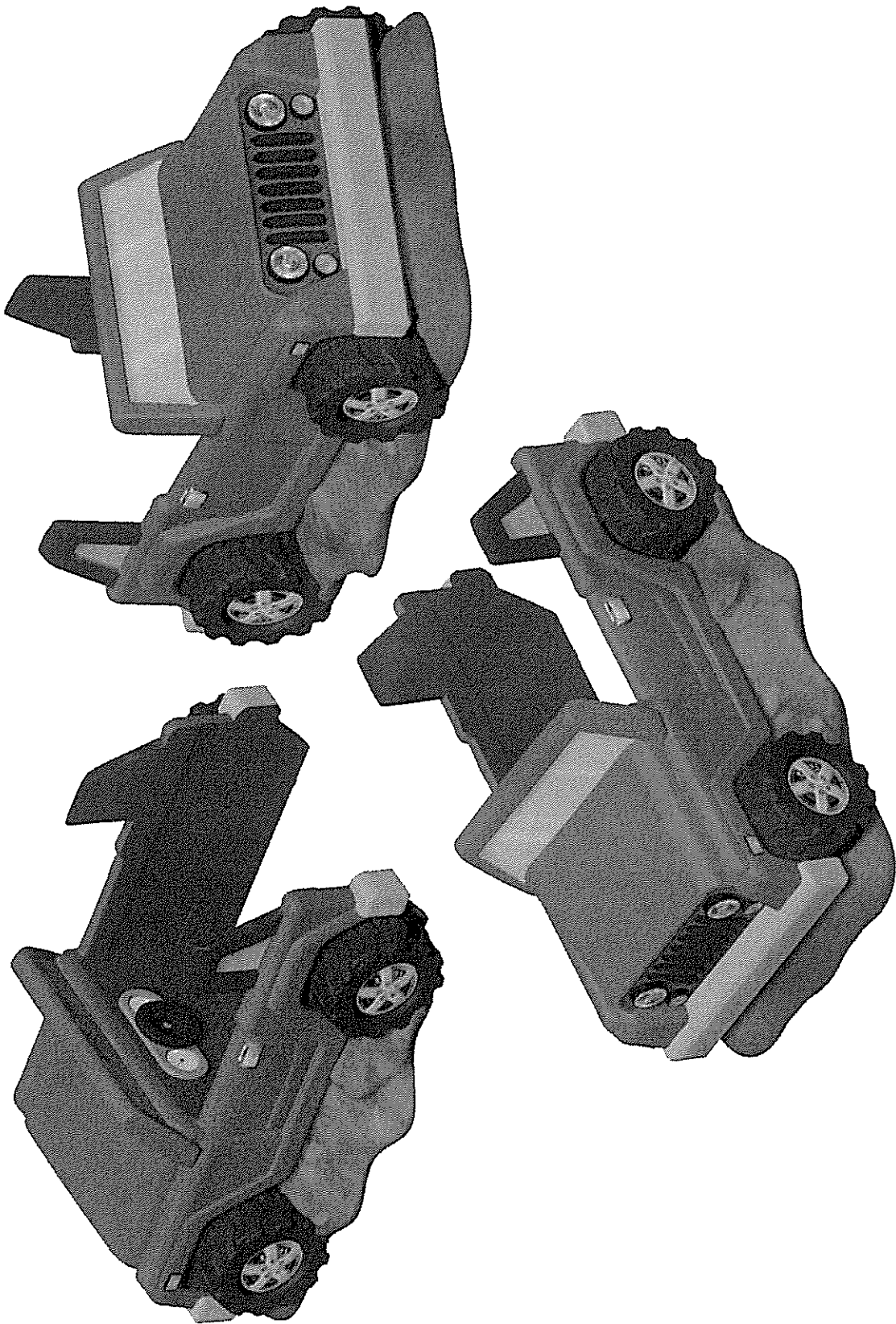

SOFTPLAY | DESIGN PACKAGE & PROPOSAL FOR:
Jeep Concepts

DESIGNS ARE THE PROPERTY OF SOFT PLAY LLC AND ARE NOT TO BE SOLD, DISTRIBUTED, OR MANUFACTURED WITHOUT EXPRESS WRITTEN CONSENT. PRICES, COLORS, AND DESIGNS ARE SUBJECT TO CHANGE AT THE DISCRETION OF SOFT PLAY, LLC.



303.662.0302 | softplay.com

Jeep Concept 10' x 8' x 4'-4"

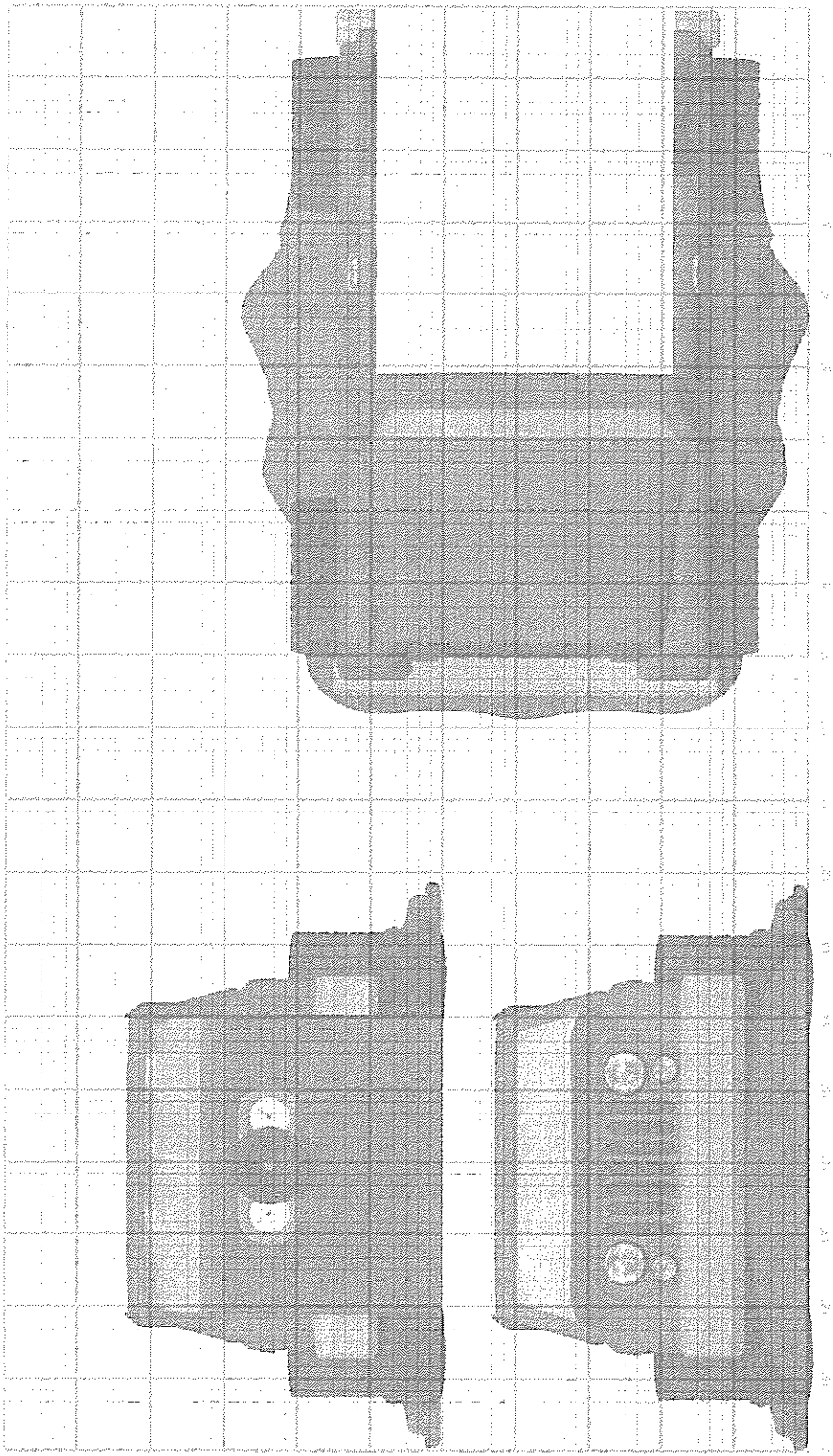

SOFTPLAY | DESIGN PACKAGE & PROPOSAL FOR:
Jeep Concepts



DESIGNS ARE THE PROPERTY OF SOFT PLAY, LLC AND ARE NOT TO BE SOLD, DISTRIBUTED, OR MANUFACTURED WITHOUT EXPRESS WRITTEN CONSENT. PRICES, COLORS, AND DESIGNS ARE SUBJECT TO CHANGE AT THE DISCRETION OF SOFT PLAY, LLC.

303.662.0302 | softplay.com

THANK YOU

We appreciate your time in reviewing our proposal.

Softplay, Inc.

10000 E. 1st Ave.

Denver, CO 80231

Phone: 303.662.0302 | Email: info@softplay.com

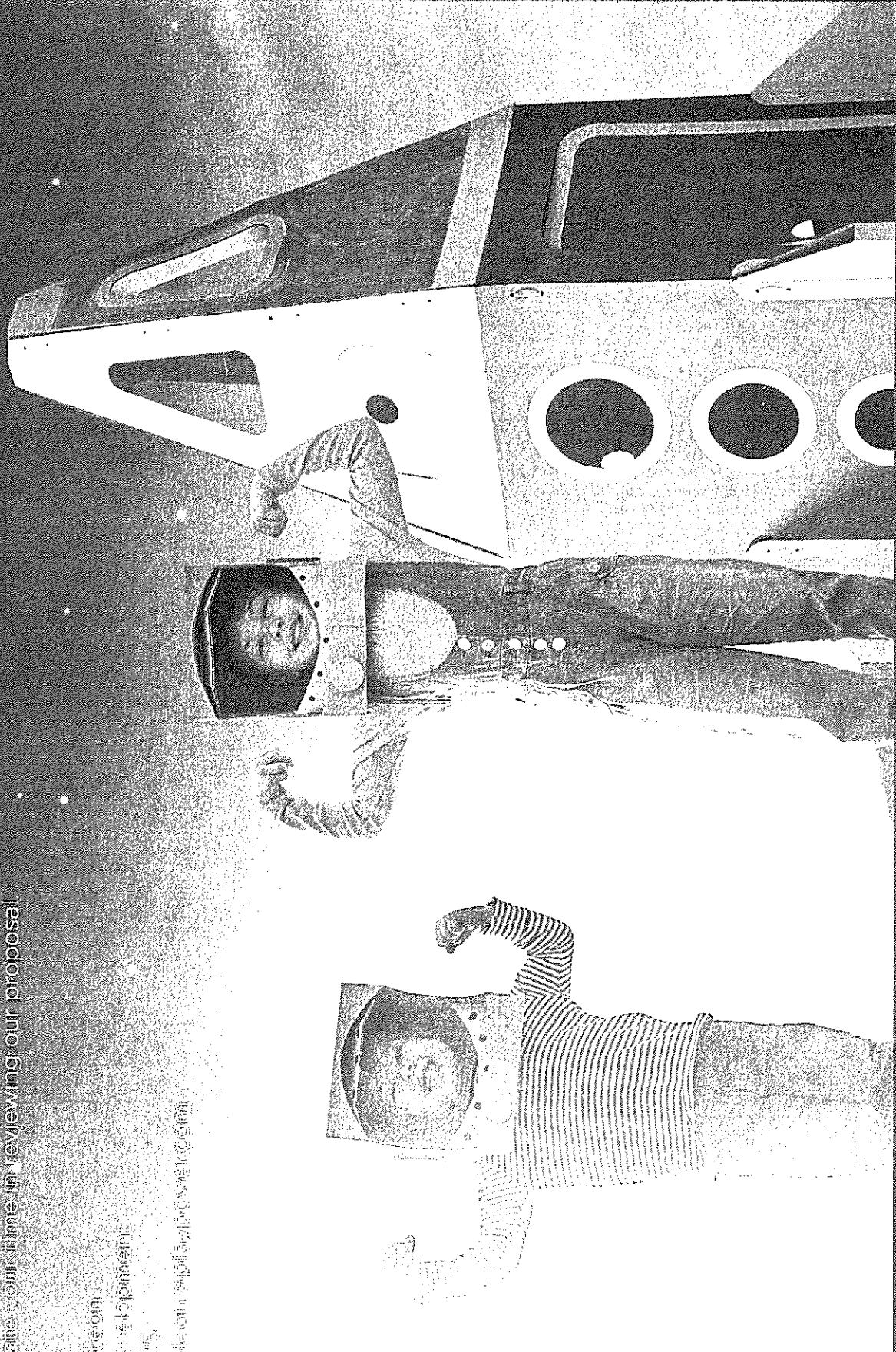

SOFTPLAY | DESIGN PACKAGE & PROPOSAL FOR:
XXX



303.662.0302 | softplay.com

DESIGNS ARE THE PROPERTY OF SOFTPLAY, LLC AND ARE NOT TO BE SOLD, DISTRIBUTED OR MANUFACTURED WITHOUT EXPRESS WRITTEN CONSENT. PRICES, COLORS AND DESIGNS ARE SUBJECT TO CHANGE AT THE DISCRETION OF SOFTPLAY, LLC.

Project Plan | Beep, Beep, Jeep!

Timeline

June 2022: Order interactive and inclusive Jeep equipment from Garrett Parks and Play

June and July 2022: Assist and coordinate volunteer efforts to support Meridian Parks and Recreation Department of the Bear Creek Park Playground renovation.

August 2022: Work with Garrett Parks and Play, and Meridian Parks and Recreation Department to install the Beep, Beep, Jeep! and surrounding area as described and noted on budget estimate.

September 9, 2022: Celebration and Opening Day of the Beep, Beep, Jeep! on the anniversary of Tim's birthday and on the completion date of the Neighborhood Grant Project.

Top view of Jeep

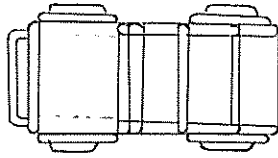

Front view of Jeep

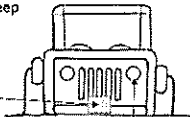

We will have special flat plate with Tim's information on the plate

Cut outs for grill and lights

Fenders would be also be bent welded tubing

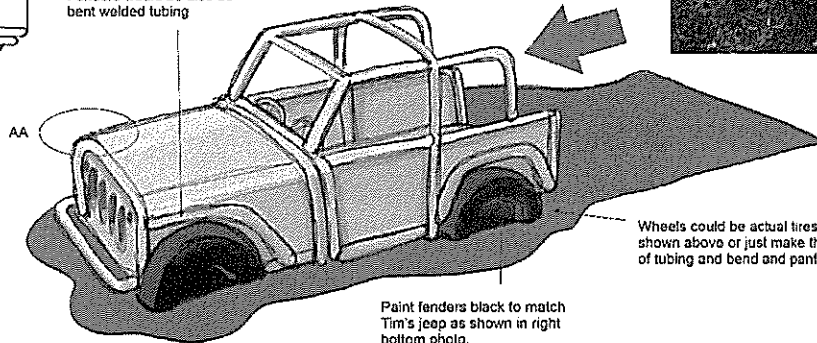

Wheelchair access from the rear of the jeep on the flat ground

Paint fenders black to match Tim's jeep as shown in right bottom photo.

Wheels could be actual tires cut in half like the ones shown above or just make them out of larger dia. of tubing and bend and pant black.

Build something like this piece of playground equipment. Use larger metal tubing and finish frame with bent flat pieces of sheet metal as shown below.

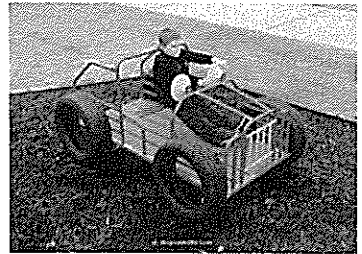

KFalk Design
Kevin Falk
208 998-2012
kfalkdesign.com

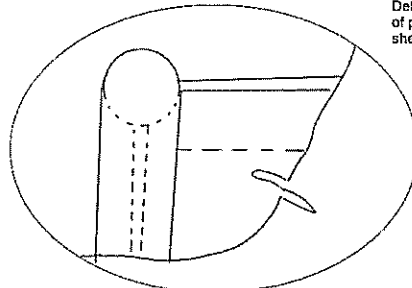

Detail AA showing a top view of pipe and welding of the larger sheets for jeep shape.

Paint ground darker brown so that it looks like its been driving through mud and is sunk halfway up the wells and to make the back part flush so that wheelchairs can roll in from the back.



Bear Creek Park Option 2 Meridian, ID

2-12

5-12

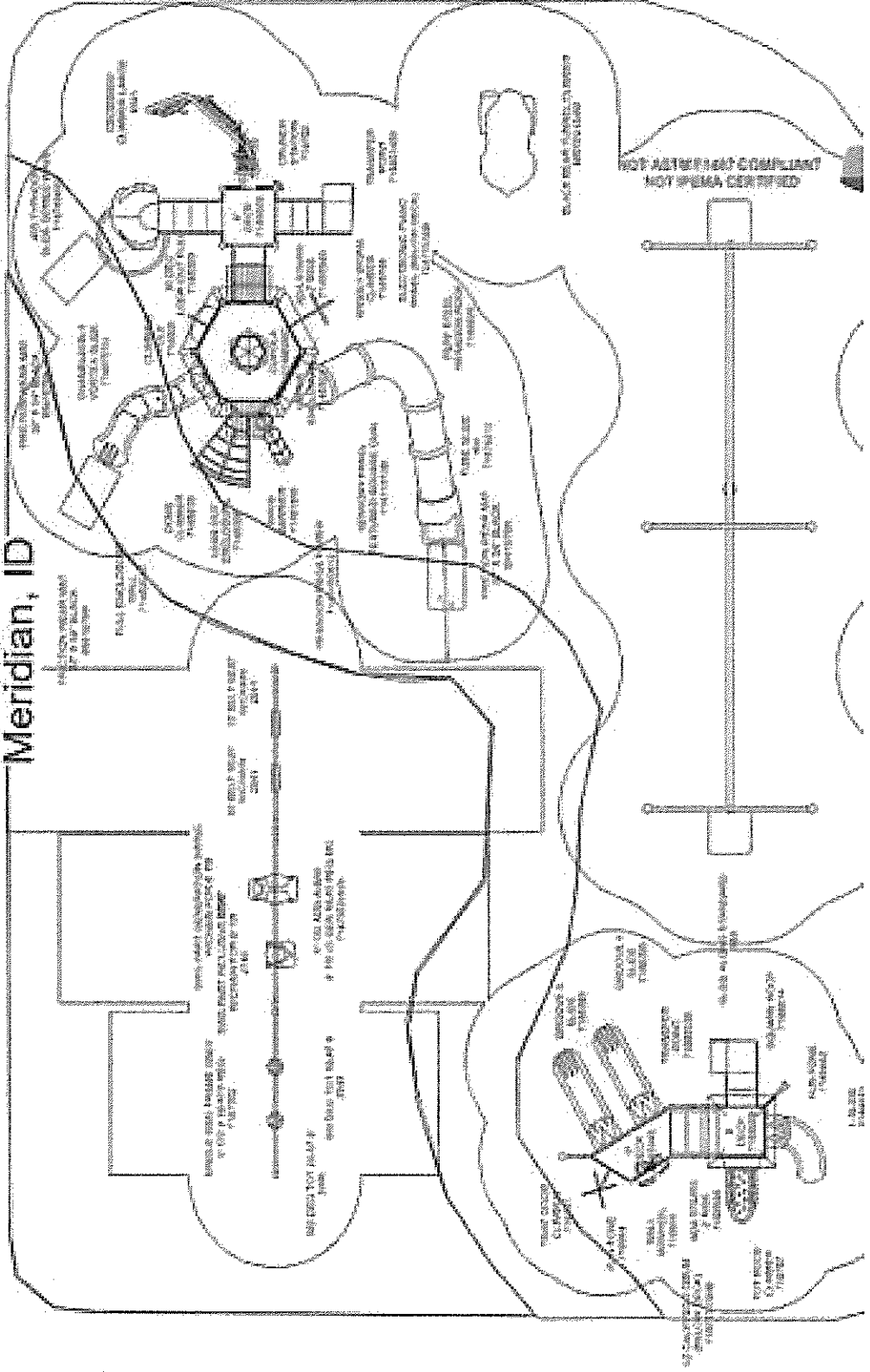

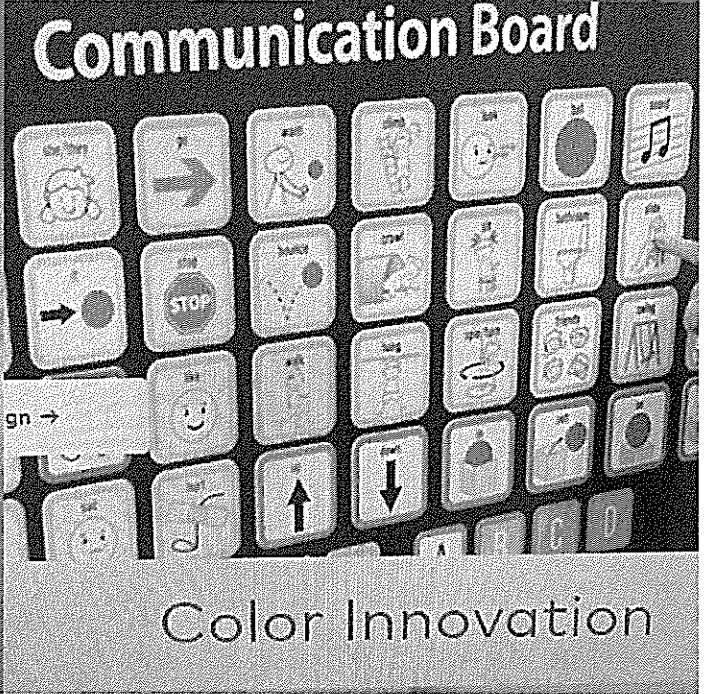
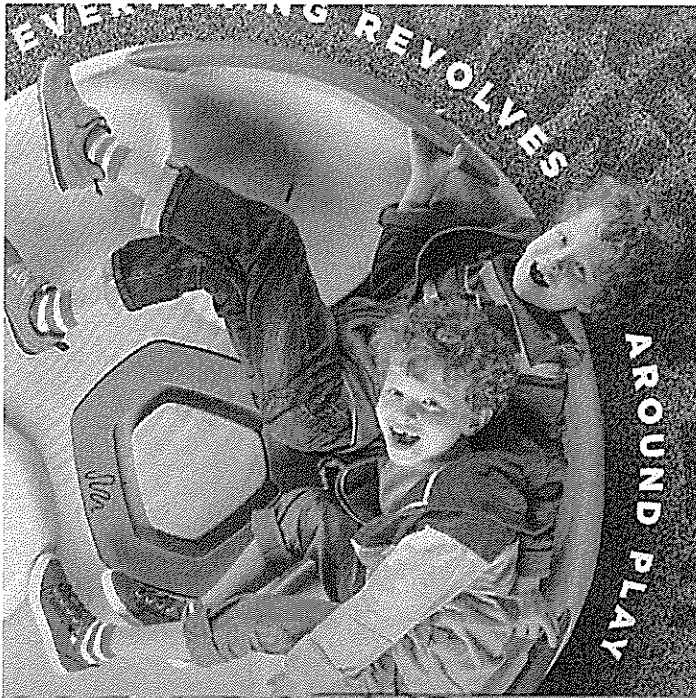

Adaptive Play Equipment



Obstacle Course and Pathway



Interactive Wildlife Features

Exhibit C

Estimate



PROJECT	BEAR CREEK PARK-MERIDIAN	DRAWING	N/A	ESTIMATE	21000-1
BILL TO	CITY OF MERIDIAN	SHIP TO	STEVE SIDDOWAY	OPTION	1
	33 E. BROADWAY AVE.		2400 S. STODDARD RD.	DATE	7/5/2022
	MERIDIAN, ID 83642		MERIDIAN, ID 83642	EXPIRES	9/3/2022
	SSIDDOWAY@MERIDIANCITY.O		SSIDDOWAY@MERIDIANCITY.O		

ITEM	DESCRIPTION	QTY	AMOUNT
1003 FREESTANDING PLAY	GFRP: JEEP W/ WHEELCHAIR ACCESS, 118X92X52	1.00	\$ 25,102.80
4001 PARTS	ADDING LICENSE PLATE TNT AND BEEP BEEP	1.00	\$ 1,260.00
6003 INSTALLATION	INSTALLATION OF JEEP	1.00	\$ 880.00
6007 CONCRETE	56 LF CURBING FOR AREA BUMP OUT (8"X8" CURB WITH REBAR FOR REINFORCEMENTS)	56.00	\$ 3,080.00
6009 SITE PREPARATION	BASE ROCK AND SITE PREP FOR AREA BUMP OUT	1.00	\$ 770.00
2002 BONDED RUBBER MULCH	374 SF EXTRA BONDED RUBBER MULCH FOR BUMP OUT	374.00	\$ 6,850.76
6009 SITE PREPARATION	SAW CUT AND REMOVE 22' SECTION OF CONCRETE	1.00	\$ 550.00
	PERFORMANCE BOND	1.00	\$ 4,703.00
			\$ -
			\$ -
			\$ -
			\$ -
			\$ -
			\$ -
			\$ -
			\$ -
			\$ -
			\$ -

Thank You

Thank you for choosing Garrett Parks and Play for your recreation equipment needs. We sincerely appreciate your business!

SUBTOTAL	\$ 43,196.56
SALES TAX	\$ -
OFFLOAD	\$ -
TOTAL	\$ 43,196.56

Questions about your Estimate? Contact us!

P.O. Box 57246, Murray, UT 84157

1 (800) 748-4608 / (801) 265-8443

design@garrettplay.com

Notes

SALES TAX

Sales Tax (if applicable) is subject to change based on purchase location and order date. Final Sales Tax amount will be reflected on invoice(s).

FREIGHT

Freight costs are included in these prices.

PAYMENT / PERFORMANCE BOND

Payment and/or performance bond costs are not included in this estimate. If a payment and/or performance bond is required to complete this project, the cost will be added to this estimate or will result in a change order.