

# Exhibit A – Attachment 2

Discovery Bike Park

City of Meridian Parks and Recreation

Construction Drawings



















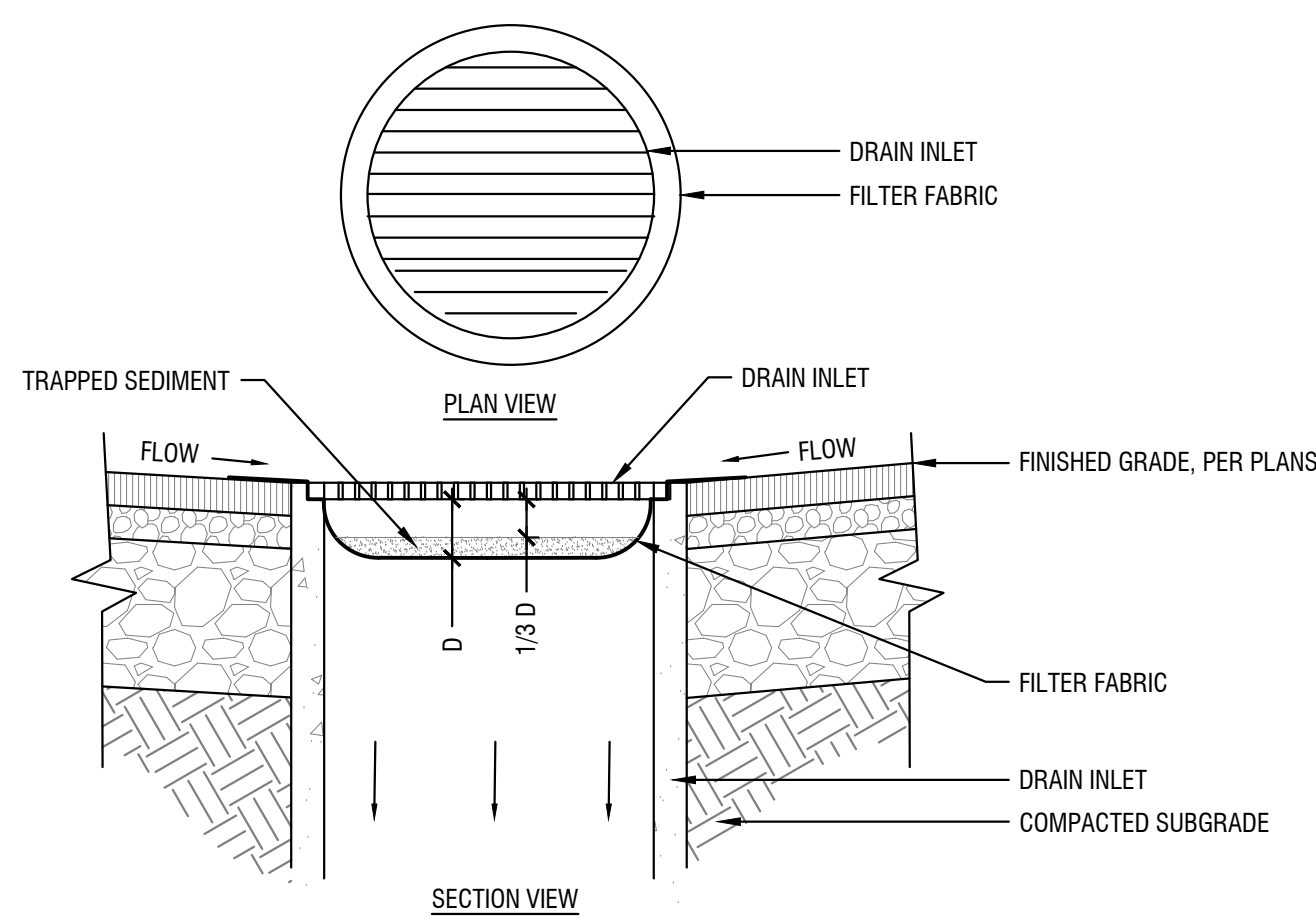

**NOTES:**

1. INSPECT PERIODICALLY AND REPAIR/REPLACE AS REQUIRED.
2. REMOVE SEDIMENT ACCUMULATIONS WHEN FILTER CAPACITY IS IMPAIRED BY 50%.
3. OTHER METHODS OF INLET PROTECTION MAY BE APPROVED UPON REVIEW BY THE PLAN PREPARER.
4. SEE STATE OF IDAHO CATALOG OF STORM WATER BEST MANAGEMENT PRACTICES BMP #13 AND BMP #74 FOR ADDITIONAL INFORMATION.

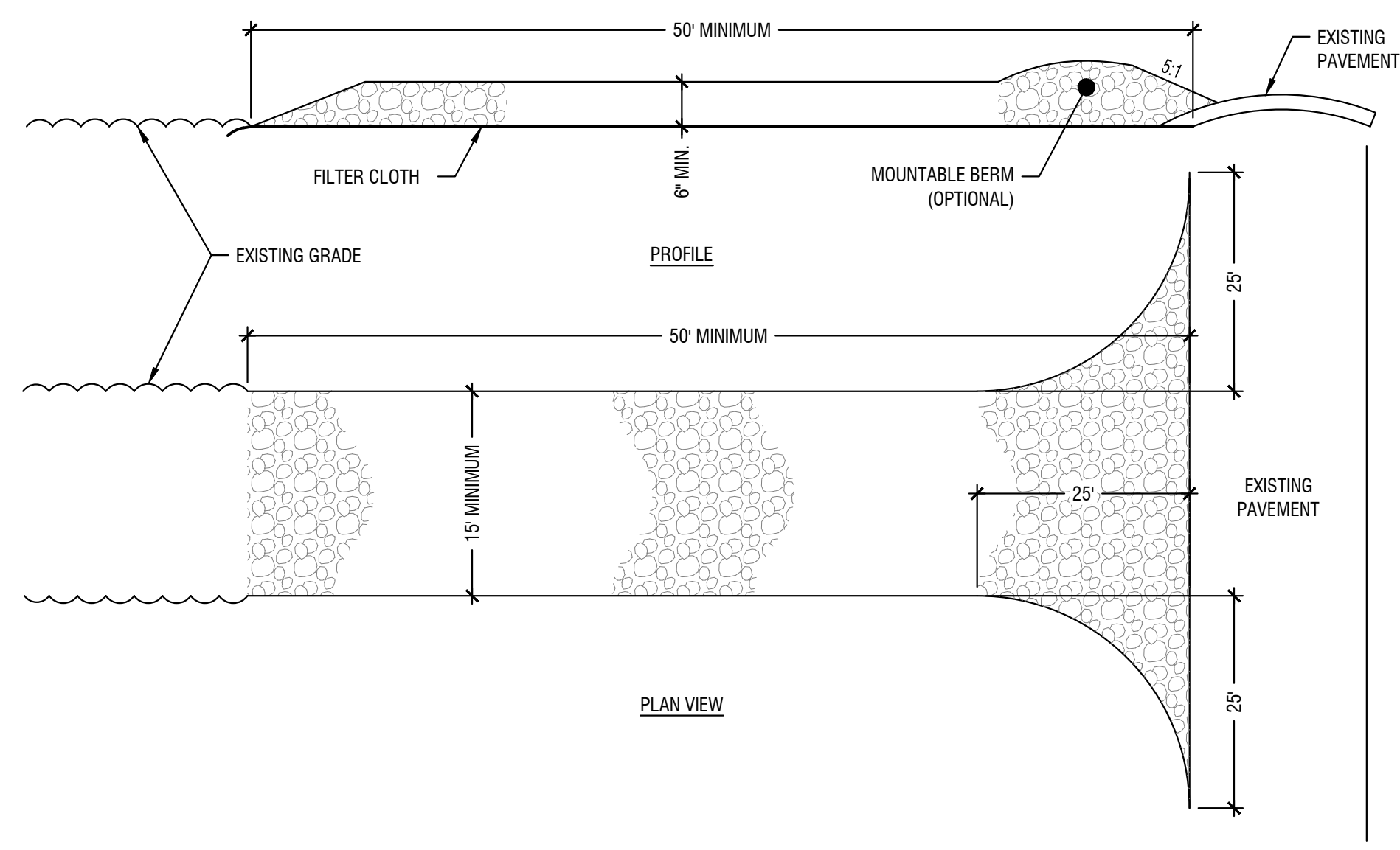

**CONSTRUCTION SPECIFICATIONS**

1. STONE SIZE-USE CRUSHED 2" STONE OR RECLAIMED OR RECYCLED CONCRETE EQUIVALENT FOR TOP LAYER, 2"-8" DIAMETER FOR BASE LAYER.
2. LENGTH-AS REQUIRED, BUT NOT LESS THAN 50 FEET EXCEPT ON A SINGLE RESIDENCE LOT WHERE A 30 FOOT MINIMUM LENGTH WOULD APPLY.
3. THICKNESS-NOT LESS THAN 6 INCHES.
4. WIDTH-10 FOOT MINIMUM, BUT NOT LESS THAN THE FULL WIDTH AT POINTS WHERE INGRESS OR EGRESS OCCURS.
5. FILTER CLOTH-WILL BE PLACED OVER THE ENTIRE AREA PRIOR TO PLACING OF STONE. FILTER WILL NOT BE REQUIRED ON A SINGLE FAMILY RESIDENCE LOT.
6. SURFACE WATER-ALL SURFACE WATER FLOWING OR DIVERTED TOWARD CONSTRUCTION ENTRANCES SHALL BE PIPED ACROSS THE ENTRANCE. IF PIPING IS IMPRACTICAL, A MOUNTABLE BERM WITH 5:1 SLOPES WILL BE PERMITTED.
7. MAINTENANCE-THE ENTRANCE SHALL BE MAINTAINED IN A CONDITION WHICH WILL PREVENT TRACKING OR FLOWING OF SEDIMENT ONTO PUBLIC RIGHT-OF-WAY. THIS MAY REQUIRE PERIODIC TOP DRESSING WITH ADDITIONAL STONE AS CONDITIONS DEMAND AND REPAIR AND/OR CLEANOUT OF ANY MEASURES USED TO TRAP SEDIMENT. ALL SEDIMENT SPILLED, DROPPED, WASHED OR TRACKED ONTO PUBLIC RIGHT-OF-WAY MUST BE REMOVED IMMEDIATELY.
8. WASHING-WHEELS SHALL BE CLEANED TO REMOVE SEDIMENT PRIOR TO ENTRANCE ONTO PUBLIC RIGHT-OF-WAY. WHEN WASHING IS REQUIRED, IT SHALL BE DONE ON AN AREA STABILIZED WITH STONE AND WHICH DRAINS INTO AN APPROVED SEDIMENT TRAPPING DEVICE.
9. PERIODIC INSPECTION AND NEEDED MAINTENANCE SHALL BE PROVIDED AFTER EACH RAIN.

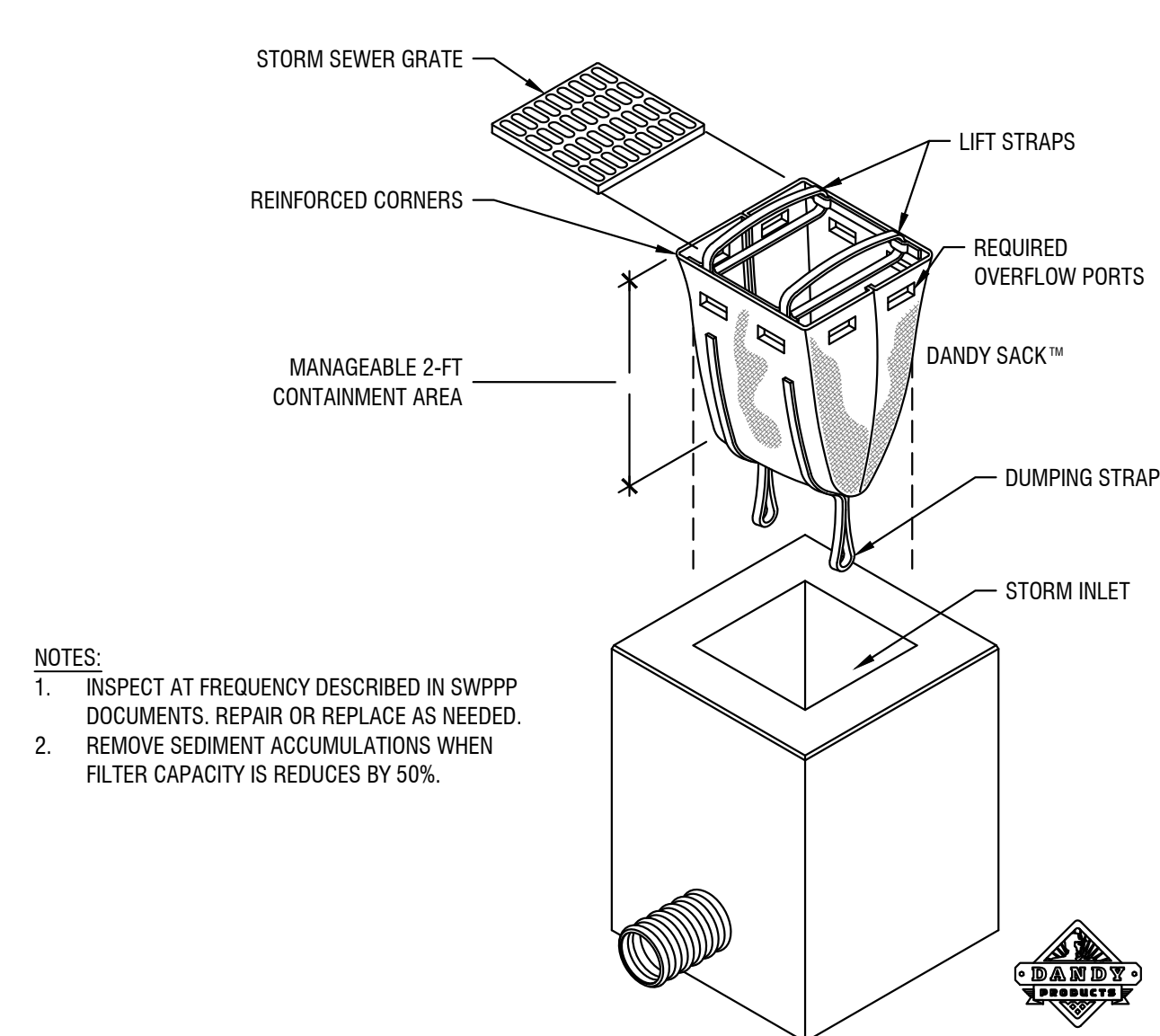

**DANDY SACK™ SPECIFICATIONS**

NOTE: THE DANDY SACK™ WILL BE MANUFACTURED IN THE U.S.A. FROM A WOVEN MONOFILAMENT FABRIC THAT MEETS OR EXCEEDS THE FOLLOWING SPECIFICATIONS:

REGULAR FLOW DANDY SACK™ (BLACK)			
MECHANICAL PROPERTIES	TEST METHOD	UNITS	MARV
GRAB TENSILE STRENGTH	ASTM D 4832	KN (LBS)	1.78 (400) X 1.40 (315)
GRAB TENSILE ELONGATION	ASTM D 4832	%	15 X 15
PUNCTURE STRENGTH	ASTM D 4833	KN (LBS)	0.67 (150)
MULLER BURST STRENGTH	ASTM D 3786	KPA (PSI)	9506 (800)
TRAPEZOID TEAR STRENGTH	ASTM D 4533	KN (LBS)	0.87 (195) X 0.23 (165)
UV RESISTANCE	ASTM D 4355	%	90
APPARENT OPENING SIZE	ASTM D 4751	MM (US STD SIEVE)	0.425 (40)
FLOW RATE PERMITTIVITY	ASTM D 4491	1/MIN/IN <sup>2</sup> (CM/IN <sup>2</sup> )	285 (70)
PERMITTIVITY	ASTM D 4491	SEC.	0.90

H-FLOW DANDY SACK™ (SAFETY ORANGE)			
MECHANICAL PROPERTIES	TEST METHOD	UNITS	MARV
GRAB TENSILE STRENGTH	ASTM D 4832	KN (LBS)	1.62 (365) X 0.89 (200)
GRAB TENSILE ELONGATION	ASTM D 4832	%	24 X 10
PUNCTURE STRENGTH	ASTM D 4833	KN (LBS)	0.49 (80)
MULLER BURST STRENGTH	ASTM D 3786	KPA (PSI)	3087 (450)
TRAPEZOID TEAR STRENGTH	ASTM D 4533	KN (LBS)	0.51 (115) X 0.33 (75)
UV RESISTANCE	ASTM D 4355	%	90
APPARENT OPENING SIZE	ASTM D 4751	MM (US STD SIEVE)	0.425 (40)
FLOW RATE PERMITTIVITY	ASTM D 4491	1/MIN/IN <sup>2</sup> (CM/IN <sup>2</sup> )	5907 (149)
PERMITTIVITY	ASTM D 4491	SEC.	2.1

\*Note: All Dandy Sacks™ can be ordered with our optional absorbent pillows

**1 Drop Inlet Protection Type III (BMP 13)**  
Scale: NTS

**2 Stabilized Construction Entrance (BMP 41)**  
Scale: NTS

**3 Drop Inlet Protection Type I (BMP 13)**  
Scale: NTS

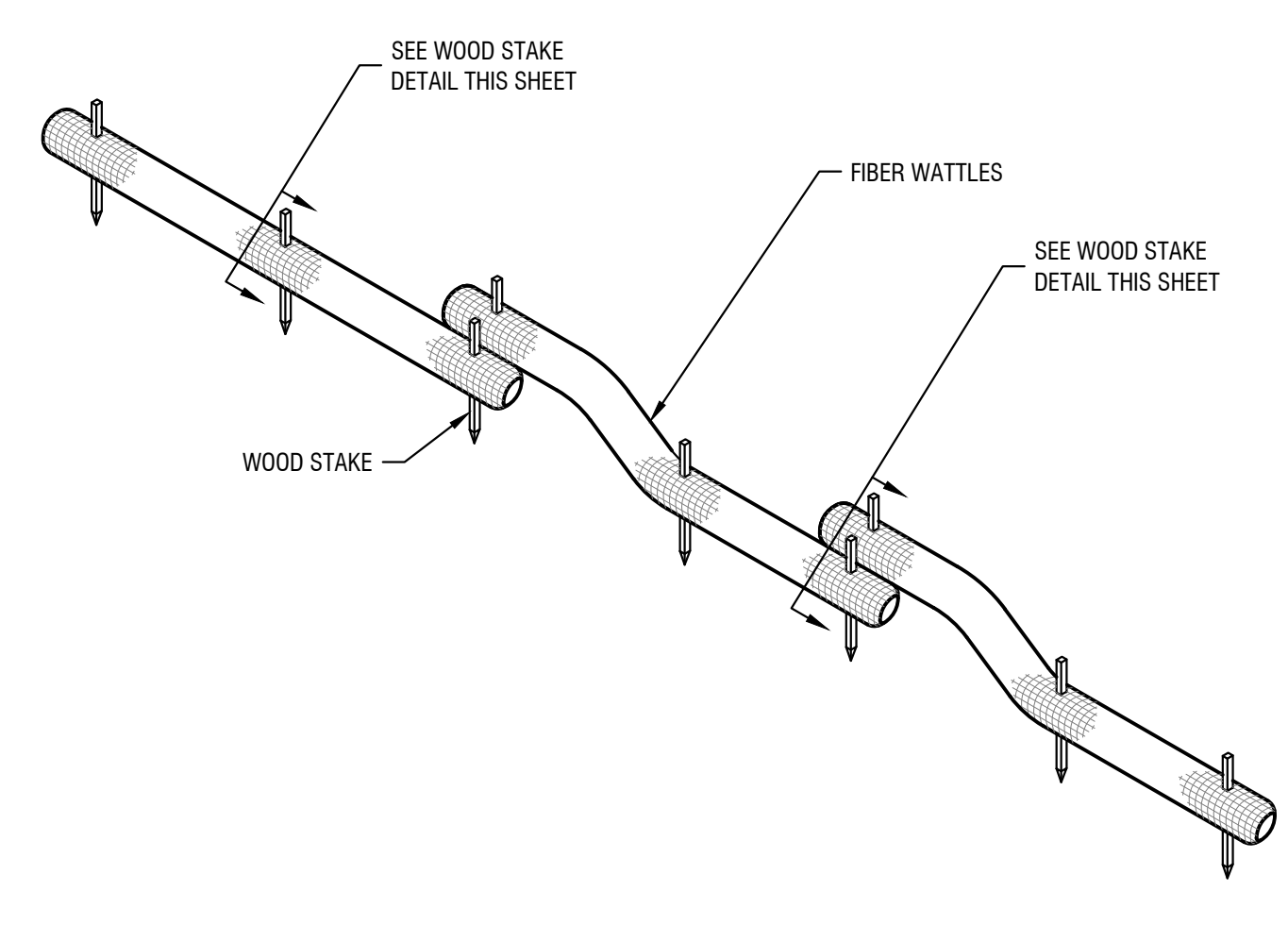

**4 Fiber Roll (BMP 35)**  
Scale: NTS

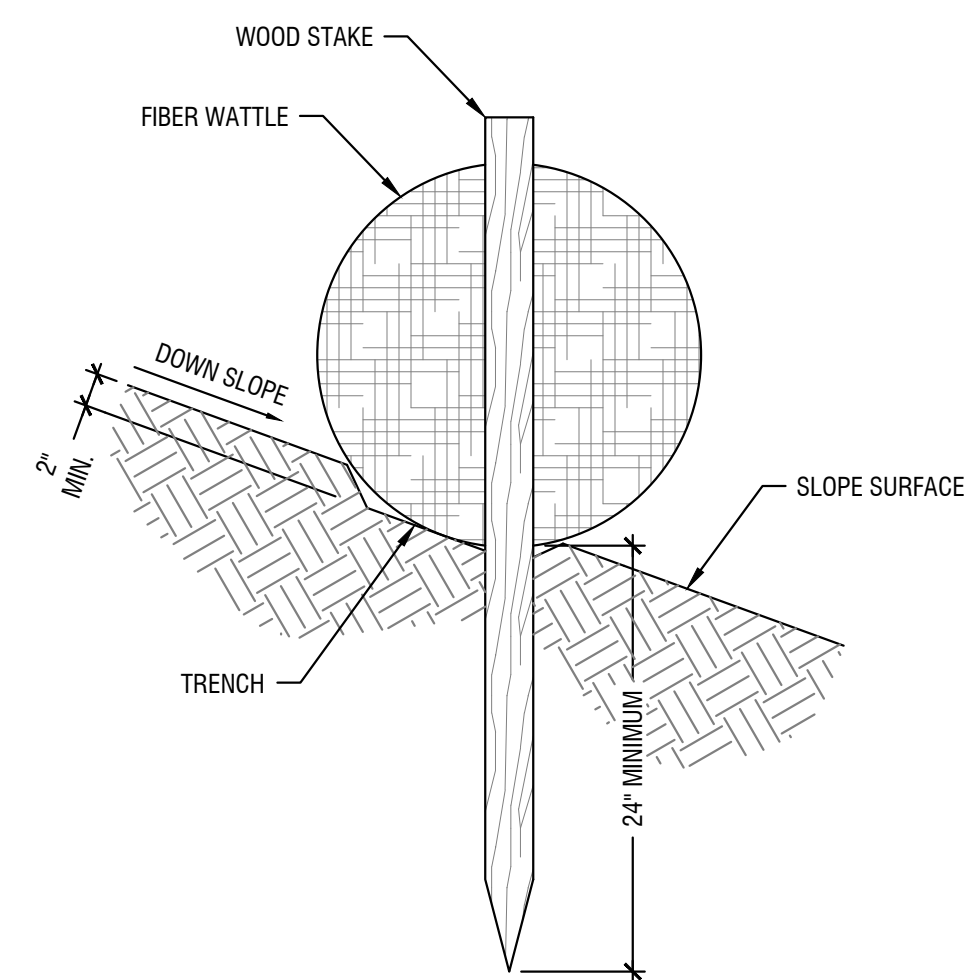

**5 Fiber Roll Stake Section (BMP 35)**  
Scale: NTS

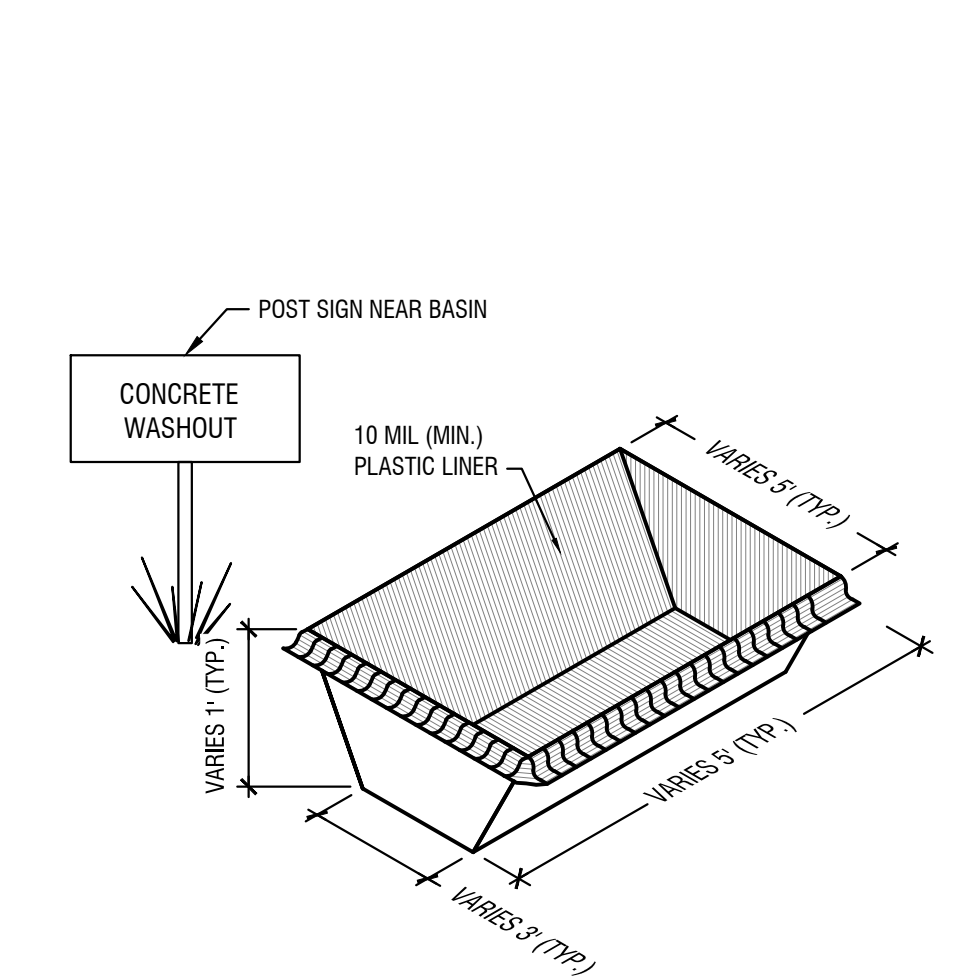

**6 Concrete Washout (BMP 49)**  
Scale: NTS

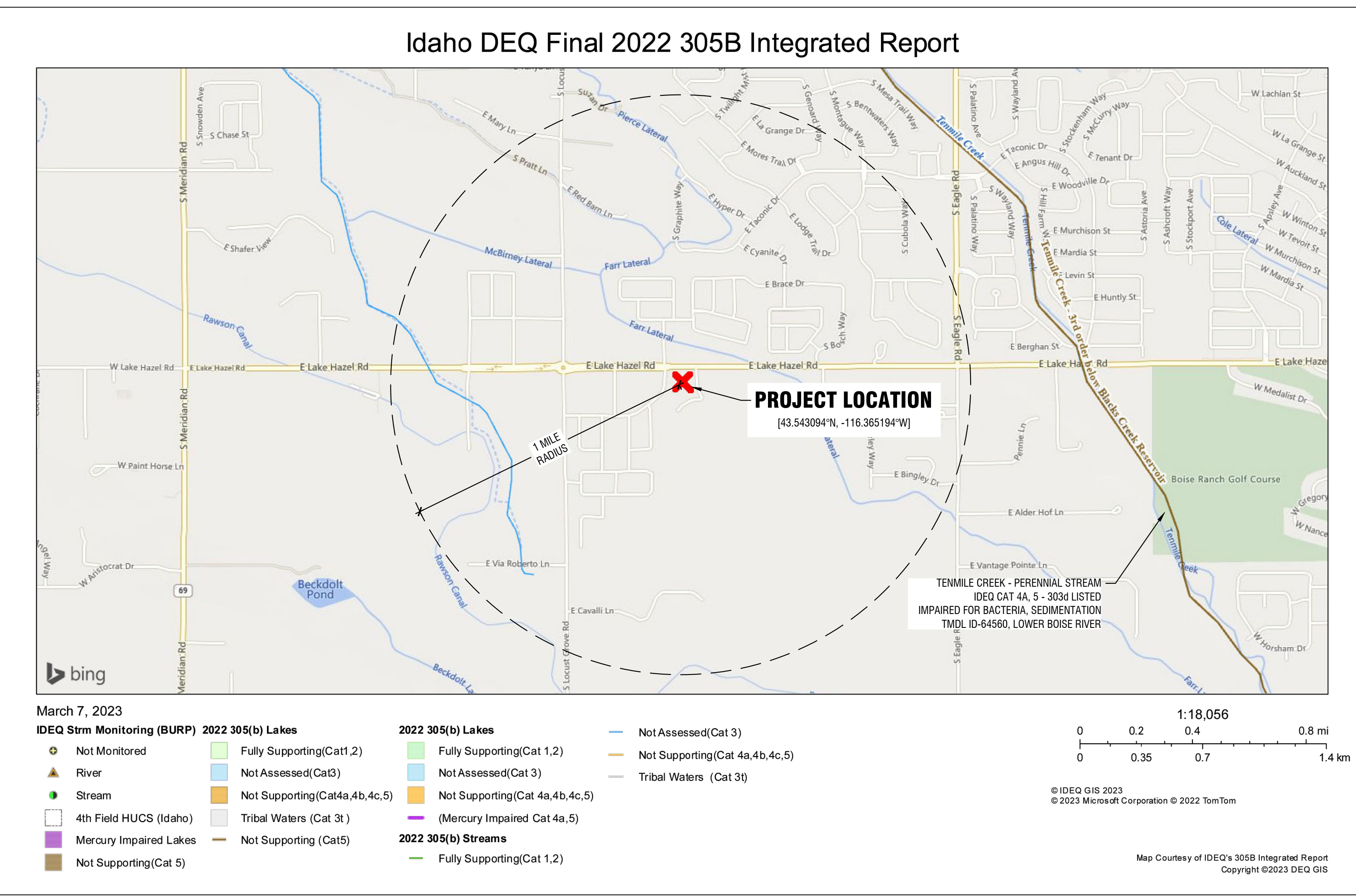

**Waters of the US Map**

Revisions

1.	









- Sheet Notes:**
- CONTRACTOR SHALL COMPLY WITH ALL NOTES, PLAN SHEET C0.00.
  - REFER CLOSELY TO SITE LAYOUT DRAWINGS IN RELATION TO SITE LAYOUT ITEMS. CONTRACTOR TO VERIFY LISTED DIMENSIONS PRIOR TO CONSTRUCTION.
  - THE CONTRACTOR SHALL VERIFY ALL DIMENSIONS DISTANCES AND GRADES IN THE FIELD AND BRING ANY DISCREPANCIES TO THE ATTENTION OF THE OWNER'S REPRESENTATIVE FOR A DECISION PRIOR TO COMMENCING WITH THE WORK.
  - COORDINATE INSTALLATION OF ELECTRICAL CONDUITS AND IRRIGATION SLEEVES WITH RESPECTIVE DRAWINGS AND CONTRACTORS, AS REQUIRED.
  - ALL WALKS AND FLATWORK SHALL BE ESTABLISHED IN THE FIELD FOR REVIEW AND APPROVAL. THE CONTRACTOR SHALL LAYOUT THE AREA OR FORM WORK FOR REVIEW BY THE OWNER'S REPRESENTATIVE. AFTER REVIEW AND NECESSARY MODIFICATIONS AS DIRECTED BY THE OWNER'S REPRESENTATIVE, THE CONTRACTOR SHALL PROCEED WITH CONSTRUCTION. IF APPROVAL IS NOT OBTAINED, THE CONTRACTOR IS RESPONSIBLE FOR REMOVAL OF ANY UNAUTHORIZED FIELD ADJUSTMENTS.
  - TRANSITION OF CURVES TO OTHER CURVES AND CURVES TO TANGENTS SHALL BE SMOOTH AND CONTINUOUS.
  - CONTRACTOR SHALL COMPLY WITH ADA ACCESSIBILITY GUIDELINES WITHIN THE PUBLIC RIGHT-OF-WAY THROUGHOUT THE DURATION OF THE PROJECT AS REQUIRED BY THE AUTHORITY HAVING JURISDICTION.
  - LONGITUDINAL SLOPE OF ALL SIDEWALKS SHALL NOT EXCEED 5.00%. CROSS SLOPES OF ALL SIDEWALKS SHALL NOT EXCEED 2.00%. SLOPES WITHIN PEDESTRIAN RAMPS AND WINGS SHALL NOT EXCEED 1:12 SLOPE. THERE ARE NO TOLERANCES ALLOWED ABOVE THE MAXIMUM SLOPES.

- Keynotes:**
- BIKE PARK ENTRY SIGN, FURNISHED AND INSTALLED BY CITY OF MERIDIAN.
  - TRAIL MAP SIGN, FURNISHED AND INSTALLED BY CITY OF MERIDIAN.
  - EXISTING TEMPORARY TURN-AROUND.
  - PUMP TRACK, DESIGN BY AMERICAN RAMP CO., REFER TO DETAIL 3/CZ.50, FOR REFERENCE ONLY.
    - PUMP TRACK ENTRY.
    - RETURN TRAIL.
    - FLOW TRAIL POINT OF ENTRY.
    - FLOW TRAIL PATHWAY AND FEATURES, REFER TO DETAILS ON SHEET C2.50, FOR REFERENCE ONLY.
      - BEGINNER / GREEN
      - INTERMEDIATE / BLUE
      - EXPERT / BLACK
    - BASEBALL FIELD LANDSCAPE BUFFER.
    - PEDESTRIAN RAMP AND CROSSWALK, BY OTHERS.
    - POTENTIAL STOCKPILING AREA.
    - DRAINAGE FACILITY, REFER TO SHEET C4.00.

**Material Legend**

	LANDSCAPE AREA PER L1.00 SERIES.		FLOW TRAIL PATH PER DETAIL 1/CZ.50.
	PUMP TRACK BY AMERICAN RAMP COMPANY.		STANDARD ASPHALT PAVEMENT PER DETAIL 4/CZ.50.
	2" TO 4" COBBLE ROCK AT 6" DEPTH, LOCALLY SOURCED.		

<b>7.1</b>	<b>BEGINNER GREEN FLOW TRAIL</b>
	<b>FEATURE/LANDING IDENTIFICATION</b>
	ROLLER DOUBLE JUMP
	LEFT BERM
<b>START TO FINISH</b>	RIGHT OFFSET ROLLER
	TABLE TOP JUMP
	RIGHT BERM
	TABLE TOP JUMP
	END BERM

<b>7.2</b>	<b>INTERMEDIATE BLUE FLOW TRAIL</b>
	<b>FEATURE/LANDING IDENTIFICATION</b>
	STEP DOWN JUMP
	DOUBLE JUMP
	ROLLER DOUBLE JUMP
<b>START TO FINISH</b>	RIGHT HIP DOUBLE JUMP
	DOUBLE JUMP WITH SPLIT LANDINGS
	DOUBLE JUMP
	STEP UP JUMP
	END BERM

<b>7.3</b>	<b>EXPERT BLACK FLOW TRAIL</b>
	<b>FEATURE/LANDING IDENTIFICATION</b>
<b>START TO FINISH</b>	RIGHT HIP DOUBLE JUMP
	STEP UP JUMP
	END BERM



**DISCOVERY BIKE PARK**  
 City of Meridian Parks & Recreation  
 2121 E LAKE HAZEL RD  
 MERIDIAN, ID 83642

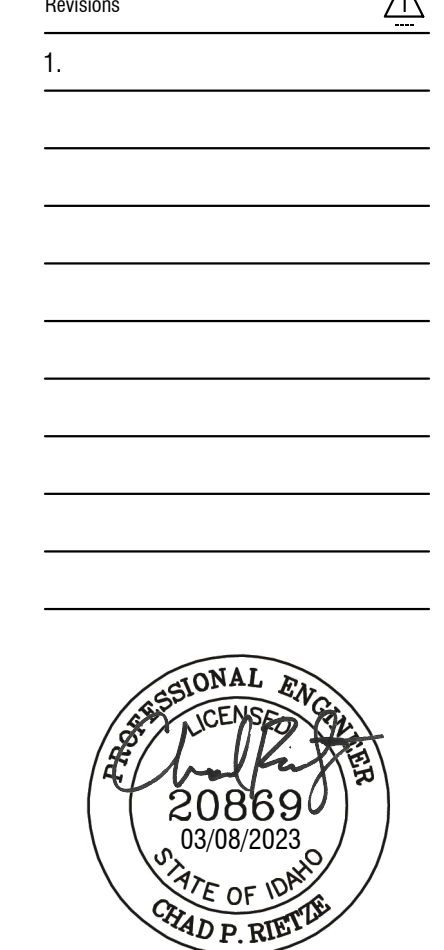

Project No.: 122129  
 Date of Issuance: 03.08.2023  
 Project Milestone: Construction Documents

Layout & Materials Plan

**C2.01**

**Site Materials & Layout Plan**  
 Horizontal Scale: 1" = 30'

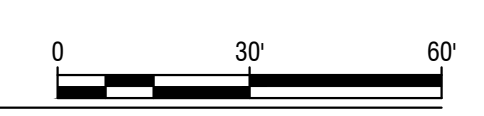

2023/03/08 10:52 AM C:\Users\p14444\OneDrive\Documents\2023\122129\122129\_C2.01\_Site Materials & Layout Plan.dwg  
 User: p14444  
 Plot Date: 03/08/2023 10:52 AM



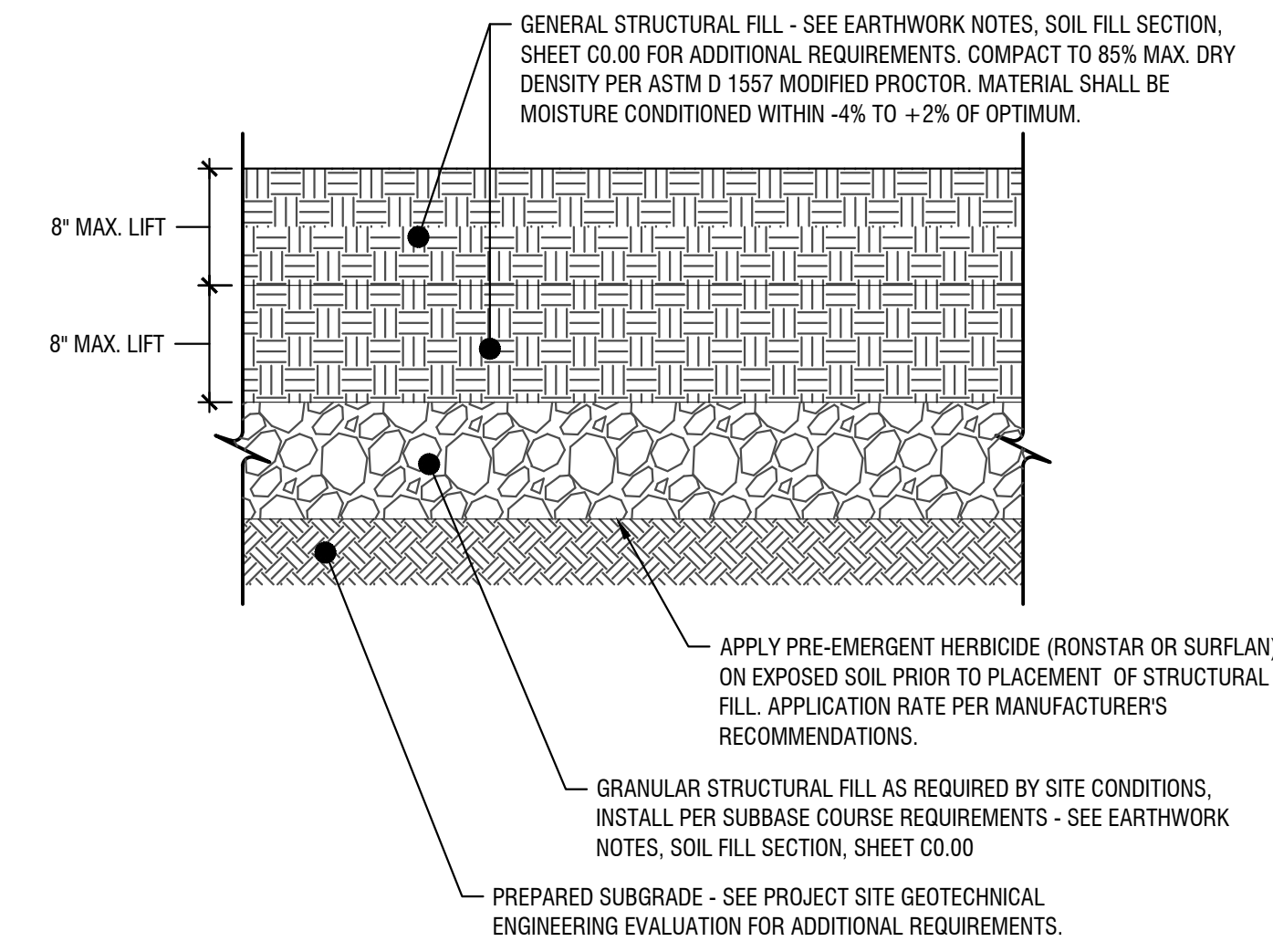

NOTE:  
1. PROJECT SITE GEOTECHNICAL ENGINEERING EVALUATION: (STRATA FILE NO. B016068A, DATED JULY 26, 2017).

**1 Flow Trail Pathway**  
Scale: NTS

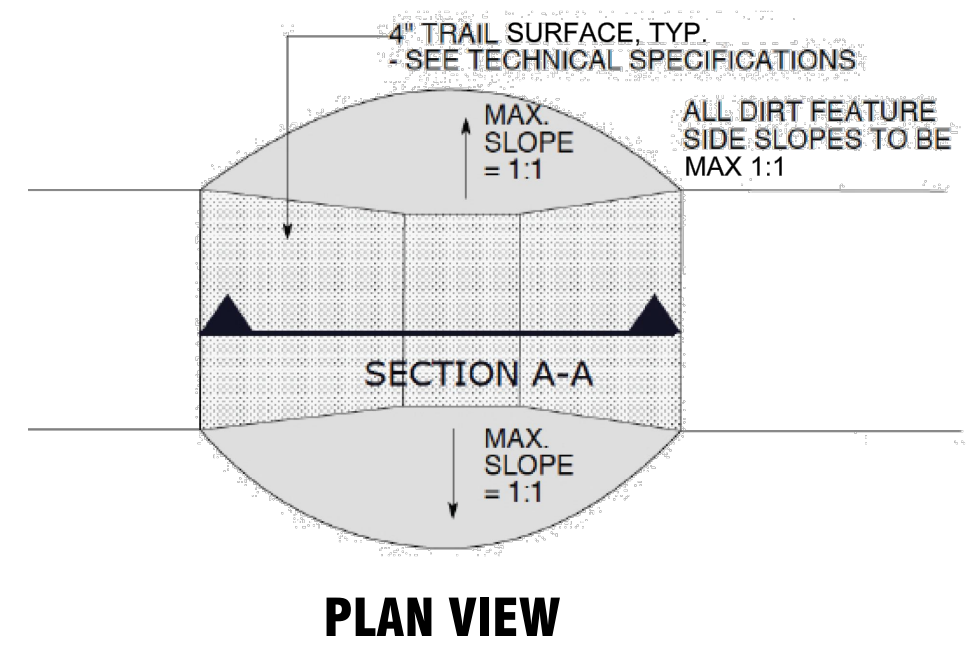

**2 Roller Detail**  
Scale: NTS

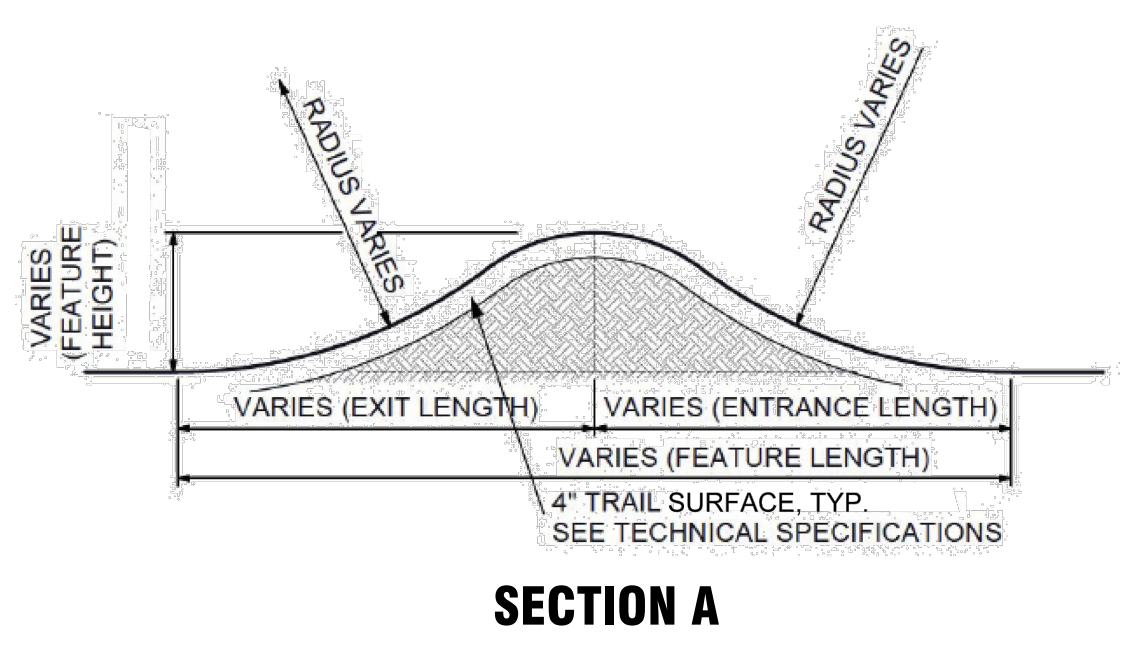

**3 Berm Detail**  
Scale: NTS

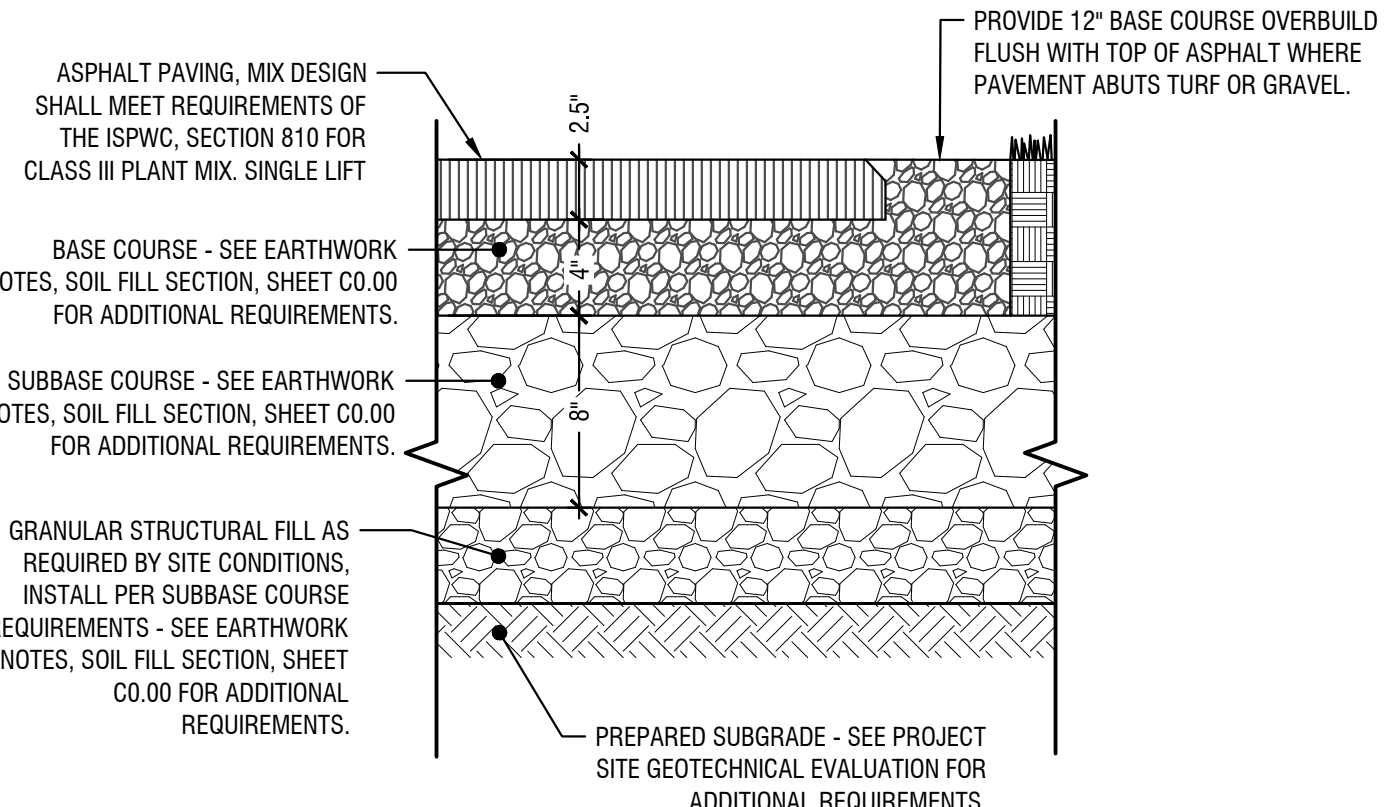
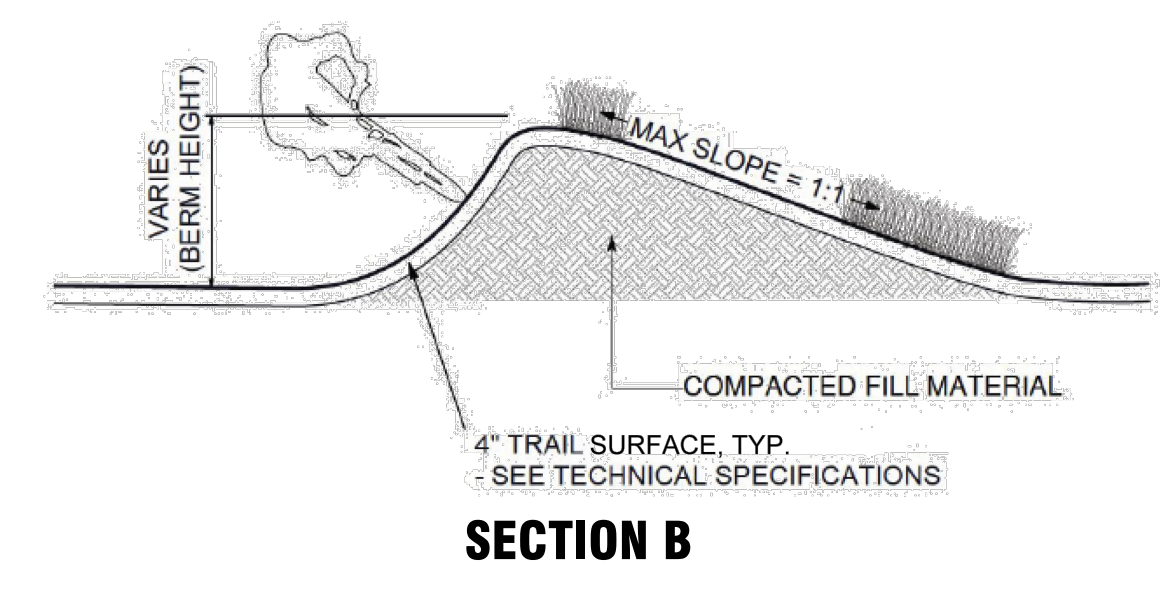
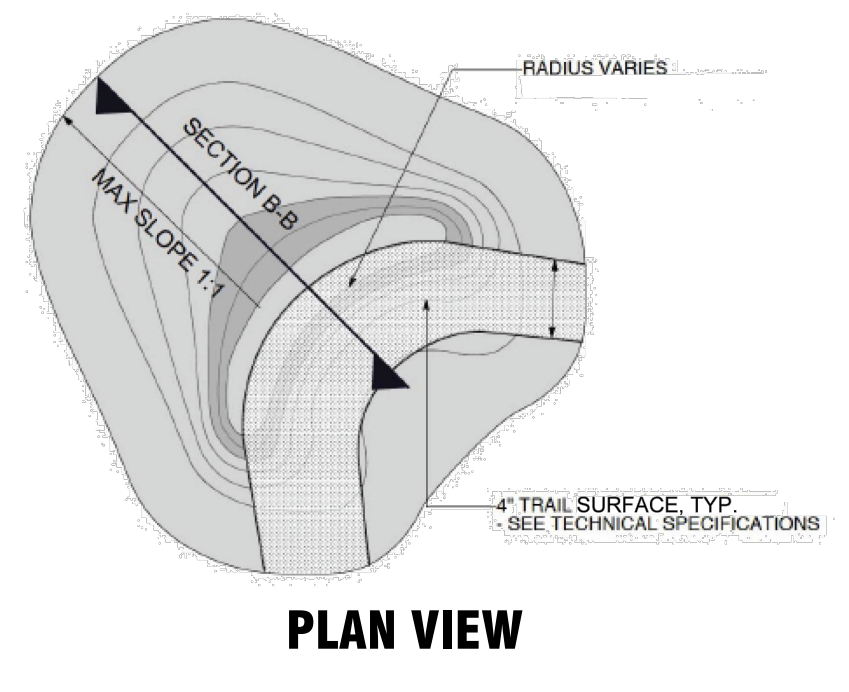

NOTES:  
1. NON-CONTAINED EDGES SHALL BE CLEAN AND STRAIGHT. HAND TAMP TO PROVIDE A 45° EDGE.  
2. ASPHALT PAVING SHALL BE COMPACTED TO 92% OF MAXIMUM DENSITY.  
3. PROJECT SITE GEOTECHNICAL EVALUATION: PREPARED BY STRATA, FILE NO. B016068A, DATED JULY 26, 2017

**4 Standard Duty Asphalt Pavement**  
Scale: 1-1/2" = 1'

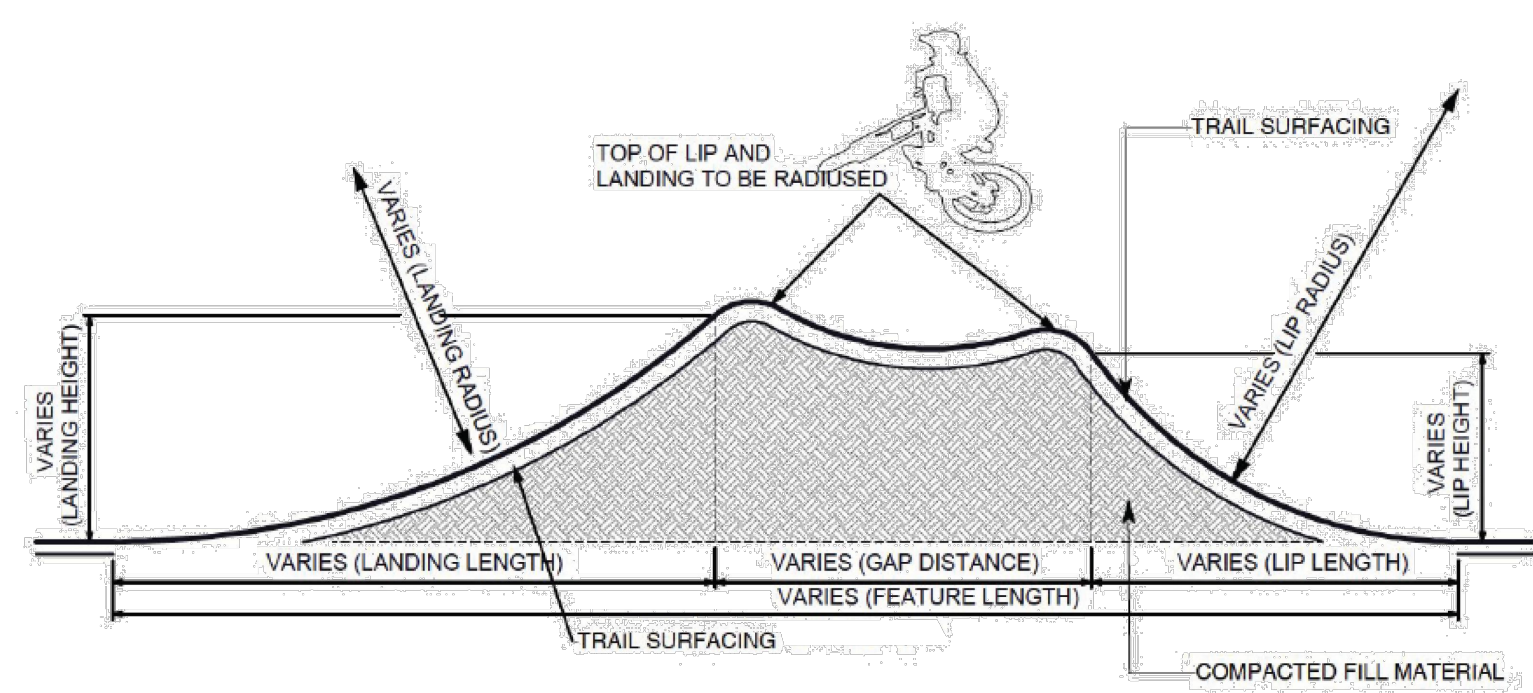

**5 Step Up Section**  
Scale: NTS

Revisions

1.	



Project No.: 122129  
Date of Issuance: 03.08.2023  
Project Milestone: Construction Documents

Site Details

**C2.50**



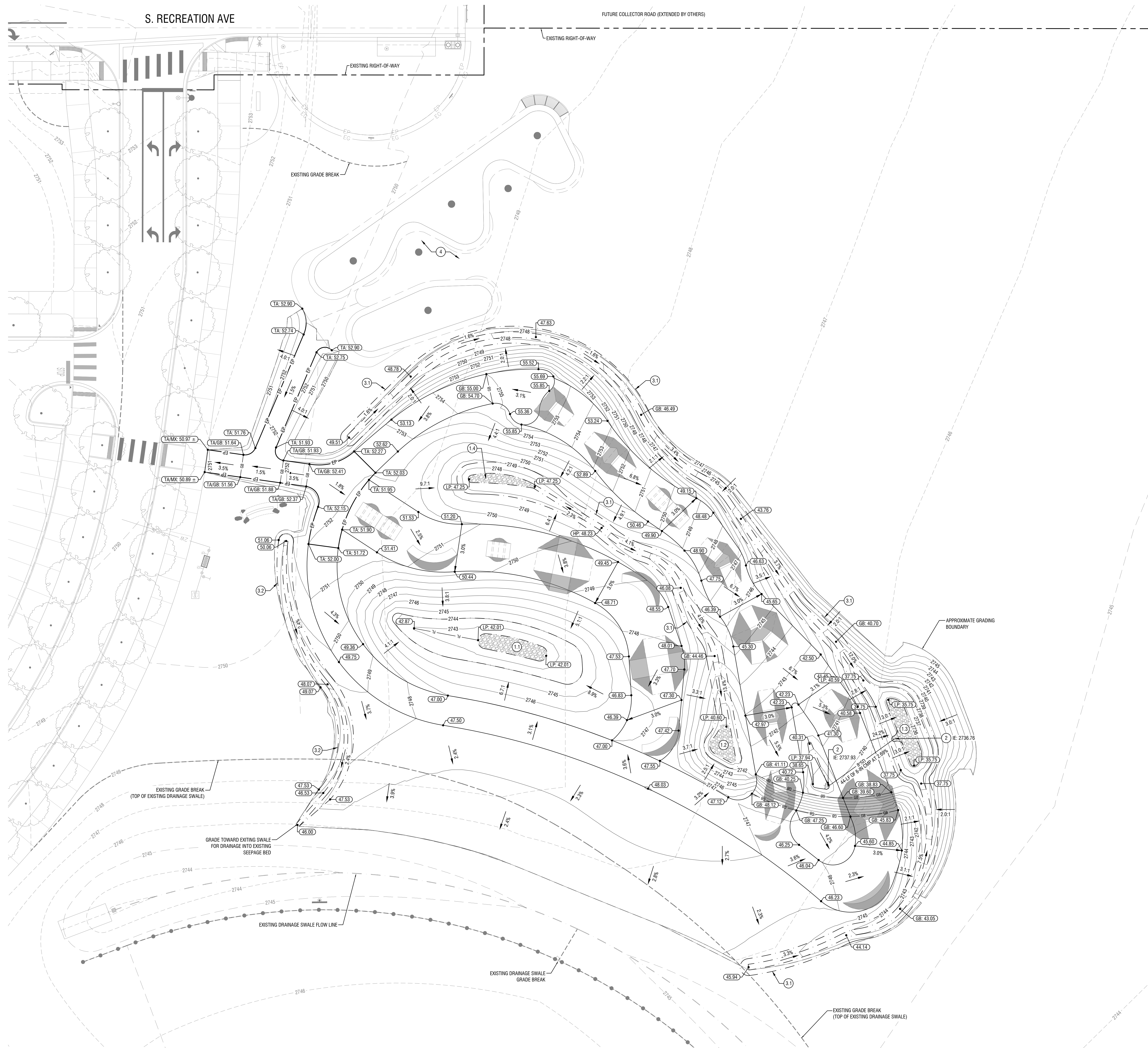

- Sheet Notes:**
- A. EXISTING AND PROPOSED CONTOURS ARE AT 1-FT INTERVALS.
  - B. ADD 2700' TO ALL SPOT ELEVATIONS FOR ACTUAL ELEVATION.
  - C. SPOT ELEVATIONS INDICATE TOP OF FINISH GRADE SURFACE UNLESS NOTED OTHERWISE AS FOLLOWS:  
 FL = FLOW LINE  
 GB = GRADE BREAK  
 HP = HIGH POINT  
 LP = LP OF GUTTER  
 LP = LOW POINT  
 MX = MATCH EXISTING  
 TA = TOP OF ASPHALT  
 TBC = TOP BACK OF CURB  
 TC = TOP OF CONCRETE
  - D. SIDEWALK HARDSCAPE SHALL NOT EXCEED 2.0% GROSS SLOPE OR HAVE GROSS SLOPE LESS THAN 1.0%. LONGITUDINAL SLOPES SHALL NOT EXCEED 5%. SLOPES WITHIN PEDESTRIAN RAMPS SHALL NOT EXCEED 1:2 (10%) NO TOLERANCES FOR SLOPES EXCEEDING MAXIMUMS WILL BE ALLOWED.
  - E. FINISH GRADE CONTOURS AND EARTHWORK VOLUMES DO NOT ACCOUNT FOR BIKE PARK FEATURES.
  - F. VOLUMES SHOWN IN EARTHWORK TABLE, THIS SHEET, ARE BASED ON DISCOVERY PARK: PHASE 2 DESIGN DRAWINGS. INFORMATION ON THIS SHEET DOES NOT ACCOUNT FOR ANY MATERIAL LEFT ON-SITE BY PHASE 2 CONTRACTOR.
  - G. PUMP TRACK GRADING AND DRAINAGE DESIGN SHALL BE COMPLETED BY OTHERS. THE LAND GROUP, INC. TAKES NO RESPONSIBILITY FOR WORK BY OTHERS.

- Keynotes:**
1. DRAINAGE WINDOW. SEE DETAIL 5/L1.50 AND LANDSCAPE PLAN FOR ADDITIONAL INFORMATION.
    - 1.1. INFILTRATION WINDOW AREA: 304-SF  
 DESIGN INFILTRATION RATE: 8 IN/HR  
 FREE DRAINING SOIL ANTICIPATED AT 1.75-FT BELOW FINISH GRADE
    - 1.2. INFILTRATION WINDOW AREA: 181-SF  
 DESIGN INFILTRATION RATE: 8 IN/HR  
 FREE DRAINING SOIL ANTICIPATED AT 1.25-FT BELOW FINISH GRADE
    - 1.3. INFILTRATION WINDOW AREA: 284-SF  
 DESIGN INFILTRATION RATE: 8 IN/HR  
 FREE DRAINING SOIL ANTICIPATED AT FINISH GRADE
    - 1.4. INFILTRATION WINDOW AREA: 158-SF  
 DESIGN INFILTRATION RATE: 8 IN/HR  
 FREE DRAINING SOIL ANTICIPATED AT 6.35-FT BELOW FINISH GRADE
  2. DRAINAGE CULVERT. INSTALL FLARED END SECTION ON BOTH SIDES OF CULVERT. PROVIDE D<sub>90</sub> = 0.50 RIP-RAP AT EACH END AND 1-FT ON EITHER SIDE OF PIPE. RIP-RAP SHALL BE SET FLUSH WITH PROPOSED FINISH GRADE AT INVERT.
    - 3.1. 3-FT FLAT BOTTOM.
    - 3.2. 2-FT FLAT BOTTOM.
  3. CONVEYANCE SWALE. GRADING PER PLAN.
    - 3.1. 3-FT FLAT BOTTOM.
    - 3.2. 2-FT FLAT BOTTOM.
  4. PUMP TRACK, GRADING AND DRAINAGE BY OTHERS.

**Line Legend:**

— GB — GRADE BREAK  
 — FL — FLOW LINE

**Bike Park:  
Estimated Earthwork Volumes**

TOTAL CUT (-)	4,085-CY
TOTAL FILL (+)	2,350-CY
NET	1,735-CY (CUT)



**DISCOVERY BIKE PARK**  
 City of Meridian Parks & Recreation  
 2121 E LAKE HAZEL RD  
 MERIDIAN, ID 83642

Revisions:

1.	

Project No.: 122129  
 Date of Issuance: 03.08.2023  
 Project Milestone: Construction Documents

**Site Grading & Drainage Plan**

**C4.00**

**Site Grading & Drainage Plan**  
 Horizontal Scale: 1" = 20'

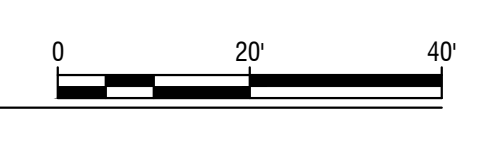

2023/03/08 10:52 AM C:\Projects\2023\03\08\20230308\Drawings\Site Grading & Drainage Plan.dwg  
 User: chad.kivner  
 Plot Date: 03/08/2023 10:52 AM





**Keynotes:**

1. LAWN AND HYDRO-SEED EDGE
2. DRAINAGE FACILITY/STRUCTURE. SEE GRADING AND DRAINAGE PLANS FOR MORE INFORMATION.

**Material Legend**

- TURF SOD: "EVER BLUE", 80% KENTUCKY BLUE AND 20% RYE OR APPROVED EQUAL. REFERENCE ALL SHEET NOTES ON L1.50.
- HYDRO-SEED STANDARD TURF MIX: 80% KENTUCKY BLUE AND 20% RYE. BLUE VARIETIES ARE EQUAL PARTS JACKPOT, EVERGLADE, NUBLUE, & BLUEYIP. PLUS. REFERENCE ALL SHEET NOTES ON L1.50.
- MEDIUM GRIND WOOD MULCH AT 3" DEPTH, LOCALLY SOURCED. REFERENCE ALL SHEET NOTES ON L1.50.
- BASALT BOULDERS, 3'-4" DIA. LOCALLY SOURCED, SEE DETAIL 2/L1.50.

**PLANT SCHEDULE**

TREES	CODE	BOTANICAL / COMMON NAME	SIZE	QTY
	LE	LIRIODENDRON TULIPIFERA 'EMERALD CITY' TM / EMERALD CITY TULIP TREE CLASS III: 55' H X 25' W	2" CAL.	7



NOTES:

- 1. THE STAKING OF TREES IS TO BE THE CONTRACTOR'S OPTION; HOWEVER, THE CONTRACTOR IS RESPONSIBLE TO INSURE THAT ALL TREES ARE PLANTED STRAIGHT AND THAT THEY REMAIN STRAIGHT FOR A MINIMUM OF 1 YEAR. ALL STAKING SHALL BE REMOVED AT THE END OF THE ONE YEAR WARRANTY PERIOD.
2. IN THE EVENT OF A QUESTION OR LACK OF CLARITY ON THE DRAWINGS, THE CONTRACTOR IS TO NOTIFY THE LANDSCAPE ARCHITECT BEFORE PROCEEDING.
3. LANDSCAPE CONTRACTOR IS TO NOTIFY THE LANDSCAPE ARCHITECT AND OWNER PRIOR TO INSTALLATION OF PLANT MATERIAL.
4. WRAP RUBBER CINCH TIES AROUND THE TREE TRUNKS AND STAKES USING EITHER THE STANDARD OR FIGURE EIGHT TYING METHOD. SECURE THE TIES TO THE STAKES WITH GALVANIZED NAILS TO PREVENT SLIPPAGE.
5. WATER TREE TWICE WITHIN THE FIRST 24 HOURS.
6. IN THE EVENT HARDPAN SOILS PREVENT TREE PLANTING AS DETAILED, NOTIFY THE LANDSCAPE ARCHITECT IMMEDIATELY.

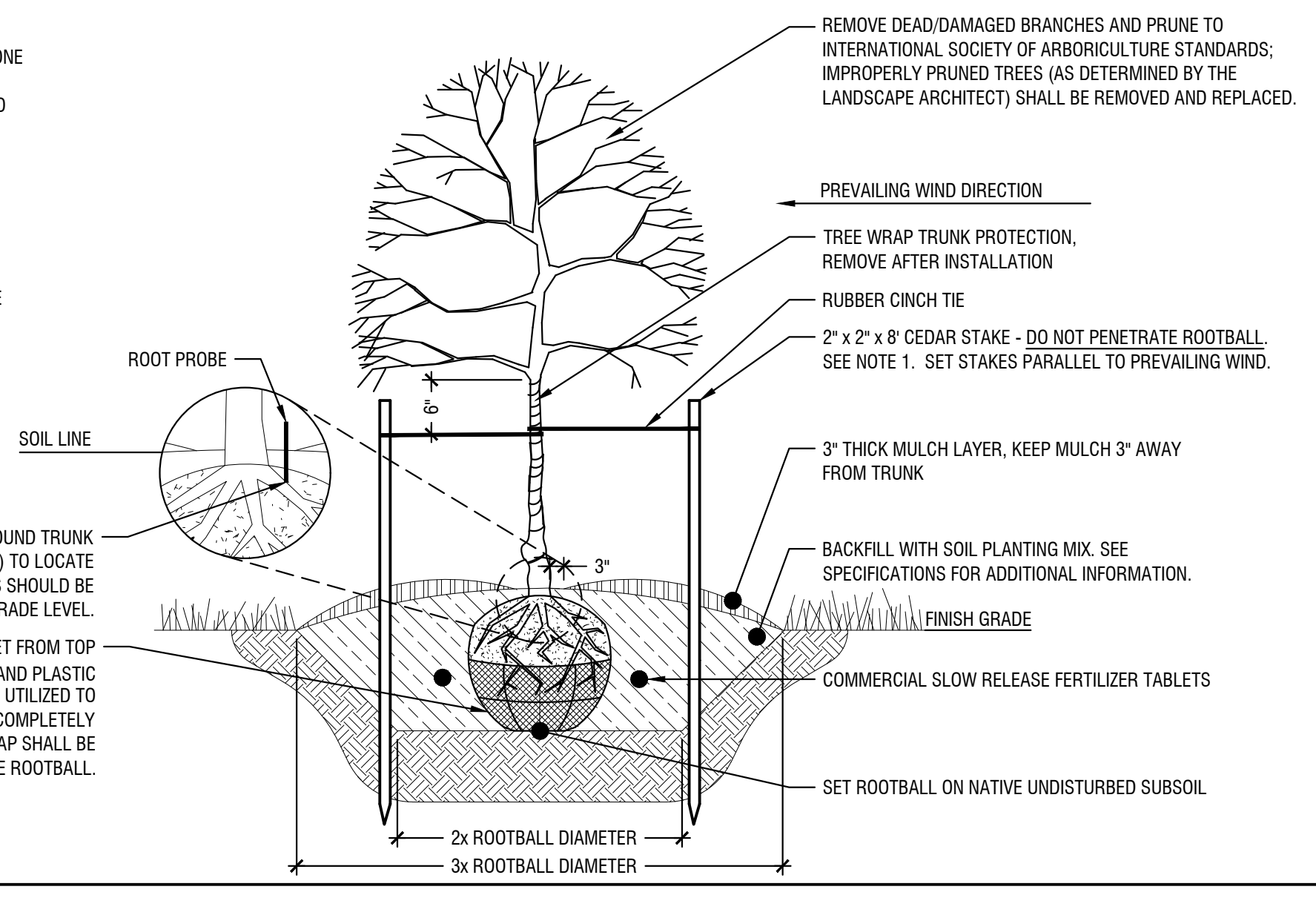

1 Deciduous Tree Planting

Scale: NTS

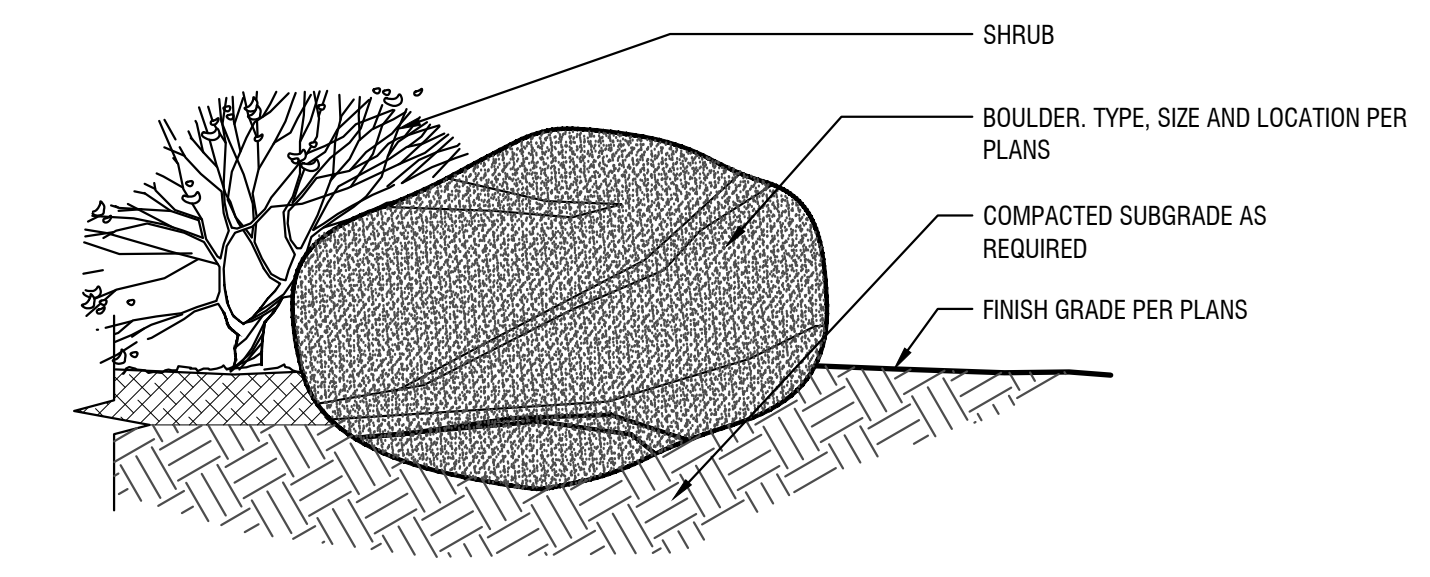

NOTES:

- 1. NOTIFY LANDSCAPE ARCHITECT WHEN PLACING BOULDERS FOR APPROVAL.
2. PLACE BOULDERS PRIOR TO INSTALLATION OF IRRIGATION SYSTEM.
3. CLEAN ALL BOULDERS OF DIRT AND LOOSE DEBRIS.
4. WHEN PLACING BOULDERS, BURY 1 TO 1 1/2 OF BOULDER BELOW FINISH GRADE.
5. DO NOT SCAR OR DAMAGE BOULDERS.

2 Boulder Installation

Scale: NTS

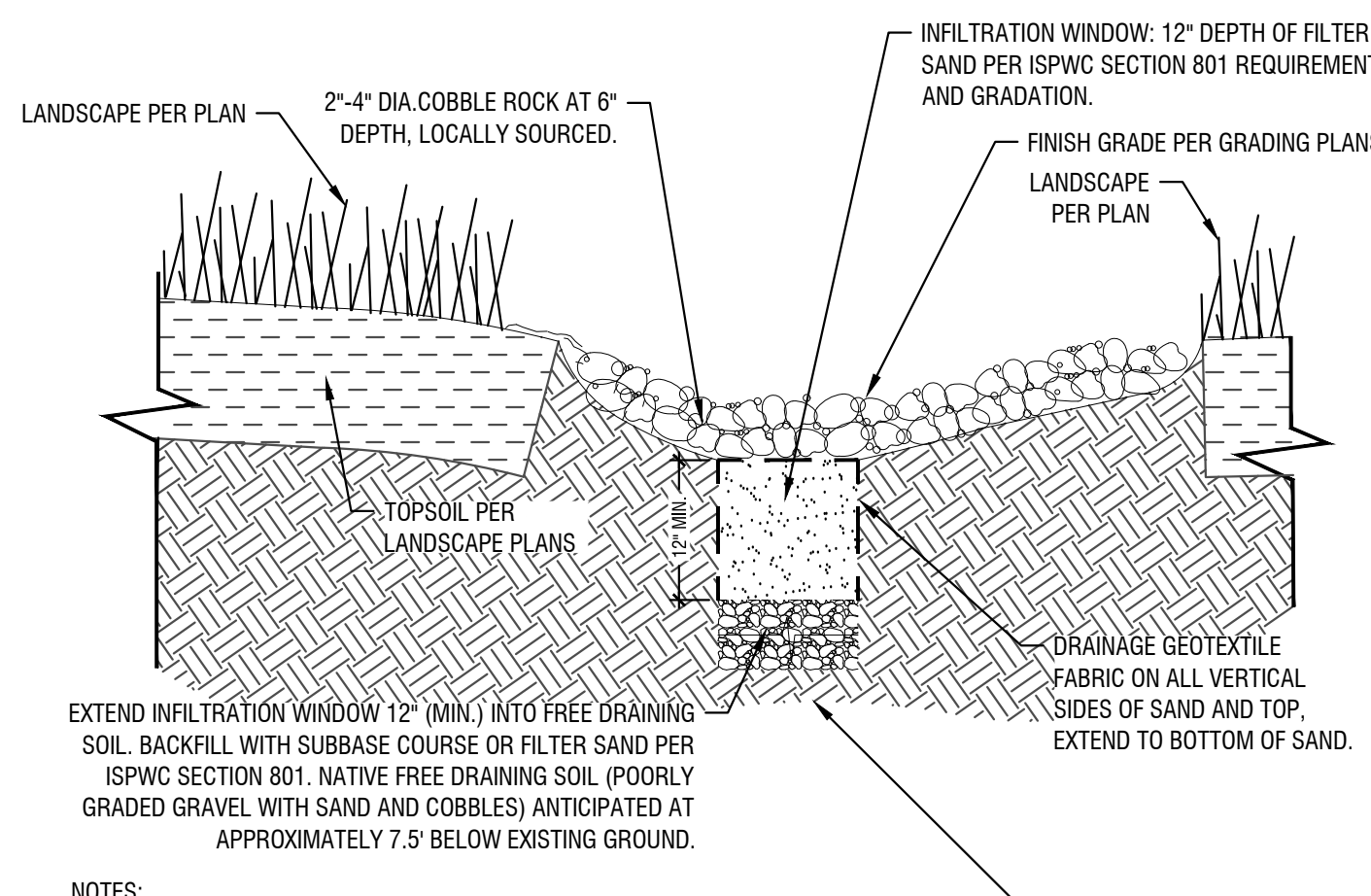

NOTES:

- 1. COMPACTION OF THE INFILTRATION WINDOW SHALL BE AVOIDED.
2. SLOPE SWALE TO INFILTRATION WINDOW, SEE GRADING PLANS FOR MORE INFORMATION.
3. CONTRACTOR SHALL CONTACT DESIGN ENGINEER FOR INSPECTION AND VERIFICATION OF EXCAVATION TO FREE DRAINING SOILS PRIOR TO IMPORT BACKFILL. PROVIDE 24-HR NOTICE OF INSPECTION.
4. BOTTOM OF SWALE SHALL BE 3-FT MINIMUM FROM SEASONAL HIGH GROUND/WATER (SHGW).
5. SHGW IS ANTICIPATED TO BE GREATER THAN 20-FT BENEATH EXISTING GROUND SURFACE PER GEOTECHNICAL EVALUATION PREPARED BY STRATA (FILE NO. 8016088A, DATED JULY 26, 2017).

3 Drainage Swale and Adjacent Landscapes

Scale: NTS

Landscape Notes:

- A. CONTRACTOR SHALL REPORT TO LANDSCAPE ARCHITECT ALL CONDITIONS WHICH IMPAIR AND/OR PREVENT THE PROPER EXECUTION OF THIS WORK, PRIOR TO BEGINNING WORK.
B. IN THE EVENT OF A DISCREPANCY, NOTIFY THE LANDSCAPE ARCHITECT IMMEDIATELY.
C. CONTRACTOR TO VERIFY LOCATION OF ALL UTILITIES PRIOR TO INITIATION OF ANY DEMOLITION OR CONSTRUCTION OPERATIONS. ANY DAMAGE TO EXISTING UTILITIES SHALL BE CONTRACTOR'S RESPONSIBILITY.
D. NO SUBSTITUTIONS FOR ANY OF THE SPECIFIED PRODUCTS WILL BE ALLOWED WITHOUT THE WRITTEN CONSENT OF THE LANDSCAPE ARCHITECT.
E. CONTRACTOR SHALL REFERENCE CIVIL DRAWINGS TO CONFORM LANDSCAPE GRADING. ALL EXISTING OR NEW LANDSCAPE AREAS ABUTTING NEW FLATWORK OR DIRT BIKE PATH SHALL BE GRADED TO PROVIDE A UNIFORM SLOPE AWAY FROM FLATWORK/DIRT BIKE PATH, WHETHER OR NOT LANDSCAPE GRADING IS DESCRIBED ON PLANS. PROVIDE A SMOOTH TRANSITION FROM FLATWORK/DIRT BIKE PATH TO ABUTTING LANDSCAPE.
F. ANY EXISTING LANDSCAPE AREAS REQUIRING A GRADE ADJUSTMENT SHALL BE REPAIRED TO A HEALTHY CONDITION.
G. CONTRACTOR SHALL PROVIDE A SMOOTH TRANSITION FROM EXISTING TURF AREAS TO NEW SEED/SOD AREAS.
H. ALL PLANT MATERIAL SHALL CONFORM TO THE CURRENT AMERICAN ASSOCIATION OF NURSERYMAN'S NATIONAL STANDARD SPECIFICATIONS.
I. ALL PLANT MATERIAL SHALL BE INSTALLED AS PER DETAILS AND DRAWING NOTES. CONTRACTOR SHALL COORDINATE PLANTING WITH IRRIGATION CONTRACTOR.
J. FINISH GRADES TO BE SMOOTH AND EVEN GRADIENTS WITH POSITIVE DRAINAGE IN ACCORDANCE WITH SITE GRADING PLAN, REMOVE RIDGES AND FILL DEPRESSIONS, AS REQUIRED TO MEET FINISH GRADES. PLACE MULCH (TYPE PER PLANS) OVER SUBGRADE SOIL TO ACHIEVE FINISH GRADE. FINISH GRADE RELATED TO ADJACENT SITE ELEMENTS SHALL BE:
K.1. 1-INCH BELOW TOP OF ADJACENT PAVEMENT, VALVE BOX, VAULT, ETC.
K.2. 3-INCHES BELOW TOP OF CURB UNLESS NOTED OTHERWISE.
L. ALL PLANTING SEEDS SHALL HAVE A MINIMUM OF 18% TOPSOIL. SOD AREAS A MINIMUM OF 12" OF TOPSOIL. SPREAD, COMPACT AND FINE GRADE TOPSOIL TO A SMOOTH AND UNIFORM GRADE.
M. RE-USE EXISTING SURFACE TOPSOIL, WHERE POSSIBLE. VERIFY SUITABILITY OF SURFACE SOIL TO PRODUCE TOPSOIL MEETING REQUIREMENTS AND AMEND WHEN NECESSARY. TOPSOIL SHALL BE A LOOSE, FRABLE, SANDY LOAM, CLEAN AND FREE OF TOXIC MATERIALS, NOXIOUS WEEDS, WEED SEEDS, ROCKS, GRASS OR OTHER FOREIGN MATERIAL AND A PH OF 6.5 TO 7.5. IF ON-SITE TOPSOIL DOES NOT MEET THESE MINIMUM STANDARDS, CONTRACTORS ARE RESPONSIBLE TO EITHER: A) PROVIDE APPROVED IMPORTED TOPSOIL, OR B) IMPROVE ON-SITE TOPSOIL WITH METHODS APPROVED BY LANDSCAPE ARCHITECT. SUPPLEMENT WITH IMPORTED TOPSOIL WHEN QUANTITIES ARE INSUFFICIENT. CLEAN TOPSOIL OF ROOTS, PLANTS, SODS, STONES, CLAY LUMPS AND OTHER EXTRANEIOUS MATERIALS HARMFUL TO PLANT GROWTH.
N. IF IMPORTED TOPSOIL FROM OFF-SITE SOURCES IS REQUIRED, PROVIDE NEW TOPSOIL THAT IS FERTILE, FRABLE, NATURAL LOAM, SODS, STONES, CLAY LUMPS AND OTHER EXTRANEIOUS MATERIALS HARMFUL TO PLANT GROWTH.
O. OBTAIN TOPSOIL FROM LOCAL SOURCES OR FROM AREAS HAVING SIMILAR SOIL CHARACTERISTICS TO THAT FOUND AT PROJECT SITE. OBTAIN TOPSOIL ONLY FROM NATURALLY, WELL-DRAINED SITES WHERE TOPSOIL OCCURS IN A DEPTH OF NOT LESS THAN 4 INCHES.
P. ALL LANDSCAPE AREAS SHALL BE WEED FREE AT THE TIME OF LANDSCAPE INSTALLATION. REMOVE ALL ROOTS, WEEDS, ROCKS AND FOREIGN MATERIAL ON THE SURFACE.
Q. NEW TREE PLANTING: SEE DETAIL 1.01.50. CONTRACTOR SHALL STAKE ALL TREES DEEMED NECESSARY, I.E. FROM BEING BLOWN OVER, PLANTED WITH LOOSE ROOT BALL, ETC. CONTRACTOR'S OPTION.
R. ALL PLANT MATERIAL SHALL CONFORM TO THE AMERICAN NURSERYMAN STANDARDS FOR TYPE AND SIZE SHOWN. PLANTS WILL BE REJECTED IF NOT IN A SOUND AND HEALTHY CONDITION.
S. ALL PLANT MATERIAL SHALL BE GUARANTEED FOR A PERIOD OF ONE YEAR BEGINNING AT THE DATE OF SUBSTANTIAL COMPLETION, REPLACE ALL PLANT MATERIAL FOUND DEAD OR NOT IN A HEALTHY CONDITION IMMEDIATELY WITH THE SAME SIZE AND SPECIES AT NO COST TO THE OWNER.
T. TREE PIT BACKFILL: PLANTING MIX: BLEND TOPSOIL AND SOIL AMENDMENTS AND FERTILIZER FOR TREE PIT BACKFILL AT THE FOLLOWING RATES: BLEND AMENDMENTS THOROUGHLY WITH SOIL BACKFILL. TREE PITS SHALL BE 3x3x1.5 (37.5 CF, 1.5 CY).
T.1. APPLICATION RATES:
-HUMIC ACID: 25 LBS PER TREE PIT
-COMMERCIAL GRADE COMPOST: 10 CUBIC FEET PER TREE PIT
-PLANTING TABLET FERTILIZER: 4 TABLETS PER TREE PIT (AGRIFORM 20-10-5)
-CALCIED DIATOMACEOUS EARTH: 75 LBS PER TREE PIT
U. IMMEDIATELY CLEAN UP ANY TOPSOIL OR OTHER DEBRIS ON THE SITE CREATED FROM LANDSCAPE OPERATIONS AND DISPOSE OF PROPERLY OFF SITE.
V. CONTRACTOR SHALL SUBMIT MATERIAL SAMPLES FOR LANDSCAPE MULCH TO LANDSCAPE ARCHITECT FOR APPROVAL PRIOR TO PROCUREMENT. LANDSCAPE BOULDERS, PHOTO SUBMITTAL IS ADEQUATE FOR BARK MULCH, SUBMIT 1 GALLON BAG SAMPLE TO OWNER.

Landscape & Irrigation Preservation Notes:

- 1. CONTRACTOR SHALL ENSURE 100% FUNCTIONALITY OF EXISTING IRRIGATION SYSTEM DURING AND AFTER CONSTRUCTION.
2. CONTRACTOR SHALL REPLACE/REPAIR ANY DAMAGED LANDSCAPE, LAWN, EXISTING PIPING AND/OR COMPONENTS AT NO COST TO OWNER.

Hydro-Seeding Notes

- A. MATERIALS
A.1. HYDRO-MULCH MATERIAL:
A.1.a. CELLULOSE WOOD FIBER WITH NO GROWTH OR GERMINATION INHIBITING FACTORS. DYED GREEN. MATERIAL SHALL HAVE EQUILIBRIUM AIR-DRY MOISTURE CONTENT OF TWELVE (12) PERCENT, PLUS OR MINUS TWO (2) PERCENT, AT TIME OF MANUFACTURE.
A.1.b. FIBER SHALL DISPERSE RAPIDLY IN WATER FORMING HOMOGENEOUS SLURRY AND REMAINING IN SUCH STATE WHEN AGITATED IN HYDRO-MULCHING EQUIPMENT. QUALITY STANDARD: SOLIGUARD BY MAT INC, FLOODWOOD, MN WWW.MATINC.BIZ
A.2. BINDERS:
A.2.a. TACKIFIER TO BIND SOIL AND MULCH TOGETHER TO PREVENT EROSION.
A.2.b. AM-TAC BY AZ-TAC PRODUCTS INC, OR APPROVED EQUAL.
A.3. FUNGICIDE:
A.3.a. APPROVE THROUGH SUBMITTALS.
A.3.a.1. SEED SHALL BE PROVIDED FROM AND MIXED BY A CERTIFIED DEALER. SEED MIXTURE SHALL BE LABELED WITH MANUFACTURERS GUARANTEED ANALYSIS, GERMINATION RATE AND PURITY RATIO.
A.3.a.2. SEED TREATMENT: ONSET SEED NECTAR. MANUFACTURED BY NECTERANAL, IDAHO FALLS, ID, CONTACT DAVE (208)680-0578, TOLL FREE (866)767-7996 OR WWW.NECTERANAL.COM. WATER: CLEAN, FRESH AND FREE OF SUBSTANCES OR MATTER WHICH COULD INHIBIT VIGOROUS GROWTH OF GRASS.
B. MIXES:
B.1. AMOUNT OF HYDRO-MULCH SHALL BE APPROX. 1800 LBS PER ACRE.
B.2. ADD WATER AS NECESSARY TO PROVIDE SUITABLE SLURRY MIXTURE.
B.3. ADD FUNGICIDE AT RATES RECOMMENDED BY MANUFACTURER ON INSTALLATIONS MADE BETWEEN 1ST OF APRIL AND 30 SEPTEMBER.
B.4. SPECIALTY SEEDED AREAS: ADD BINDER AT RATES RECOMMENDED BY MANUFACTURER ALWAYS WHERE SLOPES ARE 5:1 OR OVER, AND ALL OTHER AREAS BETWEEN 1ST OF OCTOBER AND 31 MARCH.
C. APPLICATION:
C.1. TOLERANCES:
C.1.a. FINAL GRADE OF SOIL AFTER SEEDING OF LAWN AREAS IS COMPLETE SHALL BE ONE INCH BELOW TOP OF ADJACENT PAVEMENT OF ANY KIND.
C.1.b. ALL PLANTING AREAS SHALL BE WEED FREE AT THE TIME OF SEED INSTALLATION.
C.2. AFTER SEED AREAS ARE GRADED, APPLY SPECIFIED SLURRY MIX WITH MACHINE CAPABLE OF CONTINUOUSLY MIXING SLURRY AND PROVIDING AN APPLICATION MEETING CONTRACT DOCUMENT REQUIREMENTS. HYDRO-MULCH SHALL FORM AN ABSORPTIVE MAT, BUT NOT A PLANT INHIBITING MEMBRANE, WHICH WILL ALLOW WATER TO PERCOLATE INTO UNDERLYING SOIL.
C.3. POST APPLICATION WATERING:
C.3.a. ALLOW SLURRY MIXTURE TO 'SET'.
C.3.b. WATER HYDRO-SEEDED AREAS SUFFICIENTLY TO INSURE PROPER SEED GERMINATION, BUT NOT CAUSE EROSION OR SLOPE FAILURE. REPEAT WATERING AT REGULAR INTERVALS TO KEEP SEED GERMINATING AND GROWING UNTIL PLANTINGS ARE ESTABLISHED.
C.3.c. AFTER PLANTINGS ARE ESTABLISHED, DECREASE FREQUENCY AND INCREASE AMOUNT OF WATER PER APPLICATION AS NECESSARY TO MEET PLANT WATER REQUIREMENTS.
C.4. IF FUNGICIDE HAS BEEN APPLIED WITH SLURRY MIX, MAKE A SECOND APPLICATION OF FUNGICIDE FOURTEEN (14) DAYS AFTER INITIAL APPLICATION.
D. WEED ABATEMENT:
D.1. ALL AREAS TO BE SEEDDED SHALL HAVE WEED ABATEMENT OPERATIONS PERFORMED AFTER PLACEMENT OF SOIL AMENDMENTS AND FINISH GRADING AND PRIOR TO SEEDING OPERATIONS.
D.2. UPON COMPLETION OF FINISH GRADING, THE CONTRACTOR SHALL CONFIRM ALL AREAS ARE VISIBLY WEED FREE. CONTRACTOR SHALL SPRAY ALL EXPOSED WEEDS WITH COMBINATION OF 2-4-D AND ROUNDUP. COMPLY WITH MIXING/APPLICATION INSTRUCTIONS ON PRODUCT LABEL. DO NOT WATER FOR AT LEAST THREE (3) DAYS FOLLOWING APPLICATION.
D.3. IRRIGATE ALL LANDSCAPE AREAS TO APPLY 1-INCH OF PRECIPITATION OVER A 2 DAY PERIOD, AT CONCLUSION OF THIS WATERING PERIOD, DISCONTINUE WATERING FOR SEVEN (7) DAYS.
D.4. AFTER SEVEN DAY PERIOD INSPECT THE SITE. APPLY APPLICATION OF COMBINATION 2-4-D AND ROUNDUP TO ALL VISIBLE WEEDS. APPLY IN STRICT CONFORMANCE WITH MANUFACTURERS PRODUCT LABEL. DO NOT WATER FOR AT LEAST THREE (3) DAYS. REMOVE ALL EXPOSED WEEDS FROM THE SITE.
D.5. WEED ABATEMENT OPERATIONS SHALL BE DISCONTINUED TO BE COMPLETE NO MORE THAN 7 DAYS PRIOR TO SEEDING OPERATIONS. IT IS ACCEPTABLE TO PHASE WEED ABATEMENT AREAS TO MATCH PHASED INSTALLATION OF SEED AREAS.

Soil Amendment Notes:

- A. PRODUCTS
A.1. SOIL AMENDMENT: COMPOST
A.1.a. COMPOST SHALL BE MEASURED BY THE CUBIC YARD AT THE POINT OF LOADING.
A.1.b. COMPOST SHALL BE A WELL DECOMPOSED, STABLE, WEEDFREE ORGANIC MATTER SOURCE. IT SHALL BE DERIVED FROM AGRICULTURAL, FOOD, OR INDUSTRIAL RESIDUALS, BIOSOLIDS (TREATED SEWAGE SLUDGE), YARD TRIMMINGS OR SOURCE-SEPARATED OR MIXED SOLID WASTE. THE PRODUCT SHALL CONTAIN NO SUBSTANCES TOXIC TO PLANTS, WILL POSSESS NO OBJECTIONABLE ODOORS AND SHALL NOT RESEMBLE THE RAW MATERIAL FROM WHICH IT WAS DERIVED.
A.1.c. COMPOST SHALL MEET THE FOLLOWING PARAMETERS:
1) PH - ACCEPTABLE RANGE: 6.0 - 8.4 (15 BY WEIGHT)
2) SOLUBLE SALTS - ACCEPTABLE RANGE: 0-7 MMHOS/CM (1.5 BY WEIGHT)
3) MATURITY INDICATORS:
a. AMMONIA N / NITRATE N RATIO - < 4
b. CARBON TO NITROGEN RATIO - < 12
4) PARTICLE SIZE: 98% PASS THROUGH 1/2-INCH SCREEN
5) PHYSICAL CONTAMINANTS (INERT MATTER): LESS THAN 1%
6) SUBMIT LAB TESTING INDICATING COMPLIANCE WITH THE PARAMETERS ABOVE. LAB TESTING SHALL ALSO PROVIDE THE FOLLOWING INFORMATION: BULK DENSITY, % INORGANICS, % MOISTURE, PARTICLE SIZE DISTRIBUTION, PRIMARY & SECONDARY NUTRIENTS, TRACE ELEMENTS, ORGANIC MATTER EXPRESSED IN PERCENTAGE AND POUNDS PER CY.
A.2. SOIL AMENDMENT: PRE PLANT FERTILIZER.
A.2.a. PLANT/TREE NPK PRE-PLANT; APEX 14-14-14 WITH GAL-XE-ONE.
A.2.b. HUMIC ACID: LIVE EARTH HUMATE SOIL CONDITIONER.
A.2.c. OR APPROVED EQUAL.
A.3. SOIL AMENDMENT: TURF STARTER FERTILIZER.
A.3.a. SIMPLOT BEST TRIPLE PRO 15-15-15.
A.3.b. OR APPROVED EQUAL.
B. EXECUTION
B.1. SOIL AMENDMENTS: AFTER APPROXIMATE FINISHED GRADES HAVE BEEN ESTABLISHED SOIL SHALL BE CONDITIONED AND FERTILIZED IN THE FOLLOWING MANNER. SOIL AMENDMENTS SHALL, AT THE FOLLOWING RATE, BE UNIFORMLY SPREAD AND CULTIVATED THOROUGHLY BY MEANS OF MECHANICAL TILLER INTO THE TOP SOIL LAYER, MINIMUM 4 INCH DEPTH AND MAXIMUM 6 INCH DEPTH. APPLICATION RATES: PER MANUFACTURER'S STANDARDS.
B.1.a. APPLICATION RATES: PER MANUFACTURER'S STANDARDS.
B.2. PLACEMENT AND TILLING OF SOIL AMENDMENTS LISTED IN THIS SECTION MUST BE COMPLETED PRIOR TO SOD PLACEMENT. CONTRACTOR SHALL PHOTO DOCUMENT INSTALLATION OF ALL SOIL AMENDMENTS AND MECHANICAL TILLING AND PROVIDE TO THE ARCHITECT FOR REVIEW AND APPROVAL.

Establishment & Maintenance Notes:

- SOD ESTABLISHMENT
A. GENERAL: STARTING IMMEDIATELY AFTER SOD PLACEMENT, SOD ESTABLISHMENT WILL BEGIN. IRRIGATION, MOWING, WEED CONTROL AND FERTILIZATION SHALL BE THE RESPONSIBILITY OF THE CONTRACTOR AS DEFINED HEREIN. PROTECT SODDED AREA WITH SIGNS TO PREVENT TRAFFIC THROUGHOUT THE ESTABLISHMENT PERIOD.
B. THE ESTABLISHMENT PERIOD SHALL HAVE A DURATION OF THIRTY (30) DAYS.
C. IRRIGATION:
1. CONTRACTOR SHALL SUBMIT FOR APPROVAL A PROPOSED 'SOD ESTABLISHMENT IRRIGATION SCHEDULE' TO THE OWNER'S REPRESENTATIVE. THIS SCHEDULE SHALL INCLUDE ZONE DESIGNATION, DAYS PER WEEK, CYCLES PER DAY AND CYCLE RUN TIME. INCLUDE TARGETED DAILY AND WEEKLY PRECIPITATION RATES FOR EACH ZONE BASED ON CURRENT CLIMATIC CONDITIONS.
2. WATER SHALL BE APPLIED TO MOISTEN THE SOIL TO APPROXIMATELY 2-INCH DEPTH BUT AVOID OVER-WATERING AND CREATING AREAS OF STANDING WATER OR UNDER WATERING AND CREATING AREAS OF DRY SOIL.
3. CONTRACTOR SHALL MONITOR IRRIGATION DAILY TO IDENTIFY AREAS RECEIVING TOO MUCH OR TOO LITTLE PRECIPITATION.
4. SLOPES SHALL BE MONITORED FOR EROSION AND CORRECTIVE ACTION TAKEN IMMEDIATELY.
5. ONCE THE SOD HAS BEEN MOWN THREE TIMES, APPROXIMATELY 4 WEEKS, THE FREQUENCY OF IRRIGATION SHALL BE REDUCED AND RUN TIMES INCREASED TO PROVIDE WATER DEEPER INTO THE SOIL.
D. MOWING:
1. MOWING SHALL BEGIN WHEN THE GRASS BLADES REACH A HEIGHT OF APPROXIMATELY 2.5-INCHES.
2. ALL CUTTING EQUIPMENT SHALL BE SHARP AND MOWERS SHALL BE ADJUSTED PRECISELY TO THE PROPER MOWING HEIGHT.
3. MOWING HEIGHTS DURING THE ESTABLISHMENT PERIOD SHALL BE 2.5-INCH TO 3-INCH.
4. MOWING SHALL OCCUR EVERY 7 DAYS OR MORE OFTEN IF GROWTH DICTATES. AT NO POINT SHALL THE HEIGHT OF THE TURF GRASS BE MORE THAN 3.5-INCHES.
5. GRASS CLIPPINGS SHALL BE COLLECTED AND REMOVED FROM THE SITE.
6. COORDINATE IRRIGATION SCHEDULE WITH MOWING SCHEDULE. AT NO TIME SHALL MOWING OCCUR IF SOIL IS WET AND RUTTING MAY OCCUR.
E. WEED CONTROL: CONTROL GROWTH OF WEEDS THROUGHOUT ESTABLISHMENT PERIOD.
F. UPON COMPLETION OF THE ESTABLISHMENT PERIOD THE TURF MAINTENANCE PERIOD SHALL BEGIN.
TURF MAINTENANCE
A. MAINTENANCE SHALL BE ACCORDING TO THE FOLLOWING STANDARDS. ALL AREAS SHALL BE MOWN, WEEDED AND CULTIVATED AT INTERVALS OF NOT MORE THAN SEVEN (7) DAYS. WATERING, TRASH AND DEBRIS REMOVAL, MOWING, ROLLING, EDGING, TRIMMING, FERTILIZATION, SPRAYING AND PEST CONTROL, AS REQUIRED, SHALL BE INCLUDED IN THE MAINTENANCE PERIOD. CLEANING OF STREET GUTTERS AND SIDEWALKS SHALL BE INCLUDED. THE CONTRACTOR SHALL BE RESPONSIBLE FOR MAINTAINING ADEQUATE PROTECTION OF THE AREA. DAMAGED AREAS SHALL BE REPAIRED AT THE CONTRACTORS EXPENSE. THE CONTRACTOR SHALL RESEED ALL SPOTS OR AREAS WITHIN THE LAWN WHERE NORMAL TURF GROWTH IS NOT EVIDENT.
B. THE TURF MAINTENANCE PERIOD SHALL HAVE A MINIMUM DURATION OF SIXTY (60) DAYS AND CONTINUE UNTIL THE DATE OF SUBSTANTIAL COMPLETION.
C. IRRIGATION:
1. CONTRACTOR SHALL SUBMIT FOR APPROVAL A PROPOSED 'TURF MAINTENANCE IRRIGATION SCHEDULE'. THIS SCHEDULE SHALL INCLUDE ZONE DESIGNATION, DAYS PER WEEK, CYCLES PER DAY AND CYCLE RUN TIME. INCLUDE TARGETED DAILY AND WEEKLY PRECIPITATION RATES FOR EACH ZONE BASED ON CURRENT CLIMATIC CONDITIONS.
2. WATER SHALL BE APPLIED TO MOISTEN THE SOIL APPROPRIATELY FOR THE CURRENT, SEASONAL CLIMATIC CONDITIONS. AVOID OVER-WATERING AND CREATING AREAS OF STANDING WATER OR UNDER WATERING AND CREATING AREAS OF DRY SOIL.
3. IRRIGATION SHALL BE MONITORED WEEKLY TO IDENTIFY AREAS RECEIVING TOO MUCH OR TOO LITTLE PRECIPITATION.
4. SLOPES SHALL BE MONITORED FOR EROSION AND CORRECTIVE ACTION TAKEN IMMEDIATELY.
5. COORDINATE AREAS WHERE IRRIGATION OVERLAPS SODDED AREAS TO ENSURE PROPER SOIL MOISTURE RATES EXIST.
MOWING:
1. MOWING SHALL OCCUR AT INTERVALS OF NOT MORE THAN SEVEN (7) DAYS OR MORE OFTEN IF GROWTH DICTATES.
2. ALL CUTTING EQUIPMENT SHALL BE SHARP AND MOWERS SHALL BE ADJUSTED PRECISELY TO THE PROPER MOWING HEIGHT.
3. MOWING HEIGHTS DURING THE MAINTENANCE PERIOD SHALL BE 2.5-INCH - AT NO POINT SHALL THE HEIGHT OF THE TURF GRASS BE MORE THAN 3.5-INCHES.
4. GRASS CLIPPINGS SHALL BE COLLECTED AND REMOVED FROM THE SITE.
5. COORDINATE IRRIGATION SCHEDULE WITH MOWING SCHEDULE. AT NO TIME SHALL MOWING OCCUR IF SOIL IS WET AND RUTTING MAY OCCUR.
6. EDGES SHALL BE TRIMMED AS NEEDED FOR NEAT APPEARANCE.
WEED CONTROL
1. CONTROL GROWTH OF WEEDS THROUGHOUT MAINTENANCE PERIOD. INSPECT TURF AREAS EVERY SEVEN (7) DAYS FOR WEED GROWTH.
2. UTILIZE 2,4-D BROADLEAF WEED KILLER TO CONTROL WEEDS IN ALL TURF AREAS.
A. FERTILIZATION - TWO REQUIRED APPLICATIONS:
1. TURF MAINTENANCE FERTILIZER: SIMPLOT BEST TURF FOLLOW (22-5-6). SHALL BE APPLIED AT A RATE RECOMMENDED BY MANUFACTURER, DURING START OF TURF MAINTENANCE PERIOD.
2. PLANT MAINTENANCE FERTILIZER: APEX 21-5-6 SHALL BE APPLIED AT A RATE AND FREQUENCY RECOMMENDED BY THE MANUFACTURER FOLLOWING THE START OF THE PLANT MAINTENANCE PERIOD.
B. CONTINUOUSLY MAINTAIN THE ENTIRE PROJECT AREA DURING THE PROGRESS OF WORK UNTIL THE DATE OF SUBSTANTIAL COMPLETION.
FIELD QUALITY CONTROL
A. PERFORM FIELD INSPECTIONS UNDER PROVISIONS OF DIVISION 01 SPECIFICATIONS.
B. COORDINATE FIELD INSPECTIONS WITH OWNER'S REPRESENTATIVE.
C. CONTRACTOR PERFORMED INSPECTIONS: THE CONTRACTOR SHALL PERFORM THE FOLLOWING APPLICABLE INSPECTIONS AND PROVIDE WRITTEN CONFIRMATION OF COMPLETED AND SUCCESSFUL INSTALLATION TO THE ARCHITECT.
1. SOIL AMENDMENTS: PROVIDE REQUIRED PHOTOGRAPHIC DOCUMENTATION DEMONSTRATING SUCCESSFUL PLACEMENT AND TILLING OF SPECIFIED SOIL AMENDMENTS.
2. SOD - TURF STARTER FERTILIZER: PROVIDE REQUIRED PHOTOGRAPHIC DOCUMENTATION DEMONSTRATING SUCCESSFUL PLACEMENT OF TURF STARTER FERTILIZER.
3. TURF MAINTENANCE - MAINTENANCE FERTILIZER: PROVIDE REQUIRED PHOTOGRAPHIC DOCUMENTATION DEMONSTRATING SUCCESSFUL PLACEMENT OF TURF MAINTENANCE FERTILIZER.
D. LANDSCAPE ARCHITECT PERFORMED INSPECTIONS:
1. AMENDS & GRADES TOPSOIL: THE CONTRACTOR SHALL SCHEDULE ONE SITE VISIT WITH THE LANDSCAPE ARCHITECT TO INSPECT TOPSOIL PREPARATION PRIOR TO SOD INSTALLATION. ALL TOPSOIL PLACEMENT, SOIL AMENDMENTS PLACEMENT AND TILLING, COMPACTION/WATER SETTLING AND FINISH GRADING SHALL BE COMPLETED PRIOR TO REQUEST FOR INSPECTION. DO NOT PROCEED WITH SODDING OPERATIONS UNTIL PREPARED TOPSOIL HAS BEEN APPROVED.

CLEANING

- A. AFTER ALL SODDING OPERATIONS HAVE BEEN COMPLETED; REMOVE ALL TRASH, EXCESS SOIL OR RUBBISH FROM THE PROPERTY. ALL SCARS, RUTS OR OTHER MARKS IN THE GROUND CAUSED BY THIS WORK SHALL BE REPAIRED AND THE GROUND LEFT IN A NEAT AND ORDERLY CONDITION THROUGHOUT THE SITE. CONTRACTOR SHALL PICK UP ALL TRASH RESULTING FROM THIS WORK NO LESS FREQUENTLY THAN EACH DAY BEFORE LEAVING THE SITE. ALL TRASH SHALL BE REMOVED COMPLETELY FROM THE SITE. THE CONTRACTOR SHALL LEAVE THE SITE AREA BROOM-CLEAN AND SHALL WASH DOWN ALL PAVED AREAS WITHIN THE CONTRACT AREA, LEAVING THE PREMISES IN A CLEAN CONDITION ACCEPTABLE TO THE ARCHITECT AND CONSTRUCTION MANAGER.

PROTECTION

- A. PROTECT SODDED AREAS WITH WARNING SIGNS UNTIL DATE OF SUBSTANTIAL COMPLETION.



DISCOVERY BIKE PARK
City of Meridian Parks & Recreation
2121 E LAKE HAZEL RD
MERIDIAN, ID 83642

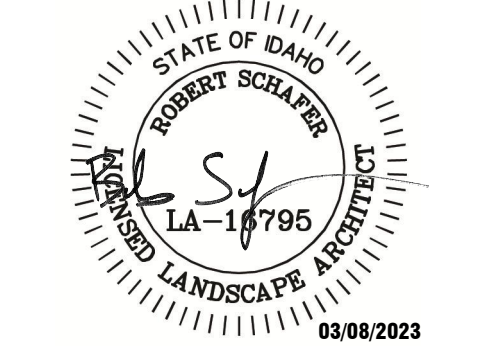

03/08/2023
Project No.: 122129
Date of Issuance: 03/08/2023
Project Milestone: Construction Documents

Landscape Details

L1.50





### IRRIGATION SCHEDULE

SYMBOL	MANUFACTURER/MODEL/DESCRIPTION	PSI	GPM	DETAIL
19	RAIN BIRD 1804-PRS (FOR TURF) ADJ TURF SPRAY 4.0IN. POP-UP SPRINKLER WITH CO-MOLDED WIPER SEAL. 1/2IN. NPT FEMALE THREADED INLET. PRESSURE REGULATING.	30		6/L2.50
20	RAIN BIRD 5004-PL-PC, FC-SAM-R 2.0 TURF ROTOR, 4.0" POP-UP WITH PLASTIC RISER, ADJUSTABLE AND FULL CIRCLE, STANDARD ANGLE NOZZLE, IN-STEM PRESSURE REGULATOR, AND FLOW SHUT-OFF DEVICE. WITH SEAL-A-MATIC CHECK VALVE.	45	2.07	7/L2.50
21	RAIN BIRD 5004-PL-PC, FC-SAM-R 4.0 TURF ROTOR, 4.0" POP-UP WITH PLASTIC RISER, ADJUSTABLE AND FULL CIRCLE, STANDARD ANGLE NOZZLE, IN-STEM PRESSURE REGULATOR, AND FLOW SHUT-OFF DEVICE. WITH SEAL-A-MATIC CHECK VALVE.	45	4.01	7/L2.50
22	RAIN BIRD F4-PC, FC 04 TURF ROTOR, 4.0" POP-UP, PLASTIC RISER, ADJUSTABLE AND FULL CIRCLE WITH REMOVABLE SEAL-A-MATIC CHECK VALVE, 1" FEMALE THREADED INLET.	50	3.7	7/L2.50
23	RAIN BIRD F4-PC, FC 08 TURF ROTOR, 4.0" POP-UP, PLASTIC RISER, ADJUSTABLE AND FULL CIRCLE WITH REMOVABLE SEAL-A-MATIC CHECK VALVE, 1" FEMALE THREADED INLET.	50	7.4	7/L2.50
24	RAIN BIRD PES8-PRS-D 1", 1-1/2", 2" PLASTIC INDUSTRIAL VALVES. LOW FLOW OPERATING CAPABILITY, GLOBE CONFIGURATION, WITH PRESSURE REGULATING MODULE, AND SCRIBBER TECHNOLOGY FOR RELIABLE PERFORMANCE IN DIRTY WATER IRRIGATION APPLICATIONS.			8/L2.50
25	RAIN BIRD 44-RC 1" BRASS QUICK-COUPLING VALVE, WITH CORROSION-RESISTANT STAINLESS STEEL SPRING, THERMOPLASTIC RUBBER COVER, AND 2-PIECE BODY.			5/L2.50
26	ISOLATION VALVE			3/L2.50
27	ISOLATION VALVE   SUBMAINLINE MATCO-NORICA S14TX, 1-1/2" BRASS GATE VALVE, FULL PORT, WITH SOLID WEDGE, IPS, CROSS HANDLE. INSTALL IN 12" ROUND VALVE BOX.			4/L2.50
28	DRAIN VALVE			3/L2.50
29	POINT OF CONNECTION POINT OF CONNECTION AT 6-IN PRRR STUB			
30	IRRIGATION LATERAL LINE: PVC CLASS 200 SDR 21 PVC CLASS 200 PIPE SHALL BE USED WITH DUCTILE IRON JOINT RESTRAIN FITTINGS BY LEEMCO FOR ALL PIPE SIZED 3" AND LARGER. ALL PIPE 2-1/2" AND BELOW SHALL BE CLASS 200 PVC WITH SOLVENT WELD SCH. 40 FITTINGS.			1/L2.50
31	IRRIGATION MAINLINE: PVC CLASS 200 SDR 21 VC CLASS 200 PIPE SHALL BE USED WITH DUCTILE IRON JOINT RESTRAIN FITTINGS BY LEEMCO FOR ALL PIPE SIZED 3" AND LARGER. ALL PIPE 2-1/2" AND BELOW SHALL BE CLASS 200 PVC WITH SOLVENT WELD SCH. 40 FITTINGS.			1/L2.50
32	PIPE SLEEVE: PVC CLASS 200 SDR 21 PIPE SLEEVE SHALL BE TWICE THE SIZE OF DESIGNED PIPE DIAMETER FOR MAINLINE AND 4" FOR LATERAL LINES. INSTALL ADDITIONAL 2" SLEEVE AT ALL MAINLINE SLEEVES FOR CONTROL WIRES OR WHERE CONTROL WIRE LEAVES MAINLINE ROUTE.			2/L2.50



**Sheet Notes:**

- CONTRACTOR TO VERIFY LOCATION OF ALL UTILITIES PRIOR TO INITIATION OF ANY DEMOLITION OR CONSTRUCTION OPERATIONS. ANY DAMAGE TO EXISTING UTILITIES SHALL BE CONTRACTOR'S RESPONSIBILITY.
- IN THE EVENT OF A DISCREPANCY, NOTIFY THE LANDSCAPE ARCHITECT IMMEDIATELY.
- SEE SHEET L2.50 FOR IRRIGATION DETAILS AND NOTES.

**Keynotes:**

- FIELD LOCATE 6-IN PRESSURE IRRIGATION MAIN LINE STUB AND IRRIGATION TWO-WIRE AT THIS LOCATION. CONNECT MAIN LINE WATER TIGHT AND SPLICE ONTO TWO-WIRE DOWNSTREAM PER PLANS. SEE IRRIGATION NOTES NOTE A ON SHEET L2.50.



**Irrigation Plan**  
Horizontal Scale: 1" = 30'

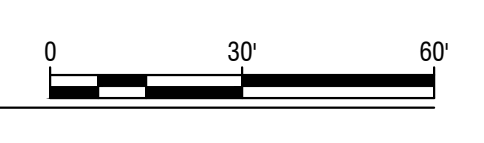

**DISCOVERY BIKE PARK**  
City of Meridian Parks & Recreation

2121 E LAKE HAZEL RD  
MERIDIAN, ID 83642

Revisions:

1.	

03/08/2023

Project No.: 122129  
Date of Issuance: 03/08/2023  
Project Milestone: Construction Documents



**Irrigation Notes:**

- A. REFER TO THE DISCOVERY PARK PHASE 2 PLAN SHEET DRAWINGS FOR MORE INFORMATION REGARDING APPROXIMATE IRRIGATION MAIN LINE AND WIRING LOCATIONS.
- B. SYSTEM DESIGN BASED ON THE ASSUMPTION OF THE AVAILABILITY OF 400 G.P.M. AND 80 P.S.I. AT THE POINT OF CONNECTION.
- C. CONTRACTOR TO VERIFY LOCATION OF ALL UTILITIES PRIOR TO INITIATION OF ANY DEMOLITION OR CONSTRUCTION OPERATIONS. ANY DAMAGE TO EXISTING UTILITIES SHALL BE CONTRACTOR'S RESPONSIBILITY.
- D. COORDINATE ALL IRRIGATION INSTALLATION OPERATIONS WITH CIVIL, MECHANICAL AND ELECTRICAL ENGINEERING SHEETS.
- E. CONTRACTOR TO COORDINATE INSTALLATION OF IRRIGATION CONDUIT AND SLEEVES UNDER HARD SURFACES WITH RESPECTIVE CONTRACTORS.
- F. ALL SLEEVES TO BE INSTALLED AS PART OF IRRIGATION CONTRACT. APPROXIMATE LOCATION OF SLEEVES ARE SHOWN ON THE IRRIGATION PLAN. FIELD VERIFY LOCATION. ALL ENDS OF SLEEVES TO BE TAPED OR CAPPED AND MARKED WITH A 2" x 4" PAINTED STAKE EXTENDING TO 24" ABOVE GRADE. STAKES ARE NOT TO BE REMOVED UNTIL THE IRRIGATION SYSTEM IS COMPLETE. ALL SLEEVES SHALL EXTEND A MINIMUM OF 18" BEYOND BACK OF CURB OR EDGE OF PAVEMENT. PROVIDE COMPACTED BACKFILL.
- G. CONTRACTOR TO OBTAIN AND PAY FOR ALL PERMITS AND FEES REQUIRED FOR THIS WORK.
- H. IRRIGATION CONTROLLER(S) ARE EXISTING AND SHALL BE RETAINED AND PROTECTED. COORDINATE IMPROVEMENTS SHOWN ON THESE PLANS WITH SAID CONTROLLER(S). ANY NEW WIRE SHALL MATCH EXISTING IN TYPE.
- I. IRRIGATED AREAS CONTAINING VEGETATION WHICH POTENTIALLY MAY IMPED E PERFORMANCE OF A POP-UP SPRINKLER AND/OR ROTOR HEADS ARE TO BE REPLACED WITH A 12" HIGH POP-UP HEADS.
- J. ALL ELECTRICAL WORK TO MEET OR EXCEED N.E.C., STATE CODES, LOCAL CODES, AND MANUFACTURER'S RECOMMENDATIONS.
- K. CONTRACTOR SHALL REMOVE AND DISPOSE OF ALL ROCK AND DEBRIS BROUGHT TO THE SURFACE AS A RESULT OF TRENCHING OPERATIONS.
- L. CONTRACTOR SHALL REFER TO SPECIFICATIONS AND DETAIL DRAWINGS FOR ADDITIONAL REQUIREMENTS.
- M. ALL 24 VOLT POWER WIRES SHALL BE #14 AWG COPPER. ALL ABOVE GROUND 120 VOLT AND 24 VOLT WIRE SHALL BE IN PVC CONDUIT. ALL 24 VOLT WIRES SHALL BE TAPED TOGETHER AT TEN FOOT (10'-0") INTERVALS.
- N. INSTALLATION SHALL COMPLY WITH ALL NATIONAL, STATE, AND LOCAL LAWS AND ORDINANCES.
- O. IRRIGATION CONTRACTOR SHALL PROVIDE AN AS-BUILT IRRIGATION PLAN UPON COMPLETION OF INSTALLATION AND PRIOR TO FINAL PAYMENT.
- P. THE ENTIRE SYSTEM SHALL BE GUARANTEED TO BE COMPLETE AND PERFECT IN EVERY DETAIL FOR A PERIOD OF ONE YEAR FROM THE DATE OF ITS ACCEPTANCE; REPAIR OR REPLACEMENT OF ANY DEFECTS OCCURRING WITHIN THAT YEAR SHALL BE FREE OF EXPENSE TO THE OWNER.
- Q. AS PART OF THIS CONTRACT, PERFORM AT NO EXTRA COST WINTERIZATION AND SPRING START UP OF THE SYSTEM DURING THE GUARANTEE PERIOD.
- R. ALL MATERIALS SHALL BE NEW AND WITHOUT FLAWS OR DEFECTS OF THE QUALITY AND PERFORMANCE SPECIFIED, AND SHALL MEET THE REQUIREMENTS OF THIS SYSTEM. USE MATERIALS AS SPECIFIED. NO SUBSTITUTIONS SHALL BE PERMITTED WITHOUT PRIOR WRITTEN PERMISSION OF THE OWNER.
- S. IRRIGATION CONTRACTOR SHALL MAKE NECESSARY MINOR FIELD ADJUSTMENTS TO SPRINKLER NOZZLES, SPRINKLERS, PIPE, AND OTHER IRRIGATION EQUIPMENT LOCATIONS TO FIT THE AS-BUILT SITE. ADJUST HEAD AND PIPE LOCATIONS AS REQUIRED TO AVOID DAMAGING EXISTING TREE ROOTS. ADJUSTMENTS SHALL ENSURE HEAD TO HEAD COVERAGE.
- T. IRRIGATION PIPING LAYOUT IS SCHEMATIC. WHERE LINES ARE SHOWN BELOW PAVEMENT ADJACENT TO LANDSCAPE AREAS, THEY ARE TO BE LOCATED IN THE LANDSCAPE AREA UNLESS SHOWN WITH A SLEEVE SYMBOL.
- T.A. IRRIGATION MAINLINE SHALL BE SLEEVED UNDER ALL HARDSCAPE. SLEEVING MAY NOT BE SHOWN FOR MAINLINE FOR GRAPHICAL PURPOSES.
- U. LOCATION OF EXISTING EQUIPMENT ARE SCHEMATIC IN NATURE. FIELD VERIFY ALL BASE AND EXISTING IRRIGATION ELEMENTS AND CONDITIONS PRIOR TO CONSTRUCTION AND PROVIDE NECESSARY ADJUSTMENTS.
- V. IN THE EVENT OF A DISCREPANCY, IMMEDIATELY NOTIFY THE LANDSCAPE ARCHITECT.
- W. CONTRACTOR SHALL SCHEDULE A MEETING WITH LANDSCAPE ARCHITECT AND OWNERS REPRESENTATIVE PRIOR TO INSTALLATION OF IRRIGATION CONTROL SYSTEM TO DETERMINE PROCEDURES OF INSTALLATION OF IRRIGATION CONTROL SYSTEM.
- X. PIPE VELOCITIES SHALL NOT EXCEED 5 FT/SEC.
- Y. AREAS WHERE FULL CIRCLE HEADS ARE REQUIRED, NON-REVERSING CIRCLE HEADS SHALL BE INSTALLED. PARTIAL CIRCLE HEADS WITH REVERSING DIRECTION ARE PROHIBITED FOR USE OF 360° ROTATION.
- Z. ALL MAIN LINE FITTINGS SHALL BE LEEMCO DUCTILE IRON PUSH ON TYPE AND ARE TO BE JOINED USING LEEMCO JOINT RESTRAINT SYSTEMS. INSTALL PER MANUFACTURER'S RECOMMENDATIONS.
- AA. PROVIDE AND INSTALL GROUNDING ALONG THE TWO WIRE PATH PER MANUFACTURER'S RECOMMENDATIONS.

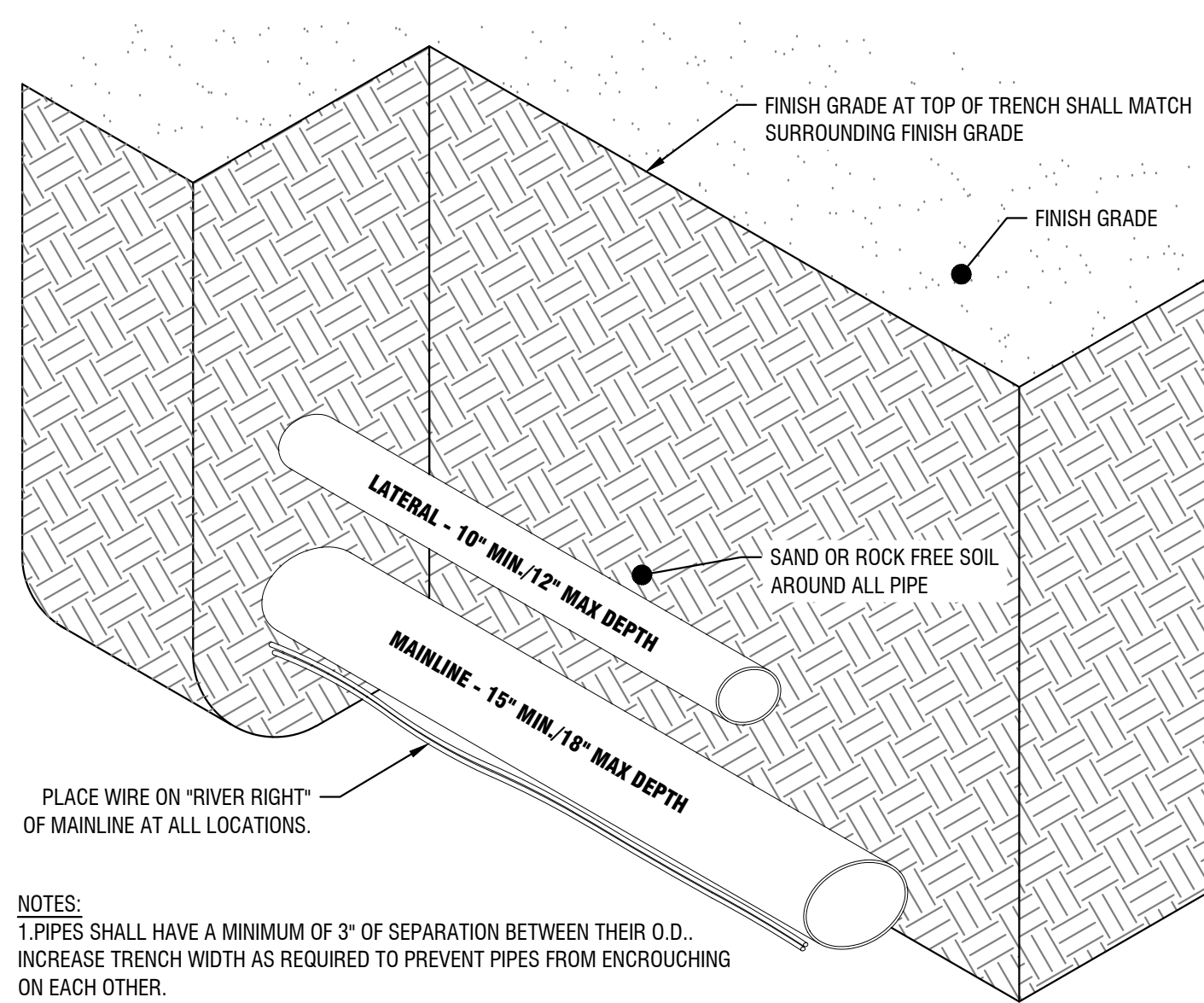

**1 TRENCH SECTION**  
SCALE: NTS

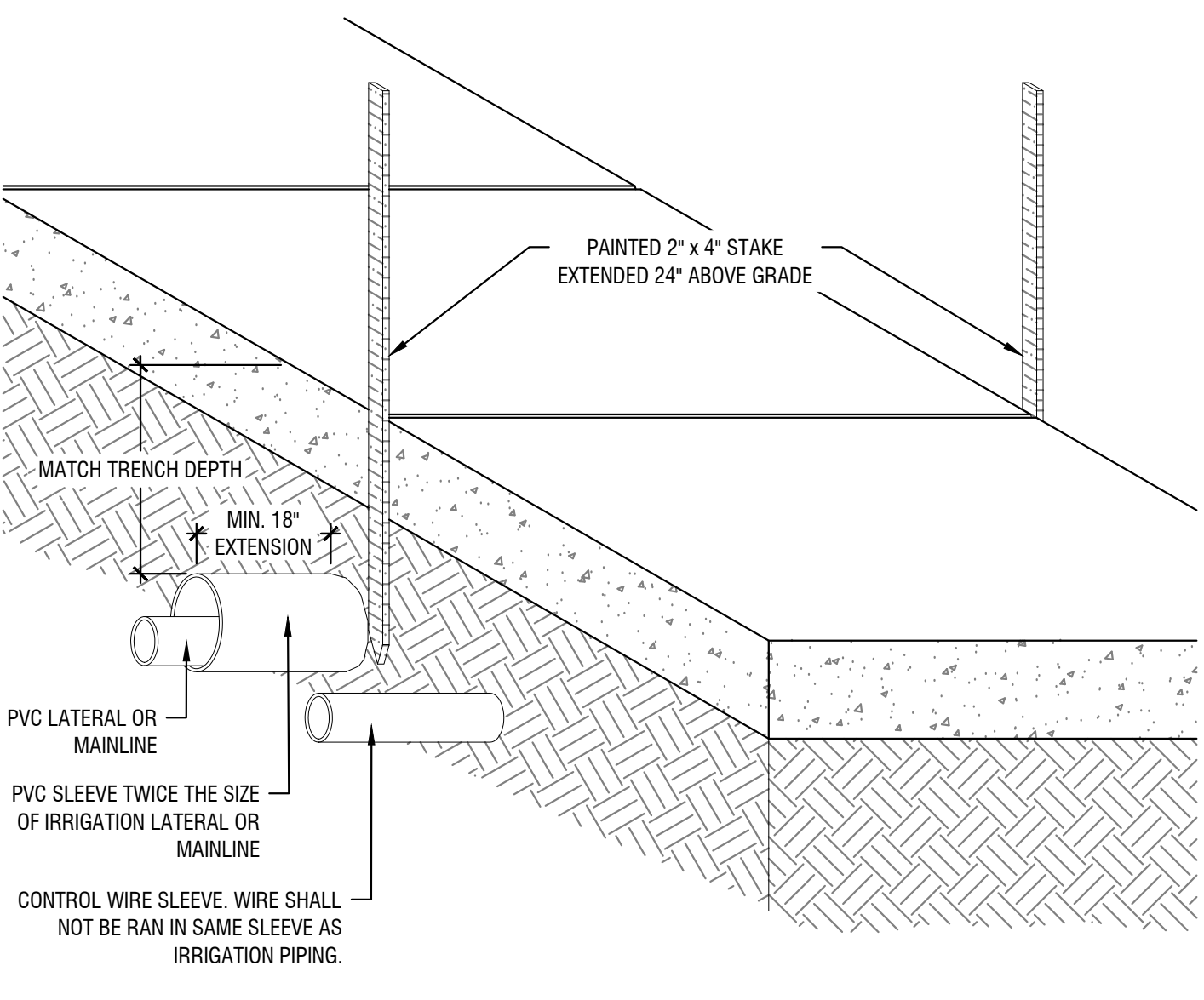

**2 SLEEVING SECTION**  
SCALE: NTS

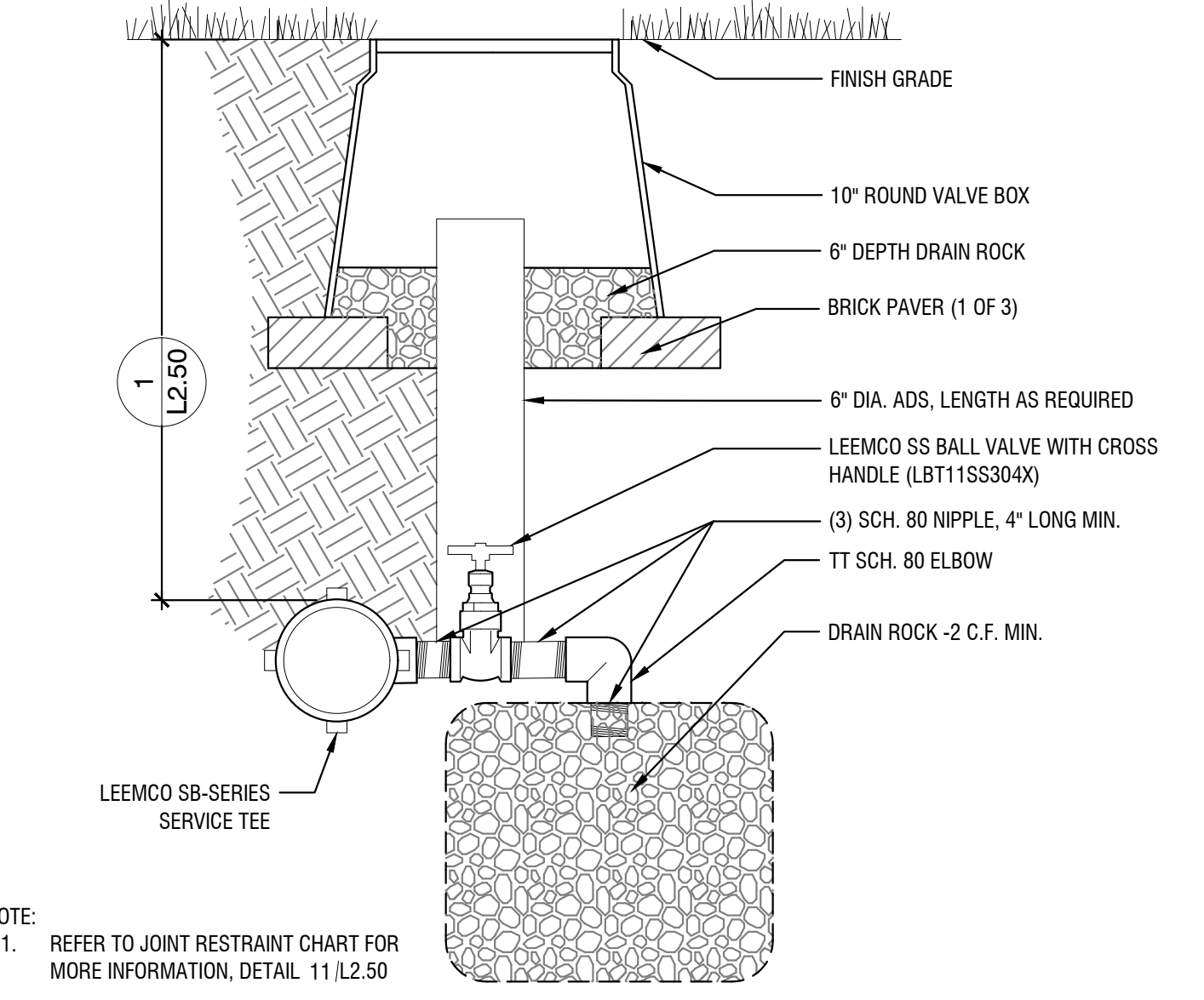

**3 MANUAL DRAIN VALVE**  
SCALE: NTS

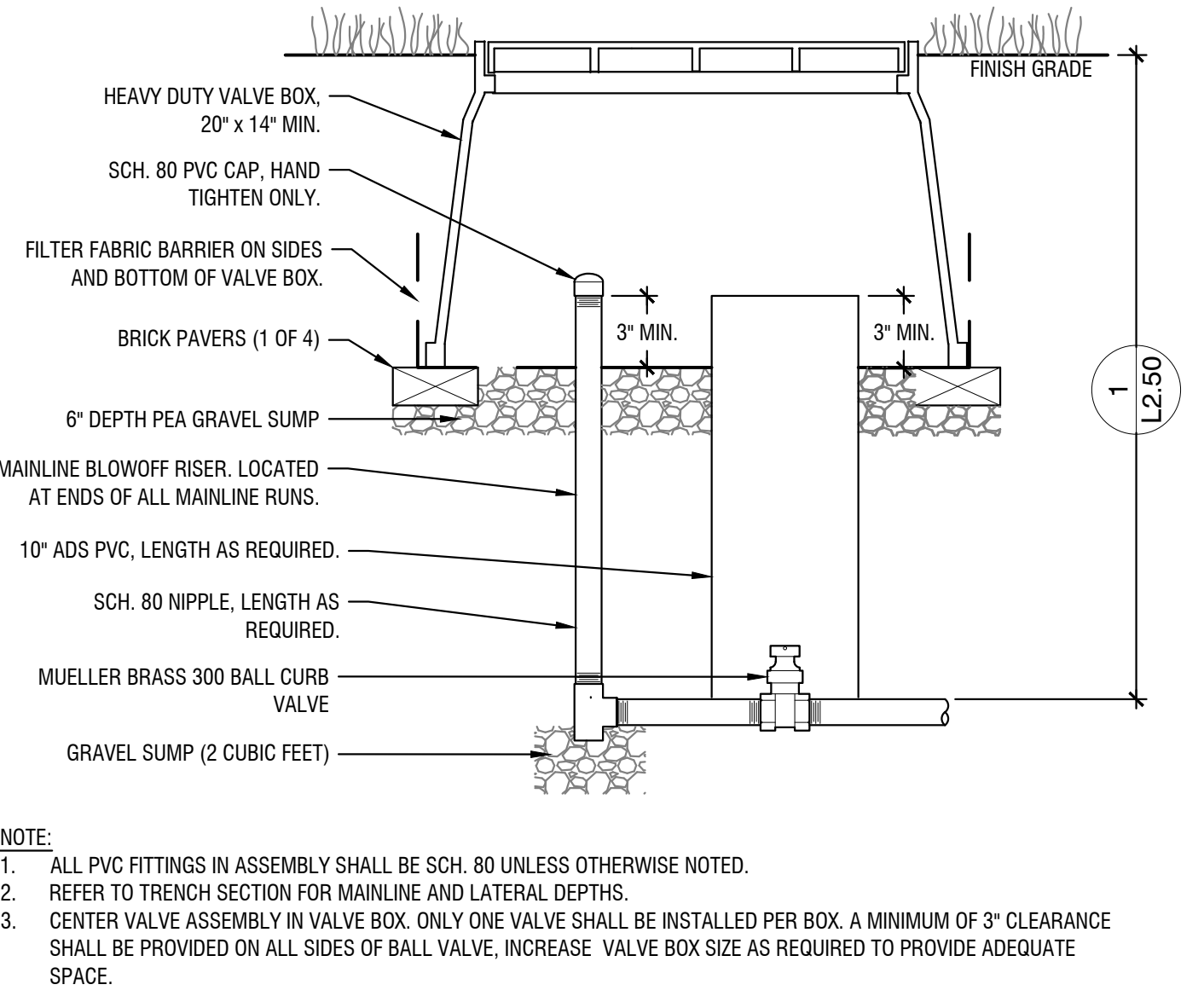

**4 SUB-MAINLINE ISOLATION VALVE**  
SCALE: NTS

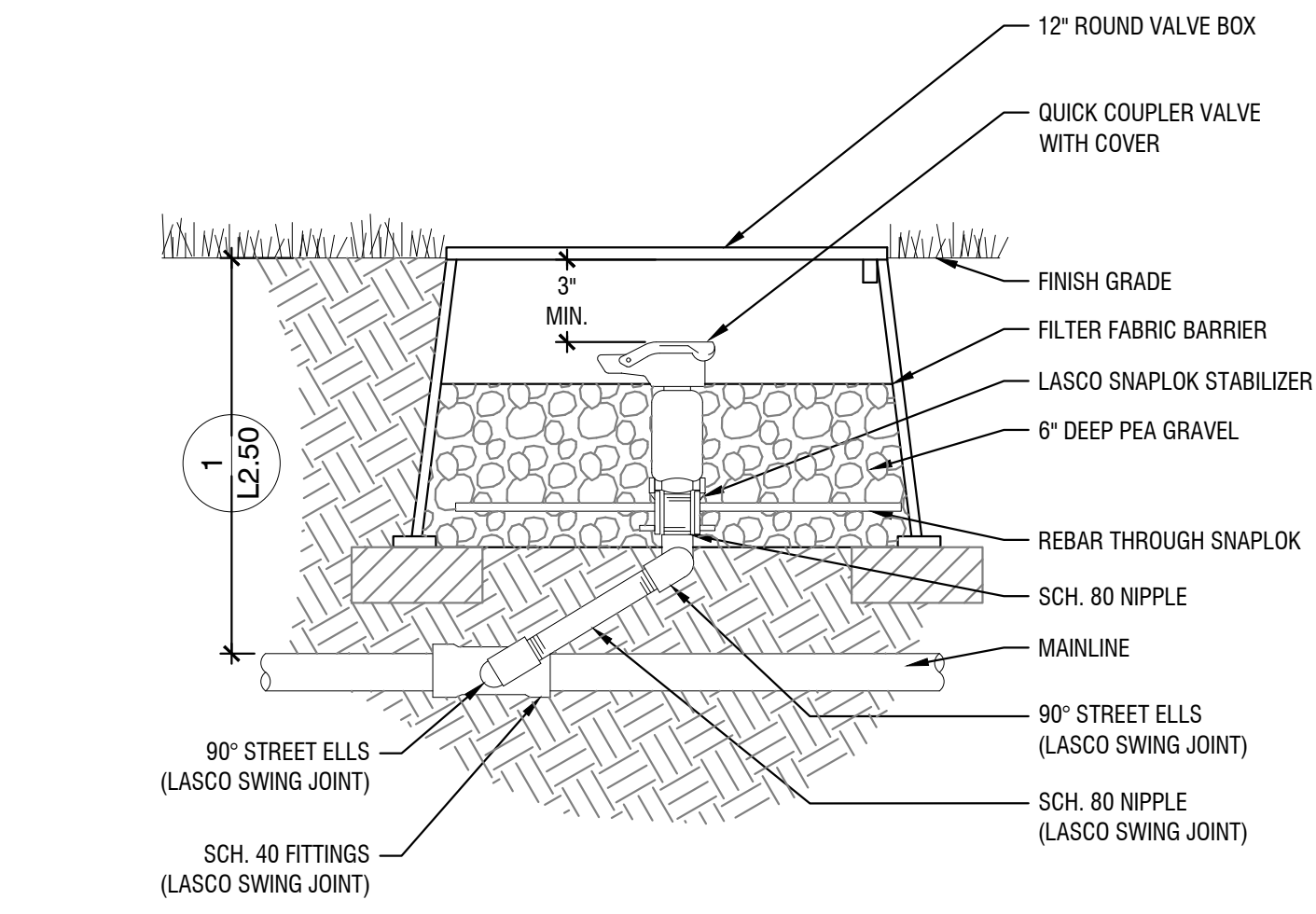

**5 QUICK COUPLER VALVE**  
SCALE: NTS

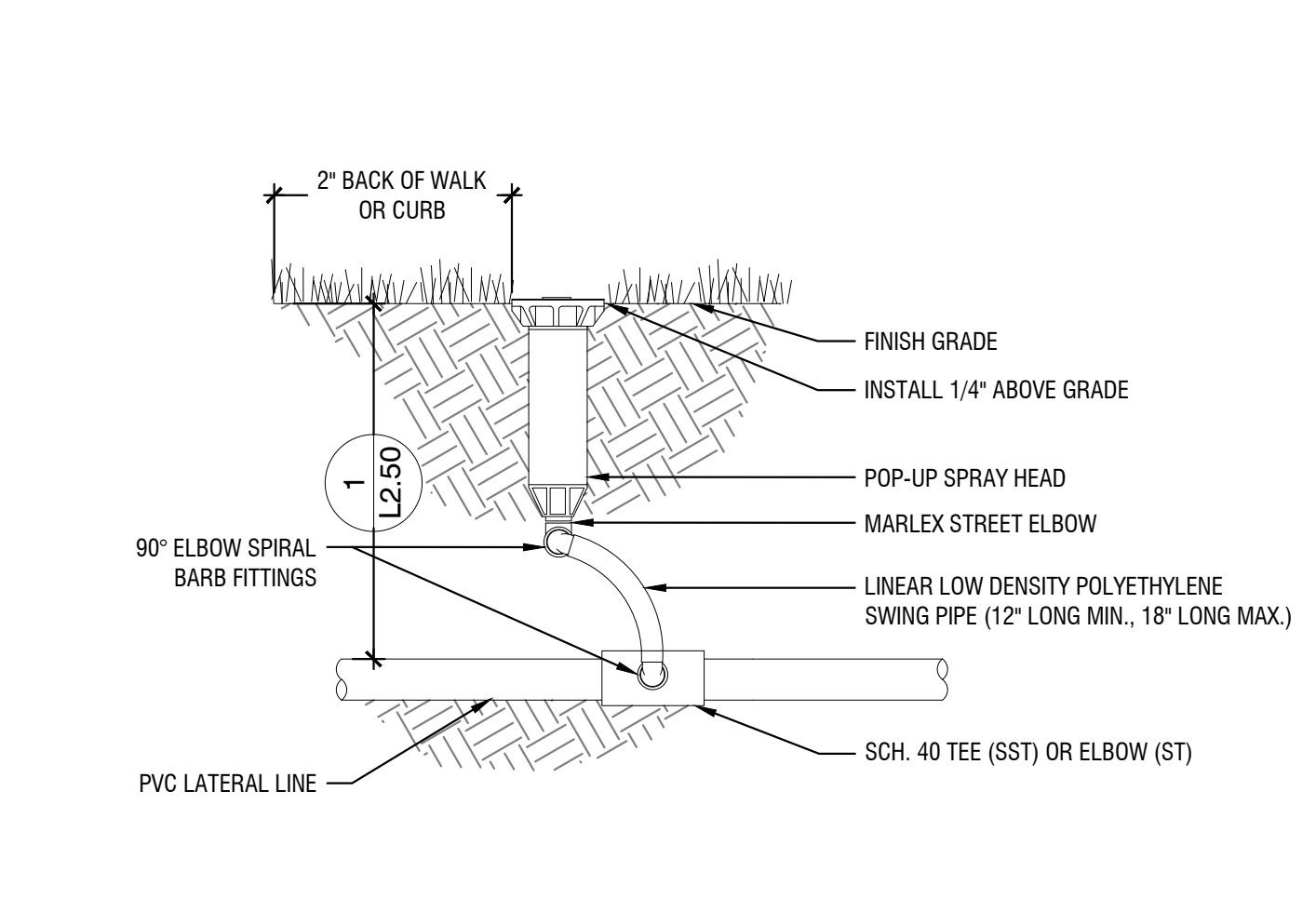

**6 SPRAY HEAD SPRINKLER**  
SCALE: NTS

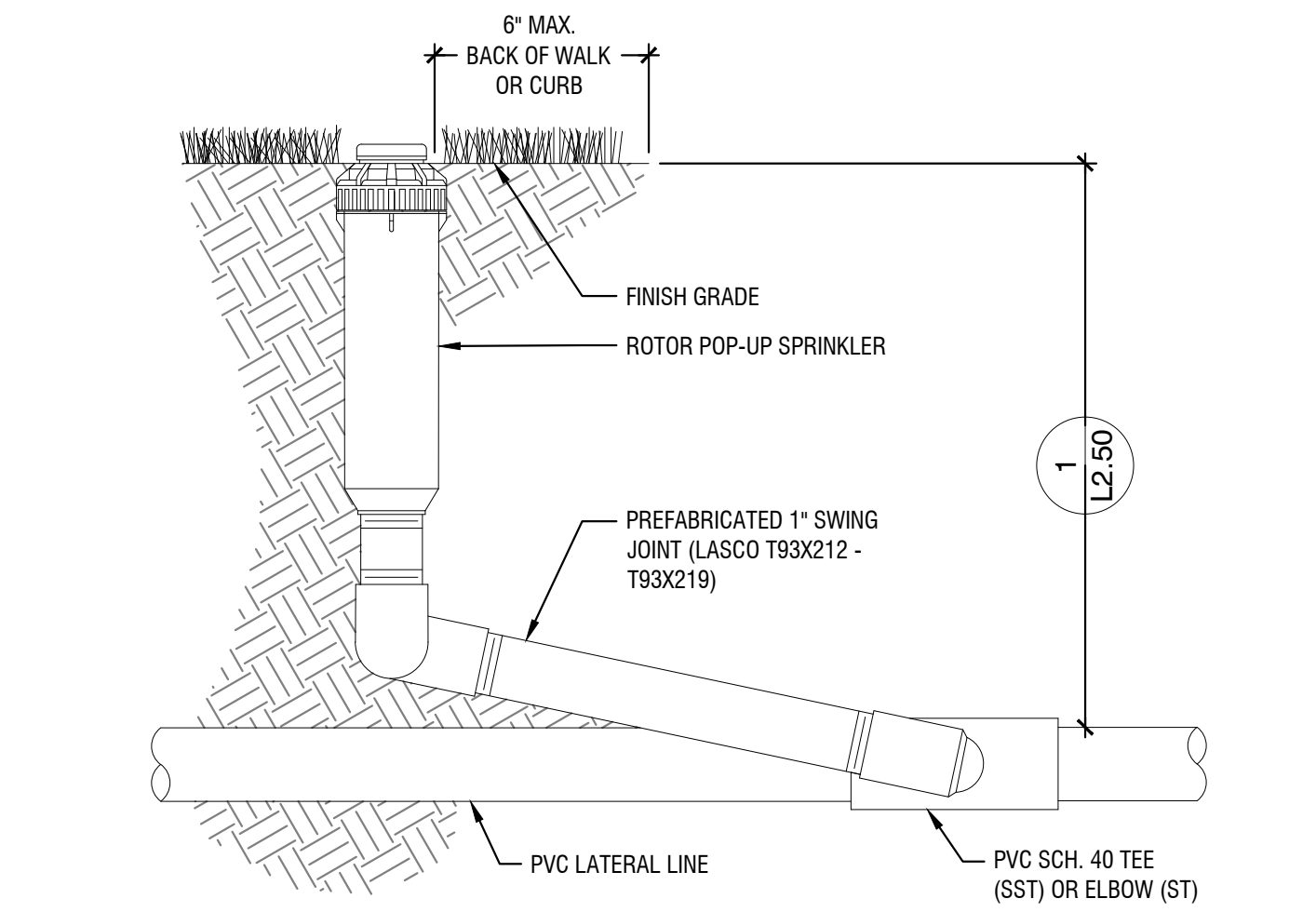

**7 ROTOR SPRINKLER**  
SCALE: NTS

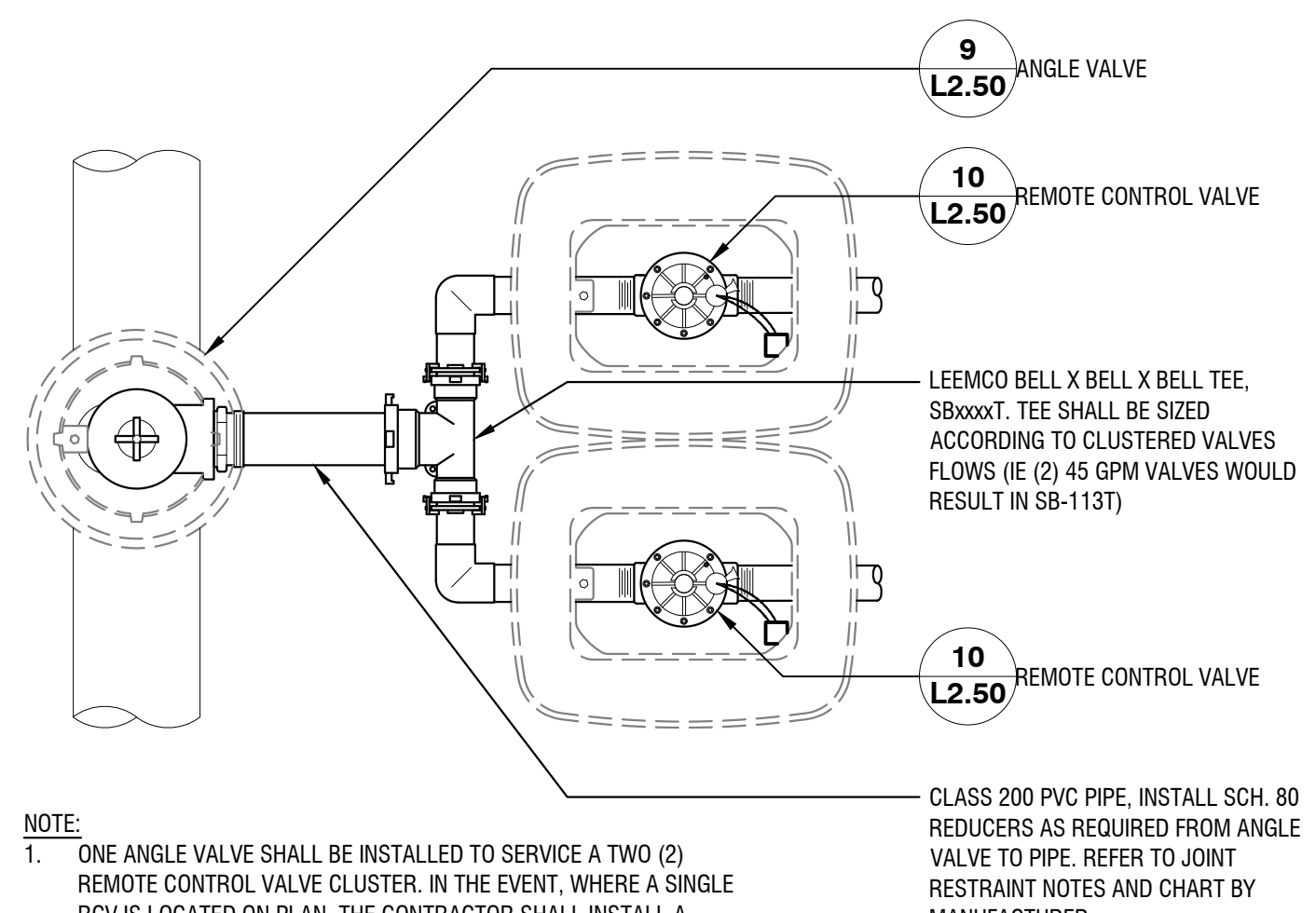

**8 REMOTE CONTROL VALVE - LAYOUT**  
SCALE: NTS

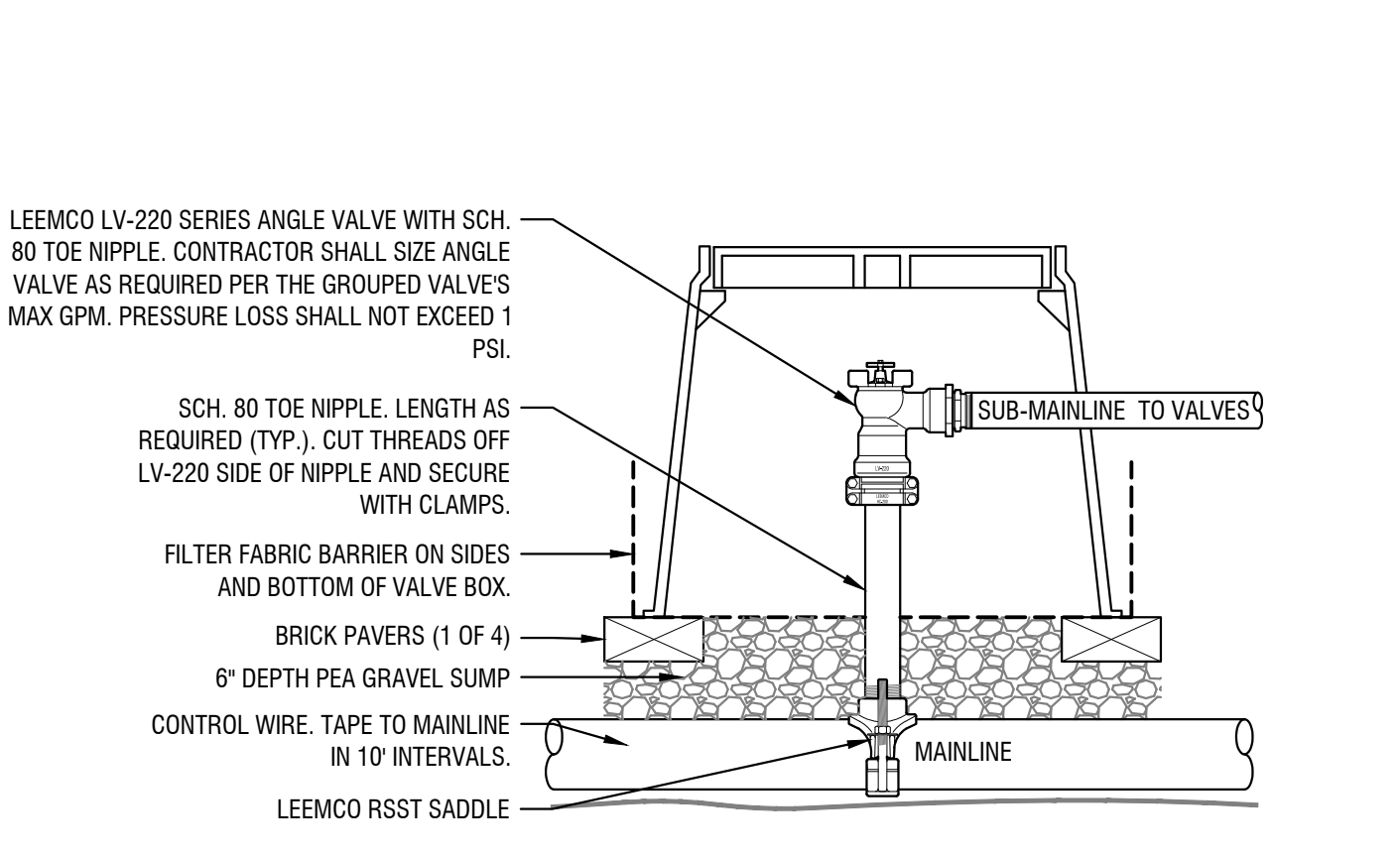

**9 REMOTE CONTROL VALVE - ANGLE VALVE**  
SCALE: NTS

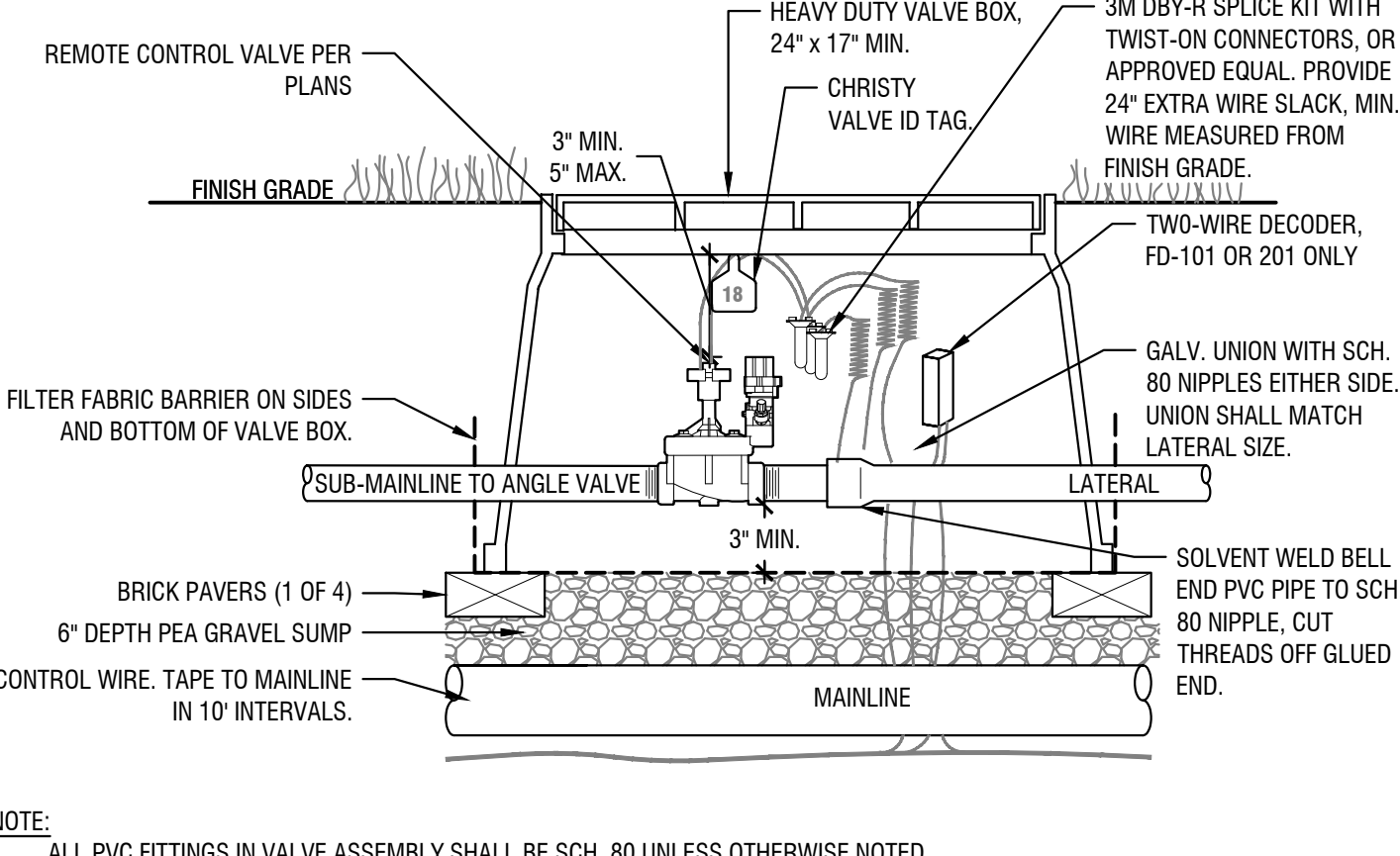

**10 REMOTE CONTROL VALVE - VALVE SECTION**  
SCALE: NTS

**DISTANCE CHART**  
REFER TO THE FOLLOWING TABLE THAT LISTS THE LENGTH (IN FEET) FOR EACH SIZE/TYPE FITTING WITHIN WHICH ALL JOINTS JUST BE RESTRAINED. ALL FITTINGS AND JOINT RESTRAINTS SHALL BE INSTALLED PER MANUFACTURER'S RECOMMENDATIONS & SPECIFICATIONS.

AS AN EXAMPLE, IF YOU ARE INSTALLING A 3" MAINLINE WITH A DIRECTIONAL CHANGE OF 90°. REFER TO CHART UNDER PIPE SIZE TO 3" AND UNDER BENDS 90 YOU WILL SEE THE DISTANCE OF 11'. IF THERE IS ANY JOINT (VALVE, BELL, ETC.) YOU MUST INSTALL A JOINT RESTRAINT WITHIN 11' OF THE 90° MAINLINE DIRECTIONAL CHANGE.

PIPE SIZE	BENDS				REDUCERS			DEAD END	
	11°	22°	45°	90°	1 STEP	2 STEP	3 STEP	BLIND	SERV. B.
2"	1'	1'	2'	6'	-	-	-	19'	6'
2.5"	1'	2'	4'	9'	4'	-	-	23'	10'
3"	2'	3'	6'	11'	8'	10'	-	30'	15'
4"	2'	4'	9'	20'	14'	20'	31'	45'	25'
6"	3'	6'	13'	29'	30'	40'	53'	63'	40'
8"	4'	8'	15'	38'	33'	55'	63'	75'	70'
10"	5'	9'	19'	45'	38'	58'	75'	96'	90'
12"	5'	10'	21'	53'	38'	60'	83'	112'	110'

**INSTALLATION CHART**  
REFER TO THE TABLE TO THE RIGHT WHICH LISTS THE NUMBER OF BOLTS, SIZE, AND TORQUE FOR EACH BOLT IN REFERENCE TO THE SIZE OF PIPE WHICH IS BEING RESTRAINED.

AS AN EXAMPLE, IF YOU HAVE A 3" PIPE, YOU WILL NEED 2 BOLTS THAT ARE 3/8 x 2.5" AND TIGHTEN THEM WITH A TORQUE WRENCH TO 20 FT-LBS.

PIPE SIZE	NO. BOLTS	BOLT SIZE	TORQUE FT-LBS
2"	2	3/8" x 2-3/8"	20
2.5"	2	3/8" x 2-3/8"	20
3"	2	3/8" x 2-3/8"	20
4"	2	1/2" x 3"	50
6"	2	1/2" x 3-1/2"	50
8"	4	1/2" x 4"	50
10"	4	3/4" x 5-1/2"	100
12"	4	3/4" x 5-1/2"	100

**11 JOINT RESTRAINT CHART**  
SCALE: NTS

**Existing Irrigation Retention and Preservation:**

- A. CONTRACTOR SHALL FIELD LOCATE ALL EXISTING IRRIGATION MAINLINE, LATERALS AND ASSOCIATED COMPONENTS THAT ARE IN NEAR VICINITY OF CONSTRUCTION LIMITS. CONTRACTOR SHALL RETAIN AND PROTECT ALL EXISTING EQUIPMENT AND PIPING THROUGHOUT THE DURATION OF CONSTRUCTION.
- B. CONTRACTOR SHALL ENSURE 100% FUNCTIONALITY OF EXISTING SYSTEM DURING AND AFTER CONSTRUCTION.
- C. CONTRACTOR SHALL REPLACE/REPAIR ANY DAMAGED EXISTING PIPING AND/OR COMPONENTS AT NO COST TO OWNER.

**Irrigation Execution:**

- A. REMOTE CONTROL VALVES:
  - A.A. INSTALLED (1) REMOTE CONTROL VALVE PER VALVE BOX. ENSURE THAT ADEQUATE SPACE IS PROVIDED AROUND ENTIRE VALVE FOR EASE OF MAINTENANCE. ROUND VALVE BODIES ARE NOT PERMITTED.
  - A.B. VALVE BOXES SHALL BE GREEN OR BLACK WITH GREEN LIDS.
- B. IRRIGATION CONTROL WIRE:
  - B.A. ALL WIRE SPLICES SHALL BE INSTALLED WITH A WATERPROOF WIRE CONNECTORS AND DRYER CAP OR BLAZING NUT WIRE SPLICE CONNECTOR.
  - B.B. ALL WIRE SPLICES SHALL BE LOCATED IN VALVE BOXES AND INDICATED ON AS-BUILT DRAWINGS. PROVIDE AS A MINIMUM, 36" OF EXTRA WIRE AT ALL WIRE SPLICES AND REMOTE CONTROL VALVE CONNECTIONS.
  - B.C. CONTROL WIRE SHALL BE INSTALLED WITH PROPOSED MAINLINE. IF CONTROL WIRE LEAVES PIPING TRENCH, WIRE SHALL BE INSTALLED AT A MINIMUM DEPTH OF 12".
- C. PIPING (USE THE FOLLOWING):
  - C.A. 2-1/2" AND SMALLER | SDR 21 SCH. 40 PVC. SOLVENT-CEMENT JOINTS.
  - C.B. 3" AND LARGER | SDR 26 CLASS 200 RUBBER GASKETED PVC WITH DUCTILE IRON JOINT RESTRAINT SYSTEM, LEEMCO OR APPROVED EQUAL.
  - C.C. TRENCHES SHALL BE PHOTO DOCUMENTED AND SUBMITTED ARCHITECT PRIOR TO BACKFILLING.
  - C.D. BACKFILL TRENCHES CONSISTING OF SAND, FINE GRAVEL OR SELECT EARTH FREE OF LARGE LUMPS OR ROCKS LARGER THAN 3/4" SHALL BE USED IN AND AROUND INSTALLED PIPE.

