

# **Ecological No Net Loss Assessment Report**

Prepared for

**Jain Residence  
8315 Overlake Drive West  
Medina, WA 98039**

Prepared by

 **Northwest**  
Environmental Consulting, LLC

Northwest Environmental Consulting, LLC  
600 North 36<sup>th</sup> Street, Suite 423  
Seattle, WA 98103  
206-234-2520

**January 2024**

## Purpose

The purpose of this report is to fulfill the requirements of City of Medina Municipal Code (MMC) 20.66.000 for General requirements applicable to all shoreline development and uses by assessing overall project impacts and proposed mitigation to determine if the project meets the “No Net Loss” standard.

No Net Loss is defined as “An ecological concept whereby conservation losses in one geographic or otherwise defined area are equaled by conservation gains in function in another area.”

Permits are being applied for a moorage cover.

## Location

The subject property is located at 8315 Overlake Drive West in the City of Medina, Washington (see Appendix A – Sheet 1.0). The parcel is on the waterfront of Lake Washington, a shoreline of the state, that contains several endangered fish species listed under the Endangered Species Act and Washington State designated priority fish species.

## Project Description

The proposed work will install a translucent, Crystallite, moorage cover.

During construction, a floating boom will surround the work barge and dock. (See Appendix A – Sheet 7.0).

A shoreline vegetation plan is proposed, that will add 2 native conifers and 3 native shrubs. These shoreline plantings will provide shade and allow beneficial allochthonous material to enter the lake along the shoreline. The existing vegetation will be preserved. (See Appendix A – Sheet 8 and 9).

Project drawings are included in Attachment A.

## Approach

Northwest Environmental Consulting LLC (NVEC) biologist Brad Thiele conducted a site visit on December 21, 2023 to evaluate conditions on site and adjacent to the site. NVEC also consulted the following sources for information on potential critical fish and wildlife habitat along this shoreline:

- Washington Department of Fish and Wildlife (WDFW): Priority Habitats and Species online database (<http://apps.wdfw.wa.gov/phsontheweb/>)
- WDFW SalmonScope online database of fish distribution and ESA listing units (<https://apps.wdfw.wa.gov/salmonscape/>)

## Site Description

The subject property is a shoreline tract in a residential neighborhood. It has shoreline on its western boundary with single-family homes to the north and south along the shoreline.

The only existing structures on the property are the house and dock. The dock has been upgraded with grated decking.

The shoreline is lawn with some ornamental shrubs and fruit trees to a concrete walkway. The walkway borders a gravel beach and has an attached concrete patio that extends landward. The walkway appears to be waterward of the ordinary high water mark. The substrates along the shore are gravel changing to sand about 10 feet from shore. Eurasian milfoil was present starting about 40 feet from shore.

The neighboring shorelines are landscaped similarly with docks and no bulkheads. See attached photos in Appendix B- Photos.

## Species Use

WDFW's PHS mapping and SalmonScape mapping tools show the following salmonid species using Lake Washington for migration and/or rearing: residential coastal cutthroat (*Oncorhynchus clarkii*), winter steelhead (*O. mykiss*), Dolly Varden/bull trout (*Salvelinus malma*), sockeye salmon (*O. nerka*), fall Chinook (*O. tshawytscha*), coho salmon (*O. kisutch*), and kokanee (*O. nerka*). The SalmonScape database maps the site as accessible to the Endangered Species Units (ESU) of Threatened Chinook and steelhead. Juveniles migrate and may rear in the waters near the project when traveling from spawning sites on other lake tributaries to the lakes system's outlet at the Hiram M. Chittenden Locks. The project site is accessible to any fish migrating or rearing in the lake.

The shoreline is not mapped as a Sockeye spawning location, sockeye spawning is mapped south of the property near the point.

Priority Habitats and Species mapping, maps a wetland about 300 feet to the west of the project.

## Project Impacts and Conservation Measurements

### **Direct Impacts:**

**Sediments:** Sediment disturbance will not occur from installing a moorage cover.

**Shoreline:** Planting native vegetation, including a Douglas fir, shore pine and native shrubs, will increase the habitat functions of the shoreline by creating shade along the shoreline that will be an improvement from the existing baseline habitat conditions at the project site. These plants will provide overhanging cover for fish, structural diversity for birds and wildlife, detritus for aquatic invertebrates and long-term recruitment of woody material and other allochthonous food sources. The proposed planting plan is included (see Appendix A – Sheet 8).

**Lakebed:** No change to lakebed will occur from installation of a translucent moorage cover.

**Noise:** Construction equipment will create noise audible to neighbors. Noise disturbance will be short-term and should have negligible effects on fish and wildlife in the area. Work will be

completed during the in-water work window when juvenile fish are not expected to be present in larger numbers.

**Potential spills:** Short-term risks include the potential for spills that can occur with any equipment operation. The risk of impact to the aquatic environment is expected to be minimized because a trained crew will be onsite that will implement spill containment measures should a spill occur.

**Shading:** Shading of the water column is a concern in the nearshore and can create habitat for predatory fish that feed on outmigrating salmonids. Overwater coverage may also create a partial migration barrier to juvenile salmonids that may hesitate before passing underneath a structure increasing outmigration times. Using a transparent moorage cover will minimize this effect.

**Recreational Boating:** The project supports continued recreational boating, which has been identified as a limiting factor for salmonid populations in Lake Washington. The moorage improvements will not introduce additional boating to Lake Washington, as the owners could still access the lake from a public boat launch or private moorage facility.

***Other Conservation measures:***

**Work window:** The work will be completed during the prescribed in-water work window for this area of Lake Washington (July 16 to March 15). Operating within this time frame helps protect Chinook salmon, steelhead, bull trout and other salmonid fish species by doing work when juvenile fish are not expected to be present that use the nearshore environment where the work occurs.

**Best Management Practices:** Applicable BMPs will be used, such as a floating boom around the in-water work area, to contain any floating debris that may escape during construction. The barge will have a perimeter containment sock to absorb oil and grease that might inadvertently wash from the barge during construction.

Hazardous material containment supplies such as spill absorbent pads and trained personnel will be required onsite during any phase of construction where machinery is in operation near surface waters.

**In-lieu Fee:** The shoreline on the subject property will be planted with native, overhanging vegetation. The project also requires approval from the National Marine Fisheries Service (NMFS). NMFS has developed a calculator to determine appropriate mitigation costs for proposed in-water structures in Lake Washington. This calculator has established a fund that owners can pay into if they are not willing or cannot find mitigation to offset impacts from the project. The owner is not able to complete the required mitigation at the subject property required by NMFS and the property owners will pay into the in-lieu fee program to mitigate project impacts. An in-lieu fee program is defined as follows:

“A program involving the restoration, establishment, enhancement, and/or preservation of aquatic resources through funds paid to a governmental or non-profit natural resources management entity to satisfy compensatory mitigation requirements... Similar to a mitigation bank, an in-lieu fee program sells compensatory mitigation credits to permittees whose obligation to provide compensatory mitigation is then transferred to the in-lieu program sponsor.” (Fed. Reg. 40 CFR Part 230)

The fee has been determined using the Restoration And Permitting (RAP) Calculator for Lake Washington and will be paid to King County Water & Land Resources Division. This funding has

been used to remove 350 derelict piles from the mouth of the Cedar River in Lake Washington.

## Conclusion

Juvenile Chinook salmon, and other salmonids, rear and migrate along the Lake Washington shoreline. Lake Washington is a Shoreline of the State.

There will be temporary impacts from noise during construction but will be limited to mostly hand tools and a work boats.

The project will minimize construction effects on the environment by following the prescribed fish window and using applicable BMPs to prevent construction spills, turbidity, and floating debris from escaping the area. The construction crew will retrieve all dropped items from the bottom and dispose of them properly. The effects of construction will be short term.

The new moorage cover will use a transparent cover that will allow light to reach the water beneath and will not cause effects associated with overwater coverage.

A shoreline planting plan will be implemented that will add 1 Western red cedar, 1 shore pine, and 3 native shrubs (2 species) that will provide natural shading, allochthonous food sources and will eventually be a source of woody materials that will improve shoreline conditions at the site in the long-term. The owner has also opted to pay into the In Lieu Fee program that will be used for conservation projects that benefit salmon in King County.

This project has been designed to meet current residential dock standards and will use Best Management Practices to reduce project impacts. The conservation measures are designed to improve ecological functions or prevent further degradation of habitat **and will result in No Net Loss of ecological functions.**

## Document Preparers

Brad Thiele

Biologist

30 years of experience

Northwest Environmental  
Consulting, LLC (NVEC)

The conclusions and findings in this report are based on field observations and measurements and represent our best professional judgment and to some extent rely on other professional service firms and available site information. Within the limitations of project scope, budget, and seasonal variations, we believe the information provided herein is accurate and true to the best of our knowledge. Northwest Environmental Consulting does not warrant any assumptions or conclusions not expressly made in this report, or based on information or analyses other than what is included herein.

## REFERENCES

---

King County. 2024. King County iMap. Online database. Accessed January 2024 at <https://gismaps.kingcounty.gov/iMap/>

Washington Department of Fish and Wildlife (WDFW). 2024. Priority Habitats and Species. Online database. Accessed January 2024 at <http://apps.wdfw.wa.gov/phsontheweb/>

WDFW. 2024. SalmonScape. Online database. Accessed January 2024 at <http://apps.wdfw.wa.gov/salmonscape/>

# **Appendix A: Project Drawings**

---

# SITE PLAN

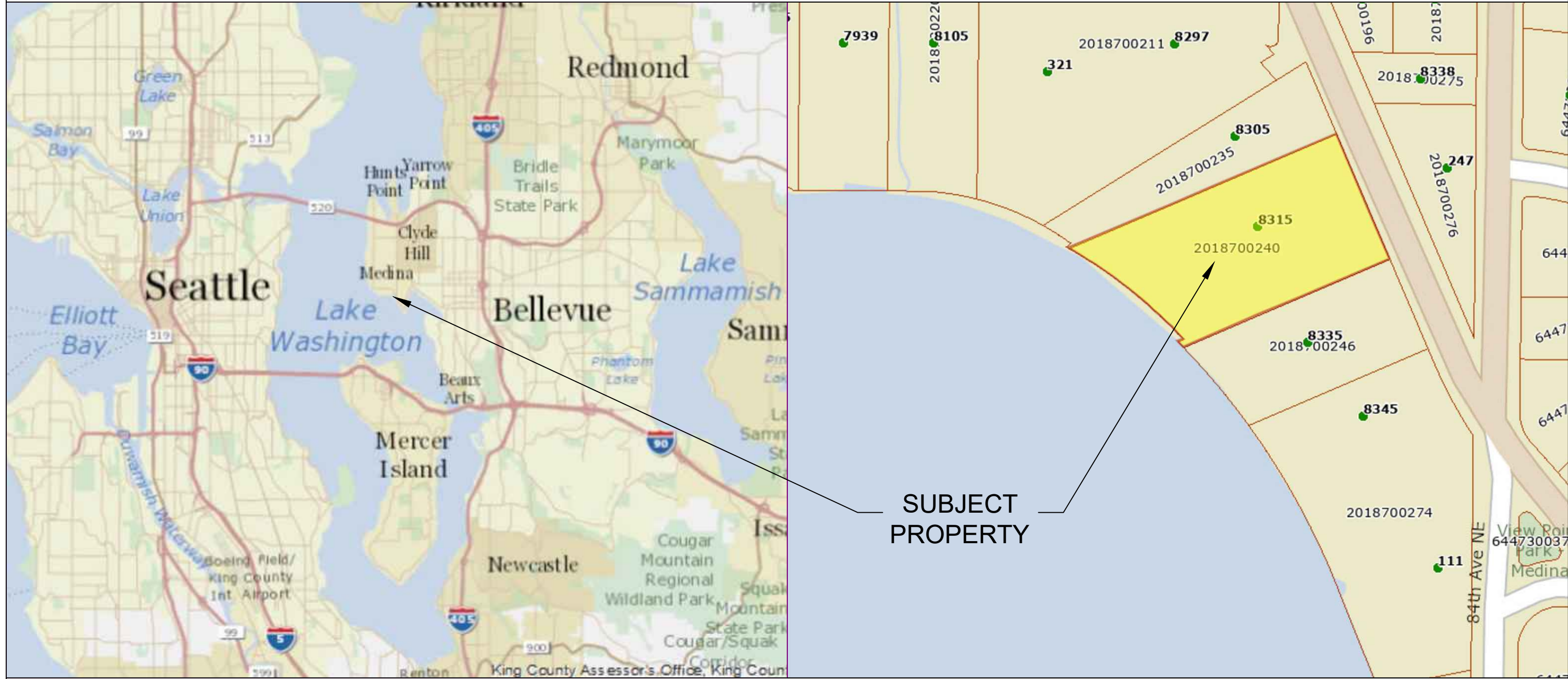

Pin: 2018700240

Legal Description: DE VRIES LK WASHINGTON TRS UNREC LOT B TGW SH LDS ADJ TGW NWLY 75 FT LOT C TGW SH LDS ADJ

Plat Block:  
Plat Lot: B-C

Parcel  
LAT: 47.61383  
LONG: -122.22941

Dock  
LAT: 47.613597  
LONG: -122.229922

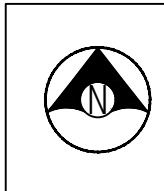

Seaborn Pile Driving  
1080 W Ewing St  
Seattle, WA 98119  
Office: 206-236-1700 ext. 5  
www.seabornpiledriving.com

Scope of Work: We propose to install a 338 sqft moorage cover.

<p>County: King County Location: Lake Washington</p>	<p>Applicant: Jain Residence 8315 Overlake Dr West Medina, WA 98039</p>	<p>Datum: CORPS OF ENGINEERS 1919 SW Quarter Of Section 24, Township 14, Range 05</p>	<p>Adjacent Owners: NICO SEBASTIAN LLC 8305 OVERLAKE DR W 98039</p>
<p>Created: 07/07/23 Last Updated: 10/9/2023 2:31 PM Kelse</p>		<p>MEDINA CONCORD LLC 8335 OVERLAKE DR W</p>	<p><b>SHEET 1.0</b></p>
<p>NWS-2023-XXX PAGE 1 OF 12</p>			



# GENERAL NOTES:

## MATERIALS SPEC LIST:

### **Boat Lifts:** Aluminum

- \* SL10014ARW - 146" x 191"

## CODE REFERENCES: Medina

**We are applying for the permit to be reviewed under the:**

16.65.40. - Covered moorage



Seaborn Pile Driving  
1080 W Ewing St  
Seattle, WA 98119

Office: 206-236-1700 ext. 5  
[www.seabornpiledriving.com](http://www.seabornpiledriving.com)

Scope of Work: We propose to install a 338 sqft moorage cover.

County: King County  
Location: Lake Washington

Applicant: Jain Residence  
8315 Overlake Dr West  
Medina, WA 98039

Datum: CORPS OF ENGINEERS 1919  
SW Quarter Of Section 24, Township 14, Range 05

Adjacent Owners:  
NICO SEBASTIAN LLC  
8305 OVERLAKE DR W 98039  
MEDINA CONCORD LLC  
8335 OVERLAKE DR W

Created: 07/07/23

Last Updated: 10/9/2023 2:31 PM Kelse

**SHEET**  
**2.0**

# EXISTING CONDITIONS

**\*\*CLEAN UP LAKE AROUND PROJECT\*\***

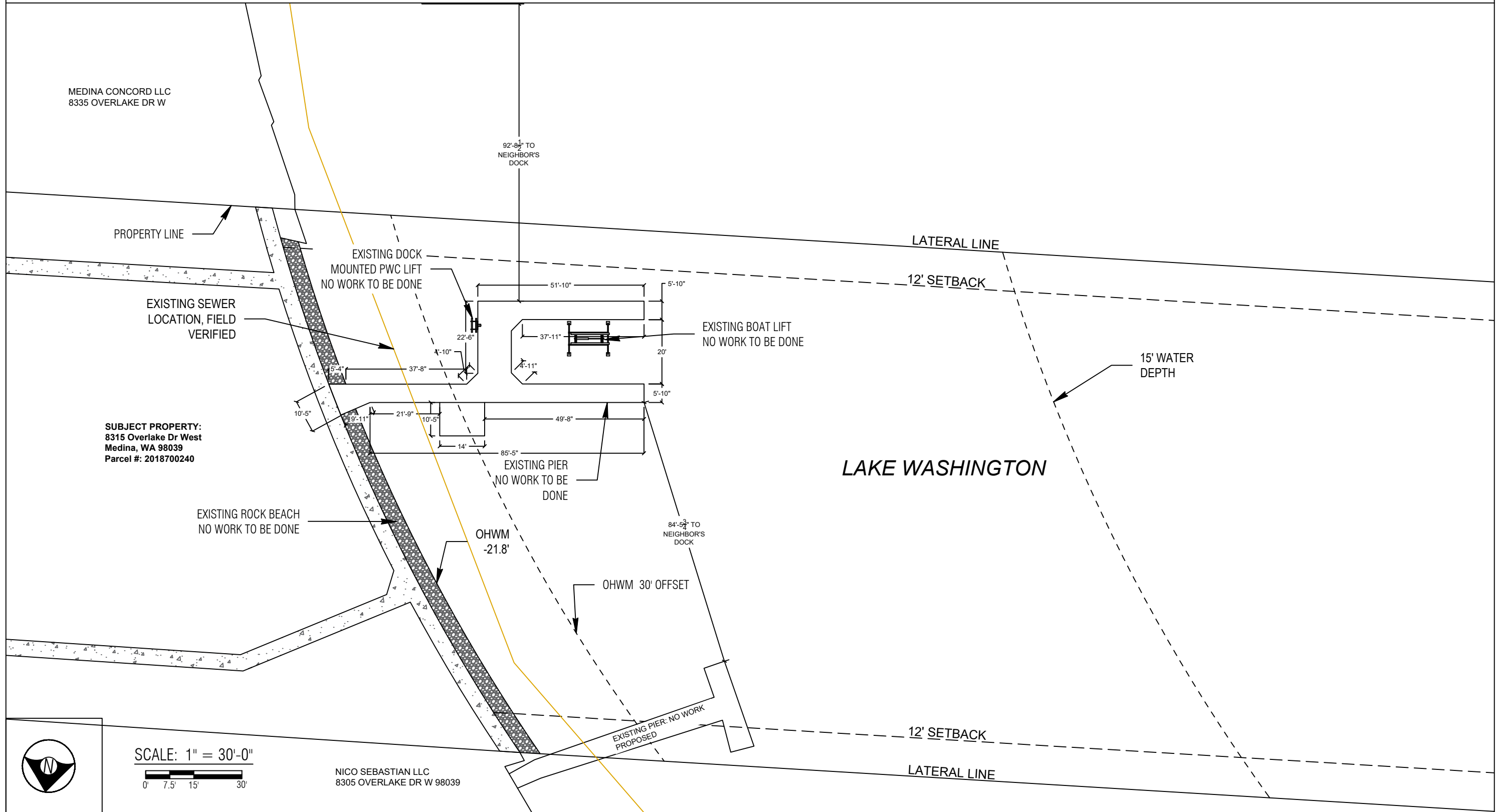

County: King County  
Location: Lake Washington

Applicant: Jain Residence  
8315 Overlake Dr West  
Medina, WA 98039

Datum: CORPS OF ENGINEERS 1919  
SW Quarter Of Section 24, Township 14, Range 05

Adjacent Owners:  
MEDINA CONCORD LLC  
8335 OVERLAKE DR W

NICO SEBASTIAN LLC  
8305 OVERLAKE DR W 98039

Last Updated: 10/9/2023 2:31 PM Kelse  
Created: 07/07/23



**Seaborn Pile Driving**  
1080 W Ewing St  
Seattle, WA 98119

Office: 206-236-1700 ext. 5  
[www.seabornpiledriving.com](http://www.seabornpiledriving.com)

**Scope of Work: We propose to install a 338 sqft moorage cover.**

**SHEET**  
**3.0**

NWS-2023-XXX  
PAGE 3 OF 12

# PROPOSED CONDITIONS

**\*\*CLEAN UP LAKE AROUND PROJECT\*\***

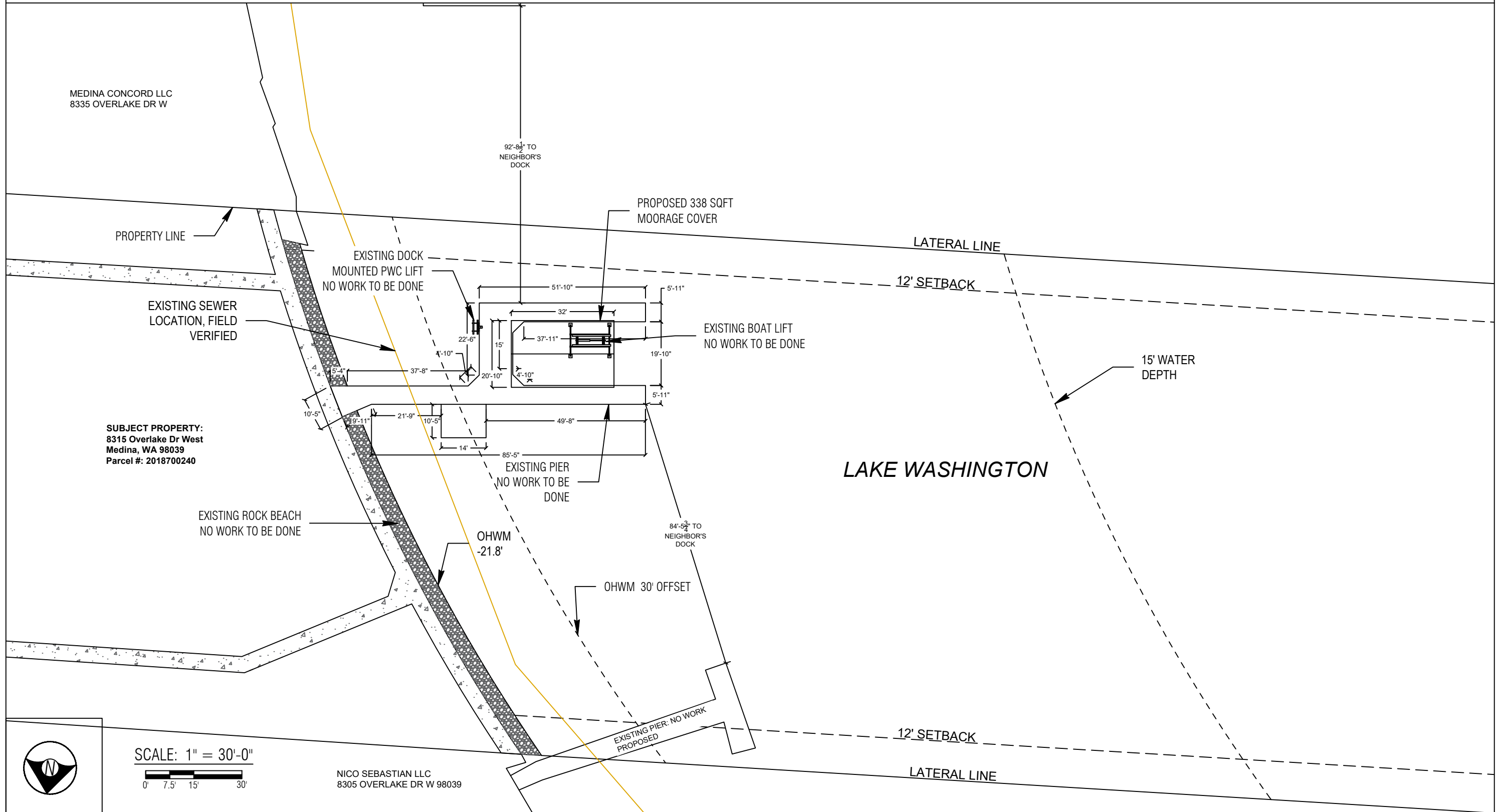

NICO SEBASTIAN LLC  
8305 OVERLAKE DR W 98039



Seaborn Pile Driving  
1080 W Ewing St  
Seattle, WA 98119  
Office: 206-236-1700 ext. 5  
www.seabornpiledriving.com

Scope of Work: We propose to install a 338 sqft moorage cover.

County: King County  
Location: Lake Washington  
Applicant: Jain Residence  
8315 Overlake Dr West  
Medina, WA 98039  
Datum: CORPS OF ENGINEERS 1919  
SW Quarter Of Section 24, Township 14, Range 05  
Adjacent Owners:  
MEDINA CONCORD LLC  
8335 OVERLAKE DR W  
NICO SEBASTIAN LLC  
8305 OVERLAKE DR W 98039  
Created: 07/07/23  
Last Updated: 10/9/2023 2:31 PM Kelse

**SHEET**  
**4.0**  
NWS-2023-XXX  
PAGE 4 OF 12



# PIER DETAILS EXISTING/PROPOSED - SECTION VIEW

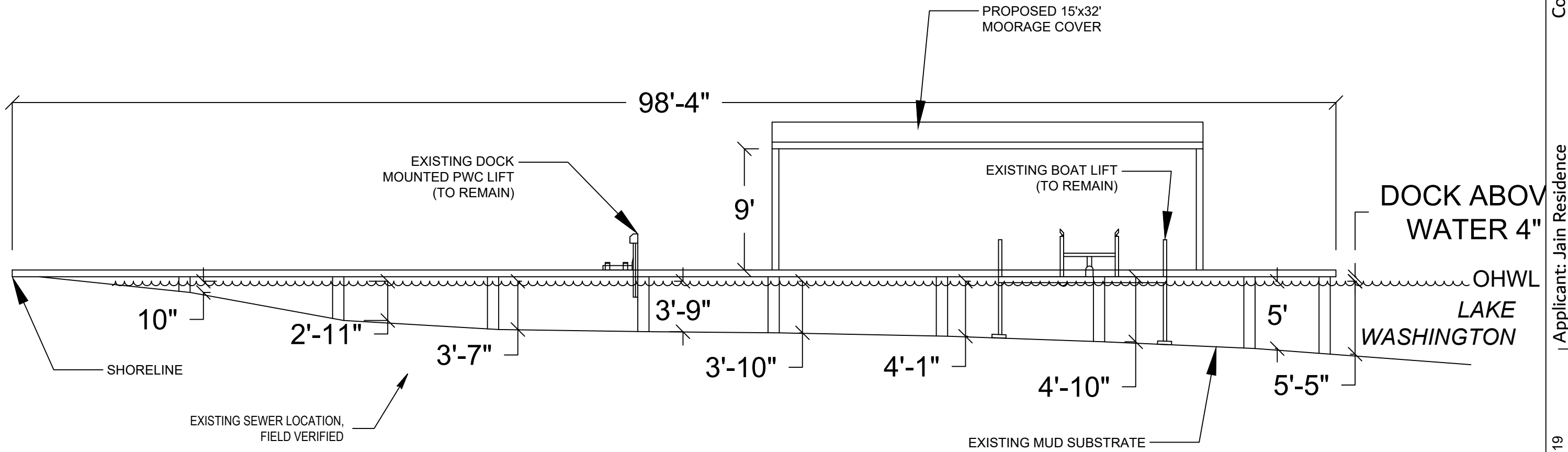

SECTION VIEW: A'-A'



Seaborn Pile Driving  
1080 W Ewing St  
Seattle, WA 98119

Office: 206-236-1700 ext. 5  
www.seabornpiledriving.com

Scope of Work: We propose to install a 338 sqft moorage cover.

County: King County  
Location: Lake Washington

Applicant: Jain Residence  
8315 Overlake Dr West  
Medina, WA 98039

Datum: CORPS OF ENGINEERS 1919  
SW Quarter Of Section 24, Township 14, Range 05

Adjacent Owners:  
NICO SEBASTIAN LLC  
8305 OVERLAKE DR W 98039

MEDINA CONCORD LLC  
8335 OVERLAKE DR W

Created: 07/07/23

Last Updated: 10/9/2023 2:31 PM Kelse

**SHEET**  
**6.0**

# BMP INFORMATION

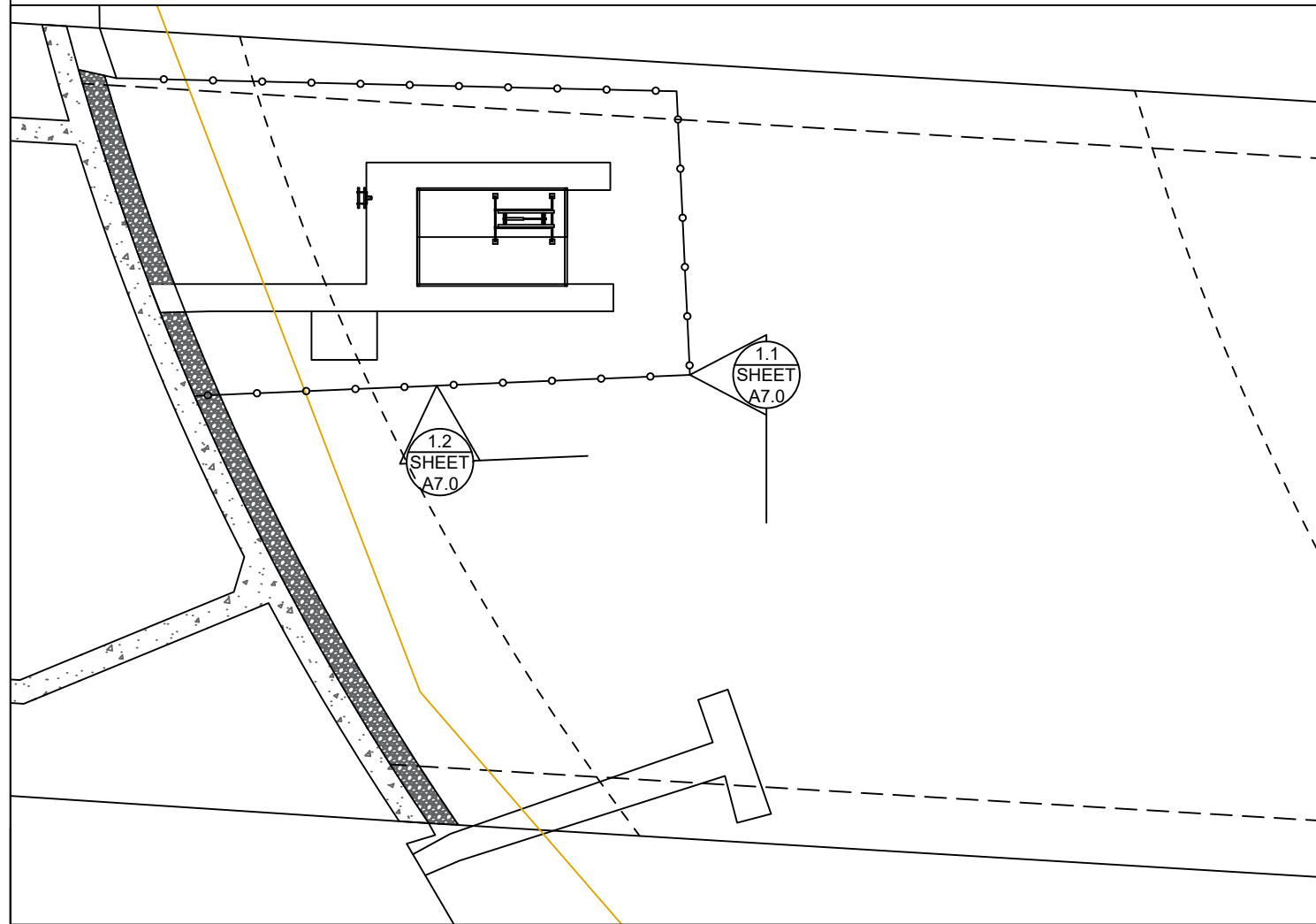

## BMP NOTES:

- A. Constant vigilance shall be kept for the presence of protected fish species during all aspects of the proposed action, particularly during in-water activities such as vessel movement, deployment of anchors & spuds, pile driving, dredging, and placement of gravels and other fill.
1. The project manager shall designate an appropriate number of competent observers to survey the project site and adjacent areas for protected species, including the presence of fish as conditions allow.
  2. Visual surveys shall be made prior to the start of work each day, and prior to resumption of work following any break of more than an hour. Periodic additional visual surveys throughout the work day are strongly recommended.
  3. All in-water work shall be done during the in-water work window for the waterbody. Where there is a difference between the USCOE and WDFW work windows, the overlap of the two shall apply.
  4. All pile driving and extraction shall be postponed or halted when obvious aggregations or schooling of fish are observed within 50 yards of that work, and shall only begin/resume after the animals have voluntarily departed the area.
  5. When piloting vessels, vessel operators shall operate at speeds and power settings to avoid grounding vessels, and minimize substrate scour and mobilization of bottom sediments.
- B. No contamination of the marine environment shall result from project-related activities.
1. Appropriate materials to contain and clean potential spills shall be stored and readily available at the work site and/or aboard project-related vessels.
  2. The project manager and heavy equipment operators shall perform daily pre-work equipment inspections for cleanliness and leaks. All heavy equipment operations shall be postponed or halted should a leak be detected, and shall not proceed until the leak is repaired and the equipment is cleaned.
  3. To the greatest extent practicable, utilize biodegradable oils for equipment that would be operated in or near water.
  4. Fueling of land-based vehicles and equipment shall take place at least 50 feet away from the water, preferably over an impervious surface. Fueling of vessels shall be done at approved fueling facilities.
  5. Turbidity and siltation from project-related work shall be minimized and contained through the appropriate use of erosion control practices, effective silt containment devices, and the curtailment of work during adverse weather and tidal/flow conditions.
  6. All wastes shall be collected and contained for proper disposal at approved upland disposal sites appropriate for the material(s).
  7. When removing piles and other similarly treated wood, containment curtain must fully enclose the work area. Wood debris, oils, and any other materials released into lake waters must be collected, removed, and properly disposed of at approved disposal sites.
  8. All in- and over-water wood cutting would be limited to the minimum required to remove the subject wood component, and all cutting work should be enclosed within floating containment curtain.
  9. When removing piles, no actions shall be taken that would cause adhering sediments to return to lake waters.
  10. Above-water containment shall be installed around removed piles to prevent sediment laden waters from returning to lake waters.
  11. Construction staging (including stocking of materials, etc.) will occur on the supply barge.
  12. All Exposed wood to be used on the project will be treated with a cheminite treatment.

DETAIL 1.1

DETAIL 1.2

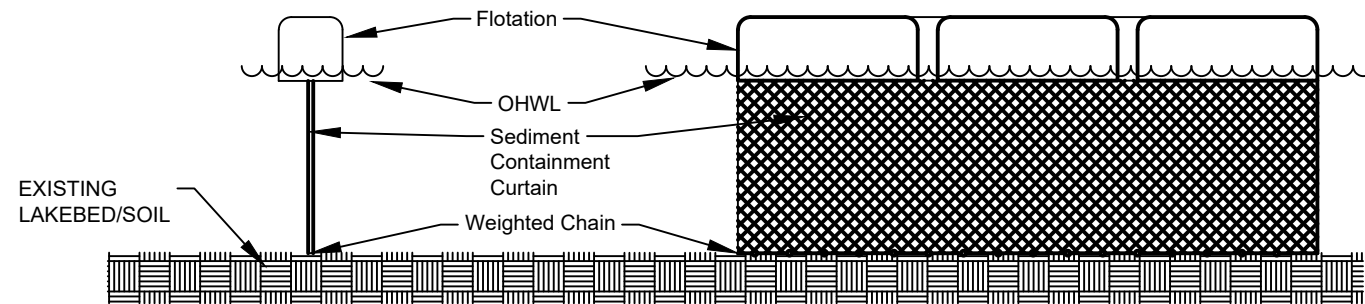

DETAIL 1.1 & 1.2



Seaborn Pile Driving  
1080 W Ewing St  
Seattle, WA 98119

Office: 206-236-1700 ext. 5  
www.seabornpiledriving.com

Scope of Work: We propose to install a 338 sqft moorage cover.

County: King County  
Location: Lake Washington

Applicant: Jain Residence  
8315 Overlake Dr West  
Medina, WA 98039

Datum: CORPS OF ENGINEERS 1919  
SW Quarter Of Section 24, Township 14, Range 05

Adjacent Owners:  
NICO SEBASTIAN LLC  
8305 OVERLAKE DR W 98039

MEDINA CONCORD LLC  
8335 OVERLAKE DR W

Created: 07/07/23

Last Updated: 10/9/2023 2:31 PM Kelse

**SHEET**  
**7.0**



# MITIGATION PLAN

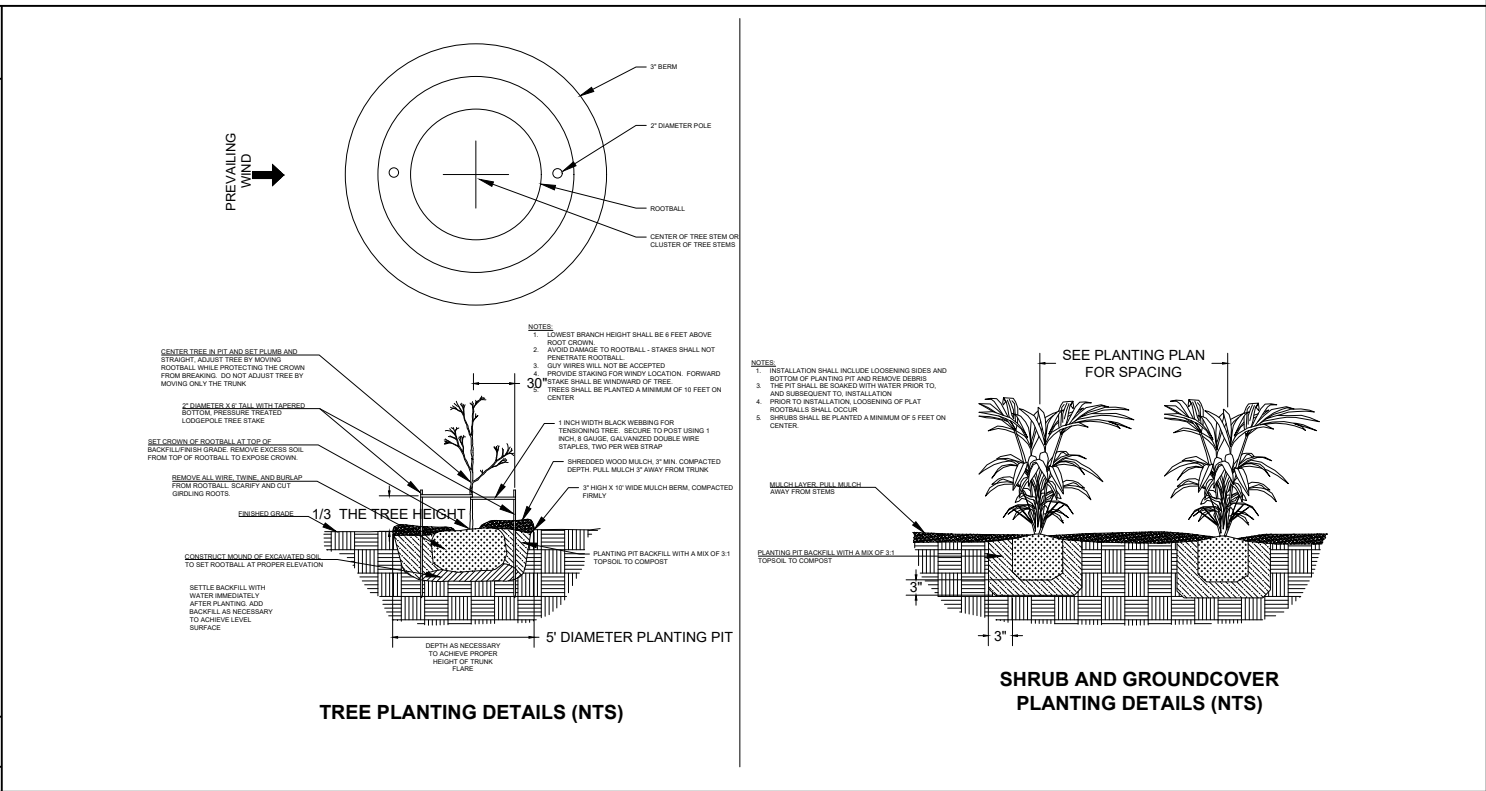
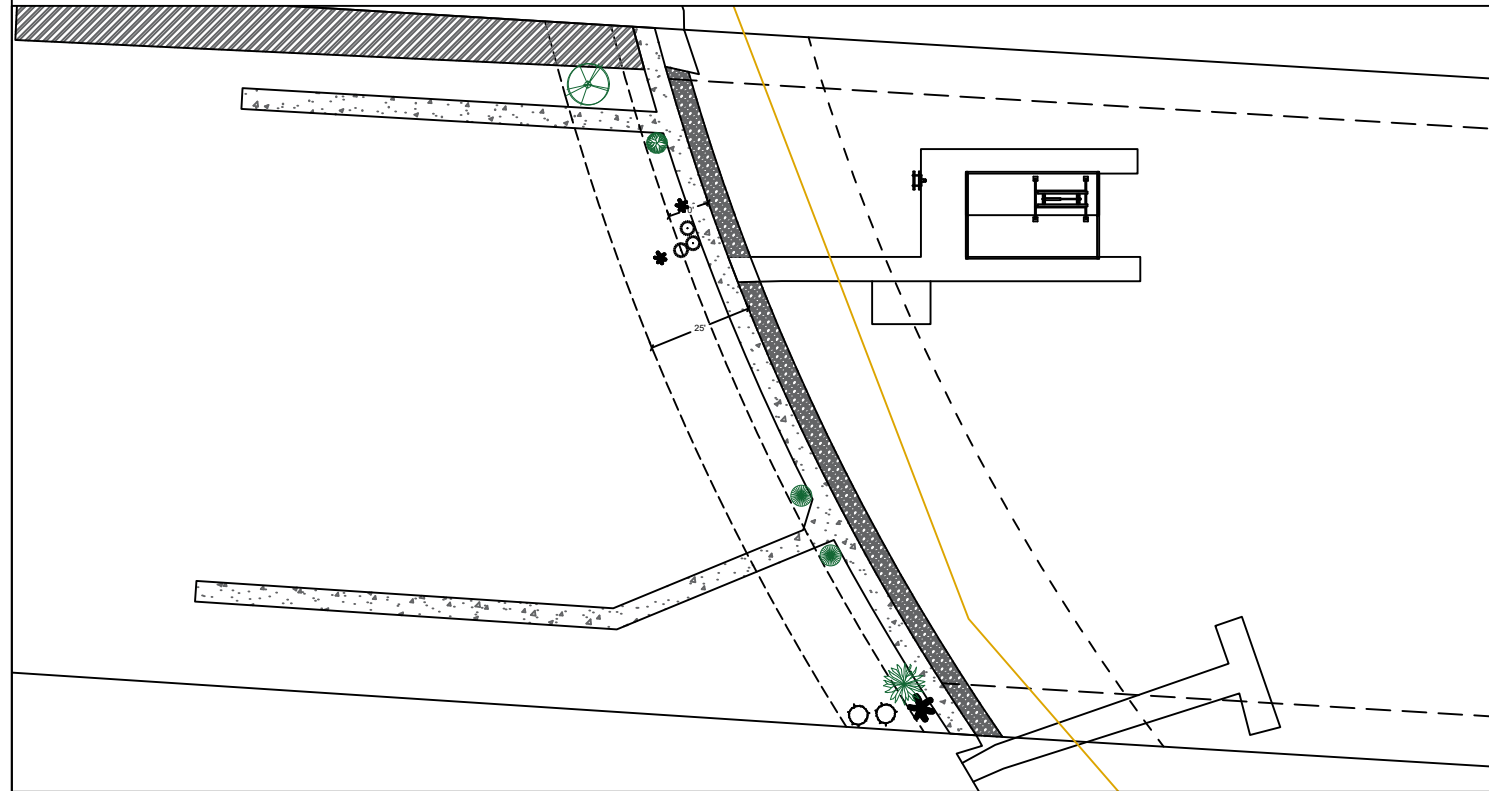

**Notes:**

1. Shrubs are shown, and shall be planted, at least five feet on center. Trees are shown, and shall be planted, at least ten feet to center.
2. The property owner will implement and abide by the shoreline planting plan. The plants shall be installed before or concurrent with the work authorized by this permit. A report, as-built drawing and photographs demonstrating the plants have been installed or a report on the status of project construction will be submitted to the U.S. Army Corps of Engineers, Seattle District, Regulatory Branch, within 12 months from the date of permit issuance. This reporting requirement may be met by completing and submitting a U.S. Army Corps of Engineers approved Report for Mitigation Work Completion form.
3. The property owner will maintain and monitor the survival of installed shoreline plantings for five years after the U.S. Army Corps of Engineers accepts the as-built report. Installed plants shall achieve 100% survival during monitoring Years 1 and 2. Installed plants shall achieve at least 80% survival during monitoring Years 3, 4 and 5. Percent survival is based on the total number of plants installed in accordance with the approved riparian planting plan. Individual plants that die will be replaced with native riparian species in order to meet the survival performance standards.
4. The property owner will provide annual monitoring reports for five years (Monitoring Years 1-5). Each annual monitoring report will include written and photographic documentation on plant mortality and replanting efforts and will document whether the performance standards are being met. Photos will be taken from established points and used repeatedly for each monitoring year. In addition to photos at designated points, photo documentation will include a panoramic view of the entire planting area. Submitted photos will be formatted on standard 8 1/2 x 11" paper, dated with the date the photo was taken, and clearly labeled with the direction from which the photo was taken. The photo location points will be identified on an appropriate drawing. Annual shoreline planting monitoring reports will be submitted to the U.S. Army Corps of Engineers, Seattle District, Regulatory Branch, by November 31 of each monitoring year. This reporting requirement may be met by completing and submitting a U.S. Army Corps of Engineers approved Mitigation Planting Monitoring Report form.

## PROPOSED PLANTING SPECIES/QUANTITIES

SYMBOL	LATIN NAME	COMMON NAME	QTY	SIZE
	<i>Thuja plicata</i>	Western Red Cedar	1	3 ft
	<i>Pinus contorta v contorta</i>	Shore pine	1	3 ft
	<i>Rosa nutkana</i>	Nootka Rose	1	1 Gallon
	<i>Philadelphus lewisii</i>	Mock Orange	2	1 Gallon

**PLANTS:** Shrubs to be installed 5ft on center and trees to be installed 10ft on center.



Seaborn Pile Driving  
1080 W Ewing St  
Seattle, WA 98119  
Office: 206-236-1700 ext. 5  
www.seabornpiledriving.com



Scope of Work: We propose to install a 338 sqft moorage cover.

County: King County  
Location: Lake Washington  
Applicant: Jain Residence  
8315 Overlake Dr West  
Medina, WA 98039  
Datum: CORPS OF ENGINEERS 1919  
SW Quarter Of Section 24, Township 14, Range 05  
Adjacent Owners:  
NICO SEBASTIAN LLC  
8305 OVERLAKE DR W 98039  
MEDINA CONCORD LLC  
8335 OVERLAKE DR W  
Created: 07/07/23  
Last Updated: 10/9/2023 2:31 PM Kelse  
SHEET 8.0  
NWS-2023-XXX  
PAGE 8 OF 12

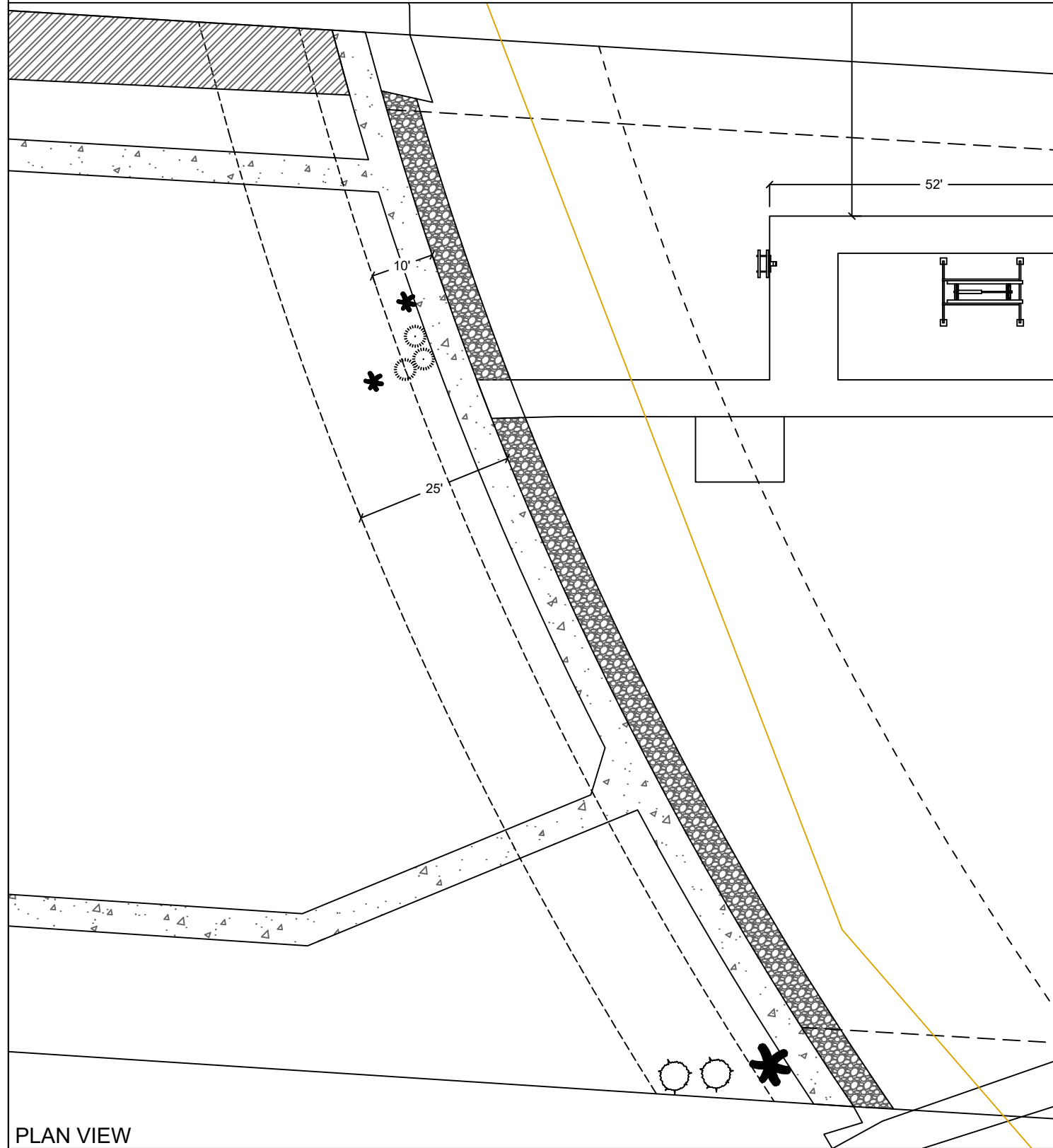
# EXISTING PLANT PLAN

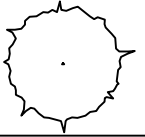
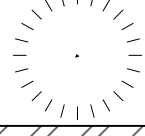
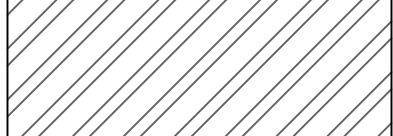

## EXISTING PLANTING SPECIES/QUANTITIES

SYMBOL	SCIENTIFIC NAME	COMMON NAME	QTY	SIZE
	<i>Chamaecyparis obtusa</i>	Hinoki cypress	2	5' x 12'
	<i>Sporobolus heterolepis</i>	Prairie Dropseed	3	3'
	<i>Juniper communis</i>	Juniper	many	varies
	<i>Berberis thunbergii</i>	Japanese Barberry	3	varies

PLAN VIEW

EXISTING PLANTS TABLE

Scope of Work: We propose to install a 338 sqft moorage cover.



Seaborn Pile Driving  
 1080 W Ewing St  
 Seattle, WA 98119  
 Office: 206-236-1700 ext. 5  
[www.seabornpiledriving.com](http://www.seabornpiledriving.com)

County: King County  
 Location: Lake Washington  
 Applicant: Jain Residence  
 8315 Overlake Dr West  
 Medina, WA 98039  
 Datum: CORPS OF ENGINEERS 1919  
 SW Quarter Of Section 24, Township 14, Range 05  
 Adjacent Owners:  
 NICO SEBASTIAN LLC  
 8305 OVERLAKE DR W 98039  
 MEDINA CONCORD LLC  
 8335 OVERLAKE DR W

**SHEET**  
**9.0**



# GENERAL ENGINEERING NOTES:



Seaborn Pile Driving  
1080 W Ewing St  
Seattle, WA 98119

Office: 206-236-1700 ext. 5  
[www.seabornpiledriving.com](http://www.seabornpiledriving.com)

Scope of Work: We propose to install a 338 sqft moorage cover.

**SHEET**  
**10.0**

Datum: CORPS OF ENGINEERS 1919  
SW Quarter Of Section 24, Township 14, Range 05  
Adjacent Owners:  
NICO SEBASTIAN LLC  
8305 OVERLAKE DR W 98039  
MEDINA CONCORD LLC  
8335 OVERLAKE DR W

Applicant: Jain Residence  
8315 Overlake Dr West  
Medina, WA 98039

County: King County  
Location: Lake Washington

Created: 07/07/23

Last Updated: 10/9/2023 4:39 PM Kelse

# FRAMING PLAN

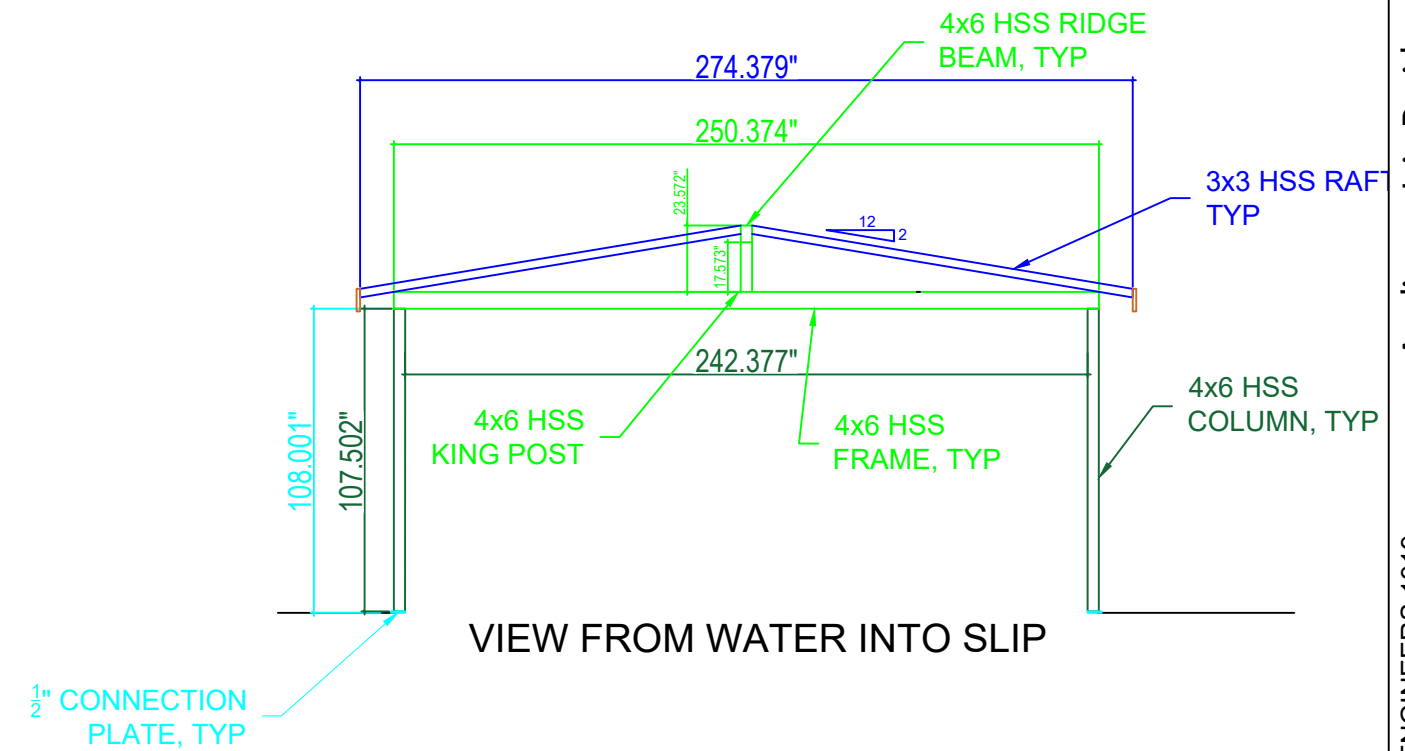
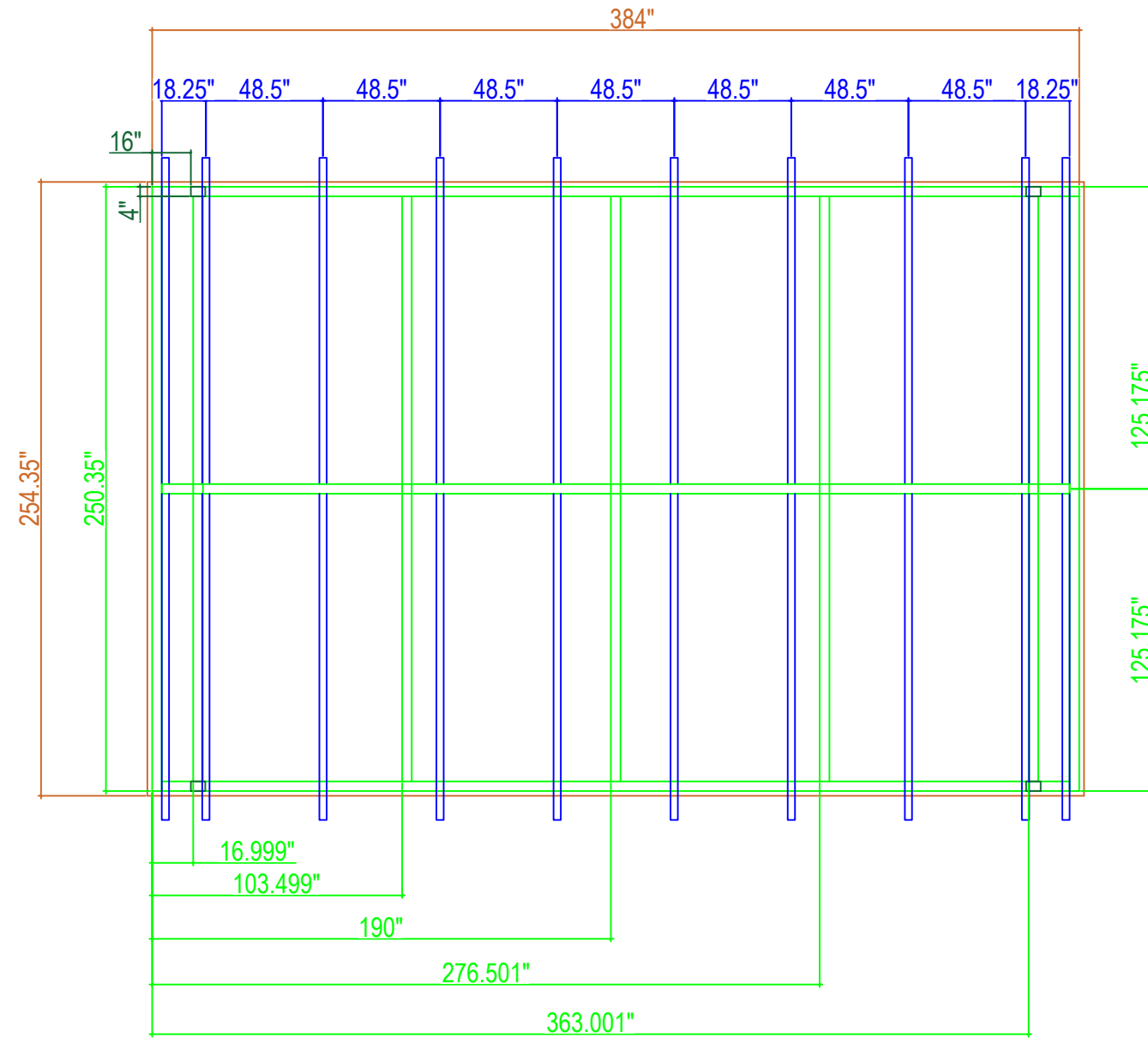

VIEW FROM WATER INTO SLIP



Seaborn Pile Driving  
1080 W Ewing St  
Seattle, WA 98119

Office: 206-236-1700 ext. 5  
www.seabornpiledriving.com

Scope of Work: We propose to install a 338 sqft moorage cover.

County: King County  
Location: Lake Washington

Applicant: Jain Residence  
8315 Overlake Dr West  
Medina, WA 98039

Datum: CORPS OF ENGINEERS 1919  
SW Quarter Of Section 24, Township 14, Range 05

Adjacent Owners:  
NICO SEBASTIAN LLC  
8305 OVERLAKE DR W 98039

MEDINA CONCORD LLC  
8335 OVERLAKE DR W

Last Updated: 10/9/2023 4:39 PM Kelse

Created: 07/07/23

**SHEET**  
**11.0**

# DETAILS - REPAIR

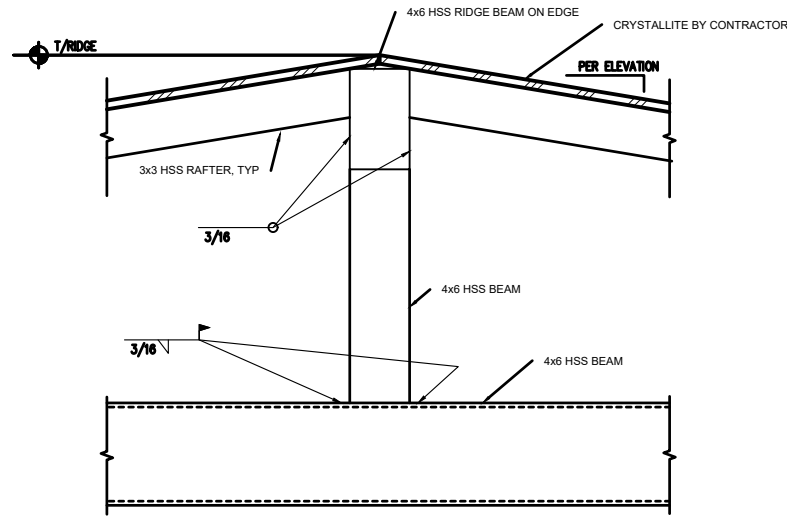

**S1** RIDGE BEAM FRAMING AT SUPPORT  
SCALE: 1" = 1"

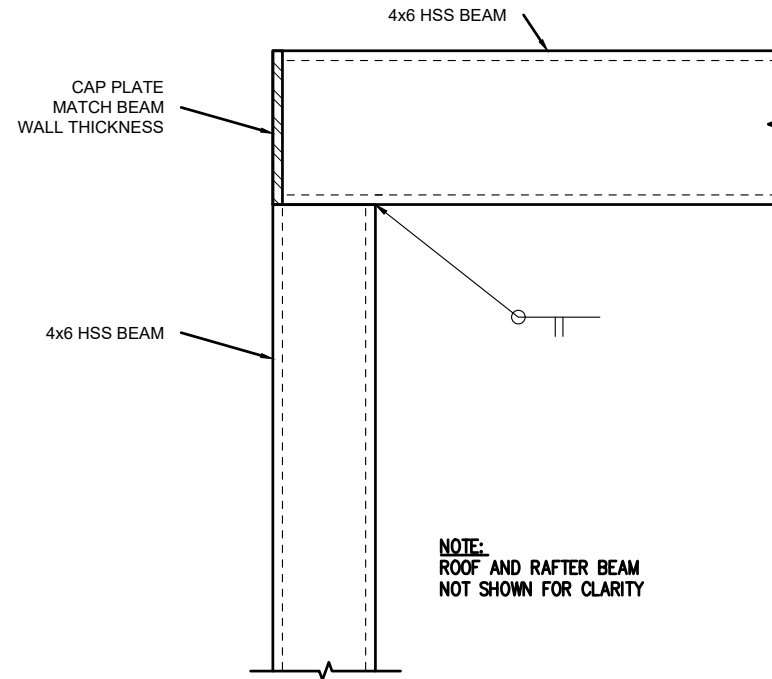

**S2** HSS BEAM-TO-COLUMN CONNECTION  
SCALE: 1-1/2" = 1"

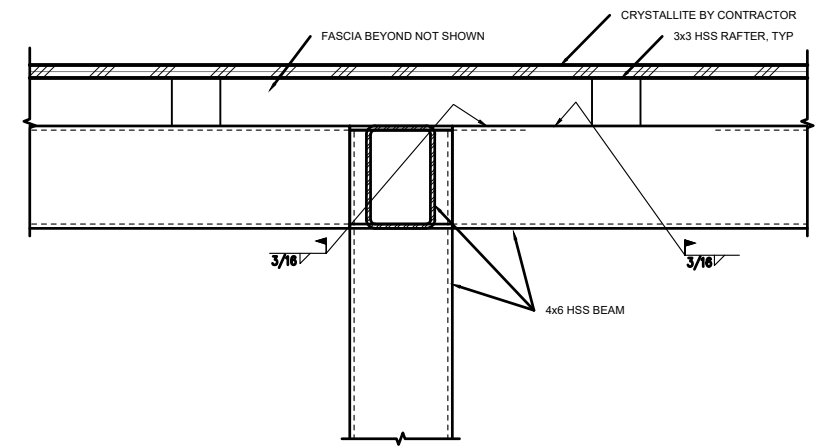

**S3** RAFTERS TO BEAM-TO-COLUMN  
SCALE: 1" = 1"

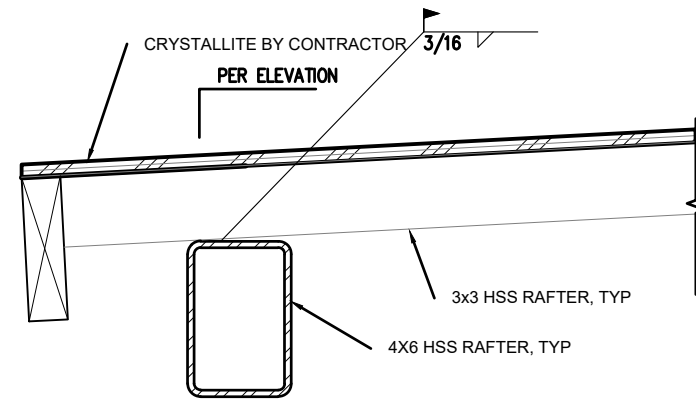

**S4** RAFTER-TO-BEAM CONNECTION  
SCALE: 1-1/2" = 1"

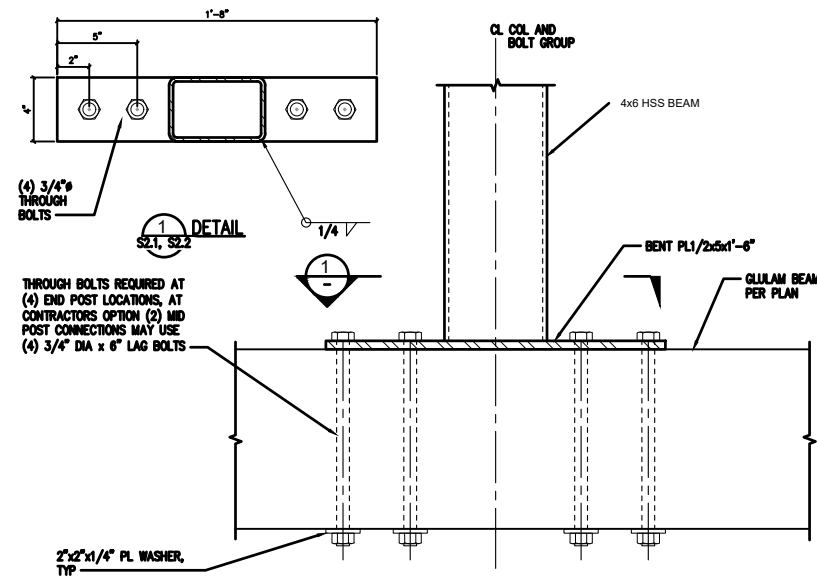

**S5** HSS TO EXISTING DOCK GLB  
SCALE: 1" = 1"

**S6** TYPICAL ROOF RAFTER AT BEAM  
SCALE: 1" = 1"



Seaborn Pile Driving  
1080 W Ewing St  
Seattle, WA 98119

Office: 206-236-1700 ext. 5  
www.seabornpiledriving.com

Scope of Work: We propose to install a 338 sqft moorage cover.

County: King County  
Location: Lake Washington

Applicant: Jain Residence  
8315 Overlake Dr West  
Medina, WA 98039

Datum: CORPS OF ENGINEERS 1919  
SW Quarter Of Section 24, Township 14, Range 05

Adjacent Owners:  
NICO SEBASTIAN LLC  
8305 OVERLAKE DR W 98039

MEDINA CONCORD LLC  
8335 OVERLAKE DR W

Last Updated: 10/9/2023 4:39 PM Kelse

Created: 07/07/23

**SHEET**  
**12.0**

NWS-2023-XXX  
PAGE 12 OF 12

## **Appendix B: Site Photographs**

---



Photo 1 - Existing dock looking waterward.



Photo 2 - Existing dock looking landward.





Photo 3 - Existing shoreline conditions looking north.



Photo 4 - Existing shoreline conditions looking south.





Photo 5 - Existing conditions north of site.



Photo 6 - Existing shoreline conditions looking south.