



Mike Twitty, MAI, CFA
Pinellas County Property Appraiser

Parcel Summary
(as of 27-Jun-2024)

Parcel Number

10-31-15-34380-015-0050

- Owner Name
TUCKER, BLAZIA P
- Property Use
0110 Single Family Home
- Site Address
**435 S BAYSHORE DR
MADEIRA BEACH, FL 33708**
- Mailing Address
**435 S BAYSHORE DR
MADEIRA BEACH, FL 33708-2305**
- Legal Description
GULF SHORES 4TH ADD BLK O, LOT 5 LESS W 1.25FT
- Current Tax District
MADEIRA BEACH (MB)
- Year Built
1950

Living SF	Gross SF	Living Units	Buildings
1,759	2,197	1	1

Parcel Map

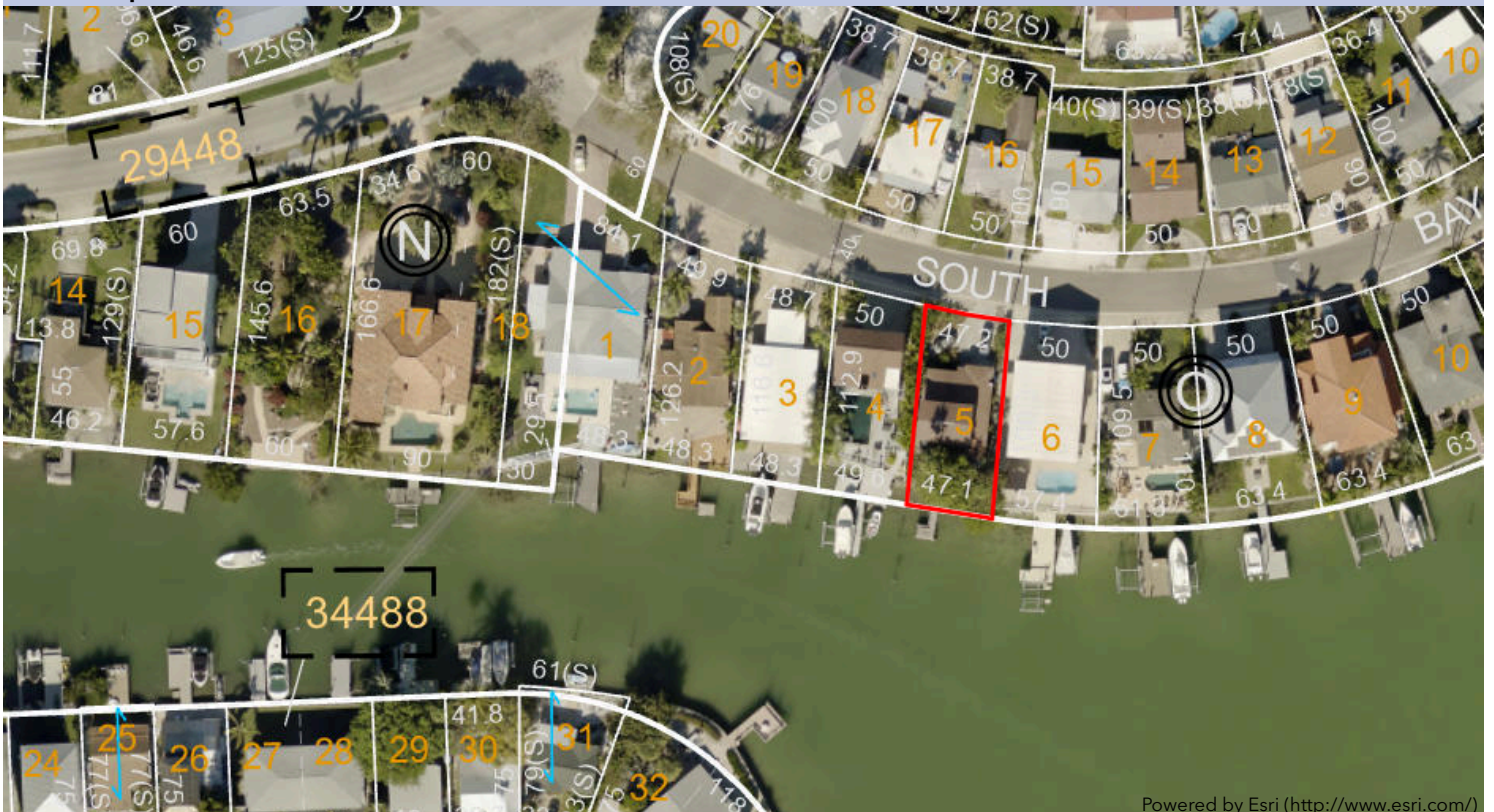

Powered by Esri (<http://www.esri.com/>)

Exemptions				Property Exemptions & Classifications			
Year	Homestead	Use %	Status				
2025	Yes	100%	Assuming no ownership changes before Jan. 1, 2025.	No Property Exemptions or Classifications found. Please note that Ownership Exemptions (Homestead, Senior, Widow/Widower, Veterans, First Responder, etc... will not display here).			
2024	Yes	100%					
2023	Yes	100%					

Miscellaneous Parcel Info

Last Recorded Deed	Sales Comparison	Census Tract	Evacuation Zone	Flood Zone	Elevation Certificate	Zoning	Plat Bk/Pg
10630/1569	\$799,100	278.02	A	Current FEMA Maps	Check for EC	Zoning Map	23/61

2023 Final Values

Year	Just/Market Value	Assessed Value/SOH Cap	County Taxable Value	School Taxable Value	Municipal Taxable Value
2023	\$692,358	\$231,336	\$176,336	\$201,336	\$176,336

Value History

Year	Homestead Exemption	Just/Market Value	Assessed Value/SOH Cap	County Taxable Value	School Taxable Value	Municipal Taxable Value
2022	Y	\$542,015	\$224,598	\$174,098	\$199,098	\$174,098
2021	Y	\$424,982	\$218,056	\$167,556	\$192,556	\$167,556
2020	Y	\$374,219	\$215,045	\$164,545	\$189,545	\$164,545
2019	Y	\$362,162	\$210,210	\$159,710	\$184,710	\$159,710
2018	Y	\$353,702	\$206,290	\$155,790	\$180,790	\$155,790

2023 Tax Information

 Do not rely on current taxes as an estimate following a change in ownership. A significant change in taxable value may occur after a transfer due to a loss of exemptions, reset of the Save Our Homes or 10% Cap, and/or market conditions. Please use our [Tax Estimator](#) to estimate taxes under new ownership.

Tax Bill	2023 Millage Rate	Tax District
View 2023 Tax Bill	16.1412	(MB)

Sales History

Sale Date	Price	Qualified / Unqualified	Vacant / Improved	Grantor	Grantee	Book / Page
18-Aug-1999	\$155,000	Q	I	O CONNOR JOHN J	TUCKER, BLAZIA P	10630/1569
01-Aug-1994	\$140,000	Q	I	GENTZEL J ERIC	O'CONNOR, JOHN J.	08742/0227
23-Feb-1987	\$95,000	Q				06432/1089

2023 Land Information

Land Area: 5,101 sf | 0.11 acres Frontage and/or View: Intracoastal Seawall: Yes

Property Use	Land Dimensions	Unit Value	Units	Method	Total Adjustments	Adjusted Value
Single Family	46x110	\$15,000	46.50	FF	1.1544	\$805,194

2023 Building 1 Structural Elements and Sub Area Information

Structural Elements		Sub Area	Living Area SF	Gross Area SF
Foundation:	Continuous Footing Poured			
Floor System:	Slab On Grade	Base (BAS):	1,265	1,265
Exterior Walls:	Cb Stucco/Cb Reclad	Upper Story (USF):	494	494
Unit Stories:	2	Garage (GRF):	0	288
Living Units:	1	Open Porch (OPF):	0	24
Roof Frame:	Gable Or Hip	Open Porch Unfinished (OPU):	0	126
Roof Cover:	Shingle Composition	Total Area SF:	1,759	2,197
Year Built:	1950			

Building Type: Single Family
 Quality: Average
 Floor Finish: Carpet/Hardtile/Hardwood
 Interior Finish: Drywall/Plaster
 Heating: Central Duct
 Cooling: Cooling (Central)
 Fixtures: 8
 Effective Age: 46

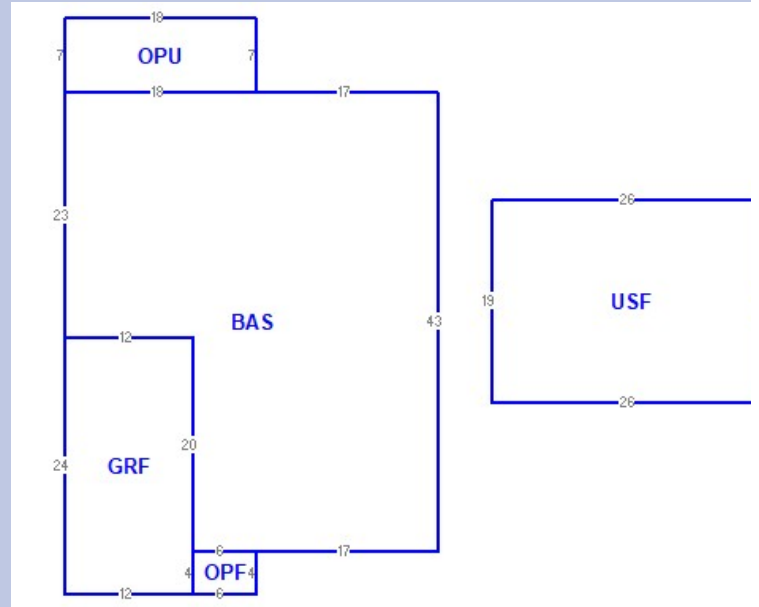

2023 Extra Features

Description	Value/Unit	Units	Total Value as New	Depreciated Value	Year
BT LFT/DAV	0.00	1	\$0	\$0	1960
DOCK	\$48.00	168.0	\$8,064	\$3,226	1960
PATIO/DECK	\$24.00	208.0	\$4,992	\$1,997	1980
PATIO/DECK	\$14.00	112.0	\$1,568	\$627	1960

Permit Data

Permit information is received from the County and Cities. This data may be incomplete and may exclude permits that do not result in field reviews (for example for water heater replacement permits). We are required to list all improvements, which may include unpermitted construction. Any questions regarding permits, or the status of non-permitted improvements, should be directed to the permitting jurisdiction in which the structure is located.

Permit Number	Description	Issue Date	Estimated Value
PER-H-CB269558	ROOF	02/19/2003	\$4,795



**CODE ENFORCEMENT
CITY OF MADEIRA BEACH**

June 27, 2024

TUCKER, BLAZIA P
435 S BAYSHORE DR
MADEIRA BEACH, FL 33708
Case Number: CE-24-63

RE Property: 435 S BAYSHORE **Parcel #**10-31-15-34380-015-0050

Legal Description: GULF SHORES 4TH ADD BLK 0, LOT 5 LESS W 1.25FT

NOTICE OF CODE VIOLATION

To whom it may concern:

During a recent review of properties, it was noted that your property is in violation of the following code/ordinance(s):

Ordinance(s):

Sec. 14-69. - Same—Maintenance of the exterior of premises.

The exterior of premises and all structures thereon including but not limited to private property and vacant lots shall be kept free of all hazards to the health, safety and welfare of persons on or near the premises. It shall be the duty of the owner/occupant of such property to promptly abate or remove the same.

(1)Garbage, trash, refuse, debris, accumulations of filth, broken glass, junk, scrap metal, scrap lumber, wastepaper products, discarded building materials, inoperative machinery, machinery parts, and similar materials shall not be stored or maintained on private property.

(3)Overhanging or overhead objects which are loose, insecurely fastened or otherwise constitute a danger of falling on persons or property by reason of their location above the ground shall not be stored or maintained on private property.

Therefore, if the action(s) specified in this notice is not completed by 8:00 am of the re-inspection date listed, the City will take legal action concerning this violation(s). This action may include the issuance of a citation and imposition of a fine of up to two hundred fifty dollars (\$250) per day.



Sec. 14-70. - Same—General maintenance.

The exterior of every structure or accessory structure (including fences, signs, screens and store fronts) shall be maintained in good repair, termite free and all surfaces thereof shall be kept painted or have similar protective coating where necessary for purpose of preservation and appearance. All surfaces shall be maintained free of broken glass, loose shingles, crumbling stone or brick, excessive peeling paint or other condition reflective of deterioration or inadequate maintenance to the end which the property itself may be preserved, safety and fire hazards eliminated, and adjoining properties will be protected from conditions which tend to decrease the property values of surrounding properties.

Sec. 110-446. - Applicability of division.

This division applies to all fences, hedges, and walls that are not specifically exempted from this division. This division does not apply to seawalls (see chapter 14, article V of this Code for regulations on seawalls).

(7)Maintenance. After construction, fences and walls must be maintained with original components and remain substantially vertical to serve their function and aesthetic purposes. Structural integrity must be maintained to prevent a danger of destruction or flight during high winds. Hedges must be maintained at or below the maximum height permitted.

Violation Detail(s):

Building on property requiring maintenance, exterior of property requiring maintenance.
Fence on property requiring maintenance.

Corrective Action(s):

Either the property owner and/or licensed contractor will need to apply for and obtain a building permit, if required to make repairs/ modifications, to comply. If a permit cannot be obtained, the structure/changes must be removed.

Please reply with a plan of corrections before the follow-up date listed:

Follow up date:
July 11, 2024

Therefore, if the action(s) specified in this notice is not completed by 8:00 am of the re-inspection date listed, the City will take legal action concerning this violation(s). This action may include the issuance of a citation and imposition of a fine of up to two hundred fifty dollars (\$250) per day.



Grace Mills, Code Compliance Officer II
City of Madeira Beach
gmills@madeirabeachfl.gov
727-742-1645

We are now using My Government Online (MGO). Please scan the QR code below, or go to www.mgoconnect.org/cp/portal to apply online for a permit, pay fees, and schedule inspections. We are no longer accepting paper, in-person permit applications.



Therefore, if the action(s) specified in this notice is not completed by 8:00 am of the re-inspection date listed, the City will take legal action concerning this violation(s). This action may include the issuance of a citation and imposition of a fine of up to two hundred fifty dollars (\$250) per day.



6/27/2024

Therefore, if the action(s) specified in this notice is not completed by 8:00 am of the re-inspection date listed, the City will take legal action concerning this violation(s). This action may include the issuance of a citation and imposition of a fine of up to two hundred fifty dollars (\$250) per day.



6/27/2024

Therefore, if the action(s) specified in this notice is not completed by 8:00 am of the re-inspection date listed, the City will take legal action concerning this violation(s). This action may include the issuance of a citation and imposition of a fine of up to two hundred fifty dollars (\$250) per day.



6/27/2024

Therefore, if the action(s) specified in this notice is not completed by 8:00 am of the re-inspection date listed, the City will take legal action concerning this violation(s). This action may include the issuance of a citation and imposition of a fine of up to two hundred fifty dollars (\$250) per day.



6/27/2024

Therefore, if the action(s) specified in this notice is not completed by 8:00 am of the re-inspection date listed, the City will take legal action concerning this violation(s). This action may include the issuance of a citation and imposition of a fine of up to two hundred fifty dollars (\$250) per day.



6/27/2024

Therefore, if the action(s) specified in this notice is not completed by 8:00 am of the re-inspection date listed, the City will take legal action concerning this violation(s). This action may include the issuance of a citation and imposition of a fine of up to two hundred fifty dollars (\$250) per day.



6/27/2024

Therefore, if the action(s) specified in this notice is not completed by 8:00 am of the re-inspection date listed, the City will take legal action concerning this violation(s). This action may include the issuance of a citation and imposition of a fine of up to two hundred fifty dollars (\$250) per day.



**CODE ENFORCEMENT
CITY OF MADEIRA BEACH**

July 16, 2024

TUCKER, BLAZIA P
435 S BAYSHORE DR
MADEIRA BEACH, FL 33708
Case Number: CE-24-63

RE Property: 435 S BAYSHORE **Parcel #**10-31-15-34380-015-0050

Legal Description: GULF SHORES 4TH ADD BLK 0, LOT 5 LESS W 1.25FT

NOTICE OF CODE VIOLATION

To whom it may concern:

During a recent review of properties, it was noted that your property is in violation of the following code/ordinance(s):

Ordinance(s):

Sec. 14-69. - Same—Maintenance of the exterior of premises.

The exterior of premises and all structures thereon including but not limited to private property and vacant lots shall be kept free of all hazards to the health, safety and welfare of persons on or near the premises. It shall be the duty of the owner/occupant of such property to promptly abate or remove the same.

(1)Garbage, trash, refuse, debris, accumulations of filth, broken glass, junk, scrap metal, scrap lumber, wastepaper products, discarded building materials, inoperative machinery, machinery parts, and similar materials shall not be stored or maintained on private property.

(3)Overhanging or overhead objects which are loose, insecurely fastened or otherwise constitute a danger of falling on persons or property by reason of their location above the ground shall not be stored or maintained on private property.

Therefore, if the action(s) specified in this notice is not completed by 8:00 am of the re-inspection date listed, the City will take legal action concerning this violation(s). This action may include the issuance of a citation and imposition of a fine of up to two hundred fifty dollars (\$250) per day.



Sec. 14-70. - Same—General maintenance.

The exterior of every structure or accessory structure (including fences, signs, screens and store fronts) shall be maintained in good repair, termite free and all surfaces thereof shall be kept painted or have similar protective coating where necessary for purpose of preservation and appearance. All surfaces shall be maintained free of broken glass, loose shingles, crumbling stone or brick, excessive peeling paint or other condition reflective of deterioration or inadequate maintenance to the end which the property itself may be preserved, safety and fire hazards eliminated, and adjoining properties will be protected from conditions which tend to decrease the property values of surrounding properties.

Sec. 110-446. - Applicability of division.

This division applies to all fences, hedges, and walls that are not specifically exempted from this division. This division does not apply to seawalls (see chapter 14, article V of this Code for regulations on seawalls).

(7)Maintenance. After construction, fences and walls must be maintained with original components and remain substantially vertical to serve their function and aesthetic purposes. Structural integrity must be maintained to prevent a danger of destruction or flight during high winds. Hedges must be maintained at or below the maximum height permitted.

Violation Detail(s):

Building on property requiring maintenance, exterior of property requiring maintenance.
Fence on property requiring maintenance.

Corrective Action(s):

Either the property owner and/or licensed contractor will need to apply for and obtain a building permit, if required to make repairs/ modifications, to comply. If a permit cannot be obtained, the structure/changes must be removed.

Please reply with a plan of corrections before the follow-up date listed:

Follow up date:
July 30, 2024

Therefore, if the action(s) specified in this notice is not completed by 8:00 am of the re-inspection date listed, the City will take legal action concerning this violation(s). This action may include the issuance of a citation and imposition of a fine of up to two hundred fifty dollars (\$250) per day.



Grace Mills, Code Compliance Officer II
City of Madeira Beach
gmills@madeirabeachfl.gov
727-742-1645

We are now using My Government Online (MGO). Please scan the QR code below, or go to www.mgoconnect.org/cp/portal to apply online for a permit, pay fees, and schedule inspections. We are no longer accepting paper, in-person permit applications.



Therefore, if the action(s) specified in this notice is not completed by 8:00 am of the re-inspection date listed, the City will take legal action concerning this violation(s). This action may include the issuance of a citation and imposition of a fine of up to two hundred fifty dollars (\$250) per day.



6/27/2024

Therefore, if the action(s) specified in this notice is not completed by 8:00 am of the re-inspection date listed, the City will take legal action concerning this violation(s). This action may include the issuance of a citation and imposition of a fine of up to two hundred fifty dollars (\$250) per day.



6/27/2024

Therefore, if the action(s) specified in this notice is not completed by 8:00 am of the re-inspection date listed, the City will take legal action concerning this violation(s). This action may include the issuance of a citation and imposition of a fine of up to two hundred fifty dollars (\$250) per day.



6/27/2024

Therefore, if the action(s) specified in this notice is not completed by 8:00 am of the re-inspection date listed, the City will take legal action concerning this violation(s). This action may include the issuance of a citation and imposition of a fine of up to two hundred fifty dollars (\$250) per day.



6/27/2024

Therefore, if the action(s) specified in this notice is not completed by 8:00 am of the re-inspection date listed, the City will take legal action concerning this violation(s). This action may include the issuance of a citation and imposition of a fine of up to two hundred fifty dollars (\$250) per day.



6/27/2024

Therefore, if the action(s) specified in this notice is not completed by 8:00 am of the re-inspection date listed, the City will take legal action concerning this violation(s). This action may include the issuance of a citation and imposition of a fine of up to two hundred fifty dollars (\$250) per day.



6/27/2024

Therefore, if the action(s) specified in this notice is not completed by 8:00 am of the re-inspection date listed, the City will take legal action concerning this violation(s). This action may include the issuance of a citation and imposition of a fine of up to two hundred fifty dollars (\$250) per day.

PLACE STICKER AT TOP OF ENVELOPE TO THE RIGHT
OF THE RETURN ADDRESS, FOLD AT DOTTED LINE

SENDER: COMPLETE THIS SECTION

- Complete items 1, 2, and 3.
- Print your name and address on the reverse so that we can return the card to you.
- Attach this card to the back of the mailpiece, or on the front if space permits.

1. Article Addressed to:

Tucker, Blazia P
435 S Bayshore Dr
Madeira Beach FL 33708



9590 9402 7951 2305 9234 68

2. Article Number (Transfer from service label)

7019 2970 0000 5515 2809

PS Form 3811, July 2020 PSN 7530-02-000-9053

COMPLETE THIS SECTION ON DELIVERY

A. Signature

X

Agent

Addressee

B. Received by (Printed Name)

C. Date of Delivery

D. Is delivery address different from item 1? Yes
if YES, enter delivery address below: No

3. Service Type

Adult Signature

Adult Signature Restricted Delivery

Certified Mail®

Certified Mail Restricted Delivery

Collect on Delivery

Collect on Delivery Restricted Delivery

Registered Mail

Registered Mail Restricted Delivery

(over \$500)

Priority Mail Express®

Registered Mail™

Registered Mail Restricted Delivery

Signature Confirmation™

Signature Confirmation Restricted Delivery

Domestic Return Receipt



7019 2970 0000 5515 2809

Principal Drive
1, Florida 33708

TUCKER, BLAZIA P
435 S BAYSHORE DR
MADEIRA BEACH, FL 33708
Case Number: CE-24-63

TUCKER, BLAZIA P 435 S BAYSHORE DR MADEIRA BEACH, FL 33708

**CODE ENFORCEMENT SPECIAL MAGISTRATE
CITY OF MADEIRA BEACH**

January 14, 2025
City of Madeira Beach
300 Municipal Drive
Madeira Beach, Florida 33708

Petitioner,

vs.

CASE NO. CE-24-63

TUCKER, BLAZIA P
435 S BAYSHORE DR
MADEIRA BEACH, FL 33708

Respondents.

RE Property: 435 S BAYSHORE DR **Parcel #10-31-15-34380-015-0050**

Legal Description: GULF SHORES 4TH ADD BLK 0, LOT 5 LESS W 1.25FT

NOTICE OF HEARING

To whom it may concern:

YOU ARE HEREBY FORMALLY NOTIFIED that at **02:00 pm** on **MONDAY** the **27th** day of January, **2025** at the Madeira Beach City Center in the Patricia Shontz Commission Chambers, located at 300 Municipal Drive, Madeira Beach, Florida 33708, a hearing will be held before the Special Magistrate concerning the following code violation(s):

Sec. 14-69. - Same—Maintenance of the exterior of premises.

The exterior of premises and all structures thereon including but not limited to private property and vacant lots shall be kept free of all hazards to the health, safety and welfare of persons on or near the premises. It shall be the duty of the owner/occupant of such property to promptly abate or remove the same.

(1)Garbage, trash, refuse, debris, accumulations of filth, broken glass, junk, scrap metal, scrap lumber, wastepaper products, discarded building materials, inoperative machinery, machinery parts, and similar materials shall not be stored or maintained on private property.

(3)Overhanging or overhead objects which are loose, insecurely fastened or otherwise constitute a danger of falling on persons or property by reason of their location above the ground shall not be stored or maintained on private property.

Sec. 14-70. - Same—General maintenance.

The exterior of every structure or accessory structure (including fences, signs, screens and store fronts) shall be maintained in good repair, termite free and all surfaces thereof shall be kept painted or have similar protective coating where necessary for purpose of preservation and appearance. All surfaces shall be maintained free of broken glass, loose shingles, crumbling stone or brick, excessive peeling paint or other condition reflective of deterioration or inadequate maintenance to the end which the property itself may be preserved, safety and fire hazards eliminated, and adjoining properties will be protected from conditions which tend to decrease the property values of surrounding properties.

Sec. 110-446. - Applicability of division.

This division applies to all fences, hedges, and walls that are not specifically exempted from this division. This division does not apply to seawalls (see chapter 14, article V of this Code for regulations on seawalls).

(7)Maintenance. After construction, fences and walls must be maintained with original components and remain substantially vertical to serve their function and aesthetic purposes. Structural integrity must be maintained to prevent a danger of destruction or flight during high winds. Hedges must be maintained at or below the maximum height permitted.

You are hereby ordered to appear before the Special Magistrate of the City of Madeira Beach on that date and time to answer these charges and to present your side of the case. Failure to appear may result in the Special Magistrate proceeding in your absence.

Should you be found in violation of the above code, the Special Magistrate has the power by law to levy fines of up to \$250.00 per day for an initial violation(s) and \$500.00 per day for repeat violations against you and your property for every day that any violation continues beyond the date set in an order of the Special Magistrate for compliance.

If the violation is corrected and then recurs, or if the violation is not corrected by the time specified by the Code Enforcement Officer for correction, the case may still be presented to the Special Magistrate of the City of Madeira Beach even if the violation has been corrected prior to the Special Magistrate hearing.

Should you desire, you have the right to obtain an attorney at your own expense to represent you before the Special Magistrate. You will also have the opportunity to present witnesses as well as question the witnesses against you prior to the Special Magistrate making a determination.

Please be prepared to present evidence at this meeting concerning the time frame necessary to correct the alleged violation(s), should you be found in violation of the City Code.

If you wish to have any witnesses subpoenaed or have any other questions, please contact the Code Enforcement department of the City of Maderia Beach within five (5) days at 300 Municipal Drive, Maderia Beach, Florida 33708, telephone number (727) 391-9951 ext 298.

Your failure to respond to the previously issued Notice of Violation has resulted in costs of prosecution of this case.

PLEASE NOTE: Should any interested party seek to appeal any decision made by the Special Magistrate with respect to any matter considered at such meeting or hearing, he/she will need a record of the proceedings, and for such purpose, he/she may need to ensure that a verbatim record of the proceedings is made which record includes the testimony and evidence upon which the appeal is to be based per Florida Statute 286.0105.

I DO HEREBY CERTIFY that a copy of the foregoing Notice of Hearing was mailed to Respondent(s) by certified mail, return receipt requested.

Dated this 14 day of January, 2025.



Grace Mills, Code Compliance Officer
City of Madeira Beach

**CODE ENFORCEMENT SPECIAL MAGISTRATE
CITY OF MADEIRA BEACH**

January 14, 2025
City of Madeira Beach
300 Municipal Drive
Madeira Beach, Florida 33708

Petitioner,

vs.

CASE NO. CE-24-63

TUCKER, BLAZIA P
435 S BAYSHORE DR
MADEIRA BEACH, FL 33708

Respondents.

RE Property: 435 S BAYSHORE DR

Parcel #10-31-15-34380-015-0050

Legal Description: GULF SHORES 4TH ADD BLK 0, LOT 5 LESS W 1.25FT

STATEMENT OF VIOLATION/ REQUEST FOR HEARING

To whom it may concern:

During a recent review of properties on your street, it was noted that your property is in violation of the following code section(s):

Ordinance(s):

Sec. 14-69. - Same—Maintenance of the exterior of premises.

The exterior of premises and all structures thereon including but not limited to private property and vacant lots shall be kept free of all hazards to the health, safety and welfare of persons on or near the premises. It shall be the duty of the owner/occupant of such property to promptly abate or remove the same.

(1)Garbage, trash, refuse, debris, accumulations of filth, broken glass, junk, scrap metal, scrap lumber, wastepaper products, discarded building materials, inoperative machinery, machinery parts, and similar materials shall not be stored or maintained on private property.

(3)Overhanging or overhead objects which are loose, insecurely fastened or otherwise constitute a danger of falling on persons or property by reason of their location above the ground shall not be stored or maintained on private property.

Sec. 14-70. - Same—General maintenance.

The exterior of every structure or accessory structure (including fences, signs, screens and store fronts) shall be maintained in good repair, termite free and all surfaces thereof shall be kept painted or have similar protective coating where necessary for purpose of preservation and appearance. All surfaces shall be maintained free of broken glass, loose shingles, crumbling stone or brick, excessive peeling paint or other condition reflective of deterioration or inadequate maintenance to the end which the property itself may be preserved, safety and fire hazards eliminated, and adjoining properties will be protected from conditions which tend to decrease the property values of surrounding properties.

Sec. 110-446. - Applicability of division.

This division applies to all fences, hedges, and walls that are not specifically exempted from this division. This division does not apply to seawalls (see chapter 14, article V of this Code for regulations on seawalls).

(7)Maintenance. After construction, fences and walls must be maintained with original components and remain substantially vertical to serve their function and aesthetic purposes. Structural integrity must be maintained to prevent a danger of destruction or flight during high winds. Hedges must be maintained at or below the maximum height permitted.

Please bring the property into compliance by applying for and obtaining an “after-the-fact” building permit or removing unpermitted work within seven (7) days of the date of this letter. Should you fail to bring the property into compliance within seven (7) days the City will bring this case to the Special Magistrate. Please note that the Special Magistrate can levy fines up to \$250.00 per day for each day the property remains in non-compliance.

I DO HEREBY SWEAR THAT THE ABOVE FACTS ARE TRUE TO THE BEST OF MY KNOWLEDGE. I REQUEST A HEARING ON THE ABOVE VIOLATION(S) BY THE SPECIAL MAGISTRATE OF THE CITY OF MADEIRA BEACH.



**Grace Mills, Code Compliance Officer
City of Madeira Beach**

**CODE ENFORCEMENT SPECIAL MAGISTRATE
CITY OF MADEIRA BEACH**

January 14, 2025
City of Madeira Beach
300 Municipal Drive
Madeira Beach, Florida 33708

Petitioner,

vs.

CASE NO. CE-24-63

TUCKER, BLAZIA P
435 S BAYSHORE DR
MADEIRA BEACH, FL 33708

Respondents.

RE Property: 435 S BAYSHORE Parcel #10-31-15-34326-007-0060

Legal Description: GULF SHORES 4TH ADD BLK 0, LOT 5 LESS W 1.25 FT

AFFIDAVIT OF SERVICE

I, Grace Mills, Building Code Compliance Officer II of the City of Madeira Beach, upon being duly sworn, deposed and says the following:

That pursuant to Florida Statute 162.12,

On the 14 day of January, 2025, I mailed a copy of the attached NOTICE OF HEARING via Certified Mail, Return Receipt Requested.

On the 14 day of January, 2025, I mailed a copy of the attached NOTICE OF HEARING via First Class mail.

On the 14 day of January, 2025, I posted a copy of the attached NOTICE OF HEARING on the property located at 435 S Bayshore, Parcel # 10-31-15-34326-007-0060 the City of Madeira Beach.

On the 14 day of January, 2025, I caused the attached NOTICE OF HEARING to be posted at the Municipal Government Offices, 300 Municipal Drive, Madeira Beach; and that said papers remain posted at the Municipal Government Offices for a period of not less than ten days from the date of posting.

Grace Mills
Grace Mills, Code Compliance Officer
City of Madeira Beach

STATE OF FLORIDA
COUNTY OF PINELLAS

The foregoing instrument was acknowledged before me, the undersigned authority, by means of 0 physical presence or online notarization, this 14 day of January, 2025, by Grace Mills, who is personally known to me, or produced as identification. My Commission Expires: 03-15-27

Notary Public- State of Florida

Samantha Arison
Print or type Name. Samantha Arison

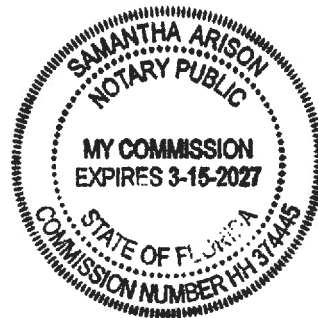

CERTIFIED MAIL



Municipal Drive
Madeira Beach, Florida 33708



7022 3330 0000 7447 7739



quadiant
FIRST-CLASS MAIL
IMI
\$009.64⁰
01/14/2025 ZIP 33708
043M31233717

US POSTAGE

TUCKER, BLAZIA P
435 S BAYSHORE DR
MADEIRA BEACH, FL 33708

Respondents.

SENDER: COMPLETE THIS SECTION

- Complete items 1, 2, and 3.
- Print your name and address on the reverse so that we can return the card to you.
- Attach this card to the back of the mailpiece, or on the front if space permits.

1. Article Addressed to:

Tucker, Blazia
435 S Bayshore Dr
Madera Beach Fl 33708



9590 9402 7951 2305 9229 04

2. Article Number (Transfer from service label)

7022 3330 0000 7447 7739

COMPLETE THIS SECTION ON DELIVERY

A. Signature

X

Agent

Addressee

B. Received by (Printed Name)

C. Date of Delivery

D. Is delivery address different from item 1? Yes
If YES, enter delivery address below: No

3. Service Type

- Adult Signature
- Adult Signature Restricted Delivery
- Certified Mail®
- Certified Mail Restricted Delivery
- Collect on Delivery
- Collect on Delivery Restricted Delivery
- Priority Mail Express®
- Registered Mail™
- Registered Mail Restricted Delivery
- Signature Confirmation™
- Signature Confirmation Restricted Delivery

Mail Restricted Delivery (0)

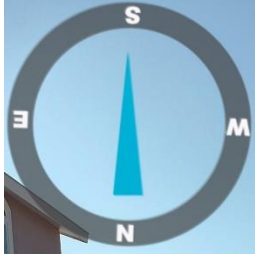

Jan 14, 2025 9:55:33 AM
174° S
435 South Bayshore Drive
Madeira Beach
Pinellas County
Florida

jūju
Index number: 580

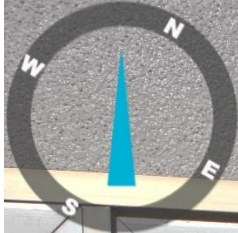

Madiera Beach
FLORIDA

MEETING NOTICES

CODE ENFORCEMENT SPECIAL MAGISTRATE
CITY OF MADIERA BEACH

January 14, 2025
City of Madiera Beach
300 Municipal Drive
Madiera Beach, Florida 32708

Palmetto:

vs.

CASE NO. CE-24-7

TUCKER, BLANDA P
4375 BAYSHORE DR
MADIERA BEACH, FL 32708

Respondent:

RE Property: 4375 BAYSHORE DR Parcel #10741543004154004

Legal Description: C.E.F. SHORES 4TH ADD BLK. 4, LOT 4 EENS W 1207

NOTICE OF HEARING

To whom it may concern:

YOU ARE HEREBY FORMALLY NOTICED that at 12:00 pm on MONDAY the 27th day of January, 2025 at the Madiera Beach City Center in the Public Works Commission Chambers, located at 300 Municipal Drive, Madiera Beach, Florida 32708, a hearing will be held before the Special Magistrate concerning the following code violation(s):

Sec. 14.09 - Signs - Maintenance of the exterior of premises.

The presence of persons and all materials therein, including but not limited to private property and contents, may affect the health, safety and welfare of citizens or of any other persons, it shall be the duty of the owner/manager of such premises to promptly clean or remove the same.

(1) Signs, trash, refuse, debris, accumulation of dirt, fire arm shells, ash, worn paint, scrap building, appliance, furniture, discarded building materials, unexcused enclosures, machinery parts, and similar materials shall not be stored or maintained on private property.

(2) Improvements or structural alterations which have been, are being, or will be made, constitute a hazard of injury, or persons or property, in cases of such location where the ground, shall not be stored or maintained on private property.

Page 1 of 3

CODE ENFORCEMENT SPECIAL MAGISTRATE
CITY OF MADIERA BEACH

January 14, 2025
City of Madiera Beach
300 Municipal Drive
Madiera Beach, Florida 32708

Palmetto:

vs.

CASE NO. CE-24-7

AYOORAN ENVIROMENT GROUP LLC
2075 ECHO CANY DR UNIT 210
CLEARWATER, FL 34616

Respondent:

RE Property: 14111 E PARLEY DR Parcel #107415434025141004

Legal Description: C.E.F. SHORES 4TH ADD REPLAT BLK W 1 LOT 9

NOTICE OF HEARING

To whom it may concern:

YOU ARE HEREBY FORMALLY NOTICED that at 12:00 pm on MONDAY the 27th day of January, 2025 at the Madiera Beach City Center in the Public Works Commission Chambers, located at 300 Municipal Drive, Madiera Beach, Florida 32708, a hearing will be held before the Special Magistrate concerning the following code violation(s):

Sec. 14.52 - When required.

A permit, form or incorporation shall not constitute, indicate, allow, repair, erect, demolish, or change the occupancy of a building or structure, or erect, or construct a sign, or install or alter fire extinguishing apparatus, alarms, registers, smoke detectors, firework, automatic or other fire protecting apparatus, plumbing, mechanical or electrical equipment or any other equipment, the installation of which is regulated by the land development regulations or other sections of the Code until a permit has been issued by the building official. When the cost of repair or modification does not exceed \$100.00, does not result in a structural change, and does not require an engineering or professional seal to be issued by the building official, no permit is required for reconstructing flat roofs of no greater than 50 square feet, for work of

Page 1 of 3

NOTICE OF PUBLIC HEARING OF
AMENDMENTS TO THE CITY LAND DEVELOPMENT REGULATIONS AND TO
REGULATIONS FOR THE PUBLIC WORKS ACTIVITY CENTER, C-1 ZONING DISTRICT, AND
CONSTRUCTION, RETAIL COMMERCIAL, C-1 ZONING DISTRICT, PLANNED
COMMERCIAL, C-1 ZONING DISTRICT, AND PLANNED COMMERCIAL, C-1 ZONING
DISTRICT IN THE MADIERA BEACH CITY CENTER, 300 MUNICIPAL DRIVE, MADIERA BEACH, FLORIDA

The City of Madiera Beach is holding a public hearing on the proposed amendments to the City Land Development Regulations and to Regulations for the Public Works Activity Center, C-1 Zoning District, and Construction, Retail Commercial, C-1 Zoning District, Planned Commercial, C-1 Zoning District, and Planned Commercial, C-1 Zoning District in the Madiera Beach City Center, 300 Municipal Drive, Madiera Beach, Florida. The hearing will be held on Monday, January 27, 2025, at 12:00 pm. The hearing will be held in the Public Works Commission Chambers, located at 300 Municipal Drive, Madiera Beach, Florida 32708.

The proposed amendments include changes to the definitions of "Accessory Use," "C-1 Zoning District," "Construction, Retail Commercial, C-1 Zoning District," "Planned Commercial, C-1 Zoning District," and "Planned Commercial, C-1 Zoning District." The amendments also include changes to the use regulations and the lot coverage regulations for the C-1 Zoning District, the Construction, Retail Commercial, C-1 Zoning District, the Planned Commercial, C-1 Zoning District, and the Planned Commercial, C-1 Zoning District.

The City of Madiera Beach is a city of the first class under the Florida Constitution. The City is governed by a Mayor and a City Commission. The City Commission is the governing body of the City and has the authority to adopt, amend, or repeal any ordinance, resolution, or other act of the City. The City Commission is also responsible for the overall management and administration of the City.

The proposed amendments are necessary to ensure that the City's land development regulations are up-to-date and reflect the current needs of the City. The amendments are also necessary to ensure that the City's land development regulations are consistent with the Florida Constitution and the Florida Statutes.

Any person who wishes to speak at the hearing should contact the City Manager's Office at (904) 848-1234. The City Manager's Office is located at 300 Municipal Drive, Madiera Beach, Florida 32708.

Page 1 of 3

Jan 14, 2025 10:54:40 AM
330° NW
300 Municipal Drive
Madiera Beach
Pinellas County
Florida

juju
Index number: 582