

## Thomas Trask

---

**From:** Grace Mills <GMills@madeirabeachfl.gov>  
**Sent:** Monday, January 22, 2024 10:59 AM  
**To:** tov@vestgaarden.com  
**Cc:** Pinkard, Holden; Robin Gomez; DeSantis, Frank; Thomas Trask  
**Subject:** RE: Hearing tomorrow

Mr. Vestgaarden,

Your case will be moved to be heard Monday, February 26, at 2:00PM. For any questions or concerns, please feel free to contact me via email or phone.

*Thank you,*

*Grace Mills*

Code Compliance Officer II  
City of Madeira Beach  
300 Municipal Dr. I (727) 391-9951 x298  
[www.Madeirabeachfl.gov](http://www.Madeirabeachfl.gov)



**We are now using My Government Online (MGO). Click Here or scan QR Code to apply online for a permit, pay fees, and schedule inspections.**



Disclaimer: Under Florida law (Florida Statute 668.6076), email addresses are public records. If you do not want your email address released in response to a public records request, please do not send electronic mail to the City of Madeira Beach. Instead, contact the appropriate department/division.

**From:** Tov Vestgaarden <[vestgaarden@gmail.com](mailto:vestgaarden@gmail.com)>  
**Sent:** Sunday, January 21, 2024 4:50 PM  
**To:** Robin Gomez <[RGomez@madeirabeachfl.gov](mailto:RGomez@madeirabeachfl.gov)>  
**Cc:** Tom Trask <[tom@cityattorneys.legal](mailto:tom@cityattorneys.legal)>; Pinkard, Holden <[HPinkard@madeirabeachfl.gov](mailto:HPinkard@madeirabeachfl.gov)>  
**Subject:** Re: Hearing tomorrow

CAUTION: This email originated from outside your organization. Exercise caution when opening attachments or clicking links, especially from unknown senders.

Thank you Robin!

On Sun, Jan 21, 2024, 2:00 PM Robin Gomez <[RGomez@madeirabeachfl.gov](mailto:RGomez@madeirabeachfl.gov)> wrote:

I cannot provide you an answer. I am copying our building and legal staff who will advise you tomorrow morning at the latest.

Thanks.  
Robin I. Gomez  
Madeira Beach City Manager  
727.580.8014

---

**From:** Tov Vestgaarden <[vestgaarden@gmail.com](mailto:vestgaarden@gmail.com)>  
**Sent:** Sunday, January 21, 2024 1:49:58 PM  
**To:** Robin Gomez <[RGomez@madeirabeachfl.gov](mailto:RGomez@madeirabeachfl.gov)>  
**Subject:** Hearing tomorrow

CAUTION: This email originated from outside your organization. Exercise caution when opening attachments or clicking links, especially from unknown senders.

Robin,

I hope all is well.

I work in the medical field and have a work related emergency. I will not be able to attend the hearing tomorrow. Can my part of the hearing be postponed till the next meeting?

Best regards,  
Tov

Disclaimer: Under Florida law (Florida Statute 668.6076), email addresses are public records. If you do not want your email address released in response to a public records request, please do not send electronic mail to the City of Madeira Beach. Instead, contact the appropriate department/division.

Disclaimer: Under Florida law (Florida Statute 668.6076), email addresses are public records. If you do not want your email address released in response to a public records request, please do not send electronic mail to the City of Madeira Beach. Instead, contact the appropriate department/division.

**Disclaimer: Under Florida law (Florida Statute 668.6076), email addresses are public records. If you do not want your email address released in response to a public records request, please do not send electronic mail to the City of Madeira Beach. Instead, contact the appropriate department/division.**

**Disclaimer: Under Florida law (Florida Statute 668.6076), email addresses are public records. If you do not want your email address released in response to a public records request, please do not send electronic mail to the City of Madeira Beach. Instead, contact the appropriate department/division.**

**Disclaimer: Under Florida law (Florida Statute 668.6076), email addresses are public records. If you do not want your email address released in response to a public records request, please do not send electronic mail to the City of Madeira Beach. Instead, contact the appropriate department/division.**

**Disclaimer: Under Florida law (Florida Statute 668.6076), email addresses are public records. If you do not want your email address released in response to a public records request, please do not send electronic mail to the City of Madeira Beach. Instead, contact the appropriate department/division.**

**Disclaimer: Under Florida law (Florida Statute 668.6076), email addresses are public records. If you do not want your email address released in response to a public records request, please do not send electronic mail to the City of Madeira Beach. Instead, contact the appropriate department/division.**

CODE ENFORCEMENT SPECIAL MAGISTRATE  
CITY OF MADEIRA BEACH

CITY OF MADEIRA BEACH,

CASE NUMBER: 2022.3526

Petitioner,

vs.

VESTGAARDEN, TOV I.,  
590 Normandy Rd.  
Madeira Beach, FL 33708,

Respondent.

ORDER OF CONTINUANCE

THIS CAUSE came on to be heard for public hearing before the undersigned Special Magistrate on January 22, 2024, after due notice to the Respondent, and the Special Magistrate being advised in the premises:

IT IS ORDERED AND ADJUDGED AS FOLLOWS:

1. The City's request to continue the hearing is hereby GRANTED.
2. This matter shall be continued to the hearing on **February 26, 2024, at 2:00 p.m.**, at 300 Municipal Drive, Madeira Beach, Florida 33708.

DONE AND ORDERED this 6<sup>th</sup> day of February, 2024.

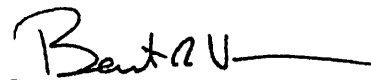

\_\_\_\_\_  
Bart R. Valdes  
Special Magistrate

Copies furnished to:

Thomas Trask, City Attorney

Clara VanBlargan, City of Madeira Beach

Holden Pinkard, Building Dept. Operations Coordinator

Tov I. Vestgaarden  
590 Normandy Rd.  
Madeira Beach, FL 33708

## Thomas Trask

---

**From:** Tov Vestgaarden <vestgaarden@gmail.com>  
**Sent:** Tuesday, February 20, 2024 9:23 AM  
**To:** Grace Mills  
**Cc:** Pinkard, Holden; Thomas Trask; Robin Gomez; DeSantis, Frank  
**Subject:** Re: Hearing tomorrow  
**Attachments:** DFW TPA.jpg; TPA AUS.jpg

Grace,

My lawyer asked me to reach out to you. He will not be in town for the hearing on Monday. Is there any way we can get this postponed to the next meeting?

Please see my tickets attached to this e-mail. Austin on Saturday and return from Dallas on Wednesday.

Best regards,  
Tov

On Tue, Feb 6, 2024 at 2:41 PM Tov Vestgaarden <[vestgaarden@gmail.com](mailto:vestgaarden@gmail.com)> wrote:  
Grace,

Thank you for your response.

Robin already told me that the Magistrate would tell me to tear it down, to which I responded: "Is there even a point in me going". Robin continued to explain that it is a process and that I needed to be there. Unfortunately I will be out of town, so I can't be at two places at once.

Best regards,  
Tov

On Tue, Feb 6, 2024 at 1:52 PM Grace Mills <[GMills@madeirabeachfl.gov](mailto:GMills@madeirabeachfl.gov)> wrote:

Mr. Vestgaarden,

Thank you for your email, the City cannot support another continuance of this violation, and the mentioned case will remain on the agenda for February 26<sup>th</sup> at 02:00PM.

*Sincerely,*

## *Grace Mills*

Code Compliance Officer II

City of Madeira Beach

300 Municipal Dr. I (727) 391-9951 x298

[www.Madeirabeachfl.gov](http://www.Madeirabeachfl.gov)



**We are now using My Government Online (MGO). Click Here or scan QR Code to apply online for a permit, pay fees, and schedule inspections.**



Disclaimer: Under Florida law (Florida Statute 668.6076), email addresses are public records. If you do not want your email address released in response to a public records request, please do not send electronic mail to the City of Madeira Beach. Instead, contact the appropriate department/division.

---

**From:** Tov Vestgaarden <[vestgaarden@gmail.com](mailto:vestgaarden@gmail.com)>  
**Sent:** Friday, February 2, 2024 7:33 AM  
**To:** Grace Mills <[GMills@madeirabeachfl.gov](mailto:GMills@madeirabeachfl.gov)>  
**Subject:** Re: Hearing tomorrow

CAUTION: This email originated from outside your organization. Exercise caution when opening attachments or clicking links, especially from unknown senders.

Grace,

Thank you for understanding and for moving my hearing. Unfortunately, I will be in Texas for business on February 26th.

Best regards,

Tov

On Mon, Jan 22, 2024 at 10:59 AM Grace Mills <[GMills@madeirabeachfl.gov](mailto:GMills@madeirabeachfl.gov)> wrote:

Mr. Vestgaarden,

Your case will be moved to be heard Monday, February 26, at 2:00PM. For any questions or concerns, please feel free to contact me via email or phone.

*Thank you,*

## Grace Mills

Code Compliance Officer II

City of Madeira Beach

300 Municipal Dr. I (727) 391-9951 x298

[www.Madeirabeachfl.gov](http://www.Madeirabeachfl.gov)



**We are now using My Government Online (MGO). Click Here or scan QR Code to apply online for a permit, pay fees, and schedule inspections.**



Disclaimer: Under Florida law (Florida Statute 668.6076), email addresses are public records. If you do not want your email address released in response to a public records request, please do not send electronic mail to the City of Madeira Beach. Instead, contact the appropriate department/division.



---

**From:** Tov Vestgaarden <[vestgaarden@gmail.com](mailto:vestgaarden@gmail.com)>  
**Sent:** Sunday, January 21, 2024 4:50 PM  
**To:** Robin Gomez <[RGomez@madeirabeachfl.gov](mailto:RGomez@madeirabeachfl.gov)>  
**Cc:** Tom Trask <[tom@cityattorneys.legal](mailto:tom@cityattorneys.legal)>; Pinkard, Holden <[HPinkard@madeirabeachfl.gov](mailto:HPinkard@madeirabeachfl.gov)>  
**Subject:** Re: Hearing tomorrow

CAUTION: This email originated from outside your organization. Exercise caution when opening attachments or clicking links, especially from unknown senders.

Thank you Robin!

On Sun, Jan 21, 2024, 2:00 PM Robin Gomez <[RGomez@madeirabeachfl.gov](mailto:RGomez@madeirabeachfl.gov)> wrote:

I cannot provide you an answer. I am copying our building and legal staff who will advise you tomorrow morning at the latest.

Thanks.

Robin I. Gomez

Madeira Beach City Manager

727.580.8014

---

**From:** Tov Vestgaarden <[vestgaarden@gmail.com](mailto:vestgaarden@gmail.com)>  
**Sent:** Sunday, January 21, 2024 1:49:58 PM  
**To:** Robin Gomez <[RGomez@madeirabeachfl.gov](mailto:RGomez@madeirabeachfl.gov)>  
**Subject:** Hearing tomorrow

CAUTION: This email originated from outside your organization. Exercise caution when opening attachments or clicking links, especially from unknown senders.

Robin,

I hope all is well.

I work in the medical field and have a work related emergency. I will not be able to attend the hearing tomorrow. Can my part of the hearing be postponed till the next meeting?

Best regards,

Tov

Disclaimer: Under Florida law (Florida Statute 668.6076), email addresses are public records. If you do not want your email address released in response to a public records request, please do not send electronic mail to the City of Madeira Beach. Instead, contact the appropriate department/division.

Disclaimer: Under Florida law (Florida Statute 668.6076), email addresses are public records. If you do not want your email address released in response to a public records request, please do not send electronic mail to the City of Madeira Beach. Instead, contact the appropriate department/division.

Disclaimer: Under Florida law (Florida Statute 668.6076), email addresses are public records. If you do not want your email address released in response to a public records request, please do not send electronic mail to the City of Madeira Beach. Instead, contact the appropriate department/division.

Disclaimer: Under Florida law (Florida Statute 668.6076), email addresses are public records. If you do not want your email address released in response to a public records request, please do not send electronic mail to the City of Madeira Beach. Instead, contact the appropriate department/division.

Disclaimer: Under Florida law (Florida Statute 668.6076), email addresses are public records. If you do not want your email address released in response to a public records request, please do not send electronic mail to the City of Madeira Beach. Instead, contact the appropriate department/division.

Disclaimer: Under Florida law (Florida Statute 668.6076), email addresses are public records. If you do not want your email address released in response to a public records request, please do not send electronic mail to the City of Madeira Beach. Instead, contact the appropriate department/division.

Disclaimer: Under Florida law (Florida Statute 668.6076), email addresses are public records. If you do not want your email address released in response to a public records request, please do not send electronic mail to the City of Madeira Beach. Instead, contact the appropriate department/division.

Disclaimer: Under Florida law (Florida Statute 668.6076), email addresses are public records. If you do not want your email address released in response to a public records request, please do not send electronic mail to the City of Madeira Beach. Instead, contact the appropriate department/division.

Disclaimer: Under Florida law (Florida Statute 668.6076), email addresses are public records. If you do not want your email address released in response to a public records request, please do not send electronic mail to the City of Madeira Beach. Instead, contact the appropriate department/division.

Disclaimer: Under Florida law (Florida Statute 668.6076), email addresses are public records. If you do not want your email address released in response to a public records request, please do not send electronic mail to the City of Madeira Beach. Instead, contact the appropriate department/division.

Disclaimer: Under Florida law (Florida Statute 668.6076), email addresses are public records. If you do not want your email address released in response to a public records request, please do not send electronic mail to the City of Madeira Beach. Instead, contact the appropriate department/division.

Disclaimer: Under Florida law (Florida Statute 668.6076), email addresses are public records. If you do not want your email address released in response to a public records request, please do not send electronic mail to the City of Madeira Beach. Instead, contact the appropriate department/division.

Disclaimer: Under Florida law (Florida Statute 668.6076), email addresses are public records. If you do not want your email address released in response to a public records request, please do not send electronic mail to the City of Madeira Beach. Instead, contact the appropriate department/division.

Disclaimer: Under Florida law (Florida Statute 668.6076), email addresses are public records. If you do not want your email address released in response to a public records request, please do not send electronic mail to the City of Madeira Beach. Instead, contact the appropriate department/division.

# Concur Itinerary 02/24/2024: TRIP FROM TAMPA TO AUSTIN (3VUVWI)



Concur Travel <TravelWizard@concur.com>  
To: Tov Vestgaarden

If there are problems with how this message is displayed, click here to view it in a web browser.  
Click here to download pictures. To help protect your privacy, Outlook prevented automatic download of some pictures in this message.

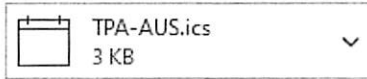

Outlook found new events



Departs: Tampa (TPA), Sat, Feb 24 1:00 PM  
Arrives: Austin (AUS), Sat, Feb 24 2:45 PM

---

View in calendar    Check in

**Flight to Austin**

Southwest Airlines 496  
Confirmation Code: 3VUVWI  
2 hrs 45 min

Translate message to: Swedish    Never translate from: English    Translation preferences

## Trip Overview

**Trip Name:** Trip from Tampa to Austin

**Start Date:** February 24, 2024

**End Date:** February 24, 2024

**Created:** February 14, 2024, Tov Vestgaarden (Modified: February 14, 2024)

**Description:** (No Description Available)

**Agency Record Locator:** 3VUVWI

**Passengers:** Tov I Vestgaarden

**Total Estimated Cost:** \$245.98 USD

Airfare must be ticketed by: 02/14/2024 11:00 PM Eastern

**Agency Name:** Gant Travel INDG22108 (No BE)  
**Address:**  
304 W Kirkwood Ave. - Suite 101  
Bloomington, IN 47404  
Phone: 630-227-3800  
Email for Online Support: [clientservices@ganttravel.com](mailto:clientservices@ganttravel.com) or call 630-227-3825  
Email for reservations: [TravelSupport@ganttravel.com](mailto:TravelSupport@ganttravel.com) After hours: 877-924-0303  
Daytime Phone: 630-227-3800  
Nighttime Phone: 877-924-0303

You can check in via the American app 24 hours before your flight and get your mobile boarding pass.

Confirmation code: **HOKGMM**

**Wednesday, February 28, 2024**

**DFW**

Dallas/Fort Worth

**8:36 AM**

**AA 1650**

**TPA**

Tampa

**12:02 PM**

Seat: **3F**

Class: **Business (J)**

Meals: **Breakfast**

[Manage your trip](#)

**Earn 50,000 bonus miles**

Plus great travel benefits. Terms Apply.

[Learn more](#)



## Your purchase

Tov Vestgaarden - AAAdvantage® #: 900\*\*\*\*

# 10-31-15-43272-000-0430

## Compact Property Record Card

[Tax Estimator](#)

**Updated July 18, 2023**

[Email Print](#)

[Radius Search](#)

[FEMA/WLM](#)

<b>Ownership/Mailing Address</b> <a href="#">Change Mailing Address</a>	<b>Site Address</b>
VESTGAARDEN, TOVI 590 NORMANDY RD MADEIRA BEACH FL 33708-2343	590 NORMANDY RD MADEIRA BEACH



**Property Use:** 0110 (Single Family Home) **Current Tax District:** MADEIRA BEACH (MB) **Total Living:** SF: 1,538 **Total Gross SF:** 2,544 **Total Living Units:** 1

[click here to hide] **Legal Description**

ISLAND ESTATES UNIT NO. 1 N 1/2 LOT 43 & S 49 FT OF LOT 42

<b>Tax Estimator</b> <a href="#">File for Homestead Exemption</a>	<b>2023 Parcel Use</b>	
<b>Exemption</b>	<b>2023</b>	<b>2024</b>
Homestead:	Yes	Yes
Government:	No	No
Institutional:	No	No
Historic:	No	No
*Assuming no ownership changes before Jan. 1		
Homestead Use Percentage: 100.00%		
Non-Homestead Use Percentage: 0.00%		
Classified Agricultural: No		

**Parcel Information** [Latest Notice of Proposed Property Taxes \(TRIM Notice\)](#)

Most Recent Recording	Sales Comparison	Census Tract	Evacuation Zone (NOT the same as a FEMA Flood Zone)	Flood Zone (NOT the same as your evacuation zone)	Plat Book/Page
15679/2566	\$1,083,400 <a href="#">Sales Query</a>	121030278022	A	<a href="#">Current FEMA Maps</a>	25/19

**2023 Preliminary Value Information**

Year	Just/Market Value	Assessed Value / SOH Cap	County Taxable Value	School Taxable Value	Municipal Taxable Value
2023	\$944,498	\$397,105	\$347,105	\$372,105	\$347,105

[click here to hide] **Value History as Certified (yellow indicates correction on file)**

Year	Homestead Exemption	Just/Market Value	Assessed Value	County Taxable Value	School Taxable Value	Municipal Taxable Value
2022	Yes	\$816,811	\$385,539	\$335,539	\$360,539	\$335,539
2021	Yes	\$633,672	\$374,310	\$324,310	\$349,310	\$324,310
2020	Yes	\$524,820	\$369,142	\$319,142	\$344,142	\$319,142
2019	Yes	\$498,405	\$360,843	\$310,843	\$335,843	\$310,843
2018	Yes	\$487,915	\$354,115	\$304,115	\$329,115	\$304,115
2017	Yes	\$446,019	\$337,754	\$287,754	\$312,754	\$287,754
2016	Yes	\$392,761	\$302,184	\$252,184	\$277,184	\$252,184
2015	Yes	\$352,148	\$300,083	\$250,083	\$275,083	\$250,083
2014	Yes	\$317,737	\$297,701	\$247,701	\$272,701	\$247,701
2013	Yes	\$320,988	\$293,301	\$243,301	\$268,301	\$243,301
2012	Yes	\$300,998	\$288,398	\$238,398	\$263,398	\$238,398
2011	Yes	\$279,998	\$279,998	\$229,998	\$254,998	\$229,998
2010	Yes	\$305,782	\$305,782	\$255,782	\$280,782	\$255,782
2009	Yes	\$389,728	\$389,728	\$339,728	\$364,728	\$339,728
2008	Yes	\$462,400	\$462,400	\$412,400	\$437,400	\$412,400
2007	Yes	\$512,700	\$449,855	\$424,855	N/A	\$424,855
2006	Yes	\$557,000	\$438,883	\$413,883	N/A	\$413,883
2005	Yes	\$426,100	\$426,100	\$401,100	N/A	\$401,100
2004	No	\$376,500	\$376,500	\$376,500	N/A	\$376,500
2003	No	\$307,100	\$307,100	\$307,100	N/A	\$307,100
2002	No	\$258,400	\$258,400	\$258,400	N/A	\$258,400
2001	No	\$189,900	\$189,900	\$189,900	N/A	\$189,900
2000	No	\$167,700	\$167,700	\$167,700	N/A	\$167,700
1999	No	\$146,300	\$146,300	\$146,300	N/A	\$146,300
1998	No	\$149,100	\$149,100	\$149,100	N/A	\$149,100
1997	No	\$139,000	\$139,000	\$114,000	N/A	\$114,000
1996	Yes	\$137,300	\$137,300	\$112,300	N/A	\$112,300

**2022 Tax Information**

<a href="#">2022 Tax Bill</a>	Tax District: MB
2022 Final Millage Rate	16.2571
<b>Do not rely on current taxes as an estimate following a change in ownership. A significant change in taxable value may occur after a transfer due to a loss of</b>	

**Ranked Sales** (What are Ranked Sales?), [See all transactions](#)

Sale Date	Book/Page	Price	Q/U	V/I
12 Mar 2007	15679 / 2566	\$550,000	Q	I
05 Jun 1997	09731 / 1112	\$179,000	Q	I
29 May 1996	09355 / 1933	\$29,000	U	I
02 May 1988	06734 / 1166	\$1,000	U	

[exemptions, reset of the Save Our Homes or 10% Cap, and/or market conditions.](#)

Please use our new [Tax Estimator](#) to estimate taxes under new ownership-2023 Land Information

Seawall: Yes

Frontage: Canal/River

View: None

<a href="#">Land Use</a>	<a href="#">Land Size</a>	<a href="#">Unit Value</a>	<a href="#">Units</a>	<a href="#">Total Adjustments</a>	<a href="#">Adjusted Value</a>	<a href="#">Method</a>
Single Family (01)	77x120	13500.00	77.0000	1.0593	\$1,101,142	FF

[\[click here to hide\] 2023 Building 1 Structural Elements](#) [Back to Top](#)

Site Address: 590 NORMANDY RD

Building Type: **Single Family**  
 Quality: **Average**  
 Foundation: **Continuous Footing Poured**  
 Floor System: **Slab On Grade**  
 Exterior Wall: **Cb Stucco/Cb Reclad**  
 Roof Frame: **Gable Or Hip**  
 Roof Cover: **Shingle Composition**  
 Stories: **1**  
 Living units: **1**  
 Floor Finish: **Carpet/Hardtile/Hardwood**  
 Interior Finish: **Drywall/Plaster**  
 Fixtures: **6**  
 Year Built: **1955**  
 Effective Age: **45**  
 Heating: **Central Duct**  
 Cooling: **Cooling (Central)**

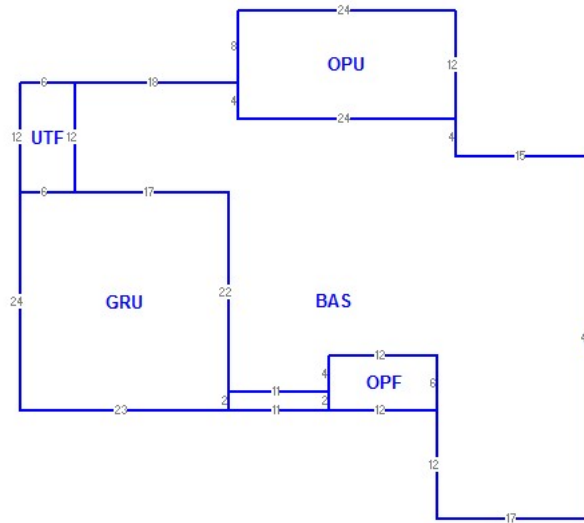

[Compact Property Record Card](#)

[Open plot in New Window](#)

**Building 1 Sub Area Information**

<a href="#">Description</a>	<a href="#">Living Area SF</a>	<a href="#">Gross Area SF</a>
<a href="#">Garage Unfinished (GRU)</a>	0	552
<a href="#">Base (BAS)</a>	1,538	1,538
<a href="#">Open Porch (OPF)</a>	0	72
<a href="#">Open Porch Unfinished (OPU)</a>	0	310
<a href="#">Utility (UTF)</a>	0	72
Total Living SF: <b>1,538</b>		Total Gross SF: <b>2,544</b>

[\[click here to hide\] 2023 Extra Features](#)

Description	Value/Unit	Units	Total Value as New	Depreciated Value	Year
PORCH	\$12.00	289.00	\$3,468.00	\$3,468.00	2020
BT LFT/DAV	\$16,000.00	1.00	\$16,000.00	\$8,000.00	2003
DOCK	\$56.00	530.00	\$29,680.00	\$25,525.00	2017
BT LFT/DAV	\$3,500.00	1.00	\$3,500.00	\$1,750.00	2003
PATIO/DECK	\$22.00	185.00	\$4,070.00	\$3,378.00	2016
SPA/JAC/HT	\$16,000.00	1.00	\$16,000.00	\$13,280.00	2016
POOL	\$55,000.00	1.00	\$55,000.00	\$45,650.00	2016

[\[click here to hide\] Permit Data](#)

Permit information is received from the County and Cities. This data may be incomplete and may exclude permits that do not result in field reviews (for example for water heater replacement permits). We are required to list all improvements, which may include unpermitted construction. Any questions regarding permits, or the status of non-permitted improvements, should be directed to the permitting jurisdiction in which the structure is located.

Permit Number	Description	Issue Date	Estimated Value
DEMO20230446	DEMOLITION	08 Jun 2023	\$935
P47461-17	DOCK	01 Apr 2018	\$0
P47461-17REV	DOCK	01 Feb 2018	\$0
D2003	BOAT LIFT/DAVIT	17 Oct 2017	\$29,275
DOCK	DOCK	12 Oct 2017	\$0
BR1743	MISCELLANEOUS	11 Jul 2017	\$2,000
487	POOL	20 Apr 2016	\$40,000
92	ROOF	07 Dec 2015	\$7,200
P3509804	DOCK	25 Jan 2005	\$0
P3154402	DOCK	28 May 2002	\$0
P3150402	DOCK	28 May 2002	\$0
<a href="#">PER-H-CB249266</a>	MISCELLANEOUS	08 Feb 2002	\$19,800
<a href="#">PER-H-CB240524</a>	MISCELLANEOUS	14 Aug 2001	\$1,729

P2721299	DOCK	02 Jun 1999	\$0
<a href="#">PER-H-CB197201</a>	DOCK	21 May 1999	\$4,150

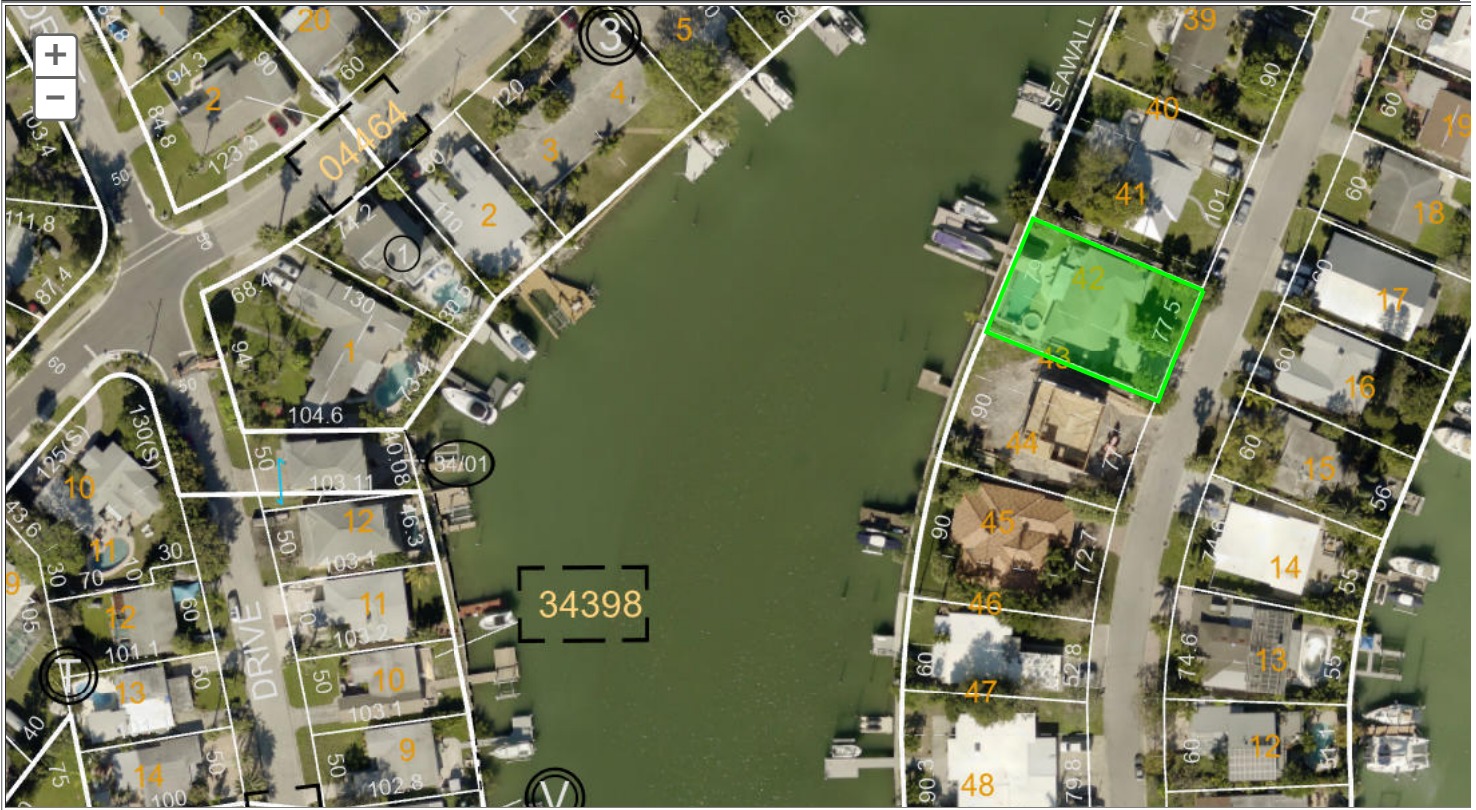

If you are experiencing [issues with this map loading](#), you may need to clear your web browsing history, then close

[Interactive Map of this parcel](#)

[Map Legend](#)

[Sales Query](#)

[Back to Query Results](#)

[New Search](#)

[Tax Collector Home Page](#)

[Contact Us](#)



[Search](#) > Account Summary

## Real Estate Account #R115825

**Owner:**

VESTGAARDEN, TOVI

**Situs:**
590 NORMANDY RD  
MADEIRA BEACH
[Parcel details](#)
[Property Appraiser](#)
 Homestead Exemption

[Get bills by email](#)

## Amount Due

Your account is **paid in full**. There is nothing due at this time.

Your last payment was made on **11/22/2022** for **\$5,379.81**.

## Account History

BILL	AMOUNT DUE	STATUS	ACTION
<a href="#">2022 Annual Bill</a> ⓘ	\$0.00	<b>Paid</b> \$5,379.81 11/22/2022	<b>Receipt</b> #0-22-142662 <a href="#">Print (PDF)</a>
<a href="#">2021 Annual Bill</a> ⓘ	\$0.00	<b>Paid</b> \$5,480.82 11/17/2021	<b>Receipt</b> #0-21-122751 <a href="#">Print (PDF)</a>
<a href="#">2020 Annual Bill</a> ⓘ	\$0.00	<b>Paid</b> \$5,479.62 11/23/2020	<b>Receipt</b> #0-20-114195 <a href="#">Print (PDF)</a>
<a href="#">2019 Annual Bill</a> ⓘ	\$0.00	<b>Paid</b> \$5,395.70 11/19/2019	<b>Receipt</b> #0-19-070500 <a href="#">Print (PDF)</a>
<a href="#">2018 Annual Bill</a> ⓘ	\$0.00	<b>Paid</b> \$5,171.44 11/09/2018	<b>Receipt</b> #0-18-056176 <a href="#">Print (PDF)</a>
<a href="#">2017 Annual Bill</a> ⓘ	\$0.00	<b>Paid</b> \$4,991.45 11/17/2017	<b>Receipt</b> #0-17-000252 <a href="#">Print (PDF)</a>
<a href="#">2016 Annual Bill</a> ⓘ	\$0.00	<b>Paid</b> \$4,476.80 11/08/2016	<b>Receipt</b> #0-16-000188 <a href="#">Print (PDF)</a>
<a href="#">2015 Annual Bill</a> ⓘ	\$0.00	<b>Paid</b> \$4,560.00 11/16/2015	<b>Receipt</b> #0-15-000248 <a href="#">Print (PDF)</a>
<a href="#">2014 Annual Bill</a> ⓘ	\$0.00	<b>Paid</b> \$4,491.02 11/12/2014	<b>Receipt</b> #0-14-000582 <a href="#">Print (PDF)</a>
<a href="#">2013 Annual Bill</a> ⓘ	\$0.00	<b>Paid</b> \$4,428.01 11/22/2013	<b>Receipt</b> #0-13-000972 <a href="#">Print (PDF)</a>
<a href="#">2012 Annual Bill</a> ⓘ	\$0.00	<b>Paid</b> \$4,344.94 11/16/2012	<b>Receipt</b> #0-12-000866 <a href="#">Print (PDF)</a>
<a href="#">2011 Annual Bill</a> ⓘ	\$0.00	<b>Paid</b> \$4,147.66 11/30/2011	<b>Receipt</b> #0-11-000262 <a href="#">Print (PDF)</a>
<a href="#">2010 Annual Bill</a> ⓘ	\$0.00	<b>Paid</b> \$4,520.05 11/30/2010	<b>Receipt</b> #0-10-000355 <a href="#">Print (PDF)</a>
<a href="#">2009 Annual Bill</a> ⓘ	\$0.00	<b>Paid</b> \$5,962.62 11/17/2009	<b>Receipt</b> #0-09-000078 <a href="#">Print (PDF)</a>
<a href="#">2008 Annual Bill</a> ⓘ	\$0.00	<b>Paid</b> \$7,093.18 11/14/2008	<b>Receipt</b> #0-08-000003 <a href="#">Print (PDF)</a>
<a href="#">2007 Annual Bill</a> ⓘ	\$0.00	<b>Paid</b> \$6,955.99 11/26/2007	<b>Receipt</b> #068-07-00004862 <a href="#">Print (PDF)</a>
<a href="#">2006</a> ⓘ			
<a href="#">2006 Installment Bill #4</a> ⓘ	\$0.00	<b>Paid</b> \$1,853.33 03/13/2007	<b>Receipt</b> #007-06-00022861 <a href="#">Print (PDF)</a>
<a href="#">2006 Installment Bill #3</a> ⓘ	\$0.00	<b>Paid</b> \$1,797.74 12/27/2006	<b>Receipt</b> #055-06-00157581 <a href="#">Print (PDF)</a>
<a href="#">2006 Installment Bill #2</a> ⓘ	\$0.00	<b>Paid</b> \$1,877.35 09/28/2006	<b>Receipt</b> #055-06-00014073 <a href="#">Print (PDF)</a>
<a href="#">2006 Installment Bill #1</a> ⓘ	\$0.00	<b>Paid</b> \$1,847.86 06/22/2006	<b>Receipt</b> #055-06-00005242 <a href="#">Print (PDF)</a>
		<b>Paid \$7,376.28</b>	
<a href="#">2005</a> ⓘ			
<a href="#">2005 Installment Bill #4</a> ⓘ	\$0.00	<b>Paid</b> \$2,104.05 03/31/2006	<b>Receipt</b> #055-05-00207236 <a href="#">Print (PDF)</a>
<a href="#">2005 Installment Bill #3</a> ⓘ	\$0.00	<b>Paid</b> \$2,040.93 12/21/2005	<b>Receipt</b> #055-05-00160728 <a href="#">Print (PDF)</a>
<a href="#">2005 Installment Bill #2</a> ⓘ	\$0.00	<b>Paid</b> \$1,745.33 09/30/2005	<b>Receipt</b> #055-05-00014062 <a href="#">Print (PDF)</a>
<a href="#">2005 Installment Bill #1</a> ⓘ	\$0.00	<b>Paid</b> \$1,717.92 06/20/2005	<b>Receipt</b> #055-05-00004135 <a href="#">Print (PDF)</a>
<b>Total Amount Due</b>	<b>\$0.00</b>		

BILL	AMOUNT DUE	STATUS	ACTION
<b>Paid \$7,608.23</b>			
<b>2004</b> ⓘ			
<a href="#">2004 Installment Bill #4</a> ⓘ	\$0.00	<b>Paid</b> \$2,155.55 03/30/2005	<b>Receipt</b> #055-04-00185656  <a href="#">Print (PDF)</a>
<a href="#">2004 Installment Bill #3</a> ⓘ	\$0.00	<b>Paid</b> \$2,090.89 12/29/2004	<b>Receipt</b> #012-04-00023269  <a href="#">Print (PDF)</a>
<a href="#">2004 Installment Bill #2</a> ⓘ	\$0.00	<b>Paid</b> \$1,432.10 09/14/2004	<b>Receipt</b> #055-04-00009571  <a href="#">Print (PDF)</a>
<a href="#">2004 Installment Bill #1</a> ⓘ	\$0.00	<b>Paid</b> \$1,409.61 06/15/2004	<b>Receipt</b> #055-04-00003358  <a href="#">Print (PDF)</a>
<b>Paid \$7,088.15</b>			
<b>2003</b> ⓘ			
<a href="#">2003 Installment Bill #4</a> ⓘ	\$0.00	<b>Paid</b> \$1,724.07 03/26/2004	<b>Receipt</b> #055-03-00188109  <a href="#">Print (PDF)</a>
<a href="#">2003 Installment Bill #3</a> ⓘ	\$0.00	<b>Paid</b> \$1,672.36 12/22/2003	<b>Receipt</b> #055-03-00145265  <a href="#">Print (PDF)</a>
<a href="#">2003 Installment Bill #2</a> ⓘ	\$0.00	<b>Paid</b> \$1,217.70 09/18/2003	<b>Receipt</b> #014-03-00000081  <a href="#">Print (PDF)</a>
<a href="#">2003 Installment Bill #1</a> ⓘ	\$0.00	<b>Paid</b> \$1,198.58 06/24/2003	<b>Receipt</b> #012-03-00003225  <a href="#">Print (PDF)</a>
<b>Paid \$5,812.71</b>			
<b>2002</b> ⓘ			
<a href="#">2002 Installment Bill #4</a> ⓘ	\$0.00	<b>Paid</b> \$1,610.42 03/28/2003	<b>Receipt</b> #055-02-00180542  <a href="#">Print (PDF)</a>
<a href="#">2002 Installment Bill #3</a> ⓘ	\$0.00	<b>Paid</b> \$1,562.12 12/19/2002	<b>Receipt</b> #015-02-00008913  <a href="#">Print (PDF)</a>
<a href="#">2002 Installment Bill #2</a> ⓘ	\$0.00	<b>Paid</b> \$897.45 09/30/2002	<b>Receipt</b> #013-02-00004055  <a href="#">Print (PDF)</a>
<a href="#">2002 Installment Bill #1</a> ⓘ	\$0.00	<b>Paid</b> \$883.36 06/20/2002	<b>Receipt</b> #013-02-00001593  <a href="#">Print (PDF)</a>
<b>Paid \$4,953.35</b>			
<b>2001</b> ⓘ			
<a href="#">2001 Installment Bill #4</a> ⓘ	\$0.00	<b>Paid</b> \$1,053.95 03/29/2002	<b>Receipt</b> #055-01-00201534  <a href="#">Print (PDF)</a>
<a href="#">2001 Installment Bill #3</a> ⓘ	\$0.00	<b>Paid</b> \$1,022.33 12/17/2001	<b>Receipt</b> #004-01-00021201  <a href="#">Print (PDF)</a>
<a href="#">2001 Installment Bill #2</a> ⓘ	\$0.00	<b>Paid</b> \$788.37 09/19/2001	<b>Receipt</b> #010-01-00001512  <a href="#">Print (PDF)</a>
<a href="#">2001 Installment Bill #1</a> ⓘ	\$0.00	<b>Paid</b> \$775.99 06/13/2001	<b>Receipt</b> #007-01-00001650  <a href="#">Print (PDF)</a>
<b>Paid \$3,640.64</b>			
<b>2000</b> ⓘ			
<a href="#">2000 Installment Bill #4</a> ⓘ	\$0.00	<b>Paid</b> \$931.44 03/22/2001	<b>Receipt</b> #002-00-00038346  <a href="#">Print (PDF)</a>
<a href="#">2000 Installment Bill #3</a> ⓘ	\$0.00	<b>Paid</b> \$903.50 12/29/2000	<b>Receipt</b> #055-00-00165874  <a href="#">Print (PDF)</a>
<a href="#">2000 Installment Bill #2</a> ⓘ	\$0.00	<b>Paid</b> \$687.21 09/19/2000	<b>Receipt</b> #007-00-00010623  <a href="#">Print (PDF)</a>
<a href="#">2000 Installment Bill #1</a> ⓘ	\$0.00	<b>Paid</b> \$676.41 06/30/2000	<b>Receipt</b> #007-00-00005003  <a href="#">Print (PDF)</a>
<b>Paid \$3,198.56</b>			
<b>1999</b> ⓘ			
<a href="#">1999 Installment Bill #4</a> ⓘ	\$0.00	<b>Paid</b> \$698.62 03/24/2000	<b>Receipt</b> #007-99-00038680  <a href="#">Print (PDF)</a>
<a href="#">1999 Installment Bill #3</a> ⓘ	\$0.00	<b>Paid</b> \$677.67 12/30/1999	<b>Receipt</b> #002-99-00031045  <a href="#">Print (PDF)</a>
<a href="#">1999 Installment Bill #2</a> ⓘ	\$0.00	<b>Paid</b> \$707.23 09/30/1999	<b>Receipt</b> #007-99-00005963  <a href="#">Print (PDF)</a>
<a href="#">1999 Installment Bill #1</a> ⓘ	\$0.00	<b>Paid</b> \$696.12 06/24/1999	<b>Receipt</b> #002-99-00006161  <a href="#">Print (PDF)</a>
<b>Paid \$2,779.64</b>			
<b>Total Amount Due</b>	<b>\$0.00</b>		



## COURTESY NOTICE OF CODE VIOLATION

SEPTEMBER 13, 2022

VESTGAARDEN, TOV I  
590 NORMANDY RD  
MADEIRA BEACH FL 33708- 2343

Case Number: 2022.3526

Parcel #: 10-31-15-43272-000-0430

Legal Description: ISLAND ESTATES UNIT NO. 1 N 1/2 LOT 43 & S 49 FT OF LOT 42

Address: 590 NORMANDY RD

During a recent review of properties, it was noted that your property is in violation of the following code/ordinance(s):

Ordinance(s):

**Sec. 86-52. - When required.**

A person, firm or corporation shall not construct, enlarge, alter, repair, move, demolish, or change the occupancy of a building or structure, or erect, or construct a sign, or install or alter fire extinguishing apparatus, elevators, engines, steam boiler, furnace, incinerator, or other heat producing apparatus, plumbing, mechanical or electrical equipment or any appurtenances, the installation of which is regulated by the land development regulations or other sections of the Code until a permit has been issued by the building official. When the cost of repair or modification does not exceed \$500.00, does not result in a structural change, and does not require an inspection, a permit need not be issued by the building official. No permit is required for uncovered flat slabs of no greater than 50 square feet, for work of a strictly cosmetic nature (painting, wallpapering, carpeting, kitchen cabinets, etc.) or roof work less than \$100.00 in value.

Therefore, if the action(s) specified in this notice is not completed by 8:00 am of the re-inspection date listed, the City will take legal action concerning this violation(s). This action may include the issuance of a citation and imposition of a fine of up to five hundred dollars (\$500) per day. The City may also take the required action itself and lien the above property for all costs associated therewith, including an administrative fee of one hundred dollars (\$100).



**Violation Detail:**

- Work being done at the property without the required building permit(s).

**Corrective action:**

Either the property owner and/or licensed contractor will need to apply for and obtain an “after-the-fact” building permit to comply.

Please reply with a plan of corrections before the follow-up date listed:

Follow-up date:

SEPTEMBER 23, 2022

Laura Roby, CPMHI

City of Madeira Beach – Building Department

[lroby@madeirabeachfl.gov](mailto:lroby@madeirabeachfl.gov)

727.391.9951 ext. 298

Therefore, if the action(s) specified in this notice is not completed by 8:00 am of the re-inspection date listed, the City will take legal action concerning this violation(s). This action may include the issuance of a citation and imposition of a fine of up to five hundred dollars (\$500) per day. The City may also take the required action itself and lien the above property for all costs associated therewith, including an administrative fee of one hundred dollars (\$100).



## NOTICE OF CODE VIOLATION

FEBRUARY 08, 2023

VESTGAARDEN, TOV I  
590 NORMANDY RD  
MADEIRA BEACH FL 33708- 2343

Case Number: 2022.3526

Parcel #: 10-31-15-43272-000-0430

Legal Description: ISLAND ESTATES UNIT NO. 1 N 1/2 LOT 43 & S 49 FT OF LOT 42

Address: 590 NORMANDY RD

During a recent review of properties, it was noted that your property is in violation of the following code/ordinance(s):

Ordinance(s):

**Sec. 86-52. - When required.**

A person, firm or corporation shall not construct, enlarge, alter, repair, move, demolish, or change the occupancy of a building or structure, or erect, or construct a sign, or install or alter fire extinguishing apparatus, elevators, engines, steam boiler, furnace, incinerator, or other heat producing apparatus, plumbing, mechanical or electrical equipment or any appurtenances, the installation of which is regulated by the land development regulations or other sections of the Code until a permit has been issued by the building official. When the cost of repair or modification does not exceed \$500.00, does not result in a structural change, and does not require an inspection, a permit need not be issued by the building official. No permit is required for uncovered flat slabs of no greater than 50 square feet, for work of a strictly cosmetic nature (painting, wallpapering, carpeting, kitchen cabinets, etc.) or roof work less than \$100.00 in value.

Therefore, if the action(s) specified in this notice is not completed by 8:00 am of the re-inspection date listed, the City will take legal action concerning this violation(s). This action may include the issuance of a citation and imposition of a fine of up to five hundred dollars (\$500) per day. The City may also take the required action itself and lien the above property for all costs associated therewith, including an administrative fee of one hundred dollars (\$100).



**Violation Detail:**

- Work being done at the property without the required building permit(s).

**Corrective action:**

Either the property owner and/or licensed contractor will need to apply for and obtain an “after-the-fact” building permit to comply.

Please reply with a plan of corrections before the follow-up date listed:

Follow-up date:

FEBRUARY 22, 2022

Laura Roby, CPMHI

City of Madeira Beach – Building Department

[lroby@madeirabeachfl.gov](mailto:lroby@madeirabeachfl.gov)

727.391.9951 ext. 298

Certified Mail # 7019 2970 0000 5514 1391

Therefore, if the action(s) specified in this notice is not completed by 8:00 am of the re-inspection date listed, the City will take legal action concerning this violation(s). This action may include the issuance of a citation and imposition of a fine of up to five hundred dollars (\$500) per day. The City may also take the required action itself and lien the above property for all costs associated therewith, including an administrative fee of one hundred dollars (\$100).

**SENDER: COMPLETE THIS SECTION**

- Complete items 1, 2, and 3.
- Print your name and address on the reverse so that we can return the card to you.
- Attach this card to the back of the mailpiece, or on the front if space permits.

1. Article Addressed to:

VESTGARDEN, TOV  
 590 NORMANDY RD.  
 MADEIRA BEACH, FL 33708



9500 9402 6918 1028 7502 08

2. Article Number (Transfer from service label)

16ET 4T55 0000 0L62 6T0L

FS Form 3821, July 2020 ©2020 USPS® (over \$500)

**COMPLETE THIS SECTION ON DELIVERY**

A. Signature

X

- Agent
- Addressee

B. Received by (Printed Name)

C. Date of Delivery

D. Is delivery address different from item 1?  Yes  No  
 If YES, enter delivery address below:

3. Service Type
- Adult Signature
  - Adult Signature Restricted Delivery
  - Certified Mail®
  - Certified Mail Restricted Delivery
  - Collect on Delivery
  - Collect on Delivery Restricted Delivery
  - Insured Mail
  - Insured Mail Restricted Delivery (over \$500)
  - Priority Mail Express®
  - Registered Mail™
  - Registered Mail Restricted Delivery
  - Signature Confirmation™
  - Signature Confirmation Restricted Delivery

Domestic Return Receipt



quodient  
 FIRST-CLASS MAIL  
 IM1  
**\$008.10** 9  
 02/07/2023 ZIP 33708  
 049M31233717

**US POSTAGE**



7019 2970 0000 5514 1391



Municipal Drive  
 Madeira Beach, Florida 33708

FEBRUARY 08, 2023

VESTGARDEN, TOV I

590 NORMANDY RD

MADEIRA BEACH FL 33708-2343

**SENDER: COMPLETE THIS SECTION**

- Complete items 1, 2, and 3.
- Print your name and address on the reverse so that we can return the card to you.
- Attach this card to the back of the mailpiece, or on the front if space permits.

1. Article Addressed to:

VESTBARDEN, TOV  
 590 NORMANDY RD.  
 MADEIRA BEACH, FL 33708



9590 9402 6618 1028 7502 08

2 Article Number (Transfer from service label)

7019 2970 0000 5514 1391

**COMPLETE THIS SECTION ON DELIVERY**

A. Signature

X

- Agent
- Addressee

B. Received by (Printed Name)

C. Date of Delivery

2-11

D. Is delivery address different from item 1?  Yes  
If YES, enter delivery address below:  No

3. Service Type

- Adult Signature
- Adult Signature Restricted Delivery
- Certified Mail®
- Certified Mail Restricted Delivery
- Collect on Delivery
- Collect on Delivery Restricted Delivery
- Insured Mail
- Insured Mail Restricted Delivery (over \$500)
- Priority Mail Express®
- Registered Mail™
- Registered Mail Restricted Delivery
- Signature Confirmation™
- Signature Confirmation Restricted Delivery

PS Form 3811, July 2020 PSN 7530-02-000-9053

Domestic Return Receipt

USPS TRACKING#



TAMPA, FL 335

11 FEB 2023 PM 4 L

First-Class Mail  
 Postage & Fees Paid  
 USPS  
 Permit No. G-10

9590 9402 6618 1028 7502 08

United States  
Postal Service

• Sender: Please print your name, address, and ZIP+4® in this box•

City of Madeira Beach  
 Building Department  
 300 Municipal Dr.  
 Madeira Beach, FL 33708

BUILDING

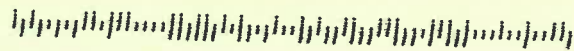



**CODE ENFORCEMENT SPECIAL MAGISTRATE  
CITY OF MADEIRA BEACH**

February 16, 2024  
City of Madeira Beach  
300 Municipal Drive  
Madeira Beach, Florida 33708

Petitioner,

vs.

CASE NO. 2022.3526

VESTGAARDEN, TOV I  
590 NORMANDY RD  
MADEIRA BEACH FL 33708

Respondents.

**RE Property:** 590 NORMANDY RD      **Parcel # 10-31-15-43272-000-0430**

**Legal Description:** ISLAND ESTATES UNIT NO. 1 N ½ LOT 43 & S 49 FT OF LOT 42

---

**STATEMENT OF VIOLATION/ REQUEST FOR HEARING**

To whom it may concern:

During a recent review of properties on your street, it was noted that your property is in violation of the following code section(s):

Sec. 86-52. – When required.

A person, firm or corporation shall not construct, enlarge, alter, repair, move, demolish, or change the occupancy of a building or structure, or erect, or construct a sign, or install or alter fire extinguishing apparatus, elevators, engines, steam boiler, furnace, incinerator, or other heat producing apparatus, plumbing, mechanical or electrical equipment or any appurtenances, the installation of which is regulated by the land development regulations or other sections of the Code until a permit has been issued by the building official. When the cost of repair or modification does not exceed \$500.00, does not result in a structural change, and does not require an inspection, a permit need not be issued by the building official. No permit is required for uncovering flat slabs of no greater than 50 square feet, for work of strictly cosmetic nature (painting, wallpapering, carpeting, kitchen cabinets, etc.) or roof work less than \$100.00 in value.

Please bring the property into compliance by applying for and obtaining an “after-the-fact” building permit or removing unpermitted work within seven (7) days of the date of this letter. Should you fail to bring the property into compliance within seven (7) days the City will bring this case to the Special Magistrate. Please note that the Special Magistrate can levy fines up to \$250.00 per day for each day the property remains in non-compliance.

I DO HEREBY SWEAR THAT THE ABOVE FACTS ARE TRUE TO THE BEST OF MY KNOWLEDGE. I REQUEST A HEARING ON THE ABOVE VIOLATION(S) BY THE SPECIAL MAGISTRATE OF THE CITY OF MADEIRA BEACH.



---

**Grace Mills, Code Compliance Officer  
City of Madeira Beach**

**CODE ENFORCEMENT SPECIAL MAGISTRATE  
CITY OF MADEIRA BEACH**

February 20, 2024  
City of Madeira Beach  
300 Municipal Drive  
Madeira Beach, Florida 33708

Petitioner,

vs.

CASE NO. 2022.3526

VESTGAARDEN, TOV I  
590 NORMANDY RD  
MADEIRA BEACH FL 33708-2343

Respondents.

**RE Property:** 590 Normandy Rd.

**Parcel # 10-31-15-43272-000-0430**

**Legal Description: ISLAND ESTATES UNIT NO. 1 N ½ LOT 43 & S 49 FT OF LOT 42**

---

**AMENDED AFFIDAVIT OF SERVICE**

I, Grace Mills, Building Code Compliance Officer II of the City of Madeira Beach, upon being duly sworn, deposed and says the following:

That pursuant to Florida Statute 162.12,

On the 16<sup>th</sup> day of February, 2024, I mailed a copy of the attached NOTICE OF HEARING via Certified Mail, Return Receipt Requested.

On the 16<sup>th</sup> day of February, 2024, I mailed a copy of the attached NOTICE OF HEARING via First Class mail.

On the 16<sup>th</sup> day of February, 2024, I posted a copy of the attached NOTICE OF HEARING on the property located at 590 Normandy Rd, Parcel # 10-31-15-43272-000-0430 the City of Madeira Beach.

On the 16<sup>th</sup> day of February, 2024, I caused the attached NOTICE OF HEARING to be posted at the Municipal Government Offices, 300 Municipal Drive, Madeira Beach; and that said papers remain posted at the Municipal Government Offices for a period of not less than ten days from the date of posting.

*Grace Mills*

Grace Mills, Code Compliance Officer  
City of Madeira Beach

STATE OF FLORIDA

COUNTY OF PINELLAS

The foregoing instrument was acknowledged before me, the undersigned authority, by means of  physical presence or  online notarization, this 20<sup>TH</sup> day of FEBRUARY, 2024, by Grace Mills, who is personally known to me, or produced \_\_\_\_\_ as identification. My Commission Expires: 06/26/25

Notary Public- State of Florida

*[Signature]*

Print or type Name.

HOLDEN PINICARD

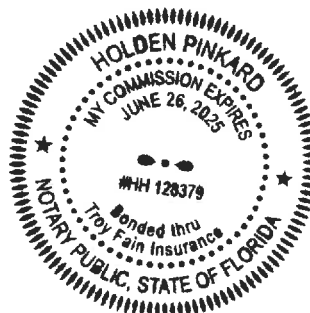

**CODE ENFORCEMENT SPECIAL MAGISTRATE  
CITY OF MADEIRA BEACH**

February 16, 2024  
City of Madeira Beach  
300 Municipal Drive  
Madeira Beach, Florida 33708

Petitioner,

CASE NO. 2022.3526

vs.  
VESTGAARDEN, TOV I  
590 NORMANDY RD  
MADEIRA BEACH FL 33708-2343

Respondents.

**RE Property:** 590 Normandy Rd    **Parcel #10-31-15-43272-000-0430**

**Legal Description:** ISLAND ESTATES UNIT NO. 1 N ½ LOT 43 & S 49 FT OF LOT 42

---

**NOTICE OF HEARING**

To whom it may concern:

YOU ARE HEREBY FORMALLY NOTIFIED that at **02:00 pm** on **MONDAY** the **26<sup>th</sup>** day of February, **2024** at the Madeira Beach City Center in the Patricia Shontz Commission Chambers, located at 300 Municipal Drive, Madeira Beach, Florida 33708, a hearing will be held before the Special Magistrate concerning the following code violation(s):

**Sec. 86-52. – When required.**

A person, firm or corporation shall not construct, enlarge, alter, repair, move, demolish, or change the occupancy of a building or structure, or erect, or construct a sign, or install or alter fire extinguishing apparatus, elevators, engines, steam boiler, furnace, incinerator, or other heat producing apparatus, plumbing, mechanical or electrical equipment or any appurtenances, the installation of which is regulated by the land development regulations or other sections of the Code until a permit has been issued by the building official. When the cost of repair or modification does not exceed \$500.00, does not result in a structural change, and does not require an inspection, a permit need not be issued by the building official. No permit is required for uncovering flat slabs of no greater than 50 square feet, for work of strictly cosmetic nature (painting, wallpapering, carpeting, kitchen cabinets, etc.) or roof work less than \$100.00 in value.

You are hereby ordered to appear before the Special Magistrate of the City of Madeira Beach on that date and time to answer these charges and to present your side of the case. Failure to appear may result in the Special Magistrate proceeding in your absence.

Should you be found in violation of the above code, the Special Magistrate has the power by law to levy fines of up to \$250.00 per day for an initial violation(s) and \$500.00 per day for repeat violations against you and your property for every day that any violation continues beyond the date set in an order of the Special Magistrate for compliance.

If the violation is corrected and then recurs, or if the violation is not corrected by the time specified by the Code Enforcement Officer for correction, the case may still be presented to the Special Magistrate of the City of Madeira Beach even if the violation has been corrected prior to the Special Magistrate hearing.

Should you desire, you have the right to obtain an attorney at your own expense to represent you before the Special Magistrate. You will also have the opportunity to present witnesses as well as question the witnesses against you prior to the Special Magistrate making a determination.

Please be prepared to present evidence at this meeting concerning the time frame necessary to correct the alleged violation(s), should you be found in violation of the City Code.

If you wish to have any witnesses subpoenaed or have any other questions, please contact the Code Enforcement department of the City of Maderia Beach within five (5) days at 300 Municipal Drive, Maderia Beach, Florida 33708, telephone number (727) 391-9951 ext 298.

Your failure to respond to the previously issued Notice of Violation has resulted in costs of prosecution of this case.

PLEASE NOTE: Should any interested party seek to appeal any decision made by the Special Magistrate with respect to any matter considered at such meeting or hearing, he/she will need a record of the proceedings, and for such purpose, he/she may need to ensure that a verbatim record of the proceedings is made which record includes the testimony and evidence upon which the appeal is to be based per Florida Statute 286.0105.

I DO HEREBY CERTIFY that a copy of the foregoing Notice of Hearing was mailed to Respondent(s) by certified mail, return receipt requested.

Dated this 16 day of February, 2024.

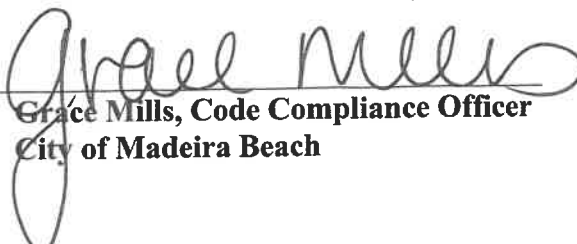
  
Grace Mills, Code Compliance Officer  
City of Madeira Beach

CERTIFIED MAIL



7021 2720 0003 1476 8583

Municipal Drive  
Madeira Beach, Florida 33708

Petitioner,

vs.  
VESTGAARDEN, TOV I  
590 NORMANDY RD  
MADEIRA BEACH FL 33708-2343

**SENDER: COMPLETE THIS SECTION**

- Complete items 1, 2, and 3.
- Print your name and address on the reverse so that we can return the card to you.
- Attach this card to the back of the mailpiece, or on the front if space permits.

1. Article Addressed to:

Vestgaarden, Tov 1  
590 Normandy Rd  
Madeira Beach FL 33708



9590 9402 7951 2305 9233 21

2. Article Number (Transfer from service label)

7021 2720 0003 1476 8583

**COMPLETE THIS SECTION ON DELIVERY**

A. Signature

X

- Agent
- Addressee

B. Received by (Printed Name)

C. Date of Delivery

D. Is delivery address different from item 1?  Yes  
If YES, enter delivery address below:  No

3. Service Type

- Adult Signature
- Adult Signature Restricted Delivery
- Certified Mail®
- Certified Mail Restricted Delivery
- Collect on Delivery
- Collect on Delivery Restricted Delivery
- Insured Mail
- Insured Mail Restricted Delivery (over \$500)
- Priority Mail Express®
- Registered Mail™
- Registered Mail Restricted Delivery
- Signature Confirmation™
- Signature Confirmation Restricted Delivery

PS Form 3811, July 2020 PSN 7530-02-000-9053

Domestic Return Receipt





Feb 16, 2024 10:16:32 AM  
589 Normandy Road  
Madeira Beach  
Pinellas County  
Florida

Feb 2, 2024 at 1:25:17 PM

