

An aerial photograph of John's Pass Village, Florida, showing a mix of residential buildings, a marina with numerous boats, and a waterfront promenade. The image is overlaid with a white rectangular border and large white text.

John's Pass Village Activity Center Zoning Workshop

WHY

- Protect the Village
- Compatible redevelopment
- Consistency with the Countywide Plan
- Proactive instead of Reactive Planning

Legend

— John's Pass Village Activity Center Study Area

0.1 0.05 0 0.1 Miles



Relationship with Local Land Regulations

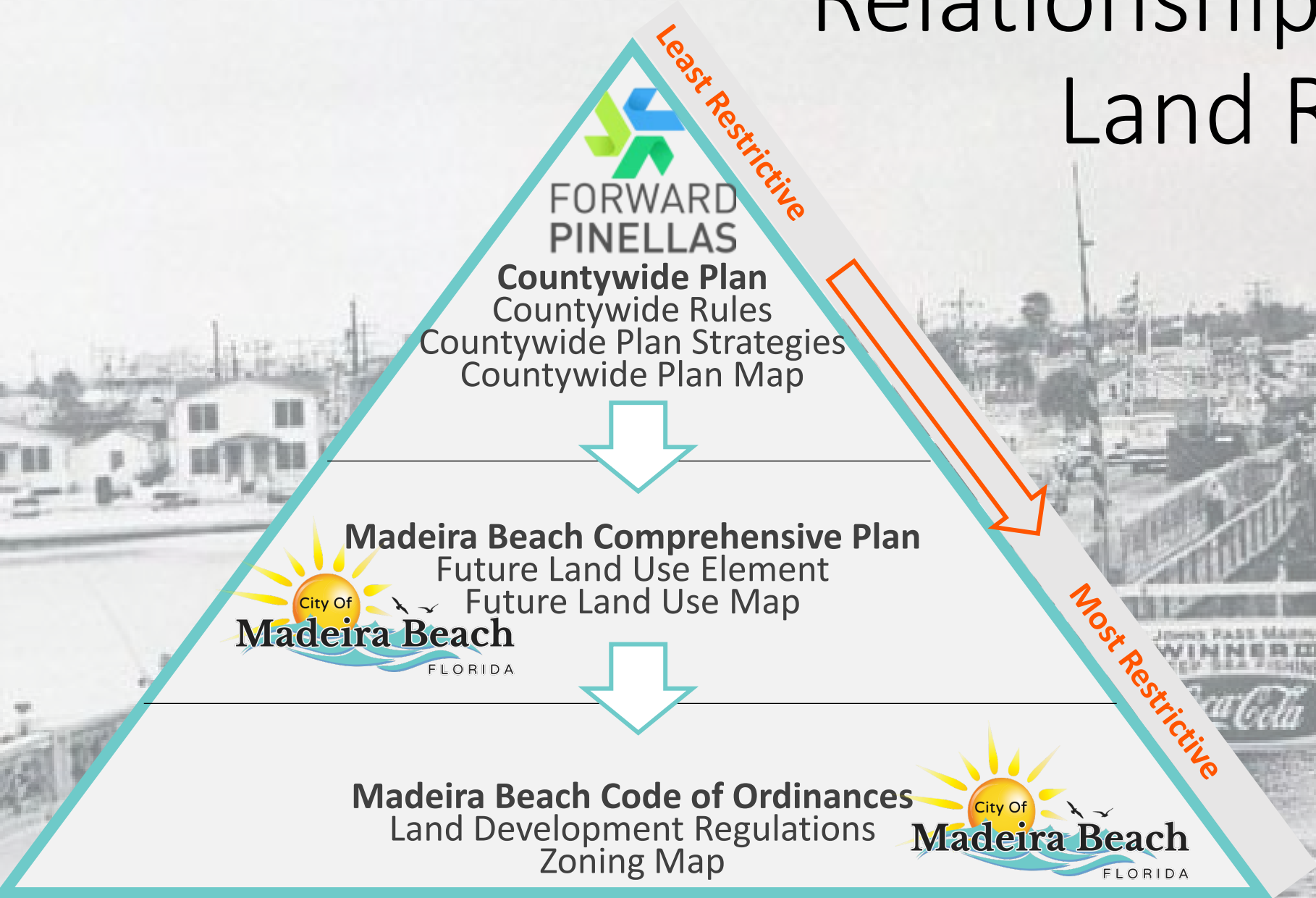

COUNTYWIDE PLAN MAP

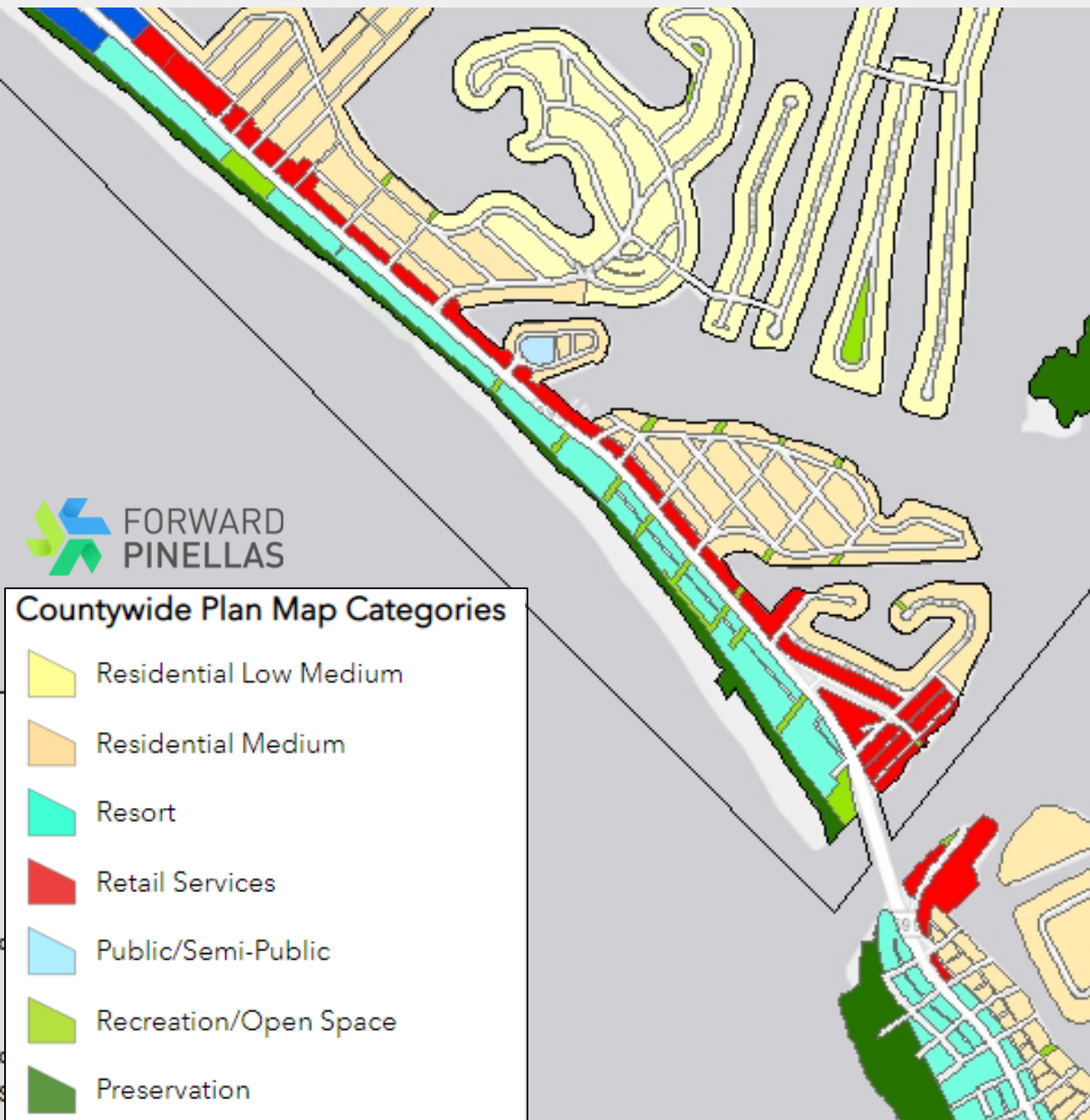

MADEIRA BEACH ZONING MAP

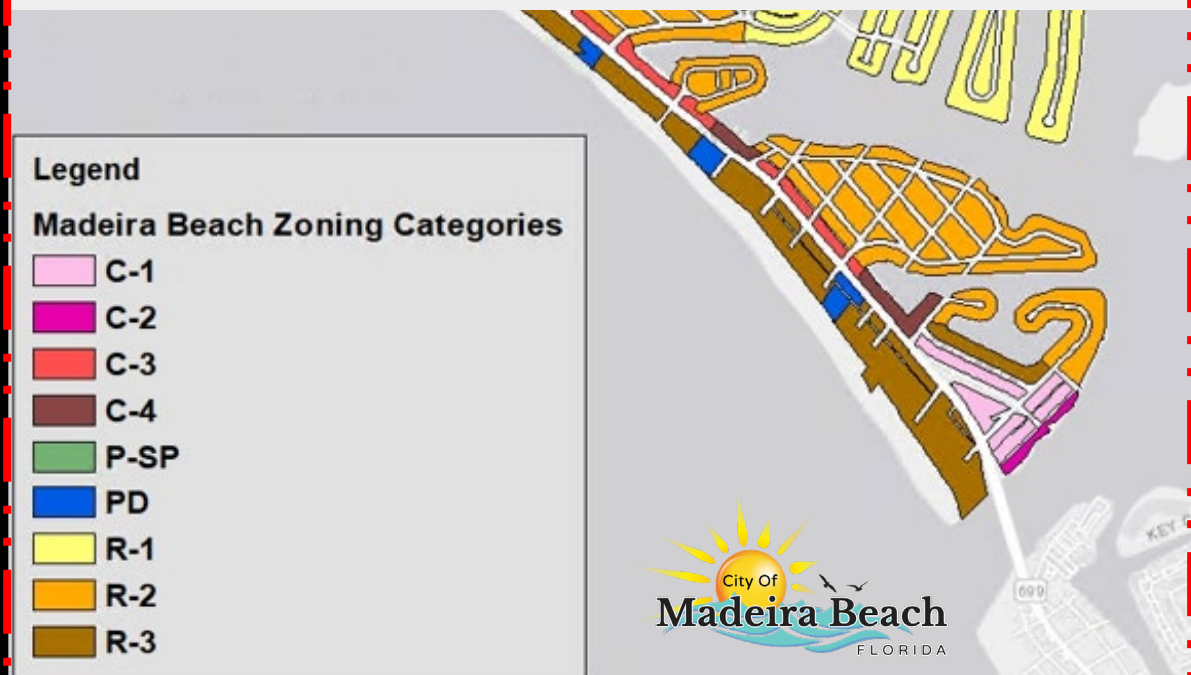

MADEIRA BEACH FUTURE LAND USE MAP

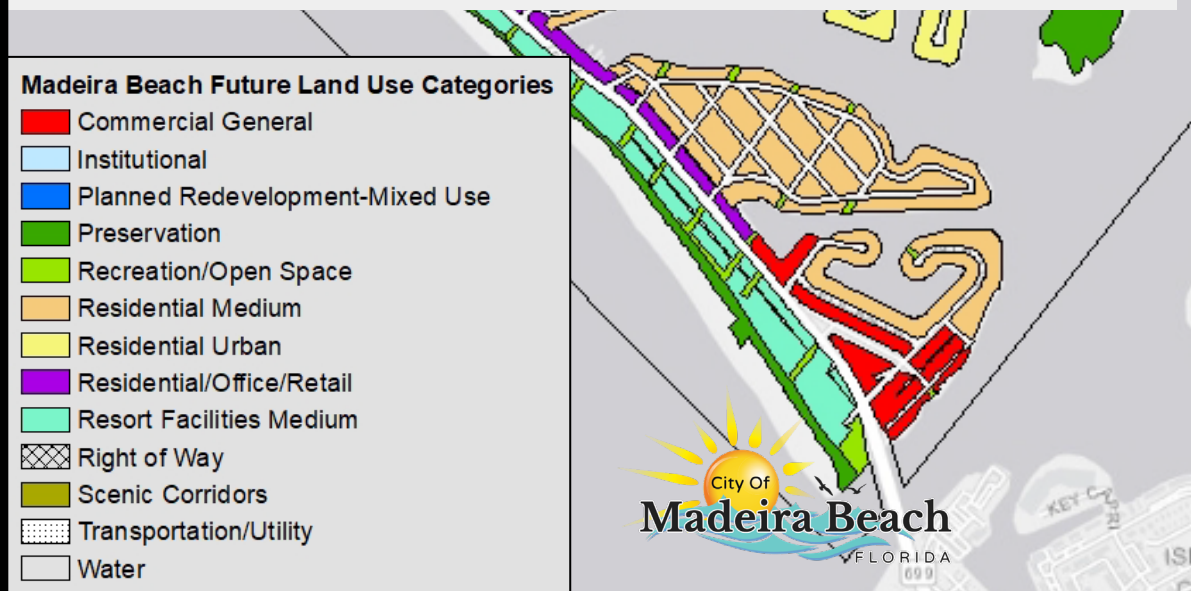

EXISTING DENSITIES AND INTENSITIES

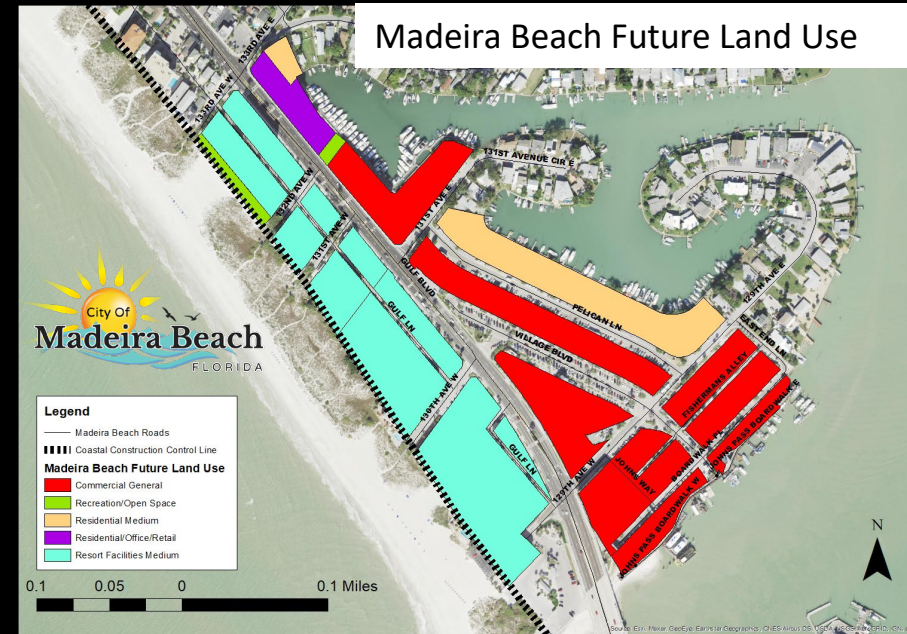
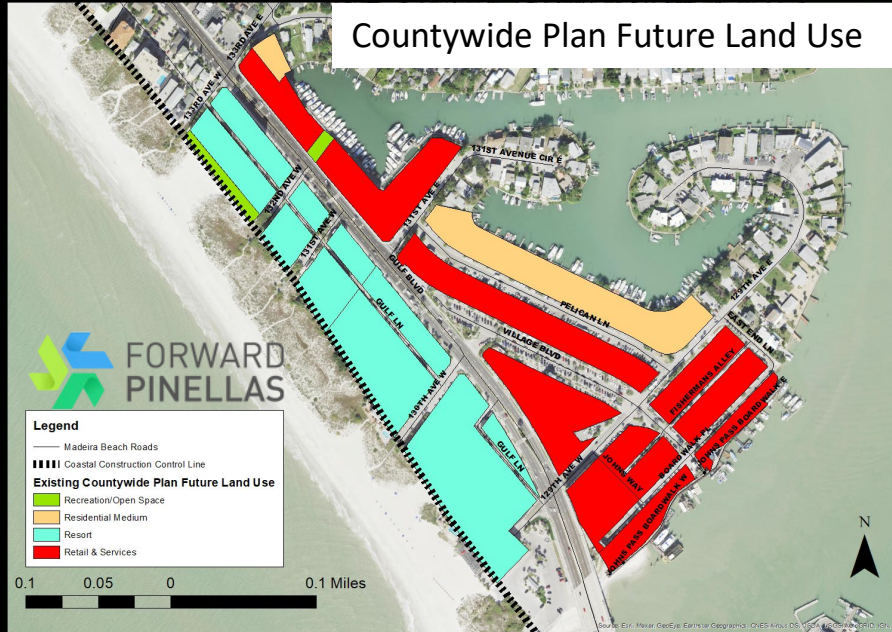

Countywide Plan Future Land Use			Madeira Beach Comprehensive Plan Future Land Use		
Retail and Services	FAR 0.55	RES UPA: 24 TEMP UPA: 40	Commercial General	FAR 1.2	RES UPA: 15 TEMP UPA: 60
Resort	FAR 1.2	RES UPA: 30 TEMP UPA: 50	Residential/Office/Retail	FAR 1.0	RES UPA: 18 TEMP UPA: 45
Residential Medium	FAR 0.5	RES UPA: 15 TEMP UPA: 0	Resort Facilities Medium	FAR 1.0 – 2.0 (Depends on Lot Area)	RES UPA: 18 TEMP UPA: 45-75
Recreation/Open Space	FAR 0.25	RES UPA: 0 TEMP UPA: 0	Residential Medium	Not specified in Comp Plan. In Zoning	RES UPA: 15 TEMP UPA: 0
			Recreation/Open Space	FAR 0.25	RES UPA: 0 TEMP UPA: 0

John's Pass Village Activity Center



Proposed Activity Center Plan: Character Districts

Traditional Village

Commercial Core

Boardwalk

John's Pass Resort

Low Intensity Mixed Use

Transitional



Countywide Plan Map

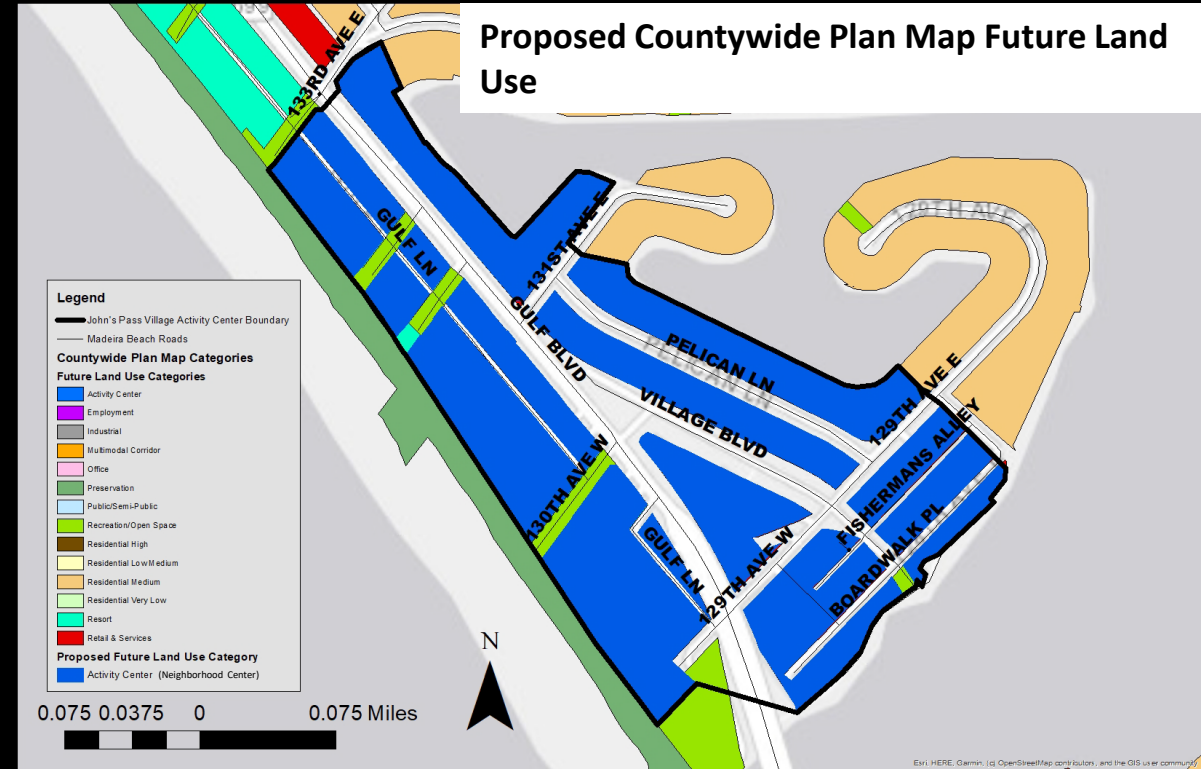
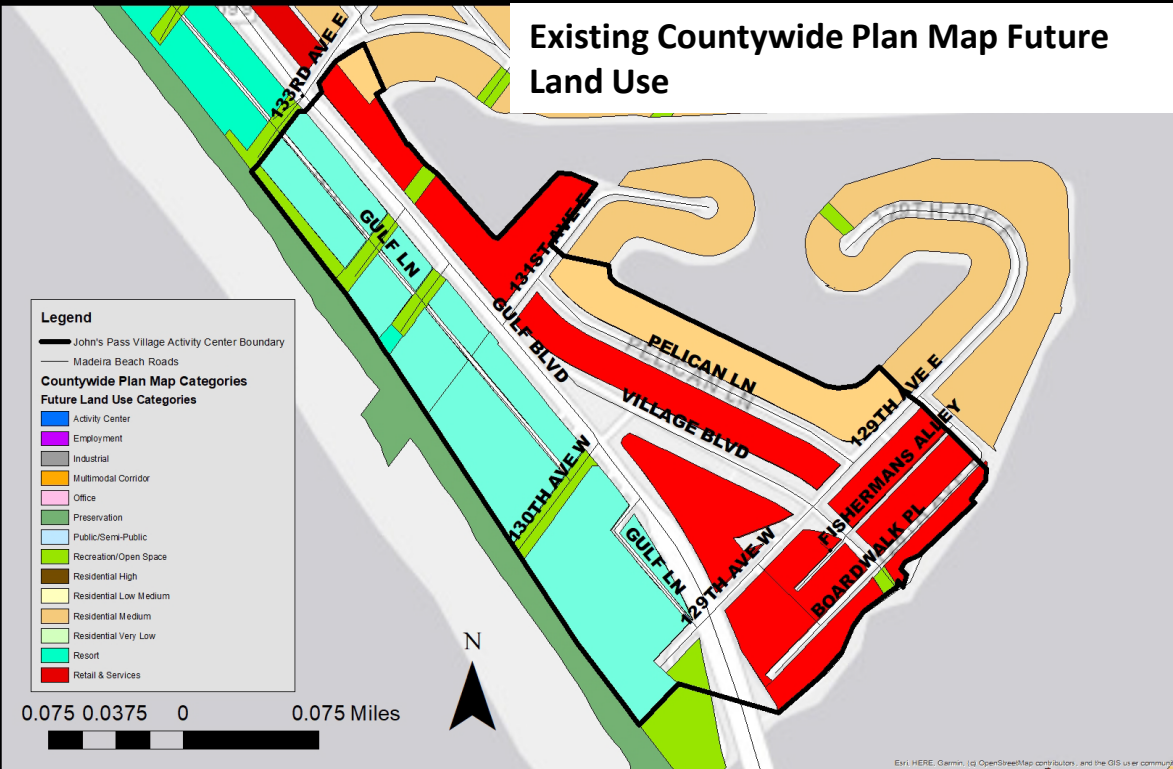

Madeira Beach Future Land Use Map

Existing Madeira Beach Future Land Use Map

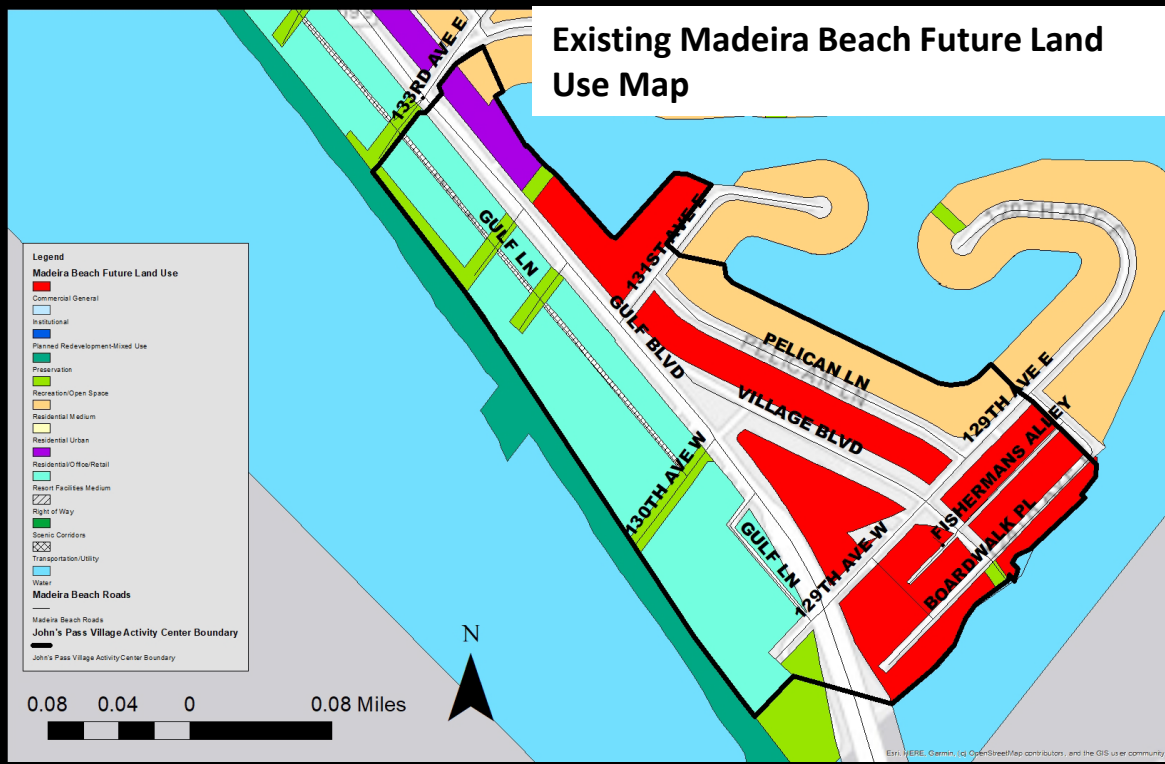

Proposed Madeira Beach Future Land Use Map



Madeira Beach Zoning Map

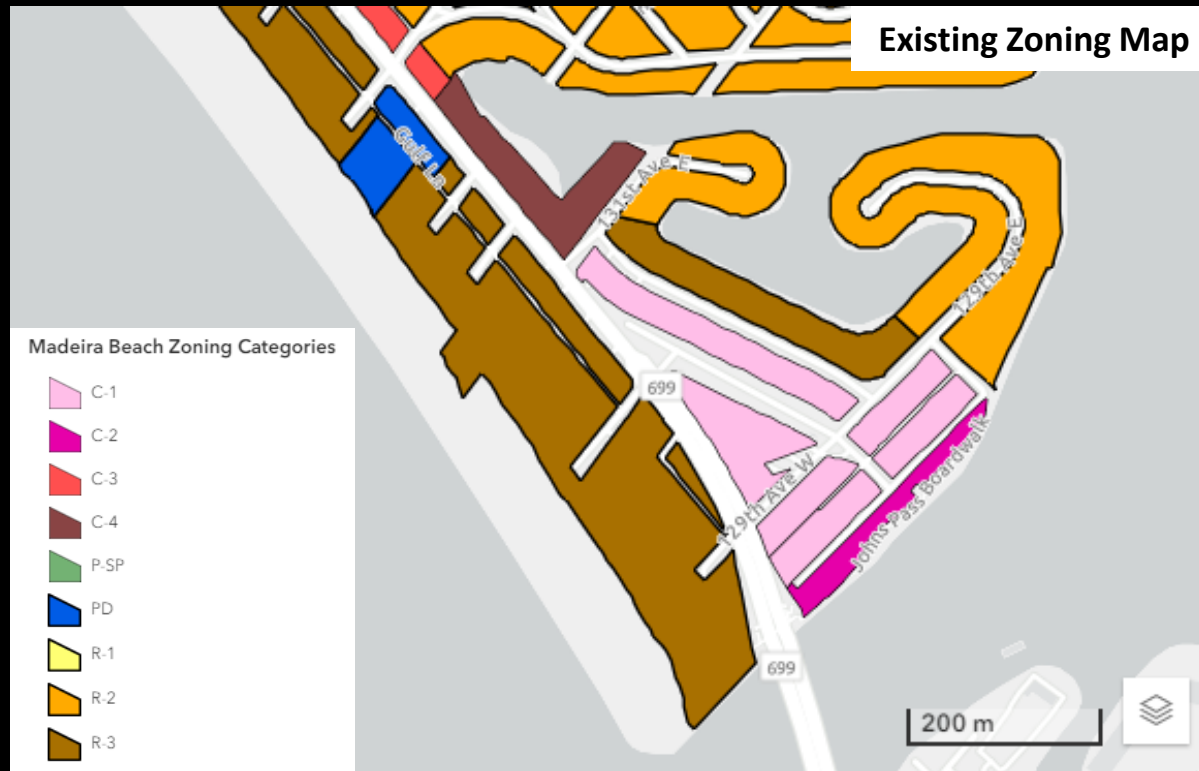

FAR: 1.5/2.0*
Temp UPA: 50/75*
Res UPA: 18

FAR: 1.5/2.0*
Temp UPA: 40/60*
Res UPA: 18

FAR: 2.0
Temp UPA: 45
Res UPA: 15

FAR: 2.0/2.2-3.0*
Temp UPA: 60/75-100*
Res UPA: 15

FAR: 2.0/2.2-2.5*
Temp UPA: 60/75-100*
Res UPA: 18

FAR: 1.5
Temp UPA: 0
Res UPA: 0

Legend

- Madeira Beach Roads
- ▬▬▬▬ Coastal Construction Control Line

John's Pass Village Activity Center Character Districts

- Boardwalk
- Commercial Core
- John's Pass Resort
- Low Intensity Mixed Use
- Tradional Village
- Transitional

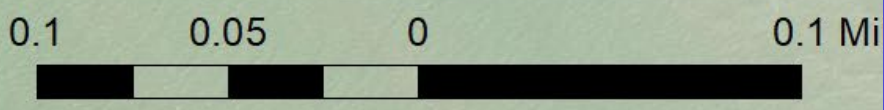

Madeira Beach Code of Ordinances

Zoning Districts

- Setbacks
- Height
- Impervious Surface Ratio
- Special Requirements
 - Design Standards
 - not allowed for single-family and duplex
 - Architectural features
 - Buffering Requirements
 - Use and Zone-specific landscaping

Land Development Regulations

- Landscaping
- Sidewalks and Driveways
- Accessory Structures
- Parking Standards
- Swimming Pools

Madeira Beach Land Development Regulations

C-1 Zoning

Setbacks: Front Yard (none), Side Yard (10 ft one side), Rear Yard (25 ft)

Height: 34 ft

Floor Area Ratio: 0.55 for commercial uses

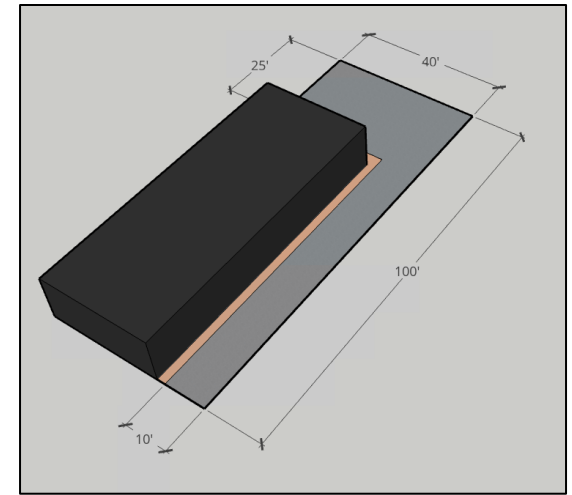
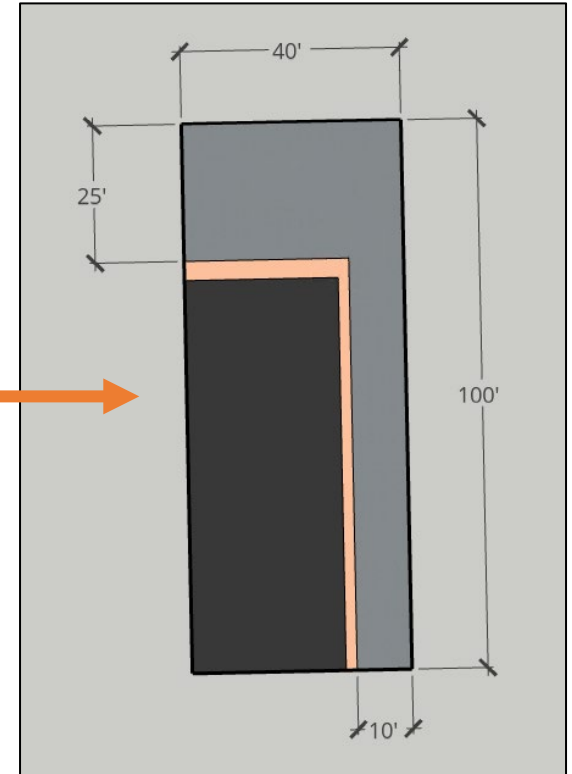
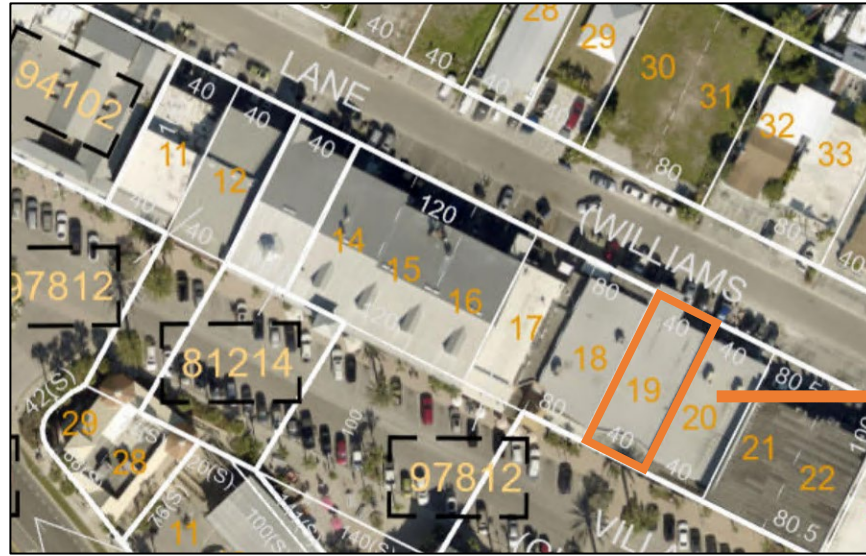

Madeira Beach Land Development Regulations

R-3 Zoning

Setbacks: Front Yard (20-25ft*), Side Yard (5-10 ft*), Rear Yard (CCCL or 25 ft*)

Height: 44 ft

Floor Area Ratio: 0.55
commercial use

*based on use and width of lot

**images based only on setbacks and height (not including landscape requirements and ISR)

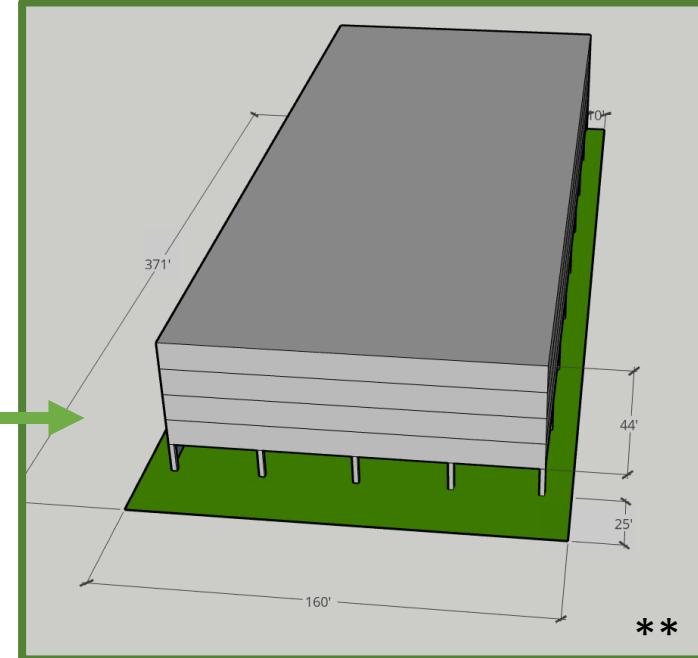
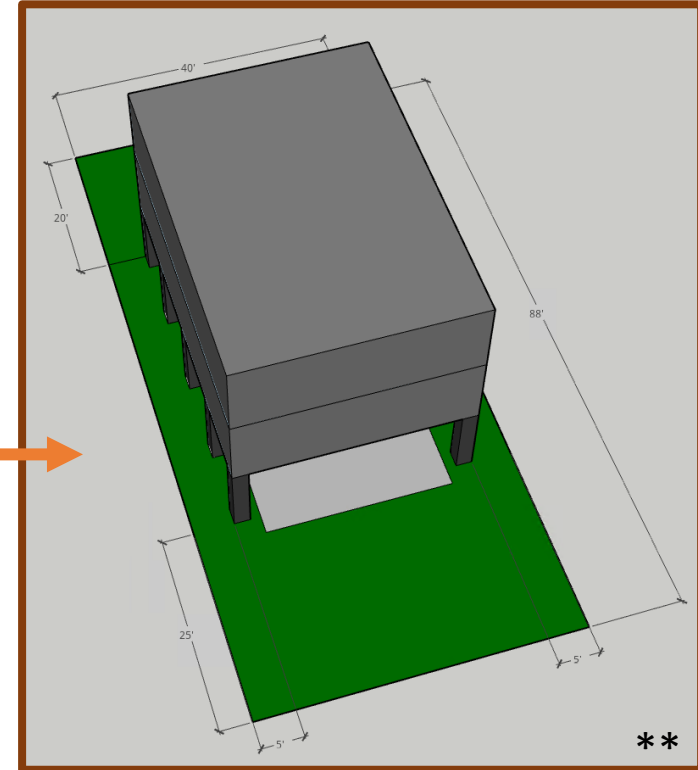
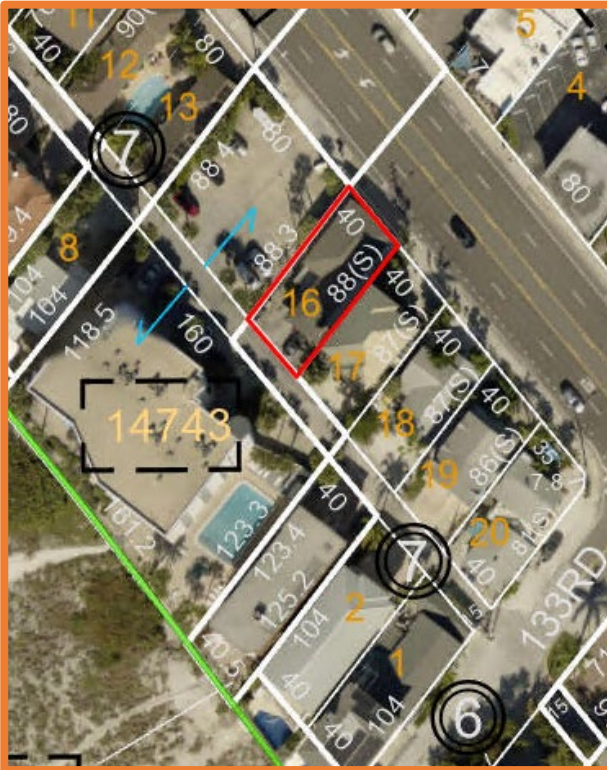

Planning and Urban Design Principles

The Activity Center Plan includes Design Policies and Principles based on:

- The City Comprehensive Plan which supports the special character and unique design features of John's Pass Village
- The Countywide Strategies Plan that requires certain design principles be addressed, including:
 - Location, size and density/intensity standards
 - Connectivity
 - Site orientation
 - Public realm enhancements
 - Ground floor design and use
 - Transition to neighborhoods



IMPLEMENTATION STRATEGIES

Plan Adoption and Implementation Steps

01

Amend City's Comprehensive Plan to create Activity Center category Ordinance 2023-15

02

Initial City action to adopt Activity Center Plan Ordinance 2023-01
Initial City action to amend Future Land Use map Ordinance 2023-02

03

CPA Meeting
02/20/2024

Amend Countywide Plan to establish Activity Center on the Countywide Plan Map and the Land Use Strategy Map (PAC/PPC/CPA)

04

BOC Meeting
03/13/2024

Final City action to adopt Activity Center Plan Ordinance 2023-01
Final City action to amend Future Land Use map Ordinance 2023-02

05

Amend City's Land Development Code to establish Activity Center zoning districts

Administer and implement the Activity Center Plan



Public Workshop

John's Pass Village Activity Center Zoning



Thursday 1/18/2024 1:00 PM-3:00 PM • Tuesday 1/23/2024 10:00 AM - 12:00 PM

Saturday 1/27/24 10:00 AM-12:00 PM

The Community Development Team will make a brief presentation and open workshop stations will follow. Three meetings are scheduled. All meetings have the same agenda.

Come to the one that works best for you.

300 Municipal Drive Second Floor Commission Chambers

Refreshments will be served

Boardwalk



- **Allowed Uses:** Commercial, Commercial Recreation, and Services
- **Intensity:** FAR 1.5
- **Density:** Residential 0 UPA and Temporary Lodging 0 UPA



Commercial Core



- **Allowed Uses:** Residential, Temporary Lodging, and Commercial
- **Intensity:** FAR 2.0, and FAR 2.2-3.0 with Development Agreement
- **Density:** Residential 15 UPA, Temporary Lodging 60 UPA, and Temporary Lodging 75-100 UPA with Development Agreement



John's Pass Resort

- **Allowed Uses:** Residential, Temporary Lodging, and Commercial only up to 20 percent of the building floor area
- **Intensity:** FAR 2.0, and FAR 2.2-2.5 with Development Agreement
- **Density:** Residential 18 UPA, Temporary Lodging 60 UPA, and Temporary Lodging 75-100 UPA with Development Agreement



Low Intensity Mixed Use

- **Allowed Uses:** Residential, Temporary Lodging, and Commercial only up to 20 percent of the building floor area.
- **Intensity:** FAR 1.5, and 2.0 with Development Agreement
- **Density:** Residential 18 UPA, Temporary Lodging 40 UPA, and 60 UPA with Development Agreement.



Traditional Village

- **Allowed Uses:** Residential, Temporary Lodging, and Commercial.
- **Intensity:** FAR 2.0
- **Density:** Residential 15 UPA, and Temporary Lodging 45 UPA



Transitional

- **Allowed Uses:** retail and services, restaurant, office, temporary lodging, and residential units (Commercial only up to 20 percent of the building floor area on Westside of Gulf Boulevard).
- **Intensity:** FAR 1.5, and 2.0 FAR with Development Agreement
- **Density:** Residential 18 UPA, Temporary Lodging 50 UPA, and Temporary Lodging 75 UPA with Development Agreement

