

Call Us first, for all of your Fleet Automotive, & Light Truck needs.

Quote

PHONE (800) ALANJAY (252-6529)		DIRECT 863-402-4234	WWW.ALANJAY.COM	52178-2
Corporate Office	2003 U.S. 27 South Sebring, FL 33870	MOBILE 863-273-1105	Mailing Address	P.O. BOX 9200 Sebring, FL 33871-9200
		FAX 863-402-4221		

ORIGINAL QUOTE DATE  
1/29/2024

## QUICK QUOTE SHEET

REVISED QUOTE DATE  
1/29/2024

REQUESTING AGENCY	MADEIRA BEACH, CITY OF		
CONTACT PERSON	MEGAN WEPFER	EMAIL	<a href="mailto:mwepfer@madeirabeachfl.gov">mwepfer@madeirabeachfl.gov</a>
PHONE	727-543-8154	MOBILE	FAX

### CONTRACT NUMBER 5179 - 2023 CITY OF TALLAHASSEE

MODEL	CC56403 R7N 1WT	MSRP	\$63,301.64
	2023 CHEVY SILVERADO 5500 MEDIUM DUTY REGULAR CAB 2WD 1WT 60" CA		
CUSTOMER ID		GOVERNMENT PRICE	\$49,590.00
BED LENGTH	60"CA		

\*\* All vehicles will be ordered white w/ darkest interior unless clearly stated otherwise on purchase order.

#### FACTORY OPTIONS

#### DESCRIPTION

FACTORY OPTIONS	DESCRIPTION	
066	OPTIONS Rear axle, 4.10 ratio	\$0.00
1WT	Work Truck Preferred Equipment Group	\$0.00
9L3	Spare tire delete	\$0.00
A31	Windows, power with driver express up and down and express down on all other windows	\$285.00
AE7	Seats, front 40/20/40 split-bench, 3-passenger	\$0.00
AQQ	Remote Keyless Entry	\$170.00
BJA	Fuel Fill Kit	\$120.00
BTN	Battery, top post threaded, battery jump start stud	\$45.00
DPN	Mirrors, outside heated power-adjustable vertical trailing, upper glass, manual-folding and extending, black.	\$350.00
ED9	Wheelbase, 165" (419.1 cm), 84" CA	\$170.00
F59	Front stabilizer bar	\$170.00
FTC	Front axle, 6,250 lb. (2,835 kg), Dana Spicer D800-N, "I"-beam, non-driving	\$0.00
FTW	Front suspension, 6,250 lb. (2,835 kg) multi-leaf, includes shock absorbers	\$0.00
G68	Shock Absorbers, rear	\$0.00
G7C	Red Hot	\$0.00
G86	Axle, limited slip, Dana Spicer Truetrac, torque proportioning limited slip	\$390.00
GR4	Rear suspension, 13,500 lb. (6,123 kg) multi-leaf, vari-rate	\$20.00
GZG	GVWR, 19,500 lb. (8845 kg)	\$2,250.00
H2Q	Dark Ash seats with Jet Black interior accents, Vinyl seat trim	\$0.00
HD2	Rear axle, 13,500 lb. (6,124 kg) Dana Spicer S14-110, single reduction	\$350.00
IOB	Audio system, 7" diagonal color touch-screen with Chevrolet Infotainment	\$270.00
L5D	Engine, Duramax 6.6L Turbo-Diesel V8, B20-Diesel compatible	\$0.00
MIU	Rugged Duty Service Transmission, Automatic close-ratio 6 SPD with double overdrive, Allison, A1700RDS	\$285.00
N12	Exhaust system, rear exit	\$45.00
PTO	Power Take Off, engine control provisions	\$275.00
PWR	Wheels, 19.5" x 6.75", steel, Grey painted, 8-holes, hub piloted	\$75.00
R6G	26,000 lb. GCWR (11,793 kg)	\$0.00
R7N	5500 HD Series	\$0.00
UQ3	6-speaker audio system	\$0.00
V76	Recovery hooks, front, frame-mounted, Black	\$20.00
XDK	Tires, front 225/70R19.5G highway blackwall Goodyear	\$0.00
YAL	Tires, rear 225/70R19.5G highway blackwall Goodyear	\$0.00
ZY1	Paint, solid	\$0.00
	Bluetooth for phone, personal cell phone connectivity to vehicle audio system	\$0.00

FACTORY OPTIONS \$5,290.00

### CONTRACT NUMBER 5179 - 2023 CITY OF TALLAHASSEE

AFTERMARKET OPTIONS	DESCRIPTION	
CHASSIS ONLY	CUSTOMER TO FACILITATE COMPLETED VEHICLE CERTIFICATION & REGISTER WITH 2ND STAGE MSO AT A LATER TIME ONCE BODY IS SWAPPED.	\$0.00
EWD	EXTENDED WARRANTY DECLINED	\$0.00
NO-TEMP	TEMP TAG NOT REQUESTED, CUSTOMER WILL HANDLE THEIR OWN TAG WORK.	\$0.00
<b>AFTERMARKET OPTIONS</b>		<b>\$0.00</b>

<b>TRADE IN</b>	<b>TOTAL COST</b>	<b>\$54,880.00</b>
YES WE TAKE TRADE INS ~~~ ASK ABOUT MUNICIPAL FINANCING ~~~		\$0.00
<b>TOTAL COST LESS TRADE IN(S)</b>		<b>QTY 1 \$54,880.00</b>

Estimated Annual payments for 60 months paid in advance: \$12,290.86  
Municipal finance for any essential use vehicle, requires lender approval, WAC.

**Comments**      **ORDERED UNIT VIN: [PH624540]**

VEHICLE QUOTED BY      **ASHLEE WILSON**      GOVERNMENT ACCOUNT MANAGER      [Ashlee.Wilson@AlanJay.com](mailto:Ashlee.Wilson@AlanJay.com)

*"I Want to be Your Fleet Provider"*

*I appreciate the opportunity to submit this quotation. Please review it carefully. If there are any errors or changes, please feel free to contact me at any time. I am always happy to be of assistance.*



# Alan Jay Fleet Sales

Chris Wilson | 863-402-4234 | chris.wilson@alanjay.com



Vehicle: [Fleet] 2023 Chevrolet Silverado MD (CC56403) 2WD Reg Cab Work Truck ( Complete )



**Note:Photo may not represent exact vehicle or selected equipment.**

## Window Sticker

### SUMMARY

[Fleet] 2023 Chevrolet Silverado MD (CC56403) 2WD Reg Cab Work Truck

MSRP:\$56,105.00

Interior:Dark Ash seats with Jet Black interior accents, Vinyl seat trim

Exterior 1:Red Hot

Exterior 2:No color has been selected.

Engine, Duramax 6.6L Turbo-Diesel V8, B20-Diesel compatible

Rugged Duty Service Transmission, Automatic close-ratio 6 SPD with double overdrive, Allison, A1700RDS

### OPTIONS

CODE	MODEL	MSRP
CC56403	[Fleet] 2023 Chevrolet Silverado MD (CC56403) 2WD Reg Cab Work Truck	\$56,105.00
<b>OPTIONS</b>		
066	Rear axle, 4.10 ratio	\$0.00
1WT	Work Truck Preferred Equipment Group	\$0.00
9L3	Spare tire delete	\$0.00
A31	Windows, power with driver express up and down and express down on all other windows	\$290.00
AE7	Seats, front 40/20/40 split-bench, 3-passenger	\$0.00
AQQ	Remote Keyless Entry	\$175.00
BJA	Fuel Fill Kit	\$125.00
BTN	Battery, top post threaded, battery jump start stud	\$50.00
DPN	Mirrors, outside heated power-adjustable vertical trailing, upper glass, manual-folding and extending, black.	\$355.00
ED9	Wheelbase, 165" (419.1 cm), 84" CA	\$175.00
F59	Front stabilizer bar	\$175.00

This document contains information considered Confidential between GM and its Clients uniquely. The information provided is not intended for public disclosure. Prices, specifications, and availability are subject to change without notice, and do not include certain fees, taxes and charges that may be required by law or vary by manufacturer or region. Performance figures are guidelines only, and actual performance may vary. Photos may not represent actual vehicles or exact configurations. Content based on report preparer's input is subject to the accuracy of the input provided.

Data Version: 17875. Data Updated: Nov 3, 2022 6:50:00 PM PDT.



# Alan Jay Fleet Sales

Chris Wilson | 863-402-4234 | chris.wilson@alanjay.com

Vehicle: [Fleet] 2023 Chevrolet Silverado MD (CC56403) 2WD Reg Cab Work Truck (✔ Complete)

FTC	Front axle, 6,250 lb. (2,835 kg), Dana Spicer D800-N, "I"-beam, non-driving		\$0.00
FTW	Front suspension, 6,250 lb. (2,835 kg) multi-leaf, includes shock absorbers		\$0.00
G68	Shock Absorbers, rear	Inc.	
G7C	Red Hot		\$0.00
G86	Axle, limited slip, Dana Spicer Truetrac, torque proportioning limited slip		\$395.00
GR4	Rear suspension, 13,500 lb. (6,123 kg) multi-leaf, vari-rate		\$25.00
GZG	GVWR, 19,500 lb. (8845 kg)		\$2,255.00
H2Q	Dark Ash seats with Jet Black interior accents, Vinyl seat trim		\$0.00
HD2	Rear axle, 13,500 lb. (6,124 kg) Dana Spicer S14-110, single reduction		\$355.00
IOB	Audio system, 7" diagonal color touch-screen with Chevrolet Infotainment		\$275.00
L5D	Engine, Duramax 6.6L Turbo-Diesel V8, B20-Diesel compatible		\$0.00
MIU	Rugged Duty Service Transmission, Automatic close-ratio 6 SPD with double overdrive, Allison, A1700RDS		\$290.00
N12	Exhaust system, rear exit		\$50.00
PTO	Power Take Off, engine control provisions		\$280.00
PWR	Wheels, 19.5" x 6.75", steel, Grey painted, 8-holes, hub piloted		\$80.00
R6G	26,000 lb. GCWR (11,793 kg)		\$0.00
R7N	5500 HD Series	Inc.	
UQ3	6-speaker audio system	Inc.	
V76	Recovery hooks, front, frame-mounted, black		\$25.00
XDK	Tires, front 225/70R19.5G highway blackwall Goodyear		\$0.00
YAL	Tires, rear 225/70R19.5G highway blackwall Goodyear		\$0.00
ZY1	Paint, solid		\$0.00
—	Bluetooth for phone, personal cell phone connectivity to vehicle audio system	Inc.	

<b>SUBTOTAL</b>	<b>\$61,480.00</b>
Adjustments Total	\$0.00
Tire Weight Tax	\$26.64
Destination Charge	\$1,795.00

This document contains information considered Confidential between GM and its Clients uniquely. The information provided is not intended for public disclosure. Prices, specifications, and availability are subject to change without notice, and do not include certain fees, taxes and charges that may be required by law or vary by manufacturer or region. Performance figures are guidelines only, and actual performance may vary. Photos may not represent actual vehicles or exact configurations. Content based on report preparer's input is subject to the accuracy of the input provided.

Data Version: 17875. Data Updated: Nov 3, 2022 6:50:00 PM PDT.



# Alan Jay Fleet Sales

Chris Wilson | 863-402-4234 | chris.wilson@alanjay.com

Vehicle: [Fleet] 2023 Chevrolet Silverado MD (CC56403) 2WD Reg Cab Work Truck ( Complete )

**TOTAL PRICE**

**\$63,301.64**

## Standard Equipment

### Mechanical

GVWR, 16,500 lb. (7484 kg) (Silverado 4500 HD 2WD Regular Cab models require one of the following combinations: (1) (FTC) 6.25k front axle and (FTW) 6.25k front suspension and (GL4) 11k rear axle and (GR3) 11k rear suspension. (2) (FTC) 6.25k front axle and (FTW) 6.25k front suspension and one of the following rear axles: (HD2) 13.5k rear axle, (HD1) 15k rear axle or (J27) 15.5k rear axle and (GR4) 13.5k rear suspension. (3) (FTA) 7k front axle and (FK6) 7k front suspension and (FN1) 10k rear axle or (GL4) 11k rear axle and (GR3) 11k rear suspension or (G40) 12K Rear air suspension. (4) (FTA) 7k front axle and (FK6) 7k front suspension and (HD1) 15k rear axle or (J27) 15.5k rear axle and one of the following rear suspensions: (GR4) 13.5k rear suspension, (FU7) 15.5k rear suspension, (GP1) 13.5K rear air suspension, (GP8) 15.5k rear air suspension, (91B) 13.5k LiquidSpring prep single volume rear suspension, (91C) 13.5k LiquidSpring prep stacked volume rear suspension, (91D) 15.5k LiquidSpring prep single volume rear suspension or (91E) 15.5k LiquidSpring prep stacked volume rear suspension.) (STD)

Emissions, 50 state certification

Emissions, USA 50 State certified

Engine, Duramax 6.6L Turbo-Diesel V8, B20-Diesel compatible 350 hp @ 2700 rpm, 700 lb.-ft. torque @ 1600 rpm (STD)

Highway Service Transmission, Automatic close-ratio 6 SPD with double overdrive, Allison, A1700HS ratios: 3.10 1ST, 1.80 2ND, 1.40 3RD, 1.00 4TH, 0.70 5TH, 0.61 6TH Highway Series, 19.5K GVW & 26K GCW Max., requires PTX and park pawl. Available with GVWs less than or equal to 19.5K (Requires (C7Y) 14,001 lb. GVWR, (C5B) 15,000 lb. GVWR, (C7P) 16,000 lb. GVWR, (C7R) 16,500 lb. GVWR, (GZX) 17,500 lb. GVWR, (GZJ) 18,000 lb. GVWR or (GZG) 19,500 lb. GVWR. Requires (R6G) 26,000 lb. GCWR (11,793 kg).) (STD)

Rear axle, 4.10 ratio Max road speed: 79 MPH

Wheelbase, 141" (358.1 cm), 60" CA (Requires (F0C) 49" axle to end of frame, (F0D) 63" axle to end of frame or (F0K) 91" axle to end of frame and (NPR) exhaust. Requires (PCJ) Vocational Specific Heavy Suspension Package, when ordering (FTA) 7,000 lb. Front axle/(FK6) 7,000 lb. Front suspension or (FTL) 8,000 lb. Front axle/(FSN) 8,000 lb. Front suspension and/or (FU7) 15,500 lb. rear suspension. Not available with rear air suspensions or (91B), (91C), (91D) or (91E) prep for LiquidSpring rear suspension.) (STD)

Front axle, 6,250 lb. (2,835 kg), Dana Spicer D800-N, "I"-beam, non-driving (Requires (FTW) 6,250 lb. front suspension. Includes (G68) rear shock absorbers. Not available with rear air suspensions.)

Front suspension, 6,250 lb. (2,835 kg) multi-leaf, includes shock absorbers (Not available with rear air suspensions.) (STD)

Rear axle, 11,000 lb. (4,999 kg) Dana Spicer S14-110, single reduction

Rear suspension, 11,000 lb. (4,990 kg) multi-leaf, vari-rate (Not available with air suspension.) (STD)

Neutral-at-Stop Automatic transmission shifts to neutral when the service brake is depressed while the vehicle is at a complete stop, and remains in neutral until the service brake is released

Transmission shift control calibration, fuel sense Performance

Rear wheel drive

Batteries, heavy-duty dual 1100 cold-cranking amps includes battery box mounted to left side under cab

This document contains information considered Confidential between GM and its Clients uniquely. The information provided is not intended for public disclosure. Prices, specifications, and availability are subject to change without notice, and do not include certain fees, taxes and charges that may be required by law or vary by manufacturer or region. Performance figures are guidelines only, and actual performance may vary. Photos may not represent actual vehicles or exact configurations. Content based on report preparer's input is subject to the accuracy of the input provided.

Data Version: 17875. Data Updated: Nov 3, 2022 6:50:00 PM PDT.



# Alan Jay Fleet Sales

Chris Wilson | 863-402-4234 | chris.wilson@alanjay.com

Vehicle: [Fleet] 2023 Chevrolet Silverado MD (CC56403) 2WD Reg Cab Work Truck (✔ Complete)

## Mechanical

- Alternator, 150 amps
- Trailing provisions, trailing wire harness only, trailer combined (Stop/Tail/Turn) connection socket and harness mounted at rear of frame.
- Trailer brake controller, integrated
- Incomplete vehicle
- Axle to End of Frame, 49" (Requires wheelbase (ED5) 201", (ED9) 165", (ER2) 189" or (FQT) 141". Not available with (G40), (GP1) or (GP8) rear air suspension.)
- Axle, Open rear axle, non-locking rear
- Axle lubricant, rear, synthetic oil EmGard FE -75W-90
- Shock Absorbers, rear (Included with (FTC) 6,250 lb. front axle.)
- Steering, power (Bosch S2 8014 Plus)
- Brakes, hydraulic, heavy duty Bosch/Meritor/Wabco system with 4-channel (ABS) (Includes (J69) driveline park brake.)
- Fuel tank, rear only, 40 gallon mounted between frame side rails and behind rear axle
- Fuel, diesel B20
- Capped Fuel Fill
- Exhaust system, right side exit, behind rear wheels (Requires (FQT) 141" wheelbase.)
- Exhaust brake

## Exterior

- Wheels, 19.5" x 6.75", steel, Black painted, 8-holes, hub piloted (STD)
- Tires, front 225/70R19.5G highway blackwall Goodyear Max Axle Load: 7,940 lb. (Requires (YAL) Tires, rear 225/70R19.5G highway blackwall Goodyear, Max Axle Load: 15,000 lb. or (YMF) Tires, rear 225/70R19.5G traction blackwall Goodyear, Max Axle Load: 15,000 lb.) (STD)
- Tires, rear 225/70R19.5G highway blackwall Goodyear Max Axle Load: 15,000 lb. (STD)
- Spare tire delete (STD)
- Wheel, spare delete
- Bumper, front, Black
- Assist steps
- Front fender extension, painted body color
- Grille, base, molded in color, Black
- Grille guard screen, insect protection (mounted behind grille)
- Headlamps, halogen projector-beam

This document contains information considered Confidential between GM and its Clients uniquely. The information provided is not intended for public disclosure. Prices, specifications, and availability are subject to change without notice, and do not include certain fees, taxes and charges that may be required by law or vary by manufacturer or region. Performance figures are guidelines only, and actual performance may vary. Photos may not represent actual vehicles or exact configurations. Content based on report preparer's input is subject to the accuracy of the input provided.  
 Data Version: 17875. Data Updated: Nov 3, 2022 6:50:00 PM PDT.



# Alan Jay Fleet Sales

Chris Wilson | 863-402-4234 | chris.wilson@alanjay.com

Vehicle: [Fleet] 2023 Chevrolet Silverado MD (CC56403) 2WD Reg Cab Work Truck (  Complete )

## Exterior

Lamps, cargo area, cab mounted with switch on center switch bank

Lamps, Smoked Amber roof marker

Lamps, rear, stop/turn/backup (1-piece assembly) with license plate light

Mirrors, outside high-visibility vertical camper-style, Black with manual folding and extension and lower convex spotter glass

Glass, solar absorbing, tinted

Antenna, fixed mast

Door handles, Black

## Entertainment

Audio system, 4.2" diagonal color display AM/FM stereo with USB port and auxiliary jack (Requires (AE7) front 40/20/40 split-bench seat. Not available with (UE1) OnStar or (U2K) SiriusXM Radio.) (STD)

SiriusXM, delete

Audio system feature, 4-speaker system

## Interior

Seats, front 40/20/40 split-bench, 3-passenger driver and front passenger recline with outboard head restraints and center fold-down armrest with storage. Vinyl has fixed lumbar and cloth has manually adjustable driver lumbar. (STD)

Interior trim, Jet Black/Dark Ash (Required and only available with (H2Q/H2R) Dark Ash seats with Jet Black interior accents.)

Seat trim, Vinyl

Seat Belt, Black

Floor covering, Graphite-colored rubberized-vinyl

Steering wheel, urethane

Steering column, manual Tilt-Wheel

Instrumentation, 6-gauge cluster featuring speedometer, fuel level, engine temperature, tachometer, voltage and oil pressure

Speedometer, miles/kilometers

Driver Information Center, 3.5-inch diagonal monochromatic display, provides warning messages and basic vehicle information

Upfitter switch kit provides up to 4-30 amp circuits to facilitate installation of aftermarket electrical accessories located on the instrument panel

Windows, manual driver and front passenger

Door locks, power

This document contains information considered Confidential between GM and its Clients uniquely. The information provided is not intended for public disclosure. Prices, specifications, and availability are subject to change without notice, and do not include certain fees, taxes and charges that may be required by law or vary by manufacturer or region. Performance figures are guidelines only, and actual performance may vary. Photos may not represent actual vehicles or exact configurations. Content based on report preparer's input is subject to the accuracy of the input provided.

Data Version: 17875. Data Updated: Nov 3, 2022 6:50:00 PM PDT.



# Alan Jay Fleet Sales

Chris Wilson | 863-402-4234 | chris.wilson@alanjay.com

Vehicle: [Fleet] 2023 Chevrolet Silverado MD (CC56403) 2WD Reg Cab Work Truck (  Complete )

## Interior

Cruise control, steering wheel-mounted

Air conditioning, single-zone

Mirror, inside rearview manual day/night

Visors, driver and front passenger, vinyl

Assist handle, front passenger and driver on A-pillars

## Safety-Mechanical

Brake, parking, driveline park brake system

StabiliTrak, Electronic Stability Control System with Traction Control includes Electronic Trailer Sway Control and Hill Start Assist

Traction control

## Safety-Exterior

Daytime Running Lamps, with automatic exterior lamp control

## Safety-Interior

Airbags, Single-stage frontal airbags for driver and front outboard passenger; Seat-mounted side-impact airbags for driver and front outboard passenger; Head-curtain airbags for front outboard seating positions; Includes airbag deactivation switch for front outboard passenger airbag (Always use seat belts and child restraints. Children are safer when properly secured in a rear seat in the appropriate child restraint. See the Owner's Manual for more information.)

Airbag deactivation switch, frontal passenger-side (Included and only available with (AY0) airbags.)

OnStar, delete

Rear Vision Camera, display integrated into Radio (Shipped loose in cab for upfitter installation.)

Horn, single-note

This document contains information considered Confidential between GM and its Clients uniquely. The information provided is not intended for public disclosure. Prices, specifications, and availability are subject to change without notice, and do not include certain fees, taxes and charges that may be required by law or vary by manufacturer or region. Performance figures are guidelines only, and actual performance may vary. Photos may not represent actual vehicles or exact configurations. Content based on report preparer's input is subject to the accuracy of the input provided.

Data Version: 17875. Data Updated: Nov 3, 2022 6:50:00 PM PDT.





## Alan Jay Fleet Sales

Chris Wilson | 863-402-4234 | chris.wilson@alanjay.com

Vehicle: [Fleet] 2023 Chevrolet Silverado MD (CC56403) 2WD Reg Cab Work Truck (  Complete )

### WARRANTY

Warranty Note: <<< Preliminary 2023 Warranty >>>  
Basic Years: 3  
Basic Miles/km: 36,000  
Drivetrain Years (Allison Basic): 5  
Drivetrain Years: 5  
Drivetrain Miles/km (Allison Basic): Unlimited  
Drivetrain Miles/km: 100,000  
Drivetrain Note: Duramax Diesel  
Corrosion Years (Rust-Through): 6  
Corrosion Years: 3  
Corrosion Miles/km (Rust-Through): 100,000  
Corrosion Miles/km: 36,000  
Roadside Assistance Years: 5  
Roadside Assistance Miles/km: 100,000  
Maintenance Note: 1 Year/1 Visit

This document contains information considered Confidential between GM and its Clients uniquely. The information provided is not intended for public disclosure. Prices, specifications, and availability are subject to change without notice, and do not include certain fees, taxes and charges that may be required by law or vary by manufacturer or region. Performance figures are guidelines only, and actual performance may vary. Photos may not represent actual vehicles or exact configurations. Content based on report preparer's input is subject to the accuracy of the input provided.

Data Version: 17875. Data Updated: Nov 3, 2022 6:50:00 PM PDT.



# Alan Jay Fleet Sales

Chris Wilson | 863-402-4234 | chris.wilson@alanjay.com

Vehicle: [Fleet] 2023 Chevrolet Silverado MD (CC56403) 2WD Reg Cab Work Truck (✔ Complete)

## Technical Specifications

### Dimensions

#### Interior Dimensions

Passenger Capacity	3	Front Head Room	42.8 in
Front Leg Room	45.28 in	Front Shoulder Room	66.02 in
Front Hip Room	60.75 in		

#### Exterior Dimensions

Wheelbase	165 in	Length, Overall w/o rear bumper	N/A
Length, Overall	248.5 in	Width, Max w/o mirrors	92.7 in
Height, Overall	82.81 in	Overhang, Front	34.4 in
Overhang, Rear w/o bumper	49 in	Front Bumper to Back of Cab	115.47 in
Cab to Axle	84 in	Cab to End of Frame	133.1 in
Ground to Top of Load Floor	N/A	Ground to Top of Frame	N/A
Frame Width, Rear	34.1 in	Ground Clearance, Front	N/A
Ground Clearance, Rear	N/A	Body Length	0.0 ft
Cab to Body	3.0 in	Frontal Area	ft <sup>2</sup>

### Medium Duty

#### Medium Duty Performance

Front Axle %	63.64	Rear Axle %	36.36
Driver Weight	350.0 lbs	Front Ground Load	5085.00 lbs
Rear Ground Load	2905.00 lbs	1st gear High Speed (High Axle Gear)	21.39 MPH
2nd gear High Speed (High Axle Gear)	36.84 MPH	3rd gear High Speed (High Axle Gear)	47.36 MPH
4th gear High Speed (High Axle Gear)	66.31 MPH	5th gear High Speed (High Axle Gear)	94.73 MPH
6th gear High Speed (High Axle Gear)	108.71 MPH	1st gear Low Speed (High Axle Gear)	11.80 MPH
2nd gear Low Speed (High Axle Gear)	20.33 MPH	3rd gear Low Speed (High Axle Gear)	26.13 MPH
4th gear Low Speed (High Axle Gear)	36.59 MPH	5th gear Low Speed (High Axle Gear)	52.26 MPH
6th gear Low Speed (High Axle Gear)	59.98 MPH	1st gear High Speed (Low Axle Gear)	N/A
2nd gear High Speed (Low Axle Gear)	N/A	3rd gear High Speed (Low Axle Gear)	N/A
4th gear High Speed (Low Axle Gear)	N/A	5th gear High Speed (Low Axle Gear)	N/A

This document contains information considered Confidential between GM and its Clients uniquely. The information provided is not intended for public disclosure. Prices, specifications, and availability are subject to change without notice, and do not include certain fees, taxes and charges that may be required by law or vary by manufacturer or region. Performance figures are guidelines only, and actual performance may vary. Photos may not represent actual vehicles or exact configurations. Content based on report preparer's input is subject to the accuracy of the input provided.

Data Version: 17875. Data Updated: Nov 3, 2022 6:50:00 PM PDT.



# Alan Jay Fleet Sales

Chris Wilson | 863-402-4234 | chris.wilson@alanjay.com

Vehicle: [Fleet] 2023 Chevrolet Silverado MD (CC56403) 2WD Reg Cab Work Truck (✔ Complete)

## Medium Duty

### Medium Duty Performance

6th gear High Speed (Low Axle Gear)	N/A	1st gear Low Speed (Low Axle Gear)	N/A
2nd gear Low Speed (Low Axle Gear)	N/A	3rd gear Low Speed (Low Axle Gear)	N/A
4th gear Low Speed (Low Axle Gear)	N/A	5th gear Low Speed (Low Axle Gear)	N/A
6th gear Low Speed (Low Axle Gear)	N/A	Reduction	22.42
Torque @ Clutch Engage	N/A	Starting Grade Index	N/A
1st Gear Tractive Effort (High Axle Gear)	5921.84	2nd Gear Tractive Effort (High Axle Gear)	3438.49
3rd Gear Tractive Effort (High Axle Gear)	2674.38	4th Gear Tractive Effort (High Axle Gear)	1910.27
5th Gear Tractive Effort (High Axle Gear)	1337.19	6th Gear Tractive Effort (High Axle Gear)	1165.27
1st Gear Tractive Effort (Low Axle Gear)	N/A	2nd Gear Tractive Effort (Low Axle Gear)	N/A
3rd Gear Tractive Effort (Low Axle Gear)	N/A	4th Gear Tractive Effort (Low Axle Gear)	N/A
5th Gear Tractive Effort (Low Axle Gear)	N/A	6th Gear Tractive Effort (Low Axle Gear)	N/A
1st Gear Gradeability (High Axle Gear)	27.43	2nd Gear Gradeability (High Axle Gear)	14.86
3rd Gear Gradeability (High Axle Gear)	10.53	4th Gear Gradeability (High Axle Gear)	5.29
5th Gear Gradeability (High Axle Gear)	-0.76	6th Gear Gradeability (High Axle Gear)	-3.61
1st Gear Gradeability (Low Axle Gear)	50.71	2nd Gear Gradeability (Low Axle Gear)	28.95
3rd Gear Gradeability (Low Axle Gear)	22.11	4th Gear Gradeability (Low Axle Gear)	14.98
5th Gear Gradeability (Low Axle Gear)	8.97	6th Gear Gradeability (Low Axle Gear)	6.84
Geared Road Speed	108.71 MPH	Actual Loaded Speed	66.3 MPH In 4th Hi @ 2900 RPM MPH
Grade (%)	2.0	Maximum Speed Gradeability	14.2% @ 2539 RPM @ 79 MPH
Torque Converter	1.764	Maximum Capacity @ 0° F	2200.00
% of Body on Front Axle	49.09	% of Body on Rear Axle	50.91
Body Weight Front	0.00 lbs	Body Weight Rear	0.00 lbs
Actual Loaded Speed (First Part, MPH)	66.3 MPH	Actual Loaded Speed (Second Part, RPM)	2900
Actual Loaded Speed (Third Part, Gear)	4	Road Type	Concrete
Body Weight	0.0 lbs	Driver Weight Front	350.00 lbs
Driver Weight Rear	0.00 lbs	Medium Duty Body Type	None
Front Total Load	5085.00 lbs	Rear Total Load	2905.00 lbs

This document contains information considered Confidential between GM and its Clients uniquely. The information provided is not intended for public disclosure. Prices, specifications, and availability are subject to change without notice, and do not include certain fees, taxes and charges that may be required by law or vary by manufacturer or region. Performance figures are guidelines only, and actual performance may vary. Photos may not represent actual vehicles or exact configurations. Content based on report preparer's input is subject to the accuracy of the input provided.

Data Version: 17875. Data Updated: Nov 3, 2022 6:50:00 PM PDT.



# Alan Jay Fleet Sales

Chris Wilson | 863-402-4234 | chris.wilson@alanjay.com

Vehicle: [Fleet] 2023 Chevrolet Silverado MD (CC56403) 2WD Reg Cab Work Truck (✔ Complete)

## Weight Distribution

### SPECIFICATION SUMMARY

Model #	CC56403
Truck/Tractor	
Wheelbase (WB)	165 in
Cab to Axle (CA)	84 in
Cab to Body/Swing Clear (BOC)	3.0 in
Body Length	0.0 ft
Body Weight	0.0 lbs
Cargo Weight	0.00 lbs
Front GAWR	6250 lbs
Rear GAWR	13500 lbs
GVWR	19500.00 lbs

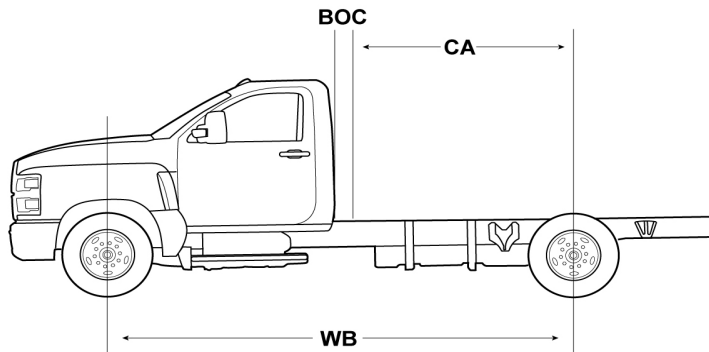

CA: 84 in  
 BOC: 3.0 in  
 WB: 165 in

<b>Fr%: 63.64</b>	<b>Rr%: 36.36</b>
<b>Front Wt: 5085.00 lbs</b>	<b>Rear Wt: 2905.00 lbs</b>

GAWR/GVWR	GVW	Remaining Payload Wt
19500.00 lbs	7990.00 lbs	11,510.00 lbs

This document contains information considered Confidential between GM and its Clients uniquely. The information provided is not intended for public disclosure. Prices, specifications, and availability are subject to change without notice, and do not include certain fees, taxes and charges that may be required by law or vary by manufacturer or region. Performance figures are guidelines only, and actual performance may vary. Photos may not represent actual vehicles or exact configurations. Content based on report preparer's input is subject to the accuracy of the input provided.

Data Version: 17875. Data Updated: Nov 3, 2022 6:50:00 PM PDT.



# Alan Jay Fleet Sales

Chris Wilson | 863-402-4234 | chris.wilson@alanjay.com

Vehicle: [Fleet] 2023 Chevrolet Silverado MD (CC56403) 2WD Reg Cab Work Truck ( Complete )

## Weight Distribution

### SPECIFICATION DETAILS

	Front Axle	Rear Axle	Total
<b>Actual</b>			
Chassis	4735.00 lbs	2905.00 lbs	7640.00 lbs
Body	0.00 lbs	0.00 lbs	0.0 lbs
Payload	0.00 lbs	0.00 lbs	0.00 lbs
Trailer			0.0 lbs
Totals	5085.00 lbs	2905.00 lbs	7990.00 lbs
<b>Capacity</b>			
Axle	6250 lbs	13500 lbs	19750.00 lbs
Suspension	6250 lbs	13500 lbs	19,750.00 lbs
Tire	7940 lbs	15000 lbs	22940.00
Total Axle Rating	6250.00 lbs	13500.00 lbs	19750.00 lbs

This document contains information considered Confidential between GM and its Clients uniquely. The information provided is not intended for public disclosure. Prices, specifications, and availability are subject to change without notice, and do not include certain fees, taxes and charges that may be required by law or vary by manufacturer or region. Performance figures are guidelines only, and actual performance may vary. Photos may not represent actual vehicles or exact configurations. Content based on report preparer's input is subject to the accuracy of the input provided.

Data Version: 17875. Data Updated: Nov 3, 2022 6:50:00 PM PDT.



# Alan Jay Fleet Sales

Chris Wilson | 863-402-4234 | chris.wilson@alanjay.com

Vehicle: [Fleet] 2023 Chevrolet Silverado MD (CC56403) 2WD Reg Cab Work Truck (✔ Complete)

## Geared Road Speed

### SPECIFICATION SUMMARY

<b>Model #</b>	CC56403
<b>Engine Order Code</b>	L5D
Model Manufacturer	Duramax
Type	Turbocharged Diesel V8
Displacement	6.6L/402
Horsepower	350 @ 2700
Starting Torque	N/A
<b>Transmission Order Code</b>	MIU
Model Manufacturer	Allison
Type	6-Speed Automatic
<b>Rear Axle Order Code</b>	HD2
Model Manufacturer	A1700RDS Allison
Weight Rating	13500 lbs
Ratio:1	4.10
<b>Rear Tires</b>	225/70R19.5G
<b>Revolutions/Mile Front</b>	640
<b>Revolutions/Mile Rear</b>	640
<b>Surface Type</b>	Concrete
<b>Desired Grade</b>	2%

### Geared Road Speed

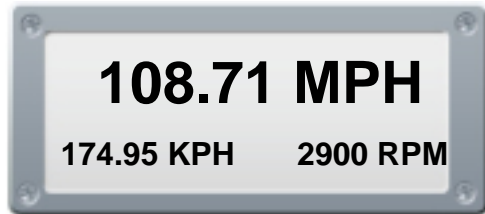

0% Grade in 4th gear

### Actual Loaded Speed

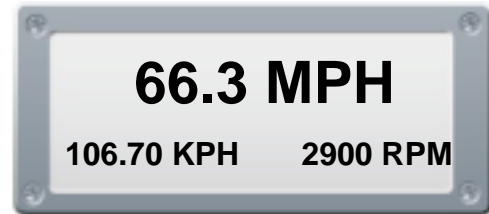

2% Grade in 4th gear

Note: Simulated speedometer appearance may not correspond with selected equipment.

This document contains information considered Confidential between GM and its Clients uniquely. The information provided is not intended for public disclosure. Prices, specifications, and availability are subject to change without notice, and do not include certain fees, taxes and charges that may be required by law or vary by manufacturer or region. Performance figures are guidelines only, and actual performance may vary. Photos may not represent actual vehicles or exact configurations. Content based on report preparer's input is subject to the accuracy of the input provided.

Data Version: 17875. Data Updated: Nov 3, 2022 6:50:00 PM PDT.



# Alan Jay Fleet Sales

Chris Wilson | 863-402-4234 | chris.wilson@alanjay.com

Vehicle: [Fleet] 2023 Chevrolet Silverado MD (CC56403) 2WD Reg Cab Work Truck (✔ Complete)

## Gradeability Chart

### SPECIFICATION SUMMARY

<b>Model #</b>	CC56403
<b>Engine Order Code</b>	L5D
Model Manufacturer	Duramax
Type	Turbocharged Diesel V8
Displacement	6.6L/402
Horsepower	350 @ 2700
Starting Torque	N/A
<b>Transmission Order Code</b>	MIU
Model Manufacturer	Allison
Type	6-Speed Automatic
<b>Rear Axle Order Code</b>	HD2
Model Manufacturer	A1700RDS Allison
Weight Rating	13500 lbs
Ratio:1	4.10
<b>Rear Tires</b>	225/70R19.5G
<b>Revolutions/Mile Front</b>	640
<b>Revolutions/Mile Rear</b>	640
<b>Surface Type</b>	Concrete
<b>Desired Grade</b>	2%

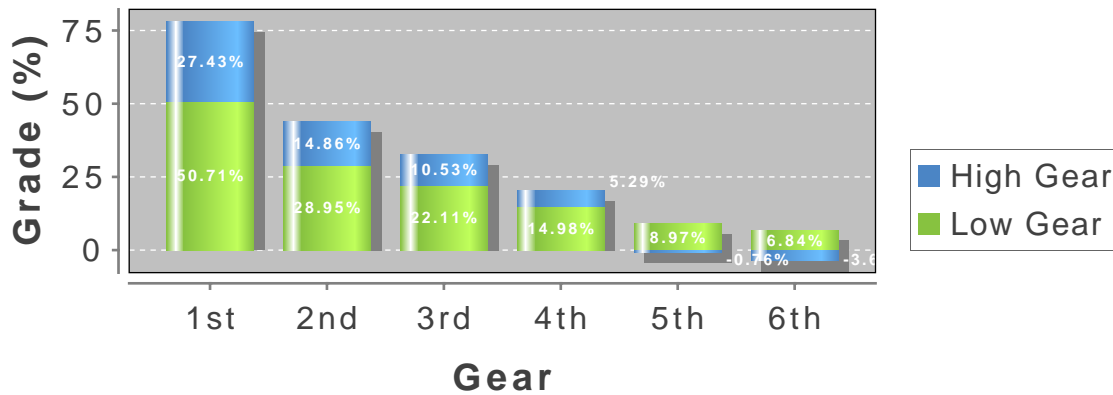

This document contains information considered Confidential between GM and its Clients uniquely. The information provided is not intended for public disclosure. Prices, specifications, and availability are subject to change without notice, and do not include certain fees, taxes and charges that may be required by law or vary by manufacturer or region. Performance figures are guidelines only, and actual performance may vary. Photos may not represent actual vehicles or exact configurations. Content based on report preparer's input is subject to the accuracy of the input provided.

Data Version: 17875. Data Updated: Nov 3, 2022 6:50:00 PM PDT.



# Alan Jay Fleet Sales

Chris Wilson | 863-402-4234 | chris.wilson@alanjay.com

Vehicle: [Fleet] 2023 Chevrolet Silverado MD (CC56403) 2WD Reg Cab Work Truck (✔ Complete)

## Turning Circle

### SPECIFICATION SUMMARY

<b>Model #</b>	CC56403
<b>Front Axle Order Code</b>	FTC
Capacity (lbs)	6250 lbs
<b>Wheelbase Order Code</b>	ED9
Wheelbase (in)	165 in
<b>Front Wheel Order Code</b>	
Size/Type (in)	19.5 x 6.75 in
<b>Front Tire Order Code</b>	XDK
Size/Type	225/70R19.5G

#### Wall to Wall (ft): 48.8 ft

Wall to Wall diameter is measured from the outermost part of the cab.

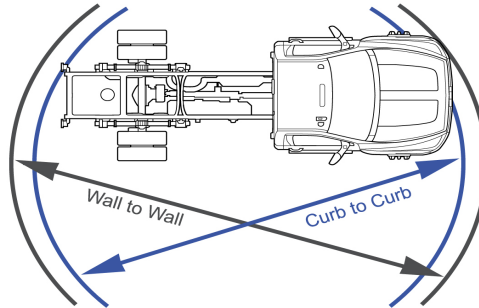

#### Curb to Curb (ft): 47.2 ft

Curb to Curb diameter is measured from the outside of the front tire.

This document contains information considered Confidential between GM and its Clients uniquely. The information provided is not intended for public disclosure. Prices, specifications, and availability are subject to change without notice, and do not include certain fees, taxes and charges that may be required by law or vary by manufacturer or region. Performance figures are guidelines only, and actual performance may vary. Photos may not represent actual vehicles or exact configurations. Content based on report preparer's input is subject to the accuracy of the input provided.

Data Version: 17875. Data Updated: Nov 3, 2022 6:50:00 PM PDT.





CHEVROLET

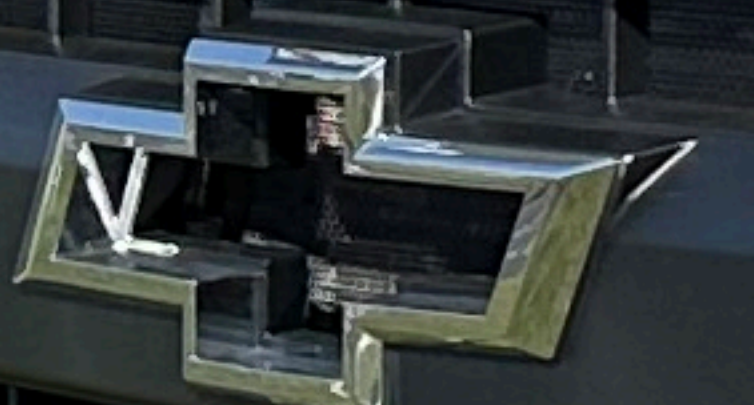

CERTIFIED  
CLEAN TITLE

SILVERADO  
5500 HD

273457864





GOVERNMENT  
CONTRACT  
SPECIALIST

ALAN JAY  
FLEET CENTER

ALAN JAY  
FLEET CENTER

PH571864

VIN 9-27-23

AA-2

GOODYEAR