

Priming Assisted Centrifugal Pump w/Autostart Model VPA6A60C-4LE2T FT4



Size 6" x 6"



Total Head		Capacity of Pump in U.S. Gallons per Minute (GPM) at Continuous Performance			
P.S.I.	Feet				
41.2	95	390	390	390	390
39.0	90	450	570	570	570
34.7	80	530	700	830	900
30.3	70	615	805	975	1110
26.0	60	690	900	1100	1245
21.7	50	760	1000	1175	1375
17.3	40	830	1080	1250	1485
13.0	30	870	1130	1320	1595
8.7	20	910	1185	1390	1650
Suction Lift		20'	15'	10'	5'



PUMP SPECIFICATIONS

- Size:** 6" x 6" (152 mm x 152 mm) Flanged.
- Casing:** Gray Iron 30.
Maximum Operating Pressure 62 psi (428 kPa).
Maximum Temperature of Liquid Pumped 160°F (71°C).*
- Semi-Open Type, Two Vane Impeller:** Ductile Iron 65-45-12.
Handles 3" (76,2 mm) Diameter Spherical Solids.
- Impeller Shaft:** Alloy Steel 4150.
- Replaceable Wear Plate:** Carbon Steel ASTM A36.
- Bearing Housing:** Gray Iron 30.
- Seal Plate:** Gray Iron 30.
- Seal:** Type 31, Mechanical, Oil-Lubricated. Silicon Carbide Rotating and Stationary Faces. Nitrile Elastomers. Stainless Steel 18-8 Cage and Spring.
- Shaft Sleeve:** Alloy Steel 4130.
- Priming Chamber:** Gray Iron 30 Housing w/Stainless Steel Float and Linkage.
- Discharge Check Valve:** Ductile Iron Housing with Welded Nickel Seat and Buna-N Flapper.
- Bearings:** Permanently Lubricated Single Row Ball.
- Seal Cavity Lubrication:** SAE 30 Non-Detergent Oil.
- Gaskets:** Red Rubber.
- O-Rings:** Buna-N.
- Hardware:** Standard Plated Steel.

*Consult Factory for Applications Exceeding Maximum Pressure and/or Temperature Indicated.

Standard Equipment: Belt-Driven Air Compressor. Hoisting Bail. Combination Skid Base w/Fuel Tank. Strainer. Standard Auto-start Control Panel [Single Ball Type Float Switch](#).**

Optional Equipment: Battery. Skid Drag Base Kit. High Speed (55 MPH/89 KM/H) Single Axle Pneumatic-Tired Wheel Kit w/ DOT-Approved Lights and Electric Brakes.

**50 Ft. (15 m) Standard Length; Dual Switches and Alternate Cable Lengths Available From the Factory.

WARNING!

Do not use in explosive atmosphere or for pumping volatile flammable liquids.

ENGINE SPECIFICATIONS

- Model:** Isuzu 4LE2T.
- EPA Tier:** Final Tier 4.
- Type:** Four Cylinder, Turbocharged Diesel Engine.
- Displacement:** 134 Cu. In. (2,2 Liters).
- Lubrication:** Forced Circulation.
- Governor:** Electronic.
- Air Cleaner:** Dry Type.
- Fuel Tank:** 34 U.S. Gals. (128,7 Liters).
- Full Load Operating Time:** 20.6 Hrs.
- Starter:** 12V Electric.
- Standard Features:** Muffler w/Weather Cap. DOC Exhaust After-Treatment System.
- Optional:** Electronic Fuel Level Sensor.
- Engine Control Features:** Padlockable Box with Throttle Control, Tachometer, Coolant Temperature, Oil Pressure, Voltage and Overstart Indicators/Shut-downs. Manual/Stop/Auto Keyswitch. Audible Startup Warning Delay. Fuel Level Display/Alarm/Shutdown (For Use With Optional Fuel Level Sensor).

ISUZU PUBLISHED PERFORMANCE:

Maximum Gross Continuous BHP
48 (35.8 kW) @ 2400 RPM



GORMAN-RUPP PUMPS

www.grpumps.com

Specifications Subject to Change Without Notice

Printed in U.S.A.

Specification Data

SECTION 41, PAGE 200

APPROXIMATE
DIMENSIONS and WEIGHTS

SKID BASE

NET WEIGHT: 1820 LBS. (825,5 KG.)
SHIPPING WEIGHT: 2070 LBS. (939,0 KG.)
EXPORT CRATE SIZE: 133.6 CU. FT. (3,8 CU. M.)

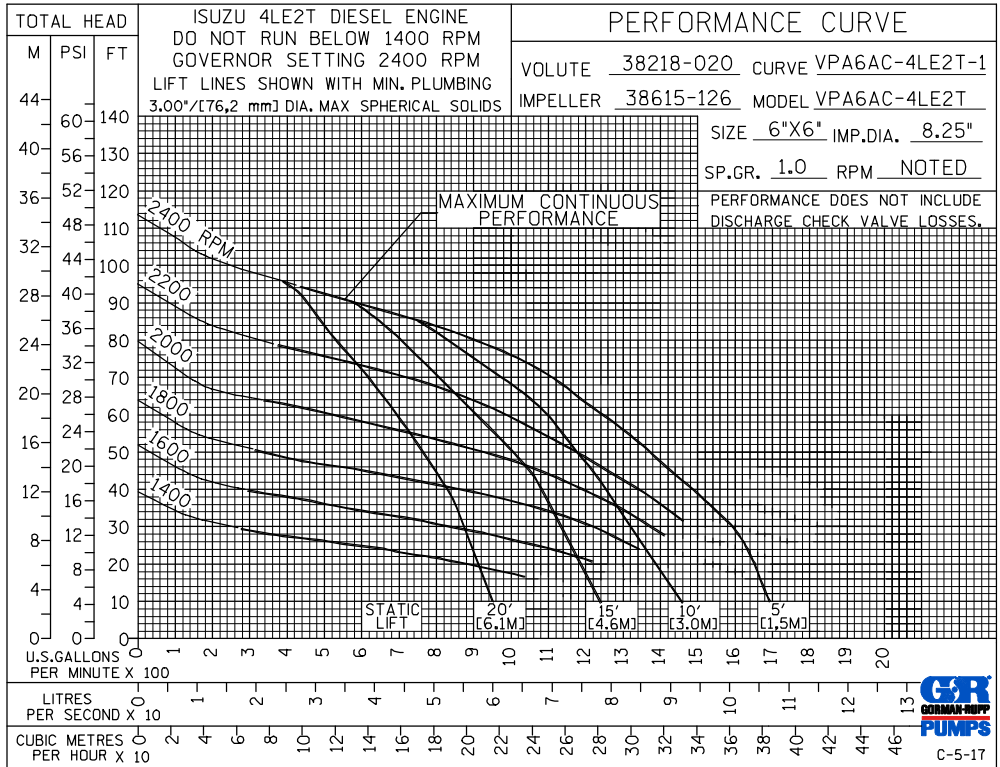
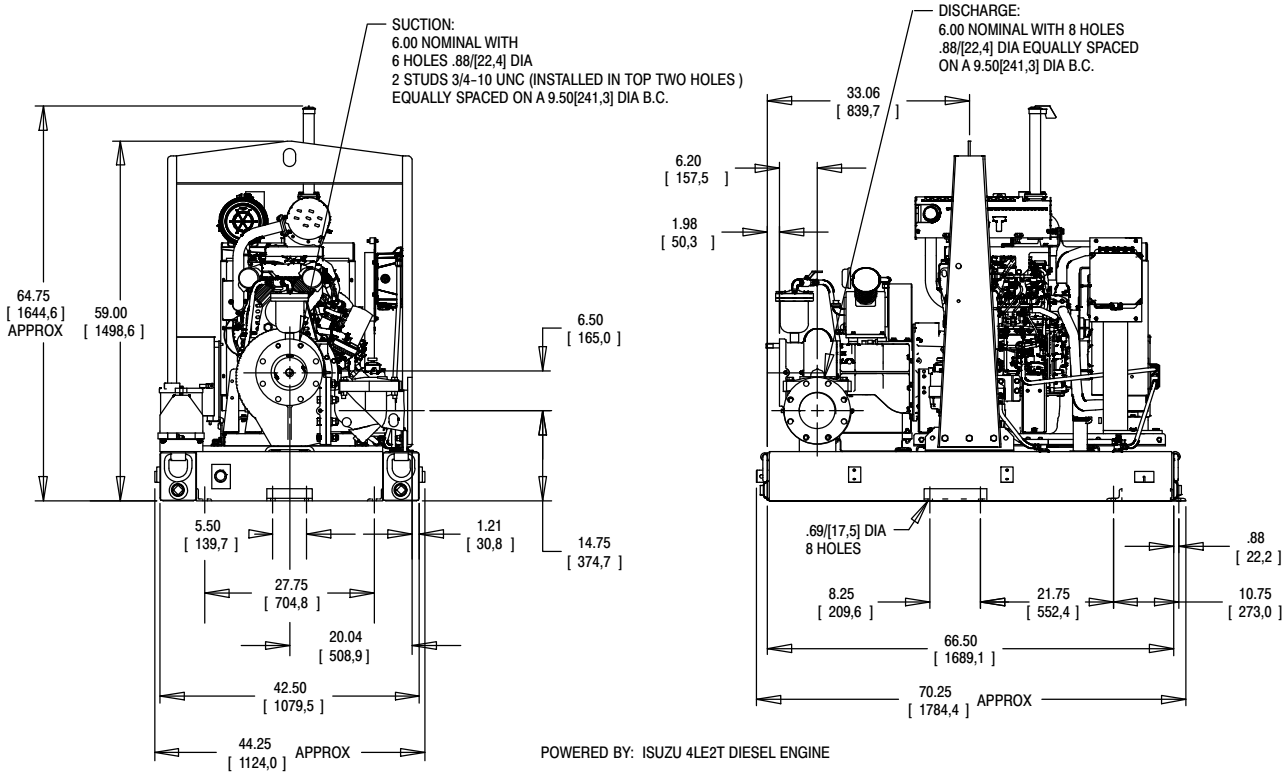

GORMAN-RUPP PUMPS

www.grpumps.com

Specifications Subject to Change Without Notice

Printed in U.S.A.