

WHELEN FREEDOM IV
72" L.E.D. LIGHTBAR

(13) WHELEN PIONEER
L.E.D. VISOR LIGHT

RETRACT HEATED/POHOTE
CONTROL RIBBING
WITH CONVEY SECTION

(13) WHELEN W6 L.E.D.
WARNING LIGHT
(13) WHELEN W6 L.E.D.
DIRECTIONAL LIGHT IN
A CORNER BUELL EACH SIDE

(12) WHELEN W6 L.E.D.
WARNING LIGHTS
EACH SIDE

(13) WHELEN S431SP SPEAKER
WITH SPEIL GRILLE

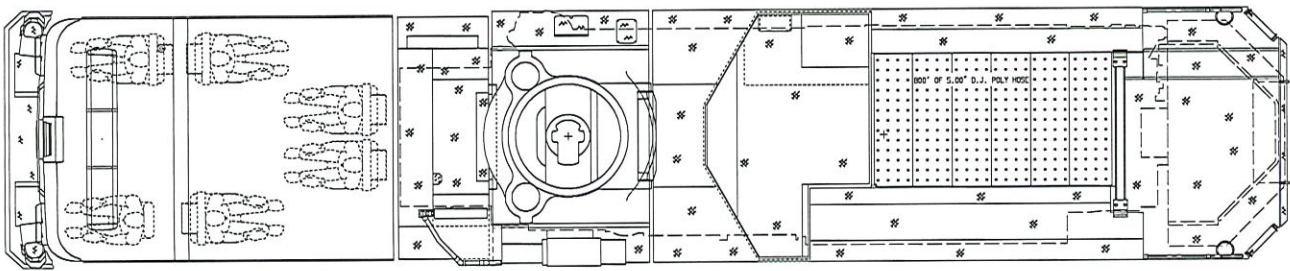

BODY 100' Ascendant Aerial Tower Alum Body COMPT, LEFT SIDE FULL Height RollUp Doors COMPT, RIGHT SIDE FULL Height RollUp Doors	WATER TANK 300 Gallon Poly Water Tank Foam System Foam System Not Required Foam Cell Foam Cell Not Required
---	---

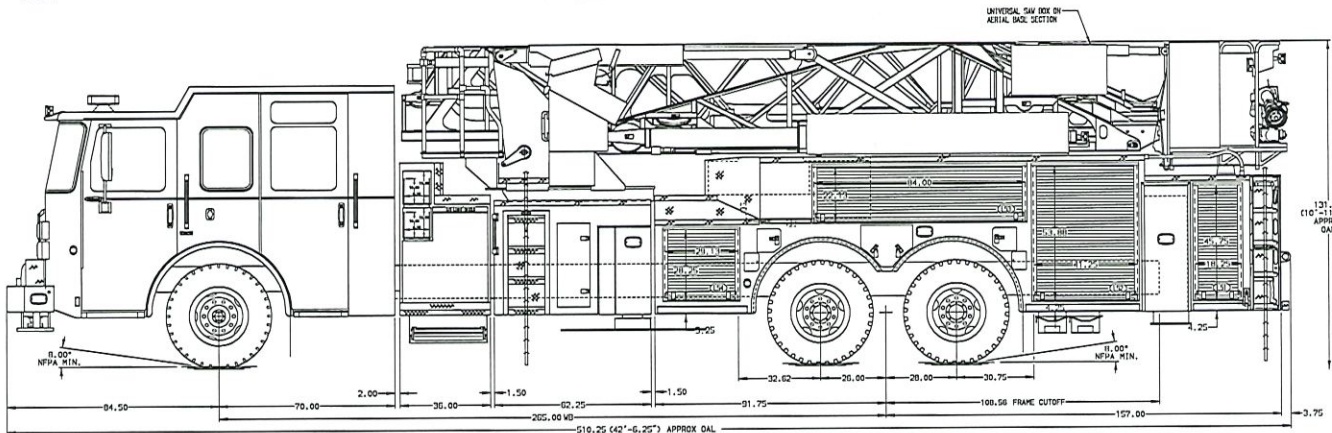

UNIVERSAL SAW BOX ON
AERIAL BASK SECTION

(13) WHELEN TALES L.E.D.
TRAFFIC DIRECTION LIGHT
WITH ARMY COVER

(12) WHELEN L318RN
L.E.D. WARNING LIGHTS

(12) WHELEN W6 L.E.D.
SCENE LIGHTS MOUNTED
ON 15 DEGREE BUELL

(12) WHELEN W6 L.E.D.
WARNING LIGHTS
STOP/PAUSE LIGHTS
DIRECTIONAL LIGHTS
BACK-UP LIGHTS
MOUNTED IN WHELEN
W6 PIERCE BUELLS

EQUIPMENT STORED
AT THE REAR
TWO 20" 2-SIDE 1200A
ONE 20" 2-SIDE 1200A
ONE 20" HOBI 1200A
ONE 10" HOBI 1200A
TWO 10" FOLDING SEGA
SIX PICE POLES

ELECTRIC STABILIZER
CONTROLS WITH
SMOOTH ALUMINUM DOOR

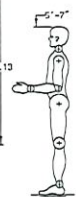

CHASSIS Enforcer Chassis ENGINE 525 HP Cummins X12 Engine	CAB 7010 Enforcer Cab BUMPER 15" Painted Aluminum	AXLE, FRONT, CUSTOM 24,000 lb T&E-4 Axle AXLE, REAR 52,000 lb Meritor Axle	TRANSMISSION Allison 5th Gen, 4000 EVS P	PUMPHOUSE 36" Control Zone Side Mount PUMP 2000 GPM Vortexus 5100	CROSSLAYS, 1.50" C2 1.50", Min Trugs, 200" CROSSLAYS, 2.50" 2.50", Crosslay Not Required	SPEEDLAYS Speedlays Not Required GENERATOR Generator Not Required	SAFETY Side Roll and Frontal Impact Protection	CUSTOMER APPROVAL APPROVED BY: _____ DATE: _____		JOB NO. — SCALE 1:24 DATE — DRAWN BY — CHECKED BY — SHEET SIZE D SHEET NO. 1 of 1
---	---	---	--	---	---	--	---	---	--	---

NOTE
1. SHELF/W/ RECEPTACLE WITH ORIGINAL SUPPLY WITH-EXIT LOCATED ON DRIVER SIDE OF THE CAB
2. AIR TALLE WITH SYSTEM/CT COUPLING IN THE DRIVER SIDE SIDEWALL
3. BATTERY CHARGER LOCATED PER ORDER
4. BATTERY CHARGE INDICATOR LOCATED ON THE DRIVER SIDE SEAT RISER
5. ADJUSTABLE SHELVES LOCATED PER ORDER
6. NON-PAINTED AERIAL HOUSING
7. 3-in-1 LAYERED BRACKETS AT AERIAL BASKET
DIMENSIONS SHOWN ARE APPROXIMATE AND ARE SUBJECT TO MINOR DEVIATIONS AS MAY OCCUR OR BE NECESSARY IN CONSTRUCTION. MINOR DETAILS NOT SHOWN.

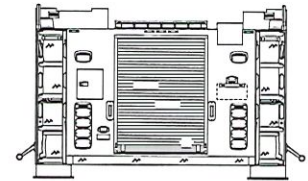
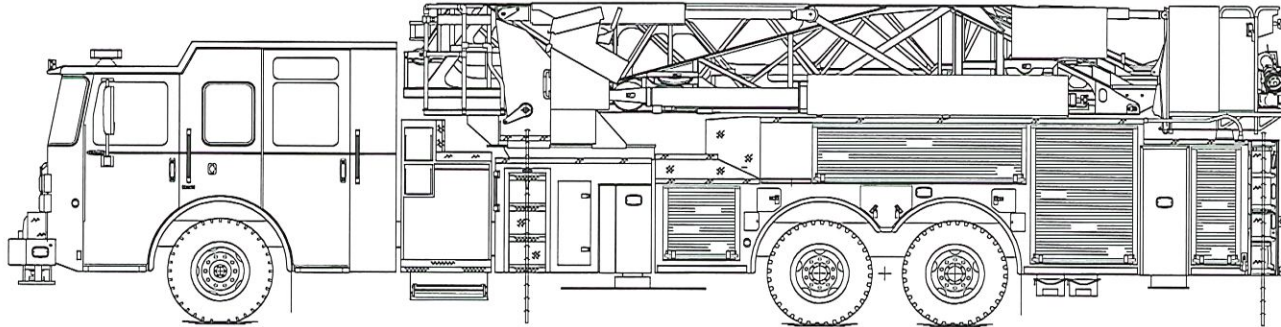
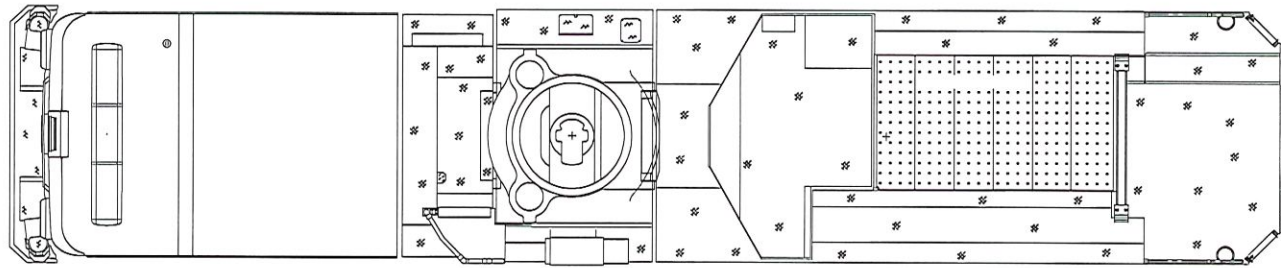
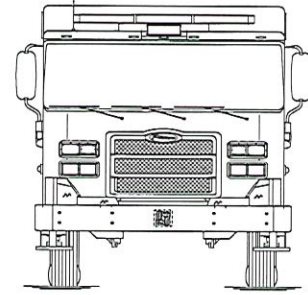
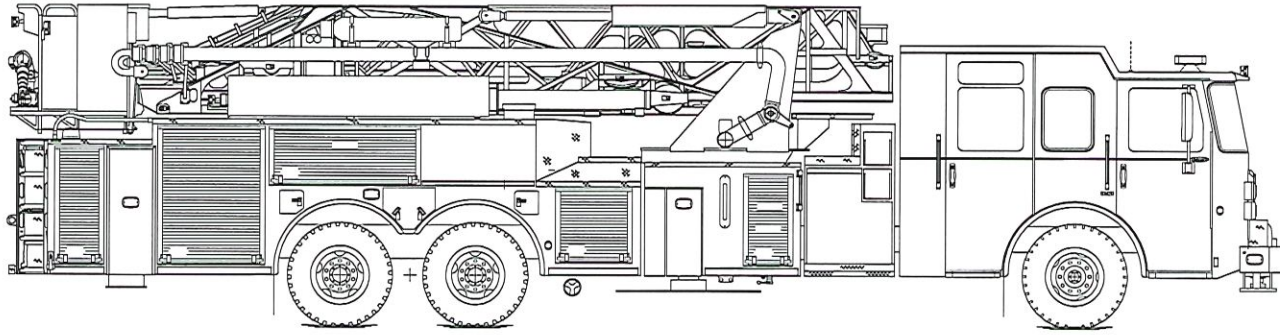

NOTE
LAYOUT AND SIZES PROVIDED BY CUSTOMERS
MAY VARY DUE TO AVAILABLE WORKING SPACE.

COLOR LEGEND	
PINK	LETTERING (VINYL OR REFLECTIVE)
ORANGE	STRIPING (VINYL OR REFLECTIVE)
GREEN	GOLD LEAF
YELLOW	CUSTOMER FURNISHED PRODUCT

CUSTOMER APPROVAL

APPROVED BY:
DATE:

REV	DATE	BY	CHK

CHASSIS DATA
MAKE
PIERCE
MODEL
DWC NO.

TITLE
LETTERING, STRIPING, AND PAINTING INSTRUCTIONS
FOR
Marshall AAT Tower
LSP-LP



JOB NO.	SCALE	DATE
-	1:24	

SHEET SIZE
D
SHEET NO.
1 of 1

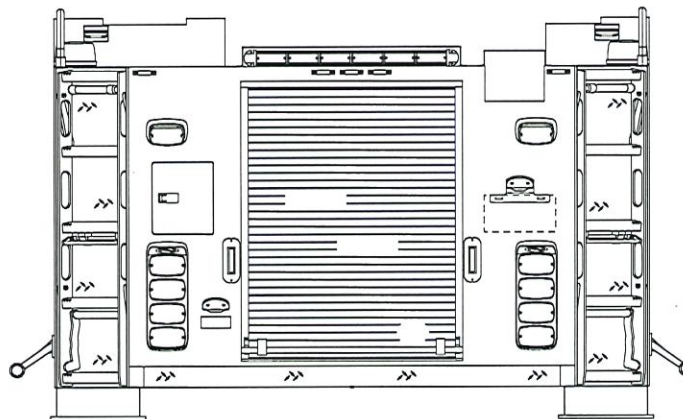

CUSTOMER APPROVAL

APPROVED BY: _____

DATE: _____

NOTE: PLEASE REVIEW CHEVRON COVERAGE AND DOOR MATERIAL PER PULSE OPTIONS. NON-RELATED OR NON-CRITICAL MINOR DEVIATIONS MAY EXIST.

 MANUFACTURING INC.		JOB NO.	-
		SCALE	1 : 24
TITLE	CHEVRON DRAWING -	DRAWN BY	-
FOR	Marshall AAT Tower -	DATE	06MAY22
DWG NO.	CHEVRON-CD	SHEET SIZE	SHEET NO.
		A	1 OF 1



PERFORM. LIKE NO OTHER.

MINNESOTA ILLINOIS INDIANA MISSOURI NEBRASKA NORTH DAKOTA SOUTH DAKOTA

EM-102

August 10, 2022

Assistant Chief Jake Olsen
City of Marshall Fire Department
201 East Saratoga Street
Marshall, MN 56258

Subject: **Proposal for one (1) Pierce Enforcer 100' Aerial Tower
Proposal / Bid 1072**

Dear Assistant Chief Olsen,

With regard to the above subject, please find attached our completed proposal.

Pricing, is as follows, including 100% prepay option.

Pricing Summary:

Sale Price – **\$1,813,107.00***
**Sourcewell Consortium Pricing, Member ID 2315.*

100% Performance Bond:

Included in the above price.

100% Prepayment Option:

Should the City of Marshall Fire Department elect to make a 100% prepayment at contract execution, a discount of (\$66,872.00) can be subtracted from the above "Sale Price" resulting in a revised contract price of **\$1,746,235.00**.

Terms and Conditions:

Taxes – Not Applicable
Freight – F.O.B. – Appleton, WI / Shipping to Marshall, MN
Terms – Net due prior to vehicle(s) release at the Pierce Manufacturing Plant (Appleton, WI). Net due at Contract signing for **Prepay discount** to be applicable.
Delivery – 27 - 31 months from receipt and acceptance of contract.



MINNESOTA ILLINOIS INDIANA MISSOURI NEBRASKA NORTH DAKOTA SOUTH DAKOTA

Said apparatus and equipment are to be built and shipped in accordance with the specifications hereto attached, delays due to strikes, war, or international conflicts, or other causes beyond our control not preventing, could alter the delivery schedule.

The specifications herein contained, shall form a part of the final contract, and are subject to changes as desired by the purchaser, provided such changes are acknowledged and agreed to in writing by the purchaser.

This proposal for fire apparatus conforms with all Federal Department of Transportation (DOT) rules and regulations in effect at the time of bid, and with all National Fire Protection Association (NFPA) Guidelines for Automotive Fire Apparatus as published at the time of bid, except as modified by customer specifications.

The attached proposal is valid for thirty (30) days.

We trust the above and the enclosed to be full and complete at this time; however, should you have any questions or require additional information, please do not hesitate to contact me at 507-272-2360 or tom.soland@macqueengroup.com.

We wish to thank the City of Marshall Fire Department for the opportunity to submit our proposal.

Respectfully,

Tom Soland

Tom Soland
Apparatus Sales
MacQueen Equipment LLC
DBA MacQueen Emergency Group

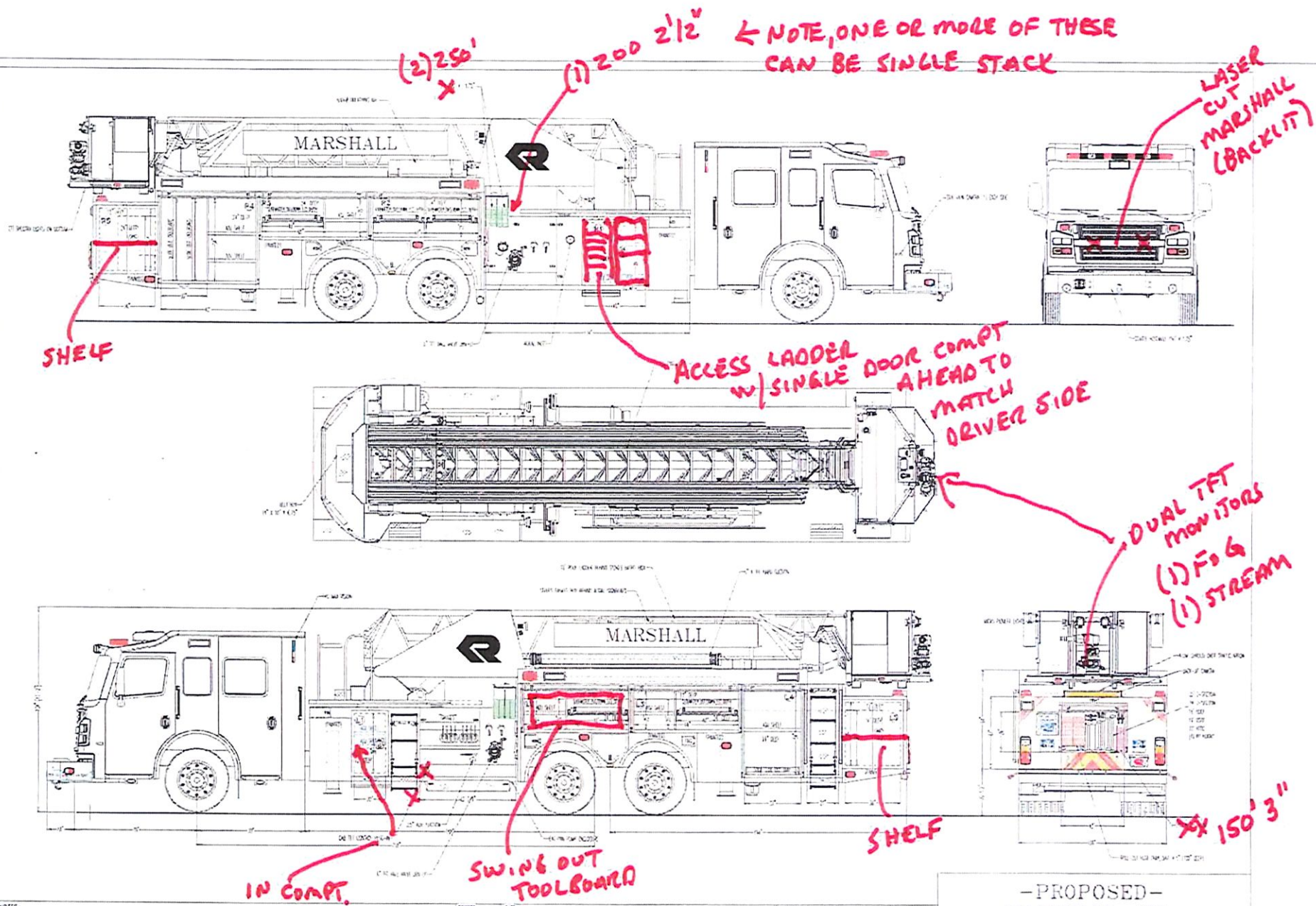

NOTES:
 1. OVERALL HEIGHT IS IN LOADED CONDITION. UNLOADED HEIGHTS MAY BE AT ABOVE HEIGHTS SHOWN.
 2. DO NOT SCALE DRAWING.
 3. ALL DIMENSIONS ARE APPROXIMATE AND SUBJECT TO ENGINEERING CHANGES.
 4. DRAWING MAY OR MAY NOT SHOW ALL ITEMS AS DESCRIBED IN THE WRITTEN DETAIL SPECIFICATIONS.
 5. INCLUSION OF AN ITEM ON THIS DRAWING DOES NOT CONSTITUTE INCLUSION OF THAT ITEM WITH THE FINAL DELIVERED UNIT.

REVISIONS:
 REVISION NO. DATE BY
 1. 10/10/10 JAW
 2. 10/10/10 JAW
 3. 10/10/10 JAW

PROPRIETARY AND CONFIDENTIAL
 THE INFORMATION CONTAINED IN THIS DRAWING IS THE SOLE PROPERTY OF ROSENBAUER. ANY REPRODUCTION IN PART OR AS A WHOLE WITHOUT THE WRITTEN PERMISSION OF ROSENBAUER IS PROHIBITED.

APPROVED BY	CHASSIS: ROSENBAUER R7011
MAXIMUM HEIGHT	NONE
MAXIMUM LENGTH	NONE
BODY WIDTH	100"
	PUMP: WATEROUS 5100 2300 GPM
	TANK: POLY 480 / 20 GAL
	TYPE: PUMPH
	AERIAL: 100' MIDMOUNT PLATFORM

-PROPOSED-
 MARSHALL, MN.

ROSENBAUER EXT
 PR511 01

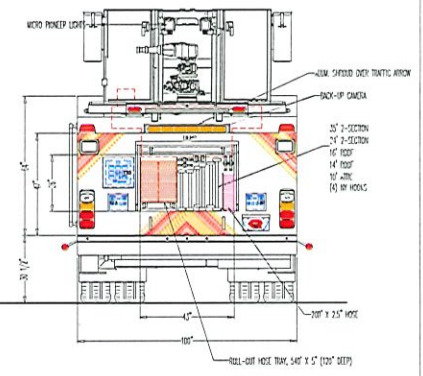
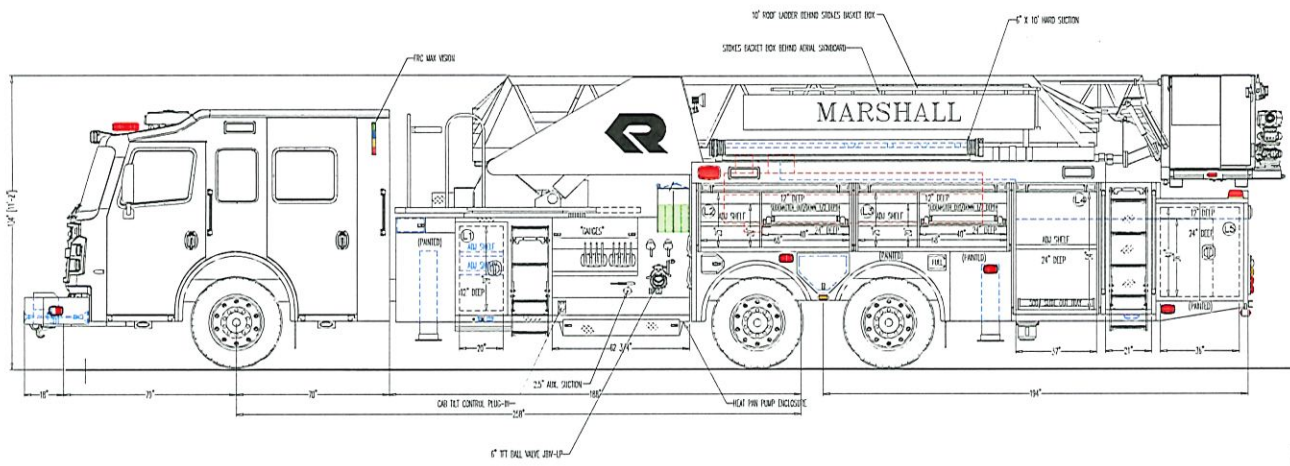
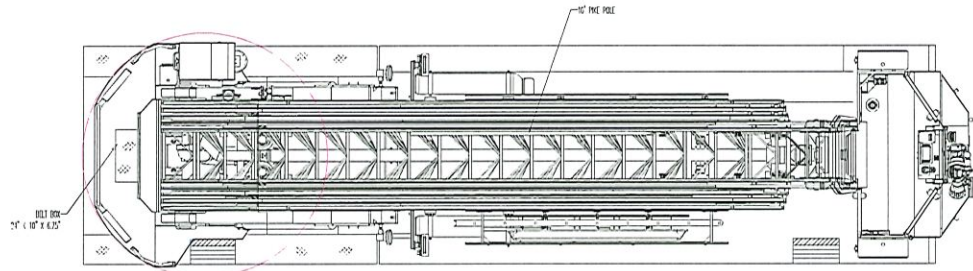
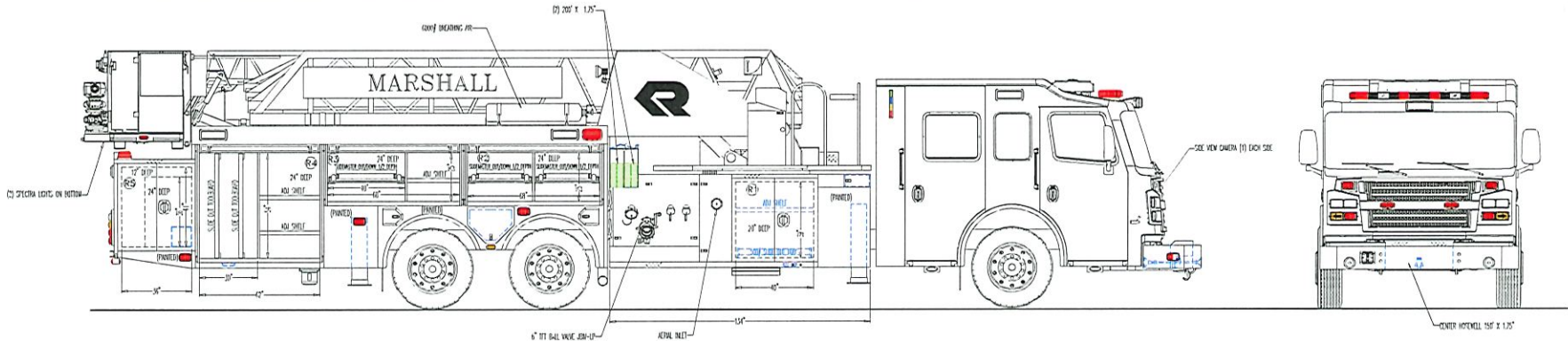

NOTES:
 1. OVERALL HEIGHT IS IN LOADED CONDITION. UNLOADED HEIGHTS MAY BE 4" ABOVE HEIGHTS SHOWN.
 2. DO NOT SCALE DRAWING.
 3. ALL DIMENSIONS ARE APPROXIMATE AND SUBJECT TO ENGINEERING CHANGES.
 4. DRAWING MAY OR MAY NOT SHOW ALL ITEMS AS DESCRIBED IN THE WRITTEN DETAIL SPECIFICATIONS.
 5. INCLUSION OF AN ITEM ON THE DRAWING DOES NOT CONSTITUTE INCLUSION OF THAT ITEM WITH THE FINAL DELIVERED UNIT.

REVISED: - DATE: -
 APPROVED: - DATE: -
 DRAWN: JMY DATE: 07-18-2022 (PST/CA-TZ)
 PROPRIETARY AND CONFIDENTIAL
 THE INFORMATION CONTAINED IN THIS DRAWING IS
 THE SOLE PROPERTY OF ROSENBAUER. ANY
 REPRODUCTION IN PART OR AS A WHOLE WITHOUT
 THE WRITTEN PERMISSION OF ROSENBAUER IS
 PROHIBITED.

APPROVED BY:

MAXIMUM HEIGHT	NONE
MAXIMUM LENGTH	NONE
BODY WIDTH	100"

CHASSIS: ROSENBAUER R7011
PUMP: WATEROUS S100 2000 GPM
TANK: POLY 480 / 20 GAL.
TYPE: PUMPER
AERIAL: 100' MIDMOUNT PL-TFORM

-PROPOSED-
 MARSHALL, MN.



ROSENBAUER EXT
 P8544 01



PURCHASE ORDER

Purchaser		SUPPLIER	
Purchaser:	City of Marshall	Contract #	FS12-19 For Years 2019-2023
Address 1:	344 West Main Street	Supplier:	Rosenbauer Minnesota, LLC
Address 2:		Address 1:	5180 260th Street
City, State, Zip:	Marshall, MN 56258	Address 2:	PO Box 549
		City, State, Zip:	Wyoming, MN 55092

Purchase Order Number:		Delivery in Calendar Days:	600
Date:	9/7/2022	HGAC Product Code	FS19YA08

The amount in this proposal shall remain firm for a period of 30 days from the date of same.

Quantity	Description	Price	Price (Extended)
1	One (1) Rosenbauer Aerial, complete with Rosenbauer Commander chassis and Rosenbauer Cobra Platform per attached specifications.	\$1,470,838.00	\$1,470,838.00
	Note: HGAC administration fee included in price		
*Note: If chassis amount of \$444,695.00 is paid upon arrival at our plant in Minnesota, deduct \$17,075.00 each			
*Note: If aerial amount of \$451,664.00 is paid upon arrival at our plant in Minnesota, deduct \$8,802.00 each			
TOTAL			\$1,470,838.00

NOTES:	
--------	--

Rosenbauer Dealer :	General Safety Fire Apparatus
Salesperson:	Steve Harris
Signature:	

Purchaser:	City of Marshall
Print Name:	
Title:	
Date:	
Signature:	



**APPENDIX C
CHANGE ORDER POLICY**

This change order policy is intended to reflect the increased cost of changes which result in delayed deliveries, confused paperwork, poor production flow and increased potential of trucks being built to incorrect specifications. With your cooperation, changes can be kept to a minimum which means we will be able to reduce lead times, increase production and maintain costs which will benefit all of us.

Our objective is accurate, high quality and on-time deliveries exceeding our customer expectations.

Changes any time after the order is received may delay the quoted delivery date. Significant design or component changes will have the largest impact on the schedule and quoted delivery date. Changes that occur later in the process will also have the largest impact on the schedule and quoted delivery date.

All time fences are reference to contract execution date if not otherwise stated.

Change Window #1

All changes will be priced at standard pricing and specials will be priced through our normal process. Significant changes made to the vehicle during this time period may result in a delivery extension.

RBM Chassis	0-60 days
RBA Aerial	0-60 days
Rosenbauer Body	0-60 days

Change Window #2

All changes are subject to a 25% mark-up, as well as a \$250.00 change order processing fee. All changes are subject to factory review and may be denied due to engineering or lead time issues.

RBM Chassis	61-75 days
RBA Aerial	61-75 days
Rosenbauer Body	61-120 days

Change Window #3

All changes are subject to a 50% mark-up, and 50% restocking fee on deleted items, as well as a \$250.00 change order processing fee. All changes are subject to factory review and may be denied due to engineering or lead time issues. No major components can be changed at this time; major components are considered engine, transmission, axles, suspension, cab, frame (wheelbase), seats, water pump and water tank.

RBM Chassis	76-120 days
RBA Aerial	76-120 days
Rosenbauer Body	121-180 days

Change Window #4

Changes are not recommended at this time. Any changes requested will be priced on a time and material basis, as well as a \$500.00 change order processing fee. Any changes requested, and that are quoted to the customer, must be approved by the customer within three days or they will not be valid.

RBM Chassis	After 120 days
RBA Aerial	After 120 days
Rosenbauer Body	After 180 days

**Note: Any late change orders that are factory driven will be done at cost and no additional mark up or penalties will apply.*

BUYER INITIALS: _____