

No delinquent taxes and transfer entered;
 Certificate of Real Estate Value
 () filed () not required

Certificate of Real Estate Value
 No.

 _____, 20____

 County Auditor

By _____
 Deputy

(reserved for recording data)

QUIT CLAIM DEED

Corporation or Partnership to Corporation or Partnership

STATE DEED TAX DUE HEREON: \$1.65

Dated: April 23, 2019

FOR VALUABLE CONSIDERATION, City of Marshall Housing and Redevelopment Authority, also known as Housing and Redevelopment Authority in and for the City of Marshall, Minnesota, a municipal corporation under the laws of the State of Minnesota, Grantor, hereby conveys and quitclaims to City of Marshall, Grantee, a municipal corporation under the laws of the State of Minnesota, real property in Lyon County, Minnesota, described as follows:

See attached surveys with land descriptions and easement descriptions.

Land descriptions are to be dedicated for public roadway and street use purposes forever. Utility easements are hereby donated and dedicated for public use forever.

together with all hereditaments and appurtenances belonging thereto.

The total consideration for this conveyance is \$500.00 or less.

Check box if applicable:

- The seller certifies that the seller does not know of any wells on the described real property.
- A well disclosure certificate accompanies this document.
- I am familiar with the property described in this instrument and I certify that the status and number of wells on the described real property have not changed since the last previously filed well disclosure certificate.

CITY OF MARSHALL HOUSING AND REDEVELOPMENT AUTHORITY ALSO KNOWN AS HOUSING AND REDEVELOPMENT AUTHORITY IN AND FOR THE CITY OF MARSHALL, MINNESOTA

Affix Deed Tax Stamp Here

By: _____
Robert J. Byrnes
Its: Chair

By: _____
Sharon Hanson
Its: Executive Director

STATE OF MINNESOTA)
)ss
COUNTY OF LYON)

The foregoing instrument was acknowledged before me this 23rd day of April, 2019, by Robert J. Byrnes and Sharon Hanson, the Chair and Executive Director of City of Marshall Housing and Redevelopment Authority, also known as Housing and Redevelopment Authority in and for the City of Marshall, Minnesota, a municipal corporation under the laws of the State of Minnesota, on behalf of the Authority.

NOTARIAL STAMP OR SEAL (OR OTHER TITLE OR RANK)

SIGNATURE OF PERSON TAKING ACKNOWLEDGMENT

Tax Statements for the real property described in this instrument should be sent to (Include name and address of Grantee):

City of Marshall
344 W. Main St.
Marshall, MN 56258

THIS INSTRUMENT WAS DRAFTED BY:

QUARNSTROM & DOERING, P.A.
By: Dennis H. Simpson
109 South Fourth Street
Marshall, MN 56258
(507) 537-1441

Certificate of Survey

A part of the Blocks 4 & 5, Commerce Park 2nd Addition
in the City of Marshall, Lyon County, Minnesota.

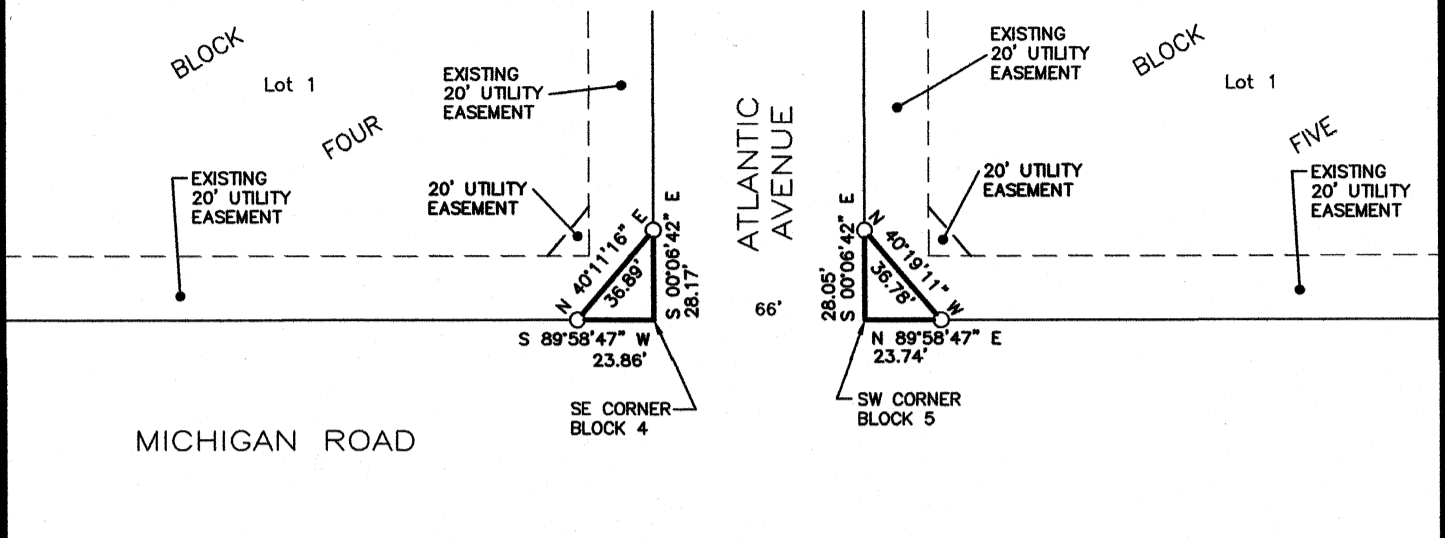

LAND DESCRIPTION IN BLOCK 4

All that part of Lot 1, Block 4 of Commerce Industrial Park Second Addition, in the City of Marshall, as filed and recorded in the office of the County Recorder in and for Lyon County, Minnesota, being more particularly described as follows:

Beginning at the southeast corner of said Block 4; thence South 89 degrees 58 minutes 47 seconds West, bearing based on Lyon County Coordinate System (1996 Adj.), along the south line of said Block 4, a distance of 23.86 feet; thence North 40 degrees 11 minutes 16 seconds East a distance of 36.89 feet, to a point on the east line of said Block 4; thence South 00 degrees 06 minutes 42 seconds East, along said east line a distance of 28.17 feet, to the point of beginning.

EASEMENT DESCRIPTION IN BLOCK 4

A 20 foot utility easement located in Lot 1, Block 4 of Commerce Industrial Park Second Addition, in the City of Marshall, as filed and recorded in the office of the County Recorder in and for Lyon County, Minnesota, lying northwesterly and adjacent to the following described line:

Commencing at the southeast corner of said Block 4; thence South 89 degrees 58 minutes 47 seconds West, bearing based on Lyon County Coordinate System (1996 Adj.), along the south line of said Block 4, a distance of 23.86 feet, to the point of beginning of said line to be described; thence North 40 degrees 11 minutes 16 seconds East a distance of 36.89 feet, to a point on the east line of said Block 4, said line there terminating.

LAND DESCRIPTION IN BLOCK 5

All that part of Lot 1, Block 5 of Commerce Industrial Park Second Addition, in the City of Marshall, as filed and recorded in the office of the County Recorder in and for Lyon County, Minnesota, being more particularly described as follows:

Beginning at the southwest corner of said Block 5; thence North 89 degrees 58 minutes 47 seconds East, bearing based on Lyon County Coordinate System (1996 Adj.), along the south line of said Block 5, a distance of 23.74 feet; thence North 40 degrees 19 minutes 11 seconds West a distance of 36.78 feet, to a point on the west line of said Block 5; thence South 00 degrees 06 minutes 42 seconds East, along said west line, a distance of 28.05 feet, to the point of beginning.

EASEMENT DESCRIPTION IN BLOCK 5

A 20 foot utility easement located in Lot 1, Block 5 of Commerce Industrial Park Second Addition, in the City of Marshall, as filed and recorded in the office of the County Recorder in and for Lyon County, Minnesota, lying northeasterly and adjacent to the following described line:

Commencing at the southwest corner of said Block 5; thence North 89 degrees 58 minutes 47 seconds East, bearing based on Lyon County Coordinate System (1996 Adj.), along the south line of said Block 5, a distance of 23.74 feet, to the point of beginning of said line to be described; thence North 40 degrees 19 minutes 11 seconds West a distance of 36.78 feet, to a point on the west line of said Block 5, said line there terminating.

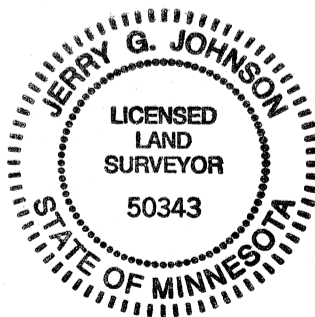

SURVEYOR'S CERTIFICATION

I hereby certify that this plan, specification, or report was prepared by me or under my direct supervision and that I am a duly Licensed Land Surveyor under the laws of the State of Minnesota.

[Signature]
JERRY G. JOHNSON LICENSE NO: 50343

DATE: APRIL 17, 2019

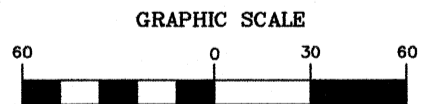

(IN FEET)
1 inch = 60 feet

LEGEND

These standard symbols will be found in the drawing.

- MONUMENTS FOUND
- MONUMENTS SET- 5/8" IRON W/SEAL #50343

Prepared for City of Marshall

Prepared by
Bueltel-Moseng Land Surveying, Inc.
Marshall, MN 56258 Ph. 507-532-9043
PROJECT NO. 18-2761A-1

Certificate of Survey

A part of the Blocks 5 & 6, Commerce Park 2nd Addition
in the City of Marshall, Lyon County, Minnesota.

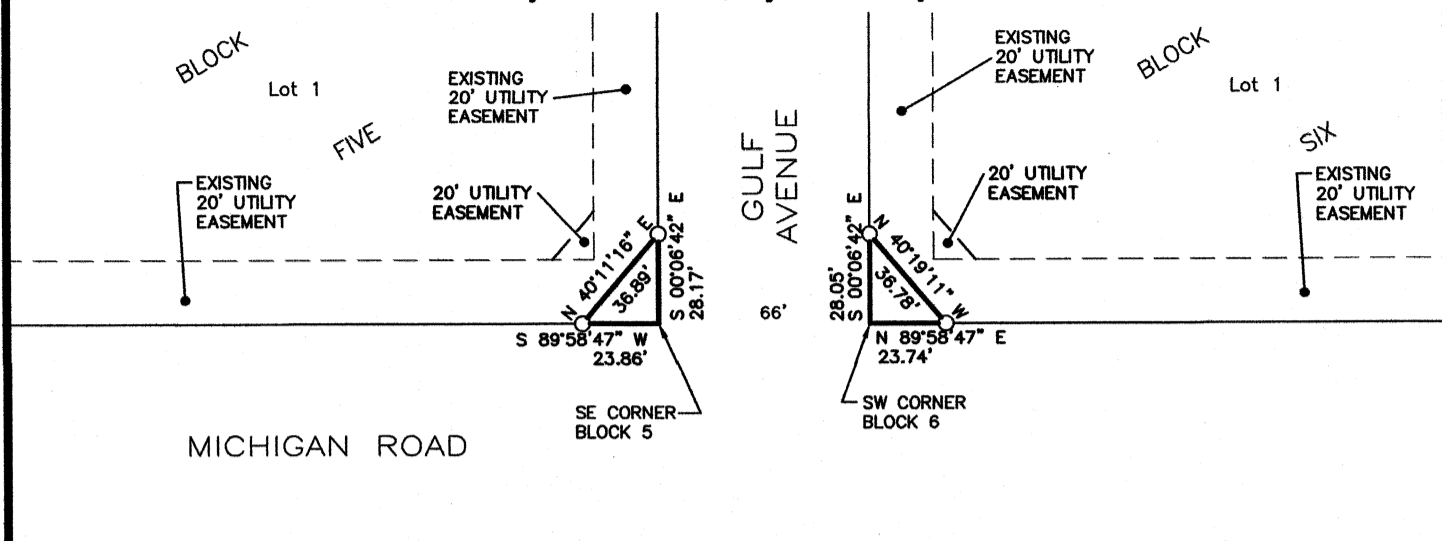

LAND DESCRIPTION IN BLOCK 5

All that part of Lot 1, Block 5 of Commerce Industrial Park Second Addition, in the City of Marshall, as filed and recorded in the office of the County Recorder in and for Lyon County, Minnesota, being more particularly described as follows:

Beginning at the southeast corner of said Block 5; thence South 89 degrees 58 minutes 47 seconds West, bearing based on Lyon County Coordinate System (1996 Adj.), along the south line of said Block 5, a distance of 23.86 feet; thence North 40 degrees 11 minutes 16 seconds East a distance of 36.89 feet, to a point on the east line of said Block 5; thence South 00 degrees 06 minutes 42 seconds East, along said east line a distance of 28.17 feet, to the point of beginning.

EASEMENT DESCRIPTION IN BLOCK 5

A 20 foot utility easement located in Lot 1, Block 5 of Commerce Industrial Park Second Addition, in the City of Marshall, as filed and recorded in the office of the County Recorder in and for Lyon County, Minnesota, lying northwesterly and adjacent to the following described line:

Commencing at the southeast corner of said Block 5; thence South 89 degrees 58 minutes 47 seconds West, bearing based on Lyon County Coordinate System (1996 Adj.), along the south line of said Block 5, a distance of 23.86 feet, to the point of beginning of said line to be described; thence North 40 degrees 11 minutes 16 seconds East a distance of 36.89 feet, to a point on the east line of said Block 5 said line there terminating.

LAND DESCRIPTION IN BLOCK 6

All that part of Lot 1, Block 6 of Commerce Industrial Park Second Addition, in the City of Marshall, as filed and recorded in the office of the County Recorder in and for Lyon County, Minnesota, being more particularly described as follows:

Beginning at the southwest corner of said Block 6; thence North 89 degrees 58 minutes 47 seconds East, bearing based on Lyon County Coordinate System (1996 Adj.), along the south line of said Block 6, a distance of 23.74 feet; thence North 40 degrees 19 minutes 11 seconds West a distance of 36.78 feet, to a point on the west line of said Block 6; thence South 00 degrees 06 minutes 42 seconds East, along said west line, a distance of 28.05 feet, to the point of beginning.

EASEMENT DESCRIPTION IN BLOCK 6

A 20 foot utility easement located in Lot 1, Block 6 of Commerce Industrial Park Second Addition, in the City of Marshall, as filed and recorded in the office of the County Recorder in and for Lyon County, Minnesota, lying northeasterly and adjacent to the following described line:

Commencing at the southwest corner of said Block 6; thence North 89 degrees 58 minutes 47 seconds East, bearing based on Lyon County Coordinate System (1996 Adj.), along the south line of said Block 6, a distance of 23.74 feet, to the point of beginning of said line to be described; thence North 40 degrees 19 minutes 11 seconds West a distance of 36.78 feet, to a point on the west line of said Block 6, said line there terminating.

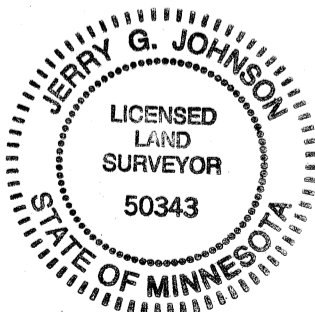

SURVEYOR'S CERTIFICATION

I hereby certify that this plan, specification, or report was prepared by me or under my direct supervision and that I am a duly Licensed Land Surveyor under the laws of the State of Minnesota.

[Signature]
JERRY G. JOHNSON LICENSE NO: 50343

DATE: APRIL 17, 2019

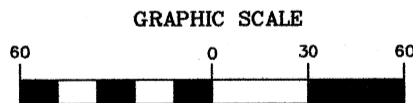

(IN FEET)
1 inch = 60 feet

LEGEND

These standard symbols will be found in the drawing.

- MONUMENTS FOUND
- MONUMENTS SET- 5/8" IRON W/SEAL #50343

Prepared for City of Marshall

Prepared by
Bueltel-Moseng Land Surveying, Inc.
Marshall, MN 56258 Ph. 507-532-9043
PROJECT NO. 18-2761A-2

Certificate of Survey

A part of Lot 1, Block 4, and Outlot E of Commerce Industrial Park 2nd Addition in the City of Marshall, Lyon County, Minnesota.

LAND DESCRIPTION IN BLOCK 4

All that part of Lot 1, Block 4 of Commerce Industrial Park Second Addition, in the City of Marshall, as filed and recorded in the office of the County Recorder in and for Lyon County, Minnesota, being more particularly described as follows:

Beginning at the southwest corner of said Block 4; thence North 89 degrees 58 minutes 47 seconds East, bearing based on Lyon County Coordinate System (1996 Adj.), along the south line of said Block 4, a distance of 21.69 feet; thence North 35 degrees 00 minutes 19 seconds West a distance of 37.47 feet, to a point on the west line of said Block 4; thence South 00 degrees 21 minutes 41 seconds West, along said west line, a distance of 30.70 feet, to the point of beginning.

EASEMENT DESCRIPTION IN BLOCK 4

A 20 foot utility easement located in Lot 1, Block 4 of Commerce Industrial Park Second Addition, in the City of Marshall, as filed and recorded in the office of the County Recorder in and for Lyon County, Minnesota, lying northeasterly and adjacent to the following described line:

Commencing at the southwest corner of said Block 4; thence North 89 degrees 58 minutes 47 seconds East, bearing based on Lyon County Coordinate System (1996 Adj.), along the south line of said Block 4, a distance of 21.69 feet, to the point of beginning of said line to be described; thence North 35 degrees 00 minutes 19 seconds West a distance of 37.47 feet, to a point on the west line of said Block 4, said line there terminating.

LAND DESCRIPTION IN OUTLOT E

All that part of Outlot E of Commerce Industrial Park Second Addition, in the City of Marshall, as filed and recorded in the office of the County Recorder in and for Lyon County, Minnesota, being more particularly described as follows:

Beginning at the northeast corner of said Outlot E; thence South 89 degrees 58 minutes 47 seconds West, bearing based on Lyon County Coordinate System (1996 Adj.), along the north line of said Outlot E, a distance of 43.32 feet, to a corner of said Outlot E; thence South 44 degrees 20 minutes 31 seconds West, along the northwest line of said Outlot E, a distance of 104.85 feet, to a corner of said Outlot E; thence South 00 degrees 39 minutes 29 seconds East, along the west line of said Outlot E, a distance of 150.74 feet, to a corner of said Outlot E; thence North 26 degrees 58 minutes 17 seconds East a distance of 253.28 feet, to the point of beginning.

EASEMENT DESCRIPTION IN OUTLOT E

A 20 foot utility easement located in Outlot E of Commerce Industrial Park Second Addition, in the City of Marshall, as filed and recorded in the office of the County Recorder in and for Lyon County, Minnesota, lying southeasterly and adjacent to the following described line:

Beginning at the northeast corner of said Outlot E; thence South 26 degrees 58 minutes 17 seconds West, bearing based on Lyon County Coordinate System (1996 Adj.), a distance of 253.28 feet, to a corner of said Outlot E, said line there terminating.

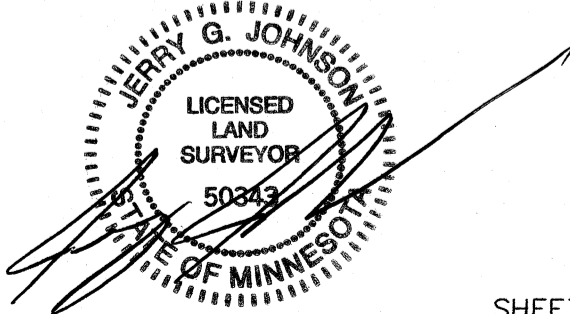

Prepared for City of Marshall

Prepared by
Bueltel-Moseng Land Surveying, Inc.
Marshall, MN 56258 Ph. 507-532-9043
PROJECT NO. 18-2761B