



**PLANNING AND ZONING COMMISSION
REGULAR SESSION MINUTES
JANUARY 10, 2024**

*This meeting was live streamed on Manor's YouTube Channel at
<https://www.youtube.com/@cityofmanorsocial/streams>*

PRESENT:

COMMISSIONERS:

Felix Paiz, Chair, Place 4
Prince Chavis, Vice Chair, Place 2
Julie Leonard, Place 1
Cresandra Hardeman, Place 3
Celestine Sermo, Place 5
Cecil Meyer, Place 6 (Absent)
Jim Terry, Place 7
Gabriel Nila, Alternate No. 1
Gabrielle Orion, Alternate No. 2

CITY STAFF:

Scott Dunlop, Development Services Director
Mandy Miller, Development Services Supervisor
Officer Vega
Emily Hill, Mayor Pro Tem
Aaron Moreno, City Council – Place 5
Scott Moore, City Manager

REGULAR SESSION: 6:30 P.M.

CALL TO ORDER AND ANNOUNCE A QUORUM IS PRESENT

With a quorum of the Planning and Zoning (P&Z) Commission present, the Regular Session of the Manor P&Z Commission was called to order by Vice Chair Paiz at 6:41 p.m. on Wednesday, January 10, 2024, in the Council Chambers of the Manor City Hall, 105 E. Eggleston St., Manor, Texas.

Vice Chair Paiz requested P&Z Commissioner Nila join the Commissioners on the dais in the position of Place 6.

PUBLIC COMMENTS

No one appeared to speak at this time.

At the request of Chair Paiz the following items, Public Hearing Item No. 3 and Regular Item No. 9, were pulled from the agenda and placed on the February 13, 2024, agenda.

- 3. Conduct a public hearing on a Subdivision Short Form Final Plat for the Junction Subdivision, two (2) lots on 9.2 acres, more or less, and being located at the intersection of La Grange St. and Murray Ave., Manor, TX. Applicant: BGE Inc. Owner: Junction Development, LLC.**
- 9. Consideration, discussion, and possible action on a Subdivision Short Form Final Plat for the Junction Subdivision, two (2) lots on 9.2 acres, more or less, and being located at the intersection of La Grange St. and Murray Ave., Manor, TX. Applicant: BGE Inc. Owner: Junction Development, LLC.**

REGULAR AGENDA

- 5. Consideration, discussion, and possible action to appoint a Planning and Zoning Commission Chairperson to serve a 1-year term.**

City Staff recommended that the P&Z Commission appoint a Planning and Zoning Commission Chairperson to serve a 1-year term.

Director Dunlop spoke regarding this item.

MOTION: Upon a motion made by Commissioner Chavis and seconded by Commissioner Leonard to appoint Commissioner Paiz as P&Z Commission Chair.

There was no further discussion.

Motion to Appoint Commissioner Paiz as Chair carried 7-0

- 6. Consideration, discussion, and possible action to appoint a Planning and Zoning Commission Vice-Chair to serve a 1-year term.**

City Staff recommended that the P&Z Commission appoint a Planning and Zoning Commission Vice-Chair to serve a 1-year term.

MOTION: Upon a motion made by Commissioner Leonard and seconded by Commissioner Nila to appoint Commissioner Chavis as P&Z Commission Vice-Chair.

There was no further discussion.

Motion to Appoint Commissioner Chavis as Vice Chair carried 7-0

PUBLIC HEARING

- 1. Conduct a public hearing on a Rezoning Application for the Dominion development, one (1) lot on 15.42 acres, more or less, and being located at 12200 Tower Rd, Manor, TX from (IN-1) Light Industrial to (MF-2) Multifamily – 25.** Applicant: Dominion.
Owner: Kenneth Tumlinson.

City Staff recommended that the P&Z Commission conduct a public hearing.

Chair Paiz opened the public hearing.

Mat Nugent with BKV Group, 222 2nd Street North, Minneapolis, Minnesota, submitted a speaker card in support of this item. Mr. Nugent did not wish to speak; however, he was available for any questions.

Neal Route with Dominion Inc., 4835 Lyndon B Johnson Fwy., Ste. 1000, Dallas, Texas, submitted a speaker card in support of this item. Mr. Route did not wish to speak; however, he was available for any questions.

David D'Amelio with Dominion Inc., 4835 Lyndon B Johnson Fwy., Ste. 1000, Dallas, Texas, presented handouts of the presentation and memos on the road and traffic type issues, drainage, and flooding type issues involved with the development. (*see attached documents*) Mr. D'Amelio gave the presentation and answered questions about the schools they have reached out to regarding this development.

Ben Green with Kimley-Horn & Associates, 10814 Jollyville Road Austin, Texas, stated he was the project engineer on this project. Mr. Green gave information about the traffic impact analysis (TIA). He addressed concerns regarding the current and future traffic issues in the area of this development.

Andrew Graham with Kimley-Horn & Associates, 10814 Jollyville Road Austin, Texas, gave additional information on the TIA and answered questions regarding the study details.

Mr. D'Amelio stated this property would be covered under Section 42. He explained the differences between Section 42 and Section 8 affordable housing.

Concerns were raised regarding the property safety of the residents. Commissioner Leonard suggested enclosed garages or a gate access in conjunction with the perimeter wall around the development.

Discussion was held regarding the stormwater runoff from the property.

Denice Martinez, 12,200 Tower Road, Manor, Texas, submitted a speaker card to speak in opposition of this item. She stated the address currently being used by the developer was her address and would like for this issue to be addressed by the developer. She expressed her concerns regarding the stormwater runoff, the larger culvert causing new flooding issues, the increase in traffic and roadway congestion.

Mr. D'Amelio answered additional questions regarding the property access points.

Additional discussion was held regarding the TIA and the property location. Mr. D'Amelio responded to questions about the thought process of choosing this property. He gave information on the TIA data collection and the organizations they have met with to gather information or feedback.

MOTION: Upon a motion made by Vice Chair Chavis and seconded by Commissioner Hardeman to close the public hear.

There was no further discussion.

Motion to Close carried 7-0

2. Conduct a public hearing on a Rezoning Application for Manor Commons Phase 3, one (1) lot on 0.98 acres, more or less, and being located at the northeast corner of US HWY 290 and FM 973, Manor, TX from (A) Agricultural to (C-1) Light Commercial.

Applicant: Greenview Development Corp. Owner: Timmerman Commercial Investments LP.

City Staff recommended that the P&Z Commission conduct a public hearing.

Chair Paiz opened the public hearing.

Director Dunlop gave information regarding the size, location, and zoning of the property. He responded to questions regarding the applicant and owner. He provided additional information regarding the reasons behind the rezoning request.

MOTION: Upon a motion made by Commissioner Hardeman and seconded by Commissioner Leonard to close the public hear.

There was no further discussion.

Motion to Close carried 7-0

PUBLIC COMMENTS

Robert Battaile, 502 E. Eggleston Street, Manor, Texas, submitted a speaker card to speak in opposition of Agenda Item No. 10. Mr. Battaile criticized the City of Manor and Police Department and the Developer handling of the development near the cemetery.

Barry Franklin with Gosey Group, LLC, 800 Lexington Street, Manor, Texas, submitted a speaker card to speak in support of Agenda Item #11. Mr. Franklin stated that his business specializes in end-of-life planning. He stated there were no plans to have services at this location.

Dwight Hill with Gosey Group LLC, 800 Lexington Street, Manor, Texas, submitted a speaker card to speak in support of Agenda Item #11. Mr. Hill stated they wanted to join the 5 (five) lots.

CONSENT AGENDA

4. Consideration, discussion, and possible action to approve the minutes of December 13, 2023, P&Z Commission Regular Meeting.

MOTION: Upon a motion made by Commissioner Leonard and seconded by Commissioner Nila to approve the consent agenda.

There was no further discussion.

Motion to Approve carried 7-0

REGULAR AGENDA

7. Consideration, discussion, and possible action on a Rezoning Application for the Dominion development, one (1) lot on 15.42 acres, more or less, and being located at 12200 Tower Rd, Manor, TX from (IN-1) Light Industrial to (MF-2) Multifamily – 25. Applicant: Dominion. Owner: Kenneth Tumlinson.

City Staff recommended that the P&Z Commission approve the Rezoning Application for the Dominion development, one (1) lot on 15.42 acres, more or less, and being located at 12200 Tower Rd, Manor, TX from (IN-1) Light Industrial to (MF-2) Multifamily – 25.

MOTION: Upon a motion made by Commissioner Sermo and seconded by Commissioner Hardeman to postpone this item to the February 13, 2024, P&Z Commission Meeting to allow time for the developer to provide additional information.

Discussion was held regarding the information that was being requested by the Commissioners.

Commissioner Sermo clarified that she would like additional information on the TIA, such as time frames and other details about the TIA data collection, and the property entrances.

Commissioner Leonard reiterated that she would like to see information regarding Fire's response to the planned access points.

Commissioner Hardeman stated that she would like to see more information on the property drainage, how the change would impact neighboring properties, and other options considered.

Commissioner Leonard stated she would like for the developer to meet with and get feedback from the Charter School.

Motion to Postpone carried 7-0

8. Consideration, discussion, and possible action on a Rezoning Application for Manor Commons Phase 3, one (1) lot on 0.98 acres, more or less, and being located at the northeast corner of US HWY 290 and FM 973, Manor, TX from (A) Agricultural to (C-1) Light Commercial. Applicant: Greenview Development Corp. Owner: Timmerman Commercial Investments LP.

City Staff recommended that the P&Z Commission approve the Rezoning Application for Manor Commons Phase 3, one (1) lot on 0.98 acres, more or less, and being located at the northeast corner of US HWY 290 and FM 973, Manor, TX from (A) Agricultural to (C-1) Light Commercial.

Discussion was held regarding the benefits of allowing the rezoning of this property.

Director Dunlop gave information about the surrounding properties that have already been rezoned.

MOTION: Upon a motion made by Commissioner Leonard and seconded by Commissioner Hardeman to approve the rezoning application for Manor Commons Phase 3, one (1) lot on 0.98 acres, more or less, and being located at the northeast corner of US HWY 290 and FM 973, Manor, TX from (A) Agricultural to (C-1) Light Commercial

There was no further discussion.

Motion to Approve carried 7-0

10. Consideration, discussion, and possible action on a Preliminary Plat for the New Haven Subdivision, two-hundred ninety-three (293) on 90.3 acres, more or less, and being located at Gregg Lane and FM 973, Manor, TX. Applicant: Gregg Lane Dev. LLC.
Owner: Quiddity.

City Staff recommended that the P&Z Commission approve the Preliminary Plat for the New Haven Subdivision, two-hundred ninety-three (293) on 90.3 acres, more or less, and being located at Gregg Lane and FM 973, Manor, TX subject to a final easement being approved by the city engineer.

John Alvarez with Quiddity Engineering, 3100 Alvin Devane Blvd., Suite 130, Austin, Texas, submitted a speaker card in support of this item. Mr. Alvaraz did not wish to speak; however, he was available for any questions.

Robert Battaile, 502 E. Eggleston Street, Manor, Texas, submitted a speaker card in opposition of this item.

Director Dunlop recapped the postponement of this item from the last meeting. He stated the additional information that was requested at the last meeting was provided in the backup information on this item. He stated the information included parks and amenities details as well as a copy of the PUD.

Discussion was held regarding the details of the prior postponement of this item which included concerns regarding the park locations for the development.

Mr. Alvarez answered questions regarding the park. He explained the availability for better environment for the amenities at that location due to topography.

Director Dunlop explained the necessary steps and potential downside to requiring the developer to move the park location. He stated there were easements still pending approval for this item; therefore, conditional approval is being sought.

MOTION: Upon a motion made by Commissioner Nila and seconded by Commissioner Leonard to approve the Preliminary Plat for the New Haven Subdivision, two-hundred ninety-three (293) on 90.3 acres, more or less, and being located at Gregg Lane and FM 973, Manor, TX, conditionally to the final easement being approved by the city engineer.

There was no further discussion.

Motion to Approve carried 7-0

11. Consideration, discussion, and possible action on a Joined Lot Affidavit for Lot 1-5, Block 12, Town of Manor, locally known as 800 N. Lexington Street, Manor, Texas. Applicant: Bobby Gosey. Owner: Bobby Gosey.

City Staff recommended that the P&Z Commission approve the Joining Lot Affidavit for Lot 1-5, Block 12, Town of Manor, Travis County, Texas.

Director Dunlop stated this item was postponed at the last meeting with the request to have the applicant or owner appear to address questions from the Commission. He reminded the Commission that those individuals spoke during the Public Comment section.

Director Dunlop spoke regarding the commonality of this type of request especially in the area of town where this property is located. He reviewed the join lot process.

Discussion was held and concerns were expressed regarding parking for this property.

Dwight Hill addressed concerns regarding parking. He stated the business would primarily be for administrative uses only therefore large amounts of parking would not be necessary for the business.

Director Dunlop clarified the parking requirement would be 13 (thirteen) to 19 (nineteen) parking spaces. Parking would be accessed at 1:150 for the designation of funeral services.

Barry Franklin stated only small services would have the option of on location services. Mr. Franklin stated most of the services would be held at Churches or other facilities that could accommodate larger crowds. He stated any embalming, receiving, dressing, and casketing would take place at the Taylor location. He stated the focus for the Manor location would be meetings, planning, preparation of services and pre-arrangements.

Mr. Hill stated prior businesses failed to meet city requirements, but they were trying to work with the city. He answered questions regarding any future remodeling or expansion plans for the property.

Director Dunlop replied to concerns for this type of development being aligned with the Comprehensive Plan. He responded to the non-compliance issues from past tenants.

Mr. Hill and Mr. Franklin answered questions regarding the business aspects, such as adjustments to doorways, hearse being onsite, and already prepared bodies in the building.

MOTION: Upon a motion made by Commissioner Nila and seconded by Vice Chair Chavis to approve the Joined Lot Affidavit for Lot 1-5, Block 12, Town of Manor, locally known as 800 N. Lexington Street, Manor, Texas.

There was no further discussion.

Motion to Adjourn carried 7-0

ADJOURNMENT

MOTION: Upon a motion made by Commissioner Leonard and seconded by Vice Chair Chavis to adjourn the regularly scheduled P&Z Commission meeting at 8:31 p.m. on Wednesday, January 10, 2024.

There was no further discussion.

Motion to Adjourn carried 7-0

These minutes were approved by the Planning and Zoning Commission on the 13th day of February 2024.

APPROVED:

Felix Paiz
Chairperson

ATTEST:

Mandy Miller
Development Services Supervisor



DOMINIUM

Tower Road Apartments
City Council Meeting

What we do hits **H O M E.**



DOMINIUM

About Us

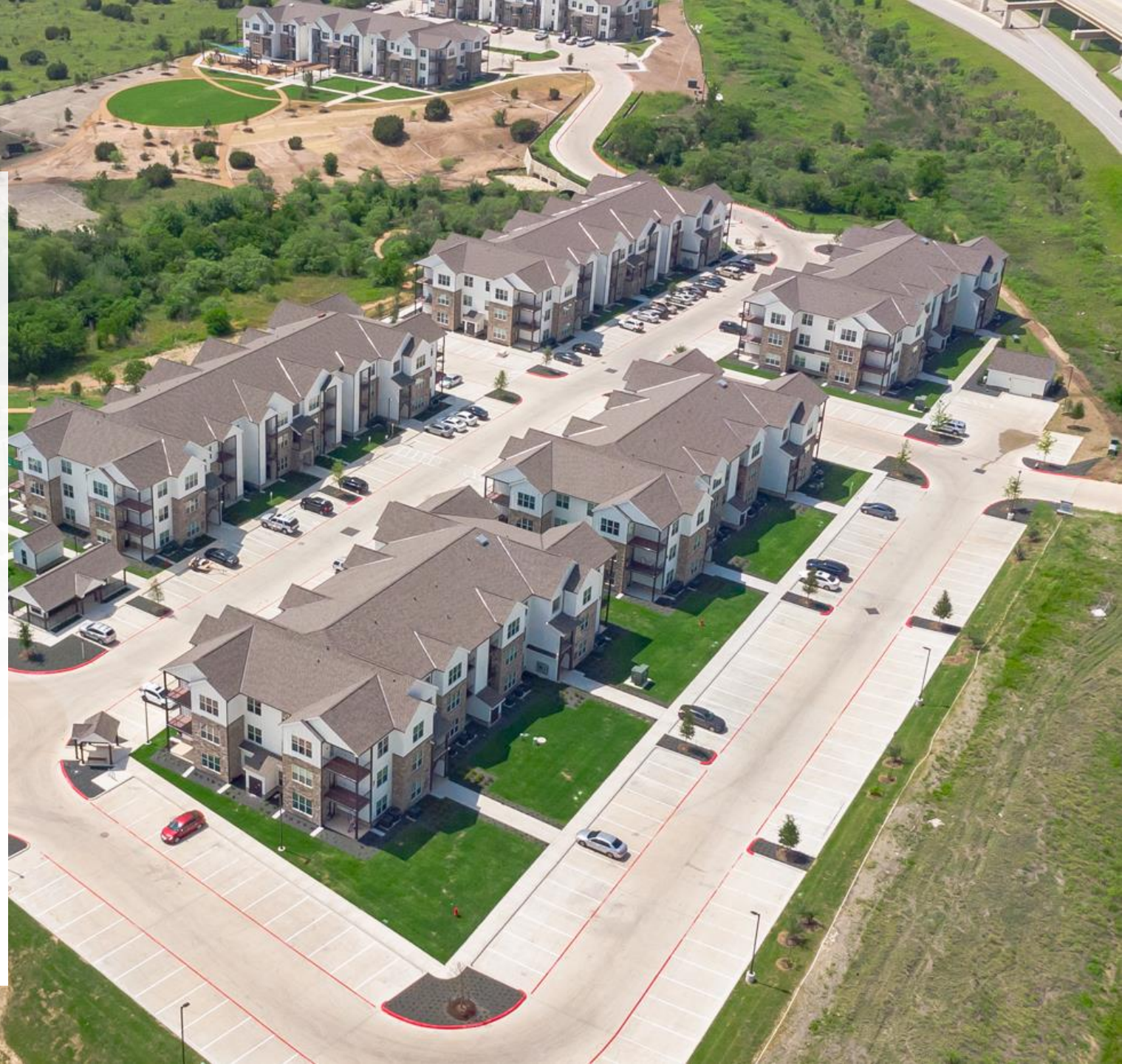

Dominium

Focused on results and long-term value

- Founded in 1972
- 2nd largest private developer of workforce housing
- Over 220 properties in portfolio nationwide
- Four regional offices, own properties in 19 states
- On track to become the country's pre-eminent developer, owner, and property manager of high-quality, workforce housing



*Crossroad Commons
Austin, TX*

FOOTPRINT BY STATE

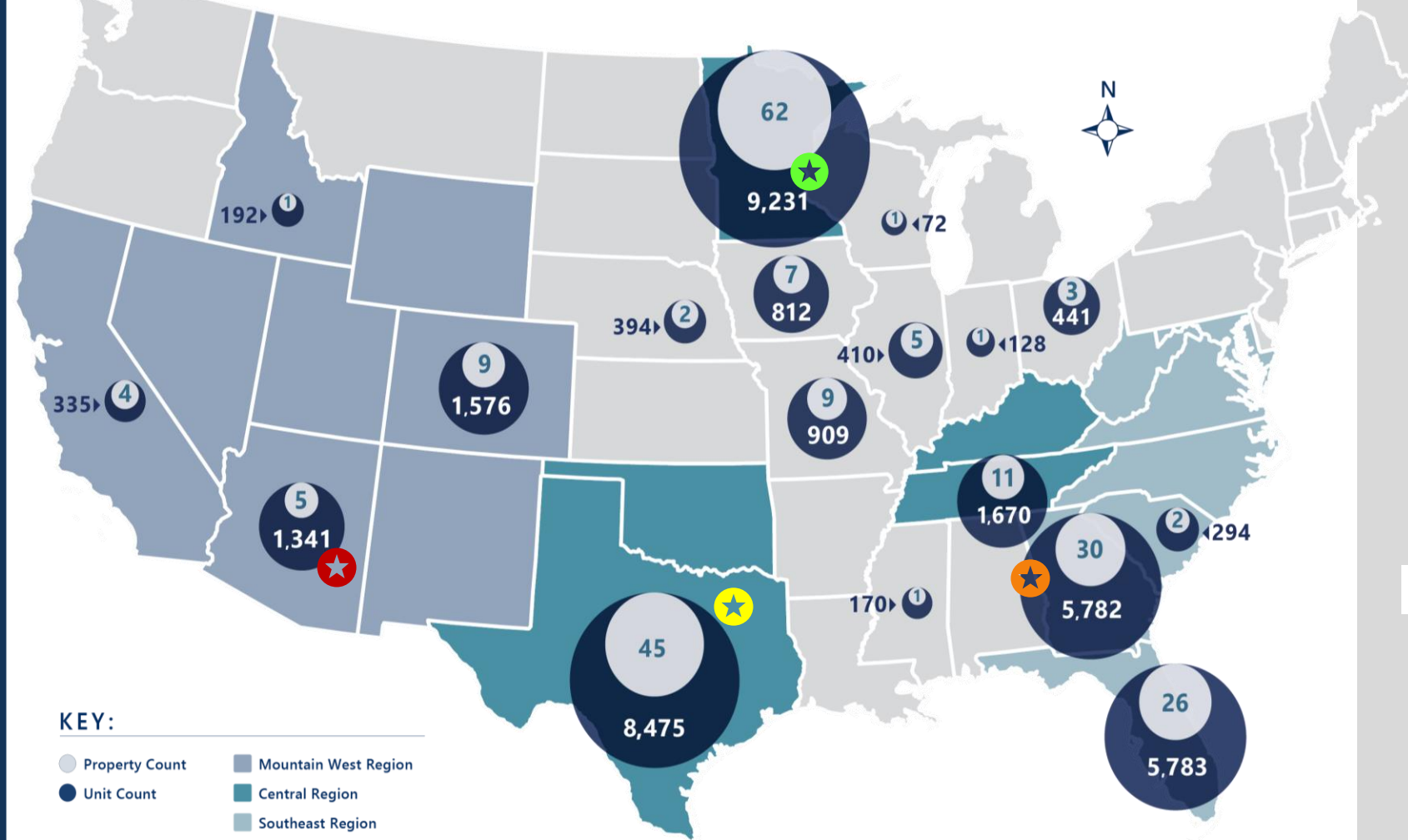

KEY:

- Property Count
- Unit Count
- Mountain West Region
- Central Region
- Southeast Region
- Not Assigned to a Region

*Data as of 04.2023

PORTFOLIO	SITES	UNITS
TOTAL	225	38,207

PROPERTIES OWNED FOR:

0-4 Years:	82	10-14 Years:	40
5-9 Years:	63	15+ Years:	40

Site: **838**

Corporate:

Property Management	122
Corporate Services/HR	170
Development/Construction	101

TOTAL	1,231
--------------	--------------

REGIONS	OFFICES	MSA GROWTH ¹
Southeast	Atlanta ² Tampa ³ Washington DC ³	5,409,115
Central	Dallas ² Minneapolis ²	3,785,341
Mountain West	Phoenix ² Denver ³	2,814,835

¹ Regional MSA growth 2010-2019 | ² Regional Headquarters Office | ³ Development Office

Giving Back to Our Communities

DOMINIUM GIVES

DONATES



DOMINIUM FOUNDATION

Direct donations to organizations that build stronger families and neighborhoods

Includes a Scholarship Program and Resident Internship Program

2019-2021: \$8.0mm

BUILDS

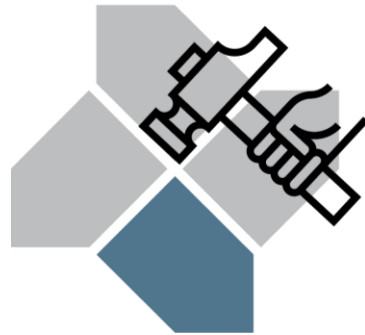

DOMINIUM PRO BONO PROGRAM

Free development services to nonprofit housing providers

To date, more than 2,500 workforce units across 13 developments worth over \$860mm

Closed or working on over 700 units designed to address U.S. homeless crisis

ASSISTS



DOMINIUM EMPLOYEE EMERGENCY FUND (EEF)

Employees donate to assist colleagues

Funds available for employees in need

Employee participation of more than 35%

Helping 86 families annually

VOLUNTEERS



DOMINIUM VOLUNTEER PROGRAM

Aligns company resources with employee passion

Dominium donates matching funds

750 Employees

30,000 Hours



DOMINIUM

Development
Overview



Manor Housing

- In February, City Council set the following housing goals:
 - Add an economic development tool
 - Building a community to support fixed wage-earning professionals
 - Address affordable housing initiatives
 - Build a collaborative public private partnership
 - Building a housing product that is needed in the community.
- Partnership with the City of Manor will allow Dominion to provide the residents of Manor with rents that are restricted and lower than the market rate average.



DOMINIUM



Milestones

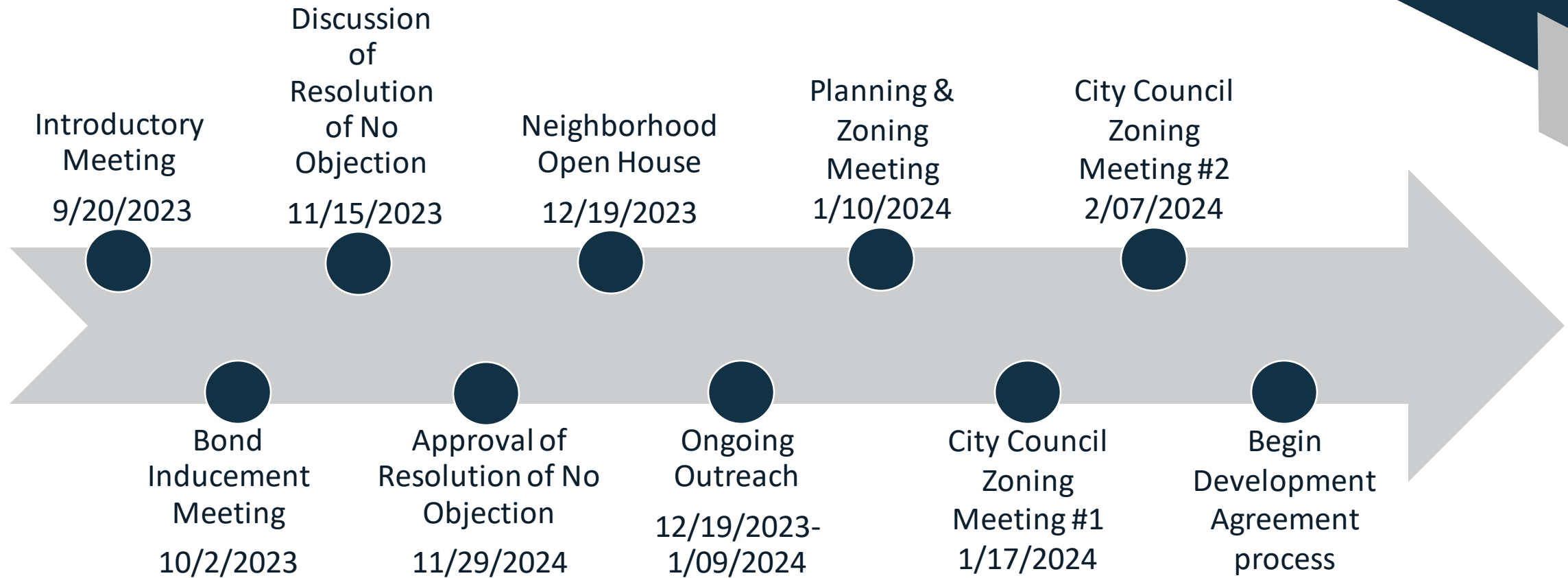

Location

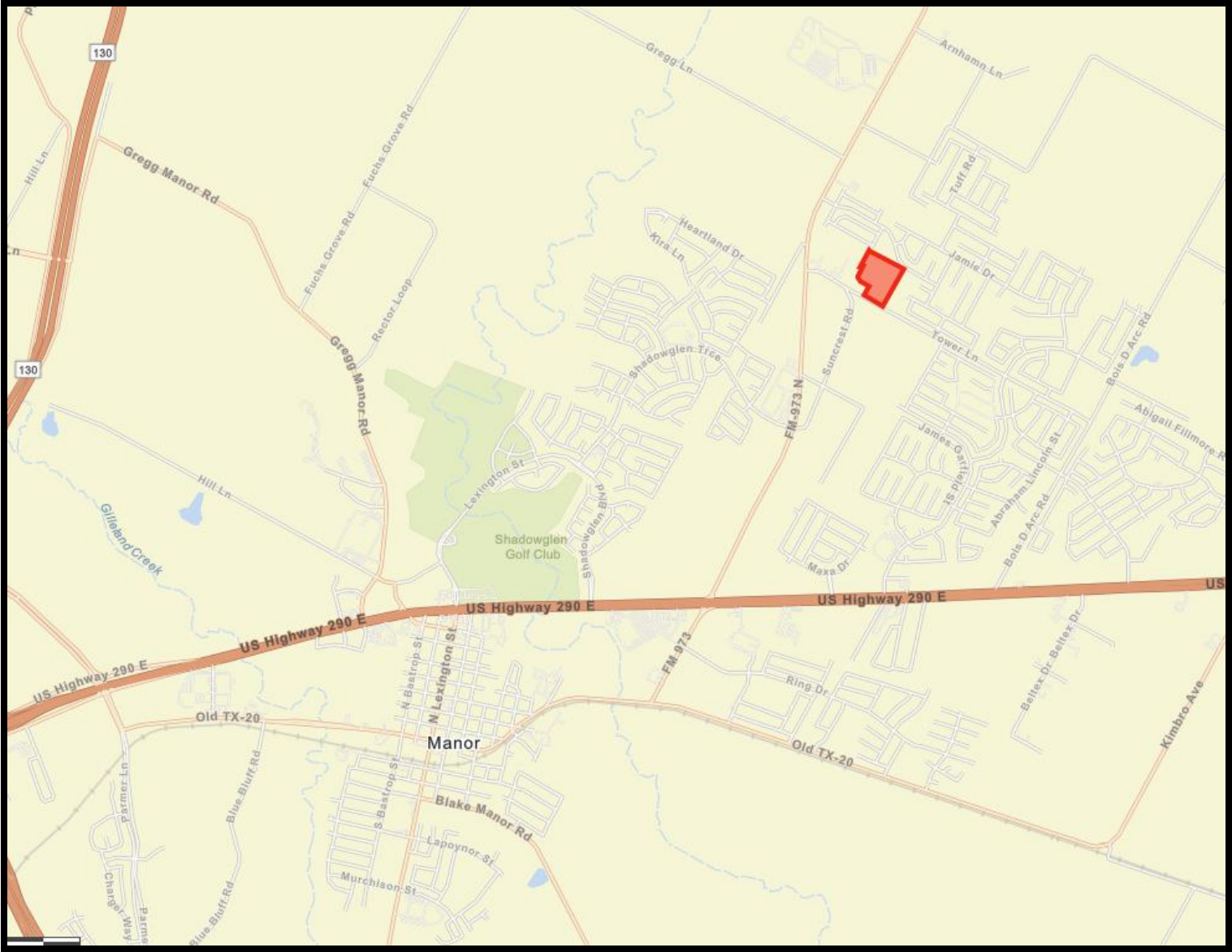

Unit Types & Restrictions

- Total of 324 units: 72 Two Bedroom, 186 Three Bedroom, 66 Four Bedroom
- 100% of the units will be income restricted to 60% Area Median Income through a 30-year period.
- Rents: \$1,512 – \$1,744 – \$1,940
- Income Limits Per Bedroom Type
 - 2 Person Income Limit – \$56,100
 - 3 Person Income Limit – \$63,120
 - 4 Person Income Limit – \$70,080



Concept Site Plan



Zoning

- The site is zoned for Industrial Use.
 - The proposed development will establish a buffer zone between the industrial and residential homes
 - Marketing efforts on the tract for other uses have proved unsuccessful
- Manor Comprehensive Plan – Mixed Density Neighborhoods
- Access Points will be off Tower Road.
- Ordered a traffic study to analyze traffic impact
- Fencing, landscaping, and screening requirements will be followed.









Comparable Community Rendering

Crossroad Commons – Austin, TX



Completed Community

Crossroad Commons – Austin, TX





DOMINIUM Development Amenities



Amenity Overview

In-Unit Amenities

- Private Balcony
- Full-size washer and dryer
- Gourmet Kitchens with full stainless steel appliance package
- Vinyl plank flooring, 9-foot ceilings, and walk-in closets

Community Amenities

- Clubhouse
- Picnic and grill areas
- Fitness center
- Business Center
- Professional on-site management
- Outdoor dining ramadas
- Outdoor game area
- Swimming Pool
- Playgrounds
- Resident Cafe
- Community Kitchen
- Learning Center



In-Unit Amenities



Community Amenities

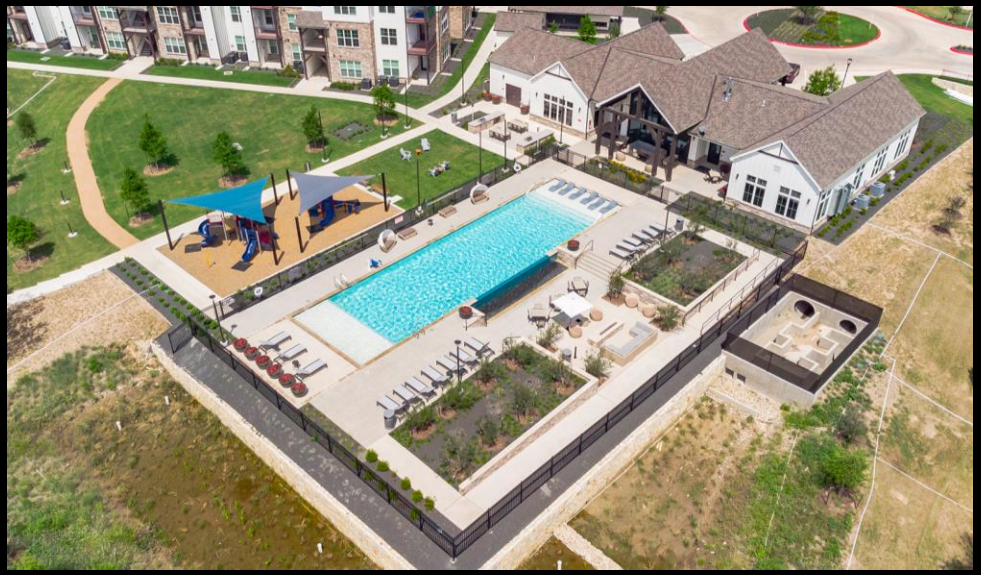

Resident Services

Resident services are provided in all Dominion communities. Below are the resident services we provide to our Crossroad Commons Community in Austin, TX.

- Annual income tax preparation (offered by an income tax prep service) or IRS-certified VITA (Volunteer Income Tax Assistance) program.
- Annual health fair provided by a health care professional.
- Twice monthly arts, crafts, and other recreational activities.
- Twice monthly on-site social events.
- Monthly food pantry.
- Quarterly events through partnerships with local law enforcement and first responders





DOMINIUM

Residents & Rent Savings



Daniela and Her Daughter
Enrollment Manager at
iKids U Central Texas

Annual Income: \$52,000

2-Person Income Limit: \$56,100

2-Bedroom Rent: \$1,512



Umar & Sarah K and Two Kids
Education Assistant at ShadowGlen
Elementary & Manor ISD Bus
Mechanic

Annual Income: \$67,154
4-Person Income Limit: \$70,080
4-Bedroom Rent: \$1,940



Housing as Economic Development

Building **100** affordable homes generates:

\$\$ \$11.7 million

in local income

161 local jobs

in the first year alone

\$2.2 million

in taxes and other revenues for local governments

Source: National Association of Home Builders

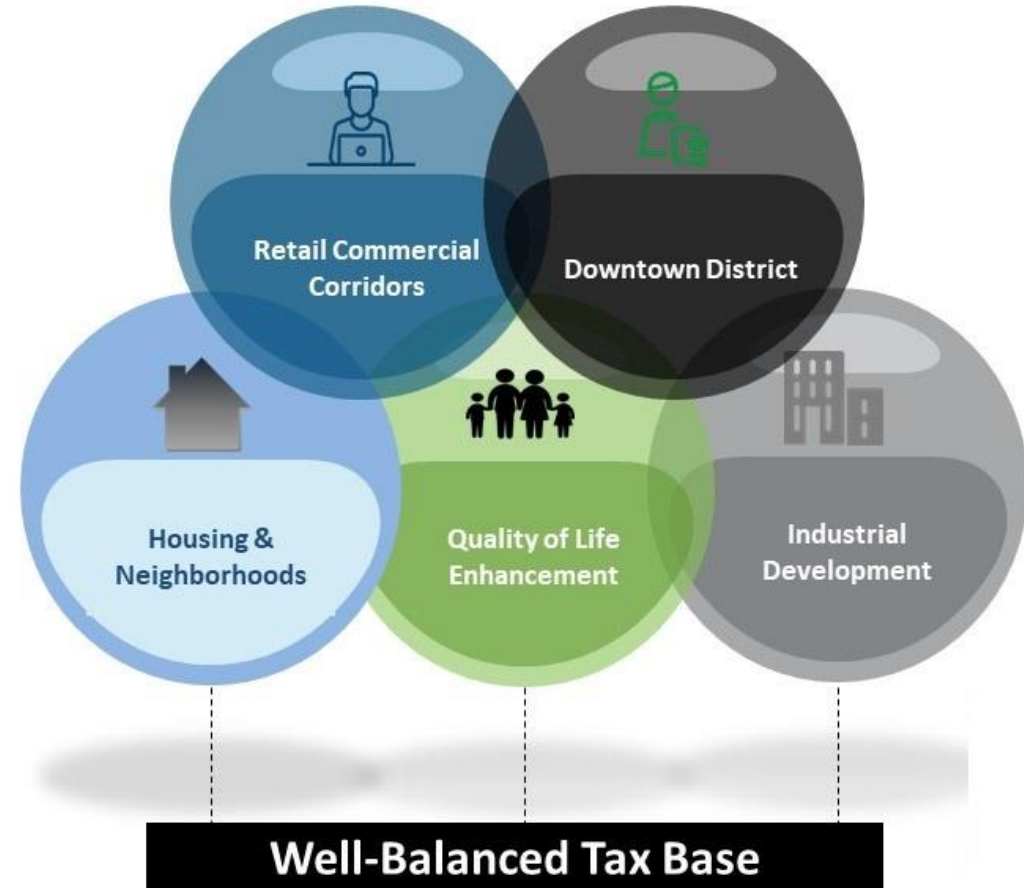

Annual Benefit

Two Bedroom Rent

- Our Rent – \$1,512
- Manor Market Rent – \$1,729
- Annual Resident Savings – \$2,604

Three Bedroom Rent

- Our Rent – \$1,744
- Manor Market Rent – \$2,135
- Annual Resident Savings – \$4,692

Four Bedroom Rent

- Our Rent – \$1,940
- Manor Market Rent – \$2,175
- Annual Resident Savings – \$2,820



15 Year Benefit

- **Two Bedroom**
 - Yearly Savings (Property Wide – 72 Units) - \$187,488
 - 3% Inflated Value Over 15 Years = \$3,440,764
- **Three Bedroom**
 - Yearly Savings (Property Wide – 186 Units) - \$872,712
 - 3% Inflated Value Over 15 Years = \$16,015,934
- **Four Bedroom**
 - Yearly Savings (Property Wide – 66 Units) - \$186,120
 - 3% Inflated Value Over 15 Years = \$3,415,658
- **Totals**
 - Yearly Savings (Property Wide – 324 Units) - \$1,246,320
 - 3% Inflated Value Over 15 Years = \$22,872,356





DOMINIUM

**Community
Outreach**





SAFE | stop abuse for everyone



Feedback

- Traffic
 - Adding center turn lane
 - Widening road
 - Relocating stop sign
 - Reconfiguring intersection
- Flooding
 - Currently there is a 24-inch pipe to convey water
 - Results in flooding in minor rainfall
 - Installation of four 3x6 box culverts
 - Two-year rain event will be kept under road
- Schools and Children
 - Addition of outdoor game area (ping pong, horseshoes)
 - Addition of after school learning center
 - Homework and tutoring services M-F, 15 hours / week
 - Partnership with ISD
 - Waiver of application fees
 - Pre-leasing event(s)

Thank You





David D'Amelio 

(214) 960-1309 

David.Amelio@dominiuminc.com 

Neal Route 

(214) 960-1162 

nroute@dominiuminc.com 

DominiumApartments.com 

Nicholas Koutani 

(214) 233-3104 

Nicholas.Koutani@dominiuminc.com 

PROPERTY PROFILE

OWNER: GOSEY BOBBY AND SHELDONG LIVING
 ADDRESS: 800 LEXINGTON ST , 78653
 LEGAL DESCRIPTION: LOT 1 - 5 BLK 12 LANE A E ADDITION
 ZONING: NB
 PROPERTY ID: 240911
 LAND: 33, 730.69 SQFT (0.7744 ACRES)

SCOPE OF WORK

- NEW FUNERAL HOME TENANT FINISHOUT , NO ADDITION TO STRUCTUR, NEW STANDARD AND ADA PARKING LOTS

BUILDING AREA	
Area	Name
1685 SF	1ST FLOOR
0 SF	Concrete Flatwork
115 SF	FRONT PORCH
471 SF	GARAGE
2272 SF	
2272 SF	

SHEET LIST			
SHEET NAME	SHEET #	DRAWN BY	APPROVED BY
TITLE PAGE	A0	Author	Approver
SITE PLAN	A101	Author	Approver
EROSION CONTROL PLAN	A102	Author	Approver
TREE PLAN	A103	Author	Approver
TREE PLAN CONT.	A104	Author	Approver
EXISTING / DEMO	A106	Author	Approver
NEW FLOOR PLAN	A106.1	Author	Approver
ACCESSIBILITY PLAN	A106.2	Author	Approver
EXISTING ELEVATIONS	A201	Author	Approver
EXISTING ELEVATIONS	A202	Author	Approver
NEW ELEVATIONS	A203	Author	Approver
NEW ELEVATIONS	A204	Author	Approver
SCHEDULE	A601	Author	Approver
ELECTRICAL	E1	Author	Approver
GENERAL NOTES	G1	Author	Approver
ADA NOTES	G2	Author	Approver

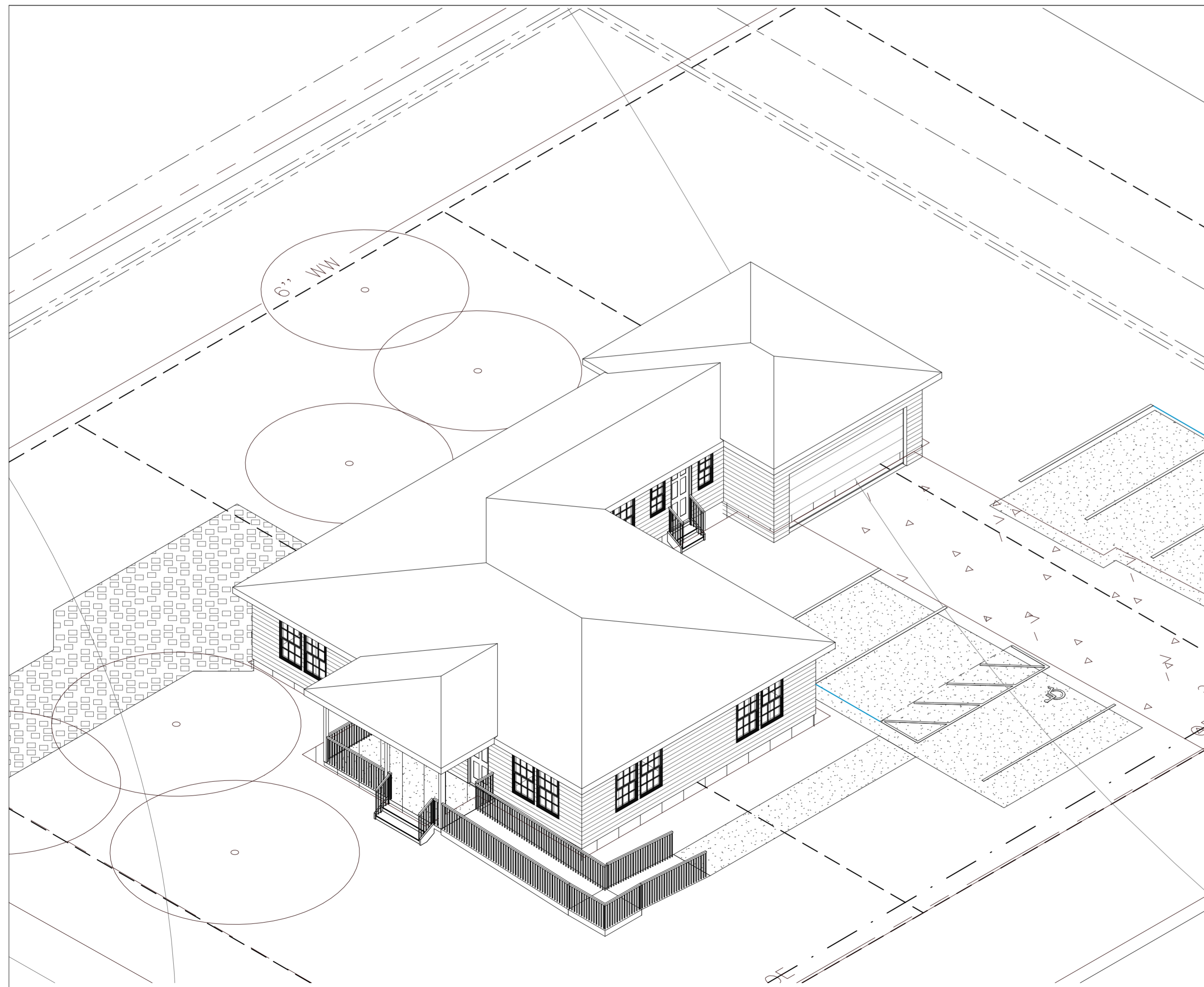

① FRONT AXON

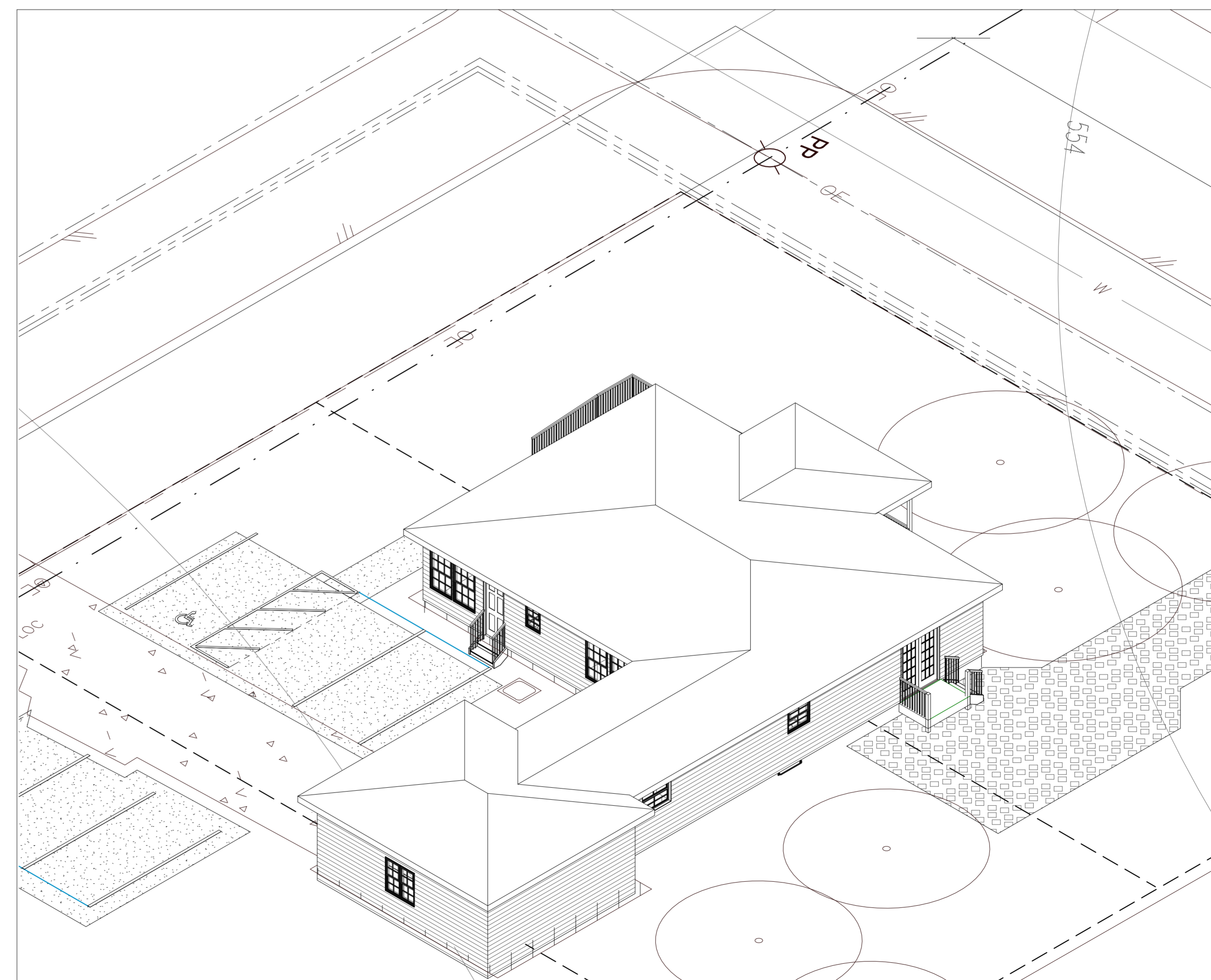

② BACK AXON

REV. #	DESC.	DATE

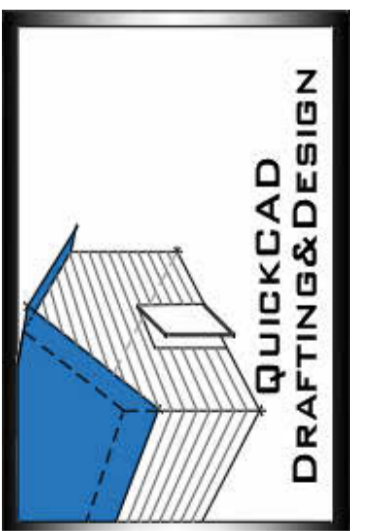

4926 Spicewood Springs RD
 Ste#105, Austin TX
 T: 512-822-5143
 Equickcaddesign@outlook.com

Project Number

DOOR & WINDOWS NOTES

1. ALL DOORS AND WINDOWS MUST COMPLY WITH CURRENT BUILDING CODES.
2. ALL INTERIOR DOORS 6'8 HOLLOW. UNLESS OTHERWISE NOTED.
3. EVERY BEDROOM SHALL BE PROVIDED WITH AN EGRESS WINDOW WITH A SILL FINISH HEIGHT NOT GREATER THAN 44" ABOVE THE FINISH FLOOR HEIGHT AND SHALL HAVE A MINIMUM OPEN AREA OF 5.7 SQFT.
4. EGRESS WINDOWS SHALL NOT HAVE AN OPERABLE AREA LESS THAN 20"WIDE OR 24" HIGH.
5. DOORS BETWEEN GARAGE AND LIVING AREA SHALL BE 1- 3/4" TIGHT FITTING SOLID CORE DOORS WITH A RATING OF 60 MINUTES. DOORS SHALL BE SELF CLOSING.
6. EXTERIOR EXIT DOORS WILL BE 36" MIN. NET CLEAR DOORWAY SHALL BE 32" MIN. DOORS SHALL BE OPERABLE FROM INSIDE WITH OUT THE USE OF A KEY OR ANY SPECIAL KNOWLEDGE OR EFFORT.
7. GLAZING IN DOORS SHALL BE DUAL PANE SAFETY GLASS.
8. THESE DOCUMENTS REFLECT NOMINAL WINDOW SIZES. WINDOW MANUFACTURER TO USE STANDARD SIZES UNLESS NOTED OTHERWISE

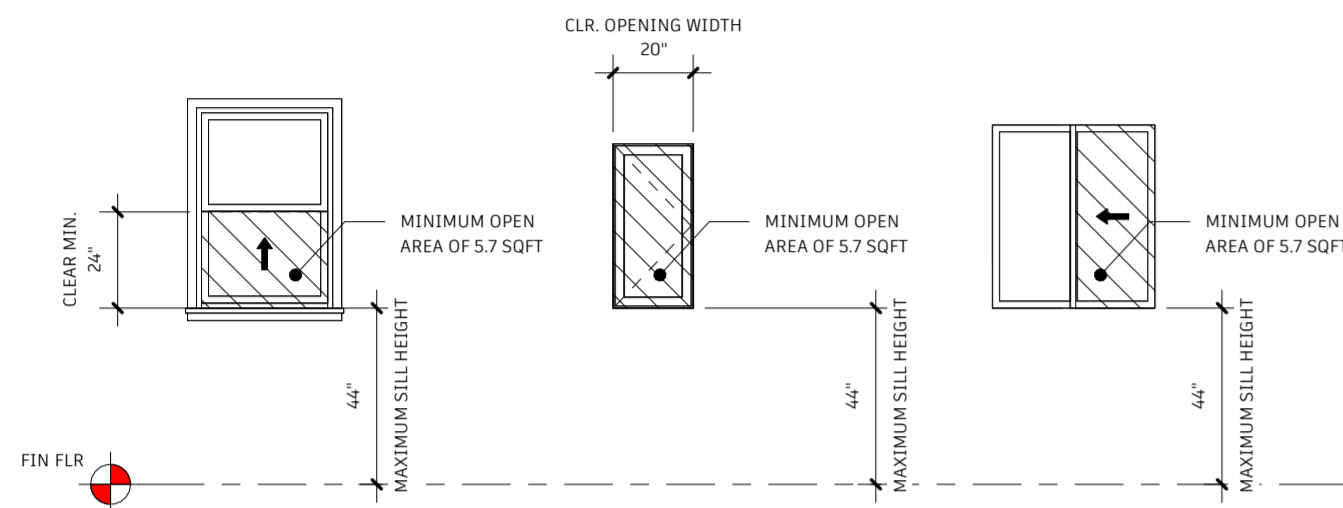

EGRESS WINDOW
1/4" = 1'-0"

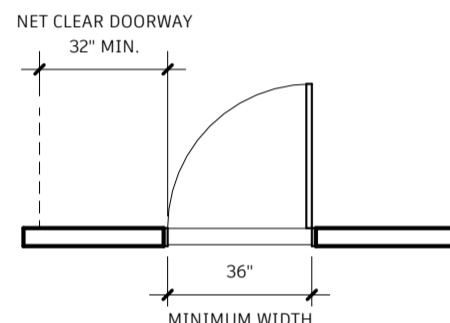

EGRESS DOOR
1/4" = 1'-0"

GLAZING/WINDOWS NOTES

1. GLAZING IN SIDE HINGED DOORS EXCEPT JALOUSIES.
2. GLAZING IN FIXED AND SLIDING PANELS OF SLIDING DOORS ASSEMBLIES AND PANELS IN SLIDING AND BIFOLD CLOSET DOORS ASSEMBLIES.
3. GLAZING IN STORM DOORS
4. GLAZING IN ALL UNFRAMED SWINGING DOORS.
5. GLAZING IN AN INDIVIDUAL FIXED OR OPERABLE PANEL, ADJACENT TO A DOOR WHERE THE NEAREST VERTICAL EDGE IS WITH-IN A 24 INCH ARC OF THE DOOR IN A CLOSED POSITION. AND WHOSE BOTTOM EDGE IS LESS THAN 60 INCHES FROM THE FLOOR OR WALKING SURFACE.
6. GLAZING IN AN INDIVIDUAL FIXED OR OPERABLE PANEL OTHER THAN THOSE LOCATIONS DESCRIBED ABOVE, THAT MEETS ALL THE FOLLOWING CONDITIONS.
 - EXPOSED ARE OF AN INDIVIDUAL PANE GREATER THAN 9 SQ FT.
 - TOP EDGE GREATER THAN 36" ABOVE FINISHED FLOOR.

ELECTRICAL NOTES

1. ALL INSTALLATION TO BE IN ACCORDANCE WITH LOCAL CODES AND THE NATIONAL ELECTRICAL CODE.
2. THE ELECTRICAL CONTRACTOR IS RESPONSIBLE FOR OBTAINING PERMITS AND INSPECTIONS.
3. CONVENIENCE OUTLETS TO BE MOUNTED AT 18" A.F.F MAX.
4. OUTLETS MOUNTED ABOVE CABINETS TO BE 6" ABOVE THE NOMINAL WORKING SURFACE AREA. SPECIALTY OUTLETS AS NOTED OR ACCORDING TO STANDARD PRACTICE.
5. REFRIGERATOR AND APPLIANCES OUTLETS SHALL BE AT 44" A.F.F
6. BATHROOM OUTLETS LABELED CT SHALL BE MOUNTED 6" ABOVE COUNTER.
7. SWITCH BOXES TO BE MOUNTED 42" MAX A.F.F TO CENTERLINE OF BOX CLUSTER.
8. MICROWAVE OUTLETS SHALL BE 20AMP. SEPARATE.
9. ATTIC LIGHT SWITCH BOX TO BE MOUNTED AT 84" A.F.F.
10. ATTIC LIGHTS SWITCH TO BE KEYLESS FIXTURE WITH INTEGRATED CONVENIENCE OUTLET LOCATED CONVENIENT TO ACCESS.
11. WASHER TO HAVE SEPARATE 20 AMP DUPLEX OUTLET AT 44" A.F.F
12. DRYER TO HAVE SEPARATE 220V 30AMP SINGLE OUTLET AT 44" A.F.F
13. ALL EXTERIOR OUTLETS TO BE GFCI AND WEATHERED PROTECTED.
14. TELEPHONE OUTLETS: PROVIDE BOX AT 14" A.F.F.FOR 6" ABOVE COUNTER.
15. CABLE OUTLETS: PROVIDE BOX AT 14" A.F.F OR 6" ABOVE COUNTER.
16. SMOKE ALARMS SHALL COMPLY W/NFPA72 & SECTION R314 OF THE INTERNATIONAL RESIDENTIAL CODE.

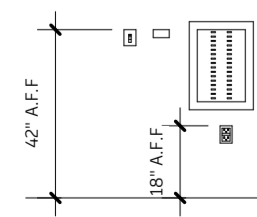

ELECTRICAL HEIGHT GUIDE
1/4" = 1'-0"

GENERAL CONTRACTOR NOTES

1. THESE PLANS ARE INTENDED TO PROVIDE THE BASIC CONSTRUCTION INFORMATION NECESSARY TO CONSTRUCT THIS STRUCTURE.THESE PLANS MUST BE FIELD VERIFIED AND CHECKED COMPLETELY BY THE GENERAL CONTRACTOR OR SUB-CONTRACTOR IN AUTHORITY FOR THE JOB. ANY DISCREPANCIES, ERROR, AND/OR OMISSION IF FOUND IS TO BE BROUGHT IMMEDIATELY TO THE ATTENTION OF THE DESIGNER PRIOR TO COMMENCING CONSTRUCTION,WORK, OF PURCHASE MADE.
2. ALL CODES, ORDINANCES, AND REQUIREMENTS FEDERAL, STATE, AND LOCAL, TAKE PRECEDENT OVER ANY PART OF THESE DOCUMENTS, WHICH MAY CONFLICT WITH THESE AGENCIES RULES AND OR REGULATIONS AND MUST BE ADHERED TO BEFORE AND DURING CONSTRUCTION.
3. ALL NOTES & DRAWINGS SHALL COMPLY WITH THE INTERNATIONAL RESIDENTIAL CODE FOR ONE AND TWO FAMILY DWELLINGS AS PRODUCED BY THE INTERNATIONAL CODE COUNCIL. ALL REFERENCES WERE/ARE TAKEN FORM THE 2021 ISSUE.
4. UNLESS OTHER WISE PERMITTED OR REQUIRED BY THE DRYER MFG, INSTALLATION INSTRUCTION OR APPROVED BY THE BLDG OFFICIAL DOMESTIC DRYER MOISTURE EXHAUST DUCTS SHALL NOT EXCEED A TOTAL COMBINED HORIZONTAL AND VERTICAL LENGTH OF A 14' INCLUDING TWO 90 D ELBOWS IN EXCESS OF TWO.
5. ATTIC ACCESS ARE PROVIDED ON PLANS TO SERVICES MECH. EQUIPMENT AND LIMITED LIGHT STORAGE BUT IN NO CASE SHALL THE COMBINED DECK ATTIC AREAS EXCEED 500 PSF.
6. SHOWER STALLS TO BE TILED FLOOR TO CEILING.
7. PROVIDE VENTILATION AT ALL BATHS AND UTILITY ROOM THROUGH NATURAL OR MECHANICAL MEANS AND COMPLY WITH R303.3 AND R303.4.
8. APPROVED SMOKE DETECTORS LOCATIONS SHALL COMPLY WITH SECTION R314.
9. IF AN ENGINEER STAMP/PLANS HAVE BEEN SUPPLIED BY OTHER AND ARE PRESENT. THE ENGINEER OF RECORD SHALL BEAR ALL STRUCTURAL RESPONSIBILITIES OF THE STRUCTURE CONTAINED HEREIN.
10. ALL ANGLES TO BE 45 D UNLESS NOTED OTHERWISE.
11. DIMENSIONS SHOWN ON THE FLOOR PLAN ARE NOMINAL, SLIGHT FIELD ADJUSTMENTS MAY BE NECESSARY TO ALLOW FOR ACTUAL MATERIAL SIZES AND PRACTICALITY OF THE CONVENTIONAL CONSTRUCTION METHODS. DETAILS AND NOTES NOT PROVIDED WITH THE DRAWINGS SHOULD BE PROVIDED BY THE MFG.
12. ALL AGREEMENTS AS OUT IN THE CONSTRUCTION AGREEMENT SHALL HOLD PRECEDENCE OVER ANY SPECIFICATIONS AS OUTLINED OR DEFINED IN THESE DRAWINGS.
13. INSULATE FOR SOUND AT ALL BATHS, MECH., AND LAUNDRY ROOM.
14. ANY WORK COMPLETED BY ANY SUBCONTRACTOR SHALL BE ONLY CONDUCTED UPON A WRITTEN AGREEMENT/CONTRACT BETWEEN THE BUILDER AND SAID SUBCONTRACTOR WITH THE FULL SCOPE OF WORK TO BE COMPLETED DULY NOTE IN THE PROPOSAL. IN ADDITION THE AGREEMENT/CONTRACT SHALL ALSO STATE EXACT COSTS TO BE INCURRED AND FULL DRAW AND PAYMENT INSTRUCTIONS/DEMANDS. NO SUBCONTRACT SHALL CHANGE ANY SPECIFICATION AS DEFINED BY THESE DRAWINGS WITHOUT THE WRITTEN CONSENT FROM BOTH THE OWNER AND BUILDER.
15. BUILDER SHALL NOTE THE FOLLOWING SPECIFIC CONSTRUCTION GUIDELINES IN ADDITION TO THE GENERAL NOTES SUPPLIED IN THESE DRAWINGS.

- ALL WINDOWS SHALL BE APPROVED LOW E GLASS
- FURNACES INSTALLED SHALL MEET A MINIMUM OF AN 80% AFUE RATING
- ALL AIR CONDITIONING SYSTEMS SHALL BE A MINIMUM OF 12 SEER UNITS AS PER 2021 INTERNATIONAL ENERGY CONSERVATION CODE IECC.
- MECHANICAL DUCTING REFER TO 2021 IECC REQUIREMENTS.
- ALL EXTERIOR WALLS SHALL BE A MINIMUM OR R-13 INSULATION.
- ALL CLOSED DOOR ROOMS SHALL RECEIVED A RETURNED AIR GRILL FOR PROPER AIR CIRCULATION.

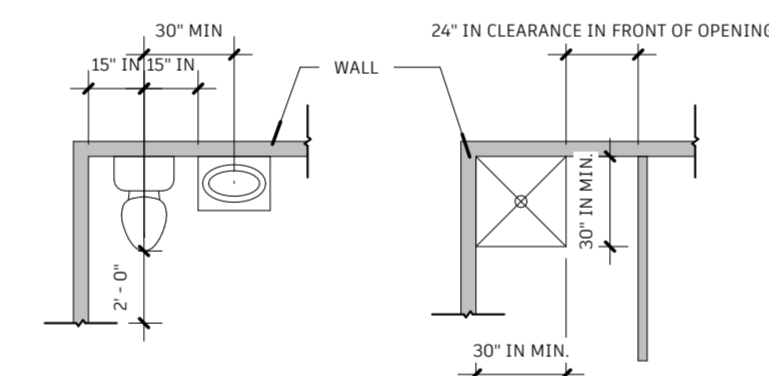

TOILET AND SHOWER MIN CLEARANCES
PER IRC
3/16" = 1'-0"

2017 NEC GFCI REQUIREMENTS FOR DWELLING UNITS

ARTICLE 210.8 STATES THAT GROUND FAULT INTERRUPTERS SHALL BE USED FOR ALL 125 VOLT SINGLE PHASE 15 AND 20 AMP RECEPTACLES IN THE FOLLOWING LOCATIONS.

- BATHROOM: ALL RECEPTACLES
- EXCEPTIONS: RECEPTACLES SUPPLYING ONLY PERMANENTLY INSTALLED FIRE ALARM OR BURGLAR ALARM SYSTEM, RECEPTACLES THAT ARE NOT READILY ACCESSIBLE, RECEPTACLES ON A DEDICATED CIRCUIT AND LABELED FOR USED WITH A PLUG-IN EQUIPMENT.
- KITCHENS: ALL RECEPTACLES SERVING COUNTERTOP AREAS AND ANY RECEPTACLE WITHIN 4 FEET OF A SINK.
- LAUNDRY, UTILITY, AND WET BARS: WHERE RECEPTACLES ARE PLACED WITHIN SIX FEET OF THE OUTSIDE EDGE OF THE SINK.

CODES TO FOLLOW

- INTERNATIONAL BUILDING CODE 2021
- INTERNATIONAL RESIDENTIAL CODE 2021
- INTERNATIONAL ENERGY CONSERVATION CODE 2021
- INTERNATIONAL FIRE CODE 2021
- UNIFORM MECHANICAL CODE 2021
- UNIFORM PLUMBING CODE 2021
- NATIONAL ELECTRICAL CODE 2020
- AMERICAN NATIONAL STANDARD ACCESSIBLE & USABLE

ABBREVIATIONS

ABV	ABOVE FINISHED FLOOR
AFG	ABOVE FINISHED GRADE
A/C	AIR CONDITIONED UNIT
AB	ANCHOR BOLT
BR	BEDROOM
CAB	CABINET
CLG	CEILING
CSMT	CASEMENT
CLO	CLOSET
CL D	CLOTHES DRYER
CONC FLOOR	CONCRETE FLOOR
CNTR	COUNTER
DW	DISHWASHER
DWH	DOMESTIC WATER HEATER
DS	DOWNSPOUT
ESMT	EASEMENT
EXST GR	EXISTING GRADE
EF	EXTERIOR FINISH
FOS	FACE OF STUD
FOW	FACE OF WALL
FIN	FNISH
FF EL	FINISH FLOOR ELEVATION
FIN GR	FINISH GRADE
GA	GAUGE
GYP BD	GYPSUM BOARD
HC	HOLLOW CORE
HB	HOSE BIB
INSUL	INSULATION
LAU	LAUNDRY
MTL	METAL



BROWN FUNERAL HOUSE
800 Lexington St, Manor TX



4926 Spicewood Springs RD
Ste#105, Austin TX

T: 512-822-5143
E: quickcaddesign@outlook.com

As indicated

Project Number

G1

GENERAL NOTES

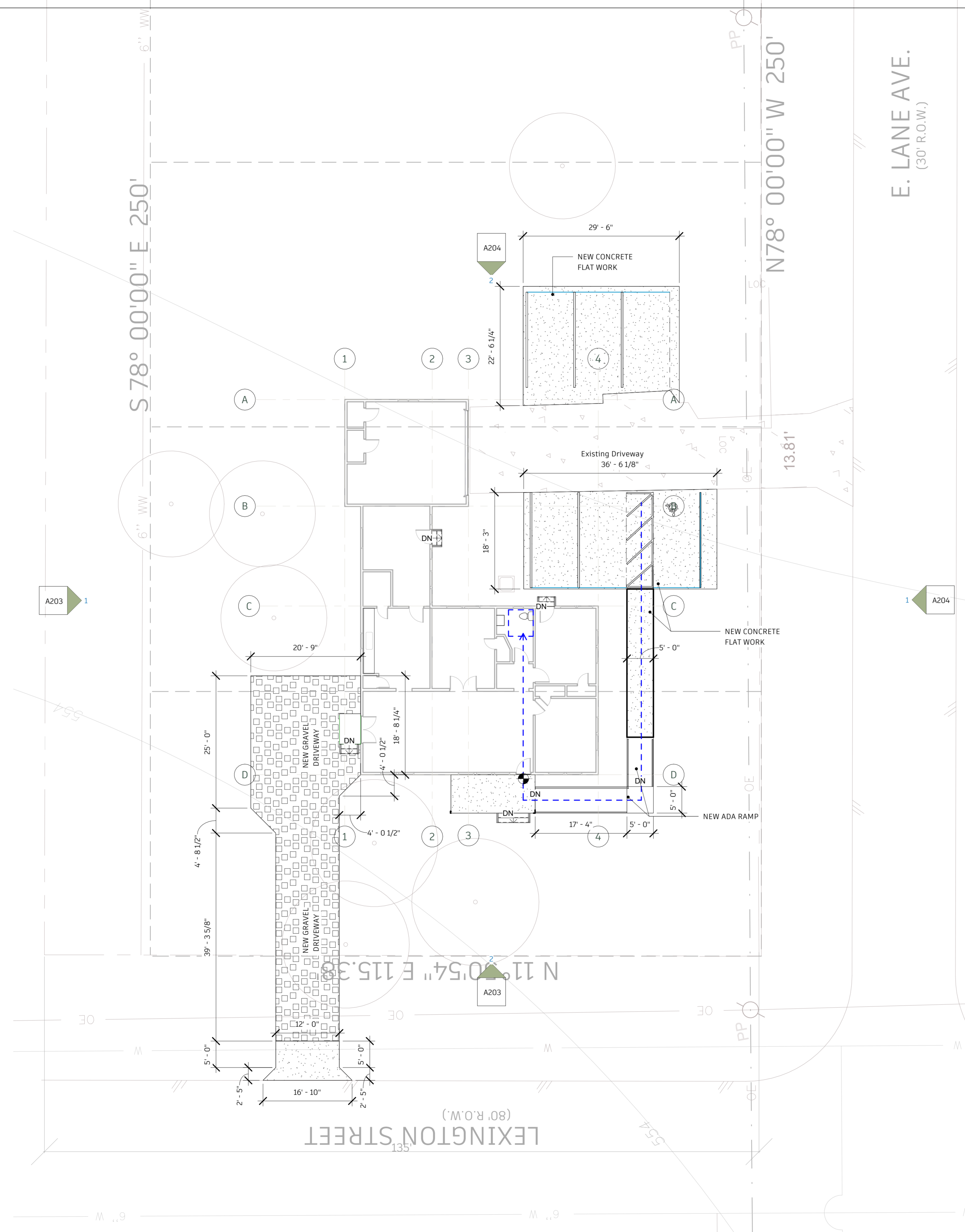

GENERAL SITE PLAN NOTES

- BUILDER TO RESCULPTURE TOPO/FINISHED GRADE TO PROVIDE PROPER DRAINAGE OF SURFACE WATER AWAY FROM BUILDING AS REQ'D.
- BUILDER TO CONFIRM FINAL LOCATION OF PROPOSED RESIDENCE
- UTILITY LINES DRAWN ON PLAN FOR REPRESENTATIONAL PURPOSES ONLY.GENERAL CONTRACTOR TO FIELD VERIFY UTILITY LINE LOCATIONS.
- EXPOSED FOUNDATION TO BE A MINIMUM OF 8" AND A MAXIMUM OF 24" ABOVE FINISHED GRADE OR PER SUBDIVISION REQUIREMENTS, UNDERPIN ALL EXPOSED FOUNDATIONS.
- VERIFY METER AND UTILITY SERVICE LOCATIONS PRIOR TO INSTALLATION.
- EROSION CONTROL BARRIERS TO BE INSTALLED PRIOR TO COMMENCEMENT OF CONSTRUCTION.
- STABILIZED TEMPORARY CONSTRUCTION DRIVEWAY TO BE IN PLACE PRIOR TO COMMENCEMENT OF CONSTRUCTION.
- CONFIRM ALL DRIVEWAY, WALKWAY AND PVC LAYOUTS/LOCATIONS PRIOR TO COMMENCING WORK.
- PROVIDE CONTROL AND EXPANSION JOINTS AS REQUIRED ON CONCRETE DRIVES, WALKS AND PATIOS.
- LOCATION OF MAILBOX AND EXTERIOR DRIVEWAY LIGHT(S) TO BE VERIFIED PRIOR TO INSTALLATION.
- ALL CONSTRUCTION MATERIALS AND WASTE TO BE STORED ON SITE DURING CONSTRUCTION.
- LANDSCAPE PLANS TO BE PROVIDED BY OTHERS AND PERMIT FOR SAME TO BE OBTAINED SEPARATELY FROM THESE PLANS.
- CONTRACTOR SHALL CLEAN UP AREAS AFFECTED BY DAILY WORK AND REMOVE DEBRIS AND MATERIALS FROM THE SITE UPON COMPLETION OF THE WORK.
- DRIVEWAY TO BE INSTALLED PER COUNTY ORDINANCES

SITE LEGEND		MIN CLEAR SPACE
	ROOF OVERHANG	
	TREE TRUNK	
	ELECTRICAL SERVICE PANEL	
	ELECTRICAL METER	
	GAS METER	
	WATER METER	
	UTILITY POLE	
	OVER HEAD LINES	
	FENCE	
	GRINDER PUMP	
	PROPANE TANK	

○ SITE PLAN LEGEND
1/4" = 1'-0"

PARKING REQUIREMENTS

BUILDING OCCUPANCY = GROUP A-3

FUNERAL PARLOR
BUILDING OCCUPANCY = GROUP A-3

PARKING REQUIRED
1 SPACE PER 300 SF OF SPACE +/- 1459 = 5 PARKING SPOTS
1 to 25 RATIO ACCESSIBLE PARKING REQUIRED = 1

PARKING PROVIDED
STANDARD PARKING = 5
ACCESSIBLE PARKING = 1

TOTAL PARKING PROVIDED = 6

○ PARKING REQUIREMENTS
3/8" = 1'-0"

VISITABILITY LEGEND

	ACCESSIBLE / EGRESS ROUTE
	MIN CLEAR SPACE
	EXIT SIGN DISPLAY 216.4.1 EXIT DOORS, DOORS AT EXIT PASSAGEWAY, EXIT DISCHARGE AND EXIT STAIRWAYS SHALL BE IDENTIFIED BY TACTILE SIGNS COMPLYING WITH 703.1, 703.2
	FIRE EXTINGUISHER CABINET, RECESSED. PROVIDE OCCULT CABINET, STAINLESS FINISH WITH VERTICAL DUO WINDOW
	VISITABLE ENTRANCE VISITABLE NO STEP ENTRY MAX 1/2" BEVELED THRESHOLD 3'X3' MIN LANDING WITH MAX 1/4" /' FT SLOPE

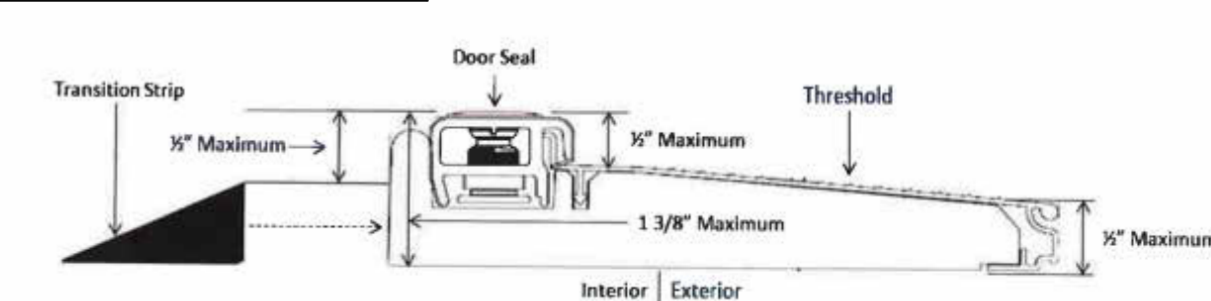

○ VISITABILITY LEGEND
3/8" = 1'-0"

① SITE PLAN
3/32" = 1'-0"

REV. #	DESC.	DATE

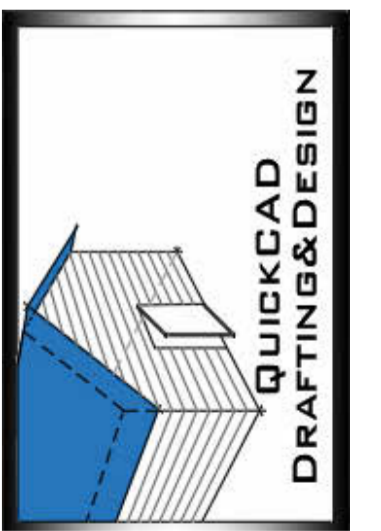

4926 Spicewood Springs RD
Ste#105, Austin TX

T: 512-822-5143
Equickcaddesign@outlook.com

As Indicated
Project Number



GENERAL DEMOLITION NOTES

1. PROTECT FROM DAMAGE EXISTING FINISH WORK THAT IS TO REMAIN IN PLACE AND BECOMES EXPOSED DURING DEMOLITION OPERATIONS.
2. WHEN DEMOLITION IS INDICATED OF AN ASSEMBLY, ALL COMPONENTS OF THE ASSEMBLY SHALL BE REMOVED WHETHER HIDDEN WITHIN THE NEW WORK.
3. WHERE EXISTING CEILING IS INDICATED TO BE REMOVED, ALL COMPONENTS OF THAT ASSEMBLY SHALL BE REMOVED. DUCTWORK WILL REMAIN IN PLACE UNLESS OTHERWISE NOTED.
4. BUILDER SHALL COORDINATE THE TERMINATION AND RELOCATION OF ALL ELECTRICAL SYSTEMS, SWITCH GEAR, EQUIPMENT, ETC. BEFORE STARTING ANY DEMOLITION OR REMOVAL OF ANY ASSEMBLIES.
5. REMOVE ELECTRICAL FIXTURES, WIRING, AND EQUIPMENT AS REQUIRED. REMOVE CONDUIT AND WIRES SERVICING ELECTRICAL EQUIPMENT TO DISTRIBUTION PANELS UNLESS OTHERWISE NOTED.
6. EXISTING UTILITIES TO REMAIN ARE TO BE KEPT IN SERVICE THROUGHOUT COURSE OF THE WORK. CERTAIN SERVICE ELEMENTS MAY BE LOCATED IN AND THROUGH DEMOLISHED ASSEMBLIES. THESE SERVICES SHALL BE REMOVED, RE ROUTED, AND REPLACED AS REQUIRED BY THE BUILDER.
7. IF ANY CONFLICT BETWEEN ELECTRICAL, MECHANICAL, OR STRUCTURAL ELEMENTS IN REGARDS TO THE DESIGN SHOULD OCCUR, THE BUILDER IS RESPONSIBLE FOR CONTACTING THE ARCHITECT.
8. REMOVE TELEPHONE FIXTURES, WIRING, AND EQUIPMENT AS REQUIRED.
9. UPON COMPLETION OF DEMOLITION WORK, ALL TOOLS, EQUIPMENT, AND DEMOLISHED MATERIALS ARE TO BE REMOVED FROM THE SITE. PROTECTION APPLIED TO ANY FINISH WORK IS TO BE REMOVED AND INTERIOR AREAS ARE TO BE LEFT BROOM CLEAN.

DEMOLITION KEY NOTES

1	DEMO FOR NEW DOOR OPENING 4'WX7'H
2	REMOVE EXISTING VANITY SINK , REPLACE WITH ADA COMPLIANCE
3	REMOVE AND DISPOSE TUB, PLUBING FIXTURES AND RELATED FINISHES
4	REMOVE DOOR AND TRIM
5	DEMO WALL FORE NEW DOOR OPENING 5'WX7'H
6	REMOVE PORTION RAIL TO ALLOW NEW ADA RAMP
7	REMOVE AND CAP OFF EXISTING PLUMBING FIXTURES

EXAMPLES OF DEMO NOTES
DELETE THOSE NOT NEEDED

DEMOLITION LEGEND

	WALLS, FLOORS, AND FIXTURES TO BE DEMOLISHED
	WINDOWS TO BE REMOVED
	DOOR TO BE REMOVED

REV. #	DESC.	DATE

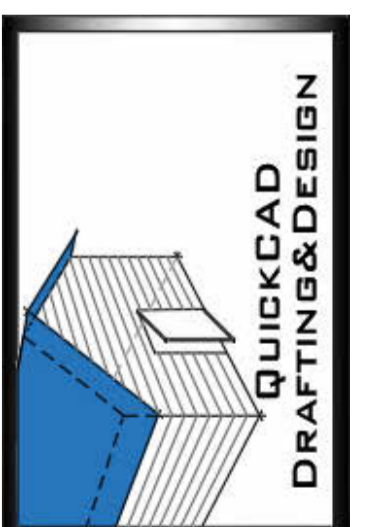

4926 Spicewood Springs RD
Ste#105, Austin TX

T: 512-822-5143
Equickcaddesign@outlook.com

As Indicated

Project Number

A106

EXISTING / DEMO

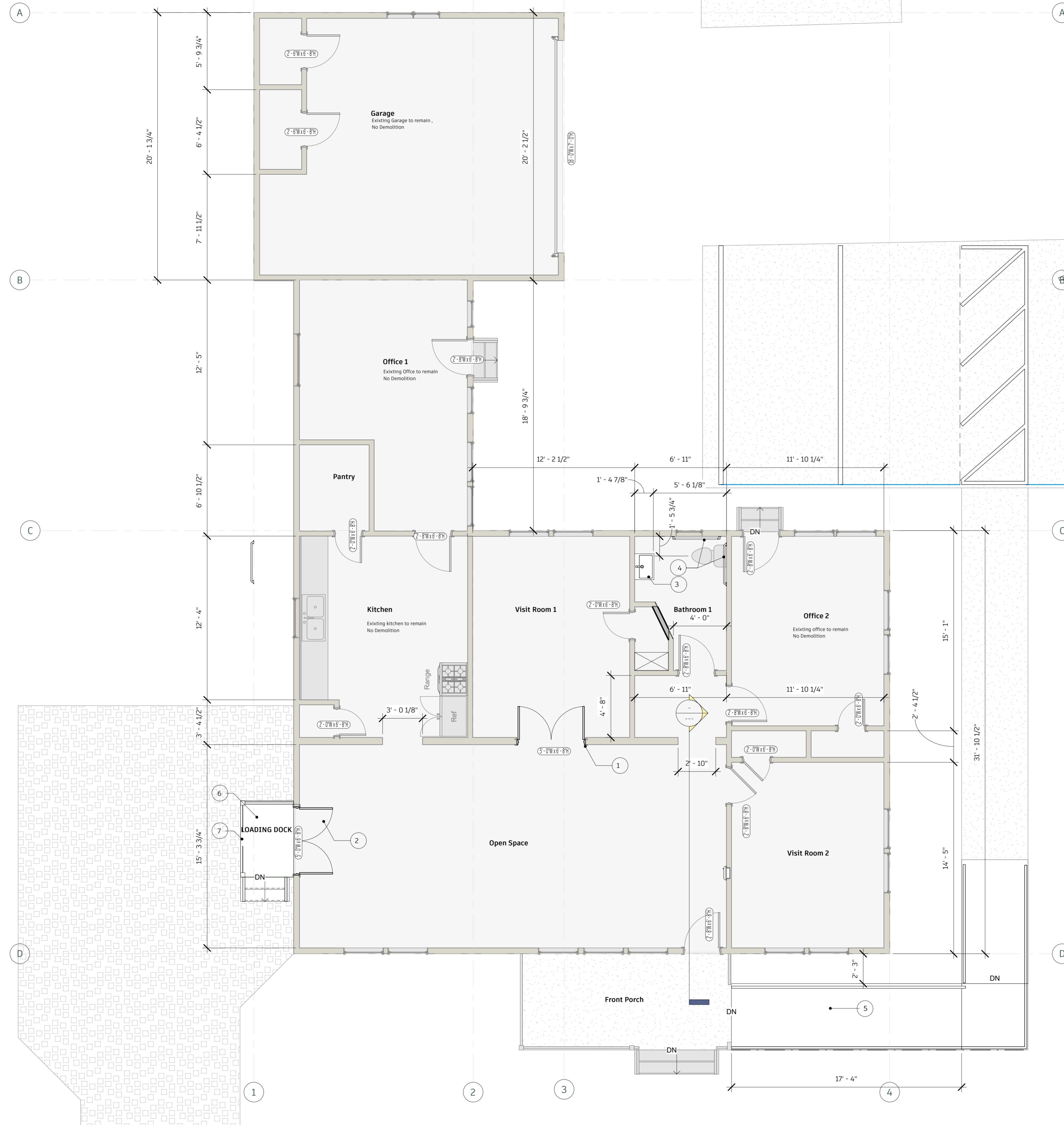

FLOOR PLAN NOTES

1. CONTRACTOR SHALL FIELD VERIFY AND CORRELATE ALL DIMENSIONS ON THE JOBSITE.
2. FIELD VERIFY AND USE DIMENSIONS AS INDICATED. DO NOT SCALE DIMENSIONS FROM THE DRAWINGS.
3. CONTRACTOR TO LOCATE AND LAY OUT ALL WALLS AND PARTITIONS AS THEY RELATE TO THE STRUCTURE AND OTHER BUILDING ELEMENTS AS SHOWN ON THE DRAWINGS, AND IN CONFORMANCE WITH THE DESIGN CONCEPT AND INTENT.
4. ALL FLOOR PLAN DIMENSIONS ARE TO THE FACE OF PLYWOOD SHEATHING OR GYPSUM BOARD AT WOOD FRAME EXTERIOR WALLS OR INTERIOR PARTITIONS OR FURRING ASSEMBLIES, THE FACE OF THE EXTERIOR/PERIMETER EDGE OF THE CONCRETE SLAB OR FOUNDATION WALLS, GRID LINES OR THE CENTER LINE OF COLUMNS AND BEAMS; THE FACE OF MASONRY WALLS OR VENEERS (OTO); THE FACE OF THE WINDOW FRAMES OR HOLLOW METAL DOOR FRAMES; THE EXPOSED FACADE OF WOOD DOOR FRAMES (JAMBS) AT NOMINAL DOOR OPENINGS; UNLESS NOTED OTHERWISE, (U.N.O).
5. FLOOR PLAN DIMENSIONS AT THE EXTERIOR PERIMETER WALLS ARE TO THE FACE OF THE SHEARING (OSB, PLYWOOD, GYPSUM) AND THE EDGE OF THE CONCRETE SLAB FOUNDATION, AND DO NOT INCLUDE THE THICKNESS OF THE EXTERIOR FINISH MATERIALS; FIBER CEMENT OR WOOD SIDING AND TRIM; STUCCO OR CEMENT PLASTER AND/OR METAL WALL PANELS AND TRIM, OR OTHER MATERIALS AS INDICATED OR NOTED. FLOOR PLAN DIMENSIONS AT EXTERIOR PERIMETER CAVITY WALLS WITH MASONRY OR STONE VENEERS ARE TO THE FACE OF THE MASONRY OR STONE VENEERS AND THE EDGE OF THE CONCRETE SLAB FOUNDATION, UNLESS NOTED OR INDICATED OTHERWISE.
6. DIMENSIONS NOTED AS CLR. (CLEAR) AND O.T.O (OUTSIDE TO OUTSIDE) ARE TO FINISH WALL OR PARTITIONS SURFACES.
7. PROVIDE CONCEALED WOOD BLOCKING, WOOD SUPPORT FRAMEWORK AND BRACING, AND ALL MISC. WOOD NAILERS, ETC, AS REQUIRED.
8. PROVIDE CONCEALED WOOD BLOCKING, CONTINUOUS, WHERE REQUIRED IN ALL WOOD STUD PARTITIONS FOR THE PROPER ANCHORAGE OF WALL ATTACHED ITEMS, SUCH AS MIRRORS, TOILET ACCESSORIES, FUTURE GRAB BARS, WALL HUNG AND BASE CABINETS, COUNTERTOPS, WALL HUNG LAVATORIES, CLOSET RODS, CLOSET LEDGER STRIPS AND SHELVES, METALS SHELF BRACKETS, OWNER PROVIDED CLOSET SYSTEM.
9. ALL INTERIOR PARTITION WALLS EXTEND TO THE STRUCTURE OR BOTTOM OF CEILING/FLOOR FRAMING OR CEILING/ROOF FRAMING, UNLESS NOTED OR INDICATED OTHERWISE. ALL INTERIOR PARTITIONS THAT DO NOT EXTEND TO THE FRAMING SHALL BE BRACED TO THE STRUCTURE AS REQUIRED TO PREVENT MOVEMENT OR DEFLECTION.
10. NOTIFY THE ARCHITECT IMMEDIATELY OF DISCREPANCIES IN THE DRAWINGS, BETWEEN THE DRAWINGS AND SPECIFICATIONS, OR BETWEEN THE DRAWINGS AND ACTUAL JOB CONDITIONS WHICH AFFECT THE EXECUTION OF THE WORK AS INTENDED. THE ARCHITECT WILL ISSUE A CLARIFICATION OR PREPARE ALTERNATE DOCUMENTS WHICH MAY BE REQUIRED.
11. THE CONTRACTOR IS RESPONSIBLE FOR COORDINATING THE WORK OF ALL TRADES, FOR CHECKING AND COORDINATING ALL CONTRACT DOCUMENTS, SUBMITTALS, FIELD CONDITIONS AND DIMENSIONS FOR ACCURACY, AND CONFIRMING THAT THE WORK IS BUILDABLE AS SHOWN AND INTENDED, BEFORE PROCEEDING WITH CONSTRUCTION. IF THERE ARE QUESTIONS REGARDING THESE OR ANY OTHER COORDINATION ISSUES, THE CONTRACTOR IS RESPONSIBLE FOR OBTAINING CLARIFICATION FROM THE ARCHITECT REGARDING THE WORK, OR ANY RELATED WORK, IN QUESTION, BEFORE PROCEEDING WITH THE WORK.
12. AREA QUANTITIES NOTED ON THE PLAN DRAWINGS ARE PROVIDED FOR INFORMATION PURPOSES ONLY. CONTRACTOR IS RESPONSIBLE FOR FIELD VERIFICATION OF ALL DIMENSIONS AND AREA CALCULATIONS UTILIZED TO DETERMINE HIS COSTS AND QUANTITIES NECESSARY TO PROVIDE ALL LABOR, MATERIALS, COMPONENTS, AND ACCESSORIES REQUIRED TO COMPLETE WORK.
13. DIMENSIONS SHOWN ARE FOR NOMINAL OPENINGS; FRAMERS SHALL ALLOW ROUGH OPENING CLEARANCES ARE REQUIRED.
14. ALL NEW STAIRS, STEPS, AND RAILINGS TO MEET CURRENT CODES AT THE TIME OF CONSTRUCTION
15. GARAGE TO BE SEPARATED FROM HOUSE BY 5/8" TYPE X GYP ON WALLS AND CEILINGS COMMON WITH THE HOUSE. DOOR TO BE 20 MIN. RATED WITH A SELF CLOSER.

REMODEL KEY NOTES

NO.	DESCRIPTION
1	NEW INTERIOR DOUBLE DOOR 5'W X 6'8\"/>

REMODEL KEY NOTES
1/4" = 1'-0"

1 NEW FLOOR PLAN
1/4" = 1'-0"

REV. #	DESC.	DATE

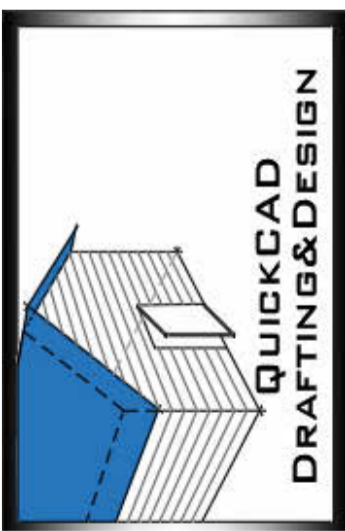

4926 Spicewood Springs RD
Ste#105, Austin TX

T: 512-822-5143
Equickcaddesign@outlook.com

1/4" = 1'-0"

Project Number

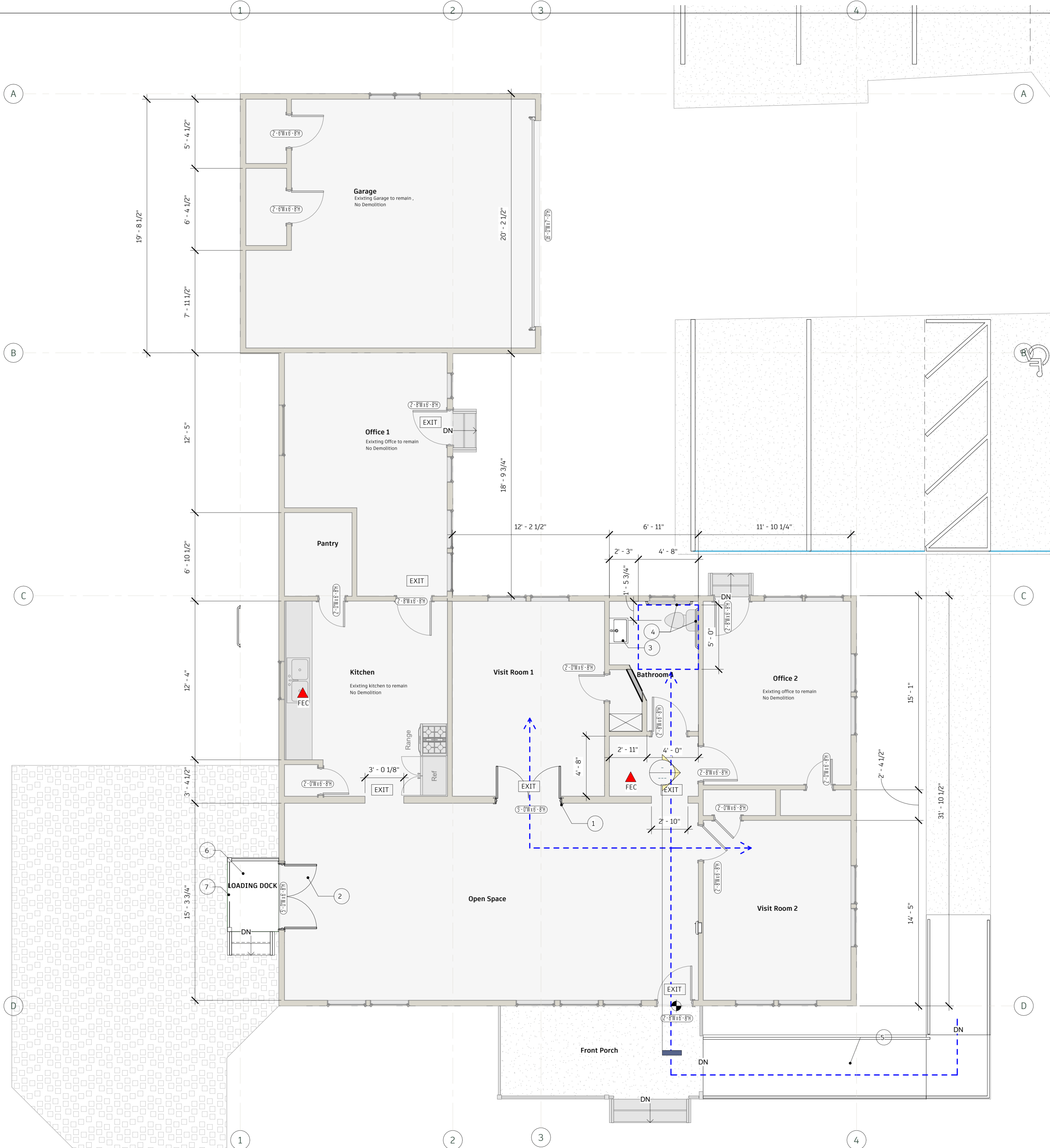

REMODEL KEY NOTES	
1	NEW INTERIOR DOUBLE DOOR 5'W X 6'8"H
2	NEW EXTERIOR DOOR 5'W X 6'8" H
3	NEW WALL HANG ADA COMPLIANT SINK
4	INSTALL NEW SAFETY GRAB BARS
5	NEW ADA COMPLIANT RAMP REFER TO ADA GENERAL NOTES FOR SLOPE, HANDRAILS AND LANDINGS
6	REMOVE PORTION RAIL TO ALLOW NEW ADA RAMP
7	REMOVABLE SAFETY CHAIN

REMODEL KEY NOTES
1/4" = 1'-0"

VISITABILITY LEGEND	
	ACCESSIBLE / EGRESS ROUTE
	MIN CLEAR SPACE
	EXIT SIGN DISPLAY 216.4.1 EXIT DOORS, DOORS AT EXIT PASSAGEWAY, EXIT DISCHARGE AND EXIT STAIRWAYS SHALL BE IDENTIFIED BY TACTILE SIGNS COMPLYING WITH 703.1, 703.2
	FIRE EXTINGUISHER CABINET, RECESSED. PROVIDE OCCULT CABINET, STAINLESS FINISH WITH VERTICAL DUO WINDOW
	VISITABLE ENTRANCE VISITABLE NO STEP ENTRY MAX 1/2" BEVELED THRESHOLD 3'X3' MIN LANDING WITH MAX 1/4" / FT SLOPE

VISITABILITY LEGEND
3/8" = 1'-0"

1 ACCESSIBILITY FLOOR PLAN
1/4" = 1'-0"

REV. #	DESC.	DATE

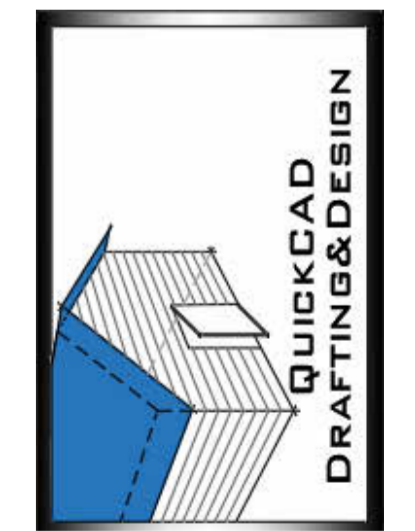







4926 Spicewood Springs RD
Ste#105, Austin TX

T: 512-822-5143
Equickcaddesign@outlook.com

As Indicated
Project Number

BROWN FUNERAL HOUSE

800 Lexington St, Manor TX

-  MATERIAL 1
-  MATERIAL 1
-  MATERIAL 1
-  MATERIAL 1
-  MATERIAL 1
-  MATERIAL 1
-  MATERIAL 1

MATERIAL LEGEND
 1/4" = 1'-0"

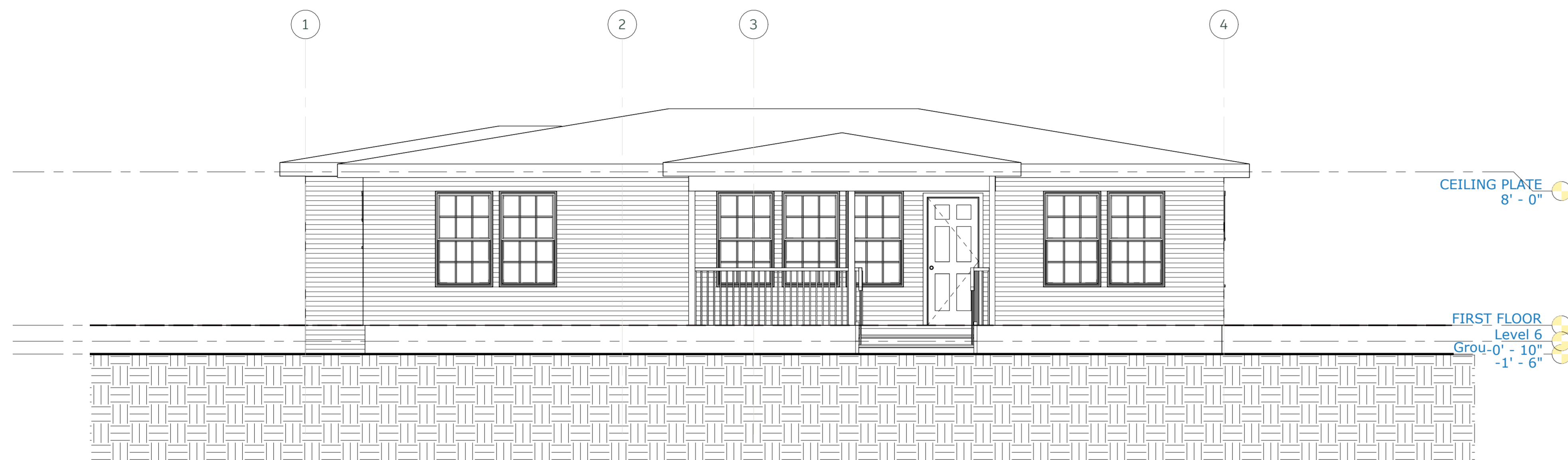

1 EXISTING NORTH ELEVATION
 1/4" = 1'-0"

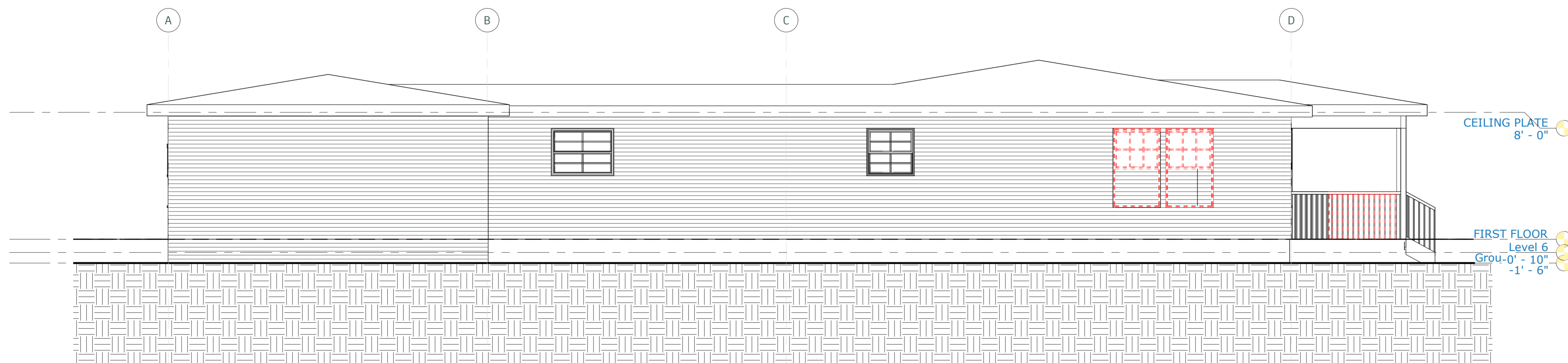

2 EXISTING LEFT ELEVATION
 1/4" = 1'-0"

REV. #	DESC.	DATE

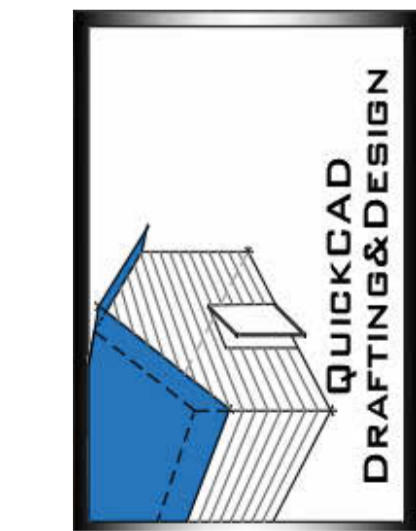

4926 Spicewood Springs RD
 Ste#105, Austin TX
 T: 512-822-5143
 Equickcaddesign@outlook.com

1/4" = 1'-0"

Project Number

A201

EXISTING
 ELEVATIONS

BROWN FUNERAL HOUSE

800 Lexington St, Manor TX



① EXISTING RIGHT ELEVATION
 1/4" = 1'-0"

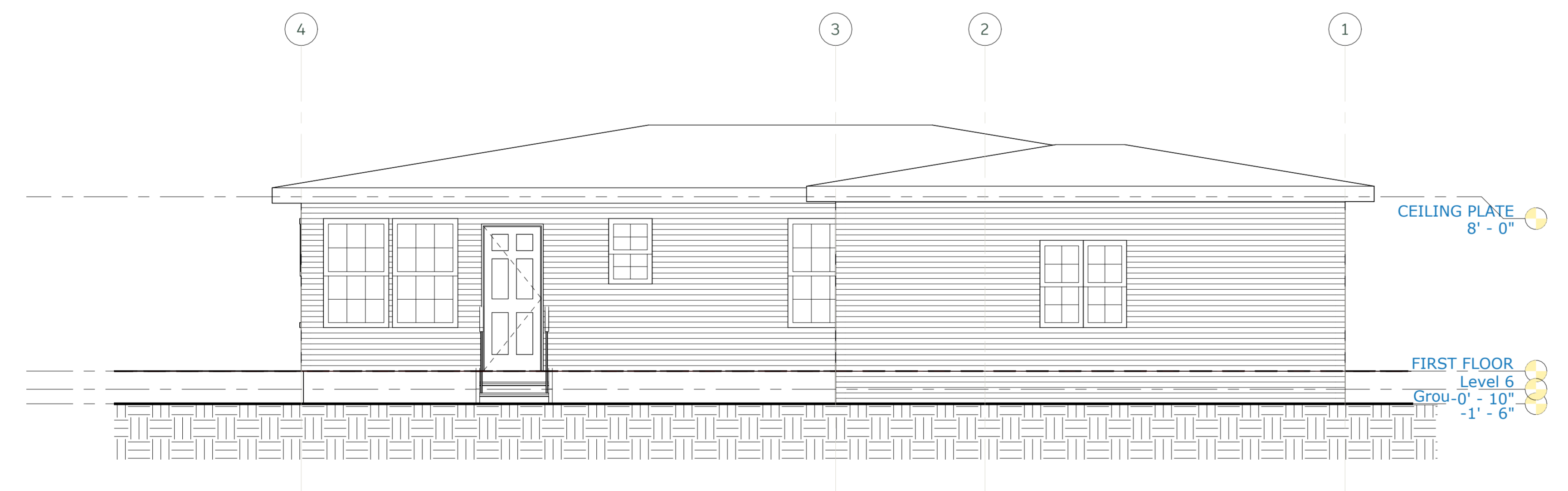

② EXISTING SOUTH ELEVATION
 1/4" = 1'-0"

REV. #	DESC.	DATE

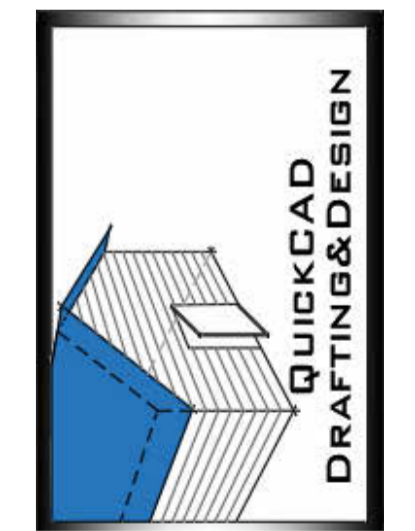

4926 Spicewood Springs RD
 Ste#105, Austin TX

T: 512-822-5143
 Equickcaddesign@outlook.com

1/4" = 1'-0"

Project Number

A202

EXISTING
 ELEVATIONS

BROWN FUNERAL HOUSE

800 Lexington St, Manor TX



② NEW NORTH ELEVATION
 1/4" = 1'-0"

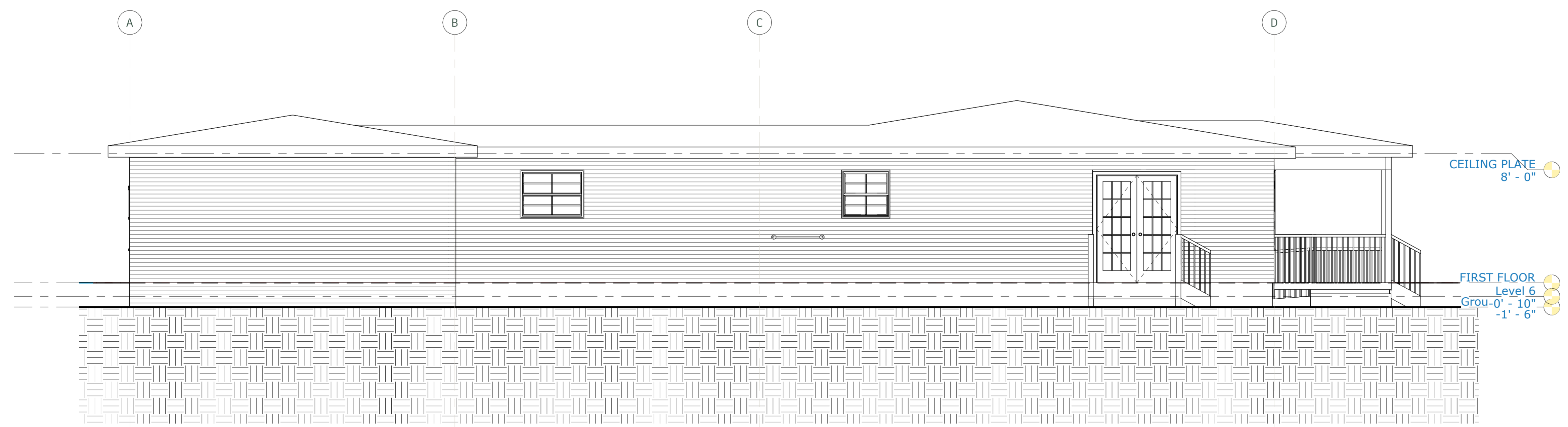

① NEW LEFT ELEVATION
 1/4" = 1'-0"

REV. #	DESC.	DATE

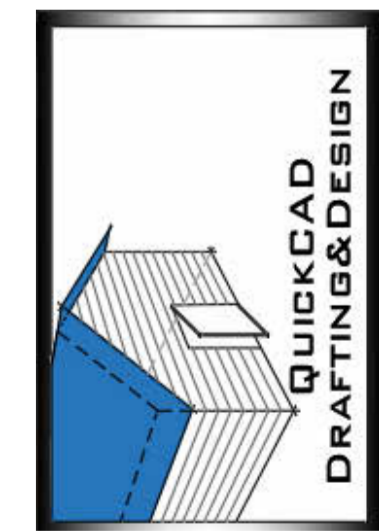

4926 Spicewood Springs RD
 Ste#105, Austin TX
 T: 512-822-5143
 Equickcaddesign@outlook.com

1/4" = 1'-0"

Project Number

A203

NEW ELEVATIONS

BROWN FUNERAL HOUSE

800 Lexington St, Manor TX



① NEW RIGHT ELEVATION
 1/4" = 1'-0"

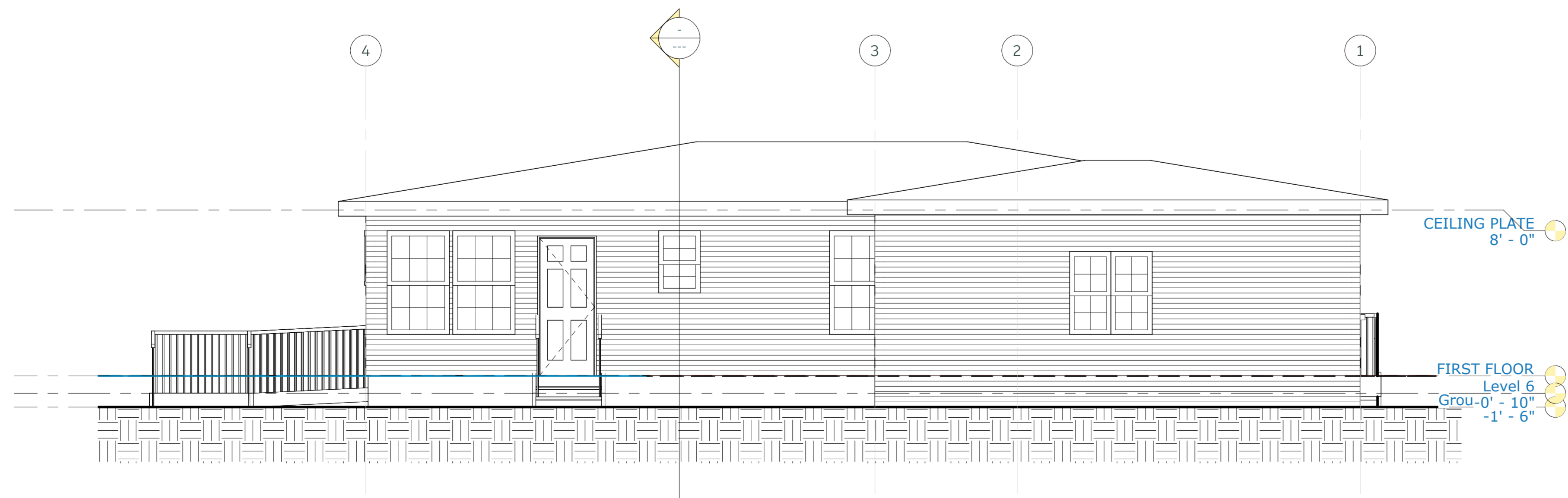

② NEW SOUTH ELEVATION
 1/4" = 1'-0"

REV. #	DESC.	DATE

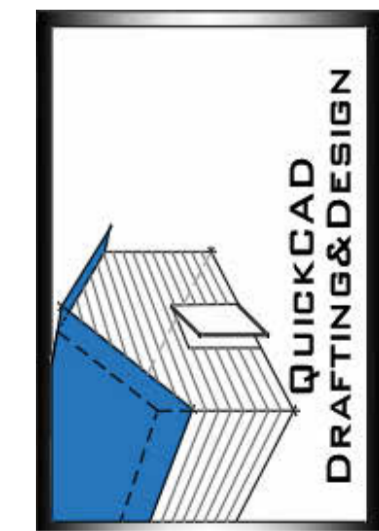

4926 Spicewood Springs RD
 Ste#105, Austin TX
 T: 512-822-5143
 Equickcaddesign@outlook.com

1/4" = 1'-0"

Project Number

A204

NEW ELEVATIONS

GENERAL

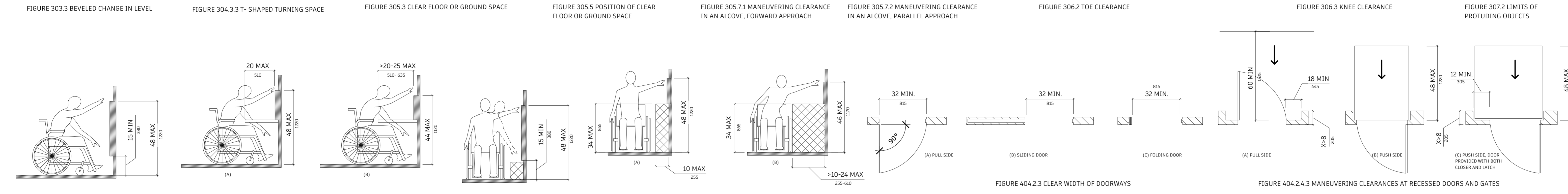
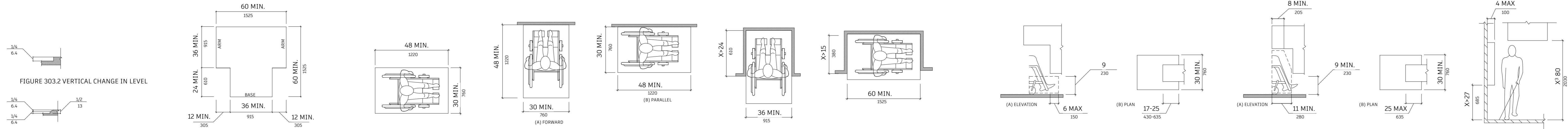

RAMPS AND STAIRS

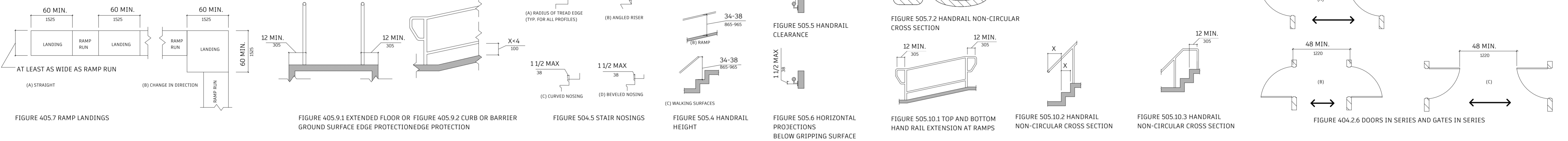

TOILET AND BATHING ROOMS

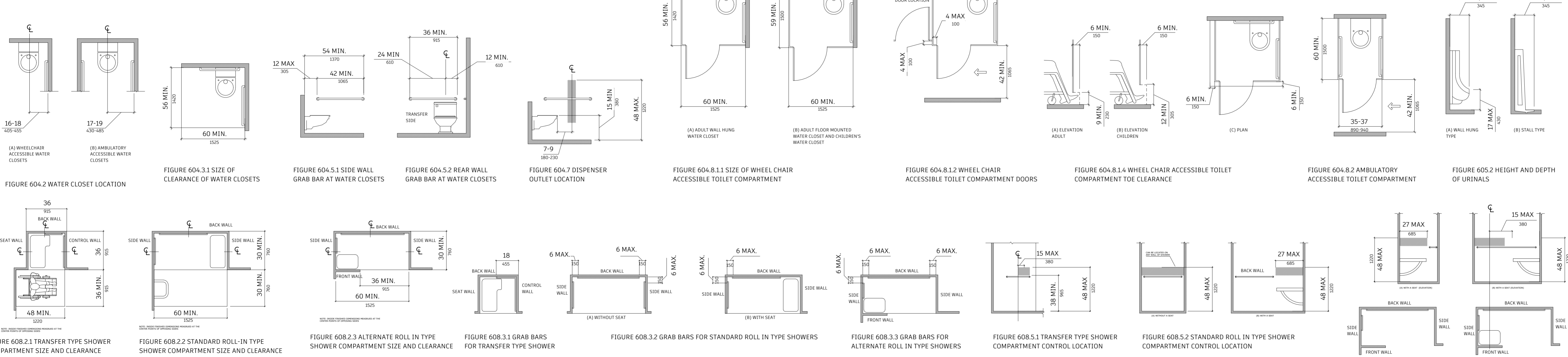

SIGNAGE

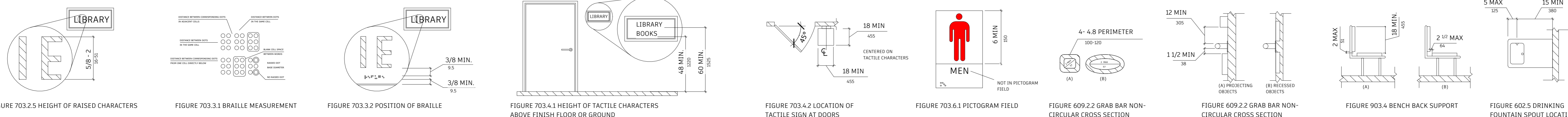

BROWN FUNERAL HOUSE
800 Lexington St, Manor TX

REV. #	DESC.	DATE

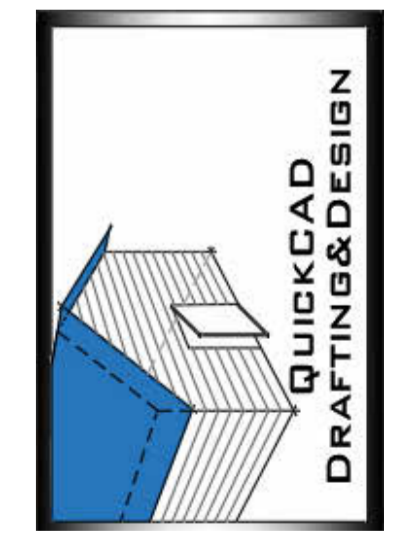

4926 Spicewood Springs RD
Ste#105, Austin TX

T: 512-822-5143
Equickcadesign@outlook.com

As indicated
Project Number

G2
ADA NOTES