

Bid Request Form

Originating Department: Recreation Contact Person: Kory Alfred
 Bid Title: Hexagon Open-Air Pickleball Courts Funding Source: 10-050-2951.00

Checklist

Information required for all bids:

- Desired start date for project: 5-15-23
- Desired council date for award: 5-8-23
- Is this bid for services, equipment, or both
- Does this bid involve multiple phases? Yes No
- Cost estimate/budget: \$ 226,057.00
- Complete specifications including quantities and sizes
- Any alternates to be included in bid? Yes No
- Provided project description for ad? Yes No
- Pre-bid conference? Yes No
 If yes, mandatory or optional

If applicable:

- Current contract end date: N/A
- Startup time required for new vendor: N/A
- Property acquisitions complete? Yes No
- Include any drawings, plans, or maps (engineer stamped drawings for Public Works projects)
- Working with an architect or consultant? Yes No
- Project completion timeframe/date: 120
- Amount for liquidated damages: \$ 100.00
- For Title 41 bids, require a bid bond? Yes No
 require a performance bond? Yes No

Is the desired service/equipment available from the Alabama State Bid List, GSA, or from any of the following Purchasing Cooperatives: H-GAC, NCPA, NASPO, Sourcewell, Omnia Partners, BuyBoard, TIPS, or NPPGov?

Notes: _____

Madison Parks and Recreation Dept.
8324 Madison Pike
Madison, Alabama
256-772-9300
Kory Alfred
Kelly Johnson

Hexagon
305 Intergraph Way
Madison, Alabama

Hexagon tennis court conversion to Pickleball facility 240' x 108'

Project Description: This project consists of converting four existing tennis courts to twelve pickleball courts. The courts measure 240' x 108' and when completed the new 12 pickleball courts will measure approximately the same. The work consists of furnishing all the materials and labor to demo the existing courts (4) and rebuild to meet or exceed the enclosed specifications. The work shall consist of but is not limited to removal and disposal of the existing fence, removal and disposal of the existing net posts/anchor footing, and the existing asphalt pavement.

Upon removal from the site, the existing base course shall be regraded and compacted while adding an additional 2-3 inches of new limestone base, a new perimeter concrete curb, installing new fencing, new net post/anchor footings, a new color coat system with lines and markings for 12 new pickleball courts.

When completed, this facility will be American with Disabilities Act (ADA) accessible to players and spectators in wheelchairs and to those with other disabilities.

Existing pavement conversion typical follows:

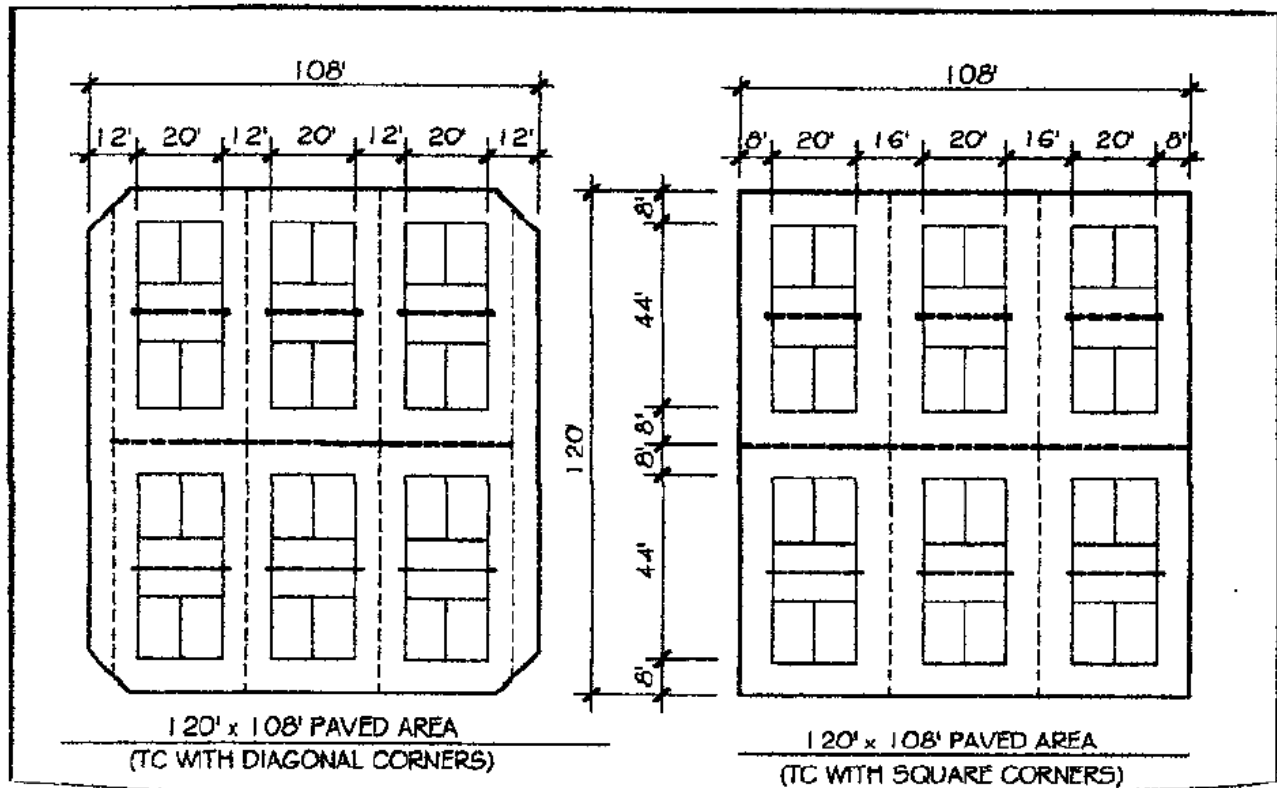

Base course rock (dense graded base rock/limestone)

- Slope shall be 1 %/1.2 inches per ten ft.
- Continuous slope shall be sloped from west to east
- The high side being the west side (approx 1 ft and 2 inches) all in one plane
- The existing base course shall be plowed up
- Two inches of new limestone base shall be added to the existing base course
- The new base shall be a minimum of six inches thick when compacted
- The new base shall be installed with laser controlled equipment
- The new base shall be thoroughly compacted with steel wheel tandem rollers
- The newly compacted base course shall be 97% density when completed
- The final tolerance in the base shall be 1/2 inch in 10 ft. when measured in any direction.
- We will require a minimum of 6-inch-thick base rock layer when completed.

Please provide a unit cost (per ton) for additional limestone dense graded base that may or may not be needed to achieve to desired thickness of six inches. The unit cost shall include labor, material, delivery and installation.

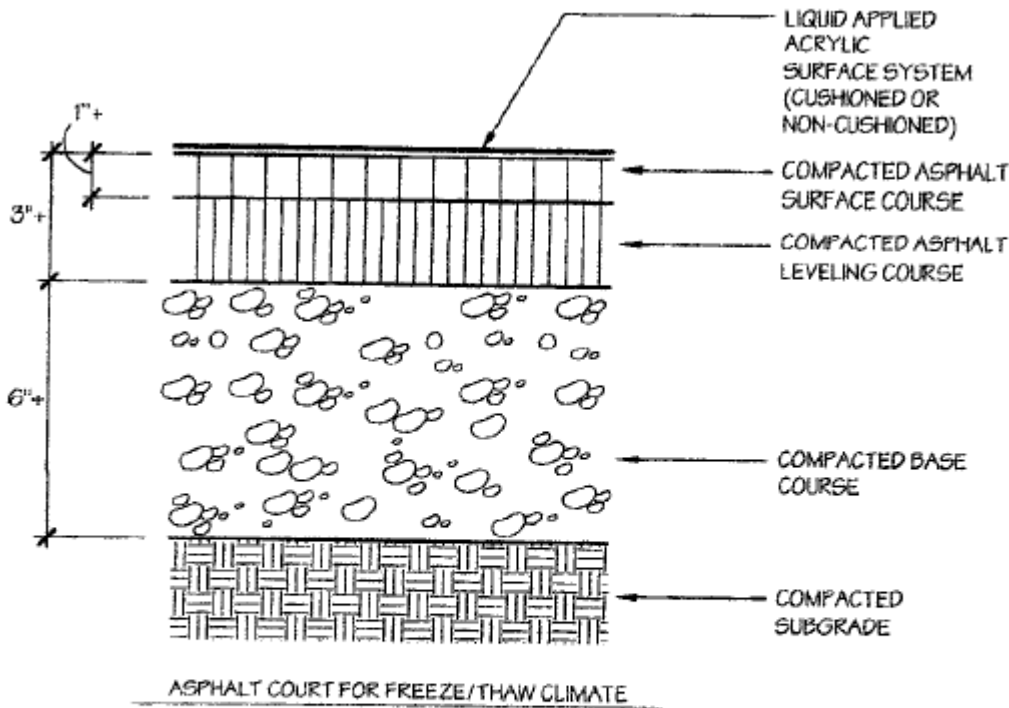

ASPHALT COURT SECTIONS

NOT TO SCALE

Concrete perimeter curb: (12" width and 1' 6" deep)

- The concrete curb is used to keep the base rock course from moving and also strengthening the perimeter fencing.
- The forms for the concrete curb shall be installed with laser grade equipment
- The final top elevation of the concrete curb shall be determined upon completion of the stone base course
- The desired final elevation shall represent the top of the newly installed asphalt pavement
- The curb shall be poured with 3000 PSI concrete ready mix with rebar every 10 ft.
- Sleeves for the fence post are to be installed on ten ft. centers.
- Sleeves are to be installed by the fence contractor
- See tennis edge detail typical below

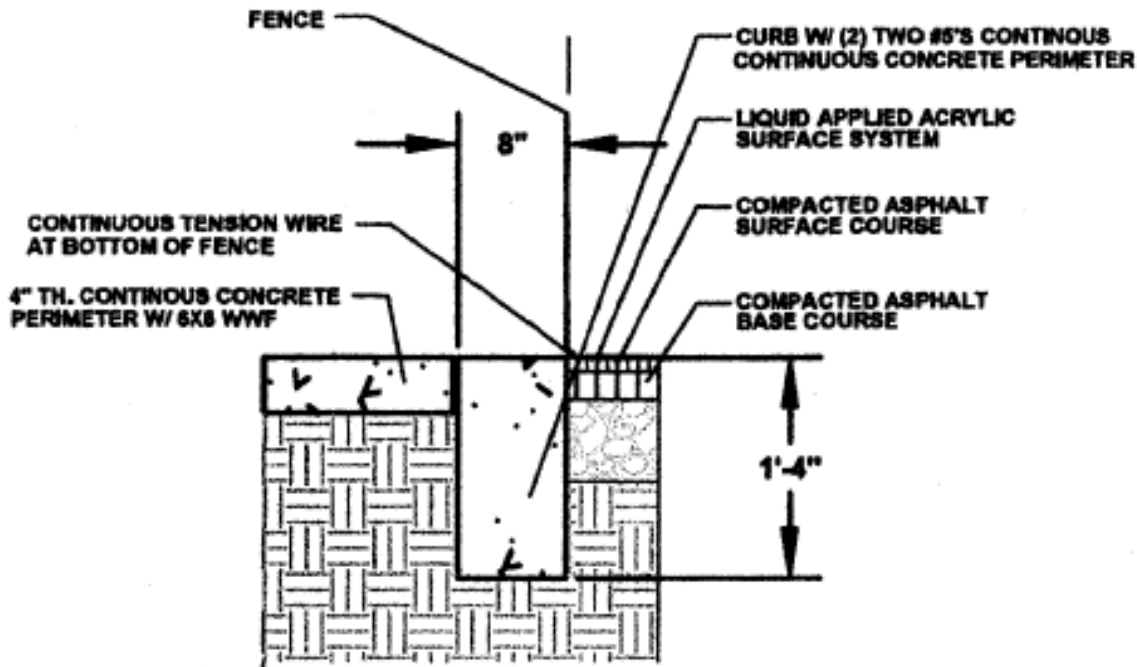

Typical Tennis Edge Detail

Hot mix Asphalt Pavement: (2" binder, 1" topping)

- Apply an emulsion tack coat over entire base rock layer.
- Construct a two-inch intermediate course of bituminous asphalt concrete or blacktop over the limestone rock base.
- Compact this mixture with tandem vibratory steel wheel roller
- Apply an emulsion tack coat over the binder asphalt pavement
- Construct a one-inch top layer of asphalt pavement over the binder course and compact
- The use of asphalt mixtures with RAP or RAS will not be accepted
- Required batch plant manufacturers to submit asphalt pavement designs for the one-inch topping to insure the asphalt mixture is within the desired specification for sport-related applications. (meeting ALDOT 424, 3/8" minus)
- The final tolerance in the asphalt shall be 1/4 inch in 10 ft when measured in any direction.
- Pavement irregularities as shown on the enclosed typical will not be acceptable. (see planarity, evenness, and irregularities and asphalt court sections -typical)

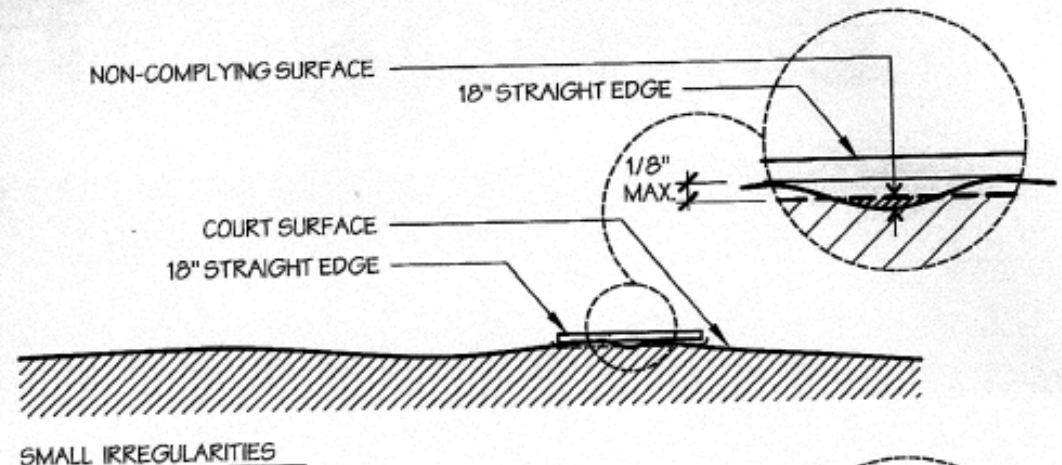

SMALL IRREGULARITIES

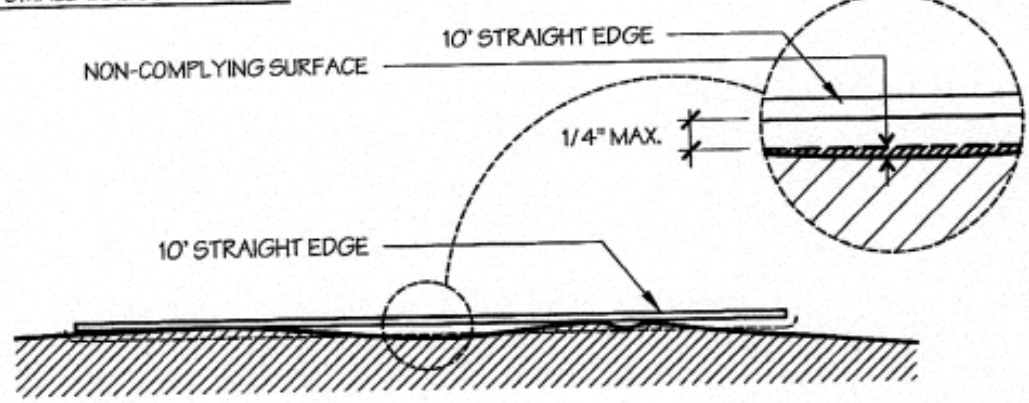

CHECKING EVENNESS

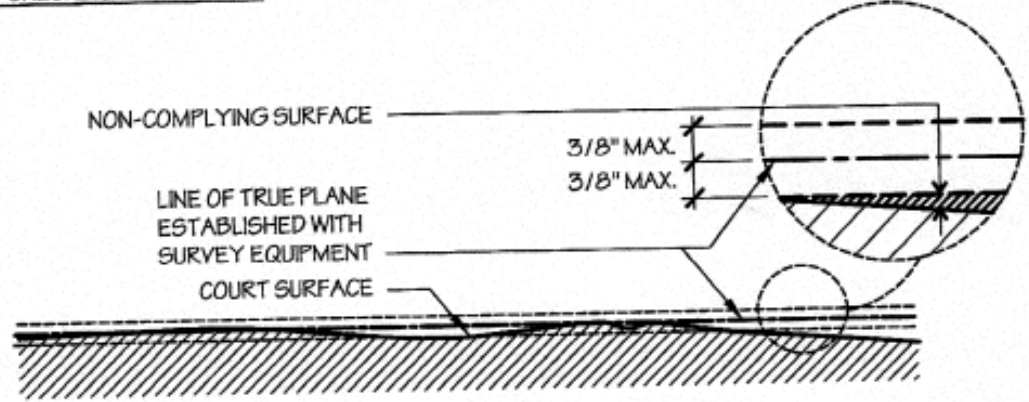

CHECKING PLANARITY

ILLUSTRATION OF HOW TO CHECK PLANARITY, EVENNESS & IRREGULARITIES

NOT TO SCALE

Fencing:

All fencing shall be PVC-vinyl coated meeting ASTM standards. Posts, rails, chain link fabric, gates, fasteners, tie wire, caps, etc. (color to be determined by owner)

- Height of fencing shall be eight foot and 9-gauge vinyl coated
- Three-inch O.D. terminal post schedule 40
- 2.5-inch O. D. line post schedule 40
- 1 5/8" O.D. Top and bottom rail/tubing
- All gates shall be minimum of 4 ft. width and meet ADA standards
- Owner to determine the amount of fencing that will be used on the west and east sides.
- See poured concrete edging typical – Page three

Net Posts, Anchors and nets:

- Layout and excavate holes at the required standard locations for pickleball. Each hole shall measure 2' x 2' x 2.5' deep for the posts
- Each center anchor hole shall measure 12" x 12" x 12" deep
- Each post hole shall have three, four ft long #5 rebar driven in the bottom of the holes that surround a new schedule 40 PVC sleeve
- Each hole shall be formed with 2 x 4 's on top of the new final bituminous asphalt layer
- The anchor holes will not need rebar or forms
- The net post shall be 2 7/8" O.D. Steel with external cranks (Edwards or equal)
- Center pipe anchor is to be 8" galvanized
- The sleeves for the net posts are to be schedule 40 PVC 3" I.D.
- Nets shall be Douglas JTN-30 PB/Q5 tennis nets with 4 yr. warranty or equal
- See post and net typicals – follows this page.

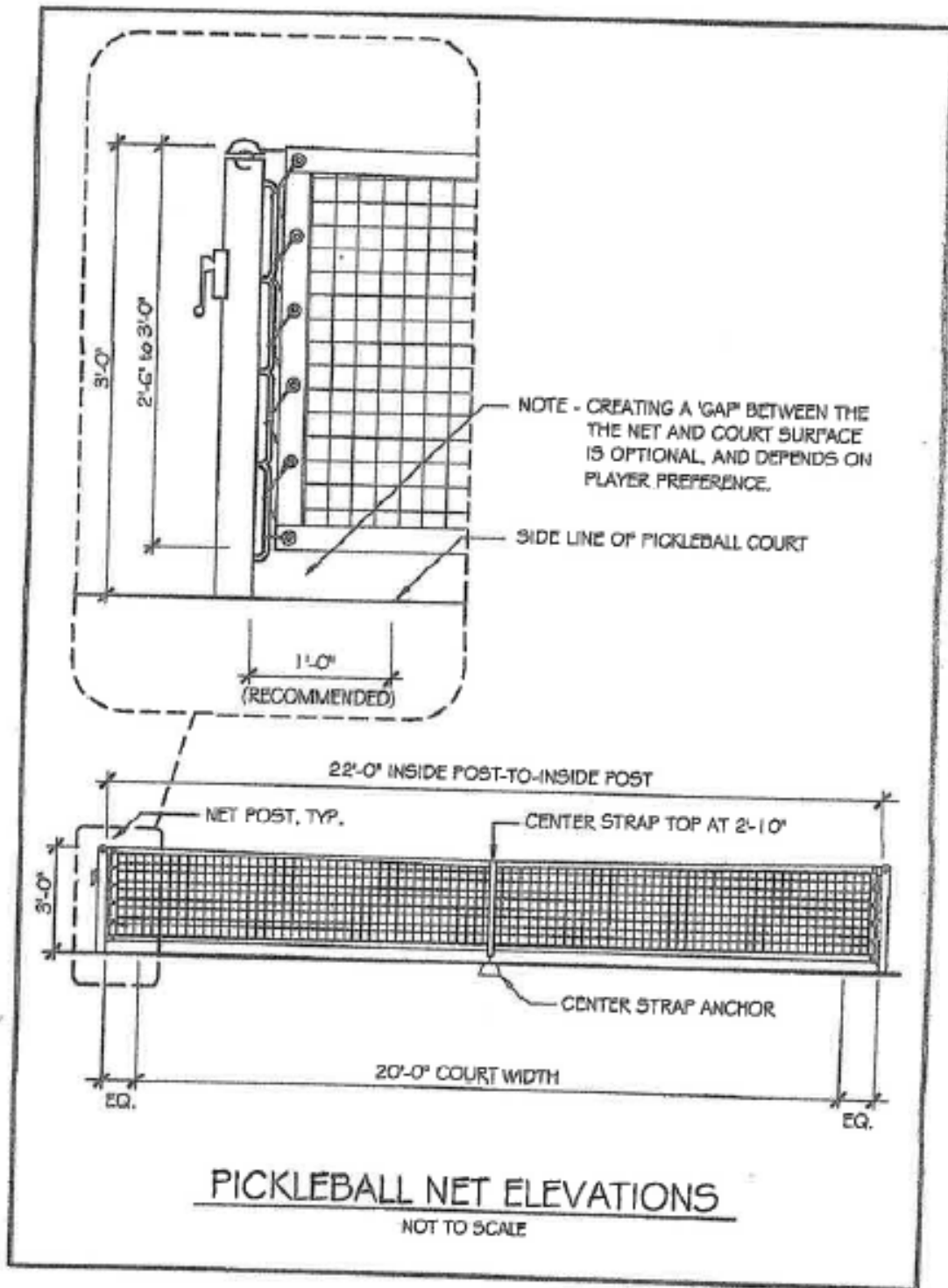

02NETELEV.AVL.20

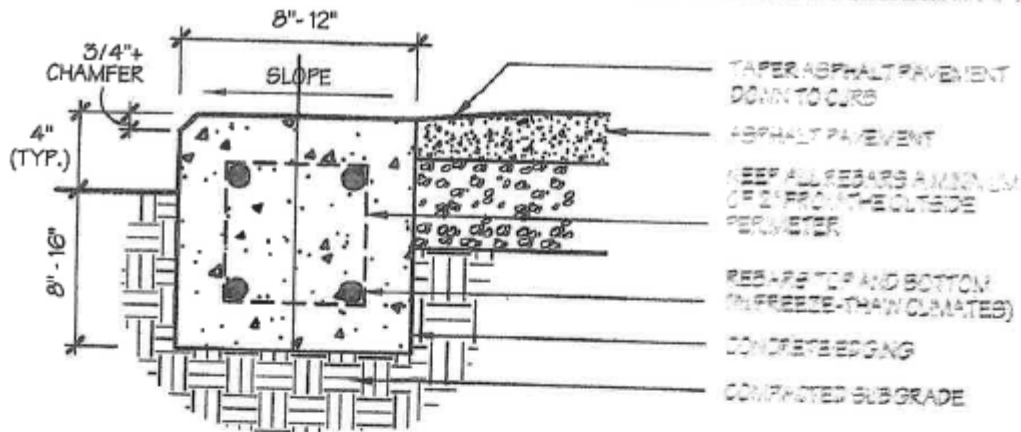

SECTION - CONCRETE COURT EDGING

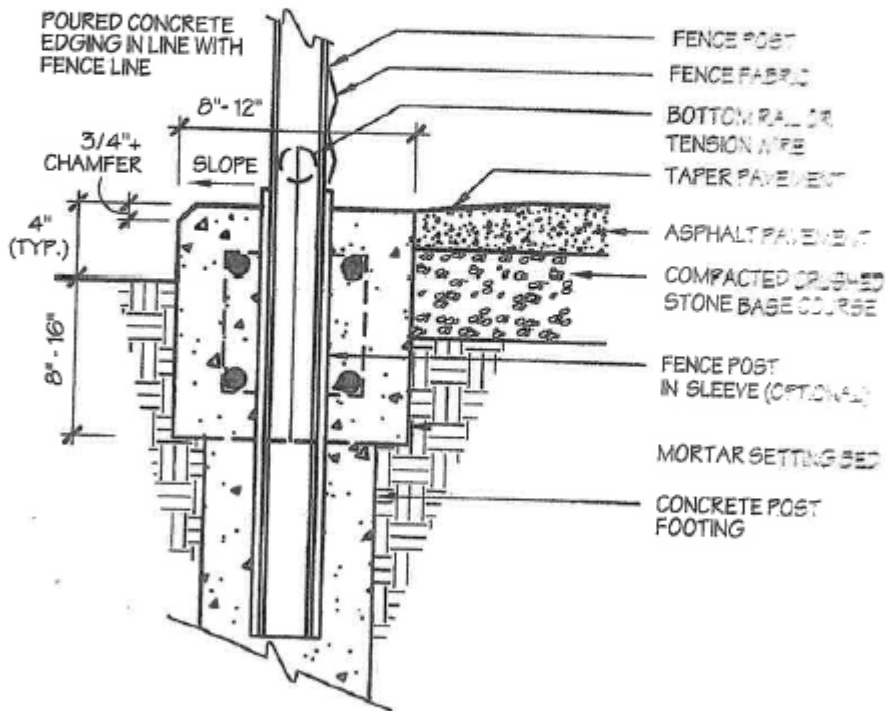

SECTION CONCRETE EDGING @ FENCE POST

POURED CONCRETE EDGING
FOR ASPHALT COURT

NOT TO SCALE

SportMaster Color Surface System Specification with lines and markings PickleMaster

PickleMaster is a specialized coating system designed for use on pickleball court surfaces. PickleMaster is factory-textured to provide a safe, non-slip surface with a non-aggressive texture to minimize ball wear. Seventeen color choices are available.

- Thoroughly clean court's surface of all loose debris
- Flood courts with water and mark all pavement irregularities with a construction crayon (low spots, pavement roller marks, seams, etc.)
- Fill and level all existing low areas and pavement irregularities holding water greater than 1/8"
- Apply 1st coat of acrylic resurfacer
- Apply 2nd coat of acrylic resurfacer (.08 gal per s.y.)
- Apply a mixture of two coats of PickleMaster color surface systems.
- Layout and paint all lines and markings at the required standard locations.

Exclusions:

- Any work outside the fence and concrete curb perimeter Relocation of existing utilities
- Unforeseen or underground utilities/relocation of existing utilities
- Testing and inspection fees
- Any and all work outside of grading and site layout plans
- Landscape/irrigation
- Rotten or unsuitable soils
- Trees and stumps
- Retaining walls
- ADA concrete compliance work
- Sidewalks
- Restrooms
- Seating/player/spectator

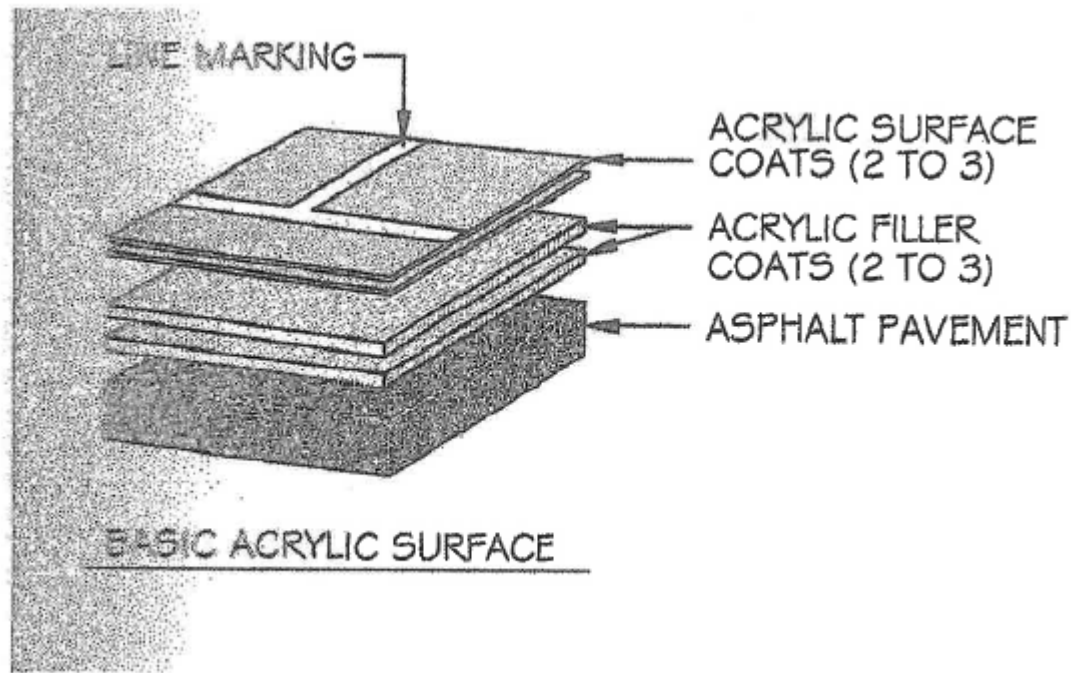

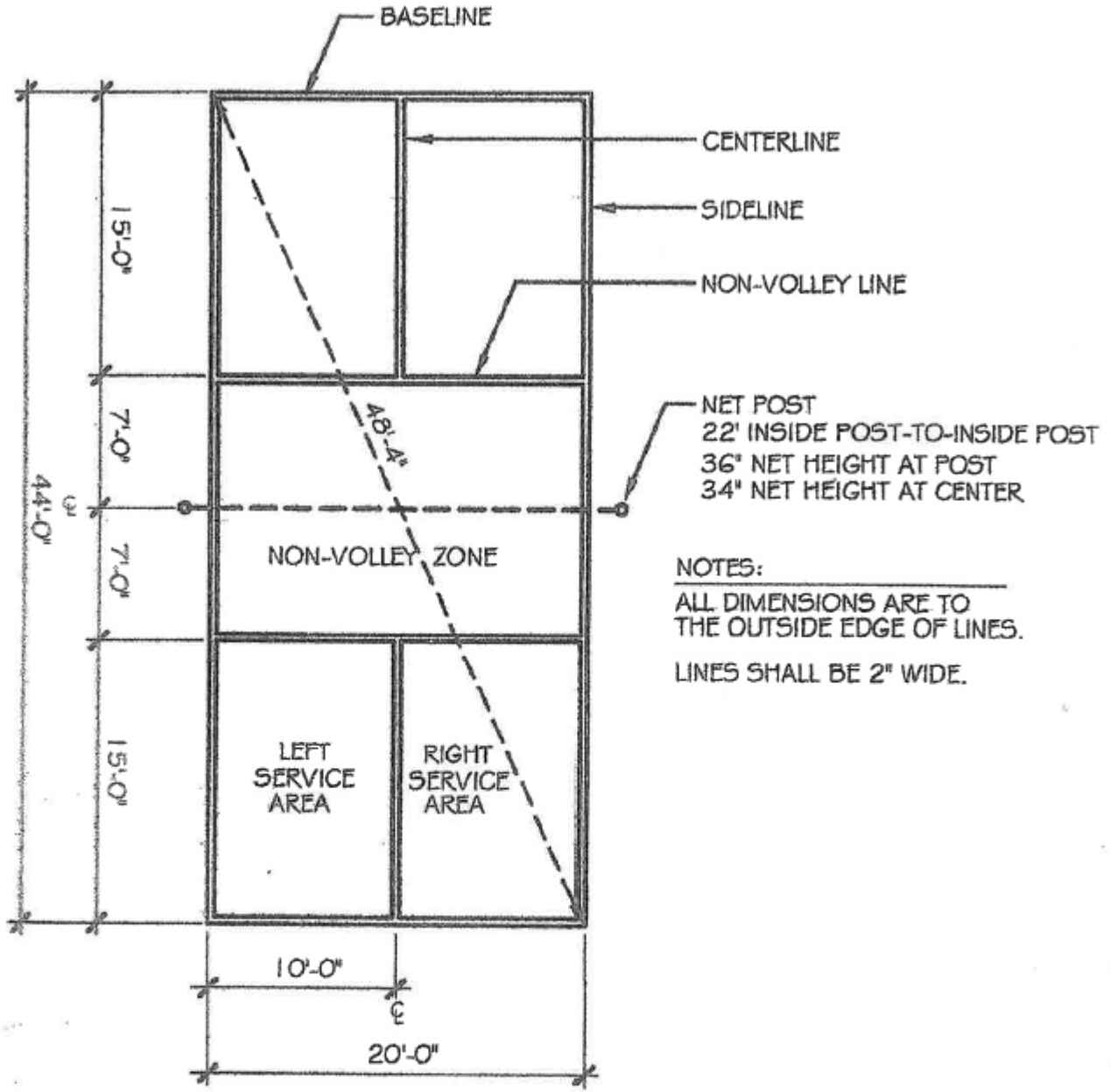

LINE TOLERANCE GUIDE:

NET LINE TO OUTSIDE OF NVZ LINE:	7'-0"	+/- 1/8"
NET LINE TO OUTSIDE OF BASELINE:	22'-0"	+/- 1/4"
OUTSIDE SIDELINE TO OUTSIDE SIDELINE:	20'-0"	+/- 1/4"
OUTSIDE SIDELINE TO CENTERLINE:	10'-0"	+/- 1/8"
DIAGONAL DIMENSION:	48'-4"	+/- 3/4"

COURT - PLAYING LINE LAYOUT

NOT TO SCALE