

Proposal for
Lynden Parks & Recreation

Prepared by



09-04-2024
Job # 11867-01

Schoolyard Park Playground Option 3



435-901-9544 | www.gwpark.com

**Schoolyard Park Playground Option 3 - Project 111867-01-Opt 3
Lynden, WA**



**Schoolyard Park Playground Option 3 - Project 111867-01-Opt 3
Lynden, WA**



**Schoolyard Park Playground Option 3 - Project 111867-01-Opt 3
Lynden, WA**



**Schoolyard Park Playground Option 3 - Project 111867-01-Opt 3
Lynden, WA**



Schoolyard Park Playground Option 3 - Project 111867-01-Opt 3
Lynden, WA



**Schoolyard Park Playground Option 3 - Project 111867-01-Opt 3
Lynden, WA**



**Schoolyard Park Playground Option 3 - Project 111867-01-Opt 3
Lynden, WA**



**Schoolyard Park Playground Option 3 - Project 111867-01-Opt 3
Lynden, WA**



**Schoolyard Park Playground Option 3 - Project 111867-01-Opt 3
Lynden, WA**



**Schoolyard Park Playground Option 3 - Project 111867-01-Opt 3
Lynden, WA**



**Schoolyard Park Playground Option 3 - Project 111867-01-Opt 3
Lynden, WA**



**Schoolyard Park Playground Option 3 - Project 111867-01-Opt 3
Lynden, WA**

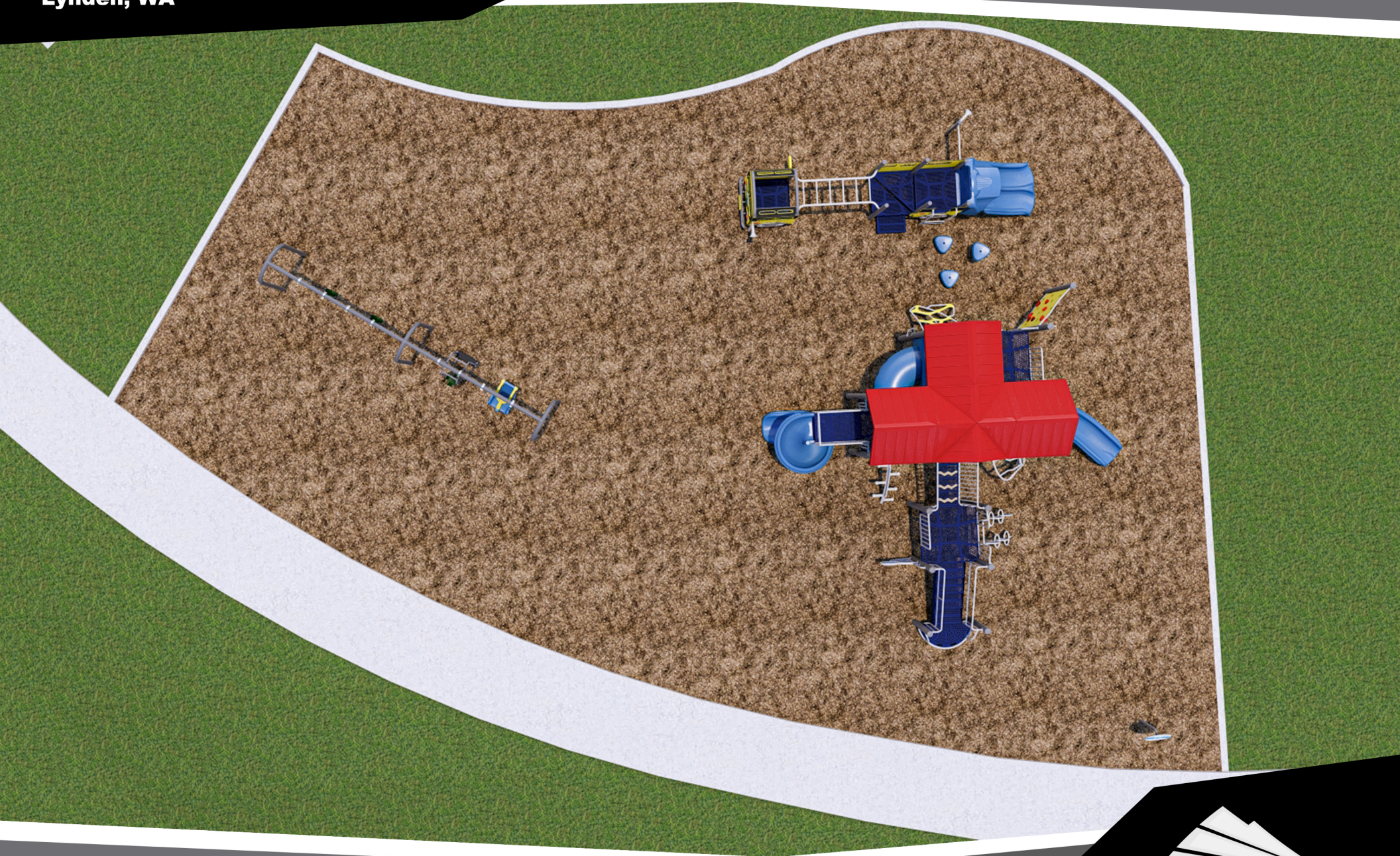

AREA:
SF: 3,290
LF: 235
100 LF Curb

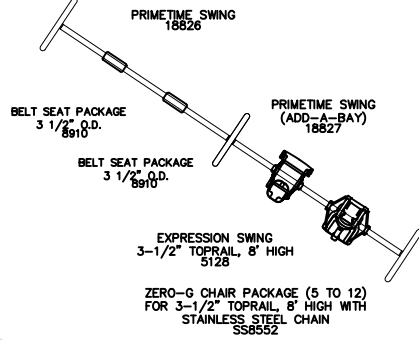

86'-9"

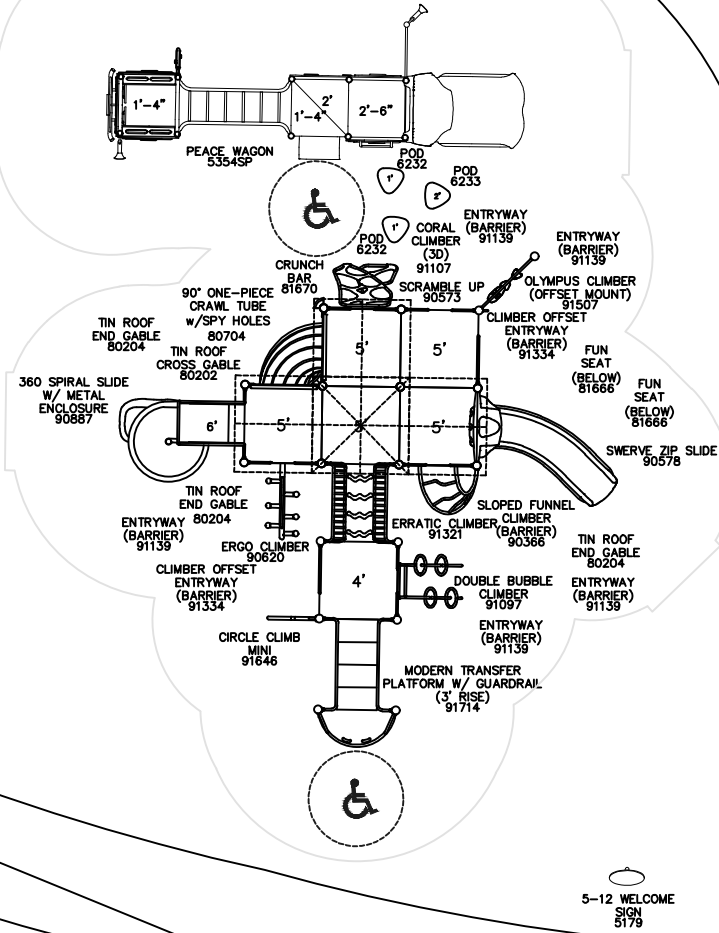

43'-7"

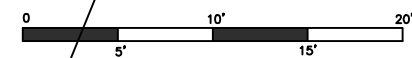

City of Lynden
Schoolyard Park
Lynden, WA
Representative
Great Western Recreation

SALES REP
QUINN CONNELL
435-901-9544
QUINN@GWPARK.COM

Total Elevated Play Components	11	-	-
Total Elevated Play Components Accessible By Ramp	-	Required	-
Total Elevated Components Accessible By Transfer	10	Required	6
Total Accessible Ground Level Components Shown	10	Required	4
Total Different Types Of Ground Level Components	6	Required	3

This play equipment is recommended for children ages
5-12

Minimum Area Required:
Scale: -
This drawing can be scaled only when in an 18" x 24" format

IMPORTANT: Soft resilient surfacing should be placed in the use zones of all equipment, as specified for each type of equipment, and at depths to meet the critical fall heights as specified by the U.S. consumer Product Safety Commission, ASTM standard F 1487 and Canadian Standard CAN/CSA-Z-614

Drawn By:
LC
Date:
08/29/2024
Drawing Name:
111867-01 Option 3

CUSTOM COLOR SELECTIONS

Approved by: _____

Project: 111867-01-Opt 3

Surfacing:

CUSTOM COLORS:

ITEM	COLOR	ITEM	COLOR	ITEM	COLOR	ITEM	COLOR
<input type="radio"/> BASIC	<input type="radio"/> ACCENT/ARCH	<input type="radio"/> METAL ROOF	<input type="radio"/> ROTO	<input type="radio"/> TUBE	<input checked="" type="radio"/> PLASTIC ROOF	<input type="radio"/> HDPE	<input type="radio"/> 2 COLOR HDPE
<input type="radio"/> SHADE							

<input type="radio"/> Charcoal	<input type="radio"/> Silver	<input type="radio"/> Cream	<input type="radio"/> Beige	<input type="radio"/> Light	<input type="radio"/> Cedar	<input type="radio"/> Brown	<input type="radio"/> Forest Green	<input type="radio"/> Bottle Green	<input type="radio"/> Lime	<input type="radio"/> Dove Blue	<input type="radio"/> Turquoise	<input type="radio"/> True Blue	<input type="radio"/> Navy Blue	<input type="radio"/> Purple	<input type="radio"/> Royal Purple	<input type="radio"/> Deep Ochre	<input type="radio"/> Sun Blaze	<input type="radio"/> Cayenne	<input type="radio"/> Orange	<input type="radio"/> Yellow
--------------------------------	------------------------------	-----------------------------	-----------------------------	-----------------------------	-----------------------------	-----------------------------	------------------------------------	------------------------------------	----------------------------	---------------------------------	---------------------------------	---------------------------------	---------------------------------	------------------------------	------------------------------------	----------------------------------	---------------------------------	-------------------------------	------------------------------	------------------------------

DECKS

<input type="radio"/>	<input type="radio"/>	<input type="radio"/>	<input type="radio"/>
<input checked="" type="radio"/> Blue	<input type="radio"/> Brown	<input type="radio"/> Chocolate	<input type="radio"/> Gray

HANDGRIP

PRIMARY
NATURAL

<input type="radio"/> Red	<input type="radio"/> Green	<input type="radio"/> Blue	<input type="radio"/> Beige

RECYCLED LUMBER

<input type="radio"/>	<input type="radio"/>	<input type="radio"/>
<input type="radio"/> Gray	<input type="radio"/> Tudor	<input type="radio"/> Sand

ROCK

<input type="radio"/>	<input checked="" type="radio"/>
<input type="radio"/> Sandstone	<input checked="" type="radio"/> Deep Granite

Standard Colors

VISTAROPE

Custom Colors

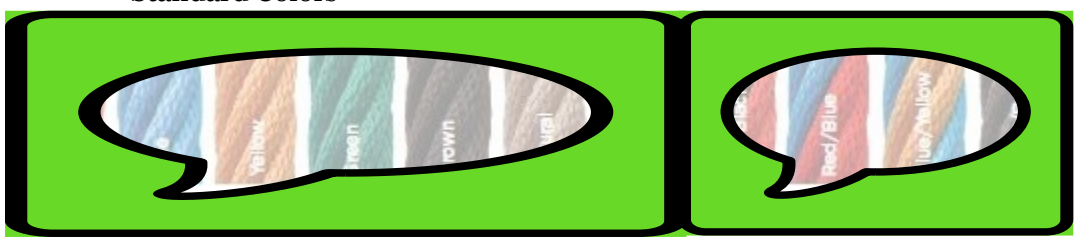



GameTime C/O Great Western Recreation
 P.O. Box 680121
 Fort Payne, AL 35967
 Office: 435-245-5055 Fax: 435-245-5057
 www.gwpark.com

09/04/2024
 Quote #
 111867-01-03

Schoolyard Park Playground Option 3 - Fall Grant

Lynden Parks & Recreation
 Attn: Brent De Ruyter
 8770 Bender Rd.
 Lynden, WA 98264
 United States
 Phone: 360-354-6717
 deruyterb@lyndenwa.org

Ship to Zip 98264

Qty	Part #	Description	List \$	Selling \$	Ext. Selling \$
1	RDU	GameTime - Custom 5-12 Play Structure- Reference drawing #111867-01 Option 3	\$76,626.00	\$46,440.13	\$46,440.13
1	5354SP	GameTime - Peace Wagon 2	\$26,644.00	\$26,644.00	\$26,644.00
1	RDU	GameTime - Swings- Reference drawing #111867-01 Option 3	\$6,648.00	\$6,069.01	\$6,069.01
1	5179	GameTime - Welcome Sign (5-12)	\$748.00	\$703.12	\$703.12
				Sub Total	\$79,856.26
				Estimated Freight	\$7,758.94
				Tax	\$7,885.37
				Total	\$95,500.57

Comments

Your Sales Rep is Quinn Connell. Please reach out to Quinn at 435-901-9544 if you should have any questions regarding this quote.

***Pricing is based on Grant 2024 pricing. Orders MUST be placed before October 25, 2024, and MUST be shipped by December 31, 2024 to qualify for Grant Pricing.

***Not all equipment is eligible for Grant Pricing.

Due to the volatility of freight costs, the freight pricing is subject to change at the time of order.

Pricing is subject to change. Request updated pricing when purchasing from quotes more than 30 days old.

Shipping to:
 8770 Bender Rd.
 Lynden, WA 98264

Site address:
 622 Glenning St.
 Lynden, WA 98264

*Freight charges are based on listed zip code and are subject to change if shipping information changes.

Permitting not included, unless otherwise noted.

Customer is responsible for offloading.

Install not included.





GameTime C/O Great Western Recreation
P.O. Box 680121
Fort Payne, AL 35967
Office: 435-245-5055 Fax: 435-245-5057
www.gwpark.com

09/04/2024
Quote #
111867-01-03

Schoolyard Park Playground Option 3 - Fall Grant

Remit Payment to:

GameTime
P.O. Box 680121
Fort Payne, AL 35968

Taxes:

All applicable taxes will be added at time of invoicing unless otherwise included or a tax-exempt certificate is provided. If sales tax exempt, you must provide a copy of certificate to be considered exempt.

Prices:

FOB Factory.

Orders:

All orders shall be in writing by purchase order, contract, or similar document made out to PlayCore Wisconsin Inc., dba GameTime. Standard GameTime equipment orders over \$100,000 may require a deposit of 25% at the time of order and an additional 25% at or before order ships. Standard orders with equipment, installation and surfacing are requested to be split billed. Equipment, Taxes & Freight as noted above. Installation and Surfacing billed as completed and Due Upon Receipt.

Terms:

Cash With Order Discount (CWO): Orders for GameTime equipment paid in full at time of order via check, Electronic Funds Transfer (ACH or wire) are eligible for a three percent (3%) cash with order discount.

Payment via credit card: If you elect to pay by credit card, GameTime charges a 2.50% processing fee that is assessed on the amount of your payment. This fee is shown as a separate line item and included in the total amount charged to your credit card. You have the option to pay by check, ACH or Wire without any additional fees.

Credit terms are Net 30 days, subject to approval by the GameTime Credit Manager. A completed credit application must be submitted and approved prior to the order being received. Please allow at minimum 2 days for the credit review process. GameTime may also require:

Completed Project Information Sheet (if applicable)

Copies of Payment and Performance Bonds (if applicable)

A 1.5% per month finance charge will be imposed on all past due invoices.

Retainage not accepted.

Orders under \$5,000 require payment with order.

Landmark Design GFRC:

Orders require a 50% deposit at the time of order.

SUPPLY ONLY:

- All items are quoted supply only.
- Installation services are not included.
- Customer is responsible for coordinating delivery, receipt, unloading, and inventory equipment.
- Missing or damaged equipment must be reported within 60 days of delivery.





GameTime C/O Great Western Recreation
P.O. Box 680121
Fort Payne, AL 35967
Office: 435-245-5055 Fax: 435-245-5057
www.gwpark.com

09/04/2024
Quote #
111867-01-03

Schoolyard Park Playground Option 3 - Fall Grant

ACCEPTANCE OF QUOTATION:

Acceptance of this proposal indicates your agreement to the terms and conditions stated herein.

Purchase Amount: **\$95,500.57** Date: _____

Signature

Please fill out this [ORDER FORM](#), this is required to process the order.

