



## Staff Report

**To:** Mayor and City Council

**Through:** Danny Roberts, City Manager

**From:** Jeremy Armistead, Public Works Department Director

**Date:** July 29, 2024

**Subject:** Purchase of (1) Wanco Full Matrix Message Board and (2) Wanco 30ft. Light Towers

**RECOMMENDATION:**

Staff recommends that Loganville City Council approve the purchase of (1) Wanco Full Matrix Message Board. This is a towable message board that will be used to alert the public of any useful information such as road closings and traffic delays. It may also be used to notify the public of any other information the city may deem necessary such as event info and the like. Total cost for this item will be \$19,230.00.

Secondly the staff recommends the Loganville City Council approve the purchase (2) Wanco Laydown Light Towers. These are 30ft. light towers that can be used when any city department is working at night and there is not enough light on the job site. These light towers will be used to replace (2) older light towers that have been in service for over 10 years and are currently being stored at the Utilities Department. The 2 older light towers will be used as backups whenever such a need arises. Total combined cost of both light towers is \$29,347.50.

After contacting several vendors trying to obtain quotes for these items only (2) vendors returned quotes. They are included with this packet for further information.

**FINANCIAL IMPLICATION:**

These items upon approval will be funded using ARPA funds



# Quote

DBA



Date	Quote #
7/17/2024	29084

Name / Address
City of Loganville PO Box 39 Loganville, GA 30052 jarmistead@loganville-ga.gov

Ship To
City of Loganville 4303 Lawrenceville Road Loganville, GA 30052

Customer Phone	Project/Job Reference	Customer Cell Phone	Customer E-mail
770-466-0902			jarmistead@loganville-ga.gov

Terms	Quoted To	Quote valid thru	Rep	CSR	FOB
Net 30	Jeremy	8/16/2024	KMorg	KM	Origin

Item	Description	Qty	U/M	Unit Price	Total
WTMMBA*	WANCO - WTMMB(A) (Base Model) - Wanco Full Size Matrix Message Board with Hydraulic Lift (Display Size: 75" x 138") Full matrix display • 18" default font size, variable font sizes, full range of MUTCD graphics • One 130-watt solar panel • Four 6 volt Deep Cycle batteries, 400 Ah total capacity • 15 amp charger • Telescoping hydraulic tower with 360-degree rotation • Internal Touch-screen Sign Controller • Orange powder-coat finish • 2" Ball hitch • Removable draw bar • Galvanized swivel base and tower • High Density Polyethylene Fenders	1	ea	18,480.00	18,480.00T
Freight - DS-C	Freight - DS - Customer	1		750.00	750.00
	At this time, expect Delivery within 30 business days or less from time of order.				
	Total Sales Tax Calculated by Avatax			0.00%	0.00

				<b>Total</b>	<b>\$19,230.00</b>
--	--	--	--	--------------	--------------------

# The safest means for notifying motorists of changes in traffic patterns and road conditions.

Wanco Message Signs are the ideal choice when you need to get information to the public. Full-size signs provide versatility and great performance.

Full-matrix signs provide the greatest flexibility for displaying any type of message—large or small letters, symbols, graphics. Graphics and text can be combined in the same message.

Three-line message signs are capable of displaying three rows of alphanumeric characters. The ultra-bright, highly legible LEDs display your message clearly.

Changing the message is simple, as Wanco signs feature the easiest programming in the industry. The in-cabinet controller has a 7-inch LCD capacitive touchscreen.

Signs come configured with preprogrammed standard messages. Multiple programming options provide flexibility for multiple applications.

Unsurpassed quality, engineering and value, paired with a multitude of functions and options, make these signs perfect for a wide variety of applications.

**Meets NEMA TS 4-2005 Section 2 for ambient temperature, vibration, shock, electro-static discharge (ESD), and radio interference.**

Dimensions in *Inches*  
(*cm*)

## Travel position

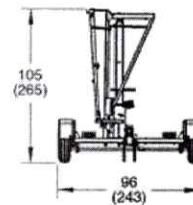
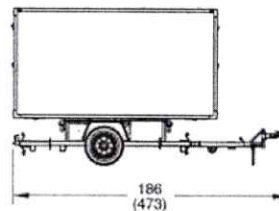

## Deployed

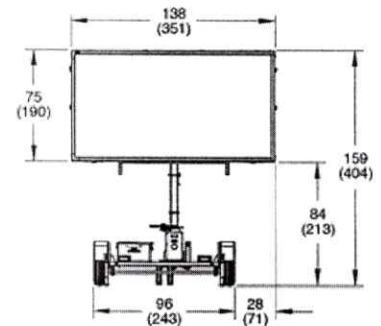
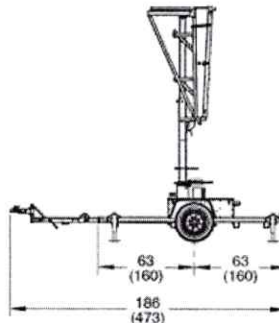

Weight Approx. 2640 lbs. (1193 kg)  
Tires ST205/75 D15

## Matrix Signs

WTMMB(A) Hydraulic lift  
WTMMB(B) Manual winch

### Display

Resolution Four amber LEDs form each pixel  
Matrix 48 pixels wide, 27 pixels high  
Fonts 12 fonts, selectable  
Default font 5 x 7 pixels  
3 lines of 8 characters max.  
Default font size 11 x 16 in. (28 x 42 cm)

### Power

Batteries Four 6 Vdc deep-cycle batteries wired for 12 Vdc power  
Battery capacity 430 Ah total capacity @ 12 Vdc  
Solar panels 130 W minimum  
Power options Additional batteries, 4D AGM batteries and solar panels

## Three-Line Signs

WTLMB(A) Hydraulic lift  
WTLMB(B) Manual winch

### Display

Resolution Four amber LEDs form each pixel  
Font 1 font  
5 x 7 pixels  
3 lines of 8 characters per line max.  
Font size 12 x 18 in. (30 x 45 cm)

### Power

Batteries Four 6 Vdc deep-cycle batteries wired for 12 Vdc power  
Battery capacity 430 Ah total capacity @ 12 Vdc  
Solar panels 130 W minimum  
Power options Additional batteries, 4D AGM batteries and solar panels

Due to Wanco's commitment to continuous improvement of our products, all information is subject to change without notice. Wanco and the Wanco logo are registered trademarks of Wanco Inc. All other trademarks are property of their respective owners.

©2016 Wanco Inc. All rights reserved. | WPB0058 October 2016



LAWRENCEVILLE, GA  
770.962.2222

**Rental Pump Parts, LLC**  
 608 Holcombe Ave  
 Mobile, AL 36606 US  
 251-222-3897  
 service@rentalpumpparts.com  
 www.rentalpumpparts.com



**ADDRESS**  
 Jeremy Armistead  
 City of Loganville  
 PO Box 39  
 Loganville, GA 30052

**SHIP TO**  
 Jeremy Armistead  
 City of Loganville  
 PO Box 39  
 Loganville, GA 30052

**Estimate 1238**

**DATE 06/27/2024**

**SHIP DATE**  
 09/27/2024

**SHIP VIA**  
 BW

DATE	ACTIVITY	DESCRIPTION	QTY	RATE	AMOUNT
	<b>TC1-ADS</b>	Trailer Mounted Dynamic Sign, Battery Powered, Standard Yellow/Orange Lighting	1	22,500.00	22,500.00

90 day lead time on towable units.  
 HubZone 73244  
<https://www.trafcon.com/products/message-boards/trailer-mounted/tc1-ads>

<b>SUBTOTAL</b>	22,500.00
<b>TAX</b>	0.00
<b>SHIPPING</b>	1,500.00

**TOTAL \$24,000.00**

Accepted By

Accepted Date

[Select Page](#)[Home](#) » [Products](#) » [Message Boards](#) » [Trailer Mounted](#) » [TC1-ADS](#)

## TC1-ADS – TRAILER MOUNTED DYNAMIC SIGN

TRAFCON's TC1-ADS PCMS signs can be configured as 5x2, 6x2 or 4x3. As needs change, BRICKs can be added or removed. A durable, all-steel trailer and energy-efficient solar power complete this unique, high-performance package.

**All TRAFCON trailers are built with NATM Approved Compliance**

### **Arrow Dynamic Sign® (ADS) Features**

The Arrow Dynamic Sign® (ADS) combines the positive attributes of both an arrow board and a dynamic message sign. You can combine the clarity of a text message with the impact of graphics message. The convenience and flexibility enable the user to program the sign to fit various applications.

**See Product and Custom Applications Below...**

## SOLAR CHARGING SYSTEM

- ADS utilizes the modular BRICK® system
- Sealed display modules eliminate bulky poly face doors
- The only display modules in the industry to meet SAE J1455 salt spray requirements
- Bright, long-lasting LED's, superior angularity
- Signs can be configured to meet size and budget requirements
- Full matrix graphics and text can be programmed utilizing a laptop computer or handheld terminal
- System meets or exceeds all industry and government standards for both changeable message signs and arrow boards
- Microprocessor based controller
- Non-volatile memory stores up to 200 sequences
- Fully automatic 110v/12v battery charger included
- Rugged polyethylene low-density box and fenders
- 1 screw jack on tongue and 4 corner drop jacks
- Wide wheelbase trailer for towing stability
- 14" wheels and tires
- Durable powder coat finish
- Heavy Duty "A" frame drawbar
- LCD, backlighted, touchpad control
- Single Crystal solar panels provide higher performance



## Contact our Sales Team now!

To learn more about our products or place an order, call (717)-691-8007 or email [sales@trafcon.com](mailto:sales@trafcon.com)

## Contact Us



# Quote

DBA



Date	Quote #
7/17/2024	29082

Name / Address
City of Loganville PO Box 39 Loganville, GA 30052 jarmistead@loganville-ga.gov

Ship To
City of Loganville 4303 Lawrenceville Road Loganville, GA 30052

Customer Phone	Project/Job Reference	Customer Cell Phone	Customer E-mail
770-466-0902			jarmistead@loganville-ga.gov

Terms	Quoted To	Quote valid thru	Rep	CSR	FOB
Net 30	Jeremy	8/16/2024	KMorg	KM	Origin

Item	Description	Qty	U/M	Unit Price	Total
25-67NI*	Wanco Standard Diesel Laydown Light Tower with Kubota D1005 Engine and 6kW Generator Four 1000-watt metal halide lamps - Fully adjustable high-efficiency light fixtures - 30-foot telescoping tower rotates 360 degrees - Dual hand-operated winches for raising and lowering tower - 1800 RPM Tier 4 Final diesel engine - Mecc Alte brushless four-pole generator - 30-gallon fuel tank - 120V AC Duplex GFCI - 12V Group24 start battery - Powder-coat finish - Compact trailer with leaf spring axle - Gull-wing doors and hinged in panel for engine access - Combination hitch for 2.5-inch pintle hook and 2-inch ball hitch	2	ea	10,925.00	21,850.00T
25-67NI*	(4) 480W LED Floodlights. 57,800 lm per fixture, 231,200 lm total. Fuel consumption 0.31 gal/hr. Approximately 190 hrs between refueling.	2	ea	3,248.75	6,497.50T
Freight	Freight	1		1,000.00	1,000.00

<b>Total</b>
--------------



# Quote

DBA



Date	Quote #
7/17/2024	29082

Name / Address
City of Loganville PO Box 39 Loganville, GA 30052 jarmistead@loganville-ga.gov

Ship To
City of Loganville 4303 Lawrenceville Road Loganville, GA 30052

Customer Phone	Project/Job Reference	Customer Cell Phone	Customer E-mail
770-466-0902			jarmistead@loganville-ga.gov

Terms	Quoted To	Quote valid thru	Rep	CSR	FOB
Net 30	Jeremy	8/16/2024	KMorg	KM	Origin

Item	Description	Qty	U/M	Unit Price	Total
	At this time, Delivery 30 business days from date of order Client MUST have loading dock or forklift with 8' forks in order to offload equipment.  If Loganville does not have the requirements, they can be picked up at Transafe				
	Total Sales Tax Calculated by Avatax			0.00	0.00
	Total Sales Tax Calculated by Avatax			0.00%	0.00

	<b>Total</b>	<b>\$29,347.50</b>
--	--------------	--------------------



# Robust and reliable with unique features for enhanced performance

- High-output light fixtures
- Telescoping tower rotates nearly 360 degrees
- Multiple low-speed engine options
- Heavy gauge all-steel body
- Unobstructed engine accessibility



Not just another light tower, Wanco Laydown Light Towers use state-of-the-art technology for superior illumination, shining a uniform light pattern across the entire job site and exceeding government regulations for worksite illumination.

For fast job-site setup and less downtime, each light fixture can be aimed independently without the use of tools—and the fixtures stay in place once positioned. Choose either LED or metal halide lights when specifying your light tower. Wanco's proprietary LED fixtures are the brightest available on any portable light tower, and Wanco's metal halide fixtures feature high-intensity parabolic reflectors that increase illumination. Balloon lights are also available.

The telescoping tower stows securely in a travel cradle when it is horizontal, then extends vertically to 30 feet when deployed. While upright, the tower rotates nearly 360 degrees and the lights operate at any height, eliminating the need to move the trailer frequently. Two winches raise and extend the tower easily. Manual winches are standard and power winches are optional.

A choice of industrial diesel engines and four-pole generators ensure reliable performance. The high-efficiency engine and 30-gallon fuel tank provide extended run times between refuelings—up to 120 hours with Wanco's exclusive LED light fixtures. Performance enhancing options include an automated dusk-to-dawn start/stop system and cold-weather start package.

For system maintenance, Wanco's exclusive hinged top panel provides unimpeded access to the engine, generator and electrical components. The equipment bay is a rugged all-steel cabinet with gull-wing doors that can be locked closed to protect against unauthorized access.

Wanco Laydown Light Towers boast trouble-free performance and exceptional longevity—hallmarks of the Wanco brand.

To order one today, call **800.972.0755** or visit [wanco.com](http://wanco.com).

## Brief specifications

### Physical

Deployed footprint	127 × 112 in. (321 × 285 cm), L × W
Operating height	Max. 30 ft (9.14m) Min. 12½ ft (3.81m)
Travel height	66 in (168cm)
Weight	Operating Approx. 1800 lb (815kg) Shipping Approx. 1550 lb (703kg)

### Lights

	480-watt LEDs	350-watt LEDs	Metal halides
Lamps*	Four 480W fixtures	Four 350W fixtures	Four 1000W lamps
Luminosity**	57,800 lm per fixture 231,200 lm total	49,000 lm per fixture 196,000 lm total	110,000 lm per lamp 440,000 lm total

### Power system

Engine type	Tier 4 Final diesel, 3-cylinder, 4-cycle
Engine speed*	1800 rpm @ 60 Hz or 1500 rpm @ 50Hz
Generator type	Brushless, class H
Sound level	71 dB @ 23 ft (7m) at max. load
Battery	12 Vdc, 550 CCA

	Kubota® D1005	Mitsubishi® L3E	Kohler® KD1003
Maximum power output*	13.1 hp (9.8 kW)	15.4 hp (11.5 kW)	23.7 hp (17.7 kW)
Displacement*	61.08 in³ (1001cm³)	68.53 in³ (1123cm³)	62.7 in³ (1028cm³)
Fuel tank capacity	30 gal (114L)	30 gal (114L)	30 gal (114L)
Fuel consumption*	0.31 gal/hr (1.17L/h)	0.25 gal/hr (0.096L/h)	0.49 gal/hr (1.86L/h)
Runtime before refueling*	Approx. 97 hrs	Approx. 120 hrs	Approx. 62 hrs

### Output power

Output*	6 kW or 8 kW
Voltage*	120 Vac or 240 Vac
Amperage	50 A @ 120V, 25 A @ 240V
Frequency*	60 Hz or 50 Hz
Voltage regulation	±6%, no load to full load

\*Depending on model \*\*Continuous intensity for LEDs, initial intensity for metal halides



**WANCO INC.**  
5870 Tennyson Street  
Arvada, Colorado 80003 USA  
800-972-0755  
303-427-5700  
303-427-5725 fax  
[www.wanco.com](http://www.wanco.com)

Due to Wanco's commitment to continuous improvement of our products, all information is subject to change without notice. Wanco and the Wanco logo are registered trademarks of Wanco Inc. All other trademarks are property of their respective owners.

©2019 Wanco Inc. All rights reserved. Printed in the USA. | WPB0012 November 2019

Printed on recycled paper

Rental Pump Parts, LLC  
608 Holcombe Ave  
Mobile, AL 36606 US  
251-222-3897  
service@rentalpumpparts.c  
om  
www.rentalpumpparts.com



**ADDRESS**  
Jeremy Armistead  
City of Loganville  
PO Box 39  
Loganville, GA 30052

**SHIP TO**  
Jeremy Armistead  
City of Loganville  
PO Box 39  
Loganville, GA 30052

Estimate 1237

DATE 06/27/2024

**SHIP DATE**  
08/15/2024

**SHIP VIA**  
BW

DATE	ACTIVITY	DESCRIPTION	QTY	RATE	AMOUNT
	HiLight V5+	AC 4 Light LED Trailer Mounted Diesel Light Tower	2	13,125.00	26,250.00

LED Light Towers are scheduled to arrive in US around the end of July beginning of August. HUBZone Number 73244	<b>SUBTOTAL</b>	26,250.00
	<b>TAX</b>	0.00
	<b>SHIPPING</b>	1,000.00
	<b>TOTAL</b>	<b>\$27,250.00</b>

Accepted By

Accepted Date

		BATTERY			DIESEL			ELECTRIC		
		HiLight Z3+	HiLight B5+	HiLight V5+ S	HiLight V4 S	HiLight V4W	HiLight E3+	HiLight P2+	HiLight V2+   V3+	
Light coverage ft <sup>2</sup>		32,292 (average 10 luxes)	53,819 (average 20 luxes)	53,819 (average 20 luxes)	43,055 (average 20 luxes)	43,055 (average 20 luxes)	32,292 (average 10 luxes)	21,527 (average 10 luxes)	21,527 (average 10 luxes)	
Lamps		LED	LED	LED	Metal halide	Metal halide	LED	LED	LED	
Mast		Vertical Hydraulic Battery Powered Noise & CO <sub>2</sub> free	Vertical Hydraulic	Vertical manual	Vertical manual	Vertical manual	Vertical manual	Vertical manual	Vertical manual	
Features			Compact box	HardHat® canopy	HardHat® canopy	HardHat® canopy	Electric	Electric	Electric	
<b>Performance data</b>										
Rated frequency	Hz	60	60	60	60	60	60	60	60	
Rated voltage	VAC	120	120	120	120	120-240	120	120	120	
Rated power (PRP)	kW	-	2.7	2.7	6.8	8	-	-	-	
Operating temperature (min/max)	°F (°C)	-4/ 122 (-20/ 50)	-4/ 104 (-20/ 40)	-13 / 122 (-25 / 50)	-13 / 122 (-25 / 50)	-13 / 122 (-25 / 50)	-	-	-	
Sound power level (LwA)	dB(A)	-	82	86	94	89	-	-	-	
Sound pressure level (LpA) at 7m	dB(A)	-	55	63	73	64	-	-	-	
<b>Engine</b>										
Model		-	Kubota Z481	Kubota Z482	Kubota Z482	Kubota D1105	-	-	-	
Speed	rpm	-	1800	1800	3600	1800	-	-	-	
Rated net output (PRP)	kW	-	3	3	8.1	10	-	-	-	
Coolant		-	Water	Water	Water	Water	-	-	-	
Number of cylinders		-	1	2	2	3	-	-	-	
<b>Alternator</b>										
Model		-	Meccalte LT3/74	Meccalte LT3/75	Sincro EK 2 MCT	DP06/AG164	-	-	-	
Rated output	kVA	-	3.5	4.5	7.5	8	-	-	-	
Insulation / Enclosure protection	class / IP	-	H / 20	H / 21	H / 23	H / 23	-	-	-	
<b>Fuel consumption</b>										
Fuel tank capacity	gallon (l)	-	34.3 (230)	28 (105)	28 (105)	42 (160)	-	-	-	
Autonomy	h	18-32	220	150	50	90	-	-	-	
<b>Power output</b>										
Auxiliary Power	W	-	1,200	1,200	2,400	7,200	-	-	-	
Outlets		-	120 VAC, 10A, GFCI Duplex (NEMA 5-20R)	120 VAC, 10A, GFCI Duplex (NEMA 5-20R)	120 VAC, 20A, GFCI Duplex (NEMA 5-20R)	121 VAC, 20A, GFCI Duplex (NEMA 5-20R) 240VAC, 30A, TL (NEMA L5-30R)	-	-	-	
<b>Lights</b>										
Floodlights		LED	LED	LED	Metal halide	Metal halide	LED	LED	LED	
Wattage	W	4x 160	4x 350	4x 350	4x 1,000	4x 1,000	4x 160	320	320   4 x 120	
Luminous Flux	Lumen	4 x 16,000	4 x 38,500	4 x 38,500	4 x 110,000	4 x 110,000	4 x 16,000	28,000	28,000   4 x 12,000	
<b>Mast</b>										
Type		Hydraulic, vertical, 5 section	Hydraulic, vertical, 5 section	Manual vertical, 5 section	Manual vertical, 5 section	Manual vertical, 5 section	Manual	Manual	Manual	
Rotation	degrees	340	340	360	360	360	0	0	0	
Maximum height	ft (m)	26 (7.9)	26 (7.9)	25 (7.5)	25 (7.5)	25 (7.5)	23 (7)	11 (3.4)	17 (5)	
Maximum speed wind	mph (kph)	50 (80)	50 (80)	51 (80)	51 (80)	59 (95)	52 (80)	32(50)	32 (50)	
<b>Enclosure and trailer</b>										
Type		Box type Forklift pockets	Box type Forklift pockets	DOT US Compliant Unibody trailer with 4 point leveling system	DOT US Compliant Unibody trailer with 4 point leveling system	DOT US Compliant Unibody trailer with 4 point leveling system	-	-	Trailer with Bumpers in PE	
Base Frame		-	Spillage free frame	Spillage free frame	Spillage free frame	Spillage free frame	-	-	-	
Enclosure		Galvanneal Steel Canopy & Powder coating painting	Galvanneal Steel Canopy & Powder coating painting	Gull-wing Hard Hat Doors	Gull-wing Hard Hat Doors	Gull-wing Hard Hat Doors	Hard Hat Canopy	-	-	
<b>Dimensions and weight</b>										
Dimensions in transport Up-right Towbar (L x W x H)	in (m)	-	-	77 x 48 x 102 (1.95 x 1.22 x 2.59)	77 x 48 x 102 (1.95 x 1.22 x 2.59)	74 x 53 x 98 (1.88 x 1.34 x 2.49)	-	-	-	
Dimensions in transport Towed (L x W x H)	in (m)	46 x 46 x 97 (1.16x 1.16x 2.46)	46 x 46 x 97 (1.16x 1.16x 2.46)	110 x 48 x 102 (2.79 x 1.22 x 2.59)	110 x 48 x 102 (2.79 x 1.22 x 2.59)	110 x 53 x 98 (2.79 x 1.34 x 2.49)	48 x 32 x 84 (1.2 x 0.8 x 2.14)	19.7 x 19.7 x 87 (0.5 x 0.5 x 2.2)	45 x 335 x 79 (1.1 x 0.85 x 2)	
Weight	lb (kg)	2160 (980)	2160 (980)	1,768 (802)	1,970 (894)	2,041 (926)	608 (276)	99 (45)	243 (110)	