

*where people matter*

City of Loganville

Public Utilities  
Brandon Phillips  
Director

P.O. Box 39  
Loganville, GA 30052

Tel: 770-466-3240

## Staff Report Department of Public Utilities

**To:** Honorable Mayor Baliles and Members of the City Council

**Through:** Danny Roberts, City Manager

**From:** Brandon Phillips, Director of Utilities

**Date:** May 9, 2024

**Subject:** The Purchase of a Sound Proof Building with ARPA Funds

### **RECOMMENDATION:**

Public Utilities staff is requesting that the City Council authorize the approval to purchase a building from Cornerstone Mechanical.

### **FISCAL IMPLICATION:**

The Utility Department is requesting the purchase of this enclosure to sound proof the blowers at the septic hauler dumping station. This purchase will be funded by ARPA totaling \$23,880.21.

### **BACKGROUND:**

The Wastewater Treatment Facility has two new blowers that control the aeration in the septic haulers dumping basin. These new blowers are extremely noisy, and we have received complaints from local residents. This sound proof enclosure is designed for this application, and has removable panels on the sides and roof that will allow for maintenance. We are currently only operating the blowers during normal business hours, and this will also allow our staff to operate the blowers 24 hours a day and improve the aeration.

**Cornerstone Mechanical**  
 PO Box 3095  
 Peachtree City, GA 30269  
 (770) 742-3321  
 jessie@cornerstoneh2o.com  
 https://www.cornerstone-mechanical.com



## Estimate

**ADDRESS**

City of Loganville  
 4303 Lawrenceville Rd  
 Loganville, GA 30052

**SHIP TO**

City of Loganville WWTP  
 4895 Hwy. 81 N  
 Loganville, GA 30052  
 Attn: Mike McDaniel

**ESTIMATE # 1161**

**DATE** 04/16/2024  
**EXPIRATION DATE** 05/16/2024

ACTIVITY	DESCRIPTION	QTY	RATE	AMOUNT
<b>Field Services</b>	Sound Attenuation Structure for Blowers 1. United Blower is offering to design, build, and install a sound enclosure of the 2" thickness removeable panel design, to surround two 50HP blowers at Loganville WWTP. 2. On the outlet end, the enclosure will extend past the end of the pad in order to incorporate the full equipment skid. 3. The estimated enclosure size is 12.5' x 8.5' x 9' tall. 4. There will be access doors as indicated in the sketch, in addition to a high-powered exhaust fan for cross ventilation. Intake louvers will be included in one panel for outside source, low velocity intake air. 5. UBI will shorten the PRV exhaust to free up aisle space. 6. Lastly, the enclosure is expected to reduce noise from the present 93 dBA at 3 feet average, to under 80 dBA. The enclosure will be shipped in one piece on a flatbed and requires a crane to be lifted off, estimated weight is 2,600lbs. Price includes engineering, submittal, field verification, delivery, installation, and testing. 7. Wire up fan and startup unit.	1	23,880.21	23,880.21

Lengthening of the concrete pad to accept the overhang is excluded from this proposal. UBI will provide blocks at each of the two open corners to support the weight.

**TOTAL**

**\$23,880.21**

Accepted By

Accepted Date

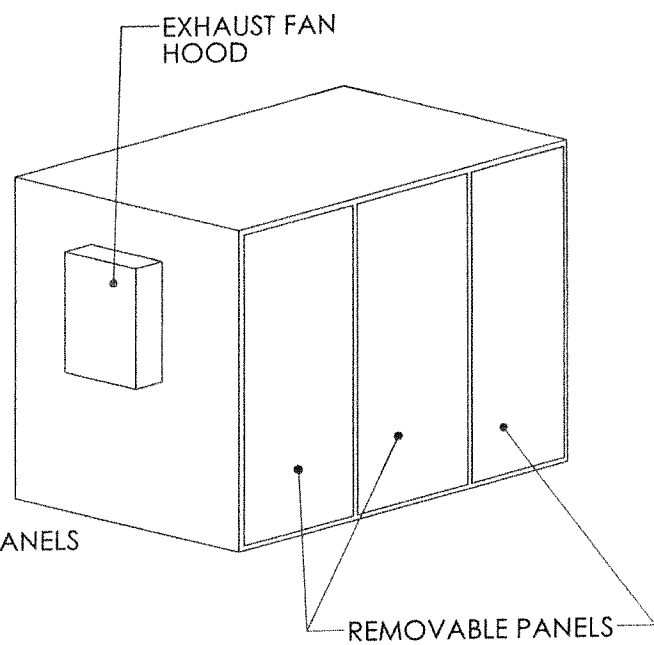
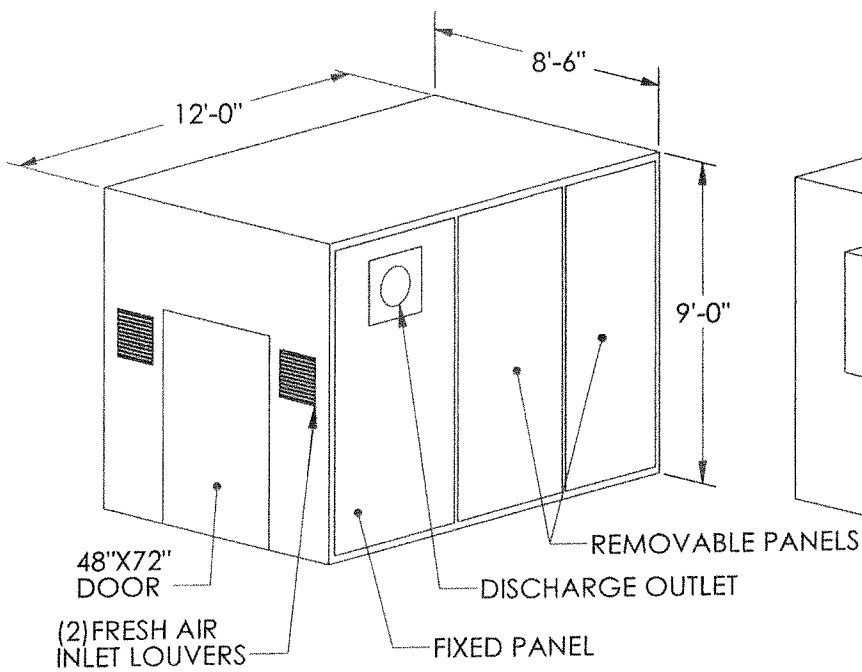

- Note:
1. 2" Acoustical Foam Packed Panels
  2. Powdercoated Light Grey

<b>UP</b>	<b>UNITED BLOWER INC.</b>	1198 AIRPORT DR BALLGROUND, GA 30107 T: 770-479-3000 F: 770-479-3111
	<b>Loganville Blower Enclosure</b>	
SIZE <b>A</b>	DWG. NO.	REV.
SCALE: 1:48	DR BY: WILLIAM CORTES-VEGA	DATE: 8-18-2011



## 2" ACOUSTICAL FOAM INSULATED NOISE ENCLOSURE

### PART I - GENERAL

The acoustical enclosure shall be as manufactured by United Blower, Inc.

The acoustical enclosure shall be compatible with the rotary positive displacement blower furnished in this specification section and shall comprise a complete system.

Enclosure shall be constructed to easily accommodate service and maintenance functions without dismantling of the enclosure. The enclosure shall have a removable left and right side wall panels, plus a full size hinged front panel appropriately placed for viewing and maintenance purposes.

Enclosure shall include a removable roof panel, which will permit removal of blower and/or the motor without removal of the enclosure.

The enclosure is suitable for outdoor installation and designed for a small load limit of 25 lbs/ft<sup>2</sup>.

Enclosure ventilation inlet shall be mounted directly in line with motor fan such as to allow ventilation for motor cooling.

The enclosure shall be appropriately sealed and be suitable for outside service in temperatures between -40°F to 120°F.

The enclosure as a whole shall be designed to accept up to 50 mph winds without the need for additional bracing.

Optional bracing shall be available to secure against 70 mph wind loads.

### PART II - MATERIALS AND CONSTRUCTION

The acoustical enclosure shall be as manufactured by United Blower, Inc.

1. All panels shall be constructed as follows:

a. Material: Galvanized steel G-90

b. Outer skin: 18 GA Minimum

c. Acoustical insulation: Each panel assembly shall be completely filled with 2" acoustical insulation.



2. Acoustical insulation shall have the following properties:
  - a. Density (Per ASTM D3574-86 Test A): 4 lb./ft<sup>3</sup>
  - b. Thermal Conductivity (per ASTM C177): 2 BTU/hr.
  - c. Tensile Strength (Per ASTM D3574-86 Test E): 20 psig
  - d. Heat Resistance (Per ASTM D3574-86 Test K): 70% after 22 hours dry heat @ 284°F
  - e. Humidity Resistance (Per ASTM D3574-86 Test J): 70% after 6 hours steam @ 221°F
  - f. Service Temperature: -40°F to 275°F (325°F intermittent)
  - g. Flammability: MVSS 302, UL-94 HF1, and FAR 25.853 (b)
  - h. Chemical resistance: Excellent for water, petroleum, solvents and alkalis
  
3. Each removable panel shall have two lifting handles to ease removal and a minimum of four lift and turn fasteners to secure the removable panels in the frame.
  - a. Fasteners: Fasteners shall be Zinc plated (Zinc is compatible with aluminum, galvanized and carbon steel).
  - b. Frame: The frame rails shall be made of 2" square extruded aluminum with (2) 1" lips to be utilized as panel shoulders. The rails shall be connected together to create the outer shape of the enclosure with the use of cast aluminum end connectors. The end connectors shall have three protrusions that slide into each adjoining frame rail. Each protrusion shall have a polyurethane strip on one side to ensure a tight fit with the adjoining frame rail. The frame rails shall be secured in place to the end connectors with two TEC screws.
  - c. Weather Hoods: The inlet ventilation openings shall be covered with an acoustical foam insulated weather hood. The outer skin of the weather hood shall be made from the same material as the panel walls. In addition, the inner surface shall be lined with acoustical foam in the same manner as stated in Part II, section I, part d.

### PART III - PERFORMANCE

Noise levels measured at three feet from the enclosure with one blower in operation shall be reduced 14-18 dBA (on average when compared to same blower package without noise enclosure) when measured on the "A" scale of a standard sound level meter at low response. Where noise levels are determined by octave band analysis, the equivalent A-weighted sound levels shall be computed as set forth in 29 CFR 1910.95 (a).

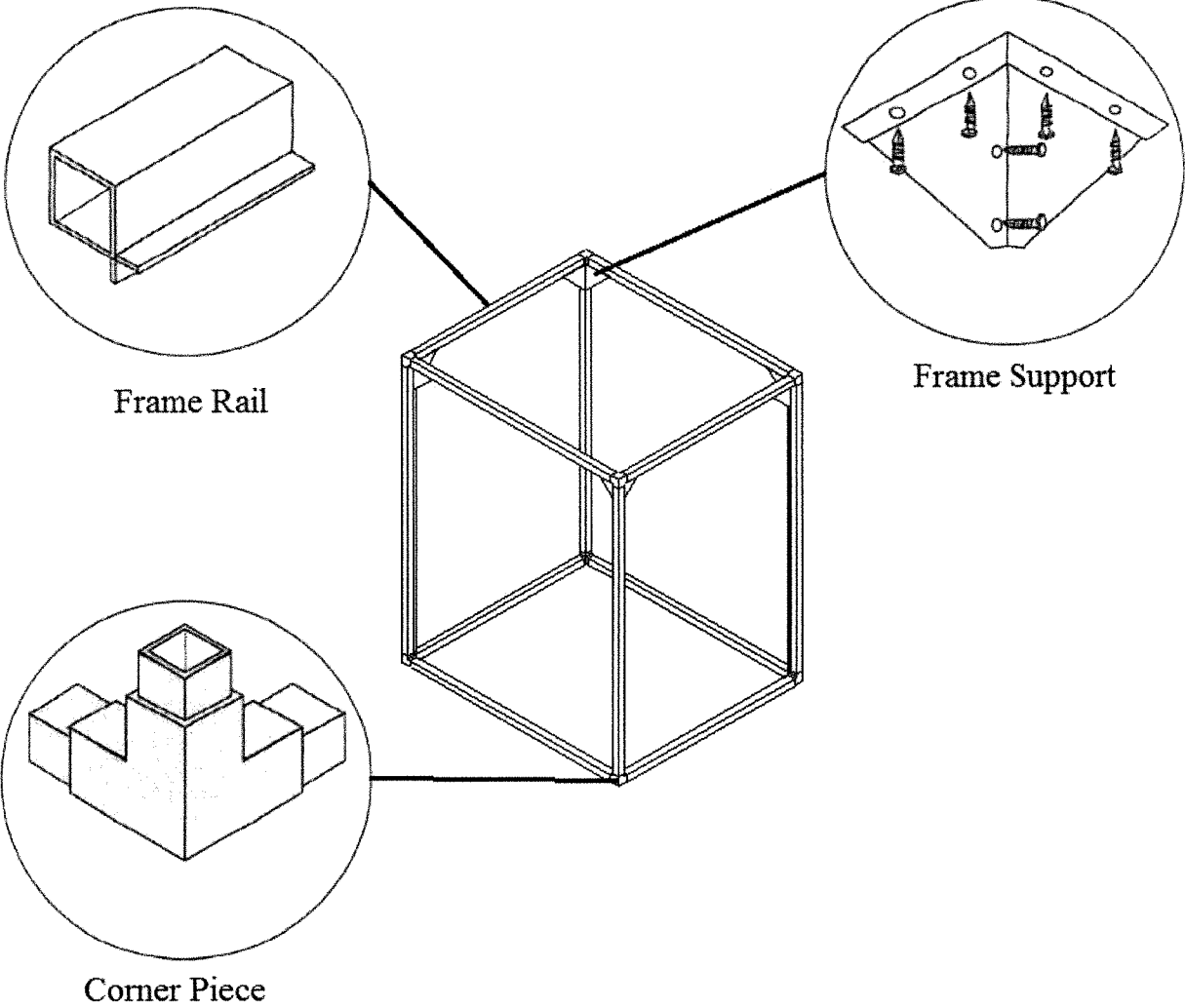

### **LIST OF MATERIALS**

1. Frame Rail: 2" x 2" x 14 GA Extruded Aluminum
2. Frame Support: 14 GA Aluminum (3003-H14)
3. 4 Corner Pieces: Black ABS Plastic

# Noise Enclosure Panel Detail

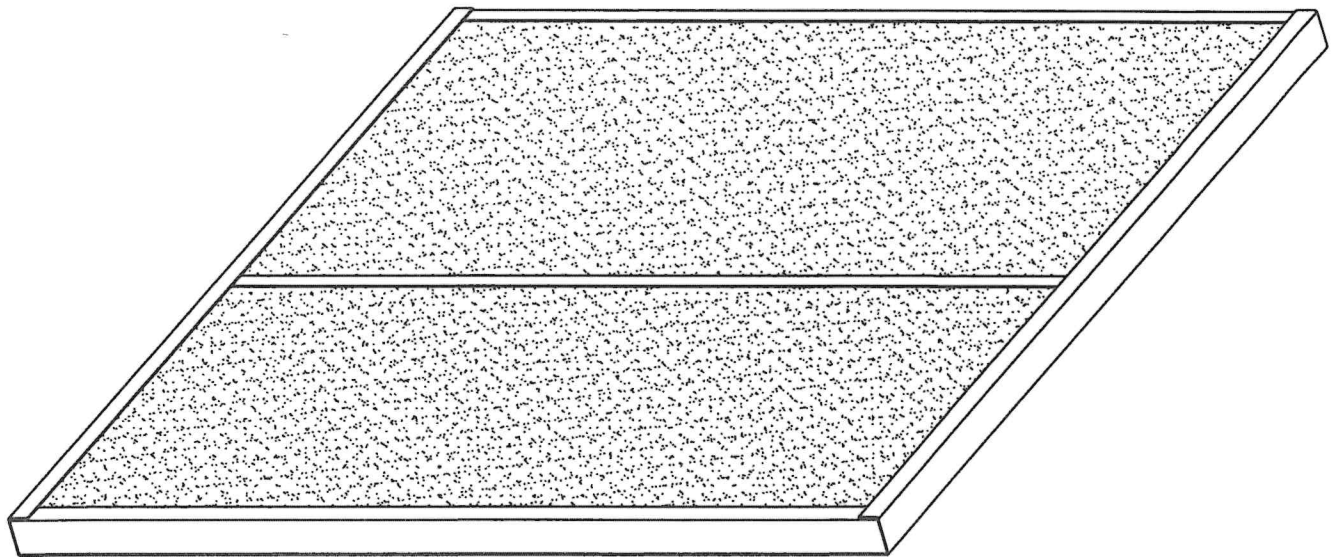
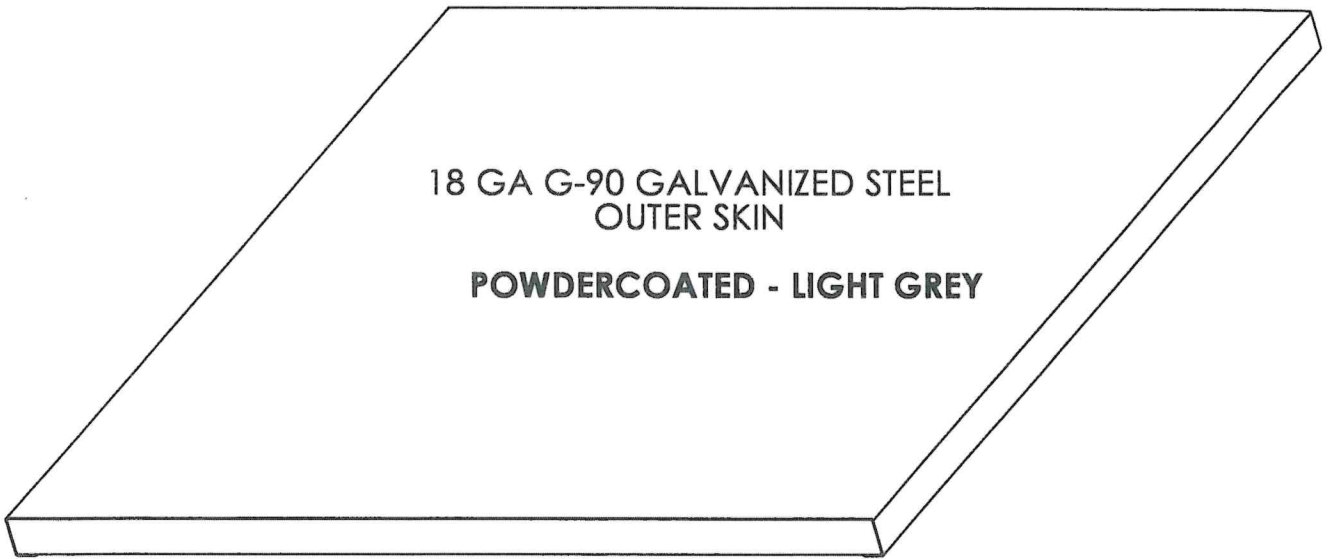

2" Acoustical Foam Insulation

Note:

1. 2" Thick Panels
2. See submittal for dimensions

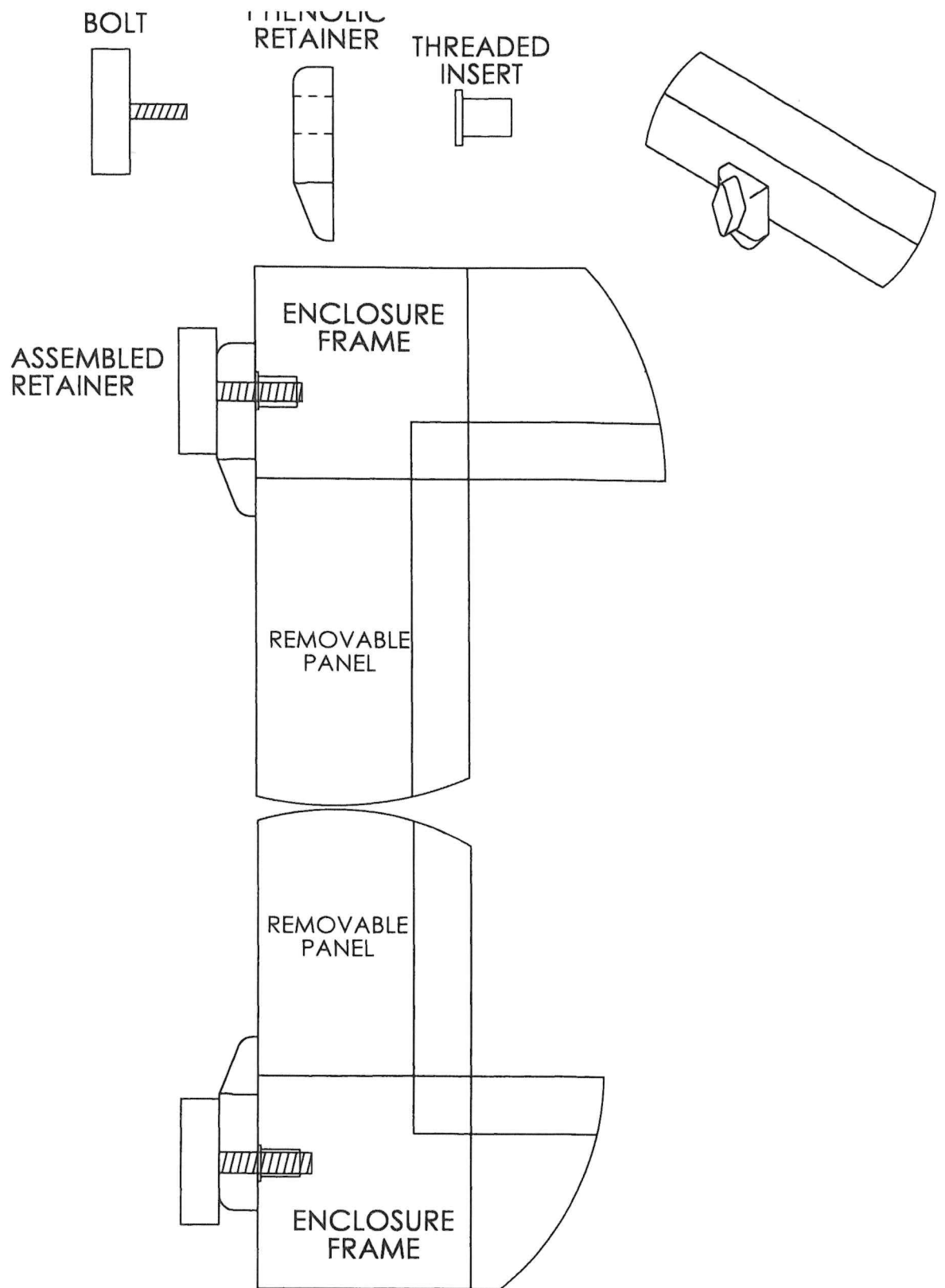

NOTE:  
 PANEL RETAINERS LOCK USING A THUMB BOLT.  
 THE THUMB BOLT SCREWS OUT THE THREADED INSERT  
 IN THE ENCLOSURE FRAME REMOVING THE PHENOLIC RETAINER



## GAF 12" HIGH VOLUME DIRECT DRIVE EXHAUST FAN

- Totally enclosed, 115V, 60 Hz, single phase motor  
1600 cfm  
1/5 HP  
1.65 Full Load Amps (FLA)  
Class A Insulation  
Bearing: Sleeve Type  
140°F maximum ambient temperature
- Air delivery based on AMCA test codes
- Built-in 60° to 120°F thermostat housed in steel conduit box
- Three blade deep pitch galvanized steel fan
- Vertical or horizontal mounting
- 13" diameter x 8.25" deep galvanized steel outer shroud, 15" square mounting frame with #13-1/2" expanded metal fan guard (OSHA)
- Motor is designed for continuous or intermittent operation
- GAF Part No.: EGV6
- Shipping Weight: 11 lbs.
- Wire Size: 18 Gauge
- Built-in motor overtemp protection

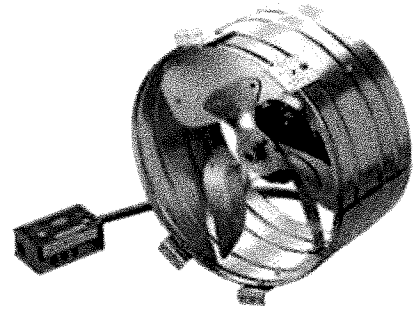

# N.E. Exhaust Fan Thermostat (Set @ 90°F)

This line voltage thermostat P/N PT6 utilizes a sensitive bi-metal operated snap action switch which provides control for resistive or inductive loads. By turning the dial to the lowest setting, it will effectively turn off the fan. Setting the dial between the high and low set points allows the unit to operate automatically. Turning the dial to the highest set point will allow the fan to run continuously, rendering this as an H-O-A switch.

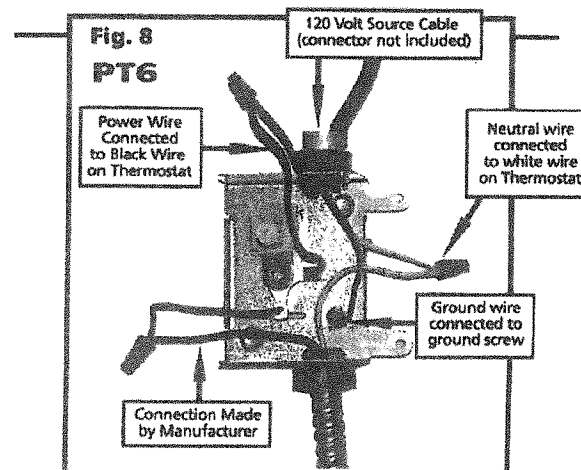
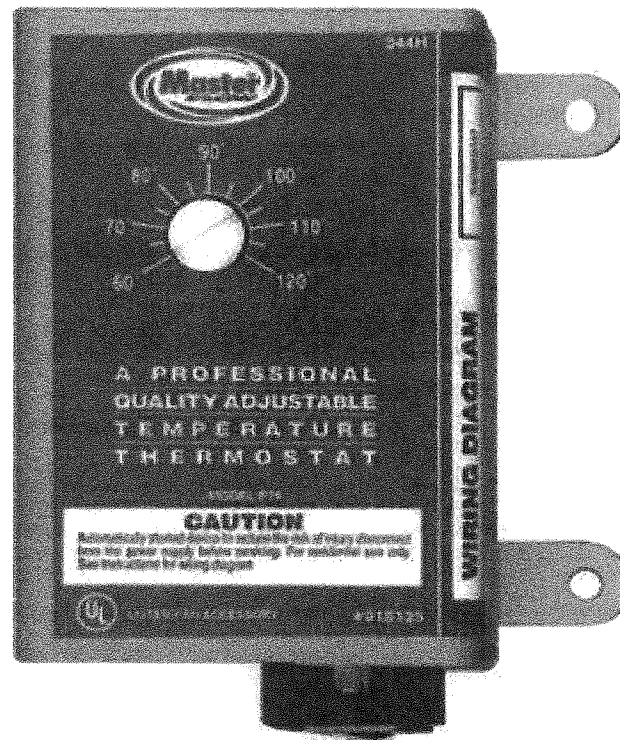

## **SPECIFICATIONS**

Switch Action: Snap action single pole (N.O.-SPDT).

Amps @ 120V: 6

Temp. Setting Range: 60F-120F

Maximum ambient Temp: 170F

Approval: UL Listed

Galvanized Steel Enclosure



1198 AIRPORT DR  
BALLGROUND, GA 30107  
T: 770-479-3000  
F: 770-479-3111

## N.E. Thermostat