

H:\15158001\15860\21 2021 Road Bord Paving Project\Drawing Files\Engineering\Lathrup Base 2021.dwg

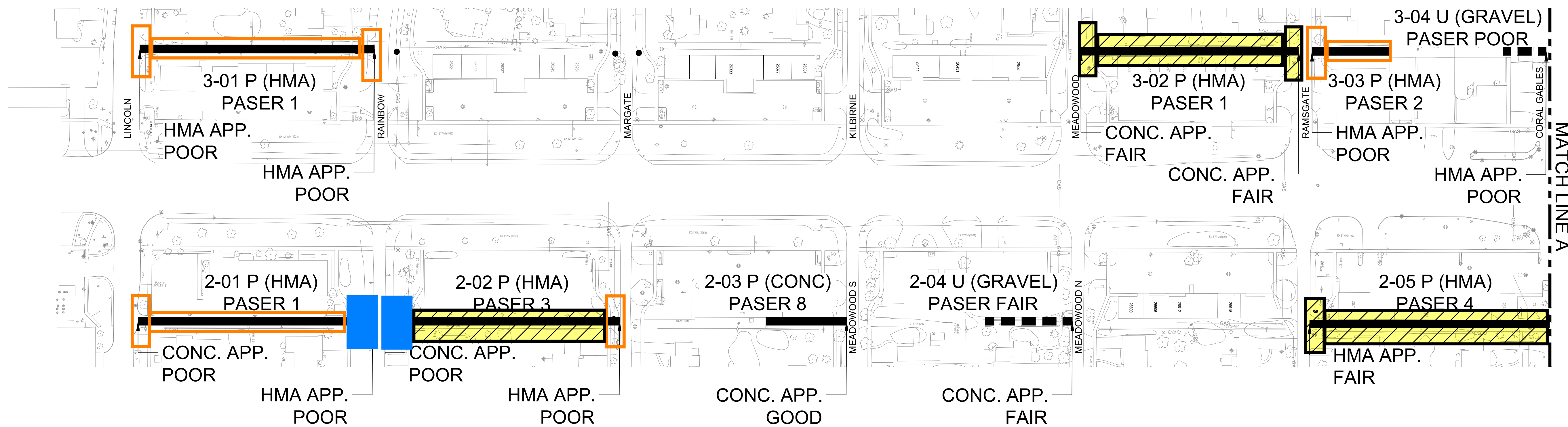

KEY: X-XX P/U
 ↑ PAVED OR UNIMPROVED
 ↑ ALLEY NUMBER
 1 = NORTH OF 11 MILE AND EAST OF SOUTHFIELD
 2 = SOUTH OF 11 MILE AND EAST OF SOUTHFIELD
 3 = SOUTH OF 11 MILE AND WEST OF SOUTHFIELD
 4 = NORTH OF 11 MILE AND WEST OF SOUTHFIELD

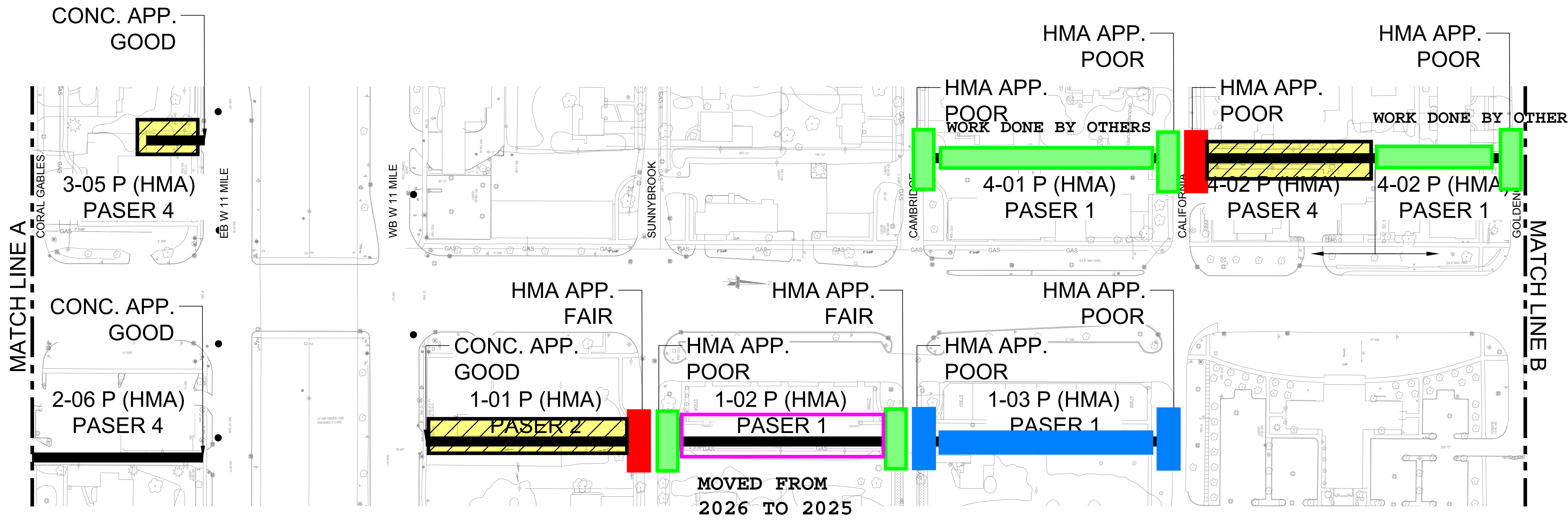
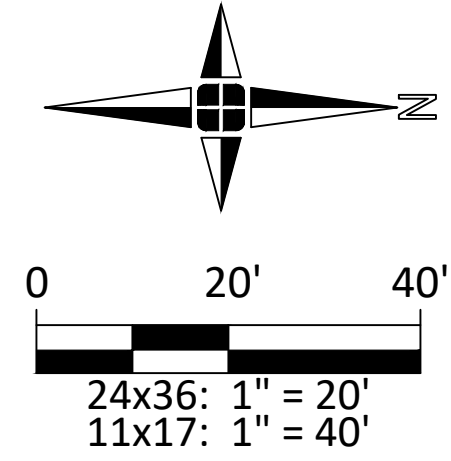

- 2021 (COMPLETED)
- 2022 (COMPLETED)
- 2023 (COMPLETED)
- 2024
- 2025
- NOT YET SCHEDULED

PROPOSED 5-YR CIP



Engineers
 Surveyors
 Planners
 Landscape Architects

1025 East Maple Road
 Suite 100
 Birmingham, MI 48009
 p (248) 852-3100
 f (313) 962-5068
 www.giffelswebster.com

| | |
|------------------|--------|
| Executive: | S.A.R. |
| Manager: | S.A.R. |
| Designer: | A.J.K. |
| Quality Control: | S.A.R. |



Know what's below.
 Call before you dig.

| DATE: | ISSUE: |
|-------|--------|
| | |
| | |
| | |
| | |

Developed For:
 CITY OF LATHRUP VILLAGE
 27400 SOUTHFIELD ROAD
 LATHRUP VILLAGE, MI 48076
 (248) 557-2600

ALLEY ASSESSEMENT (1 OF 2)

CITY OF LATHRUP VILLAGE
 OAKLAND COUNTY
 MICHIGAN

| | |
|----------|----------|
| Date: | 5.18.21 |
| Scale: | AS SHOWN |
| Sheet: | 1 of 2 |
| Project: | 18736.21 |

Copyright © 2021 Giffels Webster.
 No reproduction shall be made without the prior written consent of Giffels Webster.

H:\1515800\15860\21 2021 Road Bord Paving Project\Drawing Files\Engineering\Lathrup Base 2021.dwg

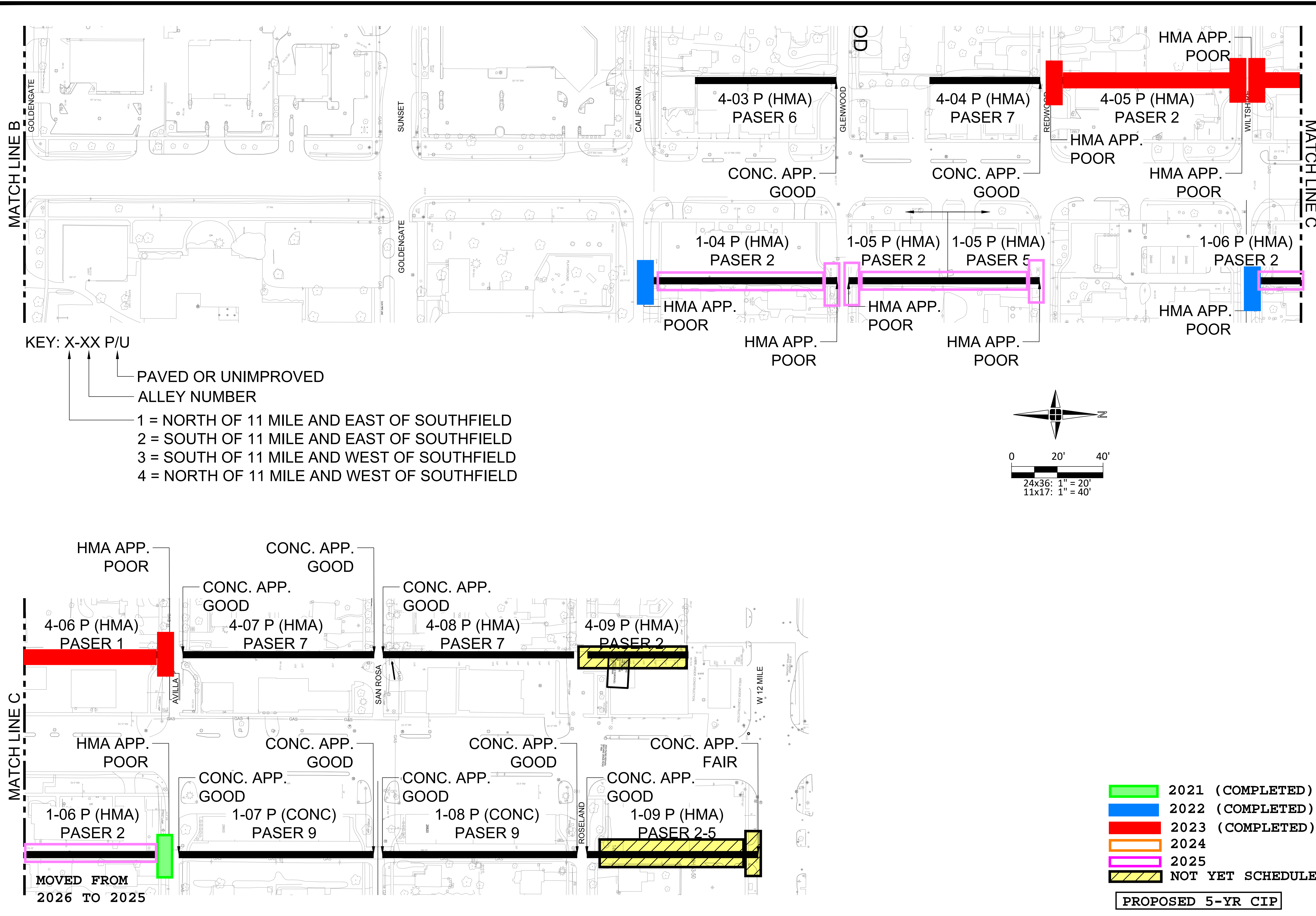

KEY: X-XX P/U

PAVED OR UNIMPROVED
ALLEY NUMBER

- 1 = NORTH OF 11 MILE AND EAST OF SOUTHFIELD
- 2 = SOUTH OF 11 MILE AND EAST OF SOUTHFIELD
- 3 = SOUTH OF 11 MILE AND WEST OF SOUTHFIELD
- 4 = NORTH OF 11 MILE AND WEST OF SOUTHFIELD

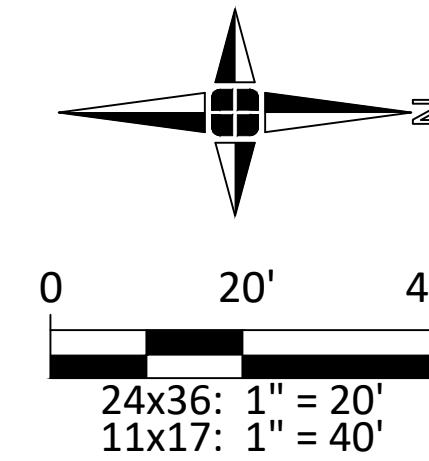

giffels webster

Engineers
Surveyors
Planners
Landscape Architects

1025 East Maple Road
Suite 100
Birmingham, MI 48009
p (248) 852-3100
f (313) 962-5068
www.giffelswebster.com

Executive: S.A.R.
Manager: S.A.R.
Designer: A.J.K.
Quality Control: S.A.R.



Know what's below.
Call before you dig.

| DATE: | ISSUE: |
|-------|--------|
| | |
| | |
| | |
| | |
| | |

Developed For:
CITY OF LATHRUP VILLAGE
27400 SOUTHFIELD ROAD
LATHRUP VILLAGE, MI 48076
(248) 557-2600

ALLEY ASSESSMENT (2 OF 2)

CITY OF LATHRUP VILLAGE
OAKLAND COUNTY
MICHIGAN

Date: 5.18.21
Scale: AS SHOWN
Sheet: 2 of 2
Project: 18736.21

Copyright © 2021 Giffels Webster.
No reproduction shall be made without the prior written consent of Giffels Webster.

- █ 2021 (COMPLETED)
- █ 2022 (COMPLETED)
- █ 2023 (COMPLETED)
- █ 2024
- █ 2025
- NOT YET SCHEDULED

PROPOSED 5-YR CIP