

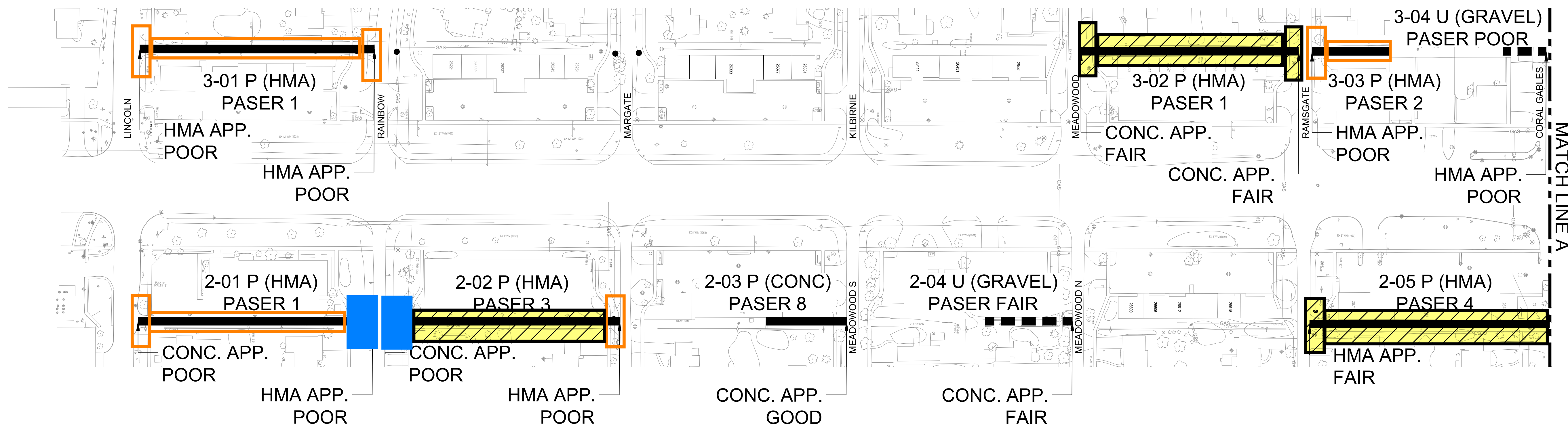

H:\1515800\15860\21 2021 Road Bord Paving Project\Drawing Files\Engineering\Lathrup Base 2021.dwg



KEY: X-XX P/U

PAVED OR UNIMPROVED  
ALLEY NUMBER

- 1 = NORTH OF 11 MILE AND EAST OF SOUTHFIELD
- 2 = SOUTH OF 11 MILE AND EAST OF SOUTHFIELD
- 3 = SOUTH OF 11 MILE AND WEST OF SOUTHFIELD
- 4 = NORTH OF 11 MILE AND WEST OF SOUTHFIELD

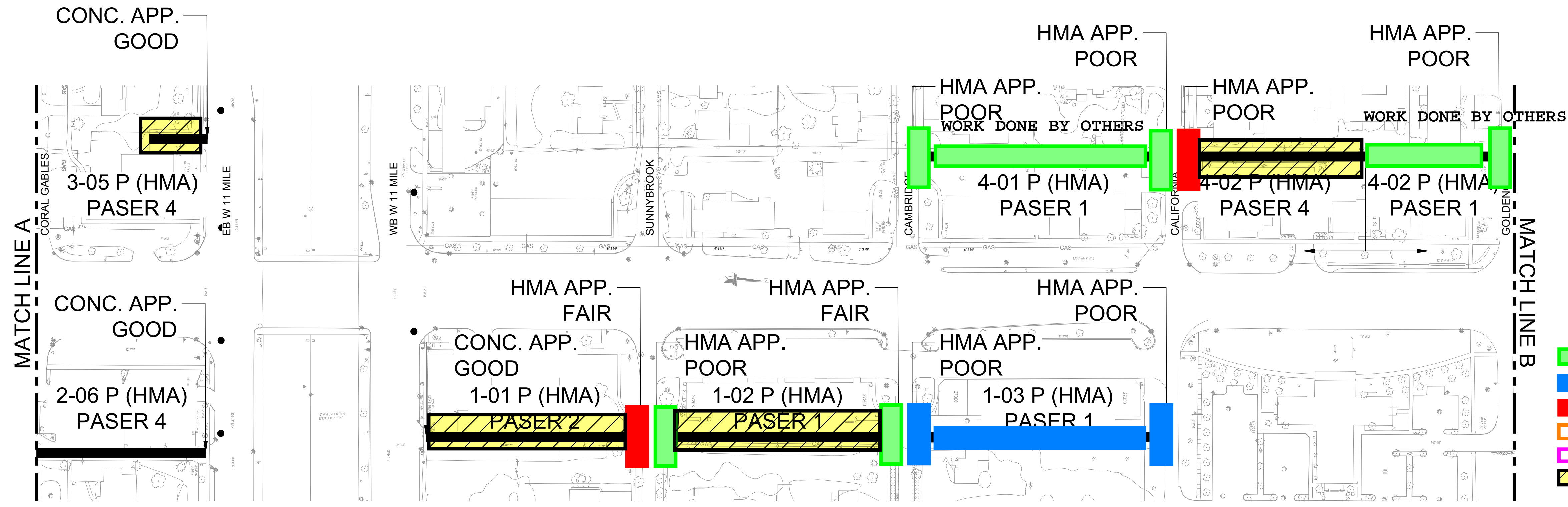
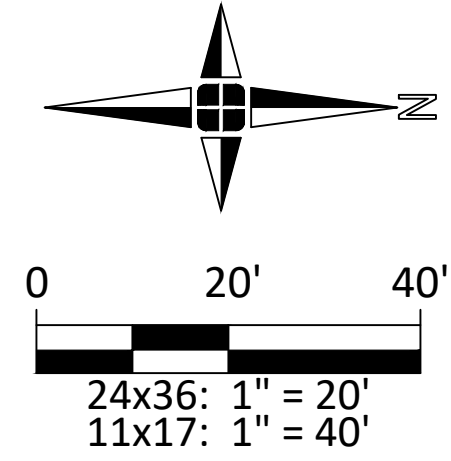

- █ 2021 (COMPLETED)
- █ 2022 (COMPLETED)
- █ 2023 (COMPLETED)
- █ 2024
- █ 2025
- █ NOT YET SCHEDULED

**PROPOSED 5-YR CIP**



Engineers  
Surveyors  
Planners  
Landscape Architects

1025 East Maple Road  
Suite 100  
Birmingham, MI 48009  
p (248) 852-3100  
f (313) 962-5068  
www.giffelswebster.com

Executive:	S.A.R.
Manager:	S.A.R.
Designer:	A.J.K.
Quality Control:	S.A.R.



Know what's below.  
Call before you dig.

DATE:	ISSUE:

Developed For:  
**CITY OF LATHRUP VILLAGE**  
27400 SOUTHFIELD ROAD  
LATHRUP VILLAGE, MI 48076  
(248) 557-2600

## ALLEY ASSESSEMENT (1 OF 2)

CITY OF LATHRUP VILLAGE  
OAKLAND COUNTY  
MICHIGAN

Date:	5.18.21
Scale:	AS SHOWN
Sheet:	1 of 2
Project:	18736.21

Copyright © 2021 Giffels Webster.  
No reproduction shall be made without the prior written consent of Giffels Webster.

H:\1515800\15860\21 2021 Road Bond Paving Project\Drawing Files\Engineering\Lathrup Base 2021.dwg

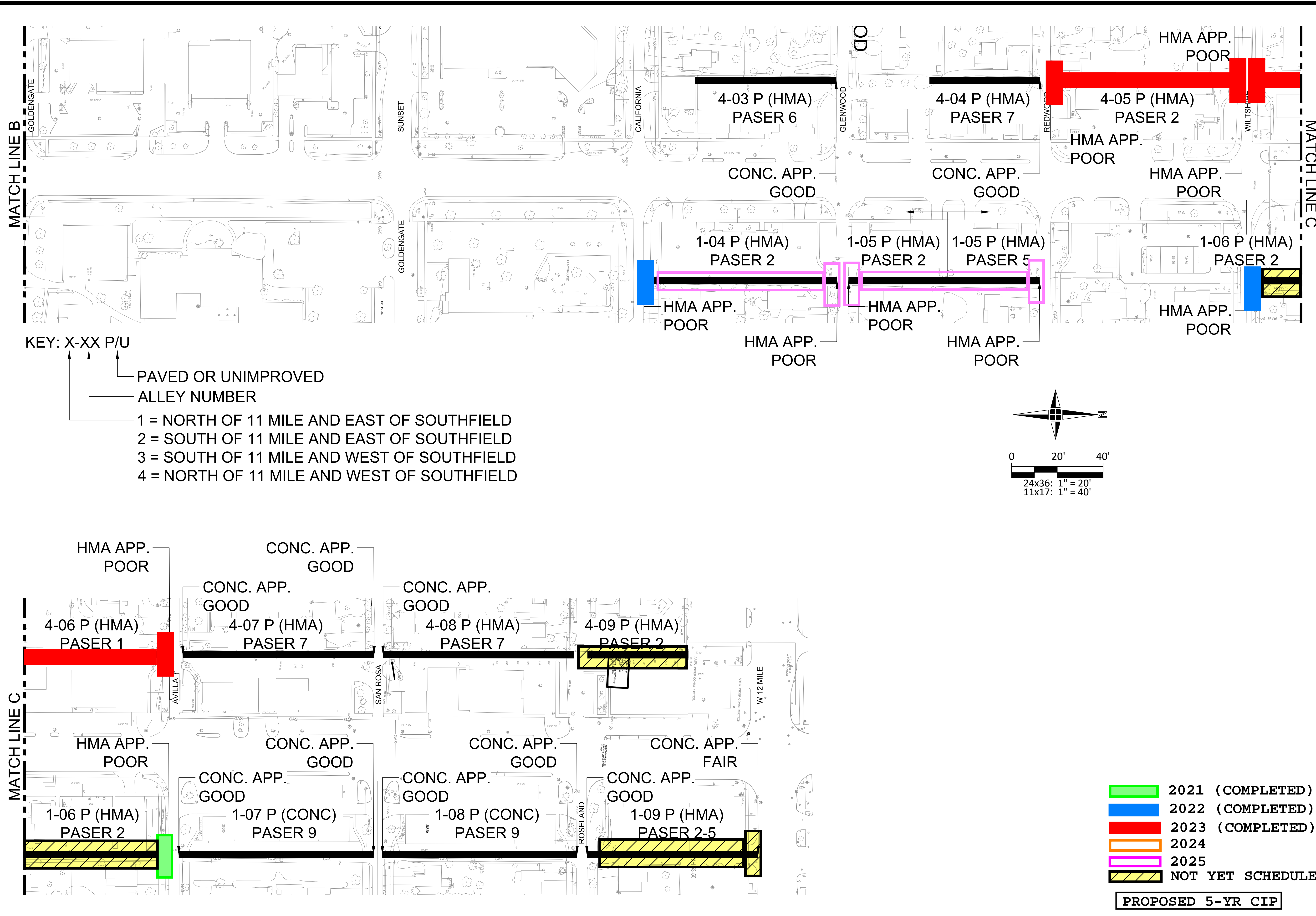

KEY: X-XX P/U

PAVED OR UNIMPROVED ALLEY NUMBER

- 1 = NORTH OF 11 MILE AND EAST OF SOUTHFIELD
- 2 = SOUTH OF 11 MILE AND EAST OF SOUTHFIELD
- 3 = SOUTH OF 11 MILE AND WEST OF SOUTHFIELD
- 4 = NORTH OF 11 MILE AND WEST OF SOUTHFIELD

- 2021 (COMPLETED)
- 2022 (COMPLETED)
- 2023 (COMPLETED)
- 2024
- 2025
- NOT YET SCHEDULED

PROPOSED 5-YR CIP



Engineers  
Surveyors  
Planners  
Landscape Architects

1025 East Maple Road  
Suite 100  
Birmingham, MI 48009  
p (248) 852-3100  
f (313) 962-5068  
www.giffelswebster.com

Executive: S.A.R.  
Manager: S.A.R.  
Designer: A.J.K.  
Quality Control: S.A.R.



Know what's below.  
Call before you dig.

DATE:	ISSUE:

Developed For:  
**CITY OF LATHRUP VILLAGE**  
27400 SOUTHFIELD ROAD  
LATHRUP VILLAGE, MI 48076  
(248) 557-2600

**ALLEY ASSESSMENT (2 OF 2)**

CITY OF LATHRUP VILLAGE  
OAKLAND COUNTY  
MICHIGAN

Date: 5.18.21  
Scale: AS SHOWN  
Sheet: 2 of 2  
Project: 18736.21

Copyright © 2021 Giffels Webster.  
No reproduction shall be made without the prior written consent of Giffels Webster.